

Use and Disclosure of Data

Information contained herein is classified as EAR99 under the  
U.S. Export Administration Regulations.  
Export, reexport or diversion contrary to U.S. law is prohibited.

Teledyne Analytical Instruments

**3220**

Oxygen Monitor System

P/N: M73831  
ECO# 07-0026  
08/17/07



## Instruction Manual

# Model 3220

### Multi-Channel Oxygen Monitor



#### **DANGER**



Toxic gases and or flammable liquids may be present in this monitoring system.

Personal protective equipment may be required when servicing this instrument.

Hazardous voltages exist on certain components internally which may persist for a time even after the power is turned off and disconnected.

Only authorized personnel should conduct maintenance and/or servicing. Before conducting any maintenance or servicing, consult with authorized supervisor/manager.



### Copyright © 2001 TELEDYNE Analytical Instruments

All Rights Reserved. No part of this manual may be reproduced, transmitted, transcribed, stored in a retrieval system, or translated into any other language or computer language in whole or in part, in any form or by any means, whether it be electronic, mechanical, magnetic, optical, manual, or otherwise, without the prior written consent of Teledyne Analytical Instruments, 16830 Chestnut Street, City of Industry, CA 91749-1580.

### Warranty

This equipment is sold subject to the mutual agreement that it is warranted by us free from defects of material and of construction, and that our liability shall be limited to replacing or repairing at our factory (without charge, except for transportation), or at customer plant at our option, any material or construction in which defects become apparent within one year from the date of shipment, except in cases where quotations or acknowledgments provide for a shorter period. Components manufactured by others bear the warranty of their manufacturer. This warranty does not cover defects caused by wear, accident, misuse, neglect or repairs other than those performed by Teledyne or an authorized service center. We assume no liability for direct or indirect damages of any kind and the purchaser by the acceptance of the equipment will assume all liability for any damage which may result from its use or misuse.

We reserve the right to employ any suitable material in the manufacture of our apparatus, and to make any alterations in the dimensions, shape or weight of any parts, in so far as such alterations do not adversely affect our warranty.

### Important Notice

This instrument provides measurement readings to its user, and serves as a tool by which valuable data can be gathered. The information provided by the instrument may assist the user in eliminating potential hazards caused by his process; however, it is essential that all personnel involved in the use of the instrument or its interface, with the process being measured, be properly trained in the process itself, as well as all instrumentation related to it.

The safety of personnel is ultimately the responsibility of those who control process conditions. While this instrument may be able to provide early warning of imminent danger, it has no control over process conditions, and it can be misused. In particular, any alarm or control systems installed must be tested and understood, both as to how they operate and as to how they can be defeated. Any safeguards required such as locks, labels, or redundancy, must be provided by the user or specifically requested of Teledyne at the time the order is placed.

Therefore, the purchaser must be aware of the hazardous process conditions. The purchaser is responsible for the training of personnel, for providing hazard warning methods and instrumentation per the appropriate standards, and for ensuring that hazard warning devices and instrumentation are maintained and operated properly.

Teledyne Analytical Instruments (TAI) cannot accept responsibility for conditions beyond its knowledge and control. No statement expressed or implied by this document or any information disseminated by the manufacturer or its agents, is to be construed as a warranty of adequate safety control under the user's process conditions.

## **Specific Model Information**

The Instrument for which this manual was supplied may incorporate one or more options not present in the standard instrument. If such options were specified at the time of purchase, an addendum describing the unique features and specifics of the included options will be included with this manual. Please check the frontmatter of this manual to see if an addendum has been included.

Instrument Serial Number: \_\_\_\_\_

## Important Notice

---

The Model 3220 is a safety monitor, however, it is the responsibility of the user to establish whether or not the total system of instrument, environment, alarm components, and any other relevant devices actually will assure safety under the particular circumstances of use.

Location of the equipment and sensors that will insure proper operation is the responsibility of the user.

The safety checklist outlined below is only a guide. It is up to the user to establish practical safety precautions given his/her own specific circumstances. *It is vital that the operator understand and test the operation of the total system.*

## Safety Checklist

- Verify that the instrument is powered correctly.
- Verify that the instrument works properly (all functions).
- Verify that alarm conditions produce the intended results.
- Verify that unauthorized personnel cannot tamper with the instrument or its auxiliary equipment.
- Institute routine test/calibration procedures.
- Identify and handle any potential problems in sampling or location.
- Train all operators to *understand all operations and functions of the analyzer and the system.*
- Identify and handle any environmental or other influences that could affect the operation of the instrument.

### Safety Messages

---

Your safety and the safety of others is very important. We have provided many important safety messages in this manual. Please read these messages carefully.

A safety message alerts you to potential hazards that could hurt you or others. Each safety message is associated with a safety alert symbol. These symbols are found in the manual and inside the instrument. The definition of these symbols is described below:



**GENERAL WARNING/CAUTION:** Refer to the instructions for details on the specific danger. These cautions warn of specific procedures which if not followed could cause bodily Injury and/or damage the instrument.



**CAUTION: HOT SURFACE WARNING:** This warning is specific to heated components within the instrument. Failure to heed the warning could result in serious burns to skin and underlying tissue.



**WARNING: ELECTRICAL SHOCK HAZARD:** Dangerous voltages appear within this instrument. This warning is specific to an electrical hazard existing at or nearby the component or procedure under discussion. Failure to heed this warning could result in injury and/or death from electrocution.



*Technician Symbol:* All operations marked with this symbol are to be performed by qualified maintenance personnel only.

*NOTE:* Additional information and comments regarding a specific component or procedure are highlighted in the form of a note.

**CAUTION:**



**THE ANALYZER SHOULD ONLY BE USED FOR THE PURPOSE AND IN THE MANNER DESCRIBED IN THIS MANUAL.**

**IF YOU USE THE ANALYZER IN A MANNER OTHER THAN THAT FOR WHICH IT WAS INTENDED, UNPREDICTABLE BEHAVIOR COULD RESULT POSSIBLY ACCOMPANIED WITH HAZARDOUS CONSEQUENCES.**



This manual provides information designed to guide you through the installation, calibration and operation of your new analyzer. Please read this manual and keep it available.

Occasionally, some instruments are customized for a particular application or features and/or options added per customer requests. Please check the front of this manual for any additional information in the form of an Addendum which discusses specific information, procedures, cautions and warnings that may be peculiar to your instrument.

Manuals do get lost. Additional manuals can be obtained from Teledyne at the address given in the Appendix. Some of our manuals are available in electronic form via the internet. Please visit our website at: [www.teledyne-ai.com](http://www.teledyne-ai.com).

## Table of Contents

---

<b>Important Notice</b> .....	<b>vi</b>
Safety Checklist .....	vi
<b>Safety Messages</b> .....	<b>vii</b>
<b>Table of Contents</b> .....	<b>ix</b>
<b>List of Figures</b> .....	<b>xii</b>
<b>List of Tables</b> .....	<b>xiii</b>
<b>Introduction</b> .....	<b>1</b>
1.1 Overview .....	1
1.2 Description .....	1
1.2.1 System Chassis (19" Rack) .....	2
1.2.2 Control Unit .....	2
1.2.3 Channel Modules .....	2
1.2.3.1 Main Features of the Channel Module .....	2
1.2.4 Remote Probe Assemblies .....	4
<b>Operational Theory</b> .....	<b>6</b>
2.1 Introduction .....	6
2.2 System Chassis .....	6
2.3 Control Unit .....	6
2.4 Channel Module .....	8
2.5 Micro-fuel Cell .....	10
2.5.1 Anatomy of a Micro-Fuel Cell .....	10
2.5.2 Electrochemical Reactions .....	12
2.5.3 The Effect of Pressure .....	12
2.5.4 Calibration Characteristics .....	13
2.5.4 Micro-Fuel Cell "Class" .....	14
2.5.4.1 Class A-3 Cell .....	14
2.5.4.2 Class A-5 Cell .....	14
2.5.4.3 Class B-1 Cell .....	14

2.5.4.4 Class B-3 Cell	14
2.5.4.5 Class C-3 Cell	15
2.5.4.6 Hydrogen and/or Helium Service	15
<b>Installation.....</b>	<b>16</b>
3.1 Unpacking the Analyzer	16
3.2 System Chassis	16
3.2.1 Location	16
3.2.2 Power	16
3.3 Electrical Connections	17
3.4 Probe Assemblies	17
3.5 Micro-Fuel Cell	18
3.6 Control Unit	19
3.6.1 Control Unit Fuses	19
3.6.2 Control Unit Jumper Settings	20
3.7 Channel Modules	22
3.7.1 Removing the Channel Module Cover	22
3.7.2 Changing the Fuse	22
3.7.3 Configuring the Internal Jumper Connections	23
<b>Operation.....</b>	<b>25</b>
4.1 Introduction	25
4.2 Control Unit Operation	25
4.2.1 System Power Switch and LED	25
4.2.2 Audible Alarm Switch and Bypass LED	25
4.2.3 Fuses	26
4.2.4 RS485 Port	26
4.3 Channel Module Front Panel Controls and Indicators	26
4.4 Calibration Procedures	30
4.4.1 Zero Calibrating a Single Sensor Channel Module	30
4.4.2 Span Calibrating a Channel Module	31
4.4.5 Using the “1MAN” Calibration Option	31
4.4.5.1 Zero and Span Calibrating a Channel Module	31
4.5 Alarm Configuration Procedures	32
4.5.1 Defining the Setpoint for Alarm 1 and Alarm 2	32

## Oxygen Monitor System

---

4.5.2	Configuring Alarm Relay Settings	33
4.5.2.1	Setting the Fail-safe or Non-Fail-safe Mode	33
4.5.2.2	Setting the Latching or Non-Latching Mode	33
4.5.2.3	Setting Alarms to Hi or Lo	34
4.6	Setting the ID Code	34
4.7	Enabling/Disabling the Pass Code	35
4.8	Range Set-Up	36
4.9	Cell Failure Set-Up	37
4.10	Routine Operation	38
4.11	FAIL Alarm Conditions	37
	<b>Failure and Error Codes.....</b>	<b>38</b>
5.1	Failure Codes	38
5.2	Error Codes	38
	<b>Appendix.....</b>	<b>40</b>
A-1	Specifications	40
	Recommended Spare Parts List	41
	Drawing List	42
	Index	45

## List of Figures

---

Figure 1-1: Model 3220 System .....	1
Figure 1-2: Control Unit.....	2
Figure 1-3: The Channel Module .....	3
Figure 2-1: Control Unit Front Panel .....	7
Figure 2-2: Control Unit Block Diagram .....	7
Figure 2-3: Block Diagram of the Signal Processing Electronics ....	9
Figure 2-4: Micro-fuel Cell.....	10
Figure 2-5: Cross Section of a Micro-fuel Cell.....	11
Figure 2-6: Characteristic Input/Output Curve for MFC.....	13
Figure 3-1: Oxygen Probe Assembly .....	18
Figure 3-2: Fuse Location .....	23
Figure 4-1: RS-485 Port on Control Unit .....	26
Figure 4-2: Display Panel Configuration .....	29

### List of Tables

---

Table 3-1: Control Unit Jumper Configuration .....	20
Table 3-2: Fail-safe/Non Fail-safe Alarm Configuration.....	20
Table 3-3: External Alarm—Failsafe/Non-failsafe Configuration ...	21
Table 3-4: External Alarm—Contact Closure.....	21
Table 3-5: External Alarm—Line Voltage to External Connection .	21
Table 3-6: Channel Module Internal Jumper Settings .....	23
Table 3-7: RS-485 Jumper Settings .....	24
Table 3-8: Jumper Settings for Channel Module Output .....	24



## Introduction

---

### 1.1 Overview

The Teledyne Analytical Instruments (TAI) Model 3220 Oxygen Monitor System is a multi-channel system that can be used for determining the concentration of oxygen gas in an atmosphere at a number of remote locations. The system provides alarm information when the oxygen concentration exceeds user definable limits at any one or all of the remote locations.

The oxygen gas content of the atmosphere is determined by a number of remotely located sensors that may be strategically placed to monitor the atmosphere surrounding their location.

The system is designed to provide indications of the state of each sensor and to actuate individual external alarm indicators as well as alarms common to all channels. The alarms are user-configurable.

### 1.2 Description

The 3220 system is comprised of a System Chassis, Control Unit, Channel Modules, and Remote Probe Assemblies. Each System Chassis contains one Control Unit and up to eight Channel Modules.

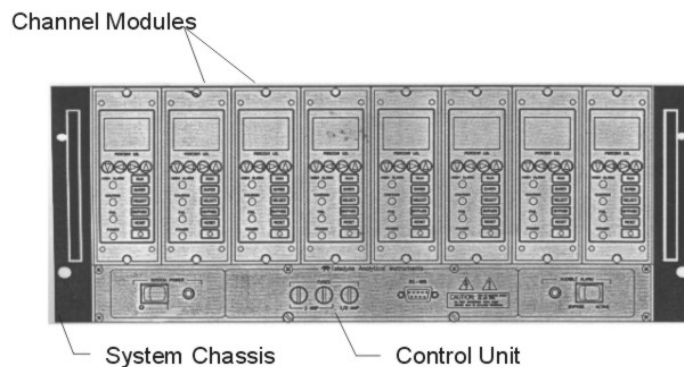

Figure 1-1: Model 3220 System



### 1.2.1 System Chassis (19" Rack)

The System Chassis provides structural support and electrical interconnection for the Control Unit and Channel Modules (up to eight Channel Modules may be installed). The Channel Modules plug into the sockets built into the System Chassis. Terminal strips at the rear of the System Chassis provide for external electrical connections.

### 1.2.2 Control Unit

The Control Unit handles power distribution to the entire system. The main power is controlled by a switch on the front panel and the system fuses are accessible from the front. The Control Unit also contains common alarm relays which indicate alarm conditions whenever any of the Channel Modules alarm. The Control Unit is shown in Figure 1-2.

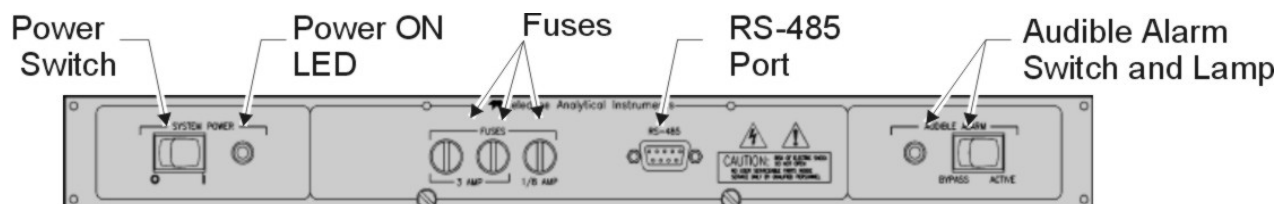

Figure 1-2: Control Unit

### 1.2.3 Channel Modules

Each Channel Module is a complete, self-contained instrument including integral power supply and requires only external AC power which it receives from the System Chassis socket. A channel is operational when plugged into the System Chassis.

Because a Channel Module plugs into the Control Unit, channels can easily be added to any control module with less than eight Channel Modules even after installation to monitor additional locations. Channel Modules in the same System Chassis may still be configured independently. A Channel Module is shown in Figure 1-3.

#### 1.2.3.1 MAIN FEATURES OF THE CHANNEL MODULE

The main features of the Channel Module include:

- High resolution LCD display readout
- Drop-in replacement for Model 322 instruments

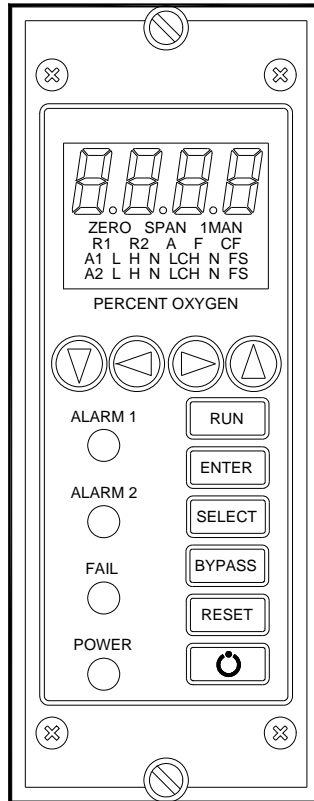

Figure 1-3: The Channel Module

- 1MAN calibration capability
- Membrane switch control
- Microprocessor based electronics
- Two concentration alarms with adjustable set-points
- System failure alarm
- User-friendly touch key controls
- Passcode protection
- Failure codes and testpoints
- Two selectable analog outputs (0-10V DC or negative ground 4-20 mA DC)
- Compact and versatile design: small footprint with accessible internal PCBs

#### **1.2.4 Remote Probe Assemblies**

Each Control Unit allows for up to eight remote probe assemblies. These assemblies can be of standard configuration (see Probe Assembly Outline Drawing in the drawing section of the Appendix) or special design (if equipped, unique features are described in an included addendum to this manual) depending on the application requirement. In either case, the probes can be located almost any distance (up to 1000 ft or more!) from the System Chassis.

Each probe assembly, when placed into service, will contain a Micro-fuel Cell, a temperature compensating thermistor and auxiliary sample handling equipment (if required). The Micro-fuel Cell is packaged in a gas barrier bag and should not be installed in the probe assembly until after installation of all other components of the system has been accomplished.

Temperature compensation is affected over the range 0-50°C and to an accuracy of  $\pm 5\%$  of full scale. If other than diffusion sampling is to be employed, it is assumed that the sample gas will be brought to ambient temperature. The cell and thermistor must always be kept at the same temperature, otherwise the resultant differential temperature of these two components can cause inaccuracies in excess of those specified.

If the ambient temperature at the probe assembly can drop below 0°C (32°F), auxiliary heating should be employed. Normally this condition is noted at the time of purchase and specially configured probes will have been provided. TAI can provide sampling probes to cope with most all

sampling problems encountered in virtually any application. Please refer to any included addenda for additional information regarding custom probes.

## Operational Theory

---

### 2.1 Introduction

The Model 3220 combustible gas analyzer is composed of four components:

1. System Chassis
2. Control Unit
3. Channel Modules
4. Micro-fuel Cell

The System Chassis provides structural support and electrical interconnection for a Control Unit and up to eight Channel Modules. Each Channel Module can monitor one sensor.

### 2.2 System Chassis

All electrical connections are located on the rear of the system chassis. There are nine terminal strips, one for each of the Channel Modules and one for the Control Module.

### 2.3 Control Unit

The Control Unit provides control of electrical power to the channel module, audio alarms and external alarms through the common alarm relays. The front panel of the Control Unit is shown in Figure 2-1

Alarm signals from any Channel Module trigger the corresponding relays in the Control Unit. For example, “alarm 1” signals from any channel trigger the “alarm 1” relay in the system control module. There are three such relays in the Control Unit, one each for alarm 1, alarm 2, and failure alarms. The failure alarm relay in the Control Unit is operated “fail-safe”; however, the gas level alarm relays can be optionally connected for operation in the “non fail-safe” mode by setting the configuration jumpers as indicated in the installation section 3.6.2. Each of these relays provides SPDT contacts for operation of external devices.

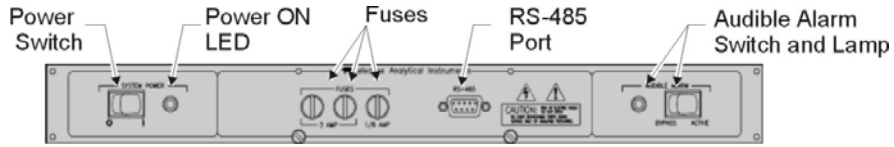

Figure 2-1: Control Unit Front Panel

An audible alarm is actuated when any alarm state occurs. This audible alarm may be disconnected by switching the AUDIBLE ALARM control switch to the BYPASSED position. When this is done, the red lamp on the system module is illuminated as an indication that the audible alarm is not functioning. A block diagram of the Control Unit is shown in Figure 2-2.

The Control Unit is the power entry and distribution point. The 3220 system contains universal power supplies that operate on 100-240 VAC, 50/60Hz. The power switch on the Control Unit switches power for the entire system. The line is protected by two 3 Amp fuses, accessible from the front panel.

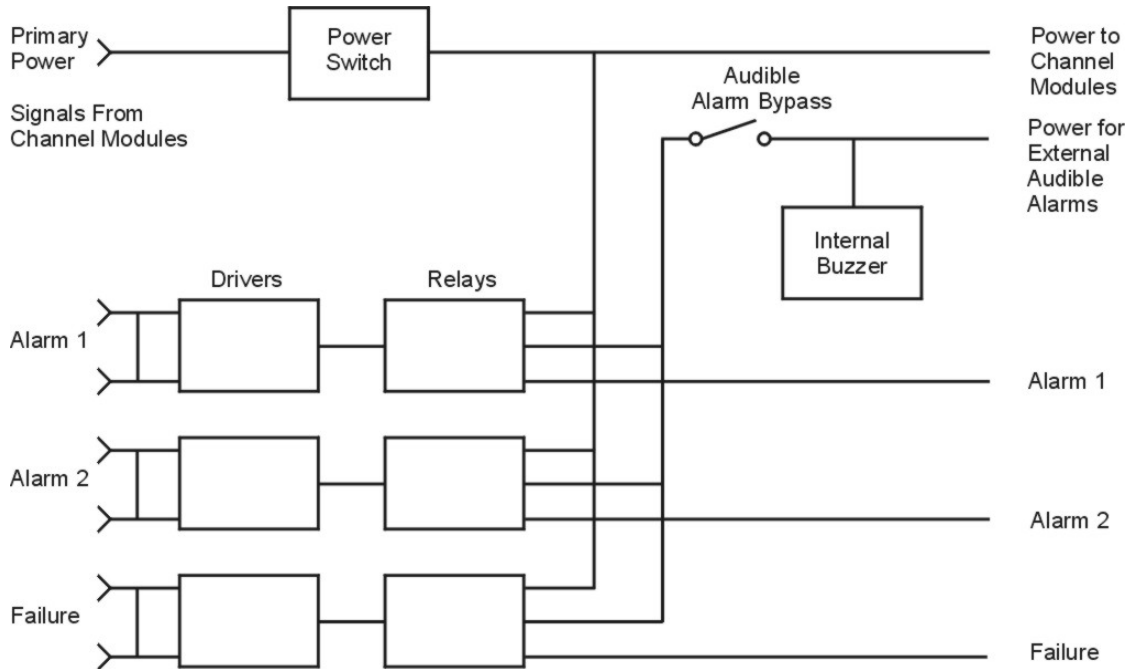

Figure 2-2: Control Unit Block Diagram

A 1/8 A fuse is furnished for the electronic circuitry of the Control Unit. The green power LED indicates that the Unit is ON.

Alarm switch S2 has two positions. Normally, the switch is set to the ACTIVE position which provides for audible alarm when any of the Channel Modules goes into the alarm state. When set to the BYPASS position, the local audible alarm is turned off.

## **2.4 Channel Module**

The Model 3220 Oxygen Gas Analyzer uses an Intel Microcontroller with on-board RAM and ROM to control all signal processing, input/output, and display functions for the analyzer. The channel power is supplied from separate universal power supply modules (100-240 VAC), designed to be compatible with most international power sources. The power supply (triple outputs) supplies the voltages for logic devices and analog circuitry.

A block diagram of the functional relationships of the Channel Module is shown in Figure 2-3.

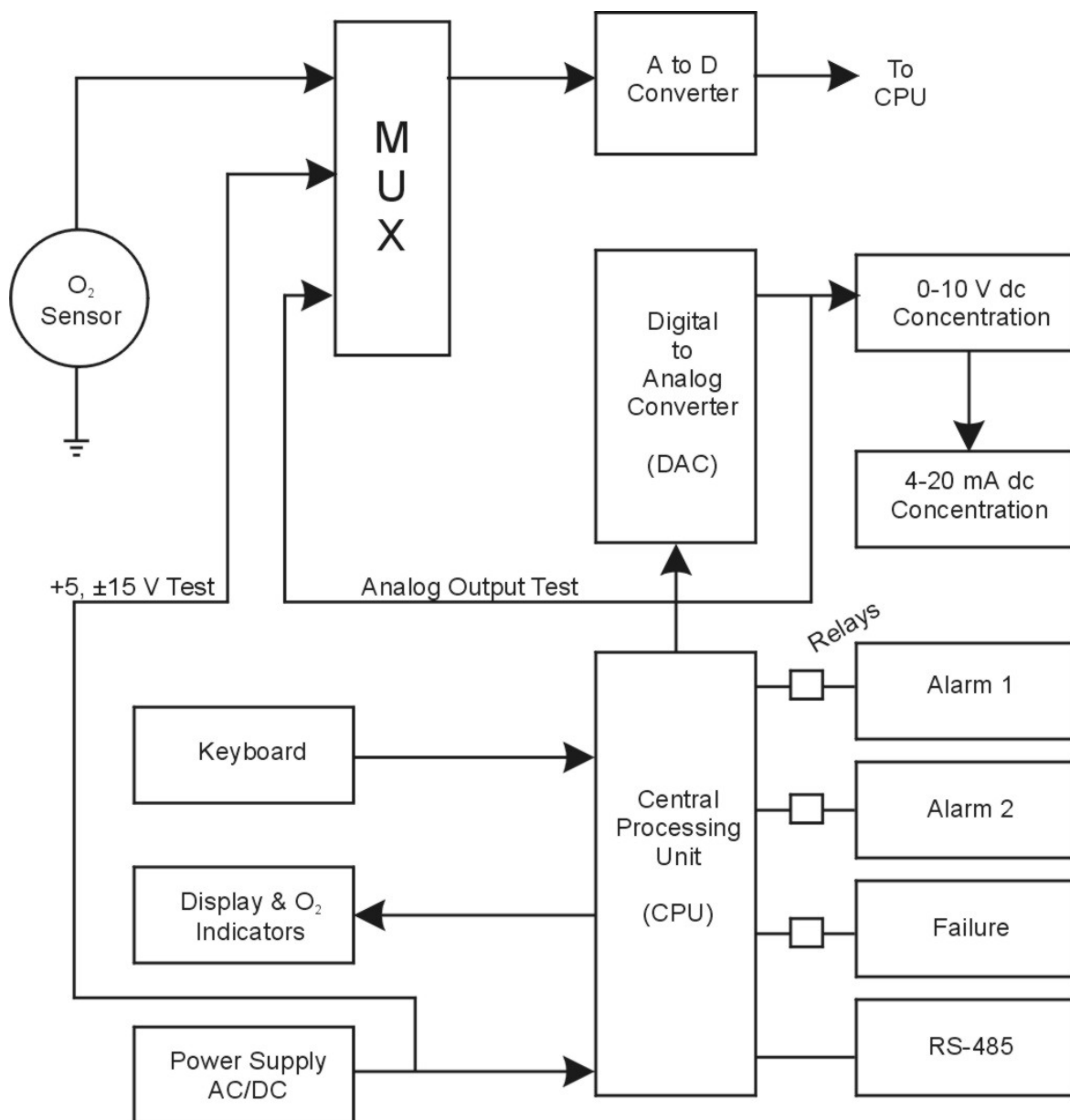

Figure 2-3: Block Diagram of the Signal Processing Electronics



## 2.5 Micro-fuel Cell

The oxygen sensor used in the Model 3220 Oxygen Monitor is a Micro-fuel Cell designed and manufactured by Teledyne Analytical Instruments. It is a sealed plastic disposable electrochemical transducer.

The active components of the Micro-Fuel Cell are a cathode, an anode, and the 15% aqueous KOH electrolyte in which they are immersed. The cell converts the energy from a chemical reaction into an electrical current in an external electrical circuit. Its action is similar to that of a battery.

There is, however, an important difference in the operation of a battery as compared to the Micro-Fuel Cell. In the battery, all reactants are stored within the cell, whereas in the Micro-Fuel Cell, one of the reactants (oxygen) comes from outside the device as a constituent of the gas being monitored or sampled. The Micro-Fuel Cell is therefore a hybrid between a battery and a true fuel cell. (All of the reactants are stored externally in a true fuel cell.)

### 2.5.1 Anatomy of a Micro-Fuel Cell

The Micro-Fuel Cell is a cylinder only 1 1/4 inches in diameter and 1 inch thick. It is made of extremely inert plastic, which can be placed confidently in practically any environment or sample stream. It is effectively sealed, although one end is permeable to oxygen in the monitoring or sampling environment. The other end of the cell is a contact plate consisting of two concentric foil rings. The rings mate with spring-loaded contacts in the sensor block assembly and provide the electrical connection to the rest of the analyzer. Figure 2-1 illustrates the external features.

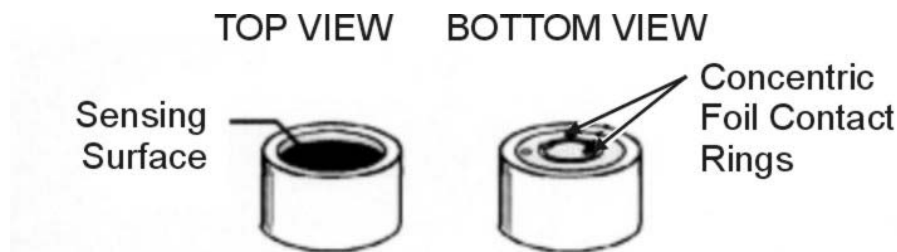
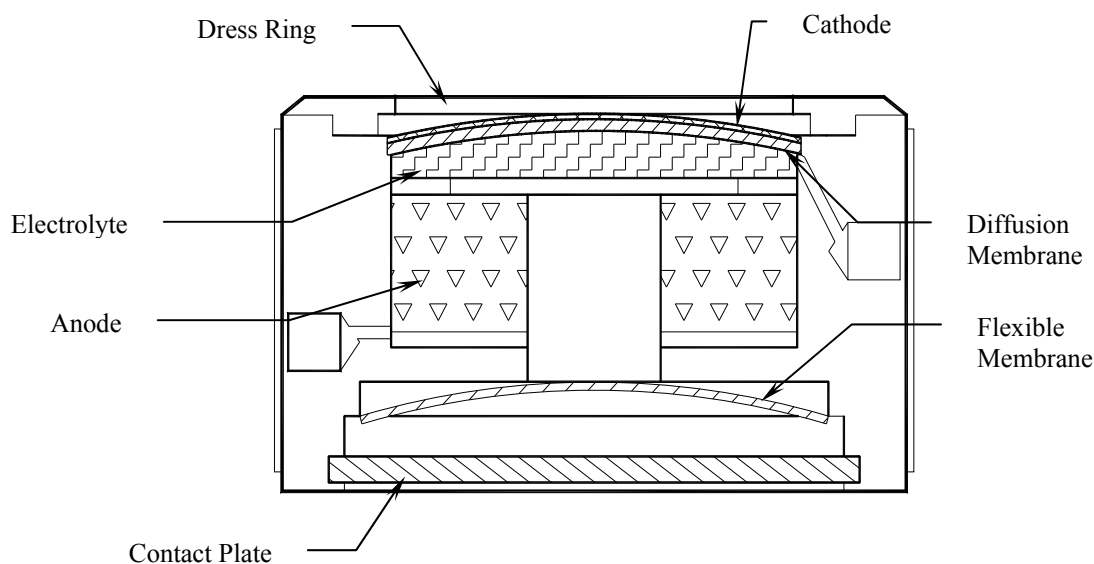

*Figure 2-4: Micro-fuel Cell*

Figure 2-5 illustrates a cross section of a Micro-fuel cell.

At the top end of the cell is a diffusion membrane of Teflon, whose thickness is very accurately controlled. Beneath the diffusion membrane lies the oxygen sensing element the cathode-with a surface area almost  $4 \text{ cm}^2$ . The cathode has many perforations to ensure sufficient wetting of the upper surface with electrolyte, and it is plated with an inert metal.

The anode structure is below the cathode. It is made of lead and has a proprietary design which is meant to maximize the amount of metal available for chemical reaction.

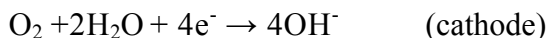

*Figure 2-5: Cross Section of a Micro-fuel Cell*

At the rear of the cell, just below the anode structure, is a flexible membrane designed to accommodate the internal volume changes that occur throughout the life of the cell. This flexibility assures that the sensing membrane remains in its proper position, keeping the electrical output constant. The entire space between the diffusion membrane, above the cathode, and the flexible rear membrane, beneath the anode, is filled with electrolyte. Cathode and anode are submerged in this common pool. They each have a conductor connecting them to one of the external contact rings on the contact plate, which is on the bottom of the cell.

### 2.5.2 Electrochemical Reactions

The sample gas diffuses through the Teflon membrane. Any oxygen in the sample gas is reduced on the surface of the cathode by the following half reaction:



In this reaction, four electrons combine with one oxygen molecule—in the presence of water from the electrolyte—to produce four hydroxyl ions.

When the oxygen is reduced at the cathode, lead is simultaneously oxidized at the anode by the following half reaction:

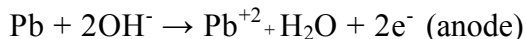

In this reaction, two electrons are transferred for each atom of lead that is oxidized. Therefore it takes two of the above anode reactions to balance one cathode reaction and transfer four electrons.

The electrons released at the surface of the anode flow to the cathode surface when an external electrical path is provided. The current is proportional to the amount of oxygen reaching the cathode. It is measured and used to determine the oxygen concentration in the gas mixture.

The overall reaction for the fuel cell is the SUM of the half reactions above, or:

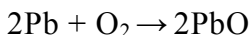

These reactions will hold as long as no gaseous components capable of oxidizing lead—such as iodine, bromine, chlorine and fluorine—are present in the sample.

The output of the fuel cell is limited by:

- (1) the amount of oxygen in the cell at the time and
- (2) the amount of stored anode material.

In the absence of oxygen, no current is generated.

### 2.5.3 The Effect of Pressure

In order to state the amount of oxygen present in the sample as a percentage of the gas mixture, it is necessary that the sample diffuse into the cell under constant pressure.

If the total pressure increases, the rate that oxygen reaches the cathode through the diffusing membrane will also increase. The electron transfer, and therefore the external current, will increase, even though the oxygen concen-

tration of the sample has not changed. It is therefore important that the sample pressure at the fuel cell (usually vent pressure) remain constant between calibrations.

### 2.5.4 Calibration Characteristics

Given that the total pressure of the sample gas at the surface of the Micro-fuel Cell input is constant, a convenient characteristic of the cell is that the current produced in an external circuit is directly proportional to the rate at which oxygen molecules reach the cathode. This rate is directly proportional to the concentration of oxygen in the gaseous mixture. In other words it has a linear characteristic curve, as shown in Figure 2-6. Measuring circuits do not have to compensate for nonlinearity.

In addition, since there is zero output in the absence oxygen, the characteristic curve has close to an absolute zero. In the percent ranges, the cell itself does not need to be zeroed. In practical application zeroing is still used to compensate for zero offsets in the electronics. (The electronics is zeroed automatically when the instrument power is turned on.)

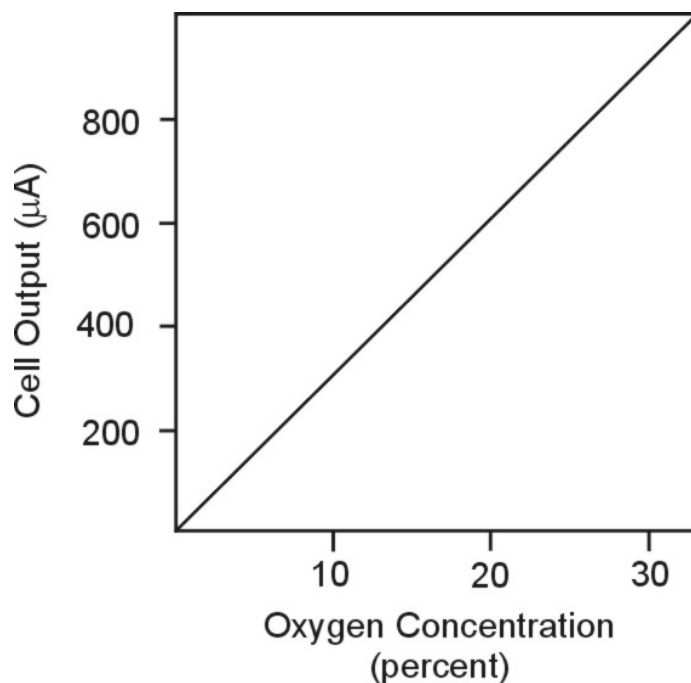

Figure 2-6: Characteristic Input/Output Curve for a Micro-fuel Cell

### **2.5.4 Micro-Fuel Cell “Class”**

TAI manufactures Micro-Fuel Cells with a variety of characteristics to give the best possible performance for any given sample conditions. A few typical Micro-Fuel Cells are listed below with their typical use and electrical specifications.

#### **2.5.4.1 CLASS A-3 CELL**

The class A-3 cell is for use in applications where it is exposed continuously to carbon dioxide concentrations between 1% and 100% in the monitoring environment for example in a flue gas monitoring process.

Nominal output in air is 0.20 mA, and 90% response time is 45 sec. Expected life in flue gas is 8 months. The warranted life of the A-3 cell is 6 months.

*NOTE: In instruments using the A-3 cell, special precaution must be taken to protect the cell from prolonged exposure to high oxygen concentrations such as ambient air.*

#### **2.5.4.2 CLASS A-5 CELL**

The class A-5 cell is for use in applications where it is exposed intermittently to carbon dioxide concentrations up to 100% in the sample gas.

Nominal Output in air is 0.19 mA, and 90% response time is 45 sec. Expected life in a flue gas is 8 months and it is warranted for 6 months.

#### **2.5.4.3 CLASS B-1 CELL**

The class B-1 cell is for use in applications where it is exposed to less than 0.1% of carbon dioxide, and where fast response is important.

Nominal output in air is 0.50 mA, and 90% response time is 7 sec. Expected life in air is 8 months and it is warranted for 6 months.

#### **2.5.4.4 CLASS B-3 CELL**

The class B-3 cell is for use in applications where a slightly longer response time is acceptable in order to have a longer cell life.

Nominal output in air is 0.30 mA, and 90% response time is 13 sec. Expected life in air is 12 months. This cell is warranted for 12 months.

**2.5.4.5 CLASS C-3 CELL**

The class C-3 cell is for use in applications where it is exposed to less than 0.1% of carbon dioxide, and where a longer response time is acceptable in order to have a longer cell life.

Nominal output in air is 0.20 mA, and 90% response time is 30 sec. Expected life in air is 18 months and is warranted for 12 months.

**2.5.4.6 HYDROGEN AND/OR HELIUM SERVICE**

If the sample gas contains 10% or more hydrogen and/or helium, “clamp” cells are used. These Micro-fuel Cells are identified by the suffix -C added to the cell class number.

## Installation

---

Installation of the analyzer includes:

1. Unpacking the system
2. Mounting the Channel Module and Control Module
3. Making the electrical connections
5. Making the gas connections
6. Testing the installation

### 3.1 Unpacking the Analyzer

Each TAI Model 3220 Oxygen Gas Monitoring System is generally shipped with the channel modules and control module installed. Carefully unpack the analyzer and inspect it for damage. Immediately report any damage to the shipping agent.

### 3.2 System Chassis

The physical dimensions and mounting hole spacing for the System Chassis are given on [Drawing C-68499](#). The System Chassis is designed to fit into a standard 19" rack. It requires 7" panel height and 12.3" depth plus allowance for cabling behind the panel.

#### 3.2.1 Location

The System Chassis is designed for installation in a **NON HAZARDOUS** Environment.

#### 3.2.2 Power

The model 3220 is designed to operate from 100/240VAC @ 50/60 Hz. Ventilation must be provided to dissipate heat generated within the control unit. Natural convection is sufficient to cool 16 Channel Modules. However, if more are mounted in the same chassis, forced ventilation should be used.

### 3.3 Electrical Connections

The primary power terminals are designated H (hot), N (neutral) and GND (ground). Connections should be made in accordance with these designations.

All electrical connections are available at the barrier-type terminal strips located at the rear of the control unit. These facilities are shown on the user interconnection [drawing D-17388](#).

**WARNING: DISCONNECT PRIMARY POWER BEFORE MAKING OR CHANGING CONNECTIONS TO ANY OF THE TERMINAL STRIPS.**



Relay contact connections are indicated as NC (normally closed), NO (normally open) and C (common). These designations refer to the contact state when the relay is de-energized.

Sensor connections are indicated as RD (red), WH (white), BK (black) and GN (green). These designations refer to the color of the probe lead wires.

*NOTE: The cable shield should be connected to ground only at one end of the cable (this applies to each probe connection). See Figure 3-1.*

Care must be observed to ensure that the probe leads are not inadvertently connected to the signal common (C) or to the power ground while energized. (See Figure 3-1)

### 3.4 Probe Assemblies

The remote probe assemblies are designated to be flush mounted against a wall or bulkhead (see the outline drawing at the back of this manual for dimensional details). Although the Micro-fuel Cell is position insensitive, it is recommended that the probe assemblies be mounted in either a horizontal or vertical position with the sensing surface pointing sideways or downward, vertical position being preferred and strongly recommended. These positions minimize the effects of particulate matter or water that could deposit or condense on the end of the sensing surface when mounted in an upright vertical position.



There should not be any obstruction in the area immediately around the probe assembly as the Micro-fuel Cell depends strictly on diffusion to sample the atmosphere. Flow-thru adapters may be used when positive pressure sample gas is being analyzed. While the cell is flow insensitive, TAI recommends using flow rates within the range of 0.1 to 10 liters per minute (LPM). Flow rates must be controlled externally. The probe assemblies should be installed in such a manner as to allow personnel access to the cell assembly for cell replacement.

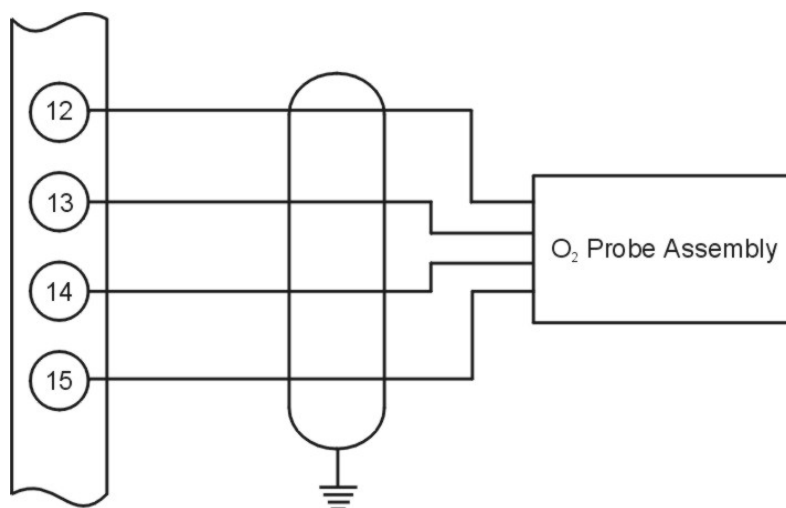

Figure 3-1: Oxygen Probe Assembly

### 3.5 Micro-Fuel Cell

A Micro-fuel Cell is furnished for each remote probe assembly. The cell, as supplied, is packaged in a controlled atmosphere. The following installation procedure should be followed for each probe assembly.

1. Remove the cell from its package taking care not to puncture or tear the thin membrane covering the perforated gold sensing surface.
2. Remove the shorting clip.
3. Unscrew the probe cap and remove it from the probe body.
4. Place the cell with the contact end facing up in the exposed probe cavity and replace the cap.

### 3.6 Control Unit

To remove the Control Unit:

1. Disconnect primary power to the System Chassis
2. Remove the 6 screws around the periphery of the Control Unit front panel.
3. Back out the 2 knurled, slotted jack screws and use these to pull the Control Unit out until it disconnects from its socket.
4. Slide the Control Unit out of the chassis.

To reinstall the Control Unit:

1. Slide the unit into the chassis making certain that the circuit board lines up properly with the connector.
2. Seat the circuit board by tightening the 2 knurled jack screws.
3. Replace the 6 screws about the periphery of the Control Unit.
4. Reapply the primary power to the instrument.

**CAUTION:** **DO NOT HOTSWAP (REMOVE OR INSTALL WITH POWER ON) THE CHANNEL MODULES TO SYSTEM CHASSIS. FAILURE MAY OCCUR BY CAUSING POWER SHORTS WHILE LINING UP THE CIRCUIT BOARD WITH THE BACKPANEL CONNECTOR.**



**INSTALL CHANNEL MODULES STARTING AT THE END OF THE SYSTEM CHASSIS, WORKING TOWARD THE MIDDLE TO PREVENT MISSALIGNMENT PROBLEMS.**

#### 3.6.1 Control Unit Fuses

The Control Unit contains three fuses. Two 3 Amp fuses protect the entire system (one fuse for Hot, one for Neutral). An independent 1/8 Amp fuse protects the Control Unit circuitry. To change any of the fuses, twist the fuse holder knob counterclockwise and slide the holder out until the fuse is visible, install the new fuse, slide the holder back in, and turn the knob clockwise.

### 3.6.2 Control Unit Jumper Settings

The Control Unit may be configured by changing the installation of the jumpers on the PCB. See the following sections for complete jumper installation information. The default jumper installation is shown in the table below.

*Table 3-1: Control Unit Jumper Configuration*

Jumper	Installation	Function
JP1	Pins 1 & 2	Fail-safe Failure Alarm
JP2	Pins 1 & 2	Fail-safe Alarm 2
JP3	Pins 1 & 2	Fail-safe Alarm 1
JP4	Pins 1 & 2	Normally closed ext. aud. Alarm
JP5	Pins 1 & 2	Fail-safe ext. aud. Alarm
JP6	Pins 1 & 2	Ext. aud. contact closures output
JP7	Pins 1 & 2	Ext. aud. contact closures output
JP8 Thru JP16	OFF	RS-485 connections not routed
JP17	ON	Internal aud. Alarm enabled
JP18 & JP19	ON	Ground planes connected

Three alarms (Alarm 1, Alarm 2, and Fail) may be configured for either fail-safe (default) or non fail-safe operation according to the table below:

*Table 3-2: Fail-safe/Non Fail-safe Alarm Configuration*

Alarm	Jumper	Failsafe	Non-failsafe
Alarm 1	JP3	Pins 1 & 2	Pins 2 & 3
Alarm 2	JP2	Pins 1 & 2	Pins 2 & 3
Failure	JP1	Pins 1 & 2	Pins 2 & 3

The external audible alarm may be configured to operate in either the fail-safe (default) mode or the non-fail-safe mode. It may also be configured to provide either a contact closure (default) or the incoming line voltage to the external connections. Additionally, the contact closure can be normally opened or normally closed (when the relay is de-energized). Tables 3-3, 3-4, and 3-5 summarize the jumper settings for the external audible alarm configurations:

*Table 3-3: External Alarm—Failsafe/Non-failsafe Configuration*

Function	JP5 Installation
Failsafe	Pins 1 & 2
Non-failsafe	Pins 2 & 3

*Table 3-4: External Alarm—Contact Closure*

Function	JP4 Installation
Normally Closed (NC)	Pins 1 & 2
Normally Open (NO)	Pins 2 & 3

*Table 3-5: External Alarm—Line Voltage to External Connection*

Function	JP6 Installation	JP4 Installation
Contact closures output	Pins 1 & 2	Pins 2 & 3
Incoming line voltage	Pins 2 & 3	Pins 1 & 2

The internal audible alarm may be disabled by removing JP17.

**WARNING:** **IT IS NOT RECOMMENDED TO REMOVE JP17 UNLESS THERE IS AN EXTERNAL AUDIBLE ALARM IN USE. WITH THE JUMPER REMOVED, THE AUDIBLE ALARM WILL NOT WARN PERSONNEL ABOUT ALARM CONDITIONS.**



### 3.7 Channel Modules

Channel Modules may be removed by first unscrewing the top (retaining) screw and then unscrewing the bottom (jack) screw. As the jack screw is backed out, it will pull the module from its socket. When the jack screw is free, the module may be slid out by pulling on the two screws. In the event it is desired to remove a channel module without disturbing the common alarm circuits, the channel module may be switched into standby mode, by pressing the STANDBY switch (see section 4.3), before removal. Reinstallation of the channel module may be accomplished by sliding the module into the chassis until the top and bottom screws can be engaged, engaging them, tightening the bottom (jack) screw to reconnect the module, and then tightening the top (retaining) screw.

**WARNING:** DISCONNECT POWER BEFORE PERFORMING ANY OF THE FOLLOWING. THESE OPERATIONS SHOULD ONLY BE PERFORMED BY A QUALIFIED SERVICE TECHNICIAN.



#### 3.7.1 Removing the Channel Module Cover

In order to perform the actions in the following sections 3.7.2, 3.7.3 and 3.7.4, the cover of the channel module must be removed. To remove the cover:

1. Unscrew the two 6-32 screws that hold the cover in place.
2. Slide the cover out.

#### 3.7.2 Changing the Fuse

Remove the channel module cover as in section 3.7.1. The fuse is located as shown in the Figure 3-2.

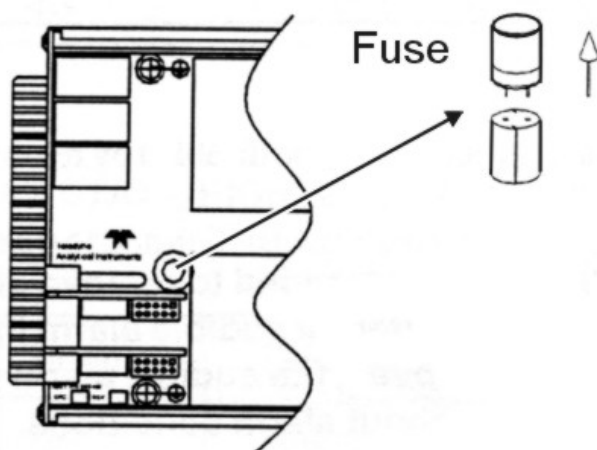

Figure 3-2: Fuse Location

### 3.7.3 Configuring the Internal Jumper Connections

The Channel Module outputs may be configured by setting the internal jumpers. In addition there are several factory preset jumpers configured as shown in the following table. Changing the internal jumpers requires removing the channel module cover as in section 3.7.1.

Table 3-6: Channel Module Internal Jumper Settings

	<b>Standard Jumper Settings (Factory Preset)</b>
JP8	On (Analog/Digital GND)
JP9	On (Analog/Digital GND)
JP10	Pins 2 & 3 (Model Select)
JP11	Pins 2 & 3 (Model Select)
JP12	Pins 2 & 3 (Model Select)
JP13	Pins 2 & 3 (Model Select)
JP15	On (Mode Control)
JP16	On (Mode Control)
JP17	On (Chassis/Digital GND)
JP18	On (Chassis/Analog GND)

The Channel Module is configured to provide an RS485 communication link with the Control Unit (not available at this time). This communication link is not compatible with Control Units having the Common Meter. In order to use the Channel Module with a Control Unit that has a Common Meter, remove jumpers JP1 and JP3 as indicated in Table 3-8.

*Table 3-7: RS-485 Jumper Settings*

	<b>RS-485</b>	<b>Used with Model 3220 With common meter (Default)</b>
JP1	On	Off
JP2	On	Off

The Channel Module can provide one of three forms of output. The output appears at terminal 16 and 17 of the terminal strip, and is selected by jumper setting as indicated in table 3-9.

*Table 3-8: Jumper Settings for Channel Module Output*

	<b>0-10 V Output (Normal)</b>	<b>4-20 mA Output</b>	<b>RS-485 Output</b>
JP2	Off	Off	On
JP4	Off	Off	On
JP5	On	On	Off
JP6	Off	On	Off
JP7	On	Off	Off
JP14	Off	Off	On

## Operation

---

### 4.1 Introduction

Once the System has been Installed, check all wiring to make certain that it is correct. Check that the POWER switch on the Control Unit is in the “OFF” position, then apply primary power to the system. Continue start-up as follows:

1. Check that AUDIBLE ALARM switch is set to BYPASS mode on the Control Unit.
2. Set the Control Unit POWER switch to ON. The *green* power lamp and *red* bypass lamp should be illuminated. All the green Power LEDs on the channel modules should be illuminated.

Each channel goes thru the process of a self-diagnostics test for the following:

- Checks the power supply 5V output
  - Checks the power supply +/-15V outputs
  - Checks the analog outputs
  - Checks that the ADC is responding
3. The Channel Modules are shipped with the ZERO and SPAN preset, and the alarm setpoints at 50% and 80% O<sub>2</sub>. The Channel Module relays revert to normal state after start-up.
  4. After verifying that the Control Unit, and each Channel Module are operating normally, allow the system to stabilize over a 24 hour period.

### 4.2 Control Unit Operations

#### 4.2.1 System Power Switch and LED

The power to the entire 3220 system is controlled by the System Power Switch.

The green System Power LED indicates system power status (ON/OFF).

#### 4.2.2 Audible Alarm Switch and Bypass LED

The Audible Alarm Switch overrides the audible alarm when in the Bypass position. The red Bypass LED lights when the audible alarm is bypassed.



### 4.2.3 Fuses

For fuse replacement/installation, see sections 3.7.1 and 3.7.2

### 4.2.4 RS485 Port

*NOTE: This feature is not presently supported—contact the factory for application assistance.*

An RS485 port is provided at the 9-pin D-sub connector. The RS485 port is connected internally to all of the Channel Modules in the system.

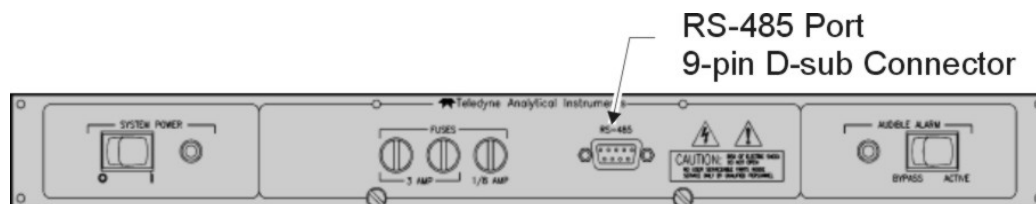

Figure 4-1: RS-485 Port on Control Unit

## 4.3 Channel Module Front Panel Controls and Indicators



**STANDBY** Switch—When pressed, this membrane switch places the Channel Module in the standby mode, i.e., removes power from the sensor(s) and extinguishes the LCD display.

*NOTE: If the relays are configured for fail-safe operation, they will remain energized. If an alarm condition exists, the Channel Module will return to a non-alarm state.*



**RESET** Switch—After an alarm condition is no longer present, as indicated by the concentration value shown on the display, press this membrane switch to return the relay or relays to the non-alarm (normal) state.



**BYPASS** Switch—When in an alarm condition, pressing this membrane switch disables the Control Unit audible alarm.

*NOTE: The red, yellow and blue alarm LEDs begin to flash. They remain flashing until the alarms are reset or the BYPASS switch is pressed again.*



**SELECT Switch**—Use this membrane switch to access any of the Channel Module’s four user-configurable modes and their options. The four modes are:

1. **Calibration Mode**—This mode allows you to select ZERO and SPAN values. It also is used during the “One-Man” (**IMAN**) calibration option.
2. **Alarm Configuration Mode**—This mode allows you to adjust the set points of the concentration alarms as well as define the configuration for the alarms as Hi/Lo, Fail-Safe / Non-Fail-safe, and/or Latching / Non-Latching.
3. **Identification (ID) Code Set Mode**—This mode allows you to define the unique ID for each Channel Module for use with RS-485 communication (Special option, contact factory).
4. **Passcode Enable/Disable Mode**—This mode allows you to enable or disable the factory-defined passcode.
5. **Range Selection**—This mode allows you to set Range 1, Range 2, or Autorange. It also allows you to change their upper limits.
6. **Cell Fail Alarm**—This function allows to set the trigger point of the Cell Fail Alarm in percent Oxygen. The Cell Fail Alarm triggers when the output falls below this value.



**ENTER Switch**—Use this membrane switch in conjunction with the SELECT Switch to select a user-configurable mode and then the option highlighted.



**RUN Switch** - Pressing this membrane switch places the Channel Module in the analysis mode, i.e., the unit is operational.



When in one of the four user-configurable modes, these arrows allow you to navigate through the options. In addition, the UP/DOWN arrow keys can be used to:

- set the values shown on the display for ZERO and SPAN
- increase/decrease the setpoint value of Alarm 1 and Alarm 2.



**Red LED**, when illuminated indicates Alarm 1 conditions. The LED flashes when bypassed.



Yellow LED, when illuminated indicates Alarm 2 condition. It also flashes when bypassed.



Blue LED, when illuminated indicates a Channel Module or Cell Failure. The LED flashes when bypassed.



Green LED remains on during operation. It turns off in STANDBY mode.

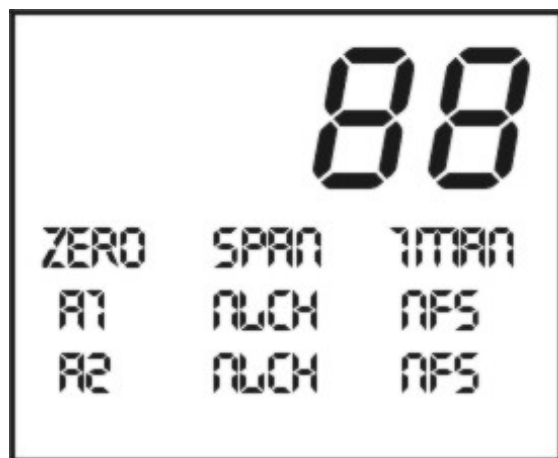

Figure 4-2: Display Panel Configuration

**ZERO**  
**SPAN**  
**1MAN**

This option is used to zero (“0”) calibrate the Channel Module.

This option is used to span calibrate the Channel Module.

This option enables a single person to perform both a zero and span calibration.

**A1**

“**A1**” highlighted indicates that the Alarm 1 value can be set by using the Up/Down Arrow Keys.

**A2**

“**A2**” highlighted indicates that the Alarm 2 value can be set by using the Up/Down Arrow Keys.

**LCH**    **NLCH**

When the instrument goes into an alarm condition, the alarm relay switches. If “**LCH**” (latched) was selected, the alarm relay remains switched (latched) even after the alarm condition has been cleared. Using this configuration, you must press the RESET switch to unlatch (unlock) the relay.

When the instrument goes into an alarm condition, the alarm relay switches. If “**NLCH**” (non-latched) was selected, the alarm relay switches (unlatches) when the alarm condition is cleared.

**R1**    **R2**

“**R1**” and “**R2**” indicate which range is being selected.

**A**    **F**

“**A**” or “**F**” Selects whether the analyzer is autoranging or fixed in a particular range.

CF

“CF” sets the cell failure trigger point.

FS

NFS

If “FS” is selected, the associated relay is in the Fail-safe Mode, i.e., the relay is “normally energized”.

If “NFS” is selected, the associated relay is in the Non-Fail-safe Mode, i.e., the relay is “normally de-energized”.

L

H

“L” or “H” selects whether an alarm is HIGH or LOW.

The LCD Display shows the % O<sub>2</sub> in monitor (RUN) mode, alarm settings during the configuration mode and calibration values during SPAN and ZERO operations.

8.8.8.8

**LCD Display**—The LCD display shows the % O<sub>2</sub> in monitor (RUN) mode, alarm settings during configuration mode, and calibration values during ZERO and SPAN operations.

## 4.4 Calibration Procedures

### 4.4.1 Zero Calibrating a Single Sensor Channel Module

*NOTE: To accomplish the following task, two operators are needed. Operator one at the Control Unit and operator two at the probe. Both operators are involved in the calibration process. They must be in constant communication, by phone or other means.*

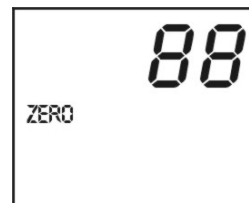

(A) = Operator One at the Control Unit

(B) = Operator Two at the probe

1. (A) At the Front Panel of the Channel Module to be calibrated:
  - a. Press **SELECT**.
  - b. Use the right or left arrow key to highlight the **ZERO** option.
  - c. Press **ENTER**.

Result: Alarms are deactivated and the ZERO display option flashes.

2. (B) Introduce zero gas into the sensor.
3. (A) After the reading has stabilized:
  - a. Press the up or down arrow key until the display reads “0”.
  - b. Press **ENTER**.

4. (B) Disconnect the zero gas from the sensor.
5. (A) If necessary, proceed to the previous or next procedure. Otherwise, press **RUN** to place the instrument in the analysis mode.

#### 4.4.2 Span Calibrating a Channel Module

*NOTE: To accomplish the following task, two operators are needed. Operator one at the Control Unit operator two at the probe. Both operators are in the calibration process. They must be in communication, by phone or other means.*

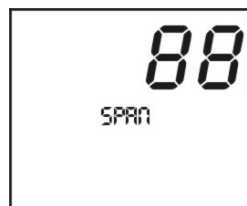

*operators and involved constant*

(A) = Operator One at the Control Unit

(B) = Operator Two at the probe

1. (A) At the Front Panel of the Channel Module to be calibrated:
  - a. Press **SELECT**.
  - b. Use the right or left arrow key to highlight the **SPAN** option.
  - c. Press **ENTER**.  
Result: Alarms are deactivated and the **SPAN** display option flashes.
2. (B) Introduce span gas into sensor. Select span gas that is 80 to 90 % of the upper limit of the range of interest.
3. (A) After the reading stabilizes:
  - a. Press the up or down arrow key until the display reads the value that corresponds to the % O<sub>2</sub> of the certified span gas used.
  - b. Press **ENTER**.
4. (B) Disconnect the span gas from the sensor.
5. (A) If necessary, proceed to the previous or next procedure. Otherwise, press **RUN** to place the instrument in the analyze mode.

#### 4.4.5 Using the "1MAN" Calibration Option

The two following calibration procedure can be performed by one technician.

##### 4.4.5.1 ZERO AND SPAN CALIBRATING A CHANNEL MODULE

1. Start by flowing gas that is less than 1% O<sub>2</sub> to the probe. Then, at the Front Panel of the Channel Module



to be calibrated:

- a. Press **SELECT**.
  - b. Use the right or left arrow key to highlight the **1MAN** option.
  - c. Press **ENTER**.
2. At the remote probe site, introduce certified span gas to the sensor.
  3. Wait 60 seconds so that the reading can stabilize.
    - a. Note: wait 120 seconds if using A3 or A5.
  4. Remove the span gas and introduce zero gas to the sensor.
  5. Wait 60 seconds so that the reading can stabilize.
    - a. Note: wait 120 seconds if using A3 or A5.
  6. At the Front Panel of the Channel Module being calibrated:
    - a. Press the up or down arrow key until the display reads “0”.
    - b. Press **ENTER**.
    - c. Press the up or down arrow key until the display reads the value that corresponds to the value of the certified span gas used.
    - d. Press **ENTER**.
  7. If necessary, proceed to the previous or next procedure. Otherwise, press **RUN** to place the instrument in the analysis mode.

## 4.5 Alarm Configuration Procedures

### 4.5.1 Defining the Setpoint for Alarm 1 and Alarm 2

1. At the Front Panel of the Channel Module to configured:

- a. Press **SELECT** twice to enter the “Configuration” Mode. (“A1” {Alarm flashing.})

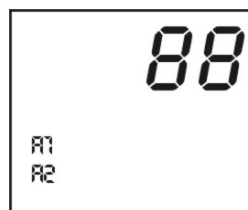

be

“Alarm 1” will be

- b. Use the up or down arrow key to highlight the appropriate alarm to be defined (“A1” = Alarm 1 or “A2” = Alarm 2).
- c. Press **ENTER** to select the alarm.

- d. Use the up or down arrow key to adjust the displayed value to the desired percentage for the alarm selected.
  - e. Press **ENTER**.
2. If necessary, proceed to the previous or next procedure. Otherwise, press **RUN** to place the instrument in the analysis mode.

#### 4.5.2 Configuring Alarm Relay Settings

##### 4.5.2.1 SETTING THE FAIL-SAFE OR NON-FAIL-SAFE MODE

1. At the Front Panel of the Channel Module configured:
  - a. Press **SELECT** twice to enter the "Configuration" Mode. ("A1" will be flashing.) The settings of on the same line where **A1** is and the settings of Alarm 2 are on the same line where **A2** is on the LCD.
  - b. Use the up or down arrow key to highlight the appropriate alarm to be defined ("A1" = Alarm 1 or "A2" = Alarm 2).
  - c. Use the left or right arrow key to highlight the "FS" option.
  - d. Press **ENTER**.
  - e. Use the up or down arrow key to switch to the desired configuration for the alarm ("FS" = Fail-safe and "NFS" = Non-Fail-safe.)
  - f. Press **ENTER**.
2. If necessary, proceed to the previous or next procedure. Otherwise, press **RUN** to place the instrument in the analysis mode.

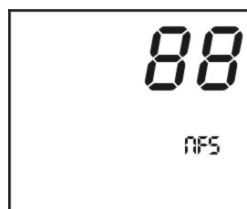

to be

"Alarm  
{Alarm 1}  
Alarm 1 are  
flashing,

##### 4.5.2.2 SETTING THE LATCHING OR NON-LATCHING MODE

1. At the Front Panel of the Channel Module to be configured:
  - a. Press **SELECT** twice to enter the "Alarm Configuration" Mode. ("A1" {Alarm 1} will be flashing.). The settings of Alarm 1 are on the same line where **A1** is flashing, and the settings of Alarm 2 are on the same line where **A2** is on the LCD.
  - b. Use the up or down arrow key to highlight the appropriate alarm to be defined ("A1" = Alarm 1 or "A2" = Alarm 2).
  - c. Use the left or right arrow key to highlight the "LCH" option.
  - d. Press **ENTER**.



- e. Use the up or down arrow key to switch to the desired configuration for the alarm (“**LCH**” = Latching and “**NLCH**” = Non-Latching.)
  - f. Press **ENTER**.
2. If necessary, proceed to the previous or next procedure. Otherwise, press **RUN** to place the instrument in the analysis mode.

#### 4.5.2.3 SETTING ALARMS TO HI OR LO

1. At the Front Panel of the Channel Module to be configured:
  - a. Press **SELECT** twice to enter the “Alarm Configuration” Mode. (“**A1**” {Alarm 1} will be flashing.). The settings of Alarm 1 are on the same line where **A1** is flashing, and the settings of Alarm 2 are on the same line where **A2** is on the LCD.
  - b. Use the up or down arrow key to highlight the appropriate alarm to be defined (“**A1**” = Alarm 1 or “**A2**” = Alarm 2).
  - c. Use the left or right arrow key to highlight either “**H**” or “**L**” (depending on previous setting).
  - d. Press **ENTER**.
  - e. Use the up or down arrow key to toggle the alarm between “**H**” and “**L**” (“**H**” = High Alarm and “**L**” = Low Alarm.)
  - f. Press **ENTER**.
2. If necessary, proceed to the previous or next procedure. Otherwise, press **RUN** to place the instrument in the analysis mode.

## 4.6 Setting the ID Code

1. At the Front Panel of the Channel Module configured:
  - a. Press **SELECT** six times to enter “Code” Mode. (The current ID code displayed.)
  - b. Press **ENTER**.
  - c. Use the left and right arrow key to select the digit to be modified and the up and down arrow keys to modify the selected digit.

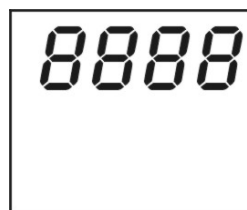

to be

the “ID  
will be

- d. Repeat Step “c” to modify the remaining digits.
  - e. Press **ENTER** to save the ID Code.
2. If necessary, proceed to the previous or next procedure. Otherwise, press **RUN** to place the instrument in the analysis mode.

#### 4.7 Enabling/Disabling the Pass Code

1. At the Front Panel of the Channel Module to be configured:
  - a. Press **SELECT** seven times to enter the “Pass Code” Mode. (The current pass code state {“**Poff**” = Passcode off or “**P on**” = Passcode on} will be displayed.)
  - b. Press **ENTER**.
  - c. Use the up or down arrow key to modify the state of the code.
  - d. Press **ENTER** to accept the change.
2. If necessary, proceed to the previous or next procedure. Otherwise, press **RUN** to place the instrument in the analysis mode. Now, access should be restricted to all functions until passcode is entered.
3. To disable passcode, press **SELECT** once and the LCD will display COdE. While COdE is shown, press the Down arrow key followed by the Right arrow key. Restrictions are now removed temporarily so that you can go back and set “**P off**” = Passcode off again. If you do not set “**P off**”, restrictions will return when analyzer returns to the **Run** mode.

#### 4.8 Range Set-up and Selection

The following should be followed to set-up the ranges. The 3220 Channel module has two ranges. The defaults are: **R1**= 0-25 %, and **R2** = 0-100 % O<sub>2</sub>. This two ranges can be reset to different limits. This only has an effect on the analog output (0-10 vdc output or 4-20 madc output) as the unit will keep track of the oxygen reading throughout its operating range (which is 0-100 % O<sub>2</sub>) on the LCD display. The analog output can be fixed on one of the two ranges or be allowed to autorange. If you decide to autorange be warned that there are no range ID outputs on this analyzer. It is a limitation due to its backward compatibility to its predecessor available outputs.

1. Press **SELECT** three times. **R1** should flash on the LCD along with the value of its limit. You can use the arrow keys to toggle between **R1** and **R2**.

2. Select **R1** or **R2** and Press **ENTER** once. Now you can change the limit of the range selected using the up or down arrow keys.
3. Press **ENTER** to accept new limit.
4. Press **SELECT** one more time and LCD should show on of the following options: “**A**”= autorange, “**R1 F**”= fixed on range 1, or “**R2 F**”= fixed on range 2.
5. Press **ENTER** and use the up or down arrow keys to configure whether the analog output will be fixed on a particular range or it will be allowed to autorange.
6. Press **ENTER** to accept the change.
7. If necessary, proceed to the previous or next procedure. Otherwise, press **RUN** to place the instrument in the analysis mode.

#### 4.9 Cell Failure Set-up

1. To set the trigger point of the cell failure alarm, press **SELECT** five times.
2. The LCD should display “**CF**” = Cell Failure and its trigger value. Press **ENTER** to enter the modification mode.
3. Use the up or down arrow keys to change the oxygen value below which the cell failure alarm will trigger.
4. Press **ENTER** to accept the change.
5. If necessary, proceed to the previous or next procedure. Otherwise, press **RUN** to place the instrument in the analysis mode.

**NOTE: SETTING THE CF VALVE TO ZERO WILL DISABLE THE CELL FAIL ALARM INDICATOR AND RELAY OUTPUT.**

#### 4.10 Routine Operation

During routine operation, the system will require no attention unless an alarm state occurs. In the event of an alarm indication, the audible alarm may be silenced in one of two ways:

1. Move the AUDIBLE ALARM switch on the system control module to BYPASS. This will immediately silence the audible alarm and also prevent an audible indication from occurring should another channel go into an alarm state.

2. Press the BYPASS button on the Channel Module. The associated alarm LED will flash and the AUDIBLE ALARM will be silenced until the ALARM condition is cleared. In this case, only the specific alarm channel will be affected. In the occurrence of an additional alarm in the same channel, or any alarm in any other channel, the AUDIBLE ALARM will again activate.

In either case, once the audible alarm has been silenced the oxygen gas level may be determined by viewing the LCD display reading on the channel module. When the level has diminished to less than the alarm level, the system may be reset by depressing the RESET button.

#### 4.11 FAIL Alarm Conditions

The possible FAIL Alarm Conditions are:

- A cell failure (once the output falls below the programmed trigger point).
- Power supply failure.
- 0-10V Output fails (during start up diagnostic only).
- The ADC times out without a proper end-of-conversion (EOC).

Whenever a failure is detected, the FAIL alarm is activated: the blue LED turns on, the alarm relay is de-energized (the FAIL relay is FAIL-SAFE, and the audible alarm is activated. The power supplies to both sensors are disabled.

Failure alarms are accompanied with a FAIL code number. The display alternates between "FAIL" and the code number.

The failure alarm may be bypassed (by pressing the Bypass Button), in which case, the blue LED flashes, and the audible alarm is deactivated.

To acknowledge a failure condition, press RESET. This restarts the instrument (as if the STNDBY button has been pressed twice). Alternatively, you may turn the unit OFF using the STNDBY button.

*NOTE: The reason the failure modes require restarting the instrument is that once a failure has been detected, the unit should not be used until the error is fixed.*

When a failure alarm is detected, the other two alarms (Alarm 1 and Alarm 2) are disabled.

## Failure and Error Codes

### 5.1 Failure Codes

Failure Code	Failure Indicated	Recommended Action
1	Sensor (S1) failure	Replace the sensor. If this does not correct the problem, check the continuity of all cables and connectors.
5	+5V supply failure	Contact factory
15	+15V or -15V supply failure	Contact factory
34	0-10V DC output failure	Contact factory
67	A to D converter failure	Contact factory

### 5.2 Error Codes

Error Code	Error Indicated	Recommended Action
100	Bad zero error (the zero offset of the sensor appears to be too large)	Check that the correct zero gas was used. Perform a new zero—if this does not correct the problem, install a new sensor.
101	Bad slope error (sensitivity of the sensor measures too large or too small).	Perform a new span calibration—check that the correct span value is entered, corresponding to the certified span gas concentration. If this does not correct the problem,

		install a new sensor.
102	Bad zero and slope error (both the zero and slope are out-of-range)	See recommended actions for errors 100 and 101 listed above.
203	Unstable span error (a stable reading could not be obtained during the span cycle of a 1MAN calibration)	Check the gas connections for leaks and attempt to perform another 1MAN calibration. If this does not correct the problem, install a new sensor.
214	Unstable zero error (a stable reading could not be obtained during the zero cycle of a 1MAN calibration)	Check the gas connections for leaks and attempt to perform another 1MAN calibration. If this does not correct the problem, install a new sensor.

## Appendix

---

### A-1 Specifications

**Range:** 0-25%, 0-100% Oxygen

**Number of Channels:** Up to eight channels

**Repeatability:** 2 % of full scale

**Accuracy:**  $\pm 2\%$  of full scale at constant temperature  
 $\pm 5\%$  of full scale over the working temperature range

**Response Time:** 90% in less than:

B3 -- 13 seconds

B1 -- 7 seconds

A3 -- 45 seconds

A5 -- 45 seconds

**Operating Temperature:** 0 to 50°C

**Alarms:** Two Adjustable Alarm Point plus Failure Alarm Indicators illuminate at Alarm Setpoint.

Alarm 1-RED

Alarm 2-AMBER

Fail-BLUE.

**Signal Output:** Internal: LCD Display  
External: 0-10 VDC or 4-20 mA  
negative ground (user-configurable)

**Power Requirements:** 100-240 VAC 50/60 Hz

**System Enclosure:** Control Module fits standard 19" Relay Rack  
Dimensions: 7" H x 12.3" D x 19" W

**Maximum Loop Resistance for Sensor Connections/Cabling:** 50  $\Omega$

**Maximum Loop Resistance for 4-20 mA OUTPUT:** 600  $\Omega$

**Sensor Probe Mounting:** 2 MTG. Holes , 3/16" Diameter—2 3/8" C-TO-C (custom probes for special applications).

**Field Connections:** Barrier-Type Terminal Strips with screw connections.

**Alarm Output:** Form "C" Relay Contacts (SPDT)

### Recommended Spare Parts List

<b>Qty</b>	<b>Part Number</b>	<b>Description</b>
4	C-6689- (class)	Micro-fuel Cell (class-B1, B3, A5)
5	F-1374	Fuse, Type 3AG, 1/8A
10	F-229	Fuse, Micro, 2A
5	F-1379	Fuse, Type 3AG, 3A
1	C-73638A	PCB, Front Panel Display
1	D-65443B	PCB, Main
1	B-73373	Front Panel With Membrane
1	B16484	Standard Oxygen Probe (1.5 kohm Thermistor)

A minimum charge is applicable to spare parts orders.

*Note: Orders for replacement parts should include the part number (if available) and the model and serial number of the instrument for which the parts are intended.*



Orders should be sent to:

**TELEDYNE Analytical Instruments**

16830 Chestnut Street  
City of Industry, CA 91749-1580

Phone (626) 934-1500, Fax (626) 961-2538  
TWX (910) 584-1887 TDYANYL COID

Web: [www.teledyne-ai.com](http://www.teledyne-ai.com)

or your local representative.

## Drawing List

- C-68499 Outline Drawing, Control Unit
- B-16484 Outline Drawing, Probe Assembly
- C-17388 Interconnection Diagram, Model 3220
- D-73637 Schematic Diagram, Model 3220 Front Panel Display
- D-65442 Schematic Diagram, Model 3220 Main PCB

## Index

---

- IMAN, 27,32,41
- IMAN calibration, 27,32,41
- A displayed, 37
- A1 displayed, 33-35
- A2 displayed, 33-35
- acknowledge failure, 39
- addendum, v
- adding channel modules, 2
- alarm
  - adjust setpoints, 33
  - alarm 2 setting, 33
  - audible, 7,26,38
  - configuring, 33-35
  - failsafe/non-failsafe, 33,34
  - high, 35
  - High/Low, 35
  - latched/non-latched, 34
  - latching/non-latching, 34
  - low, 35
  - relay, 2,6,7,17,21,25-27,29,38
  - setpoint setting, 33
  - signals, 6
  - silence, 38
  - switch, 7,8,25,26,38
- alarm configuration mode, 27
- alarm setpoints
  - initial setting, 23
- alarm switch
  - active position, 8
  - bypass position, 8,26
- alarms
  - fail-safe mode, 21,30,33
  - non fail-safe mode, 21,30,33
- audible alarm
  - bypassing, 7,25-27,38,39
  - disconnecting, 7
- audible alarm switch, 25,26,38
- autorange, 27,37
- autoranging, 30
- auxiliary heating, 4
- block diagram
  - control unit, 7
- blue LED, 28,38,39
- bypass LED, 26
- calibration, 13,30
- calibration mode, 27
- calibration procedures, 30
- caution sign, vii
- cell failure, 37,38
- cell output, 13
- CF displayed, 30,37
- channel module, 1, 2, 3, 6,8
  - features, 2
- channel module calibration. *See* calibration
- chassis. *See* system chassis
- checklist. *See* safety checklist
- configuration jumpers. *See* jumpers
- contacts, 6
- control unit, 2,6,19
  - block diagram, 7
  - front panel, 7
  - jumper settings, 20
- copyright, iv
- diffusion membrane, 11
- display panel, 29
- distance, probe location, 4
- down arrow key. *See* up/down keys
- drawing list, 44
- electrical connections, 17
- electrochemical conversion, 10
- electrochemical reaction, 12
- electrolyte, 10
- electronics block diagram, 9
- enter switch, 28
- error codes, 40,41
- F displayed, 30,37
- fail-safe mode, 21,33
- failure alarm. *See* alarms
- failure alarm conditions, 38
- failure code number, 38
- failure codes, 40,41
- fixed range, 30,37
- flashing LED, 27,28,38
- foil ring, 10
- FS displayed, 33,34
- fuse, 2,7,8,19,22,23,26,43
- green lamp. *See* Power LED

- green LED, 8,25,28
- H displayed, 30,35
- ID code, 35
- identification code, 35
- jumpers, 20,23
- KOH electrolyte, 10
- L displayed, 30,35
- LCD display, 30
- LCH displayed, 29,34
- main power, control of, 2
- manuals, additional, viii
- microcontroller, 8
- micro-fuel cell, 10,11
  - class, 14
  - cross section, 11
  - input/output characteristics, 13
- navigation buttons, 26,27
- NFS displayed, 30,34
- NLCH displayed, 29,34
- non-fail-safe mode, 21,30,34
- one man calibration, 29,32
- oxygen sensor. *See* micro-fuel cell
- Passcode, 36
- passcode mode, 26
- power, 16
- power distribution, 2,7
- power entry, 7
- power LED, 8,26. *See* power supply
- power supply
  - channel module, 8
  - universal, 8
- pressure effects, 12
- R1/R2 displayed, 29
- RAM, 8
- range, 36
- range selection, 36
- red lamp. *See* bypass LED
  - illuminated, 7
- red LED, 28
- relay, 2,6,17,21,25-27,29,30,38
  - fail-safe operation, 20,26
  - failsafe/non-failsafe, 34
  - latching/non-latching, 34
- remote probe, 1, 4
- RS485 port, 26
- run switch, 28
- safety checklist, vi
- safety information, vii
- sample handling equipment, 4
- select switch, 27
- self-diagnostics test, 25
- sensor block assembly, 10
- serial number, v
- setpoint. *See* alarm/setpoint
- socket
  - system chassis, 2
- SPAN
  - calibrate, 32
- span gas, 31
- SPAN values
  - selecting, 31
- spare parts, 43
- specific model information, v
- specifications, 41
- stabilization period, 25
- standby mode, 26
- standby switch, 26
- system chassis, 2
- system description, 1
- system reset, 38
- Teledyne address, 44
- temperature compensation
  - accuracy, 4
  - range, 4
- terminal strips, 6,17
- thermistor, 4
- up/down keys, 28
- user responsibility, vi
- warning sign, vii
- warranty, iv
- website address, viii
- yellow LED, 28
- ZERO
  - calibrate, 30
- ZERO calibration, 30
- zero offset, 13,40
- ZERO values
  - selecting, 30



4 3 2 1 D C B A

NOTES: UNLESS OTHERWISE SPECIFIED.

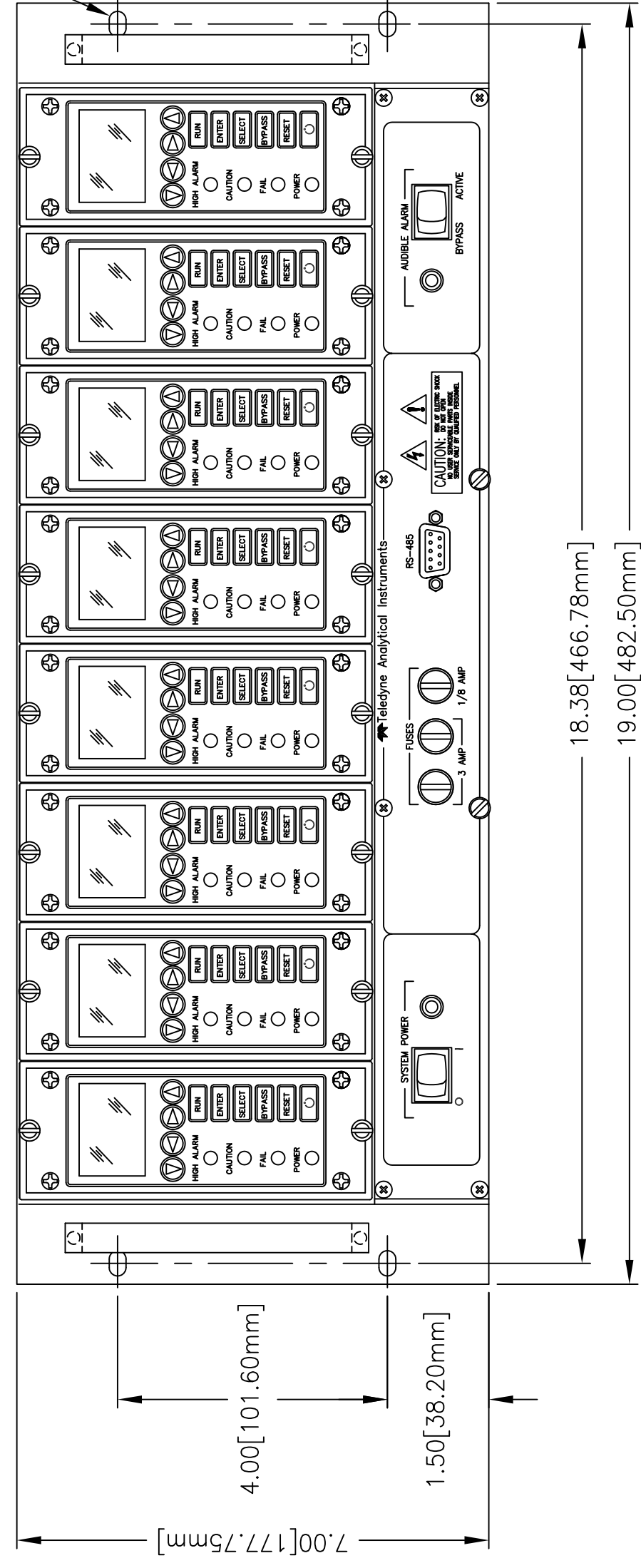
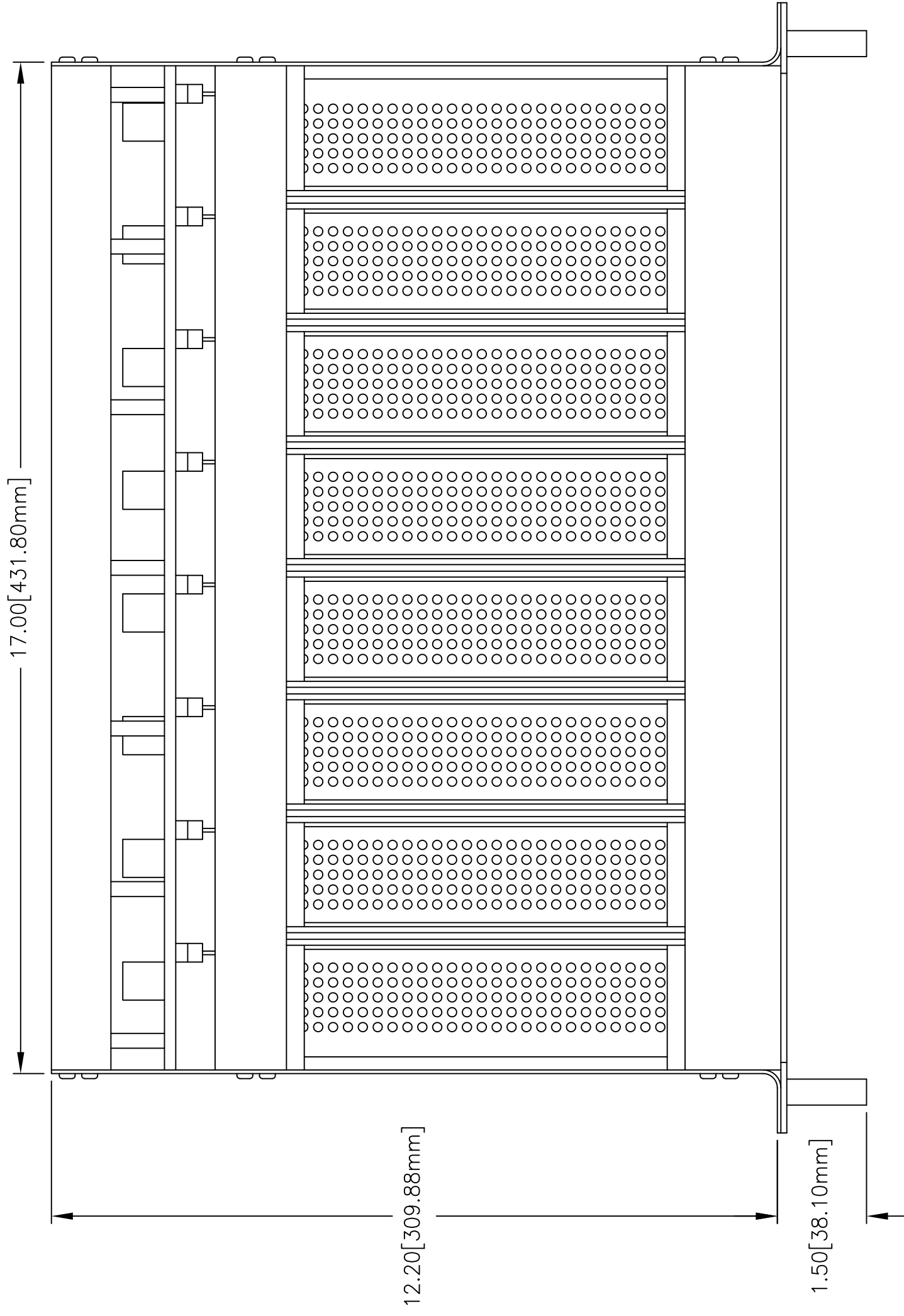

MTG. HOLES FOR #10 SCREWS FOR 4-PLCS

1 1/16" DIA. 2 HOLES THIS SIDE & FAR SIDE FOR 3/4" CONDUIT

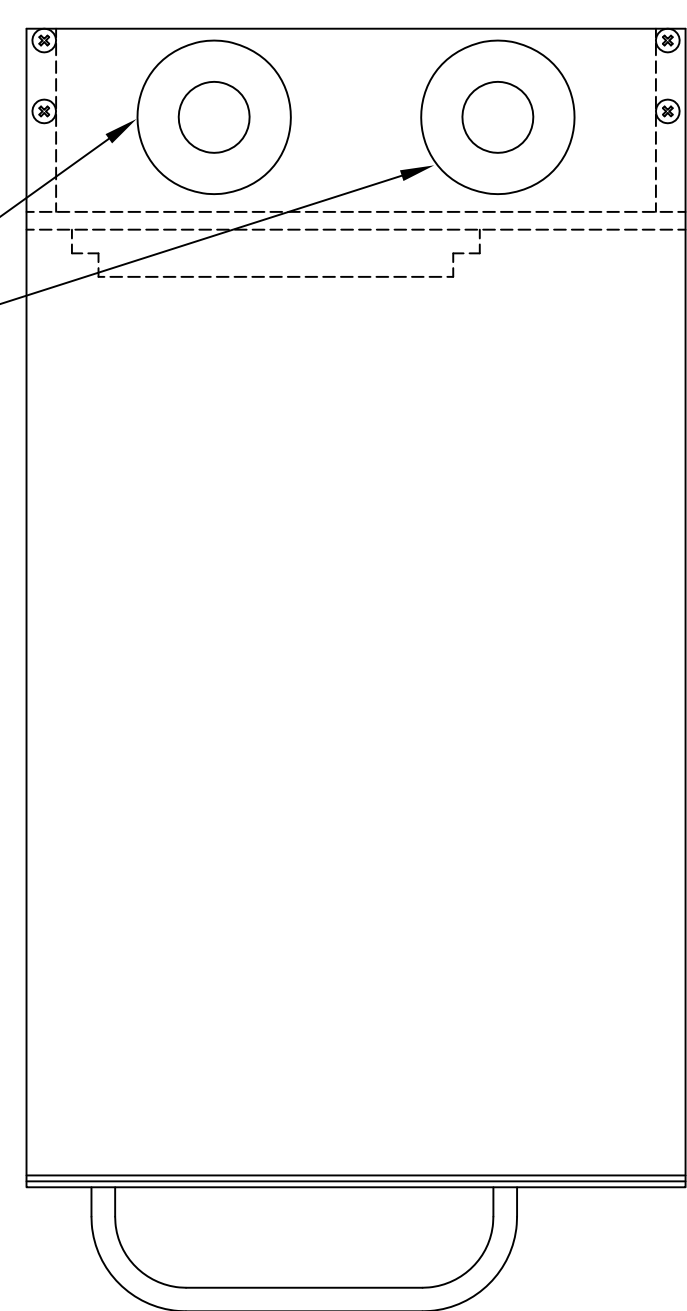

REVISIONS			
REV.	DESCRIPTION	DATE	APP. BY
0	INITIAL RELEASE	6/12/98	WTC

ITEM	QTY	PART NO.	DESCRIPTION
BILL OF MATERIAL			
DO NOT SCALE DWG			
TOLERANCE UNLESS OTHERWISE SPECIFIED: ANGULAR ±1/2°			
LINEAR ±.02			
±.01			
±.005			
±.010			
SIGNATURES		DATE	TITLE
DRFT: WING T CHOW		6/12/97	CONTROL MODULE OUTLINE DIAGRAM MODEL 1220
CHK:			
APPR:			
ENGR:			
S.O.			
CAD ID C68499-0			
REFERENCE			
I/			
N/			
P/			
O/			
F/			
SCALE 1:2			
SIM NONE			
SHEET 1 OF 1			
REV 0			
DWG NO. C-68499			
MATERIAL			

2 3 4 3 2 1

D C B A



NOTES: UNLESS OTHERWISE SPECIFIED.

REV	DESCRIPTION	DATE	APP.	REV. BY
1	Initial Release	8/28/77	JF	---
2	REVISED	11-28-77	JJ	---
3	INC. ECO 05-0160	08/12/05	AA	MN
4	INC. ECO 09-0183	2/19/10	AA	VF

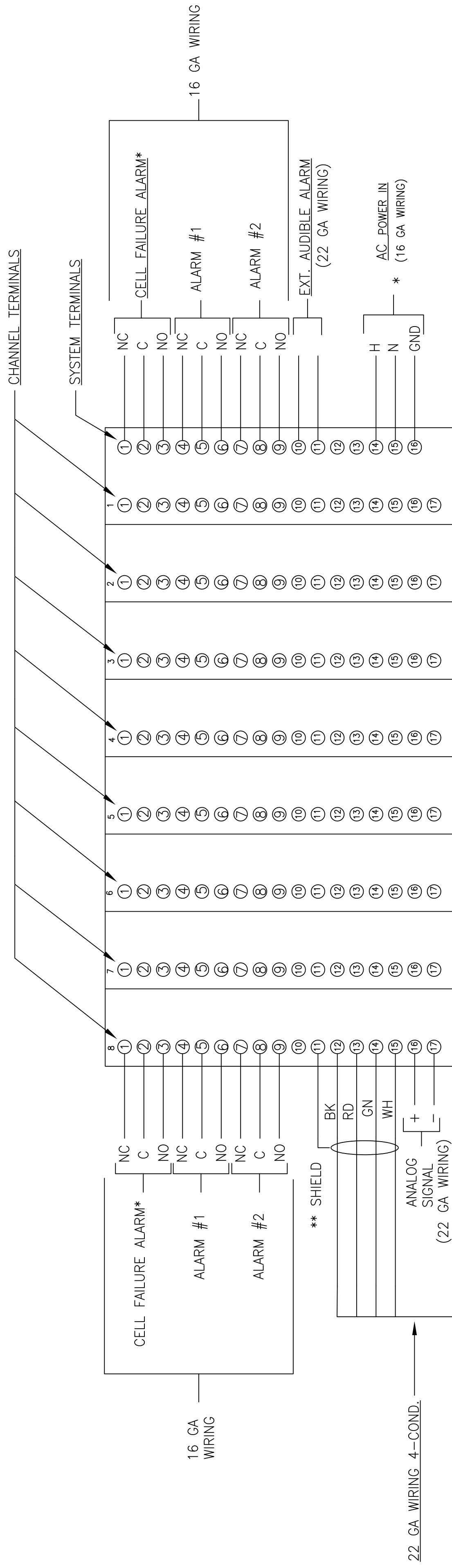

REAR VIEW OF CONTROL UNIT

TO PROBE ASSEMBLY

NOTES:  
 \*\* SHIELD USED FOR 25FT. OR LONGER CABLE  
 \* SELECTED PER APPLICATION

UNLESS OTHERWISE SPECIFIED		TELEDYNE INSTRUMENTS	
UNLESS OTHERWISE SPECIFIED DIMENSIONS ARE IN INCHES		Analytical Instruments	
TOLERANCE		A Teledyne Technologies Company	
ANGULAR ±1/2°	LINEAR ±.010	City of Industry, California, 91746, USA	
SIGNATURES		TITLE	
I/	DRFT: VAP. JR	INTERCONNECTION DIAGRAM	
N/	CHK:	MASTER	
P/	APPR: JF	MODEL 3220	
O/	ENGR: JF	SCALE NTS	
F/	C.O.:	SHEET 1 OF 1	
REFERENCE	CAD ID C17388-4	REV 4	
		DWG NO. C-17388	





4 3 2 1

NOTES: UNLESS OTHERWISE SPECIFIED.

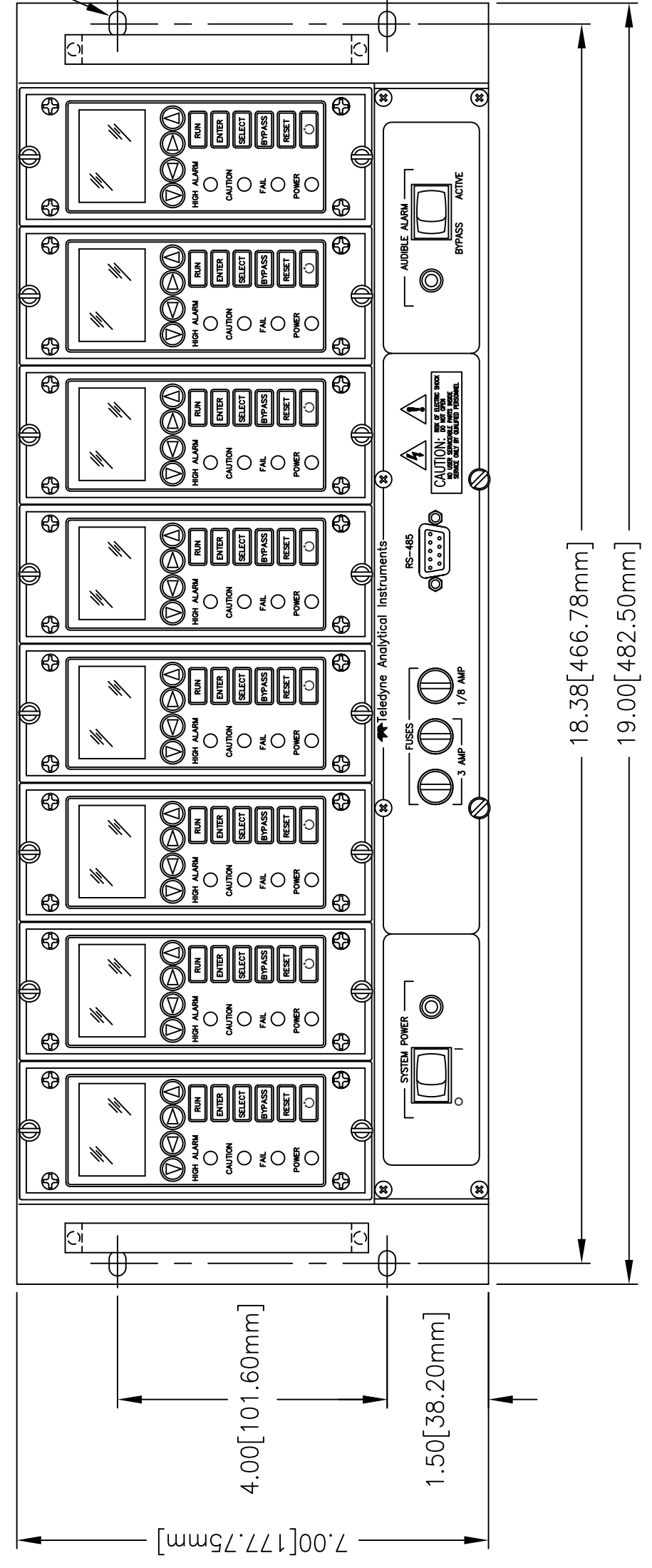
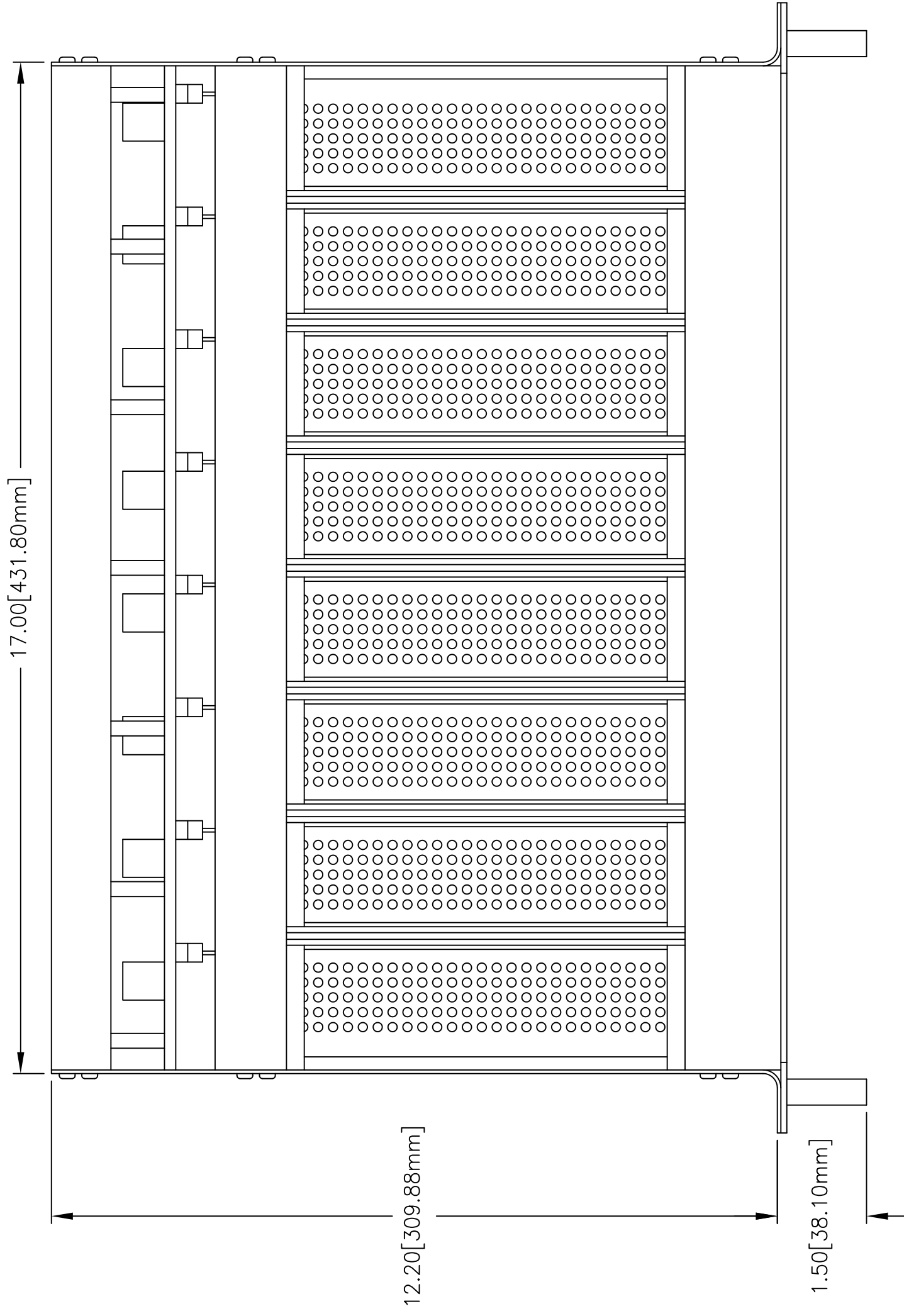

MTG. HOLES FOR #10 SCREWS FOR 4-PLCS

1 1/16" DIA. 2 HOLES THIS SIDE & FAR SIDE FOR 3/4" CONDUIT

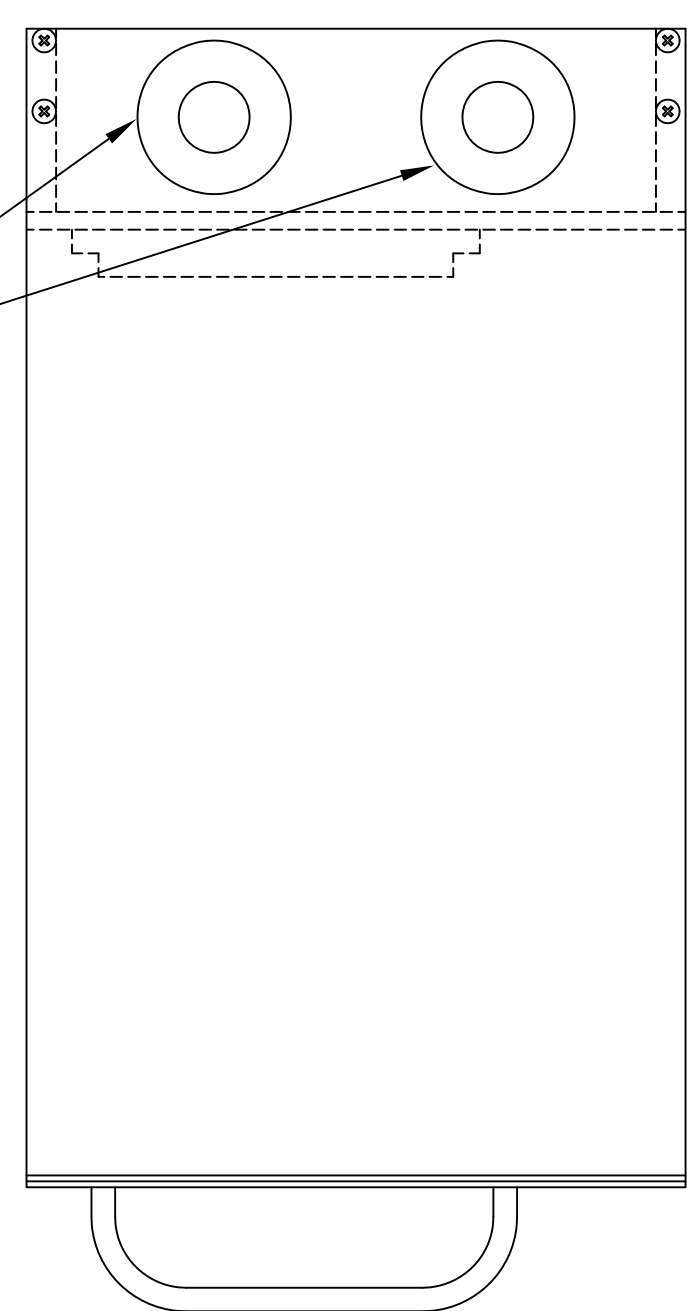

REVISIONS			
REV.	DESCRIPTION	DATE	APP. BY
0	INITIAL RELEASE	6/12/98	WTC

ITEM	QTY	PART NO.	DESCRIPTION
BILL OF MATERIAL			
DO NOT SCALE DWG			
TOLERANCE UNLESS OTHERWISE SPECIFIED: ANGULAR ±1/2°			
LINEAR ±.02			
±.01			
±.005			
±.010			
SIGNATURES		DATE	TITLE
DRFT: WING T CHOW		6/12/97	CONTROL MODULE OUTLINE DIAGRAM MODEL 1220
CHK:			
APPR:			
ENGR:			
S.O.			
CAD ID C68499-0			
REFERENCE			
I/			
N/			
P/			
O/			
F/			
SCALE 1:2			
SIM NONE			
SHEET 1 OF 1			
REV 0			
DWG NO. C-68499			
MATERIAL			

D C B A

4 3 2 1



NOTES: UNLESS OTHERWISE SPECIFIED.

REV	DESCRIPTION	DATE	APP.	REV. BY
0	Initial Release Per ECO 01-0267	2/28/02	TMC	--
1	INC ECO 14-0055	7/20/15	AA	AS

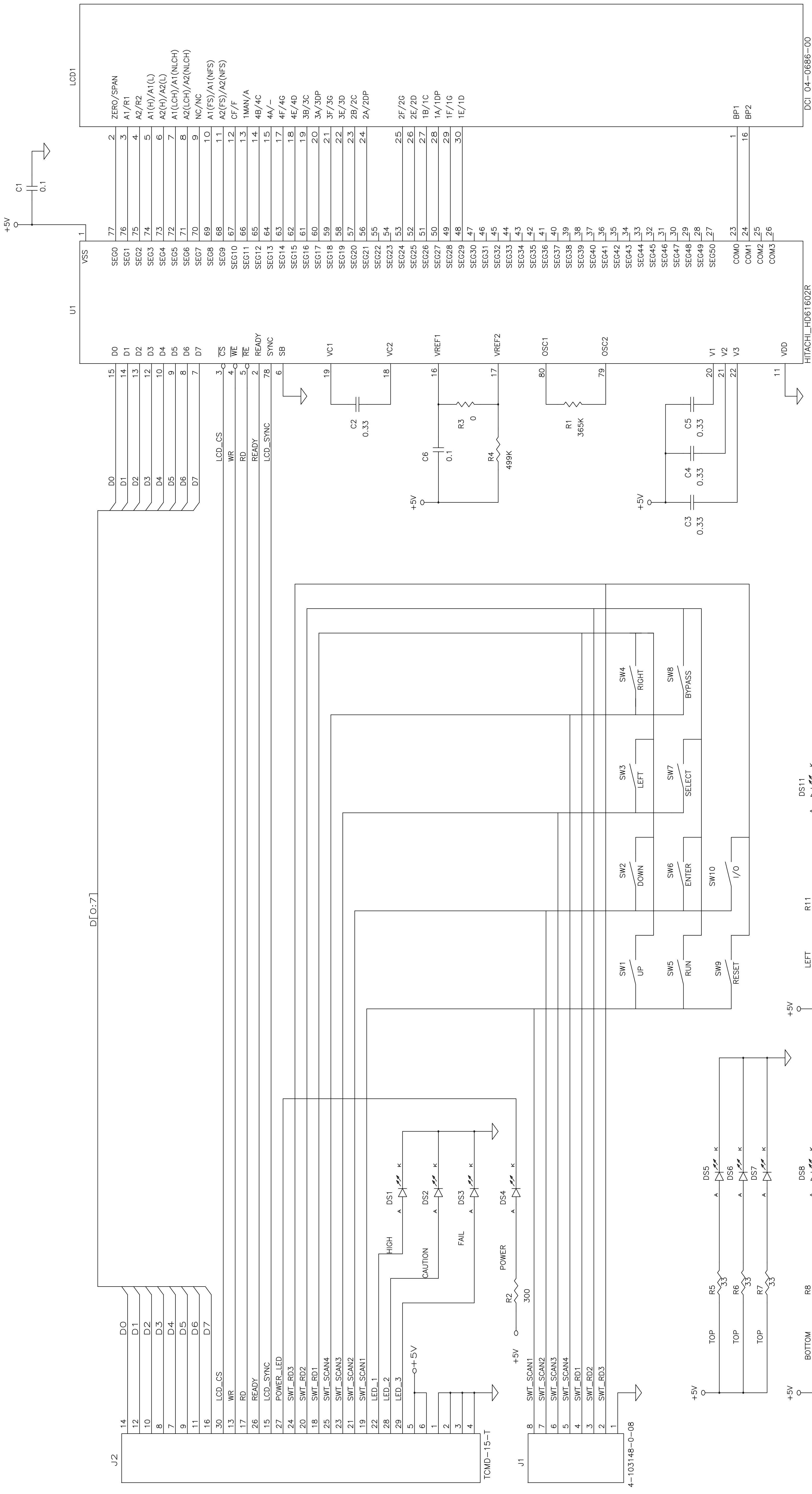

DO NOT SCALE DRAWING		UNLESS OTHERWISE SPECIFIED	
DIMENSIONS ARE IN INCHES		TOLERANCE: ANGULAR ±1/2°	
LINEAR: .XX = ±0.02		.XXX = ±0.010	
SIGNATURES		DATE	
DRFT: T.McINTYRE		4/20/81	
CHK:			
APPR:			
ENGR:			
C.O.:			
REFERENCE:		CAD ID	

THIS DRAWING IS THE PROPERTY OF TELETYPE ANALYTICAL INSTRUMENTS AND CONTAINS CONFIDENTIAL INFORMATION. IT IS NOT TO BE COPIED, REPRODUCED OR USED WITHOUT WRITTEN PERMISSION.	
<b>TELEDYNE</b> Analytical Instruments A Business Unit of Teletype Instruments, Inc. City of Industry, California 91748, USA	
<b>SCHEMATIC DIAGRAM</b>	
<b>FRONT PANEL BOARD</b>	
<b>MODEL 3220</b>	
SCALE	NTS
SIM	
SHEET	1 OF 1
REV.	1
DWG. NO.	<b>D-73637</b>

8 7 6 5 4 3 2 1

8 7 6 5 4 3 2 1

D

C

B

A

D

C

B

A



REV	DESCRIPTION	DATE	APP'D
1	INITIAL RELEASE EOD 97-0004	5/29/77	INC
2	INC EOD 98-0448	11/21/77	AA
3	INC EOD 14-0079	7/27/74	AA

- NOTES: UNLESS OTHERWISE SPECIFIED
1. PREPARED IAW DOCUMENTS LISTED:  
 GRAPHIC SYMBOLS: ANSI Y32.2  
 REFERENCE DESIGNATORS: ANSI Y32.16  
 DEFINITIONS OF ENGR DwgS: ANSI Y14.15
  2. FOR ASSEMBLY SEE 065443.
  3. RESISTANCE VALUES ARE IN OHMS, 1/8W, +/- 1%.
  4. CAPACITANCE VALUES ARE IN MICROFARADS, 50V, +/- 10%.

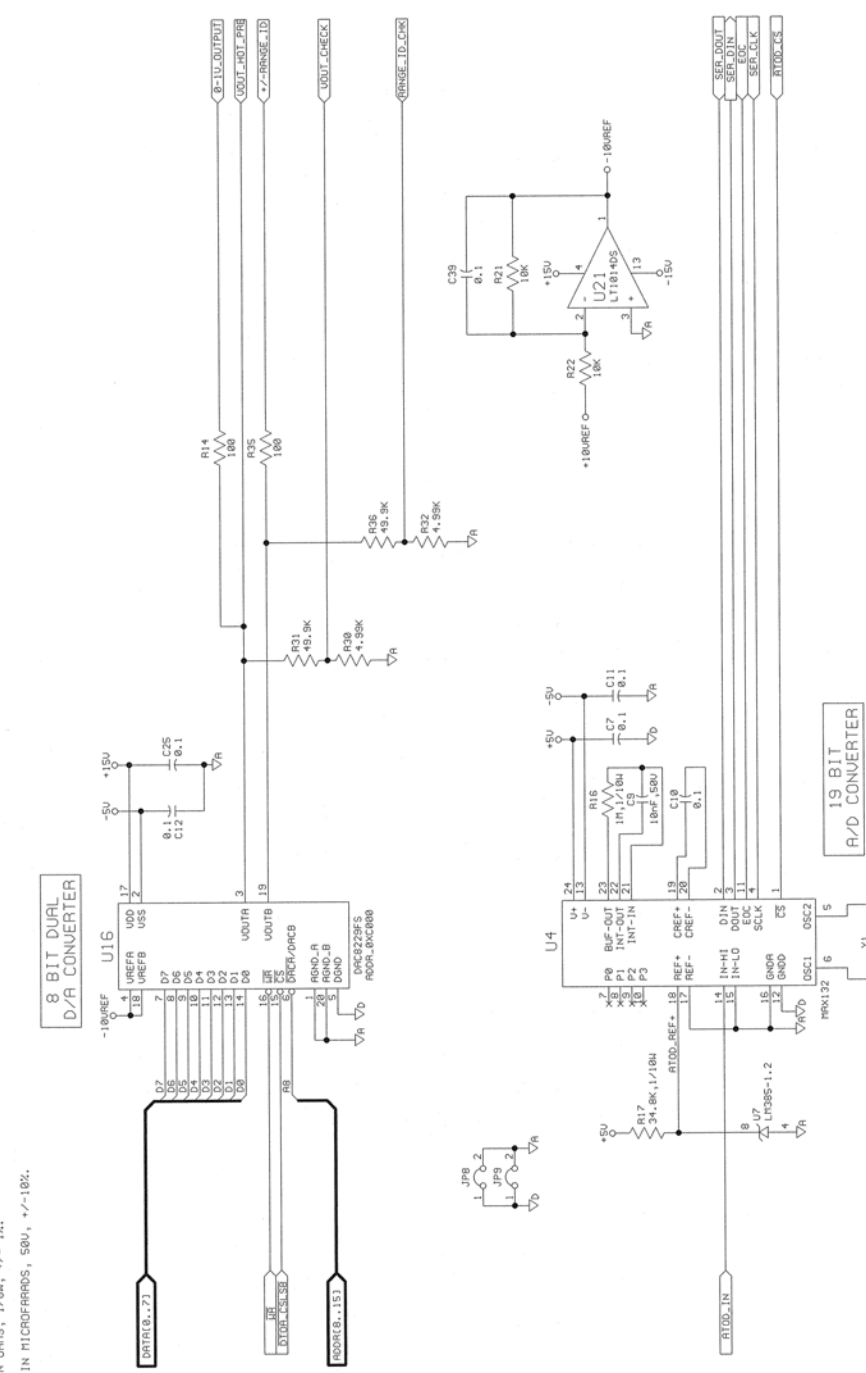

DO NOT SCALE DRAWING  
 UNLESS INDICATED OTHERWISE  
 DIMENSIONS IN INCHES  
 DIMENSIONS IN MILLIMETERS

SCALE	NONE
SHEET	1 OF 8
REV	
DATE	
APP'D	
CHK'D	
INSTR	
DATE	
REV	
DATE	
REV	
DATE	

TELEDYNE ANALYTICAL INSTRUMENTS  
 A BUSINESS UNIT OF TELEPHONE ELECTRONIC TECHNOLOGIES

SCHEMATIC DIAGRAM  
 MODEL 1220 / 3220  
 MAIN BOARD

REV NO. D-65442



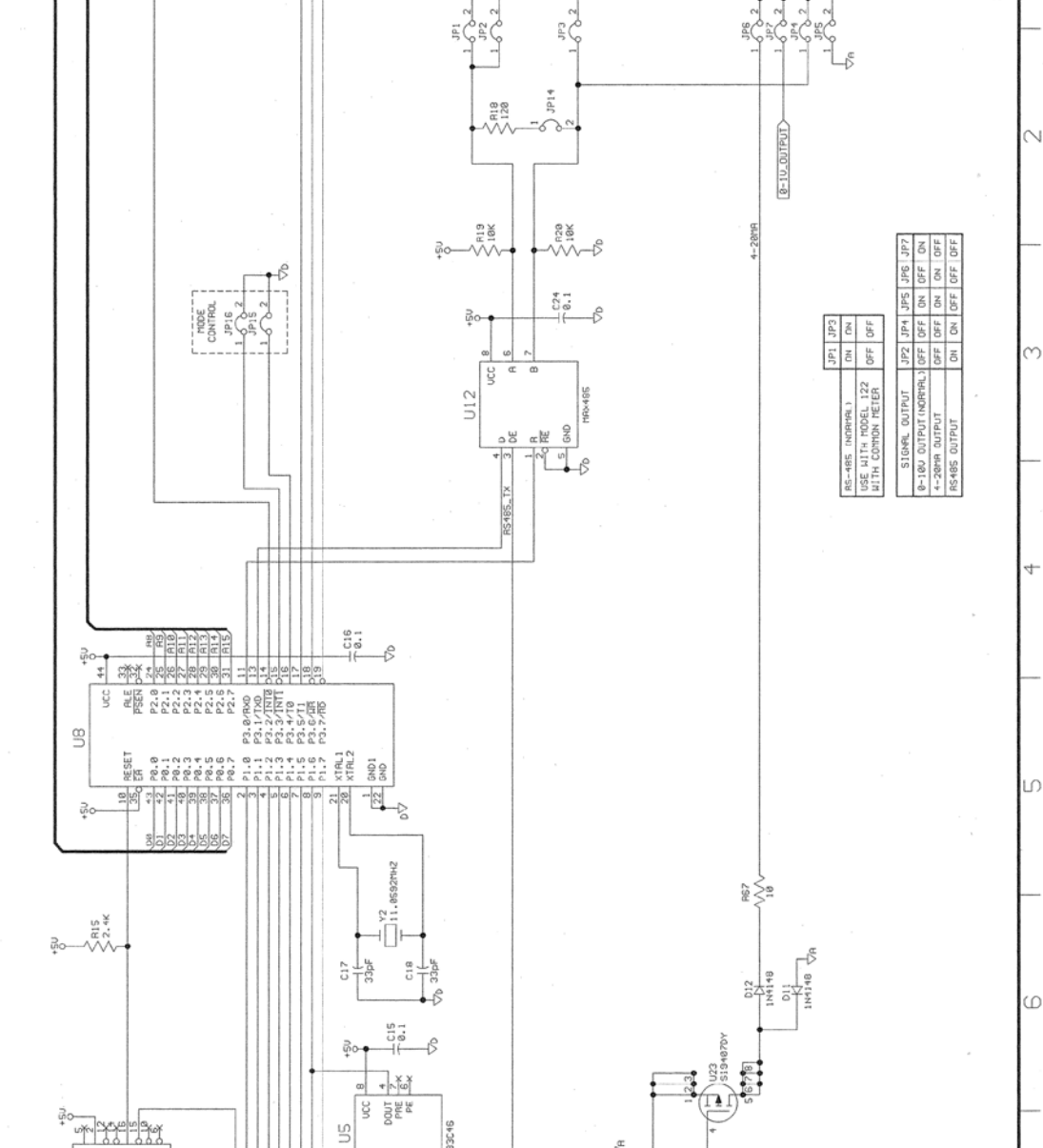

RS-485 IN(NORMAL)	J1	JP3
USE WITH MODEL 122 WITH COMMON METER	DN	DN
	OFF	OFF

SIGNAL OUTPUT	J2	JP4	JP5	JP6	JP7
B-10V OUTPUT(NORMAL)	DN	DN	DN	DN	DN
4-20mA OUTPUT	DN	DN	DN	DN	DN
RS485 OUTPUT	DN	DN	DN	DN	DN
	OFF	OFF	OFF	OFF	OFF

D C B A

1 2 3 4 5 6 7 8





1 2 3 4 5 6 7 8

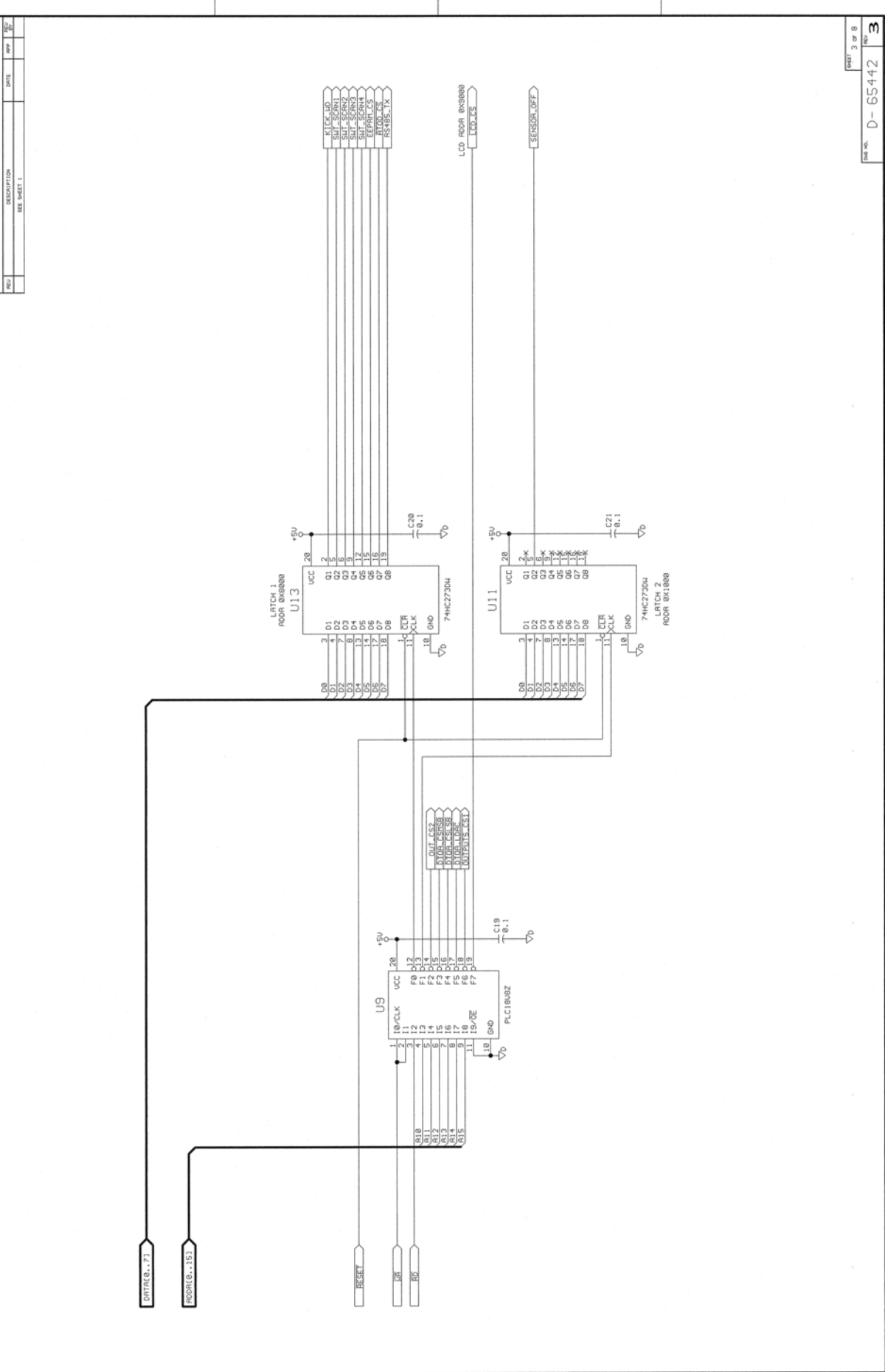

D C B A

REV. NO. D-65442

PREP. J. B. B.

FIG. 3

1 2 3 4 5 6 7 8



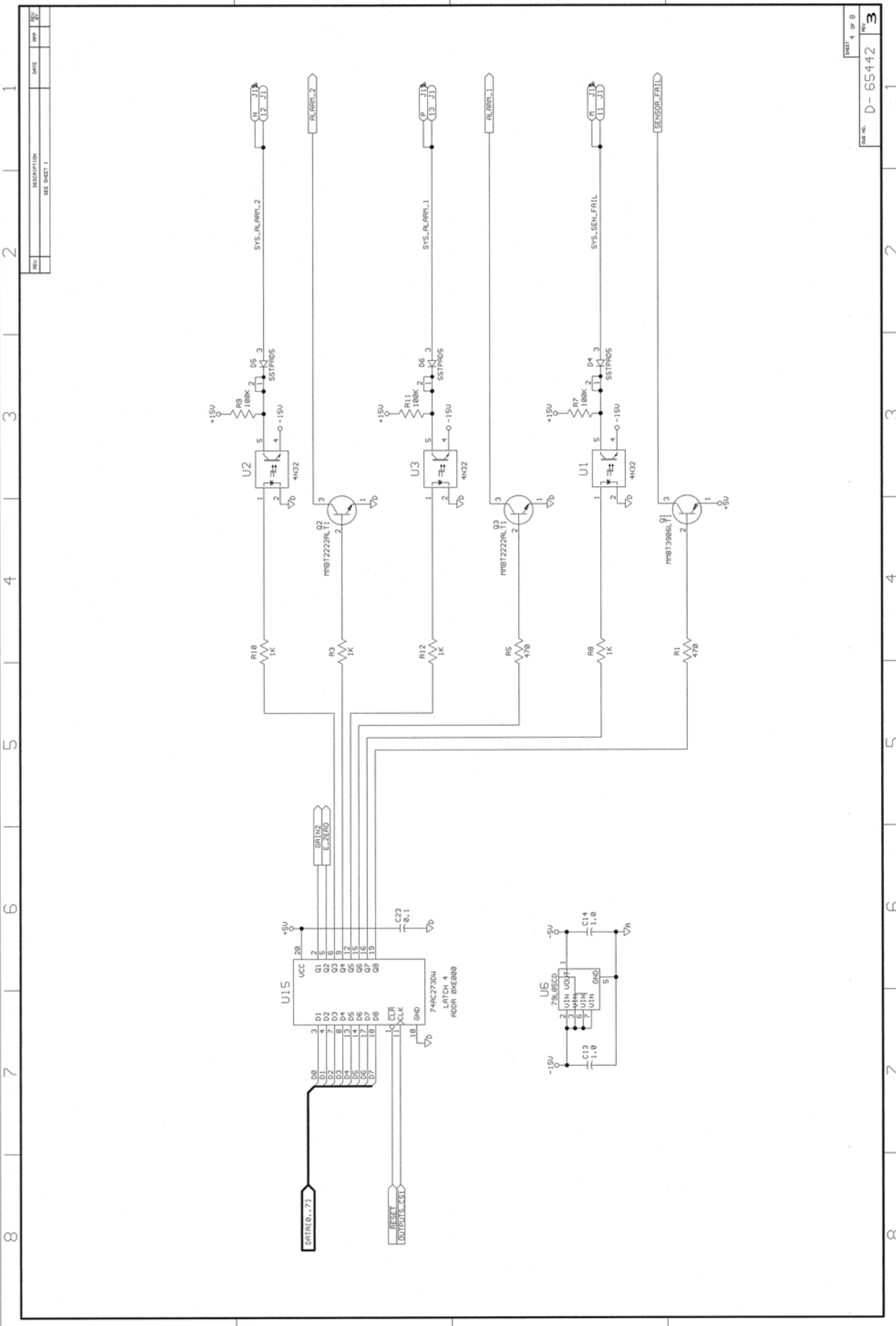

REV	DESCRIPTION	DATE	APP
	SEE SHEET 1		

REV	OF	B
REV	D-65442	
	3	



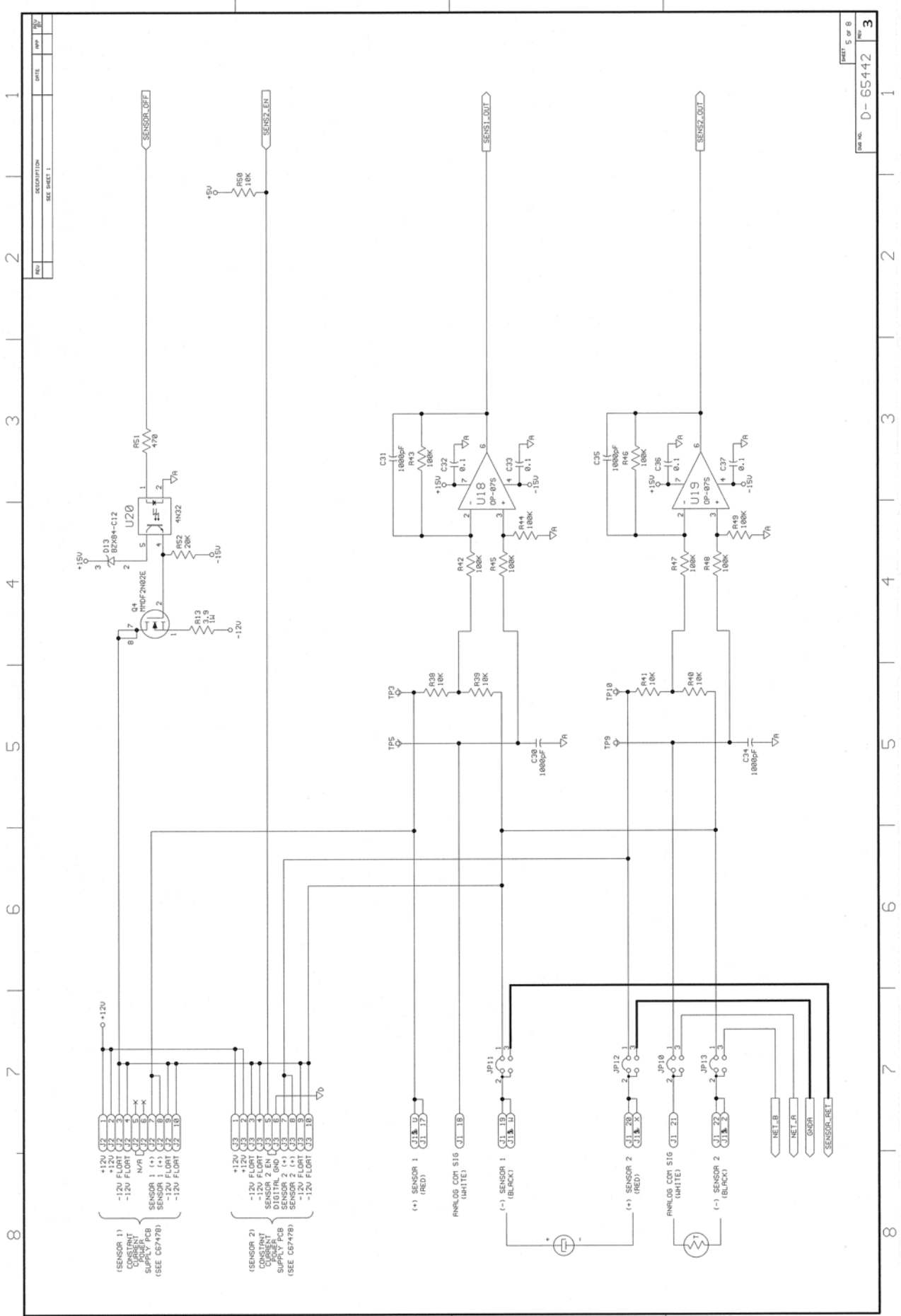

1 2 3 4 5 6 7 8



REV	DESCRIPTION	DATE	APP	BY
	SEE SHEET 1			

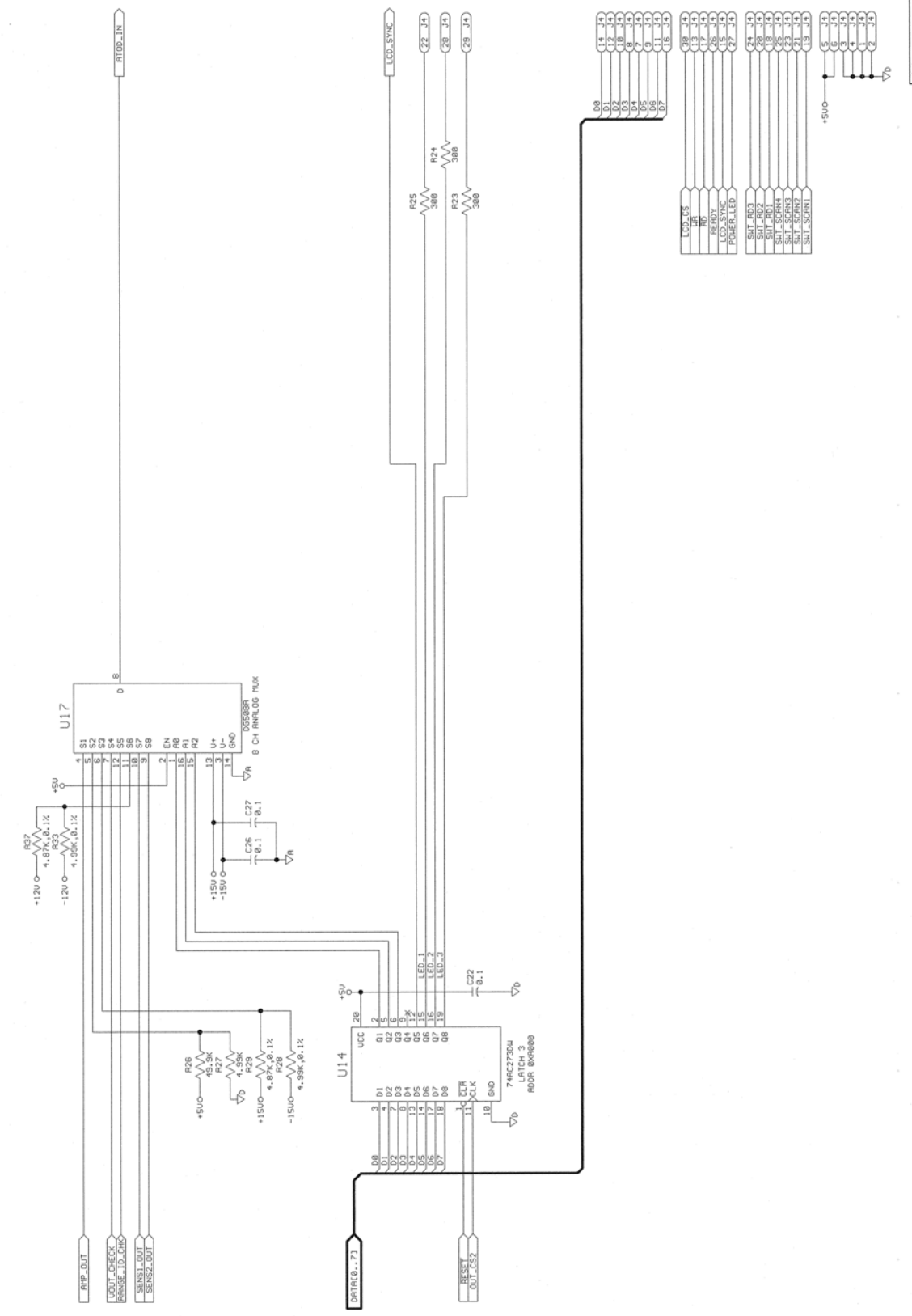





REV	DESCRIPTION	DATE	APP
	REL SHEET 1		

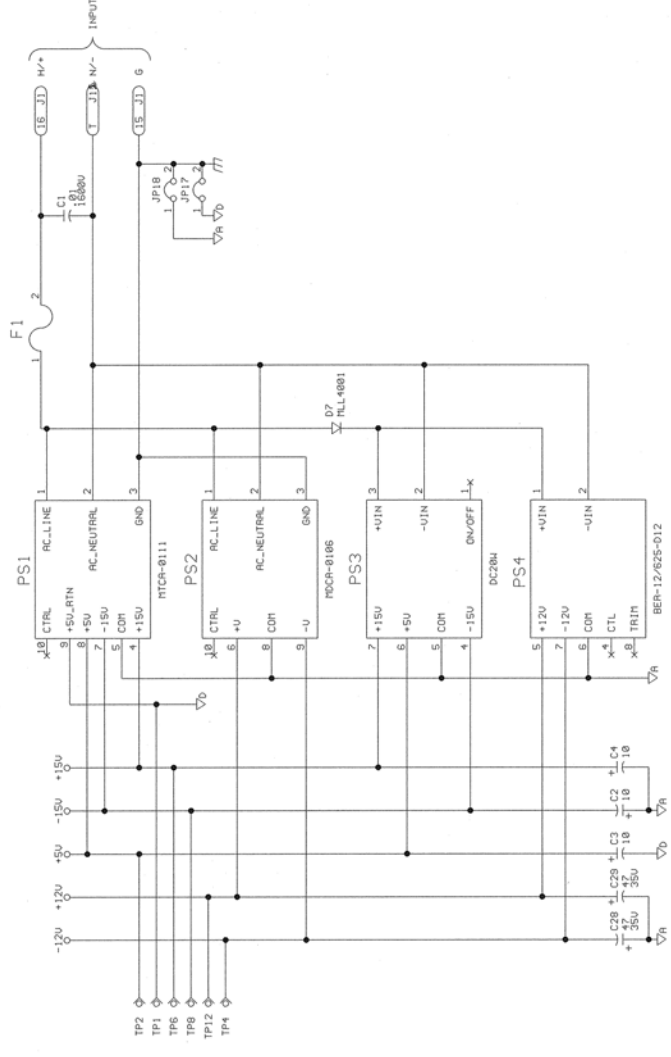
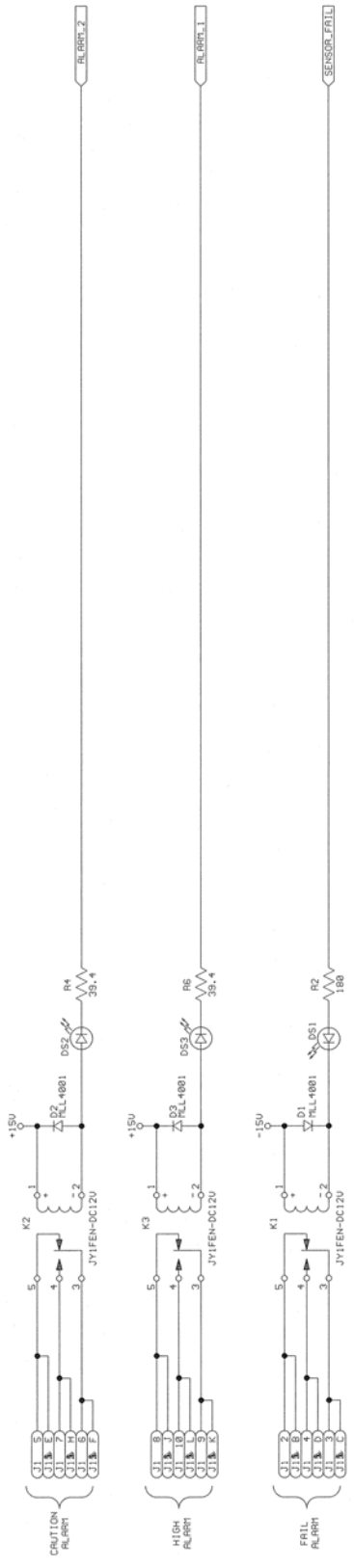



REV	DESCRIPTION	DATE
	SEE SHEET 1	

THIS SECTION USED FOR MODEL 3220

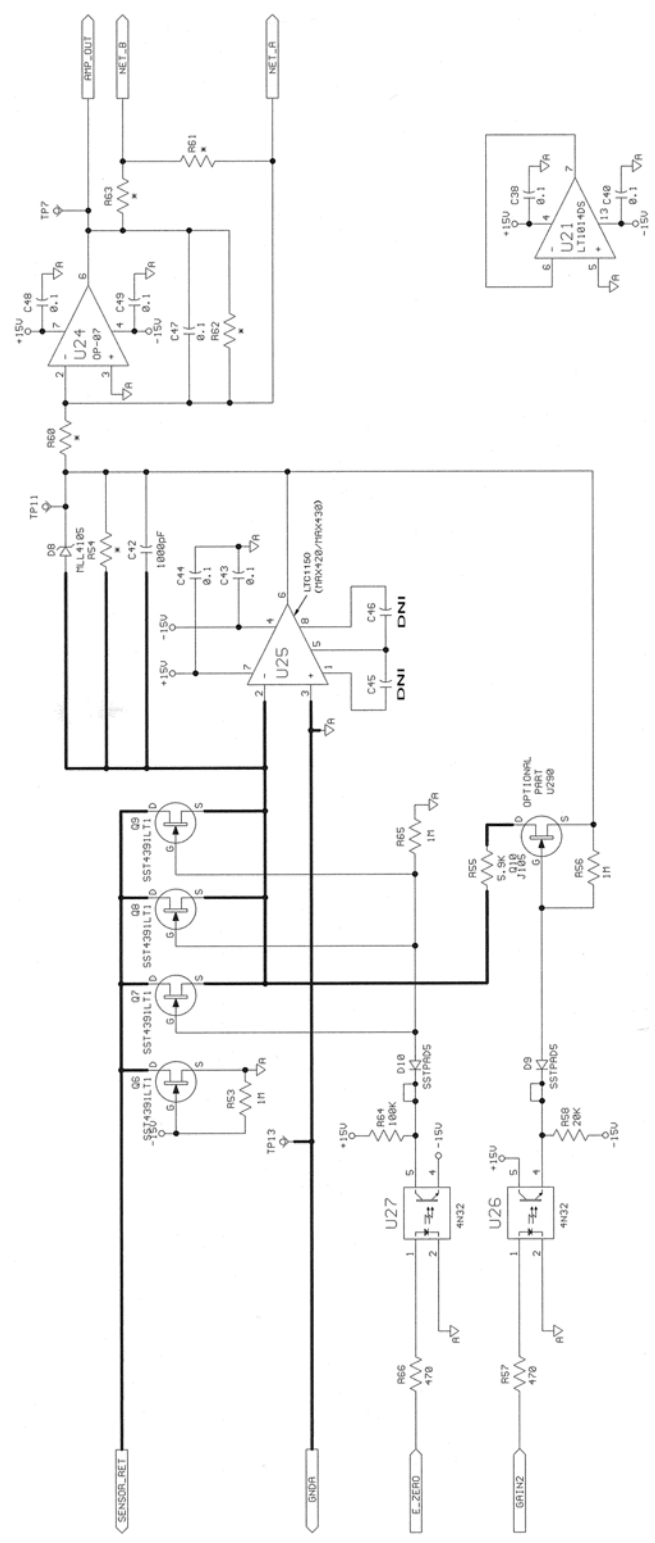

SENSOR TYPE	R60	R61	R62	R63	R64	UPLUE	P/N
B1	5.0K	10K	10K	499	5.0K	1.5K	T385
B1	49.9K	200K	10K	4.99K	5.0K	1.5K	T385
B1	4.99K	1.3K	11.2K	4.2	1.7K	1.5K	T385
B1	10K	10K	100K	2K	1.7K	1.5K	T385



REVISIONS

REV	DESCRIPTION	DATE	APP.	REV. BY
0	INITIAL RELEASE	10/10/12	RF	--

NOTES: UNLESS OTHERWISE SPECIFIED

1. TERMINAL BLOCKS: WIRE SIZE 24-10AWG
2. TERMINAL BLOCK: TB1: 12 (SH)  
THIS IS THE REMOTE SENSOR PROBE  
CABLE SHIELD CONNECTION.

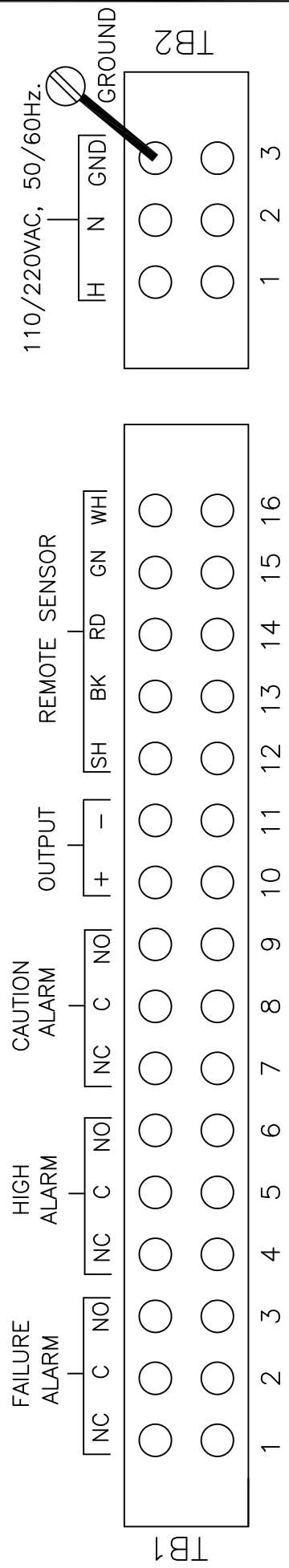

\_\_\_\_\_ CUSTOMER INTERCONNECTIONS \_\_\_\_\_

ITEM	QTY	PART NO.	DESCRIPTION
BILL OF MATERIAL			
DO NOT SCALE DWG.			
UNLESS OTHERWISE SPECIFIED DIMENSIONS ARE IN INCHES			
TOLERANCE : ANGULAR ±1/2°			
X     = ±.1			
XX    = ±.02			
XXX   = ±.005			
SIGNATURES		DATE	TITLE
S/		10/09/12	INTERCONNECTION DIAGRAM
N/	DRAFT: RF		MODEL 3220B
P/	CHK:		SINGLE CH. 02 ANALYZER
I/	A89908		
F/	ENGR: RF		
O/	C.O.: 151955		
REFERENCE	CAD I.D. A89908-0	MATL. ---	DWG NO. A- 89908
			SCALE ---
			SIM ---
			SHEET 1 OF 1
			REV

THIS DRAWING IS THE PROPERTY OF TELEDYNE INSTRUMENTS AND CONTAINS CONFIDENTIAL INFORMATION. IT IS NOT TO BE COPIED, REPRODUCED OR USED WITHOUT WRITTEN PERMISSION.



**TELEDYNE**  
Analytical Instruments  
A Business Unit of Teledyne Instruments, Inc  
City of Industry, California, 91748, USA



NOTES: UNLESS OTHERWISE SPECIFIED.

1. "SH" ON THE INTERCONNECTION DRAWING A89908 IS SHIELD GROUND CONNECTION FOR THE REMOTE SENSOR PROBE TERMINAL #12.

POWER IN  
110/220 VAC  
50/60 Hz.  
HUB 1/2" FNPT

ALARM CONN.  
FAILURE, HIGH  
AND CAUTION ALARMS  
HUB, 1/2" FNPT

SIGNAL OUT 0-10 VDC OR 4-20 mA

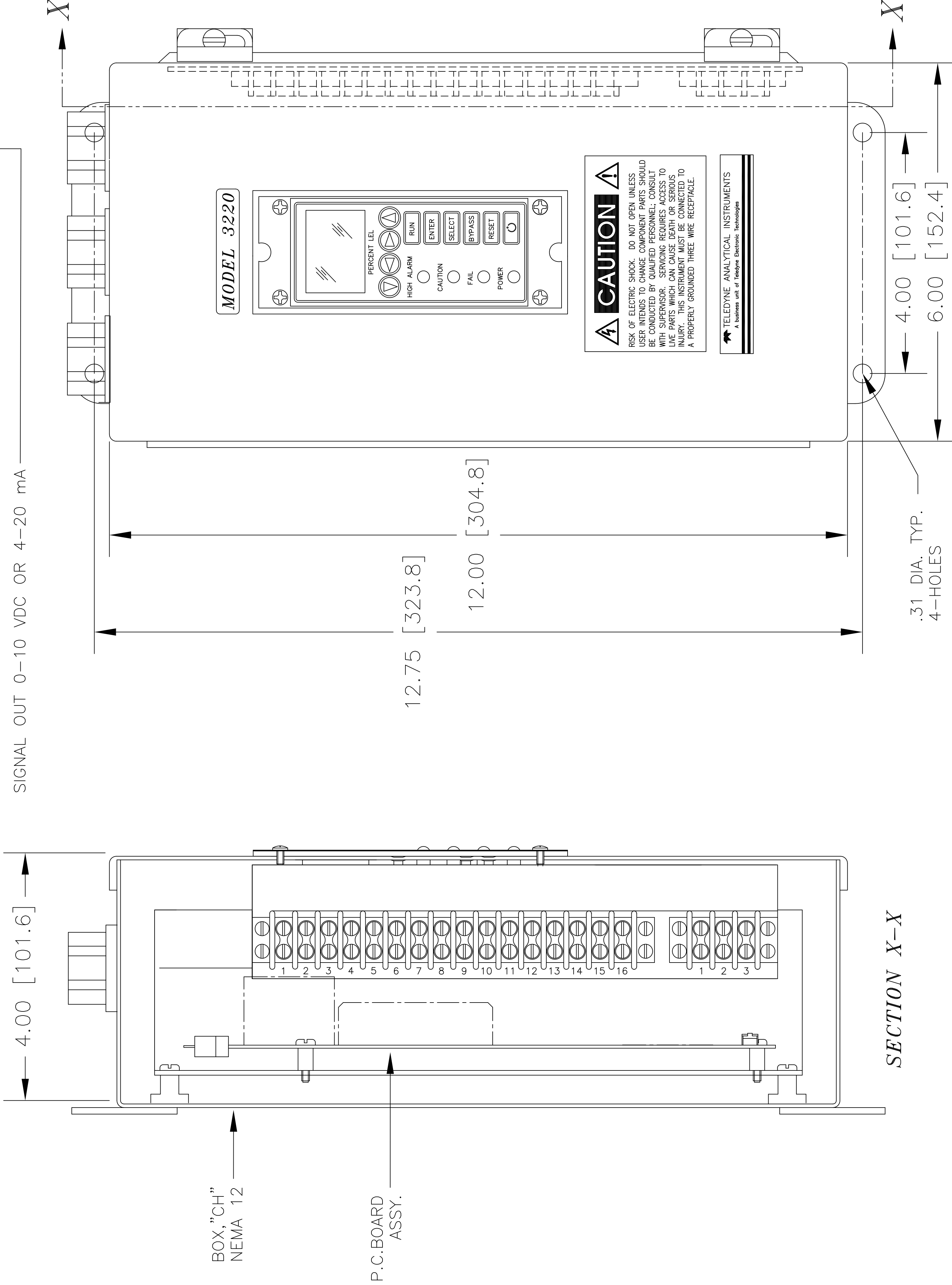

REV	DESCRIPTION	DATE	APP.	REV.
0	Initial Release	10/10/12	RF	--

REVISIONS

ITEM	QTY	PART NO.	DESCRIPTION
BILL OF MATERIAL			
DO NOT SCALE DWG			
TOLERANCE UNLESS OTHERWISE SPECIFIED: ANGULAR ±1/2°			
LINEAR ±.XX = ±.02 ±.XXX = ±.010			
SIGNATURES		DATE	TITLE
DRET: RF		09/07/12	MODEL 3220B
CHK: A89908			SINGLE CHANNEL, WALL
APPRE: D/			MOUNT, OUTLINE DIAGRAM
ENGR: RF			
C.O. 151955			
REFERENCE	CAD ID	D89917-0	

THE DRAWING IS THE PROPERTY OF TELEDYNE INSTRUMENTS AND CONTAINS CONFIDENTIAL INFORMATION. IT IS NOT TO BE COPIED, REPRODUCED OR USED WITHOUT WRITTEN PERMISSION.			
TELEDYNE INSTRUMENTS Analytical Instruments A Teledyne Technologies Company CITY OF INDUSTRY, CALIFORNIA 91748			
SCALE	4:1	SIM	D75655
SHEET	1 OF 1	REV	1
DWG NO.	D-89917	AS NOTED	0





NOTES: UNLESS OTHERWISE SPECIFIED.

1. ALL WIRES 22AWG OTHERWISE NOTED TO BE ON THE TOP OF TERMINALS (NON-NUMBER, NON-NUMBERED CUSTOMER SIDE).

2. THE BELOW TEXT ABOVE THE TERMINALS IS FOR REF. ONLY. SEE CUSTOMER INTERCONNECTION DRAWING: A89908

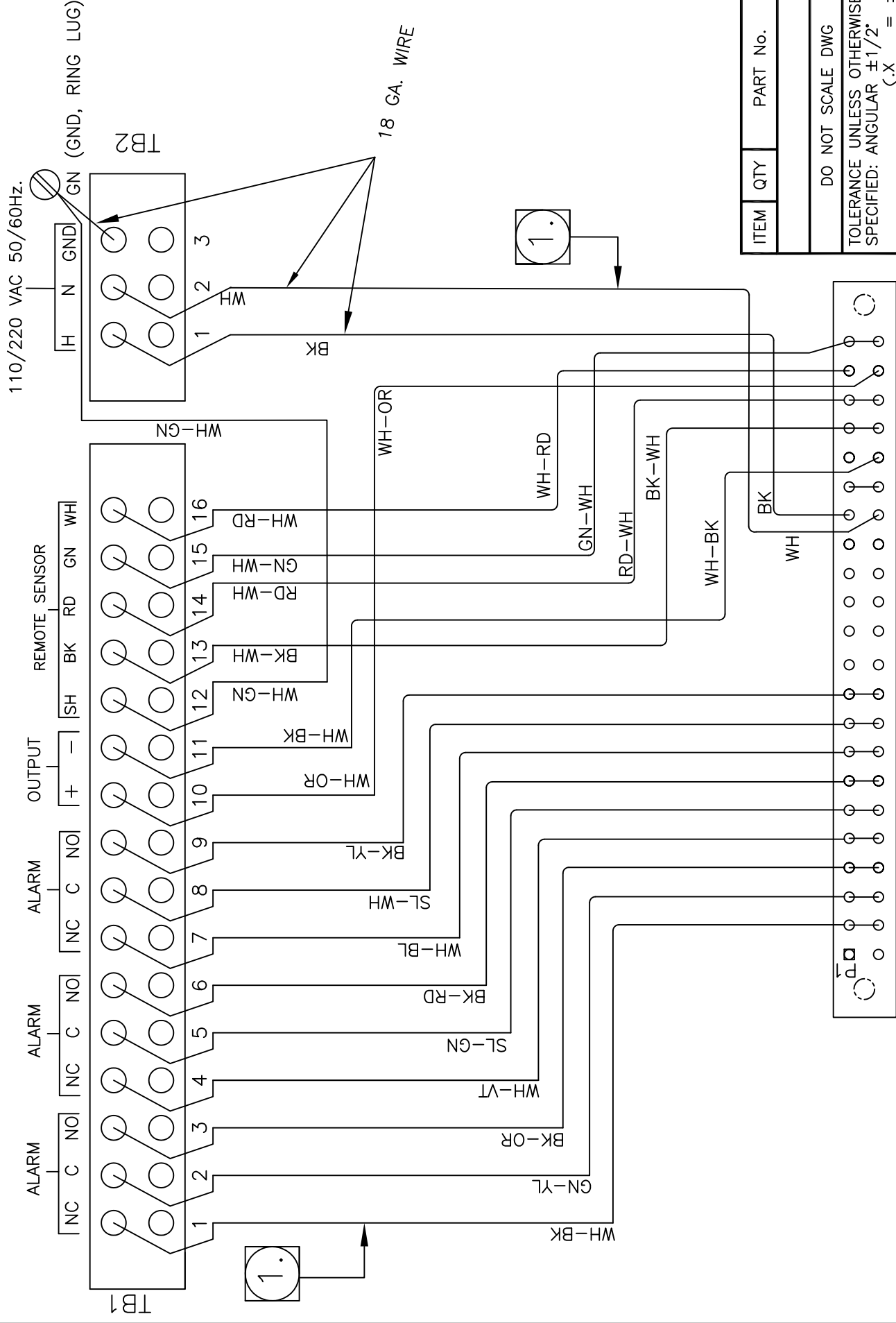

REVISIONS

REV	DESCRIPTION	DATE	APP.	REV. BY
0	Initial Release	10/10/12	RF	--
1	UPDATE WIRING COLORS	10/17/12	RF	RF
2	UPDATE WIRING	11/12/12	RF	RF

ITEM	QTY	PART No.	DESCRIPTION
BILL OF MATERIAL			
DO NOT SCALE DWG			
TOLERANCE UNLESS OTHERWISE SPECIFIED: ANGULAR ±1/2°			
LINEAR { .X = ±.1 .XX = ±.02 .XXX = ±.010			
SIGNATURES		DATE	TITLE
DRFT: RF		10/09/12	WIRING DIAGRAM
CHK:			MODEL 3220B
APPR:			SINGLE CHANNEL O2 ANALYZER
ENGR: RF			SHEET 1 OF 1
C.O.: 151955			REV
CAD I.D. B89907-2			2
REFERENCE			DWG NO. B-89907
			MATL. ---
			SCALE ---
			SIM ---

THIS DRAWING IS THE PROPERTY OF TELEDYNE INSTRUMENTS AND CONTAINS CONFIDENTIAL INFORMATION. IT IS NOT TO BE COPIED, REPRODUCED OR USED WITHOUT WRITTEN PERMISSION.

**TELEDYNE INSTRUMENTS**  
Analytical Instruments  
A Teledyne Technologies Company  
City of Industry, California, 91748, USA