

INSTRUCTION, OPERATING AND MAINTENANCE MANUAL FOR

SERIES 4060



P/N M76417
DATE 05/07/15



DANGER



Toxic and/or flammable gases or liquids may be present in this monitoring system. Personal protective equipment may be required when servicing this instrument. Hazardous voltages exist on certain components internally which may persist for a time even after the power is turned off and disconnected. Only authorized personnel should conduct maintenance and/or servicing. Before conducting any maintenance or servicing, consult with authorized supervisor/manager.

Copyright © 2015 Teledyne Analytical Instruments

All Rights Reserved. No part of this manual may be reproduced, transmitted, transcribed, stored in a retrieval system, or translated into any other language or computer language in whole or in part, in any form or by any means, whether it be electronic, mechanical, magnetic, optical, manual, or otherwise, without the prior written consent of Teledyne Analytical Instruments, 16830 Chestnut Street, City of Industry, CA 91748.

Warranty

This equipment is sold subject to the mutual agreement that it is warranted by us free from defects of material and of construction, and that our liability shall be limited to replacing or repairing at our factory (without charge, except for transportation), or at customer plant at our option, any material or construction in which defects become apparent within one year from the date of shipment, except in cases where quotations or acknowledgements provide for a shorter period. Components manufactured by others bear the warranty of their manufacturer. This warranty does not cover defects caused by wear, accident, misuse, neglect or repairs other than those performed by Teledyne or an authorized service center. We assume no liability for direct or indirect damages of any kind and the purchaser by the acceptance of the equipment will assume all liability for any damage which may result from its use or misuse.

We reserve the right to employ any suitable material in the manufacture of our apparatus, and to make any alterations in the dimensions, shape or weight of any parts, in so far as such alterations do not adversely affect our warranty.

Important Notice

This instrument provides measurement readings to its user, and serves as a tool by which valuable data can be gathered. The information provided by the instrument may assist the user in eliminating potential hazards caused by his process; however, it is essential that all personnel involved in the use of the instrument or its interface be properly trained in the process being measured, as well as all instrumentation related to it.

The safety of personnel is ultimately the responsibility of those who control process conditions. While this instrument may be able to provide early warning of imminent danger, it has no control over process conditions, and it can be misused. In particular, any alarm or control systems installed must be tested and understood, both as to how they operate and as to how they can be defeated. Any safeguards required such as locks, labels, or redundancy, must be provided by the user or specifically requested of Teledyne at the time the order is placed.

Therefore, the purchaser must be aware of the hazardous process conditions. The purchaser is responsible for the training of personnel, for providing hazard warning methods and instrumentation per the appropriate standards, and for ensuring that hazard warning devices and instrumentation are maintained and operated properly.

Teledyne Analytical Instruments, the manufacturer of this instrument, cannot accept responsibility for conditions beyond its knowledge and control. No statement expressed or implied by this document or any information disseminated by the manufacturer or its agents, is to be construed as a warranty of adequate safety control under the user's process conditions.

Safety Messages

Your safety and the safety of others is very important. We have provided many important safety messages in this manual. Please read these messages carefully.

A safety message alerts you to potential hazards that could hurt you or others. Each safety message is associated with a safety alert symbol. These symbols are found in the manual and inside the instrument. The definition of these symbols is described below:



GENERAL WARNING/CAUTION: Refer to the instructions for details on the specific danger. These cautions warn of specific procedures which if not followed could cause bodily Injury and/or damage the instrument.



CAUTION: HOT SURFACE WARNING: This warning is specific to heated components within the instrument. Failure to heed the warning could result in serious burns to skin and underlying tissue.



WARNING: ELECTRICAL SHOCK HAZARD: Dangerous voltages appear within this instrument. This warning is specific to an electrical hazard existing at or nearby the component or procedure under discussion. Failure to heed this warning could result in injury and/or death from electrocution.



Technician Symbol: All operations marked with this symbol are to be performed by qualified maintenance personnel only.

No
Symbol



NOTE: Additional information and comments regarding a specific component or procedure are highlighted in the form of a note.

STAND-BY: This symbol indicates that the instrument is on Stand-by but circuits are active.

CAUTION: THE ANALYZER SHOULD ONLY BE USED FOR THE PURPOSE AND IN THE MANNER DESCRIBED IN THIS MANUAL.



IF YOU USE THE ANALYZER IN A MANNER OTHER THAN THAT FOR WHICH IT WAS INTENDED, UNPREDICTABLE BEHAVIOR COULD RESULT POSSIBLY ACCOMPANIED WITH HAZARDOUS CONSEQUENCES.

This manual provides information designed to guide you through the installation, calibration and operation of your new analyzer. Please read this manual and keep it available.

Occasionally, some instruments are customized for a particular application or features and/or options added per customer requests. Please check the front of this manual for any additional information in the form of an Addendum which discusses specific information, procedures, cautions and warnings that may be specific to your instrument.

Manuals do get misplaced. Additional manuals can be obtained from Teledyne at the address given in the Appendix. Some of our manuals are available in electronic form via the internet. Please visit our website at: www.teledyne-ai.com.

Additional Safety Information

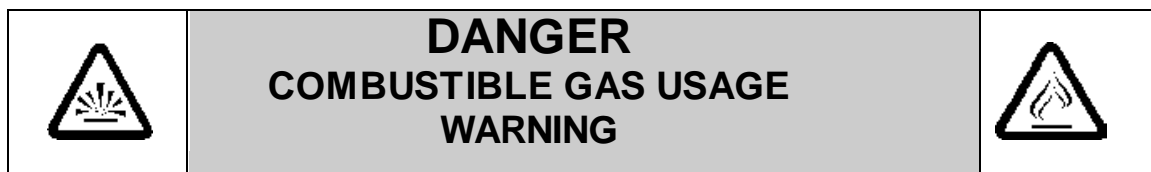

This is a general purpose instrument designed for use in a non-hazardous area. It is the customer's responsibility to ensure safety especially when combustible gases are being analyzed since the potential of gas leaks always exist.

The customer should ensure that the principles of operating of this equipment are well understood by the user. Misuse of this product in any manner, tampering with its components, or unauthorized substitution of any component may adversely affect the safety of this instrument.

Since the use of this instrument is beyond the control of Teledyne, no responsibility by Teledyne, its affiliates, and agents for damage or injury from misuse or neglect of this equipment is implied or assumed.



WARNING: *HYDROGEN GAS IS USED IN THIS INSTRUMENT AS A FUEL. HYDROGEN IS EXTREMELY FLAMMABLE. EXTREME CARE MUST BE USED WHEN WORKING AROUND GAS MIXTURES CONTAINING FLAMMABLE GASES.*

A successful leak check was performed at T/Al on the sample system of this instrument prior to calibration, testing and shipping. Ensure that there are no leaks in the fuel supply lines before applying power to the system.

Always purge the entire system before performing any maintenance and always leak check the system after removing any tubing or fittings on the sample system. See the procedures for purging and leak checking this instrument on the following pages.

If toxic gases or other hazardous materials are introduced into the sample system, the same precautions regarding leak checking and purging apply to the sample lines and sample supply or delivery lines.

WARNING:

ELECTRICAL SHOCK HAZARD. WITH THE EXCEPTION OF OPENING THE DOOR AND ADJUSTING THE PRESSURE REGULATORS, FLOW CONTROLLER, OR OBSERVING THE PRESSURE GAUGES AND THE FLOWMETER, ONLY AUTHORIZED AND SUITABLY TRAINED PERSONNEL SHOULD PERFORM WORK INSIDE OF THE INSTRUMENT. COMPONENTS WITHIN THE COVER ON THE INSIDE OF THE DOOR, INSIDE THE ISOTHERMAL CHAMBER (SAMPLE SYSTEM), AND ON THE ELECTROMETER-AMPLIFIER PC BOARD CONTAIN DANGEROUSLY HIGH VOLTAGE SUFFICIENT TO CAUSE SERIOUS INJURY OR DEATH.

There are the following three types of inaccessible shock hazards within the Analyzer:

- 1. Line voltages and line related voltages such as 115 VAC which exists within the 230 VAC versions as well. These voltages stop when the Analyzer is turned off and the mains (line) cord is removed from the instrument.*
- 2. The sensor anode supply voltage (approximately 250 VDC). This voltage exists on the Flame Guard, anode power supply, PCB, the motherboard, and the anode/igniter terminals on the sensor. THIS VOLTAGE WILL REMAIN HAZARDOUS FOR MANY MINUTES AFTER THE ANALYZER HAS BEEN TURNED OFF!*



3. *External hazardous voltages which may be connected to the Analyzer alarm relay connections.*

Procedure for Removal of Internal Inaccessible Shock Hazards



CAUTION: SERVICING OR MAINTENANCE OF THE ANALYZER SHOULD ONLY BE DONE BY SUITABLE TRAINED PERSONNEL. TO AVOID THESE INACCESSIBLE HAZARDOUS VOLTAGES WHEN SERVICING THE SERIES 4060, PERFORM EACH OF THE FOLLOWING STEPS, IN THE ORDER GIVEN, BEFORE SERVICING BEGINS:

1. Switch off the power to the Analyzer and remove the main (line) power cord from the Analyzer.
2. Remove all external voltages from the connections to the alarm contacts.
3. Wait one minute.
4. Discharge the anode supply voltage.
 - a. Connect one end of an insulated (to 1000 VDC or more) clip lead to Analyzer chassis ground (the standoff for the upper right corner of the mother PCB).
 - b. Put one end of a 500V rated 1000 ohm resistor in the other end of the clip lead.
 - c. Check the voltage between chassis ground (the standoff for the upper right corner of the mother PCB) and the top side of R2 at PCB number B74671. It should be between -5VDC and +5VDC. If is in that range, the inaccessible hazardous voltage removal procedure is completed, if not repeat steps 4.a and 4.b.

If it is absolutely necessary to work inside the instrument with power on, use the ONE HAND RULE:

Work with one hand only.

Keep the other hand free without contacting any other object. This reduces the possibility of a ground path through the body in case of accidental contact with hazardous voltages.

WARNING: *THIS INSTRUMENT IS DESIGNED TO BE OPERATED IN A NONHAZARDOUS AREA. THE ANALYZER USES HYDROGEN GAS AND/OR OTHER COMBUSTIBLE GASES IN ITS OPERATION. THIS EQUIPMENT, IF NOT USED AND MAINTAINED PROPERLY CAN BE AN EXPLOSION HAZARD. THE ANALYZER, DEPENDING ON THE APPLICATION, MAY ALSO USE TOXIC GASES. IT IS THEREFORE, THE CUSTOMER'S RESPONSIBILITY TO ENSURE THAT PROPER TRAINING AND UNDERSTANDING OF THE PRINCIPLES OF OPERATION OF THIS EQUIPMENT ARE UNDERSTOOD BY THE USER. SINCE THE USE OF THIS INSTRUMENT IS BEYOND THE CONTROL OF TELEDYNE, NO RESPONSIBILITY BY TELEDYNE, ITS AFFILIATES AND AGENTS FOR DAMAGE OR INJURY RESULTING FROM MISUSE OR NEGLIGENCE OF THIS INSTRUMENT IS IMPLIED OR ASSUMED. MISUSE OF THIS PRODUCT IN ANY MANNER, TAMPERING WITH ITS COMPONENTS OR UNAUTHORIZED SUBSTITUTION OF ANY COMPONENT MAY ADVERSELY AFFECT THE SAFETY OF THIS INSTRUMENT.*



CAUTION: *WHEN OPERATING THIS INSTRUMENT, THE DOORS MUST BE CLOSED AND ALL COVERS SECURELY FASTENED. THE GAUGES MUST BE IN PROPER WORKING ORDER. DO NOT OVERPRESSURIZE THE SYSTEM.*



READ THIS MANUAL BEFORE OPERATING THE INSTRUMENT AND ADHERE TO ALL WARNINGS INCLUDED IN THIS MANUAL.

Table of Contents

Safety Messages	iii
Additional Safety Information	v
List of Figures	xiii
List of Tables	xiv
Introduction	15
1.1 Main Features of the Analyzer	15
1.2 Principle of Operation	16
1.3 Analyzer Description	16
1.4 Applications	18
Operational Theory	19
2.1 Introduction	19
2.2 Modes of Operation	19
2.3 Analyzer Subsystems	20
2.3.1 Sample System	20
2.3.2 Gas Flow Control System	21
2.3.3 Fuel and Blanket Air Systems	22
2.3.4 Flame Ionization Detection Cell	22
2.4 Detection Cell	24
2.4.1 Electrometer-Amplifier	25
2.4.2 Anode Power Supply	26
2.4.3 Flame Guard Circuit	26
2.4.4 Flame Ignition Circuit	26
Installation	27
3.1 Unpacking the Analyzer	27
3.2 Mounting the Analyzer	27



3.3 User Connections	28
3.3.1 Electrical Power Connections	28
3.3.2 Electronic Connections	28
3.3.2.1 Primary Input Power	29
3.3.2.2 Fuse Installation	30
3.3.2.3 50-Pin Equipment Interface Connector	30
3.3.2.4 Analog Output	30
3.3.2.5 Alarm Relays	32
3.3.2.6 Digital Remote Cal Inputs	34
3.3.2.7 Range ID Relays	35
3.3.2.8 Network I/O	35
3.3.2.9 Pin Out Table	35
3.3.2.10 RS-232 Port	36
3.3.3 Gas Connections	37
3.3.3.1 Effluent	40
3.3.3.2 Sample Bypass Vent	40
3.3.3.3 Fuel and Air Connections	40
3.3.3.4 Sample and Span Gas Connections	40
3.4 Placing the System in Operation	40
Operation	41
4.1 Equipment	41
4.2 Preliminary Power-Off Check List	42
4.3 Activating the Support Gases	43
4.3.1 Air	43
4.3.2 Carrier Gas	43
4.3.3 Span Gas	43
4.3.4 Fuel	43
4.4 Flame Ignition	43
4.4.1 Verification of the Flame Guard Circuit	44
4.4.2 Ignition and/or Flame Guard Circuit Failure	44

4.5 Sample Pump	44
4.6 Analyzer Operation	45
4.6.1 Default Parameters	46
4.6.2 Style Conventions	46
4.6.3 Navigation and Data Entry	47
4.6.3.1 Arrow Keys	47
4.6.3.2 ENTER	48
4.6.3.3 ESCAPE	48
4.6.4 Menu Structure	48
4.6.4.1 Main Menus	49
4.6.5 Span	51
4.6.6 ALT-SPAN	51
4.6.7 The Model Screen	52
4.6.8 System Self-Diagnostic Test	52
4.6.9 The Alarms Function	53
4.6.10 The Range Function	55
4.6.11 Analog Output Adjustment	56
4.6.12 Linearization	56
4.6.13 Changing Stream	56
4.6.14 Setting up an AUTO-CAL	57
4.6.15 Timing	58
4.6.16 Group Setup	59
4.6.17 Password Protection	59
4.6.18 Logging Out	62
4.6.19 Standby	63
Maintenance & Troubleshooting	65
5.1 Measuring Circuit Electrical Checks	66
5.1.1 Anode Voltage Check	66
5.1.2 Electronic Stability	67
5.1.3 Printed Circuit Board Replacement	67

5.1.4 Collector Cable	68
5.2 Temperature Control Electronic Check	68
5.3 Ignition and/or Flame Guard Circuit Checks	69
5.4 Sampling System	70
5.5 Printed Circuit Board Descriptions	70
5.5.1 Flame Guard and Anode Power Supply PCB	70
5.5.2 Electrometer-Amplifier PCB	71
Appendix	73
A.1 Specifications and Initial Settings:	73
A.2 Recommended Spare Parts List	74
A.3 Drawing List	75
Appendix B	77
B1 Addendum and Testing Results	77

List of Figures

Figure 1-1: Model 4060 Front Panel Interface17
Figure 1-2: Model 4060 Rear Panel.....17
Figure 2-1: Internal Temperature Controllers21
Figure 2-2: Typical Piping Diagram for the Model 406023
Figure 3-1: Model 4060 Rear Panel with Optional Gas Manifold....29
Figure 3-2: Equipment Interface Connector Pin Arrangement30

List of Tables

Table 3-1: Analog Output Connections	31
Table 3-2: Analog Concentration Output—Example	31
Table 3-3: Analog Range ID Output—Example	32
Table 3-4: Alarm Relay Contact Pins	33
Table 3-5: Remote Calibration Connections	34
Table 3-6: Range ID Relay Connections	35
Table 3-7: Pin out of 50 pin D-Sub Connector	36
Table 3-8: Commands via RS-232 Input.....	37
Table 3-9: Required RS-232 Options	37

Introduction

Teledyne Analytical Instruments Series 4060, Trace Aromatic Hydrocarbon Analyzer, is a versatile instrument designed to measure the quantity of aromatic hydrocarbons, primarily benzene, present in a positive pressure sample gas. The analyzer is a microprocessor controlled digital instrument based on Teledyne's highly successful Model 402R series analog Total Hydrocarbon Analyzer, coupled with a gas separation column and a switching valve. The basic analyzer allows for the measurement of benzene in the low ppb range. The Analyzer also allows the diagnostic capability to look for other aromatics, like toluene, ethyl benzene and xylenes. Other versions of Series 4060 allowing for dual measurements are also available. Contact the factory for further detail.

1.1 Main Features of the Analyzer

The Analyzer is sophisticated yet simple to use. A dual display on the front panel prompts and informs the operator during all phases of operation. The main features of the analyzer include:

- Easy-to-use front panel interface that includes a red 5-digit LED display and a vacuum fluorescent display (VFD), driven by microprocessor electronics.
- High resolution, accurate readings of concentration.
- Versatile analysis with three user-definable analysis ranges.
- Microprocessor based electronics: 8-bit CMOS microprocessor with 32 kB RAM and 128 kB ROM.
- Auto ranging allows analyzer to automatically select the proper preset range for a given measurement. Manual override allows the user to lock onto a specific range of interest.
- Two adjustable concentration alarms and a system failure alarm.

- Extensive self-diagnostic testing at startup and on demand with continuous power supply monitoring.
- RS-232 serial digital port for use with a computer or other digital communication device.
- Analog outputs for concentration and range identification (0-1 VDC standard and isolated 4-20 mA dc).
- Superior Accuracy

1.2 Principle of Operation

The analyzer uses a gas separation column to separate the component of interest, like benzene, from the other hydrocarbons in the sample gas. Using a carrier gas and a microprocessor actuated switching valve, the eluted gas is analyzed in Flame Ionization Detector (FID) and the column is back flushed to accept the fresh sample in the next cycle. More information is provided in Section 2.1 *Introduction*, under *Operational Theory*. The electrical output of the electrometer-amplifier is directly proportional to the concentrations of the ionizable hydrocarbons present over the ranges of interest.

1.3 Analyzer Description

The standard analyzer is a rack mountable instrument designed to fit into a standard 19" instrument rack. The front interface panel is mounted on a door which, when opened, allows convenient access to the Analyzer electronics. The entire front panel can slide out of the chassis to provide greater access to the electronics and to the sample system. Gas pressure and flow controls are mounted on the front panel adjacent to the LED and VFD displays and user interface.

At the rear of the instrument are ports for the introduction of air, fuel, zero, span, and sample gas. A single 50-pin user-interface cable connector contains input/output and alarm signals available to the user. An RS-232 port is also available at the rear panel for connection to a remote computer or other digital communication device. The Analyzer is set up for either 120 VAC 60 Hz or 230 50/60 Hz operation depending on the customer's requirements. The appropriate power cord for your unit has been shipped with this instrument.

Figure 1-1 shows the Model 4060 front interface while Figure 1-2 shows the rear panel including the user connections.

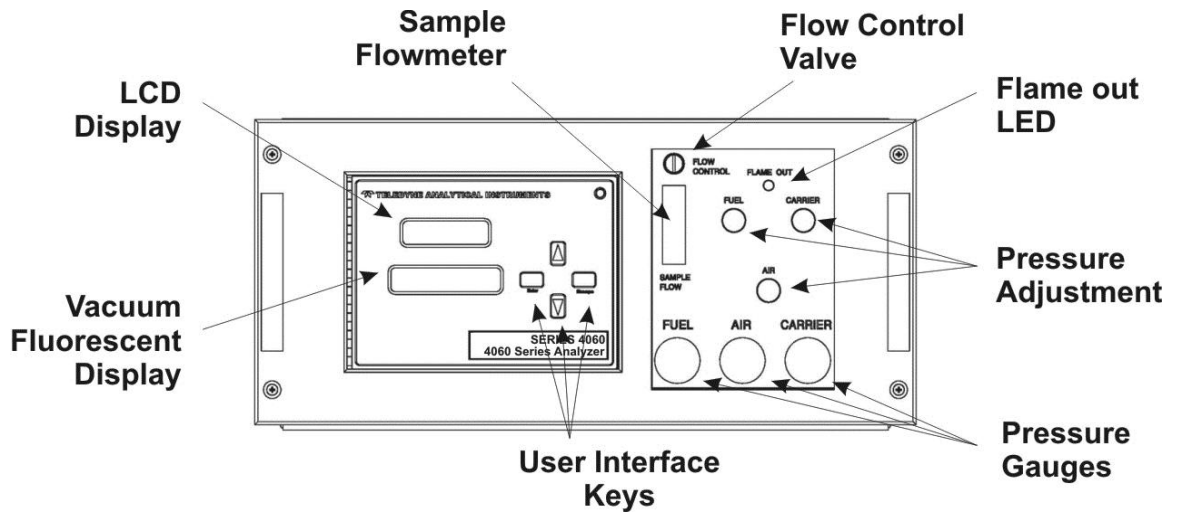

Figure 1-1: Model 4060 Front Panel Interface

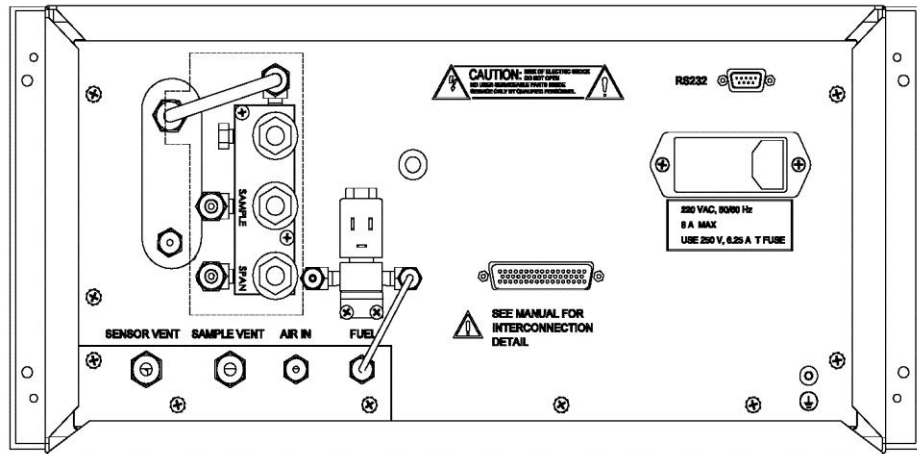

Figure 1-2: Model 4060 Rear Panel

1.4 Applications

- Monitoring the benzene concentration of carbon dioxide gas for use in the beverage industry.
- Monitoring aromatic contamination in air liquefaction and other gas production processes.
- Gas purity certification.
- Detecting trace benzene in ambient air.
- Detecting atmospheric pollutants.

Operational Theory

2.1 Introduction

Series 4060 Analyzer for Benzene uses a FID detector and a Gas Chromatograph (GC) Column. Using a carrier gas and a microprocessor actuated switching valve, a fixed volume of sample is pushed into the Column maintained at a constant temperature. The eluted gas is analyzed for benzene in a FID detector and the column is back flushed to accept the fresh sample in the next cycle. Actual separating and detecting sequence may vary depending on compounds of interest in the application for which the analyzer is configured.

The Series 4060 Analyzer uses a flame ionization detector to sense benzene. The FID was selected based on the positive performance and extensive experience in the use of this detector in other Teledyne analyzers namely Model 402R and Model 4020. The FID has proven itself to be a rugged, stable, long life sensor giving years of trouble free operation in various applications. Also considering the fact that the required sensitivity of 100 ppb full scale was achieved, FID was considered a better choice over the limited life and less reliable Photo Ionization Detector.

A stainless steel packed column containing Chromosorb Diatomite was used at a constant temperature of 70 C. Using nitrogen as a carrier gas and a 5 ml sample loop, benzene elutes from the column within a few minutes. Additionally, a clear separation is observed from other aromatic hydrocarbons, namely toluene, ethyl benzene, and xylenes. The actual temperature setpoint and compound separation for your instrument may be different depending on the application. It is listed in the *Addendum and Testing Results* section of Appendix B.

2.2 Modes of Operation

The analyzer has 2 modes of operation depending on the position of the GC Sampling Valve (See Piping Diagram in Figure 2-2). They are: Sample Mode (position A) and Analysis Mode (position B).

1. Valve Position A—**Sampling Mode**

In this mode the analyzer configures the operational valve to back flush the column and charge the sample loop. The Sample Mode is programmed to continue for a 7 minute period by factory default; however, it is usually modified to match the needs of a particular process. The specific timing interval for your system is listed in the *Addendum and Testing Results* section of Appendix B. It is possible to set the Sample Mode duration up to 25 minutes.

2. Valve Position B—**Analysis Mode**

In this mode the analyzer configures the sampling valve to feed the gas in the sample loop through the column and to the detector. The eluted sample from the column is fed to the FID for the analysis of the compound of interest in the hydrocarbon stream. If configured to do so, the analyzer may read the detector for a programmed 5 second period at some point within this mode cycle to obtain a baseline reading for further calculation. This mode is usually programmed to continue until the compound of interest is fully eluted from the column. It is possible to set it up to 25 minutes.

During the Analysis Mode, a 'Peak Detect' period is programmed at which time the analyzer reads the detector output. The analyzer integrates the peak area during this time in conjunction with the baseline settings to calculate the concentration of the compound of interest. The calculation is performed at the end of the 'Peak Detector' period and the result is displayed at the end of Analysis Mode.

2.3 Analyzer Subsystems

The Model Analyzer is composed of three subsystems:

1. Sample System
2. Detector Cell
3. Electronic Signal Processing, Display and Control

2.3.1 Sample System

All components used to control the sample and supporting gases, as well as the combustion portion of the detector cell, are located inside the

analyzer chassis. They are accessible by opening the front door of the analyzer.

Adjustments are made using the appropriate control on the front panel.

The analyzer contains three separate isothermal chambers 'SAMPLE', 'FID', and 'COLUMN' that are controlled by individual PID temperature controllers. These controllers with integral readout display are visible just behind the front panel as shown in Figure 2-1.

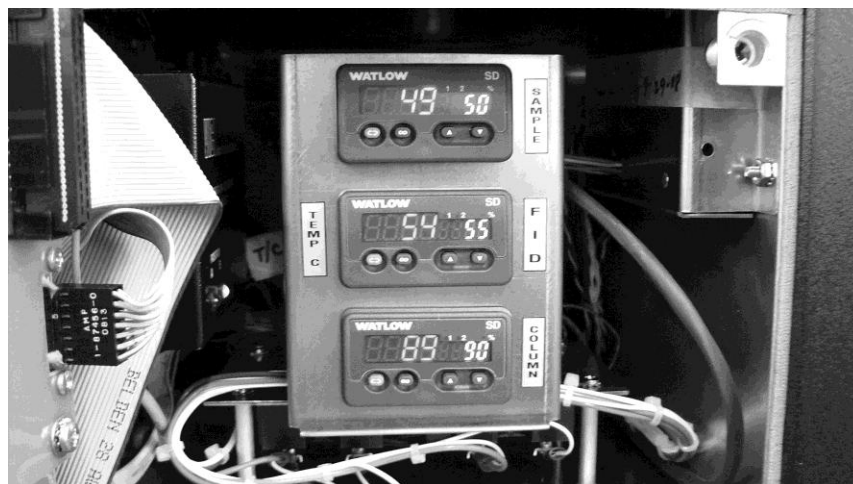

Figure 2-1: Internal Temperature Controllers

The sample chamber contains the 10-port GC switching valve and 2 sample loops. The 'FID' chamber contains the flame, pressure regulators, pressure gauges and flow restrictors used by the FID detector. The 'COLUMN' is housed in a separate 'COLUMN' enclosure and maintained at a temperature of 70° C by its PID temperature controller. The actual temperature setpoint for your instrument may be different depending on the application. It is listed in the *Addendum and Testing Results* section of Appendix B.

2.3.2 Gas Flow Control System

The analyzer is equipped with ports for the introduction of air, fuel, carrier gas, span, and sample gas. It is imperative that these gases are

supplied at constant pressures using two stage stainless steel diaphragm gas regulators. The recommended pressure range is 30 to 80 psig, however, the span gas should be supplied at a pressure of 20 psig to the restrictor fitting either on the optional autocal module or the span inlet on the rear panel.

The Piping Diagram for the standard instrument is shown in Figure 2-2. A 10-port 2-position GC sampling valve is used to control and direct gas flows including sampling, back flush, and carrier gas. The fixed volume sample loop ensures the same volume of sample injection in the column every cycle.

If your instrument is fitted with the optional auto calibration module, a separate compartment containing of a pair of solenoid valves is installed for controlling the introduction of sample or span gas to the detector. Calibration can be performed automatically on a programmed schedule or manually using the front panel interface.

2.3.3 Fuel and Blanket Air Systems

Stable flow is achieved by maintaining a constant pressure across restrictors upstream from the cell. Each system incorporates an adjustable pressure regulator, pressure gauge, and restrictor. A flame out light is included to indicate when the flame fails. A fuel shut-off solenoid valve, mounted on the line that supplies fuel, stops the fuel flow in case of flame failure. This valve is located in line with the fuel port.

2.3.4 Flame Ionization Detection Cell

The carrier gas containing sample and fuel are combined within a tee fitting located in the isothermal chamber. The mixed gas is emitted from a burner within the sensor assembly. Blanket air is introduced into the sensor (or cell) by means of a separate fitting that is located in the base section of the assembly. The upper half of the assembly houses the anode-igniter, collector, and flame guard thermistor.

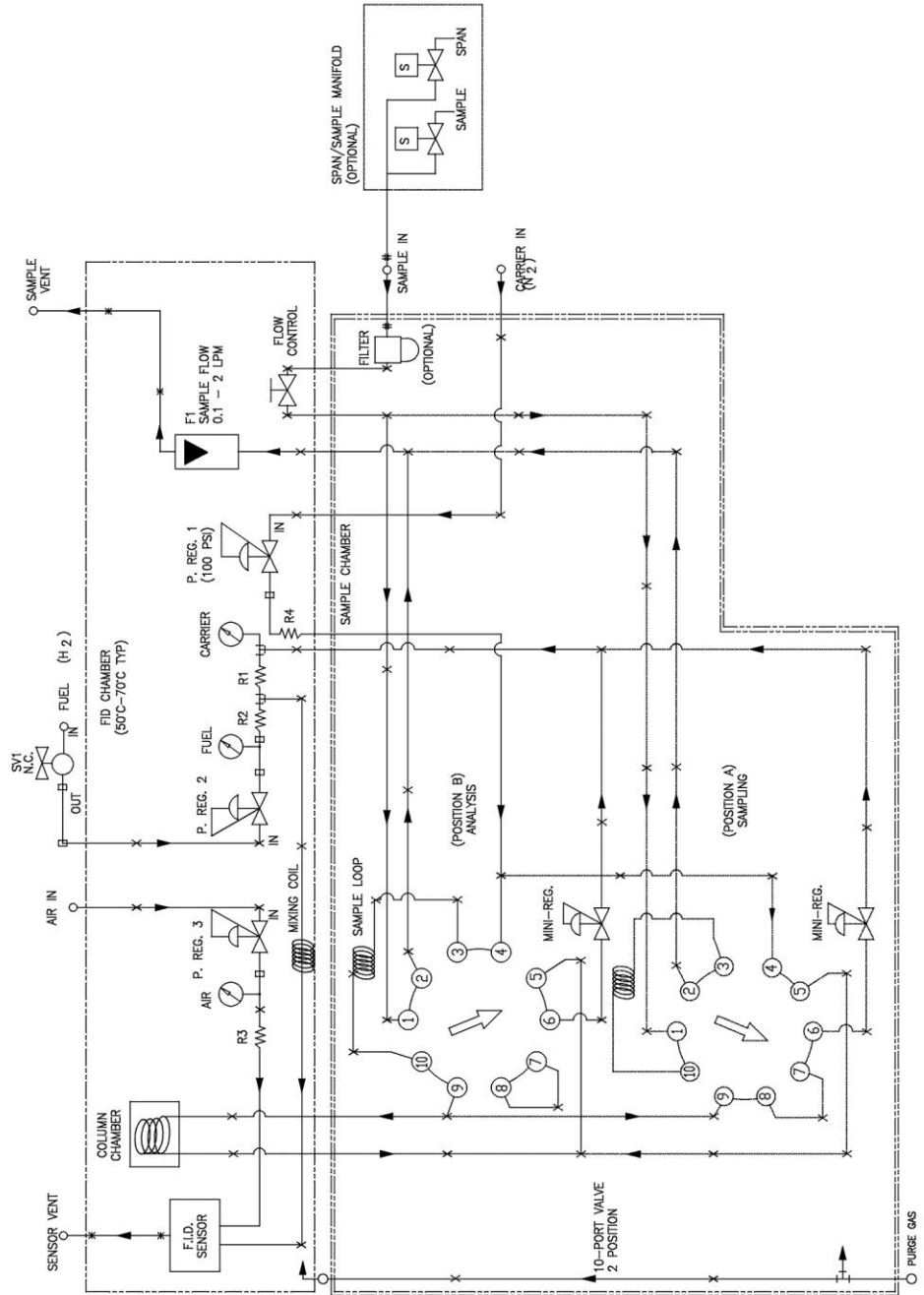

Figure 2-2: Typical Piping Diagram for the Model 4060

2.4 Detection Cell

The upper section of the stainless steel flame ionization cell houses the cylindrical collector electrode, the high voltage (+260 VDC) anode-igniter coil, and the sensing thermistor of the flame guard circuit (see cell cross-section in Figure 2-3).



WARNING: DANGEROUS HIGH VOLTAGE EXISTS AT THE ANODE IGNITER COIL (+260 VDC). DO NOT ATTEMPT TO DISCONNECT THE IGNITER COIL CABLE OR DISASSEMBLE ANY OF THE FLAME IONIZATION CELL COMPONENTS WITHOUT TURNING OFF THE POWER AND DISCONNECTING THE POWER CORD.

The collector is interconnected with the electrometer-amplifier PC board by a coaxial cable. Although the cable and fittings are intended for coaxial service, the cable is actually being used as a shielded single-conductor connection.

The anode-igniter, as its name implies, serves two functions. When relay K2 at PCB part number B74671 is energized, the coil becomes an electrical heating element that glows red-hot and ignites the hydrogen fuel. When relay K2 at B74671 is de-energized, the coil is connected to the +260 volt DC terminal of the anode-flame guard power supply PC board. In this configuration, the necessary potential difference is established between the coil (anode) and collector to promote ionization of the burned hydrocarbons. The coil functions as the high voltage anode in all three-range positions of the selector switch.

The thermistor acts as the sensor in the flame guard circuit. Its ambient temperature resistance is in the 100 K ohms region. When the flame is ignited, its resistance is reduced by a factor of 100. The thermistor is coupled to a semiconductor control circuit on the anode-flame guard power supply PC board, which will be described in a following section.

The cell electrodes of both the anode-igniter and flame guard thermistor are connected to the electronics chassis by means of a plug-in cable.

The electrode section of the cell may be removed for inspection by turning off the power, disconnecting the electrode lead plug, and removing the screws, which retain the electrode assembly in the sensor body.

2.4.1 Electrometer-Amplifier

The collector cable is coupled directly to a coaxial fitting located on the electrometer-amplifier PC board. The PC board is located on the side panel next to but outside of the isothermal chamber. It consists of an electrometer amplifier and an operational amplifier. This circuit is a very high-gain, current-to-voltage converter circuit, having an input impedance measuring in the billions of ohms. It is static sensitive and highly susceptible to contamination. Special care must be taken in handling this PC board.

Refer to Section 5.5.2: *Electrometer-Amplifier PC Board* for more information concerning the electrometer-amplifier and the other printed circuits that follow.

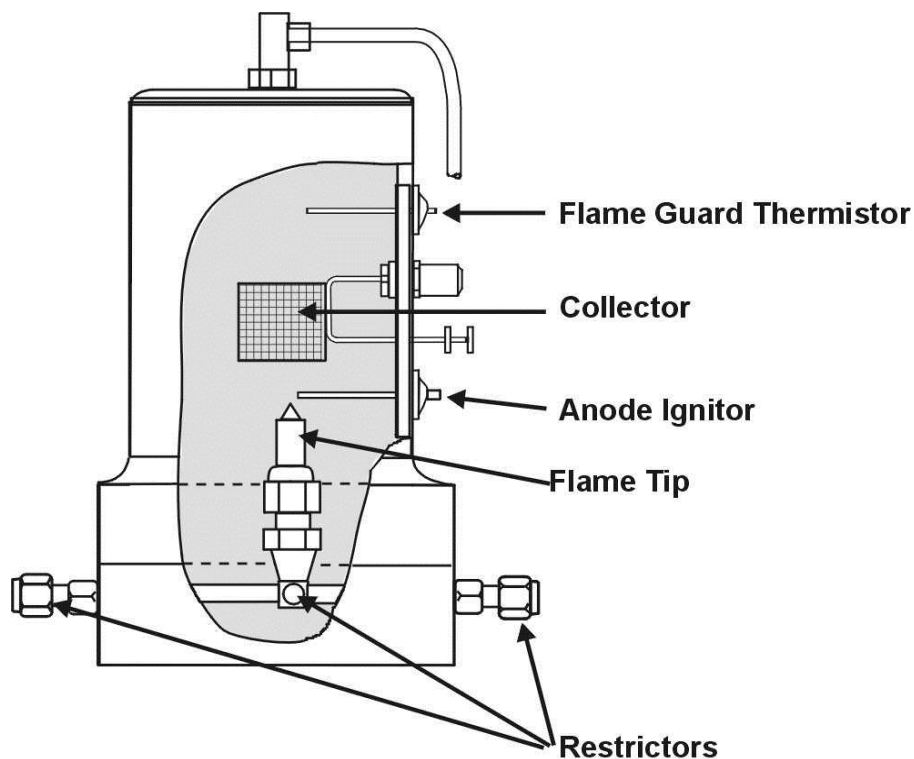

Figure 2-3: Flame Ionization Cell

2.4.2 Anode Power Supply

The high voltage anode power supply components are mounted on the anode power supply printed circuit board. High voltage regulation is achieved through the use of series-connected zener diodes. The simplicity of this circuit's design can be attributed to the extremely low current demand of the anode circuit. The positive output voltage is nominally 125 volts. Output tolerance is ± 10 volts from the specified 125 volts.

2.4.3 Flame Guard Circuit

A thermistor-controlled, transistorized switching circuit is employed to operate a relay in the event of a flame-out condition. A panel indicator light and fuel shut-off solenoid valve are operated by the relay to alarm personnel that a flame-out condition has occurred. The fuel shut-off solenoid valve stops the hydrogen flow.

2.4.4 Flame Ignition Circuit

The flame ignition circuit includes the anode-igniter electrode (in the detector cell), a transformer, and processor controlled relay. The circuit is automatically energized when the FID cools due to lack of flame.

If automatic ignition fails five times, there will be a message that reports this, and the flame can be manually ignited by pressing simultaneously the Up and Down key.

Installation

Installation of the Series 4060 Analyzer includes:

1. Unpacking
2. Mounting
3. Gas connections
4. Electrical connections
5. Testing the system.

3.1 Unpacking the Analyzer

Although the analyzer is shipped with all the materials you need to install and prepare the system for operation. Carefully unpack the Analyzer and inspect it for damage. Immediately report any damage or shortages to the shipping agent.

3.2 Mounting the Analyzer

The Series 4060 is a general-purpose analyzer and as such is designed with (non-sealed) enclosures. It must be installed in an area where the ambient temperature is not permitted to drop below 32°F nor rise above 100°F. In areas outside these temperatures, auxiliary heating/cooling must be supplied. The 4060 enclosure is oil and dust resistant and although it is designed to resist moisture, it should NOT be considered completely watertight. Mounting to walls or racks must be made securely. Avoid locations that are subject to extreme vibration and sway.

Sufficient space must be provided around the analyzer to accommodate the necessary electrical conduit and plumbing connections. The front panel must be allowed to be pulled out for possible service access to all components of the enclosure. Refer to the system/analyzer outline drawings for dimensions.

Note: To completely slide the analyzer out of the enclosure, pull Analyzer out until it stops, then push down on the release

levers found almost at the end of the sliders, both sides at the same time.

Regardless of configuration, the analyzer/system must be installed on a level surface with sufficient space allocated on either side for personnel and test equipment access. Subject to the foregoing, the Analyzer/system should be placed as close to the sample point as is possible.

All pertinent dimensions, connecting points, and piping details can be found in the drawings section as part of the outline, input-output, and piping diagrams. These drawings are specific to the instrument or system to which the manual applies.

3.3 User Connections

All user connections are made on the rear panel. Consult the input-output and outline diagrams in the drawing section of the manual. Not all the features displayed may be present in your system. Refer to any Addenda for additional information that may apply to your instrument.

3.3.1 Electrical Power Connections

The standard analyzer requires a supply of 100-125VAC, single-phase power. Power connections are made at the rear panel of the unit. Refer to the input-output diagram for more information. The electrical power service must include a high-quality ground wire. A high-quality ground wire is a wire that has zero potential difference when measured to the power line neutral. If you have the 220 VAC option, you will require 220 or 240 VAC, 50/60 Hz power. Check the analyzer input-output diagram, power schematic, outline, and wiring diagrams for incoming power specifications and connecting points.

CAUTION: **PRIMARY POWER TO THE SYSTEM SHOULD NOT BE SUPPLIED UNTIL ALL CUSTOMERS WIRING IS INSPECTED PROPERLY BY START-UP PERSONNEL**



3.3.2 Electronic Connections

Figure 3-1 shows the Series 4060 rear panel. There are connections for power, digital communications, and both digital and analog concentration output.

For safe connections, no uninsulated wiring should be able to come in contact with fingers, tools or clothing during normal operation.

CAUTION: USE SHIELDED CABLES. ALSO, USE PLUGS THAT PROVIDE EXCELLENT EMI/RFI PROTECTION. THE PLUG CASE MUST BE CONNECTED TO THE CABLE SHIELD, AND IT MUST BE TIGHTLY FASTENED TO THE ANALYZER WITH ITS FASTENING SCREWS. ULTIMATELY, IT IS THE INSTALLER WHO ENSURES THAT THE CONNECTIONS PROVIDE ADEQUATE EMI/RFI SHIELDING.

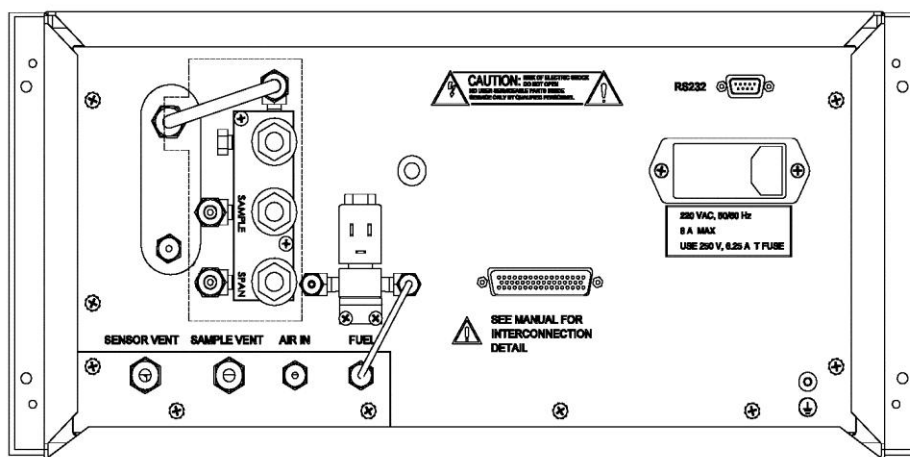

Figure 3-1: Model 4060 Rear Panel with Optional Gas Manifold

3.3.2.1 PRIMARY INPUT POWER

The power cord receptacle and fuse block are located in the same assembly. Insert the power cord into the power cord receptacle.

CAUTION: POWER IS APPLIED TO THE INSTRUMENT'S CIRCUITRY AS LONG AS THE INSTRUMENT IS CONNECTED TO THE POWER SOURCE.



The standard power supply requires 110 VAC, 50/60 Hz or 220 VAC, 50/60 Hz (optional) power.

3.3.2.2 FUSE INSTALLATION

The fuse block, at the right of the power cord receptacle, accepts US or European size fuses. A jumper replaces the fuse in whichever fuse receptacle is not used.

3.3.2.3 50-PIN EQUIPMENT INTERFACE CONNECTOR

Figure 3-2 shows the pin layout of the Equipment Interface connector. The arrangement is shown as seen when the viewer faces the rear panel of the analyzer. The pin numbers for each input/output function are given where each function is described in the paragraphs below.

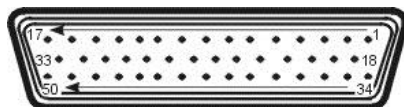

Figure 3-2: Equipment Interface Connector Pin Arrangement

3.3.2.4 ANALOG OUTPUT

There are four DC output signal pins—two pins per output. For polarity, see Table 3-1. The outputs are:

- | | |
|----------------------|--|
| 0–1 VDC % of Range: | Voltage rises linearly with increasing concentration, from 0 V at 0 concentration to 1 V at full scale. (Full scale = 100% of programmable range.) |
| 0–1 VDC Range ID: | 0.20 V = Low Range
0.5 V = Medium Range
0.80 V = High Range |
| 4–20 mA DC % Range: | Current increases linearly with concentration, from 4 mA at 0 concentration to 20 mA at full scale. (Full scale = 100% of programmable range.) |
| 4–20 mA dc Range ID: | 6.8 mA = Range 1
12.0 mA = Range 2
16.8 mA = Range 3 |

Table 3-1: Analog Output Connections

Pin	Function
3	Channel 2, + 4-20 mA, floating
4	Channel 2, - 4-20 mA, floating
5	Channel 1, + 4-20 mA, floating
6	Channel 1, - 4-20 mA, floating
8	Channel 2, 0-1 VDC
23	Channel 2, 0-1 VDC, negative ground
24	Channel 1, 0-1 VDC
7	Channel 1, negative ground

Examples:

The analog output signal has a voltage which depends on gas concentration relative to the full scale of the range. To relate the signal output to the actual concentration, it is necessary to know what range the instrument is currently on, especially when the analyzer is in the auto ranging mode.

The signal output for concentration is linear over the currently selected analysis range. For example, if the analyzer is set on a range that was defined as 0-100 ppb benzene, then the output would be as shown in Table 3-2.

To provide an indication of the range, the Range ID analog outputs are used. They generate a steady preset voltage (or current when using the current outputs) to represent a particular range. Table 3-3 gives the range ID output for each analysis range.

Table 3-2: Analog Concentration Output—Example

Ppb Benzene	Voltage Signal Output (VDC)	Current Signal Output (mA DC)
0	0.0	4.0
10	0.1	5.6
20	0.2	7.2
30	0.3	8.8

40	0.4	10.4
50	0.5	12.0
60	0.6	13.6
70	0.7	15.2
80	0.8	16.8
90	0.9	18.4
100	1.0	20.0

Table 3-3: Analog Range ID Output—Example

Range	Voltage Signal Output (VDC)	Current Signal Output (mA DC)	Application
Range 1	0.20	7.2	0–100 ppb Benzene
Range 2	0.50	12	0–1 ppm Benzene
Range 3	0.80	16.8	0–10 ppm Benzene

3.3.2.5 ALARM RELAYS

The nine alarm-circuit connector pins connect to the internal alarm relay contacts. Each set of three pins provides one set of Form C relay contacts. Each relay has both normally open and normally closed contact connections. The contact connections are shown in Table 3-4. They are capable of switching up to 3 amperes at 250 VAC into a resistive load. The connectors are:

Threshold Alarm 1:

- Can be configured as high (actuates when concentration is above threshold), or low (actuates when concentration is below threshold).
- Can be configured as failsafe or non-failsafe
- Can be configured as non-latching
- Can be configured out (defeated).

Threshold Alarm 2:

- Can be configured as high (actuates when concentration is above threshold), or low (actuates when concentration is below threshold).
- Can be configured as failsafe or non-failsafe
- Can be configured as non-latching
- Can be configured out (defeated).

System Alarm:

- Actuates when DC power supplied to circuits is unacceptable in one or more parameters. Permanently configured as failsafe and latching. Cannot be defeated.

Note: Reset by pressing the STANDBY button to remove power. Then press STANDBY again and any other button except SYSTEM to resume. Further detail can be found in Chapter 4, Section 4.6.19.

Table 3-4: Alarm Relay Contact Pins

Pin	Contact
45	Threshold Alarm 1, normally closed contact
28	Threshold Alarm 1, moving contact
46	Threshold Alarm 1, normally open contact
42	Threshold Alarm 2, normally closed contact
44	Threshold Alarm 2, moving contact
43	Threshold Alarm 2, normally open contact
36	System Alarm, normally closed contact
20	System Alarm, moving contact
37	System Alarm, normally open contact

3.3.2.6 DIGITAL REMOTE CAL INPUTS

The digital remote calibration input accepts 0 V (off) or 24 VDC (on) for remote control of calibration. (See *Remote Calibration Protocol* below.) See Table 3-5 for pin connections.

Span: Floating input. A 5–24 V input across the + and – pins puts the analyzer into the *Span* mode. Either side may be grounded at the source of the signal. A 0–1 volt across the terminals allows *Span* mode to terminate when done. A synchronous signal must open and close external span valve appropriately.

Cal Contact: This relay contact is closed while analyzer is spanning. (See *Remote Calibration Protocol* below.)

Table 3-5: Remote Calibration Connections

Pin	Function
10	+ Remote Span
12	– Remote Span
40	Cal Contact
41	Cal Contact

Remote Calibration Protocol: To properly time the Digital Remote Cal Inputs to the Model 4060 Analyzer, the customer's controller must monitor the Cal Relay Contact.

When the contact is OPEN, the analyzer is analyzing, the Remote Cal Inputs are being polled, and a span command can be sent.

When the contact is CLOSED, the analyzer is already calibrating. It will ignore your request to calibrate, and it will not remember that request.

Once a span command is sent, and acknowledged (contact closes), release it. If the command is continued until after the span is complete, the calibration will repeat and the Cal Relay Contact (CRC) will close again.

For example:

1. Test the CRC. When the CRC is open, send a span command until the CRC closes (The CRC will quickly close.)

2. When the CRC closes, remove the span command.

When CRC opens again, the span calibration is done, and the sample is being analyzed.

3.3.2.7 RANGE ID RELAYS

There are three dedicated Range ID relay contacts. They are assigned to relays in ascending order—Low range is assigned to Range 1 ID, Medium range is assigned to Range 2 ID, and High range is assigned to Range 3 ID. Table 3-6 lists the pin connections. Contacts are normally open, and they close when 4060 switches to that particular range.

Table 3-6: Range ID Relay Connections

Pin	Function
21	Range 1 ID Contact
38	Range 1 ID Contact
22	Range 2 ID Contact
39	Range 2 ID Contact
19	Range 3 ID Contact
18	Range 3 ID Contact
34	Not Used
35	Not Used

3.3.2.8 NETWORK I/O

A serial digital input/output for local network protocol. At this printing, this port is not yet functional. It is to be used in future options to the instrument. Pins 13 (+) and 29 (-).

3.3.2.9 PIN OUT TABLE

The following table summarizes all the outputs/inputs available in the 50 pin D-Sub connector on the back panel of the analyzer.

Table 3-7: Pin out of 50 pin D-Sub Connector

pin #	Description	pin #	Description
1		26	
2		27	
3	+ Output 4-20 ma - Channel 2	28	Alarm 1 C Contact
4	- Output 4-20 ma - Channel 2	29	
5	+ Output 4-20 ma - Channel 1	30	
6	- Output 4-20 ma - Channel 1	31	
7	- Output 0-1 v (Channel 1)	32	Exhaust Solenoid Hot
8	+ Output 0-1 v (Channel 2)	33	Sample Solenoid Hot
9		34	Range 4 Contact/ not used
10	Remote Span +	35	Range 4 Contact/not used
11		36	Alarm 3 NC Contact
12	Remote Span -	37	Alarm 3 NO Contact
13		38	Range 1 Contact
14		39	Range 2 Contact
15		40	Calibration Contact
16	Span Solenoid Return	41	Calibration Contact
17	Span Solenoid Hot	42	Alarm 2 NC Contact
18	Range 3 Contact	43	Alarm 2 NO Contact
19	Range 3 Contact	44	Alarm 2 C Contact
20	Alarm 3 C Contact	45	Alarm 1 NC Contact
21	Range 1 Contact	46	Alarm 1 NO Contact
22	Range 2 Contact	47	
23	- Output 0-1 v (Channel 2)	48	Exhaust Solenoid Return
24	+ Output 0-1 v (Channel 1)	49	
25		50	Sample Solenoid Return

3.3.2.10 RS-232 PORT

The digital signal output is a standard RS-232 serial communications port used to connect the analyzer to a computer, terminal, or other digital device. It requires a standard 9-pin D connector.

Input: The input functions using RS-232 that have been implemented to date are described in Table 3-8.

Table 3-8: Commands via RS-232 Input

Command	Description
AS <enter>	Immediately starts an autospan.
AL <enter>	Immediately revert to Analyze (CH4 Mode)
RL <enter>	Change to Manual Range LOW
RM <enter>	Change to Manual Range MEDIUM
RH <enter>	Change to Manual Range HIGH
RA <enter>	Change to Manual Range AUTO

Implementation: The RS-232 protocol allows some flexibility in its implementation. Table 3-9 lists certain RS-232 values that are required by the Model 4060 implementation.

Table 3-9: Required RS-232 Options

Parameter	Setting
Baud	2400
Byte	8 bits
Parity	none
Stop Bits	1
Message Interval	Sent at the end of each cycle.

3.3.3 Gas Connections

The analyzer gas connection diagram identifies the various gas connection points as to function and location. Figure 3-1 shows the gas connection points for instruments fitted with the optional autocal module.

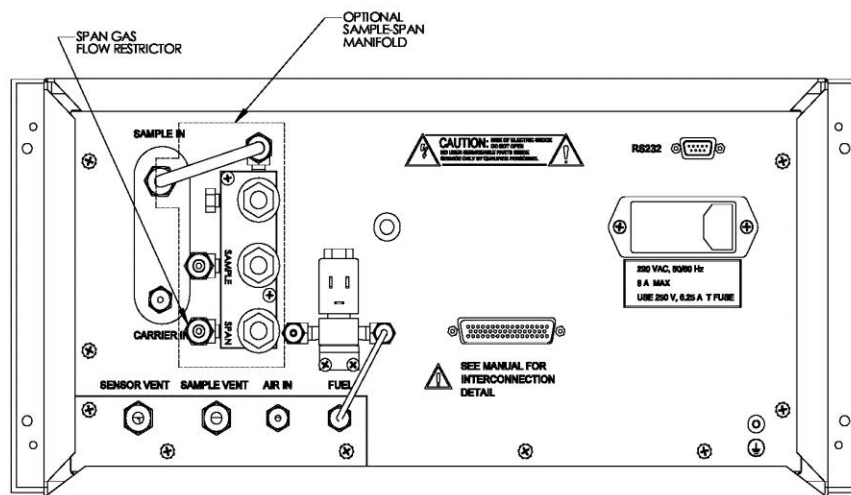

Figure 3-3: Gas Connections

Gas connections to the instrument are made at the 1/8" or 1/4" stainless steel tube fittings provided on the rear panel. Note that the Purge and Sensor Vent fittings are 1/4" while all other gas connections are 1/8".

It is recommended that all gas tubing leading to the connections on the back of the analyzer be of the coiled type. This will facilitate sliding the unit out of the case without disconnecting the gas supply to the analyzer.

Before tubing is connected to the system, it must be decontaminated to eliminate any hydrocarbon deposits. Using a small torch, heat each length of tubing while passing nitrogen through it until it glows red. Begin at the nitrogen source end and proceed down the length of the tube, "chasing" the red glow (and hydrocarbon deposits) down to the open end of the tube. Cap the tubing while not in use with suitable non-contaminating caps.

All sample, calibration, and supporting gas lines, which deliver gas to the analyzer, must be decontaminated before connection; vent lines do not.

When connecting the various gas lines to the system, be absolutely certain that no "dead ends" are left; that is, no unused branch lines should be left capped off, where pockets might form of material that is

not representative of the current contents of the line, or which might keep contaminants from being purged out of the system.

CAUTION: **THE GASES USED MUST BE OF THE HIGHEST QUALITY, ULTRAZERO GRADES, AS SHOWN BELOW. FAILURE TO DO SO WILL RESULT IN CONTAMINATION AND FAILURE TO DETECT LOW PPB BENZENE:**



AIR: **USE WATER PUMPED AIR WITH THC LESS THAN 0.1 PPM. DO NOT USE OIL PUMPED AIR UNDER ANY CIRCUMSTANCES.**

FUEL: **HYDROGEN GAS, 100%, ZERO QUALITY WITH THC LESS THAN 0.5 PPM.**

CARRIER GAS: NITROGEN GAS, ULTRAZERO GRADE WITH THC LESS THAN 0.05 PPM.

Normally, four supporting gases of different composition (see Section 4.1: *Equipment*) will be required to operate the analyzer. The recommended composition is specified Appendix B: Addendum and Testing Results. The gases should be supplied from cylinders that are equipped with the type of regulator specified in the aforementioned sections.

CAUTION: **UNDER NO CIRCUMSTANCES SHOULD YOU EMPLOY A REGULATOR THAT IS NOT EQUIPPED WITH A METALLIC DIAPHRAGM ANYWHERE IN THE SYSTEM.**



The regulators should be inspected prior to installation to be sure that they are oil-free. Failure to comply with these directives will result in a constant drift in analyzer output, as organic compounds will outgas into the plumbing system at a rate that is related to the ambient temperature. Use 316 stainless steel, dual-stage stainless steel diaphragm regulators only in fuel, sample, and blanket air lines; shutoff valves should be used downstream from each regulator.

Place the supply cylinders as close to the analyzer as possible, and connect to the analyzer with new tubing. Be sure that all plumbing connections are free of leaks.

Note: Use only stainless steel tubing throughout the system. Consult the assembly, piping, outline drawings, and any

Addenda included with this manual to determine if special conditions apply.

3.3.3.1 EFFLUENT

All the gases introduced into the detection cell vent from one fitting at the rear of the analyzer. TAI recommends that the cell be permitted to vent directly to the atmosphere wherever possible.

If a vent line is required, the installation must include a drop-out pot to collect the water that is formed by the burning of the hydrogen fuel. The vent line must be constructed so that water and dirt cannot collect in it.

3.3.3.2 SAMPLE BYPASS VENT

The sample bypassed by the back-pressure regulation system vents from a separate port at the rear of the analyzer. If a vent line is required, it must be installed so that water and dirt cannot accumulate in it.

3.3.3.3 FUEL AND AIR CONNECTIONS

The fuel used to provide combustion should be hydrogen gas, zero quality with certified THC of less than 0.5 ppm and supplied at a pressure of 40 psig. The compressed air, ultra zero gas quality with THC less than 0.1 ppm should be used and supplied at a pressure of 40 psig. Connect the fuel and air sources to the instrument according to the gas connection diagram included at the back of this manual.

3.3.3.4 SAMPLE AND SPAN GAS CONNECTIONS

The sample and span gas connections are made at the rear panel. If the optional autocal module is installed, the sample and span gas will connect to this module. If no autocal module is present, these gases connect to the labeled fittings on the rear panel.

Set the supply pressure for sample and span gas to 20 psig.

3.4 Placing the System in Operation

See Section 4 for information on starting the analyzer for the first time. Make sure that all electrical connections have been made correctly and all connectors are fully seated. Make sure all gas connections are correct and leak-free.

Operation

This section of the manual describes how to setup and operate the Model 4060 Analyzer. Sections 4.1 through 4.5 describe preliminary steps and equipment needed to operate the analyzer. Beginning with Section 4.6, the actual operation of the analyzer is described along with descriptions of the display prompts, messages and options available to the user within a menu or sub menu. You should read this chapter in its entirety and become familiar with the operating characteristics of this system before starting the analyzer for the first time. The *Addendum and Testing Results* section of Appendix B lists the software revision and default settings for your specific system.

4.1 Equipment

The following supporting gases and hardware will be required to operate the (standard) analyzer:

1. **Fuel:** A cylinder containing a hydrogen gas, zero gas quality composition will be required to supply the fuel for the flame ionization burner. The cylinder is to be equipped with an oil-free metallic diaphragm regulator (dual stage).
2. **Blanket Air:** A cylinder of compressed air, zero gas quality will be required to maintain the proper atmosphere within the cell. The cylinder is to be equipped with an oil-free, dual stage, metallic diaphragm regulator.
3. **Carrier Gas:** A cylinder of nitrogen gas, zero gas quality, equipped with dual stage metallic diaphragm regulator is required.
4. **Span Gas:** A cylinder or a permeation device system, capable of generating known concentration of benzene and/or other aromatic hydrocarbons of interest, will be required to standardize the analyzer.
5. **Sample Pressure Regulation:** An oil-free, metallic diaphragm regulator must be installed at the sample point when possible; see Section 3.3.3 *Gas Connections*.

Note: The standard unit does not require a zero calibration gas, however if your unit is fitted with the optional thermal conductivity detector, a zero gas and zero calibration will be necessary.

CAUTION:  **THE GASES USED MUST BE OF THE HIGHEST QUALITY, ULTRA ZERO GRADES, AS SHOWN BELOW. FAILURE TO DO SO WILL RESULT IN CONTAMINATION AND FAILURE TO DETECT LOW PPB BENZENE.**

AIR: USE WATER PUMPED AIR WITH THC LESS THAN 0.1 PPM. DO NOT USE OIL PUMPED AIR UNDER ANY CIRCUMSTANCES.

FUEL: HYDROGEN GAS, 100%, ZERO QUALITY WITH THC LESS THAN 0.5 PPM.

CARRIER GAS: NITROGEN GAS, ULTRA ZERO GRADE WITH THC LESS THAN 0.05 PPM.

4.2 Preliminary Power-Off Check List

Make the following checks of the installation before proceeding further into the start-up procedure:

1. Check to see that the sample and supporting gas installation is in accordance with the specifications called for in the installation and application sections of the manual (Chapter 3). Be sure that the supporting gases are of the proper composition and are connected to the correct fittings at the rear of the analyzer.
2. Check to see that the electrical installation conforms to the instructions contained in the installation section (Chapter 3) and on the input-output diagram.
3. Open the door and check to see that the printed circuit boards and cables are firmly seated in their respective sockets.
4. Confirm that recorder and alarm connections are properly made.

4.3 Activating the Support Gases

All gas controls are located on the front panel as shown in Figure 1-1.

4.3.1 Air

1. Set the air source regulator to 40 psig.
2. Adjust the analyzer air regulator until the air pressure gauge reads the recommended air pressure of 7.0 psig.

After the air is flowing through the sensor and warm-up time has been completed, activate the following gases:

4.3.2 Carrier Gas

Set the carrier gas source regulator to 80 psig and adjust the analyzer sample regulator until the sample pressure gauge reads the recommended sample pressure of 7.0 psig.

4.3.3 Span Gas

1. Feed span gas to the analyzer (see Section 4.6.5). Gas switching can also be handled through the autocal valves (if the option is added), which can also be manually activated as described in Section 4.6.5.
2. Observe that the analyzer sample flow meter reads from 0.3 to 1.0 SCFH.

4.3.4 Fuel

1. Open the main valve on the fuel source and set the fuel pressure regulator to 40 psig.
2. Adjust the fuel regulator until its pressure gauge reads the recommended pressure of 4.0 psig.

Note: Adjust fuel settings only when the red LED (flame failure light) is off.

4.4 Flame Ignition

Observe that after warm up count down timer reaches zero (timer to preheat the sensor), the amber heater lamp is blinking (indicating that

the temperature controller is maintaining the temperature setpoint) and the red Flame Out lamp is on. See Figure 1-1.

The Model 4060 will automatically attempt a flame ignition sequence following the warm up period which has been preset at the factory. If the ignition process fails, the instrument will attempt to ignite the flame 4 more times. If it continues to fail after the fifth attempt, a flame failure message will appear on the display. If this occurs refer to Section 5.

4.4.1 Verification of the Flame Guard Circuit

The operation of the flame guard circuit has been checked at the factory, but should be re-verified during start-up. Use the following procedure after ignition of the flame has been achieved:

1. Turn off the fuel at the supply cylinder.
2. Observe the fuel pressure gauge on the analyzer control panel. The gauge indication will decay as the fuel in the line is exhausted. When the gauge reading reaches near zero, the flame will extinguish as the fuel solenoid shuts off the fuel supply. The analyzer will automatically try to re-ignite. After 5 attempts, it will display: flame failure, check air, fuel and the flame failure LED will be on.
3. Open the cylinder supply valve and re-ignite the flame by pushing the up and down buttons simultaneously.

4.4.2 Ignition and/or Flame Guard Circuit Failure

If the flame ignition or guard circuits do not operate as described in the above two sections, set the instrument fuel regulator to the recommended pressure. If still fails to ignite, proceed as directed in Chapter 5: *Maintenance & Troubleshooting*.

4.5 Sample Pump

A built-in sample pump is provided to draw sample gas from ambient air. The gas flow rate should be maintained at about 1000 to 1200 cc/minute using the Front Panel flow control valve (clockwise increases flow). See Figure 1-1.

4.6 Analyzer Operation

Although the Model 4060 has been programmed for your application at the factory, it can be further configured at the operator level. Depending on the specifics of the application, this might include all or a set of the following procedures:

1. Setting system parameters
 - Establish a security password, if desired, requiring operator to log in.
 - Establish and start an automatic calibration cycle (if equipped with the optional autocal module).
2. Routine operation.
 - Calibrate the instrument.
 - Choose autoranging or select a fixed range of analysis.
 - Set alarm setpoints and modes of alarm operation.
3. Special functions setup.
 - Calibrate analog output, select analog output source.

Procedures for accessing and/or changing parameters as well as analyzer operation are detailed in the sections to follow. In general, the sequence of menus available on screen follows a logical course for setup and operation. It is not required, however to follow this sequential path. The user could, for instance, go directly to set an analysis range and then program an offset to the current output for matching a range on the user's recording device. The only exception to this is when the instrument is powered up. It will go through a warm-up period, followed by a diagnostic self-test routine.

Caution:



ALARM SUPPRESSION:

When an alarm condition occurs (see ALARMS), one or both of the messages, 'AL-1', and/or 'AL-2' will be displayed on the VFD while in the ANALYSIS SCREEN. At this time, the ENTER button may be pressed to acknowledge the alarm(s) in which case the alarms will be suppressed until the analysis value is next updated. This can result in a condition where the screen may be reporting a value that should

cause an alarm, but until the analyzer again enters SAMPLE MODE, no alarm condition will reoccur.

4.6.1 Default Parameters

The versatility of this analyzer usually results in significant changes being made to parameters over the course of time to better suit a particular application. Occasionally processes change requiring alteration to alarms, filter settings etc. At some time, it may be beneficial to reset the analyzer to the default conditions as it was when shipped from the factory. Below is a listing of the default parameters used in configuring the typical Model 4060 instrument. Your specific application may require different settings. Refer to the *Addendum and Testing Results* section of Appendix B for any specific changes or recommendations that apply to your application.

Range/Application: Refer to the *Addendum and Testing Results* section of Appendix B

Range: Manual

Alarms: Defeated, 20ppb, 50ppb, HI, NON-FAILSAFE, NON-LATCHING

Auto Span Timing: Defeated, every 7 days, at 12 hours

Span: 80 ppb

Password: TAI

4.6.2 Style Conventions

The following typeface conventions are used when referring to screen names, key presses and screen readout:

Screens: Arial 12 pt. type in capital letters.
Example: ANALYZE or MAIN screen or menu.

Key Presses: <key> The particular keystroke to enter is placed between < and >.
Example: <enter> or <escape> or

<▲> (UP key) or <▼> (DOWN key).

Only when the keystroke is to be entered will it be placed between the brackets. If discussing a particular key it will be typed as text using all caps. Example: this is the ENTER key.

Screen Modes: Times New Roman 12 pt. italic.
Example: *Analysis Mode* or *Setup Mode*.

Screen Readout: Arial Narrow, 12 pt bold.
Example: **AUTOCAL**.

4.6.3 Navigation and Data Entry

Note: All menus time out after 15 (fifteen) seconds elapse with no button presses, the analyzer returns to the ANALYSIS SCREEN, if parameters have been altered but not saved (with the ENTER key), the alterations are lost.

Navigation and Data Entry is possible using 2 ARROW KEYS, the ENTER key, and the ESCAPE key. It is important to read and understand the MENU STRUCTURE section to fully understand navigation and data entry.

4.6.3.1 ARROW KEYS

Pressing the ARROW KEYS select menus and modifies values.

1. In the ANALYSIS SCREEN, the ARROW KEYS cause entry into the MAIN MENU.
2. When the selected option is a function on the MAIN MENU or any SUB MENU screen, the ARROW KEYS move to the next lower or upper menu.
3. If the selected option is a MODIFIABLE ITEM (value is flashing), The ARROW KEYS increment or decrement numeric values or toggle ON/OFF, YES/NO, or ENABLE/DISABLE type values.

4. The arrow keys, when pressed simultaneously, are used to manually ignite the flame after a flame-out condition.

4.6.3.2 ENTER

The ENTER key is used in several context-sensitive ways.

1. When the selected option is a function on the MAIN MENU or any SUB MENU screen, the function name appears **with an arrow next to it**. In some cases, the item in the menu is the parent of another SUB MENU, in other cases, the item in the menu is the parent of a MODIFIABLE ITEM.
2. If the selected option is a MODIFIABLE ITEM, the ARROW KEYS are used to modify the value of the item. **A modifiable item is flashing**. The ENTER key is then used to accept the value and move you to the next field to continue programming.

4.6.3.3 ESCAPE

The ESCAPE key is used in several context-sensitive ways.

1. When displaying the analysis mode, the ESCAPE key temporarily clears any present alarms. However, if the alarm condition is still present, the alarm will re-occur when re-detected. Also, pressing the ESCAPE key clears the messages generated by incorrect gain settings (i.e. bad span, gain too high).
2. When the selected option is a function on the MAIN MENU or any SUB MENU screen (the menu name appears with a flashing arrow next to it), the ESCAPE key is used to return to the parent menu finally returning to the ANALYSIS SCREEN the function.
3. If the selected option is a modifiable item (value is flashing), The ESCAPE key is used to escape to the parent menu **without saving the value**. The value will revert to the original before modification (if any).

4.6.4 Menu Structure

The 4060 screen setup consists of several classes of screens and items. No item occupies more than 1 line. It is important to read and

understand the NAVIGATION AND DATA ENTRY section to fully understand the menu structure.

1. The ANALYSIS SCREEN displays the analysis value, the range, the alarms (if any) and some information about what phase of analysis is occurring.
2. The MAIN MENU and SUB MENU screens have a flashing arrow on the left side indicating which item is being pointed to.
3. MODIFIABLE ITEM screens have a flashing value somewhere in the line.

4.6.4.1 MAIN MENUS

The MAIN MENU consists of 21 functions you can use to customize and check the operation of the analyzer. Not all functions are operational in the standard instrument. The functions that appear are listed here with brief descriptions:

- SPAN: Set up and/or start a span calibration
- ALT-SPAN: Set up and/or start an alternate span calibration.
- *ZERO: Perform a zero calibration on units with the optional thermal conductivity detector.
- MODEL: Displays Manufacturer, Model, and Software version of the instrument.
- SELF-TEST: The instrument performs a self-diagnostic routine to check the integrity of the power supply, output boards, cell and amplifiers.
- ALARMS: Used to set the alarm setpoints and determine whether each alarm will be active or defeated, HI or LO acting, and failsafe or not.
- RANGE: Used to set up three analysis ranges that can be switched manually.
- ANALOG-OUT ADJUST: Adjust the analog output with offset and scaling.
- LINEARIZATION: Linearization option.

- CHANGESTREAM: (optional feature) Controls a relay switch for using alternate gases. Has no effect during span mode (span gas relay setting used at that time).
 - AUTO-CAL: Used to define and/or start an automatic calibration sequence. *AUTOCAL is an optional feature not included in the standard configurations of the 4060.*
 - TIMING: Low level application specific timing parameters. Factory set. Do not change these.
 - GROUP SETUP: Determines compound names, associated timing and measurement ranges. Do not change these.
 - *DETECTOR: Allows selection between optional detectors.
 - *TC ADJUST: perform coarse and fine gain adjustments on the thermal conductivity detector.
 - *SERIAL MODE: Selects between various communication modes.
 - PASSWORD: Used to establish password protection or change the existing password.
 - LOGOUT: Logging out prevents unauthorized tampering with the analyzer settings.
 - *SERIAL NUMBER: Used with Valve Box configured units for inputting Valve Box serial number for Profibus communication.
 - *REMOTE STREAM: Used with Valve Box configured units to select input stream.
 - STANDBY: Removes power to outputs and displays, but maintains power to internal circuitry.
- * *These functions only function with the associated optional feature. Although the screens appear, input is ignored by the instrument if the specific option is not installed.*

Any function can be selected at anytime. Just scroll through the MAIN MENU with the DOWN/UP keys to the appropriate function, and ENTER it. The analyzer will immediately start that function, unless password restrictions have been assigned. (Password assignment is explained in Section 4.6.17).



4.6.5 Span

The SPAN function is used to calibrate the analyzer. Span can be performed either manually or automatically with the autocal function if equipped.

The analyzer is calibrated using span gas as described in Section 4.1. This section assumes that this gas has been properly connected and the line checked for leaks.

To initiate a span calibration:

<UP/DOWN >From the MAIN MENU, scroll down to the SPAN function.

<Enter> Press <Enter> to activate the SPAN function.

-> Span 80.00 ppb

Span Begin

The first line allows the user to modify the span target value.

The second line commences the span after the following query:

Begin Span:

ENTER-YES ESCAPE-NO

Pressing <Enter> enters the SPAN mode in the Sampling Phase. This is similar to the Analysis Mode both in the Sampling Phase and Analysis Phase. The difference is that, at the end, the analyzer calculates the calibration constants rather than the standard concentration calculation. After both Sampling Phase and Analysis Phase are complete, the calculation is performed and the 40660 re-enters Analysis Mode.

4.6.6 ALT-SPAN

If a particular compound of interest is not contained in the span gas, another compound existing in the span gas can be used for the alternate calibration.



4.6.7 The Model Screen

The MODEL screen displays the model, and software version information. It is accessed via the MAIN MENU by scrolling (UP/DOWN > to MODEL and pressing <Enter>.

4.6.8 System Self-Diagnostic Test

The Model 4060 has a built-in self-diagnostic testing routine. Preprogramming signals are sent through the power supply, output board, preamp board and sensor circuit. The return signal is analyzed, and at the end of the test the status of each function is displayed on the screen, either as GOOD or BAD. If any of the functions fail, the System Alarm is tripped.

Note: The self diagnostics are run automatically by the analyzer whenever the instrument is turned on, but the test can also be run by the operator at will.

Note: The self diagnostics will interrupt analysis temporarily.

To initiate a self-test:

<UP/DOWN >From the MAIN MENU scroll to the SELF-TEST function.

<Enter> Activate the SELF-TEST function by pressing <Enter>. This brings up the SELF-TEST initialization screen.

Begin Self-Test?

ENTER=Yes ESCAPE=NO

<Enter or Escape> Start the diagnostic testing routine by pressing <Enter> or cancel out by pressing <Escape>.

If you pressed <Enter> the self-test routine will begin and after a few moments the results will appear onscreen. The module is functioning properly if it is followed by GOOD otherwise it is followed by BAD. In this case, please contact TAI Customer Service for an explanation of the problem.

To return the analyzer to the MAIN MENU, press <Enter> after the results screen.

If you pressed <Escape> you will be returned to the *Analyze Mode*.

4.6.9 The Alarms Function

The Model 4060 is equipped with two alarms and a system failure alarm relay. Each alarm relay has a set of form "C" contacts rated for 3 amperes resistive load at 250 VAC. See Figure in Chapter 3, *Installation* and/or the Interconnection Diagram included at the back of this manual for relay terminal connections. The alarm relay contacts are accessible to the user from 50-pin Equipment Connector. See Section 3.3.2.5 and Table 3-2.

The system failure alarm has a fixed configuration described in Chapter 3 *Installation*.

The concentration alarms can be configured from the ALARM function screen as follows:

-> AL-1 DEFEATED
AL-1 HIGH
AL-1 NON-FAILSAFE
AL-1 NON-LATCHING
AL-1 20.00 ppb
AL-2 ACTIVE
AL-2 LOW
AL-2 FAILSAFE
AL-2 LATCHING
AL-2 50.00 ppb

Note: For the purpose of example, Alarm 2 has been set differently than Alarm 1.)

Note: An alarm in 'alarm condition' is signaling that action must be taken such as correcting the alarm or the analysis concentration. If an active (not defeated) alarm has been set to HIGH at 20.0 ppb, and the analysis concentration is above that level, then the 'alarm condition' is occurring.

DEFEATED: If an alarm is defeated, its relay is de-energized, regardless of failsafe condition. A defeated alarm does not react to a transition over its trip point in either direction.

HIGH: If an alarm is set as HIGH, it will not create a new alarm condition (see latching) if the analysis concentration is below the trip point, if the analysis concentration is above the trip point, then an alarm condition will be created or maintained.

FAILSAFE: A non-defeated alarm that is in FAILSAFE mode *energizes* an alarm relay in a non-alarm condition and *de-energizes* an alarm relay in an alarm condition.

Note: Failsafe condition of an alarm is in software. This is not related to relays that have both normally-open and normally-closed terminals.

LATCHING: The latching property configures the alarm such that the user must manually relieve the alarm condition even though the concentration no longer violates the trip point of the alarm. So, if an alarm is NON-LATCHING, and the analysis concentration temporarily drifts above the trip point of a HIGH alarm, the alarm condition occurs only during the time the concentration is above the trip point. If that alarm were LATCHING, the alarm condition would persist (even though the concentration is no longer above the trip point), until the user released it.

RELEASING A LATCHED ALARM: When alarm conditions are present, the main analysis screen will have one or both of the following messages: 'AL-1', 'AL-2' followed by the instruction 'ENT/ACK'. Pressing ENTER will release a latched alarm. That is, if there will not be an alarm condition until the analysis concentration is again violating the trip point. Furthermore, the alarms will be suppressed until the analysis value is updated, so even though the screen may be reporting a value that should cause an alarm, until the analyzer again enters SAMPLE MODE, no alarm condition will reoccur.



TRIGGER POINT: This is the threshold at which an active alarm can enter into alarm condition. If an alarm is HIGH, ACTIVE, and set at 20.00 ppb, then when the analysis concentration is at or above 20.00 ppb an alarm condition is initiated or maintained.

CAUTION:

IT IS NOT GOOD PRACTICE TO SILENCE AN EXISTING ALARM BY SETTING THE ALARM ATTRIBUTE TO 'DEFEAT'. THE ALARM WILL NOT AUTOMATICALLY RETURN TO "ACTIVE" STATUS. IT MUST BE RESET BY THE OPERATOR. IF IT IS NOT RESET, YOUR PROCESS WILL BE RUNNING WITHOUT THE SAFEGUARDS THIS INSTRUMENT IS DESIGNED TO PROVIDE.

4.6.10 The Range Function

-> Range Select: Man

Man Rng: R1

R1: 0-100.00ppb

R2: 0- 1.00ppm

R3: 0- 10.00ppm

The value of the upper limit of the currently selected range (AUTO or MANUAL) affects the voltage and current of the analog outputs on the rear of the analyzer as well as contact closures indicating which range is current. The analog outputs from the 50 –pin Equipment connector (see Section 3.3.2.4 and Table 3-1) represent the proportion of the analysis concentration to the currently selected range limit.

MANUAL/AUTO RANGE SELECT: In Manual Range Select, the range indicated on the second line 'Man Rng:' is maintained as the current range of operation. In Auto Range select, the software determines the smallest range whose limit is larger than the analysis concentration. Automatic Range selection in Auto Range is governed by hysteresis such that the concentration must fall below 90% of the limit of the next smaller range before the current range will be set to the lower range.

RANGE LIMITS: Ranges may be set as low as 100.0 ppb and as high as 100.0 ppm. Range 3 can only be set at a value greater than Range 2. Range 2 can only be set at a value greater than Range 1.

4.6.11 Analog Output Adjustment

The software in this instrument provides a way to enter to manage the analog output of the analyzer. To access the offset function:

<UP/DOWN > From the MAIN MENU, scroll to the ANALOG ADJUST function using the UP/DOWN keys.

<Enter> Pressing <Enter> activates the function and takes you to the next screen.

-> CH1 Offset

CH1 Gain

CH1 (Wave, Id for Ch2, or Group Output)

CH1 (Select Groups)

CH2 (Wave, Id for Ch2, or Group Output)

CH2 (Select Groups)

4.6.12 Linearization

Not applicable to the 4060 configuration.

4.6.13 Changing Stream

Affects the relay on the rear panel that controls which gas is allowed to flow to the column and detector.

When the instrument has electronically controlled calibration valves (option), the gas stream can be switched here. You can flow span, sample (or zero gas) without entering the calibration mode in order to



check instrument response. During a span calibration, the span stream is activated. After a span calibration, the sample stream is activated regardless of what was set before the span.

4.6.14 Setting up an AUTO-CAL

The Series 4060 Analyzer can be fitted with an external auto calibration module as an option. This feature provides automatic switching of sample and calibration gases and allows the operator to program calibration events to occur automatically

Note: If your instrument is not fitted with an autocal module, the autocal screens will still appear on the display but will be non-functional.

Note: Before setting up an AUTOCAL, be sure you understand the Span functions as described in Section 4.6.5, and follow the precautions given there. Auto Span performs a span calibration using the target span value set in the Span feature menu.

Note: If you require highly accurate AUTOCAL timing, use external AUTOCAL control where possible. The internal clock in the Model 4060 is accurate to 2-3 %. Accordingly, internally scheduled calibrations can vary 2-3 % per day.

To setup an autocal cycle for a span event to occur in a certain number of days/hours:

From the Analysis Screen, press the UP or DOWN key to enter the *Setup Mode*. The VFD will display the first 2 lines of functions available.

-> AUTOCAL
PASSWORD

<UP/DOWN> If the arrow is not adjacent to the AUTOCAL menu item, use the UP/DOWN keys to move the arrow to the proper position.

<Enter> Press <Enter> to activate the function and move you to the next screen.

Here are the autocal parameters (with an example of data). The underlined items are modifiable (but not underlined in the actual display):

-> AS:3d 20h
AUTO SPAN Enabled
Span in 11 days
Span in 6 hours

Note: For instruction on how to set the parameters, please refer to the Data Entry section.

The first line tells how soon the next automatic span will occur. Pressing <Enter> on this line has no effect.

The second line Enables/Disables the Auto Span. When the Auto Span is enabled, the values in the first line count down to zero, at which time Analysis is aborted and a Span Cycle is started in the Sample Phase (See Theory of Operation).

When the Auto Span is disabled, the countdown is halted, but the Days and Hours remain and will commence countdown if the Auto Span is re-enabled.

The 3rd and 4th lines modify the days and hours until the next Auto Span occurs. When these are changed and <Enter> is pressed, the Auto Span is re-set to occur according to the number of Days/Hours set. The first line will reflect the new count down.

4.6.15 Timing

Timing controls the parameters of the valve and data acquisition. It is specific to the setup of the instrument and must be determined at the factory or TAI trained personnel. Refer to the *Addendum and Testing Results* section of Appendix B for the specific timing settings used for your system and application. Do not change these values unless directed

by Customer Service at TAI. For further information please contact TAI Customer Service.

4.6.16 Group Setup

Group Setup assigns to each compound a name, a range given in Range settings and an associated peak window that is determined in Timing settings. These values should not be modified unless directed by TAI customer Service.

4.6.17 Password Protection

Before a unique password is assigned, the system assigns TAI by default. If the password is the default, it will be displayed automatically. The operator just presses <Enter> from the any of the MAIN MENU items to be allowed access to that item's sub menu. If the password has previously been changed from the default then the initial display will be 'A' 'A' 'A', and the correct letters must be input.

If user has LOGGED OUT, then only the following SUB MENU procedures may be executed:

1. PASSWORD
2. LOGOUT (which only repeats the logout)
3. MODEL

Note however, that the instrument can still be used for analysis without entering the password. To defeat security the password must be entered .

Note: If you use password security, it is strongly advised to keep a copy of the password in a separate, safe location. If the password is lost and security is enabled, the analyzer must be cold-booted. Cold booting invalidates parameters necessary for correct operation so they must be re-entered.

ENTERING A PASSWORD

To install a new password or change a previously installed password, you must key in and ENTER the old password first. If the default password is in effect it will be displayed as the default gausses for each letter, pressing <Enter> for each letter of the password will enter the default password for you.

To enter a password:

<any key> From the ANALYSIS SCREEN Enter MAIN MENU setup by pressing an UP/DOWN KEY.

<UP/DOWN >Use the UP or DOWN key to scroll to

PASSWORD

AUTOCAL

-> PASSWORD

<Enter> Press <Enter> to activate the password function. Either the default TAI password or AAA place holders for an existing password will appear on screen.

ENTER PASSWORD SCREEN

Enter a Password

'T'A'I'

<UP/DOWN >Use the UP/DOWN keys to change the letters to the proper password.

<Enter> Press <Enter> to advance to the next letter

<Enter> The last <Enter> enters the password.

<Escape> Steps back to the previously entered letter or, if on the first letter, returns to the MAIN MENU.

If the correct password has been entered the 4060 now allows access to all the SUBMENU items.

The 4060 next presents the CHANGE PASSWORD screen.

CHANGE PASSWORD SCREEN

-> Change Password

-
- <Escape>** Press <Escape> to return to the MAIN MENU, you are now logged in and have access to ALL SUBMENU items.
- <Enter >** Press <Enter> to change the password.

ENTER NEW PASSWORD SCREEN

Enter a new Password**'T' 'A' 'I'**

-
- <UP/DOWN >**Use the UP/DOWN keys to change the letters to the new password.
- <Enter>** Press <Enter> to advance to the next letter
- <Enter>** The last <Enter> moves to the REPEAT PASSWORD ENTRY screen.
- <Escape>** Steps back to the previously entered letter or, if on the first letter, returns to the CHANGE PASSWORD menu.

REPEAT PASSWORD ENTRY SCREEN

Reenter a new Password**'A' 'A' 'A'**

Note that the new password has been replaced by 'A' as placeholder characters. This is to ensure that the wrong password is not mistakenly entered.

- <**UP/DOWN**> Use the UP/DOWN keys to reenter the letters of the new password.
- <**Enter**> Press <Enter> to advance to the next letter
- <**Enter**> If the repeated password matches the previously entered new password, the new password is set, the 4060 resumes the ANALYSIS SCREEN after displaying a brief message 'Password Changed'.
- <**Escape**> Steps back to the previously entered letter or, if on the first letter, returns to the CHANGE PASSWORD menu.

Note: If you log off the system using the LOGOUT function in the MAIN MENU, you will now be required to reenter the password to gain access to most menus.

4.6.18 Logging Out

The LOGOUT function provides a convenient means of leaving the analyzer in a password protected mode without having to shut the instrument off. By entering LOGOUT, you effectively log off the instrument leaving the system parameters protected until the password is reentered. The system will continue analysis, however.

To log out:

- <**UP/DOWN**> From the MAIN MENU scroll to field of LOGOUT function.
- <**Enter**> Press <Enter> to logout
The screen will display the message:

Restrict Access?

ENTER=Yes ESCAPE=NO

Pressing <Enter> will logout the current user and protect the system from unauthorized changes to parameters.

If user has LOGGED OUT, then only the following SUB MENU procedures may be executed:

1. PASSWORD
2. LOGOUT (which only repeats the logout)
3. MODEL

Note however, that the instrument can still be used for analysis without entering the password. To defeat security the password must be entered .

4.6.19 Standby

This function allows you to place the instrument in STANDBY.

CAUTION: STANDBY SHUTS DOWN POWER TO THE DISPLAYS ONLY. INTERNAL CIRCUITS ARE STILL ENERGIZED AND ELECTRICAL SHOCK HAZARD STILL EXISTS.



To place the instrument in STANDBY status:

<**UP/DOWN**> From the MAIN MENU, scroll to the STANDBY function using the UP/DOWN keys.

<**Enter**> Pressing <Enter> places the instrument in STANDBY.

To exit STANDBY, scroll again to the STANDBY function and press <Enter> again.

Maintenance & Troubleshooting

WARNING: *DANGEROUS HIGH VOLTAGES EXIST INSIDE THIS INSTRUMENT.*



THERE ARE NO USER SERVICEABLE PARTS WITHIN THE COVER ON THE INSIDE OF THE DOOR, INSIDE THE ISOTHERMAL CHAMBER, (SAMPLE SYSTEM), AND ON THE ELECTROMETER-AMPLIFIER PC BOARD. WORK IN THESE AREAS MUST BE PERFORMED BY AUTHORIZED AND TRAINED PERSONNEL ONLY.

BEFORE STARTING ANY OF THESE MAINTENANCE AND TROUBLESHOOTING PROCEDURES, READ THE CAUTIONS AND WARNINGS INCLUDED IN THE SECTION TITLED "ADDITIONAL SAFETY WARNINGS". PAY SPECIFIC ATTENTION TO THE PROCEDURES FOR REMOVAL OF INTERNAL INACCESSIBLE SHOCK HAZARDS. IF THE INSTRUMENT MUST BE TURNED ON DURING ANY OF THESE MAINTENANCE AND TROUBLESHOOTING PROCEDURES, BE CAREFUL AND WORK WITH THE ONE HAND RULE:

Work with one hand only.

Keep the other hand free without contacting any other object. This reduces the possibility of a ground path through the body in case of accidental contact with hazardous voltages.

CAUTION: *MANY OF THE ELECTRICAL PARTS WITHIN THE ANALYZER ARE SUSCEPTIBLE TO DAMAGE FROM ELECTROSTATIC DISCHARGE (ESD). USE ESD SAFE PROCEDURES WHEN HANDLING OR WORKING WITH ELECTRONIC COMPONENTS.*



If the analyzer is suspected of incorrect operation, always evaluate performance with zero or span gas flowing in the sample path. Never

attempt to evaluate performance on sample gas. If analyzer sensitivity is questionable, use the span gas. For all other evaluations, use the zero gas and low range for maximum sensitivity. The important consideration is to control as many variables as possible. Using cylinder-supplied gases of known hydrocarbon content eliminates the possibility of introducing an unknown variable.

Do not overlook the seemingly obvious. Check to see that power is available for the instrument (and of the proper voltage, etc.), and that connections are correct. Also verify that support/calibration gases are not depleted.

5.1 Measuring Circuit Electrical Checks

If the analyzer performs erratically on span gas, the trouble can be related to either the integral gas control systems, or the electronics. To isolate the problem, the two systems must be separated. To isolate the electronics, employ the following procedure:

- Open the door to the analyzer, remove and disconnect the collector cable from the sensor leaving it attached to the electrometer board. (Consult schematic and assembly drawings for circuitry and location). With this cable disconnected, the electronic circuitry is completely isolated from the gas control system and cell.

5.1.1 Anode Voltage Check

If the output can be adjusted by the zero control (the above section, step 2), the cell anode voltage should be verified as follows:

WARNING: *THESE PROCEDURES SHOULD BE CARRIED OUT ONLY BY PERSONNEL FAMILIAR WITH HIGH VOLTAGE CIRCUIT BOARDS. THE ANODE-IGNITER UNIT AND ASSOCIATE CIRCUITRY INVOLVE DANGEROUSLY HIGH VOLTAGES.*



Refer to the cell wiring diagram. Using a voltmeter set to measure 125 VDC, check the voltage on either of the anode-igniter electrodes, as follows:

1. Connect the **negative** voltmeter lead to ground and the **positive** lead to either electrode. Be careful not to short the circuit by touching both an electrode and the cell body simultaneously. The reading obtained should be 125 ± 10 VDC.

2. If no reading is obtained, disconnect the anode-igniter cable and check for the voltage on pin "J4-1" of the connector located at PC board part number B74671. If the proper voltage is still not present, replace the flame guard and anode power supply PC board. If it is, check the wiring in the anode-igniter cable plug. If necessary, the circuit board can be replaced by first turning off the power, then removing 4 screws holding the board.

WARNING: *DO NOT TOUCH CAPACITOR C1 OR C2 OR THEIR RELATED CIRCUIT FOILS. A SHOCK HAZARD MAY EXIST.*



3. Carefully remove the circuit board without touching any connections which might lead to C1 or C2. After removal, discharge the two capacitors by placing a jumper wire across each.
4. The anode voltage may also disappear or be greatly diminished when condensation inside the sensor has occurred, shorting the igniter to the sensor body across the wet insulator. This usually occurs when the flame is turned on, if the sensor has not been preheated for at least 1 hour.

5.1.2 Electronic Stability

If the checks outlined above indicate that conditions are normal, allow the analyzer to run electronically with the collector cable disconnected for several hours in the lowest range, and with the zero offset value adjusted so that the recorder is reading midscale. If all is normal electronically, a noise-free (pen width) recording, showing absolutely no instability, should be obtained for as long as the analyzer is allowed to run in this configuration. If the recording obtained is noisy or erratic, replace the electrometer-amplifier PC board.

5.1.3 Printed Circuit Board Replacement

If performance is not adequate, then the analyzer must be recalibrated as described in Section 4.6.5: *Span* before being placed back in service.

Whenever the flame guard and anode power supply printed circuit board have been replaced the analyzer must be recalibrated.

If the instrument performs as outlined in this section, the problem is not related to the measuring circuit electronics.

5.1.4 Collector Cable

Before reconnecting the collector cable, check the continuity of the center wire of the cable with an ohmmeter by measuring between the center pins at each plug on the lowest resistance scale of the meter. Flex the cable while making this measurement to be sure that there is not an intermittent open circuit. If there is, replace the cable. Do not attempt to repair the cable, as special tooling is required to disassemble and reassemble the cable plugs.

5.2 Temperature Control Electronic Check

If the heating circuit fails, the output of the analyzer will tend to drift with changes in ambient temperature. Such a failure will be more evident in the low range. If the temperature environment surrounding the analyzer is closely regulated, failure in this circuit might go unnoticed after the initial failure. If the environment follows day and night temperature changes, the analyzer will show a diurnal, bi-directional drift when operated on zero gas. The magnitude of the drift will be a function of the temperature differential experienced by the analyzer.

The Model 4060 uses three PID temperature controllers (P/N CP2408) for controlling the thermal environment in the sample compartment, FID, and the GC Column. The temperature controllers use a thermocouple (typically, type K) for providing feedback to the temperature controller.

The setpoints and control parameters have been set at the factory for your application. These are listed in Appendix B of this manual.

Refer to the PID Temperature Controller Manual for maintenance and troubleshooting information the temperature control units.

Note: If any of the components located inside the isothermal chamber have failed, the instrument must be removed for service.

5.3 Ignition and/or Flame Guard Circuit Checks

If the flame guard circuit will not hold the flame-out lamp off when the ignition procedure is employed (see section 4.4 *Flame Ignition*), perform the following procedure to isolate the problem (consult the system schematic for details of the circuit):

1. Disconnect the anode-igniter/flame guard thermistor cable from the socket.
2. Check the flame guard sensing thermistor by measuring the resistance between pins J4-3&4 of PCB part number B74671, disconnect the cable plug. The reading should be about 100 K Ω at room temperature. The actual resistance is not important, since the thermistor experiences radical changes in resistance as the temperature changes. No indication in a sufficiently high range on the ohmmeter indicates an open thermistor. (If the thermistor is hot, the resistance will be much lower.)
3. Check the anode-igniter coil for continuity by measuring between pins J4-1&2 of the disconnected cable plug. The ohmmeter should indicate a short circuit.
4. If either step 2 or 3 does not check as indicated, remove the electrode assembly of the detection cell and replace it. If the quartz flame tip is damaged, the top section of the cell may be removed by disconnecting the vent line, and removing the screws around its flange. Return the unit complete with attached electrode cable. If steps 2 and 3 both check out properly, reconnect the anode-igniter cable.
5. Check K1 and K2 relays operation as the analyzer is RE-IGNITING. If the relays do not energize, remove the flame guard power supply board and check the forward and backward resistance of its transient suppression diode by measuring pins 13 and 14 of the relay socket. The ohmmeter should indicate a short circuit resistance in one direction, and some resistance value when the leads are reversed. If the indication is a short circuit, then the diode must be replaced.

Note: If, after replacing a defective diode, the circuit still does not work properly, the flame guard circuit components have been damaged, and the PC board must be replaced.

6. If the preceding steps check out correctly, the flame guard portion of the circuitry on the flame guard/anode power supply PC board is defective.

IMPORTANT: If the circuit proves defective, the analyzer will have to be recalibrated after the board is replaced.

5.4 Sampling System

If the procedures outlined above do not correct the problem, the fault must be related to the gas control systems. Plugged or faulty regulators, plugged restrictors, or leaks within the system can cause erratic performance. TAI recommends that the factory or an authorized representative be contacted before attempting any repairs to the sample or supporting gas systems within the analyzer.

5.5 Printed Circuit Board Descriptions

The electronics circuitry of the analyzer is designed with the latest integrated circuit technology. The individual circuits which are required to process the incoming signal and condition it to provide the various outputs, alarms, indicators, etc.,

5.5.1 Flame Guard and Anode Power Supply PCB

Schematic No.B-74672

Assembly Dwg. No.B-74671

Anode Power Supply: The high voltage anode power supply components are mounted on the flame guard and anode power supply printed circuit board. High voltage regulation is achieved through the use of zener diodes. The simplicity of this circuit's design can be attributed to the extremely low current demand of the anode circuit. The positive output voltage is nominally 125 volts. Output tolerance is ± 10 volts from the specified 250 volts, due to variation in components from unit to unit.

Flame Guard Circuit: A thermistor-controlled, comparator circuit is employed to operate relays in the event of a flame-out condition. A panel indicator light is turned on by the relay to alarm personnel that a flame-out condition has occurred.

The controlling thermistor is located within the upper section of the cell assembly. The electronic circuit components and relays are mounted on the same printed circuit board as the anode power supply, the indicator light on the control panel.

The thermistor is located in the circuit so that it controls the input of comparator. The circuit is factory set so that with the flame burning, the output of comparator is low. The microprocessor senses the low input and in turn sends 5VDC to turn on Q1, this holds the relay energized. When energized, the relay extinguishes the Flame Out indicator light. Conversely, if the flame goes out, bias to the switching transistor is lost, the relay drops out, and the Flame Out light receives power through normally closed contacts.

During ignition, the flame heats the thermistor, holding the relay in the energized condition and the indicator light off. If the Flame Out light comes on as the analyzer returns analyzing mode, then the flame is not burning, and the ignition procedure must be repeated.

5.5.2 Electrometer-Amplifier PCB

Schematic No. B79159

Assembly Dwg. No. B79153A

The ions formed in the process of burning hydrogen in the presence of hydrocarbon components of the sample gas cause an electrical conduction between two electrodes in the combustion chamber (or detector cell) that is amplified by a high sensitivity and high input impedance electrometer-amplifier circuit. The electrical output of the electrometer-amplifier is directly proportional to the quantity of flame ionizable hydrocarbons present.

The electrometer amplifier PC board is located on the side of sample module, interconnected to the electronic circuitry by means of a single 8-pin cable, so that the ease of replacement of a board is maintained. The high input impedance requires a shield, or cover, which is removable for access, as well as a shielded input conductor. Interconnection with the collector is made by a coaxial cable.

Although the cable and fittings are intended for coaxial service, the cable is actually being used as a shielded single-conductor connection. The collector cable plugs into a coaxial connector on the electrometer amplifier PC board, which is located at the side of the sample module.

The circuit consists of an electrometer amplifier and an operational amplifier. It is a very high-gain, current-to-voltage converter circuit, having an input impedance measuring in the billions of ohms. It is static sensitive and highly susceptible to contamination, and special handling precautions must be taken.

Because of its high impedance, the input circuitry to the electrometer has had careful design consideration. The resistors (R2 and R3) in the input gain circuit (see schematic) are installed on Teflon-insulated standoffs, instead of directly to the printed circuit, to eliminate the possibility of leakage currents.

To eliminate any possibility of contamination of the insulating materials employed, the completed PC board is ultrasonically cleaned in laboratory grade alcohol. **Under no circumstances should the parts described be handled with bare fingers.** A freshly-scrubbed finger, stroked along one of the glass resistors, would deposit enough skin oil to completely upset the range division of the attenuator circuit.

Resistor R3 is a 1000 M Ω resistor used in the feedback circuit of the amplifier. R2 has a resistance of 10,000 M Ω and is used in series with the zero potentiometer slider. This circuit is used to nullify any offset signal introduced by the signal electrode. Trimmer P1 is used to nullify the offset signal generated by the electrometer amplifier.

The output of the circuit is standardized against gases with known hydrocarbon concentrations by zero and span calibration, so that the meter and/or recorder indicate the hydrocarbon concentration of the gas being used.

The positive and negative operating voltage required by the electrometer amplifier is furnished by a switching power supply circuit, mounting at the back panel of the Analyzer

The stability of the electrometer circuit can be tested as follows:

1. Disconnect the collector cable.
2. Place the analyzer in the auto range.
3. Adjust zero offset value so that the recorder reads at some point upscale, and record a 24 hour chart.

Appendix

A.1 Specifications and Initial Settings:

- Range(s):** Refer to Addendum and Testing Results in Appendix B.
- Power Requirements:** Refer to Addendum and Testing Results in Appendix B.
- Signal Output:** Two analog channels:
Channel 1: 0-1 VDC and isolated 4-20 mADC
Channel 2: 0-1 VDC and isolated 4-20 mADC
User configurable as: Benzene, other aromatics, Total HC, and Peak traces.
- Alarms:** Two Concentration Alarm 'C' Type relay contacts. User configurable.
One System Alarm for AC power failure and flame out, fail safe, 'C' type relay contacts.
- Calibration Contact:** Calibration Contact, 'A' Type Relay contact for span mode indication.
- RS-232 Output:** Provided
- Ambient Temp:** 0 – 40° C. Install in a well ventilated area

A.2 Recommended Spare Parts List

Qty.	P/N	Description
1	B74671A	PC board, Flame guard & anode power supply
1	B79153A	PC board, Electrometer
1	C75825A	Micro-processor PC board
1	CP2540	Coaxial cable
1	B79154	Sensor Assy.
1	C62371A	Display PCB Assy.
1	B74674A	Interface to Motherboard PCB Assy.
1	C65507A	Backpanel/Power Supply PCB Assy.
1	F77	Fuse, 6.25A (3 AG)
1	L156	Lens, red
1	L154	LED, red
1	A33748	Thermistor assembly
1	V825	10 Port Switching Valve with Actuator, Electronic Control, and Power Supply
1	CP2408	PID temperature controller
1	T1403	Thermocouple, Type-K
1	G481	Pressure Gauge, 0-15psig

IMPORTANT: Orders for replacement parts should include the part number and the model and serial number of the system for which the parts are intended.

Send orders to:

TELEDYNE INSTRUMENTS

Analytical Instruments

16830 Chestnut Street
City of Industry, CA 91748

Telephone: (626) 934-1500

Fax: (626) 961-2538

Web: www.teledyne-ai.com

or your local representative.

Email: ask_tai@teledyne.com



A.3 Drawing List

(Refer to the *Addendum and Testing Results* section of Appendix B for actual drawing list for your application.)

D77394	Outline Diagram
D77488	Wiring Diagram
C76068	Piping Diagram
B79159	Schematic, Electrometer PCB
B74672	Schematic, Flame Guard, Anode Power Supply PCB
D-65506	Schematic, Back Panel/Power Supply PCB
B79154	FID Electrode Sub Assy.
D79158	FID Sensor Assembly

PC Board Assemblies

B74671	PCB Assy, Anode Power Supply, Flame Guard
B79153A	PCB Assy, Electrometer
C-75825	PCB Microprocessor
C-65507	PCB Power Supply

Appendix B

B1 Addendum and Testing Results