

INSTRUCTION MANUAL

MODEL 275

PORTABLE, LINE VOLTAGE OPERATED

THERMAL CONDUCTIVITY ANALYZER

TELEDYNE ANALYTICAL INSTRUMENTS
16830 Chestnut Street
City of Industry, Ca 91749-1580
Phone: (818) 961-9221
TWX: (910) 584-1887 TDYANYL COID

TABLE OF CONTENTS

SPECIFICATIONS	i
1.0 INTRODUCTION.	1
1.1 General Information.	1
1.2 Thermal Conductivity	1
1.3 Electrical Component Description	2
1.4 Analyzer Housing	2
2.0 CONTROLS AND DISPLAY.	3
2.1 Function Switch.	3
2.2 Zero Control	3
2.3 Span Control	3
2.4 Neon Indicator	3
2.5 The Flowmeter.	4
2.6 Analog Meters.	4
3.0 INSTALLATION.	5
3.1 Location	5
3.2 Electrical Connections	5
3.3 Gas Connections.	5
3.4 Pressure Regulation.	6
4.0 STARTUP	7
4.1 Preliminary.	7
4.2 Flowrates.	7
4.3 Calibration.	7
4.4 On Stream Operation.	7
5.0 MAINTENANCE	7
6.0 TROUBLE SHOOTING	8

RECOMMENDED SPARE PARTS

DRAWING LIST

1.0 INTRODUCTION

1.1 General Information

The Model 275 Line Voltage Operated Thermal Conductivity Analyzer measures the concentration of one component in a binary stream of gas, or the purity of a sample stream containing a composite mixture of impurities. It does this by comparing the difference in thermal conductivity of the sample stream with that of a reference gas of fixed composition (typically, air). Consult the Specifications Page to find the intended gas compositions and measurement ranges for which your instrument is designed and tested.

1.2 Thermal Conductivity

Thermal conductivity is a basic property of gases and vapors, and relates to their ability to conduct heat. Hydrogen and helium gases, being good conductors of heat, have a very high value of thermal conductivity, whereas low conductors of heat, e.g., gases like chlorine and carbon dioxide, have a very low thermal conductivity. This phenomenon forms the basic principle for the TAI Model 275 instrument, which is designed to measure a mixture of one gas in another in reference to a known, stable reference which represents the thermal conductivity of the non-measured component.

Thermal conductivity measurements are non-specific by nature. This fact imposes certain limitations and requirements. If the user intends to employ the analyzer to detect a specific component in a sample stream, the sample must be composed of the component of interest and one other gas in order to be accurate.

If, on the other hand, the user is primarily interested in the purity of a process stream, and does not require specific identification of the impurity, the analyzer can be used on more complex mixtures.

Because analysis by thermal conductivity is not an absolute measurement, standardizing gases of known composition will be required to fix the upper and lower parameters of the range (or ranges) of analysis. These gases will be used to periodically check the accuracy of the analyzer.

2.0 CONTROLS AND DISPLAY

2.1 Function Switch

This switch is used to select the gas mixture range to agree with the composition of the sample. Gas compositions for which your analyzer is intended will be specified on the specification page provided in the instruction manual which accompanies the instrument. Hydrogen and carbon dioxide (0-100% H₂ in CO₂), or carbon dioxide and air (0-100% air in CO₂), or Purity of Hydrogen (e.g. 100-80 % Hydrogen, 0-20 % Impurities), are the typical standard gas components and ranges; however, specially-ordered instruments will be designed according to the conditions specified by the purchaser. Single range instruments require no range switching and will have no function switch.

2.2 Zero Control

The zero potentiometer is used to adjust the zero reading. It operates on all ranges, but must be adjusted on the most sensitive range for the zero gas, i.e., 0-100% Air in CO₂.

2.3 Span Control

The span control potentiometer is used to adjust the meter to read the known concentration of a span gas present in the measurement cell (assuming that purging of previous cell content by the span gas has been accomplished.) See the Calibration Data Page for zero and span gas recommendations.

2.4 Neon Indicator

The neon indicator light is used to show when the instrument is switched ON. When this light starts flashing it indicates that the cell block has attained its constant temperature, and the proportional controller is switching the heater ON and OFF, so as to keep the cell temperature constant.

Generally the cell temperature is stable well within 30 minutes of switching on the analyzer.

3.0 INSTALLATION

3.1 Location

WARNING: THIS INSTRUMENT IS NOT EXPLOSION PROOF OR INTRINSICALLY SAFE AND MUST NOT BE USED IN A HAZARDOUS AREA.

The instrument should be installed where it will not be subjected to: direct sunlight; drafts from air; shock and vibration; temperatures below 30 Deg. F or above 110 Deg. F.

The analyzer should be placed as close as possible, subject to the above conditions, to the sample point to minimize the effects of sample line lag time on the analysis.

An outline diagram showing the location and identification of the gas and electrical connections, as well as the physical dimensions of the analyzer case, is included in the drawings at the rear of the manual.

3.2 Electrical Connections.

A source of single phase, 50 or 60 cycle, 110 to 120 volt power, capable of delivering 1 ampere of current continuously, is required to operate the analyzer. (220 volt optional upon special order.) The primary power connections are made by connecting the line cable to the plug at the back of the instrument.

Use 2-conductor shielded cable (nominally #22 ga. wire size) to interconnect the analyzer output signal with any recording equipment. The shield should be terminated on the appropriate terminal (see interconnection diagram) at the analyzer—and be left disconnected at the recorder.

3.3 Gas Connections

Customer gas connections are provided for the measurement gas hose connector at the side of the instrument. One fitting for the sample intake and another one for the sample outlet.

3.3.1 Gases

100% CO₂ should be used as the zero gas. 100% H₂ should be used as the span gas. The instrument is zeroed on the air in CO₂ range, and spanned on the 100-80% H₂ in air range.

WARNING: THE HYDROGEN MIXTURE IS A HIGHLY EXPLOSIVE GAS. CARE SHOULD BE TAKEN NOT TO STORE IT NEAR FLAMES OR INFLAMMABLE MATERIALS. ALSO, THE OUTPUT FROM THE CELL SHOULD BE PURGED TO A REMOTE SPACE, AWAY FROM IGNITION SOURCES.

4.0 STARTUP

4.1 Preliminary

4.1.1 Check that all lines have been connected to the proper ports of the analyzer, and that all the lines are leak free.

4.1.2 Plug the power cord in.

4.1.3 Turn the analyzer power switches ON.

4.1.4 Allow the analyzer to warm up after switching it on until the lamp starts flashing, then add 15 more minutes warm-up.

4.2 Flowrate

The measurement gas flowrate should be approximately .3 scfh, at 10 psi pressure.

4.3 Calibration

1. Adjust the zero control to zero on the meter scale in Range 1 of the instrument, with 100% CO₂ flowing through the cell.
2. Adjust the span control to fullscale output in Range 2 with 100% H₂ flowing through the cell.
3. Lock the zero and span controls and switch to Range 3.
4. Check the zero setting on Range 3, with 100% CO₂ flowing through the cell.
5. Check the zero and span settings for the other ranges. They should be at the correct settings. If not, some minor internal adjustments need to be made - contact TAI.

After calibration has been successfully concluded, connect the sample gas to the analyzer, and adjust the flow to approximately 0.2 scfh.

5.0 MAINTENANCE

Since no moving parts are used in the analyzer, no routine maintenance is required, other than checking the flow rate of measurement gas periodically.

Model 275
Linearity Charts

Range I
0-100%
CO₂ in Air

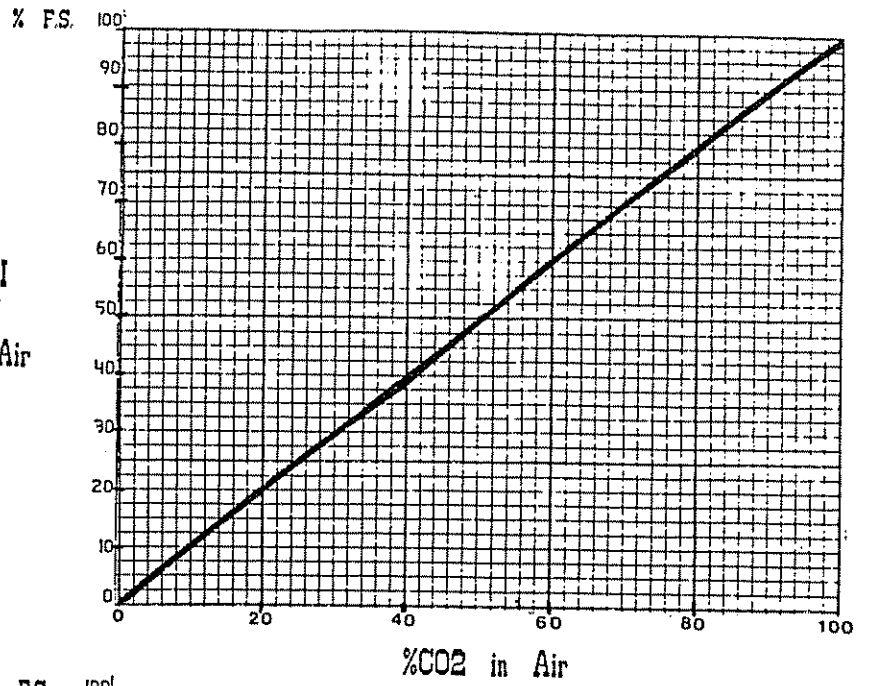

Range II
100-80%
H₂ in Air

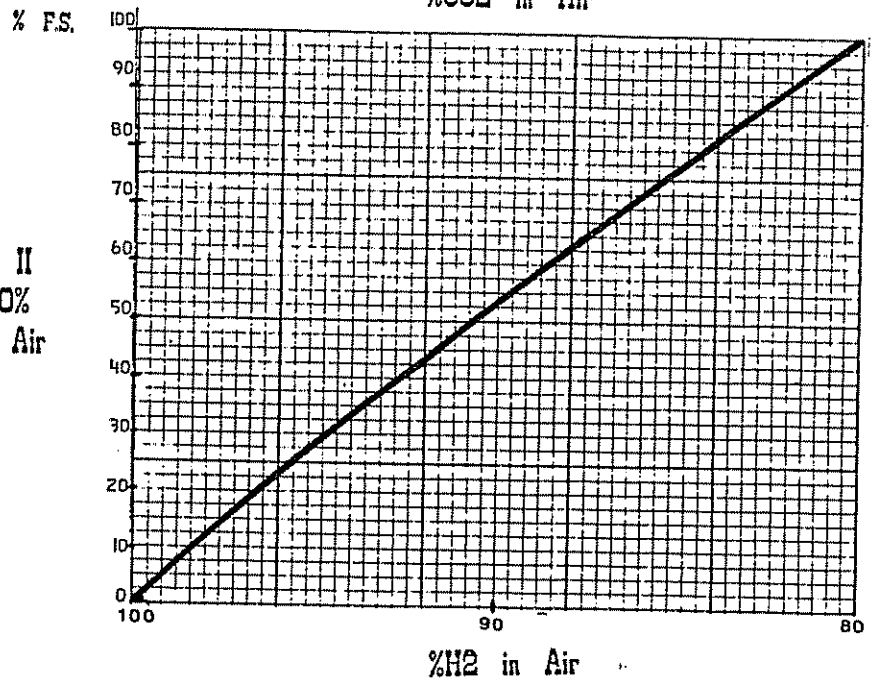

Range III
0-100%
H₂ in CO₂

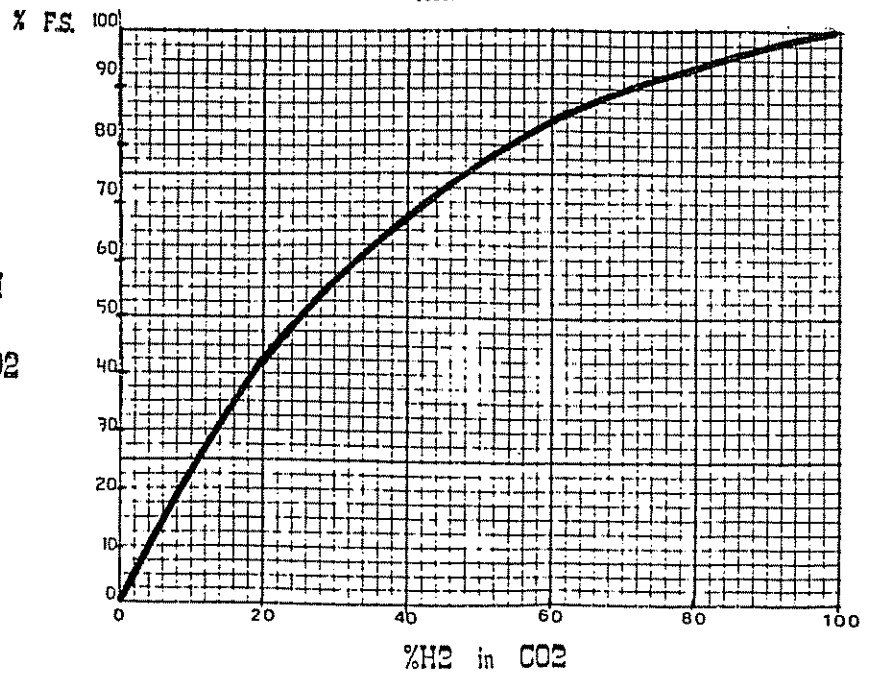

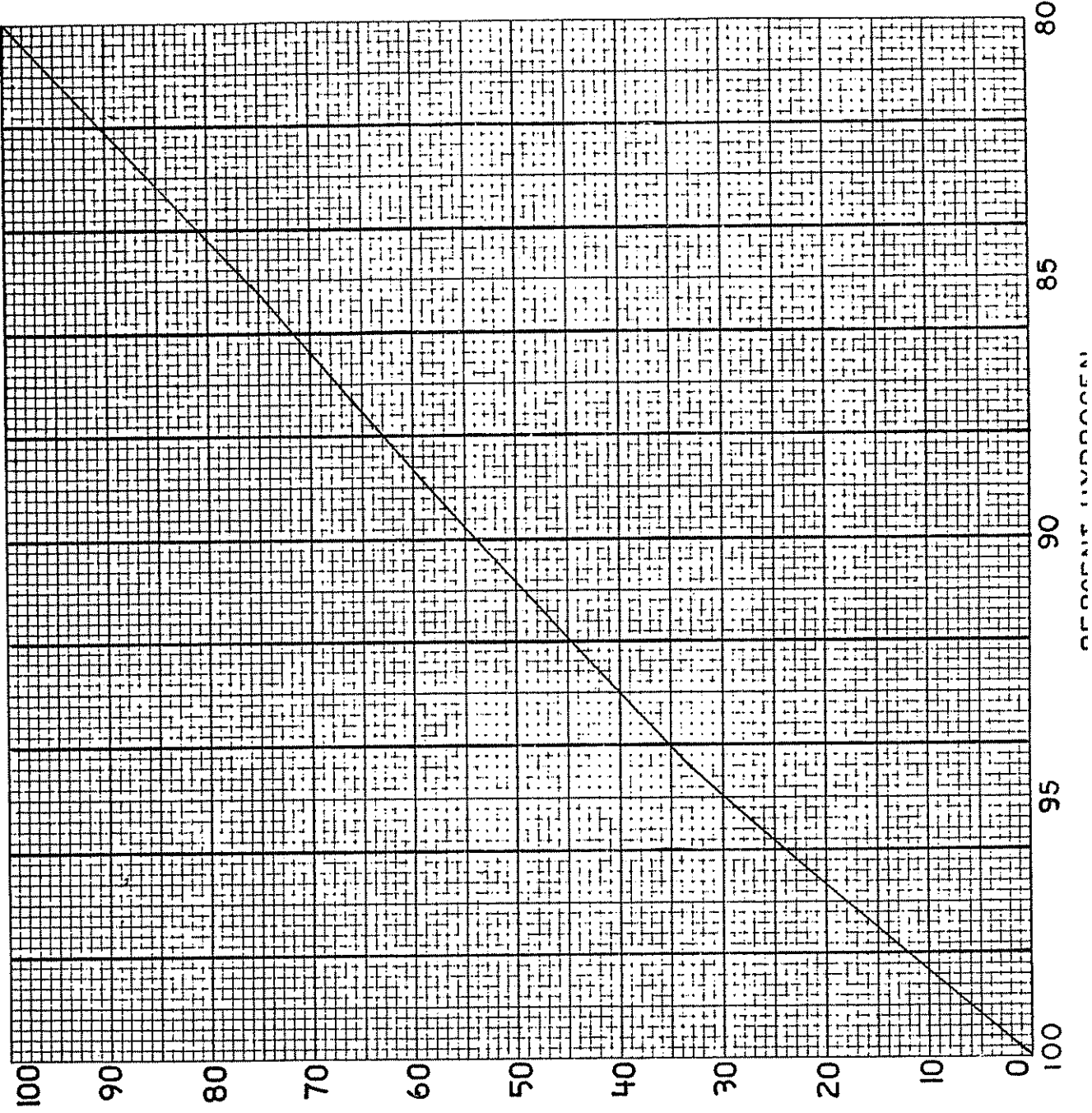

MDL.: 275

RANGE: 100 - 80% H₂ IN AIR

OUTPUT: 0 1VDC

PERCENT OF FULL SCALE/RECORDER READING

RECOMMENDED SPARE PARTS LIST

MODEL 275

<u>QTY.</u>	<u>P/N</u>	<u>DESCRIPTION</u>
F-9	5	Fuse, 1 amp
H-158	1	Heater, 18 watt cartridge type
B-30866	1	Power Supply/Amplifier, P.C. Board Assembly
A-9306	1	Differential Power Supply
C-30803	1	Mother Board Sub Assembly
M-41	1	Meter
P-156	1	Span Pot, 10 kilohms, 10 turns
P-63	1	Zero Pot, 500 ohms, 10 turns
F-133	1	Flowmeter
F-288	1	Main Transformer
B-31186	1	Connector Block, Sub-Assembly (sample)
A-31157	1	Cell Block, Sub Assembly

* - THESE ITEMS ARE OPTIONS TO THE STANDARD INSTRUMENT, AND UNLESS ORDERED, WILL NOT BE PRESENT.

A MINIMUM CHARGE OF \$ 20.00 IS APPLICABLE TO SPARE PARTS ORDERS.

IMPORTANT: Orders for replacement parts should include the part number (if available) and the model and serial number of the system for which the parts are intended.

SEND ORDERS TO :

TELEDYNE ANALYTICAL INSTRUMENTS
16830 CHESTNUT STREET
CITY OF INDUSTRY, CALIF., 91748
TELEPHONE (818) 961-9221
TWX: (910) 584-1887 TDYANYL COID
OR YOUR LOCAL REPRESENTATIVE

ISSUE NO.	DATE	REVISION / ECO NUMBER	APP.
1.			
2	5-29-85	ADDED VIEW AA	TK

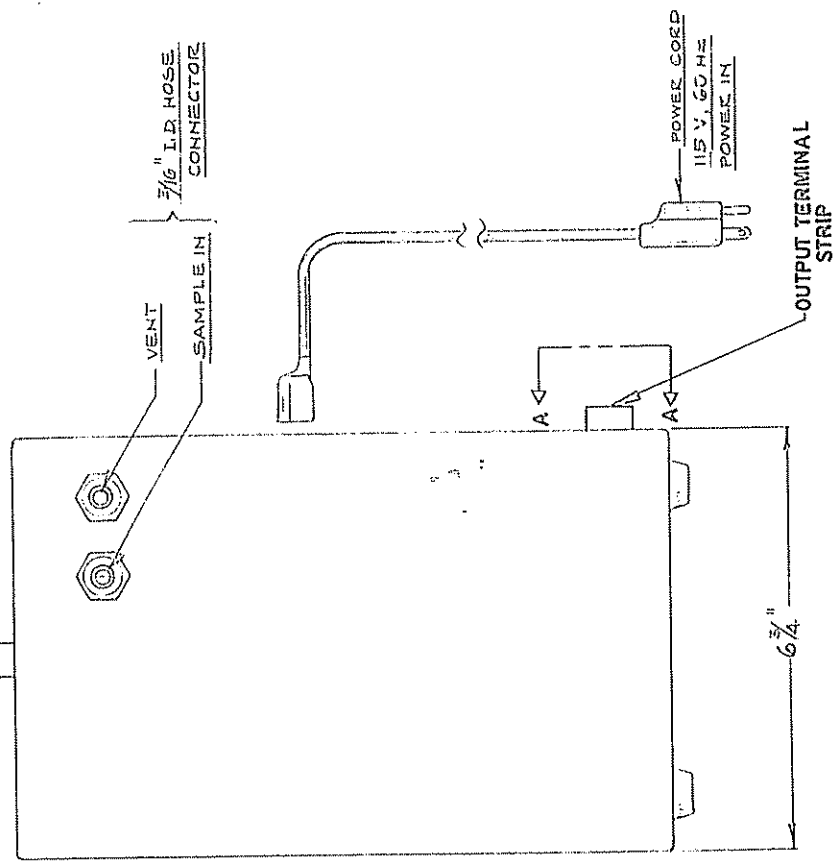
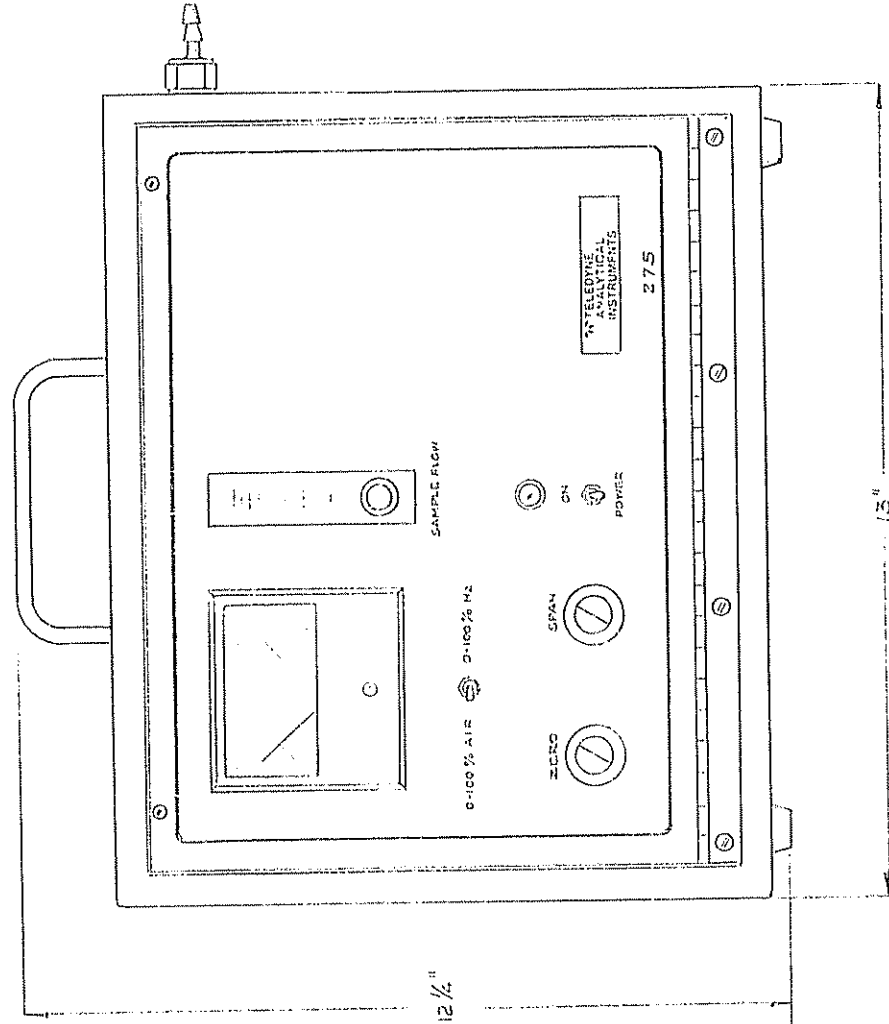

ITEM	PART NO.	REQ.	DESCRIPTION
TOLERANCE UNLESS OTHERWISE SPECIFIED			THIS DRAWING IS THE PROPERTY OF TELEDYNE ANALYTICAL INSTRUMENTS AND CONTAINS CONFIDENTIAL INFORMATION. IT IS NOT TO BE COPIED, REPRODUCED OR USED WITHOUT WRITTEN PERMISSION.
FRAC. 1/64			SCALE 1:2 DATE 5-17-85
DEC. 005			MAT'L
ANGULAR °			FINISH
			OR 4 ENGRS. JAB/A
			B-31198
			S.O.

VIEW-A
SCALE-NONE

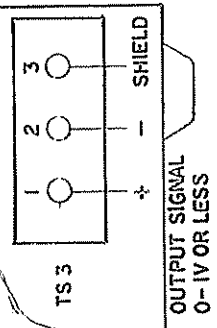

ISSUE NO.	DATE	REVISION	ECO NUMBER	APP
1	1-1-90	INITIAL RELEASE		
2	6-1-90	UPDATES TO T/C AND CONFIGURATION		JH

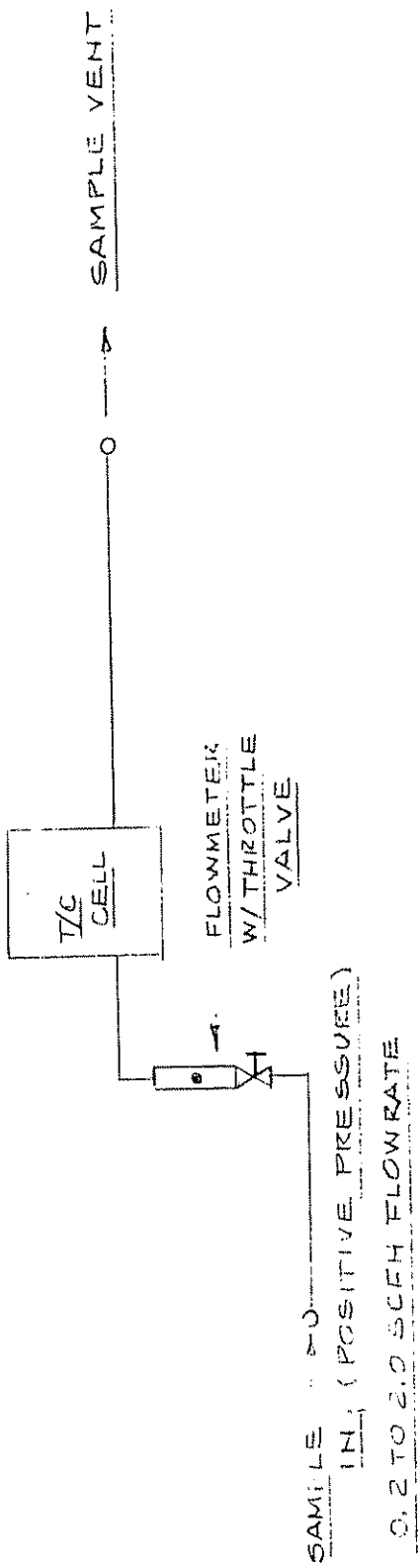

ITEM	PART NO.	REQ	DESCRIPTION
THIS DRAWING IS THE PROPERTY OF TELEDYNE ANALYTICAL INSTRUMENTS AND CONTAINS CONFIDENTIAL INFORMATION. IT IS NOT TO BE COPIED, REPRODUCED OR USED WITHOUT WRITER'S PERMISSION.			
FRAC 1/64"			TELEDYNE ANALYTICAL INSTRUMENTS CITY OF INDUSTRY CALIFORNIA 91748
DEC 005			PORTABLE T/C ANALYZER
ANGULAR 1/2			MDL 275 PIPING SCHEMATIC
			SCALE: --- DATE: 3-17-83
			MAT L: ---
			FINISH: ---
			DR: --- ENGR: --- APPR: ---
			A-31199
			S.O.

ISSUE NO.	APP.
2) 89-0125	12
SEE REV CARD	11
3) 1-25-84	10
TERM 10, WAS 6	9
4) 6-23-84	8
ADDED NOTES	7
5) 4- - 85	6
ECO# 85-0178	5
6) 10-25-85	4

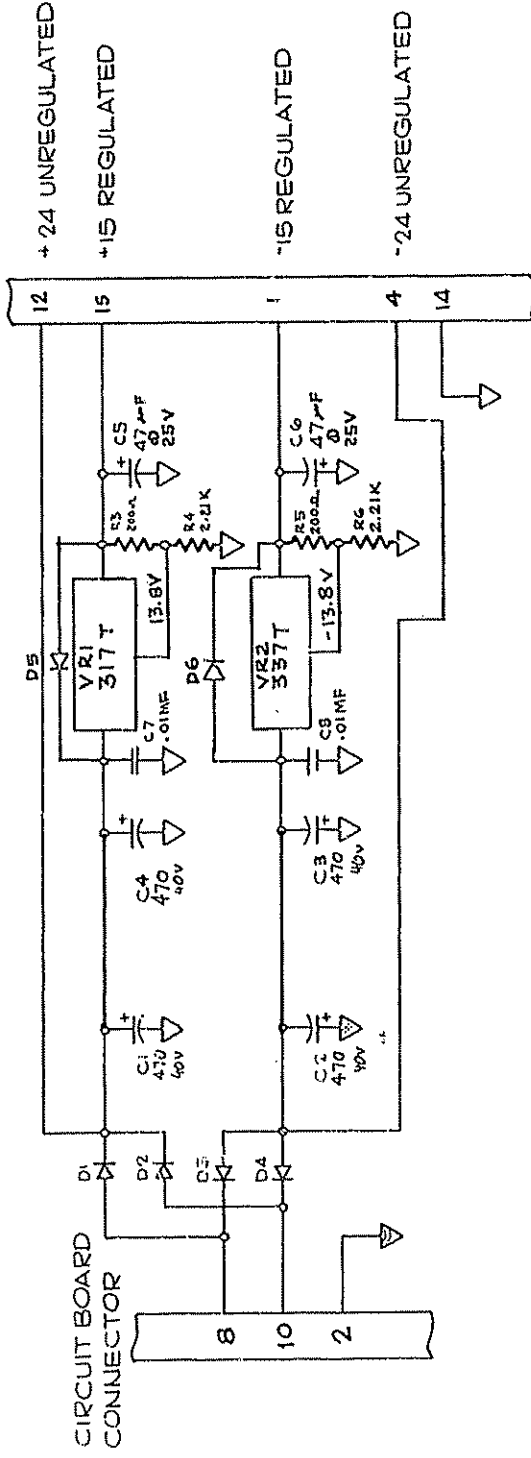

NOTE: UNLESS OTHERWISE SPECIFIED,
 ALL RESISTANCE VALUES ARE IN OHMS.
 ALL CAPACITANCE VALUES ARE IN MICRO-FARADS.
 ALL DIODES ARE IN4004.

CIRCUIT BOARD
 CONNECTOR

THIS DRAWING IS THE PROPERTY OF TELEDYNE ANALYTICAL INSTRUMENTS AND CONTAINS CONFIDENTIAL INFORMATION. IT IS NOT TO BE COPIED, REPRODUCED OR USED WITHOUT WRITTEN PERMISSION.	
FRACT. ± 1/64	DEC. ± .003
TELEDYNE ANALYTICAL INSTRUMENTS SAN GABRIEL, CALIFORNIA	SCALE: 1" = 1"
REGULATED POWER SUPPLY SCHEMATIC	DATE: 8-22-83
ASSY/A9506	FINISH: ~
	DR: ~ ENGR: ~ APP: ~
	B-33129

ISSUE NO	DATE	REVISION	ECO NUMBER	APP
3	3-5-84		ECO# 84-0037	SAE
4	4-11-86		ADD IN4004 DIODE FOR 220V OPTION	W
5	5-7-87		ECO# 87-0033	W

NOTES
 ALL RESISTORS 1/8 W, 1% UNLESS OTHERWISE NOTED.
 SELECTED PER APPLICATION - SEE TABLE BELOW
 FOR 220V USE 20K, 5W, 5% (CR 1023)
 INSTALL IN4004 DIODE (C589) IN PLACE OF STRAP

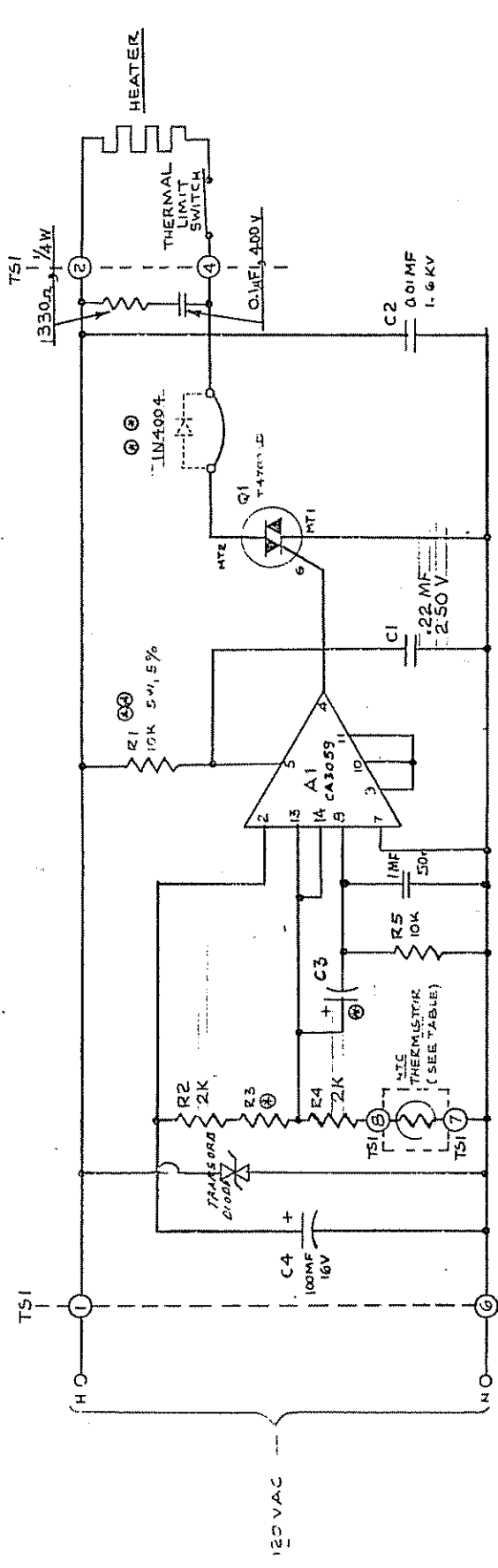

MDL	TEMP. SET PT.	TEMP. LIMIT
B10X	110°F (43°C)	130°F (54°C)

B-30921 ASS'Y

CONTROL TEMP °C ± 3°C	R3 (kΩ) *	P/N	C3 (µF) *	P/N	R3 (kΩ) **	P/N	C3 (µF) **	P/N
30	13	R558	10	C339				
41	8.25	R388	10	C339	5.62	R718	22	C348
43	7.50	R406	10	C339	5.23	R532	22	C348
46	6.81	R400	22	C348	4.64	R548	22	C348
50	5.40	R383	22	C348	4.02	R452	56	C259
55	4.75	R719	22	C348	3.40	R480	56	C259
60	4.02	R452	56	C259	2.94	R581	56	C259
64	3.57	R634	56	C259	2.49	R456	56	C259

* WITH 16K CONTROL THERMISTOR T172
 ** WITH 10K CONTROL THERMISTOR T174

ITEM	PART NO	REQ	DESCRIPTION
TOLERANCE UNLESS OTHERWISE SPECIFIED			
THIS DRAWING IS THE PROPERTY OF TELEDEYNE ANALYTICAL INSTRUMENTS AND CONTAINS CONFIDENTIAL INFORMATION. IT IS NOT TO BE REPRODUCED OR DISSEMINATED WITHOUT WRITTEN PERMISSION.			
FRAC	1-84		TELEDEYNE ANALYTICAL INSTRUMENTS CITY OF INDUSTRY CALIFORNIA 91748
DEC	005		SCALE
ANGULAR	4		DATE 3-10-83
PROPORTIONAL TEMP CONTROL			
P.C. BOARD			
SCHEMATIC			
FINISH			
DR 4 INGR JAE APP WAA			
B-31077			

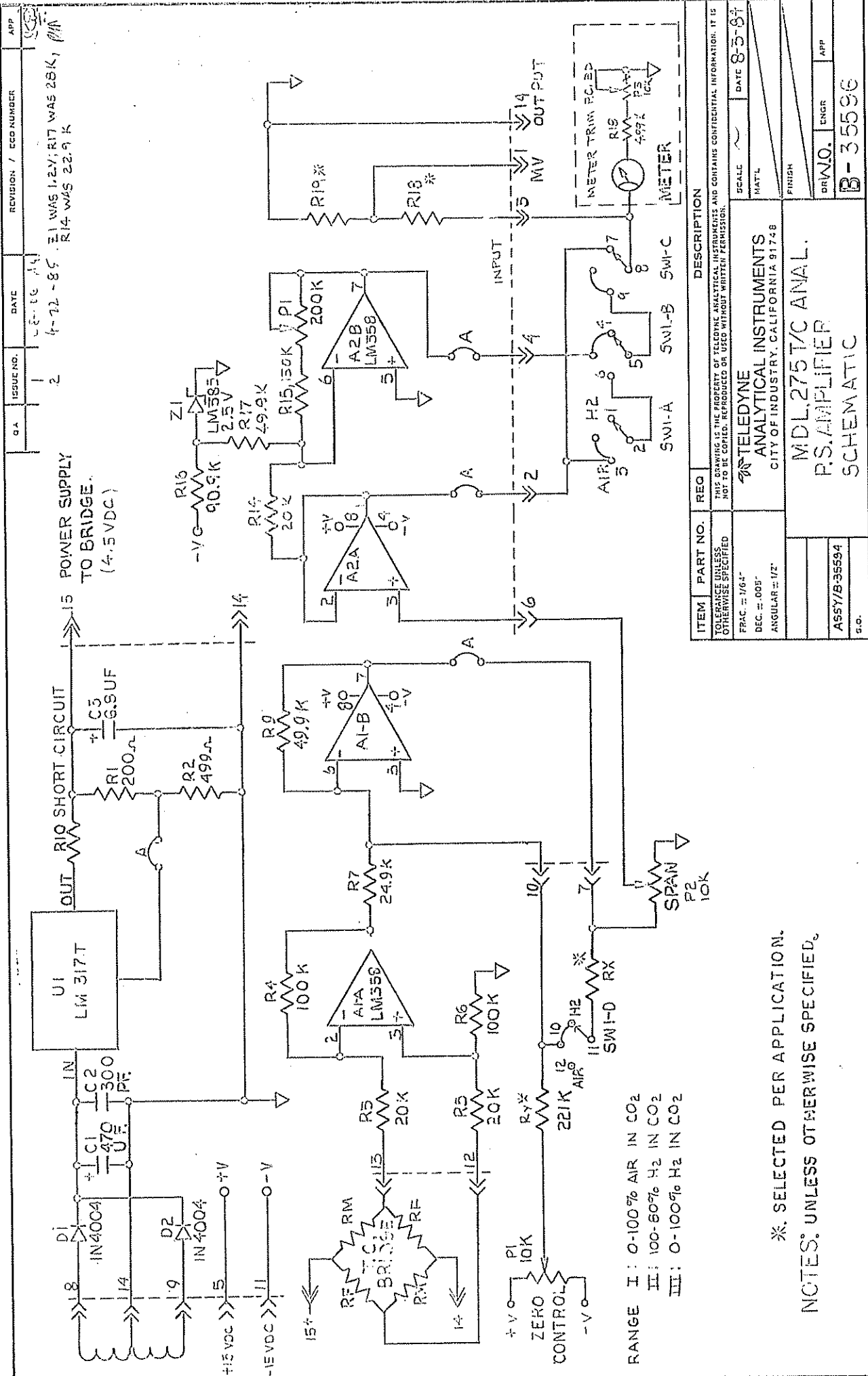

REVISION / ECO NUMBER
 1
 2

DATE
 4-22-85

APP
 E1 WAS 1.2V; R17 WAS 28K; R14 WAS 22.9K

POWER SUPPLY TO BRIDGE (4.5 VDC)

OUT R10 SHORT-CIRCUIT

IN

REF

CONTROL

INPUT

OUTPUT

METER

METER TRIM P.C.B.

SCALE

MAT'L

FINISH

DRW'G. ENGR. APP.

B-35596

DATE 8-5-87

DESCRIPTION

TELEDYNE ANALYTICAL INSTRUMENTS CITY OF INDUSTRY, CALIFORNIA 91748

MDL 275 T/C ANAL. P.S. AMPLIFIER SCHEMATIC

ITEM PART NO. REQ

TOLERANCE UNLESS OTHERWISE SPECIFIED

FRAC. = 1/64"

DEC. = .005"

ANGULAR ± 1/2°

ASSY/B-35594

S.O.

NOTES: UNLESS OTHERWISE SPECIFIED, *

RANGE I: 0-100% AIR IN CO2

RANGE II: 100-60% H2 IN CO2

RANGE III: 0-100% H2 IN CO2

© BEKOP GRAPHICS/ACUPRESS REORDER NO. 42278