

---

# INSTRUCTION MANUAL

## MODEL 306WA

### TRACE OXYGEN ANALYZER

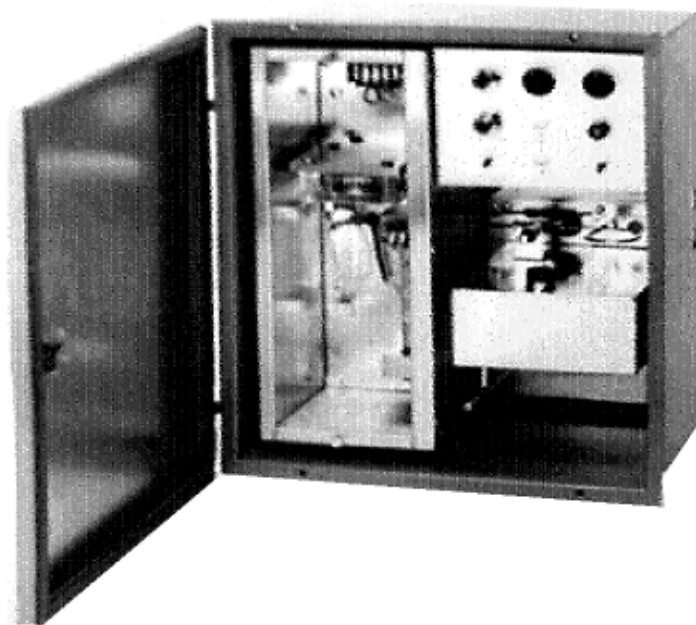

#### **DANGER**



HIGHLY TOXIC AND OR FLAMMABLE LIQUIDS OR GASES MAY BE PRESENT IN THIS MONITORING SYSTEM.

PERSONAL PROTECTIVE EQUIPMENT MAY BE REQUIRED WHEN SERVICING THIS SYSTEM.

HAZARDOUS VOLTAGES EXIST ON CERTAIN COMPONENTS INTERNALLY WHICH MAY PERSIST FOR A TIME EVEN AFTER THE POWER IS TURNED OFF AND DISCONNECTED.

ONLY AUTHORIZED PERSONNEL SHOULD CONDUCT MAINTENANCE AND/OR SERVICING. BEFORE CONDUCTING ANY MAINTENANCE OR SERVICING CONSULT WITH AUTHORIZED SUPERVISOR/MANAGER.

P/N M4624  
09/14/99  
ECO# 99-0373

## Copyright © 1999 Teledyne Electronic Technologies/Analytical Instruments

All Rights Reserved. No part of this manual may be reproduced, transmitted, transcribed, stored in a retrieval system, or translated into any other language or computer language in whole or in part, in any form or by any means, whether it be electronic, mechanical, magnetic, optical, manual, or otherwise, without the prior written consent of Teledyne Electronic Technologies/Analytical Instruments, 16830 Chestnut Street, City of Industry, CA 91749-1580.

## Warranty

This equipment is sold subject to the mutual agreement that it is warranted by us free from defects of material and of construction, and that our liability shall be limited to replacing or repairing at our factory (without charge, except for transportation), or at customer plant at our option, any material or construction in which defects become apparent within one year from the date of sale, except in cases where quotations or acknowledgements provide for a shorter period. Components manufactured by others bear the warranty of their manufacturer. This warranty does not cover defects caused by wear, accident, misuse, or neglect. We assume no liability for direct or indirect damages of any kind and the purchaser by the acceptance of the equipment will assume all liability for any damage which may result from its use or misuse.

We reserve the right to employ any suitable material in the manufacture of our apparatus, and to make any alterations in the dimensions, shape or weight of any parts, in so far as such alterations do not adversely affect our warranty.

## Important Notice

This instrument is intended to be used a tool to gather valuable data. The information provided by the instrument may assist the user in eliminating potential hazards caused by the process that the instrument is intended to monitor; however, **it is essential that all personnel involved in the use of the instrument or its interface with the process being measured be properly trained in the process itself, as well as all instrumentation related to it.**

The safety of personnel is ultimately the responsibility of those who control process conditions. While this instrument may be able to provide early warning of imminent danger, it has no control over process conditions, and can be misused. In particular, any alarm or control system installed must be tested and understood, both as they operate and as they can be defeated. Any safeguards required such as locks, labels, or redundancy must be provided by the user or specifically requested of Teledyne.

The purchaser must be aware of the hazardous conditions inherent in the process(es) he uses. He is responsible for training his personnel, for providing hazard warning methods and instrumentation per the appropriate standards, and for ensuring that hazard warning devices and instrumentation are maintained and operated properly.

Teledyne Electronic Technologies/Analytical Instruments, the manufacturer of this instrument, cannot accept responsibility for conditions beyond its knowledge and control. **No statement expressed or implied by this document or any information disseminated by the manufacturer or his agents is to be construed as a warranty of adequate safety control under the user's process conditions.**

## Table of Contents

<b>1 Introduction</b>	
1.1 Method of Operation .....	1-1
1.2 Required Equipment .....	1-2
1.2.1 Sample Conditioning .....	1-2
1.2.2 Recorder /Meter Readout .....	1-2
<b>2 Operational Theory</b>	
2.1 Sensor .....	2-1
2.2 Humidifier .....	2-1
2.3 Flow System .....	2-2
2.4 Calibrator .....	2-4
<b>3 Installation</b>	
3.1 Location .....	3-1
3.2 Electrical Connections .....	3-1
3.3 Sample Connections .....	3-2
<b>4 Operations</b>	
4.1 Filling the Reservoir .....	4-1
4.2 Detector Cell .....	4-1
4.2.1 Cell Packaging .....	4-1
4.2.2 Electrolyte .....	4-1
4.2.3 Cell Installation .....	4-3
4.3 Calibrator .....	4-5
4.4 Throttle Valve .....	4-5
4.5 Humidity Control .....	4-7
4.6 Power .....	4-8
4.7 Warm-Up and Stabilization .....	4-8
4.7.1 Calibration .....	4-8
<b>Maintenance &amp; Troubleshooting</b>	
5.1 Flowmeter and Humidifier .....	5-1
5.2 Cell Electrolyte Level .....	5-1
5.3 Reservoir .....	5-1

5.4	Calibration .....	5-2
5.4.1	Internal Calibrator .....	5-2
5.4.2	Standard (span) Gas Calibration .....	5-2
5.5	Cell .....	5-4
5.5.1	Electrolyte Replacement .....	5-4
5.5.2	Lead Electrode .....	5-5
5.6	Screen Assembly .....	5-5
5.7	Calibrator .....	5-6
5.8	Reservoir and Humidifier Column .....	5-6
5.9	Leak Detection .....	5-8
5.9.1	Leak Detection Procedure .....	5-8
5.9.2	Cell Leak .....	5-9

**Appendix**

	Specifications .....	A-1
	Spare Parts List .....	A-2
	Drawing List .....	A-3
	Calibration Data .....	A-4

## **Introduction**

---

The Teledyne Analytical Instruments Model 306WA Trace Oxygen Analyzer is designed to detect trace concentrations of oxygen in process streams. It utilizes Teledyne's patented electrochemical sensor which requires minimal maintenance and exhibits a 90% response in less than one minute. Cell output is insensitive to flow rate changes within the operating range of the analyzer's flowmeter.

The Model 306WA features a welded stainless sampling system for long-term, leak-free operation.

While the analyzer is offered in several configurations, they are virtually identical with the exception of housing or options such as special meters. For purposes of clarity, this manual will discuss the unit in general, since differences will be minor and will be obvious to the user.

### **1.1 Method of Operation**

Gas from the process stream is fed through a sample line to the sample inlet port of the analyzer. The sample is directed through the analyzer's sample system, where oxygen concentration is detected by the sensor. The sensor generates an output signal which is read out on a suitable recorder or meter.

The analyzer components include a throttle valve and flowmeter to control sample flow, a humidifier to condition the sample, the measuring cell and its associated circuitry, and a calibrator to adjust the sensitivity of the analyzer to the desired measurement range.

### **1.2 Required Equipment**

For proper operation, the analyzer may require accessory equipment, particularly in the area of sample conditioning. The need for additional equipment is dictated by the conditions of each application.

### 1.2.1 Sample Conditioning

The sample should be free of entrained solids and condensable vapors, and be at a relatively constant pressure between **1 and 100 psig**. However, more efficient operation is obtained with pressures in the range of **5 to 10 psig**. Pressure surges can carry fluid from the humidifier into the cell and impair cell operation. Filters, scrubbers, or pressure regulators are often necessary, depending on local conditions.

- 1. Filters.** If filters are necessary, they should be conveniently located near the analyzer, and installed in a fashion which permits easy removal for periodic cleaning or replacement.
- 2. Scrubbers.** If the sample contains small quantities of acidic anhydrides (SO<sub>2</sub>, etc.) or mercaptans (H<sub>2</sub>S, etc.) they will react with the electrolyte or the cathode, and for consistent operation should be removed. A caustic scrubber is usually effective.
- 3. Pressure regulators.** While the analyzer will accept pressures to 100 psig, a range of **5 to 10 psig** is recommended. In addition, pressure surges can affect instrument operation. In either case, the use of a pressure regulator is advisable. Install the regulator as close to the sample point as possible to reduce sample travel time to a minimum. The regulator should incorporate a metallic diaphragm to prevent the diffusion of atmospheric oxygen into the sample.

### 1.2.2 Recorder /Meter Readout

The meter installed on the 306WA is either analog or digital. The recorder used for analyzer signal readout is usually of the self-balancing potentiometric type. It should have an input impedance of **20 KΩ** or higher for the 0 to 1 VDC (or optionally less than 0-1 VDC) signal output, and 4-20 mADC isolated ground (standard) for maximum load resistance of **1.0 KΩ**.

---

## Operational Theory

---

### 2.1 Sensor

The sensor is an open-cathode cell, an electrochemical transducer specific to oxygen. The cathode of the cell is composed of silver screen elements with a large surface area. The screen assembly is mounted in an acrylic block, with the lower edges of the screens immersed in potassium hydroxide electrolyte. A thin layer of electrolyte is maintained on the surfaces of the screens by capillary action. A lead disk is positioned under the screens and serves as the anode.

The sample gas stream is passed directly over the cathode screens, initiating an electrochemical reaction. Four electrons are generated by the oxidation of the lead anode, and are then used to reduce oxygen at the cathode. The flow of electrons between the anode and cathode creates an electric current which is directly proportional to the oxygen concentration in the sample stream. In the absence of oxygen, no oxidation or reduction takes place, and no current is produced.

In simplified form, the reaction may be described as follows: oxygen is reduced at the cathode by the mechanism

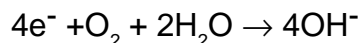

This cathodic half-reaction occurs simultaneously with the anodic half-reaction



The overall reaction is

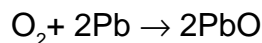

### 2.2 Humidifier

It is necessary to maintain a film of electrolyte on the screens of the electrode assembly. This means that the humidity of the sample as it flows through the cell must be such that the water vapor pressure of the electro-

lyte is equal to the water vapor pressure in the sample gas. If the humidity of the sample is too low, water will evaporate from the electrolyte, drying the cell. If the sample humidity is too high, water will condense out into the electrolyte, flooding the cell.

The sample is humidified by bubbling it through water in the humidifier column just before it enters the cell. The humidifier column is in the same heated compartment as the cell and so is held at the same temperature. The water in the column, however, is cooled by evaporation into the sample gas. Thus, the sample gas will normally have a humidity that is too low for equilibrium with the cell. It is assumed here, of course, that since the cell component is heated above ambient temperature, the sample gas is less than saturated at the compartment temperature when it enters the analyzer.

The humidity of the sample is increased to be in equilibrium with the cell electrolyte by heating the water in the humidifier column. The humidifier heater is in the base of the column, and the amount of heating is adjusted with the humidity control that is located on the panel of the control unit.

The amount of heating required depends on the sample flow rate, the sample humidity, and the specific heat of the sample. The correct adjustment for the operating conditions of any particular installation is obtained by checking the cell electrolyte level periodically as described in section 4.2.3.

The humidifier column also contains baffles to stop water from splashing up into the line to the sample cell at high flow rates.

### **2.3 Flow System**

The analyzer flow system is shown schematically in Figure 1. It includes a needle valve for adjusting the sample flow rate, a flowmeter to indicate the sample flow required for calibration, the humidifier, the calibrator, the measuring cell, and an automatic level control system for the water in the humidifier.

As can be seen from Figure 1, the sample enters the humidifier column against the pressure of a water column from the base of the humidifier to the water level in the reservoir, which is approximately 4 inches. This determines the minimum sample pressure at which any sample can flow through the analyzer. In practice, the sample pressure must be somewhat greater than this in order to have an adequate flow rate.

The automatic level control in the humidifier column is accomplished by connecting the sample outflow from the cell to the bottom of the reservoir. This puts a back pressure on the sample in the cell and upper portion of



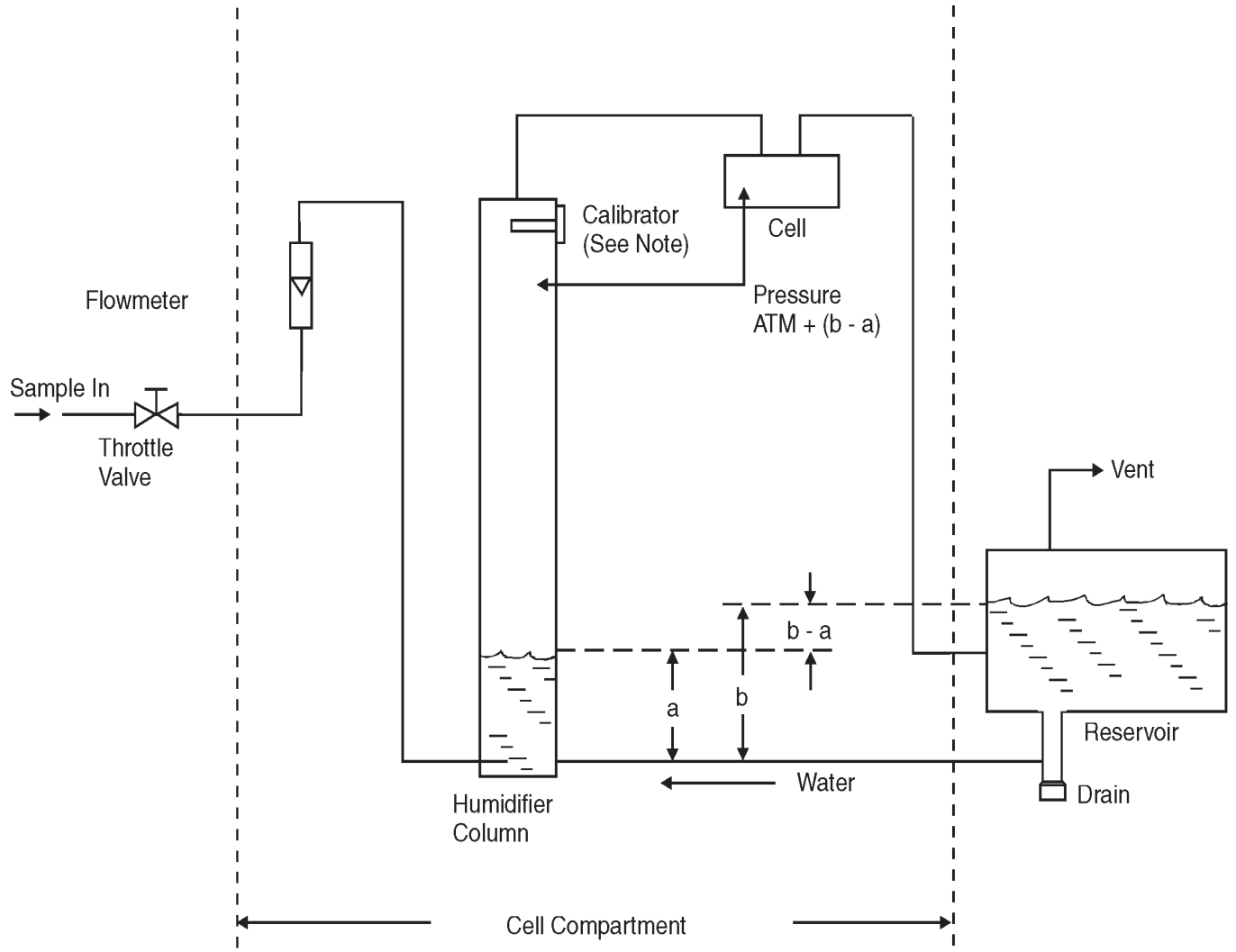

Figure 1: Flow System Schematic

the humidifier column equal to the water column from the bottom of the reservoir to the water level in the reservoir. Thus, the water level in the humidifier column is held even with the sample connection at the bottom of the reservoir. There will be a slight additional pressure in the top of the humidifier column depending on the flow rate (the pressure needed to push the sample through the cell and associated tubing), but at normal flow rates this merely slightly lowers the level in the humidifier column.

The sample bubbles through the water in the reservoir on its way to the outlet port. Some of the water vapor will re-condense, so that the sample flows out of the outlet port saturated at the reservoir temperature, which is slightly above ambient. The sample bubbling through the make-up water will scrub out any oxygen which may be dissolved in it. This assures that the sample will not pick up any oxygen as it passes through the humidifier column.

### 2.4 Calibrator

The number of electrons flowing through the measuring cell's load resistance (the output current) is directly proportional to the amount of oxygen that has reacted. If no oxygen is present, no output current flows, giving the analyzer an absolute zero. No zero adjustment is required. The analyzer can be completely calibrated with only one standard sample, instead of the two usually required for process analyzers.

If the oxygen content indicated by the analyzer is plotted as ordinate against the actual oxygen content as abscissa on a simple graph, the condition of proper calibration is represented by a straight line starting at the origin with a slope of 1 (see Figure 2). If the analyzer has a low sensitivity, the slope will be greater than 1. In each case, however, the line passes through the origin because of the absolute zero, and the slope is determined by the sensitivity adjustment. Thus, the analyzer can be completely calibrated by adjusting the slope of this curve; i.e., by adjusting the span so that the change in output indication is equal to a known change in actual oxygen content of the sample. This can be done by adding a known amount of oxygen to the sample flowing through the analyzer, even though the amount of oxygen in the sample is now known. Refer to section **4.7.1: Calibration**.

The calibrator provided is an electrolysis cell in which water is converted to hydrogen and oxygen by an electric current.

The concentration of oxygen added to the sample can be calculated from the amount of current passing through the calibrator and the sample flow rate.

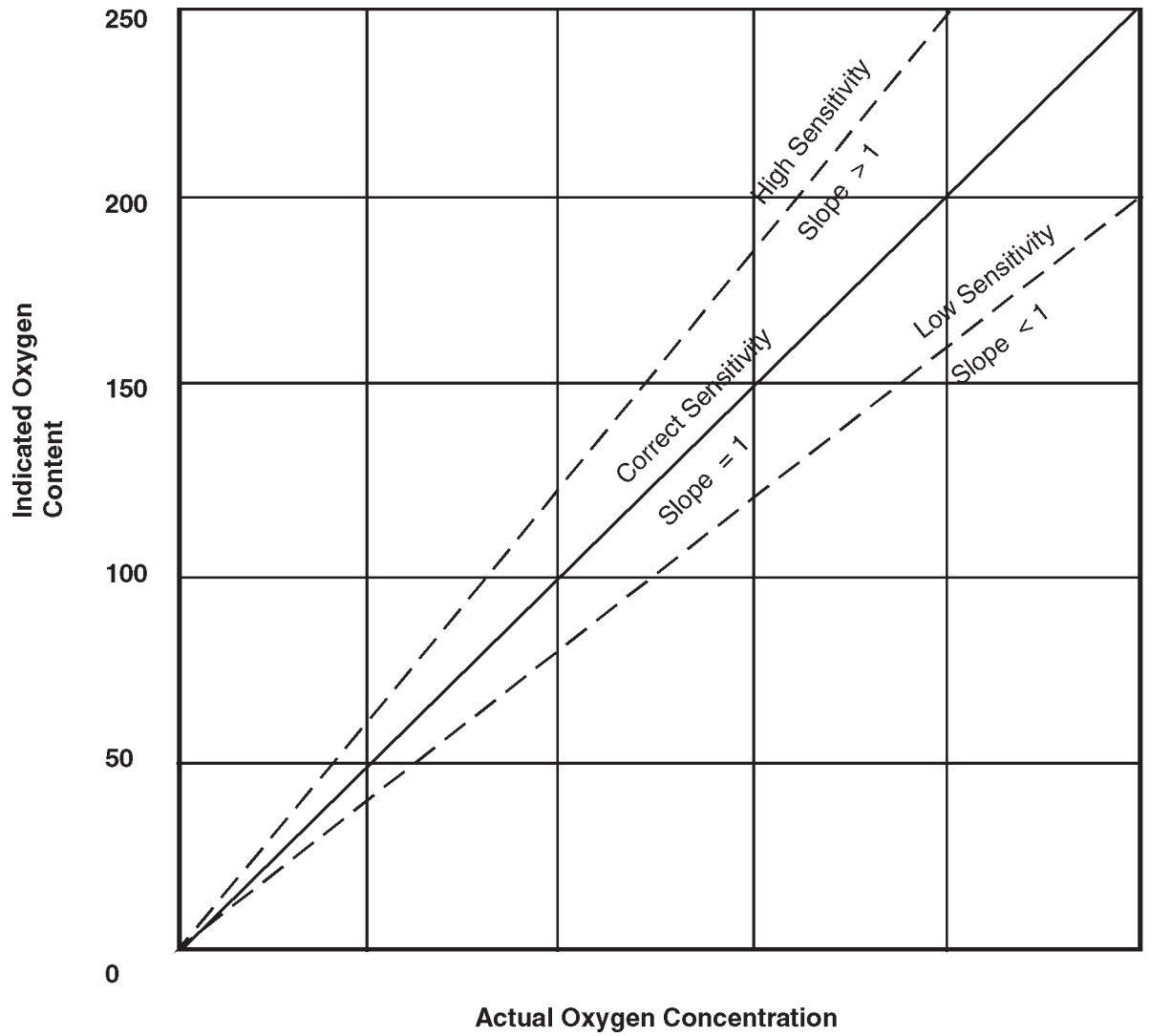

Figure 2: Proper Calibration

The three ranges of the analyzer are intended primarily to make calibration convenient. It is expected that the oxygen content of the sample being analyzed will be within the narrow range (Range No. 1) of the analyzer. Then when the analyzer is switched to Range No. 2, a sufficiently large amount of oxygen can be added by the calibrator to give a reliable calibration. Since the calibration is dependent on adjusting the change in indication, this change should be as large as possible—at least 50% of the wider range.

For example:

Analyzer range: 0-1, 0-100, 0-1000

Sample reading: 18 PPM

Check calibration:

Adjust the analyzer calibration potentiometer so that 50 ppm of oxygen is being added to the sample. This is the change in actual oxygen content of the sample.

Assume that the analyzer changes its output to read 52.

The change in output indications is  $52 - 18 = 34$  when 50 PPM  $O_2$  is added. Therefore, the span potentiometer should be adjusted to give a reading of

$$(18 \times \frac{50}{34}) + 50 = 76.5 \text{ PPM}$$

**NOTE: For details, see Appendix: Calibration Considerations.**

## Installation

---

### 3.1 Location

With proper shielding of the leads, the analyzer and the readout device can be separated by as much as 1,000 feet. However, they should be placed as close together as possible. For the most convenient operation, the readout recorder or meter should be within view of the controls, particularly when the unit is being calibrated. Other location considerations:

- 1) The analyzer should be sheltered from the elements.
- 2) Ambient temperature must be within **30 to 120 °F**.
- 3) The unit should not be subject to excessive shock or vibration.
- 4) It should be as close as possible to the sample point.
- 5) There must be access to the back and side of the unit for connection or maintenance of sample lines and power.

**NOTE: Since the level of the electrolyte in the measuring cell is critical and the water level control system for the humidifier is gravity sensitive, THE ANALYZER MUST BE MOUNTED SO THAT THE BOTTOM OF THE CASE IS LEVEL.**

Figure 3 depicts a typical system layout.

### 3.2 Electrical Connections

A diagram of the necessary electrical connections is shown in Figure 4.

**Note: See the Interconnection Diagram (drawing A-21916) included in the back of this manual, as well as any Addenda that may be included with this manual for information specific to your instrument.**

The connections include a terminal for grounding the analyzer case and chassis in accordance with accepted industrial practices. The maximum power requirement is less than **1½ amperes at 115 VAC**.

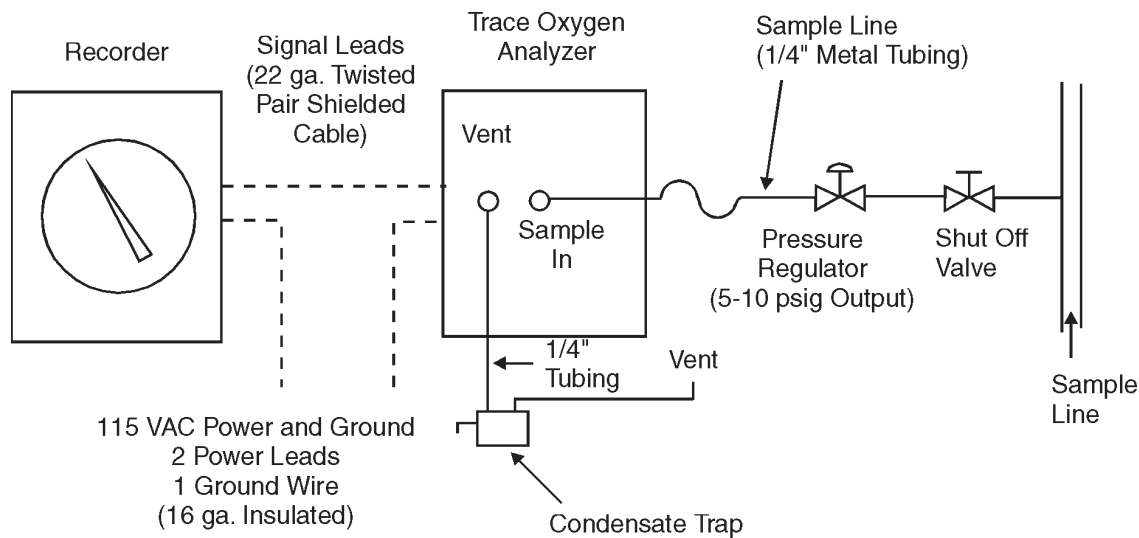

Figure 3: Typical System Layout

### 3.3 Sample Connections

The sample line is connected at the back of the analyzer case as depicted in Figure 5. Use care in assembling any part of the sampling system to avoid leaks. Oxygen can diffuse into the system through small leaks even when sample pressure is much greater than atmospheric pressure.

1. **Connectors.** Use straight tube connectors where possible. This facilitates removal of the analyzer section from the case during maintenance or service.
2. **Lines.** Lines should consist of metallic tubing, since oxygen can diffuse through plastic. Use continuous tubing where possible.
3. **Vent.** The analyzed sample is vented through the back of the unit as shown in Figure 5.

The analyzer should have a vent line of  $\frac{1}{4}$ " diameter tubing at least two feet long, running **downward** from the vent connection. This is to prevent air from diffusing into the reservoir and dissolving into the humidifier make-up water.

If it is not desirable to vent the sample into the atmosphere, a vent line to carry the sample to a suitable venting area will be required. The sample leaves the vent connection of the analyzer saturated with water vapor at a temperature somewhat above ambient, so a suitable trap to remove condensate without plugging the vent line will be required. The vent line should also be arranged so that it cannot become plugged by dirt or dust.

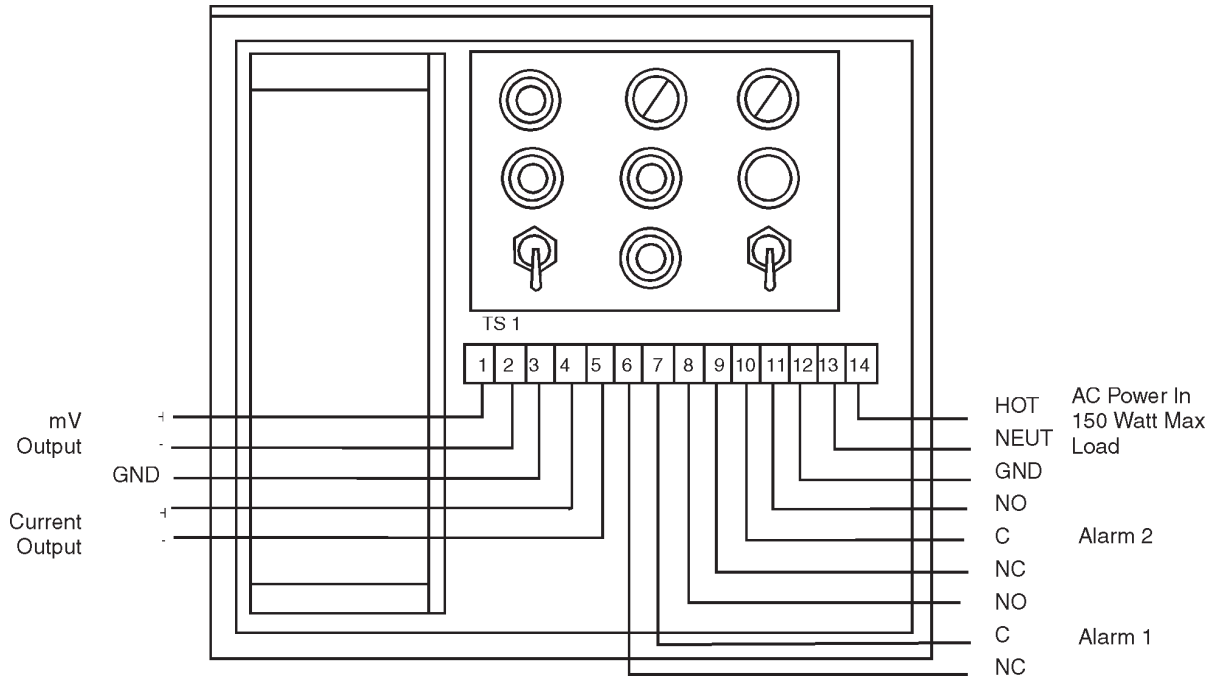

Figure 4: General Connection Diagram

See the specific Interconnection Diagram for your instrument in the drawing package located at the back of the manual. See also any Addenda that may be included with this manual.

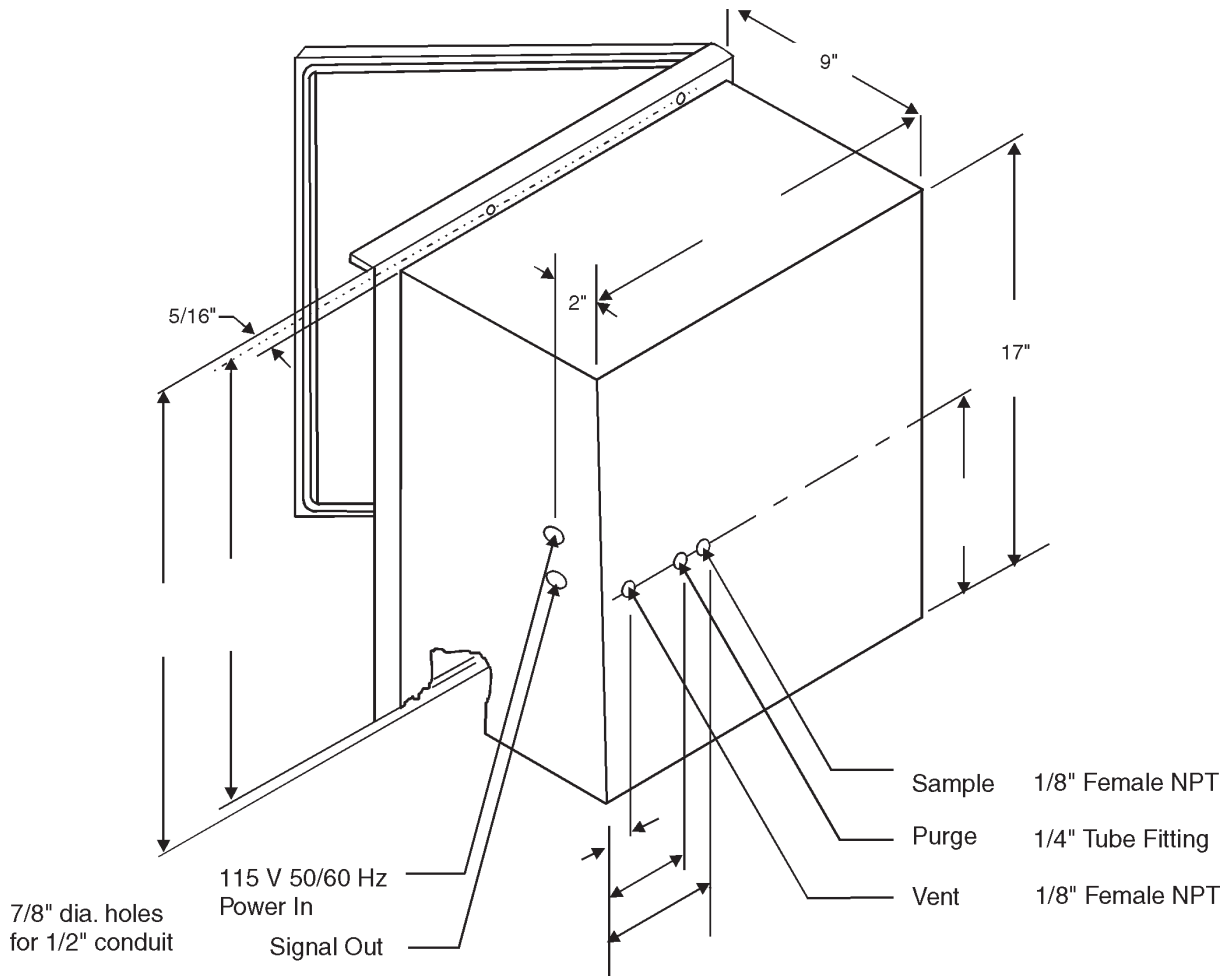

Figure 5: Gas Connections to Back of Analyzer



## Operations

---

### 4.1 Filling the Reservoir

The reservoir is located on the right side of the analyzer case.

- 1) Insure that the cap on the drain spout is securely tightened.
- 2) Remove cap from fill port on top of reservoir.
- 3) Pour distilled water into reservoir until it is half full (about one quart). The water will automatically flow into the humidifier column.
- 4) Replace cap on fill port and securely tighten. A missing or loose cap will permit the sample to vent into the analyzer case.

### 4.2 Detector Cell

The cell is located in the heated compartment on the left side of the analyzer case, as shown in Figure 6. To open the compartment, unscrew the captive knurled knobs at the top and bottom of the compartment and remove the plastic window.

#### 4.2.1 Cell Packaging

The cell is packaged separately from the analyzer. It is filled with distilled water to prevent oxidation of the electrodes from exposure to the atmosphere. The cell should be left filled with the distilled water until the analyzer is installed and ready for operation. The cell should not be exposed to the atmosphere for any prolonged duration.

#### 4.2.2 Electrolyte

The cell electrolyte is Teledyne Type A, used in applications where there is a complete absence of acidic anhydrides ( $\text{CO}_2$ ,  $\text{SO}_2$ ) in the sample gas. Type A electrolyte is a 10% solution (w/v) of reagent-grade potassium hydroxide (KOH) in distilled water.

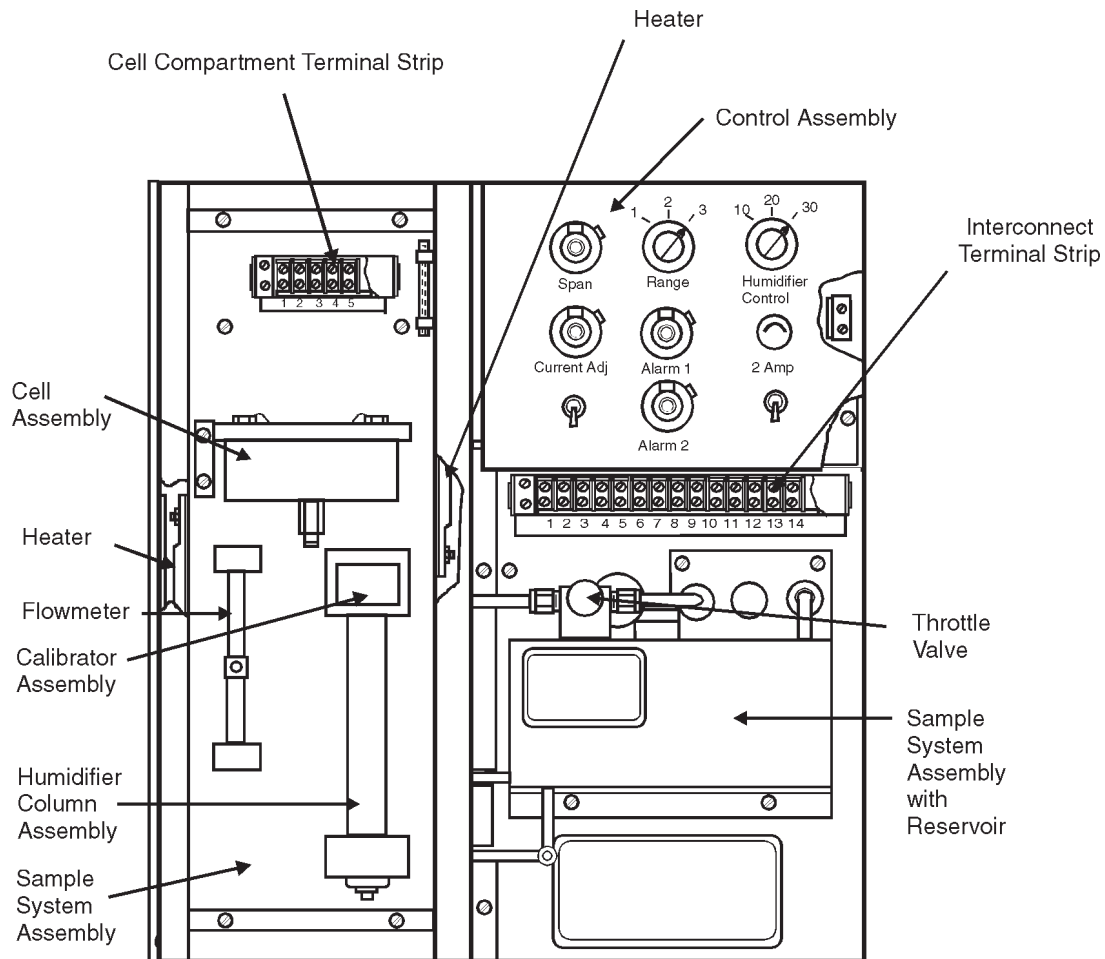

Figure 6: Typical Model 306WA With 2 Alarm Option

**WARNING:** *Type A electrolyte is caustic. Use extreme care in handling. Protective equipment including but not limited to gloves and safety glasses should be worn while handling electrolyte. Refer to the Material Safety Data Sheet in the Appendix regarding potential hazards and corrective action in case of accident.*

Type B electrolyte is a 20 % solution (w/v) of potassium carbonate and should be used when the CO<sub>2</sub> level in the background gas is between 500 ppm and 1 %. This narrow range is rarely encountered. It is, however available from the factory.

Type C electrolyte is a 20 % solution (w/v) of potassium bicarbonate and should be used when the CO<sub>2</sub> level in the background gas is between 1 and 100 %.

Sufficient electrolyte is provided for initial servicing of the cell. Electrolyte for future service should be ordered from Teledyne. When ordering, specify type and quantity.

### 4.2.3 Cell Installation

Prior to servicing and installing the cell, inspect the lead electrode in the acrylic base for signs of oxidation, indicated by a reddish-brown or yellow discoloration. If discoloration is noted, clean the cell as directed in section 5.5.2 before placing it in service.

**WARNING:** *Type A electrolyte is caustic. Use extreme care in handling. Protective equipment including but not limited to gloves and safety glasses should be worn while handling electrolyte. Refer to the Material Safety Data Sheet in the Appendix regarding potential hazards and corrective action in case of accident.*

- 1) Remove the four cell mounting bolts which secure the plastic cover. Pour out the distilled water.
- 2) Pour about half the furnished electrolyte into the cell and slosh until all components within the cell are wetted by the solution. Drain and dispose of the solution.
- 3) Wipe the top of the cell and the O-ring with a clean, disposable tissue to remove solution from the exterior. **DO NOT** touch the interior of the cell.
- 4) Carefully pour in electrolyte until it just touches the bottom edge of the silver screen assembly at all points. This is indicated by a definite wicking of electrolyte onto the screen assembly at every point along the bottom edge. It is essential at this point that the bottom edge of the screen assembly be wetted at all points (as seen by the wicking action), but not over-immersed (as large a surface area as possible of the screen assembly must remain above the electrolyte, while every point of the bottom edge must be wetted).

**NOTE:** *The electrolyte level in the cell is critically related to its sensitivity due to the change in the cathode surface area exposed to the electrolyte.*

- 5) Carefully place the cell under the cell mounting plate with the outer terminal toward the front. Secure in place with four bolts supplied with the cell. Refer to Figure 7.
- 6) Connect the red lead to the center terminal and the black lead to the outer terminal.

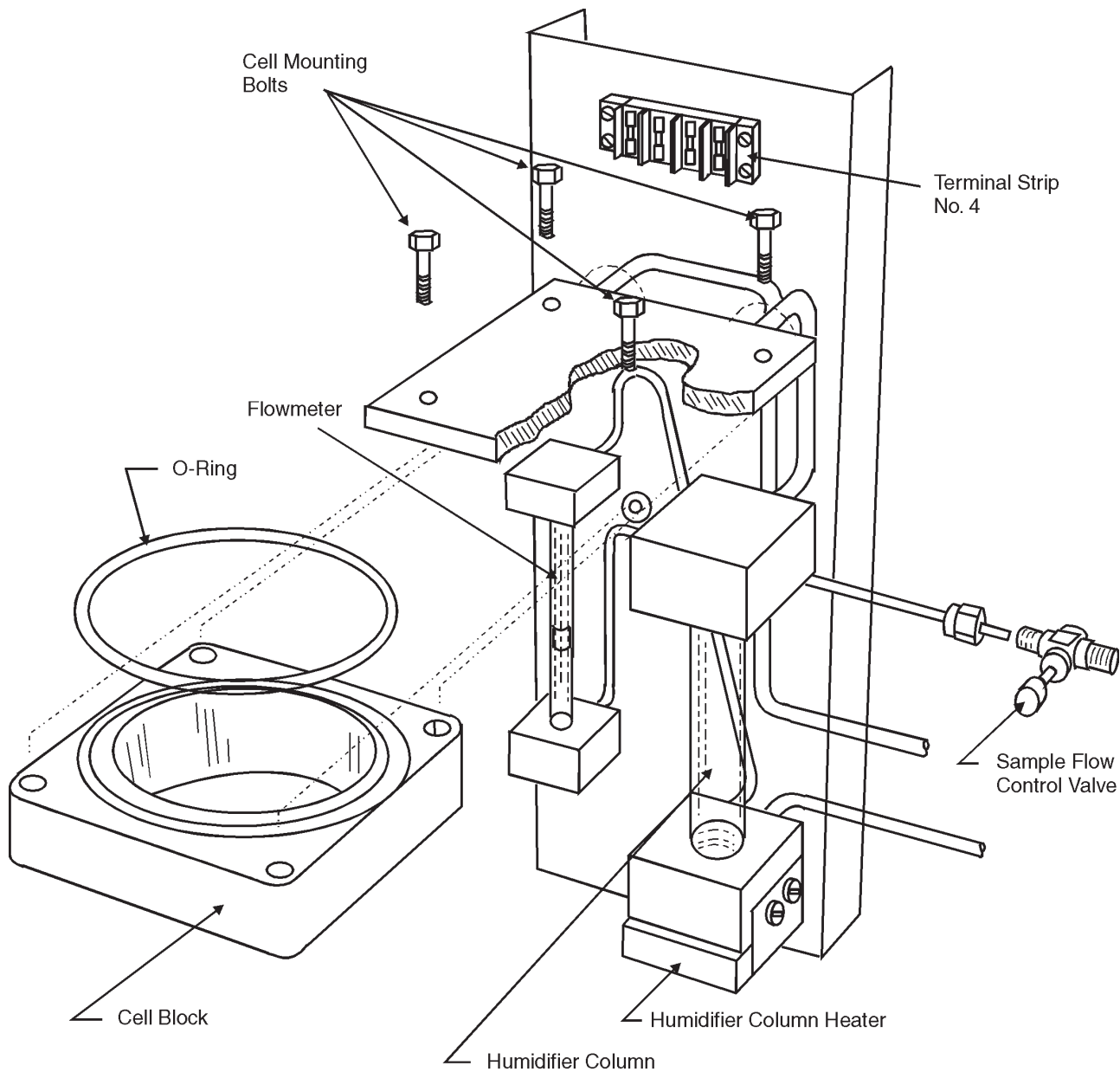

Figure 7: Cell Compartment Components

**NOTE:** *The silver screens in the cell have been specially treated to provide proper detection characteristics. They must be kept clean and MUST NOT be touched. Even clean fingers secrete natural oils which contaminate the screens. If the screens need straightening, wash a small pair of tweezers thoroughly to remove any grease, rinse them in distilled water, and use them to carefully bend the screens back into place.*

### 4.3 Calibrator

The calibrator is located at the top of the humidifier column as shown in Figure 6. Also refer to Figure 8.

- 1) Disconnect the electrical leads attached to the terminal posts.
- 2) Remove the two screws adjacent to the terminal posts. Remove the assembly, being careful to avoid touching the calibrator wick against other surfaces.
- 3) Dip the wick into fresh electrolyte solution and then shake to remove excess solution. Blot the end of the wick with an absorbent tissue.

**WARNING:** *Type A electrolyte is caustic. Use extreme care in handling. Protective equipment including but not limited to gloves and safety glasses should be worn while handling electrolyte. Refer to the Material Safety Data Sheet in the Appendix regarding potential hazards and corrective action in case of accident.*

- 4) Carefully slide the calibrator assembly back into the humidifier block cavity and secure with two mounting screws. The screws must be turned down firmly to insure a leak-free O-ring seal between the assembly and the humidifier block.
- 5) Reconnect the electrical leads to the terminal posts.

**CAUTION:** **The calibrator wick and electrodes must be kept clean and must not be touched. Contamination will result in calibration errors.**

### 4.4 Throttle Valve

The throttle valve is located at the top of the reservoir tank. Refer to Figure 6.

- 1) Gently turn the valve counterclockwise. A stream of bubbles should appear at the base of the humidifier column, and the float of the flowmeter should rise in its tube.

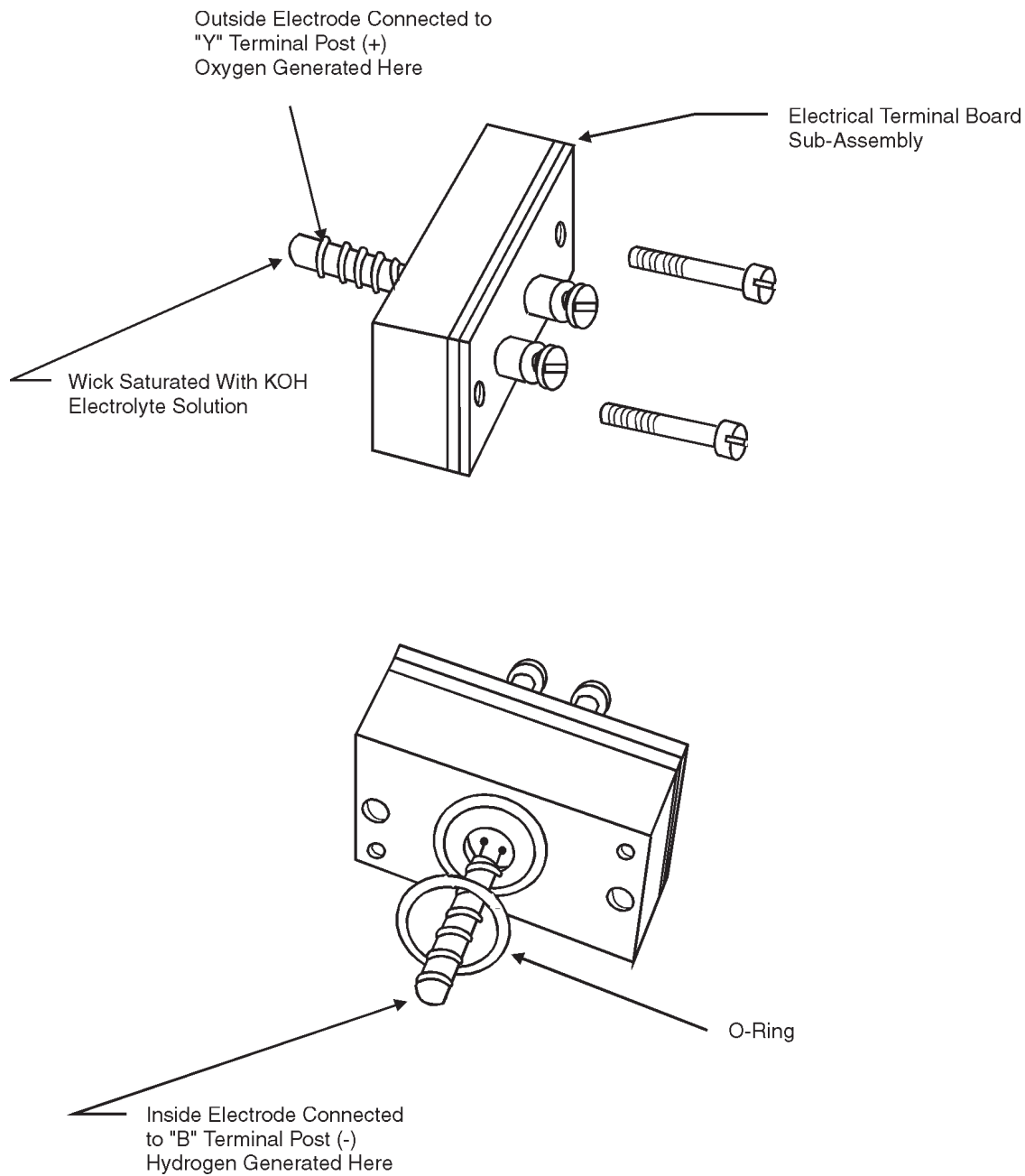

Figure 8: Calibrator Assembly

- 2) Adjust the valve so that the flowmeter float is centered in the flow rate reference indicator.

**CAUTION:** Open the throttle valve carefully. Excessive flow rate may cause water in the humidifier column to be carried into the detector cell. This can cause erratic readings and may require disassembly, cleaning, and refilling of the sensor.

- 3) The flowmeter indicator has been factory set to a flow rate of **150 cc/min.** for the specified sample gas.

**CAUTION:** Excessive flow rate may cause water in the humidifier to be carried to the flowmeter causing moisture to accumulate. This can cause the ball to stick in the flowmeter. To remove moisture, remove the flowmeter and allow to air or blow dry. Refer to the detailed instructions in Figure 10 for removal and installation of the column.

#### 4.5 Humidity Control

The humidity control is located on the front panel of the control unit, and is adjusted to maintain a constant electrolyte level in the detector cell. In effect, the control governs the humidity of the sample which is directed to the cell.

- 1) At start-up, the humidity control knob should be set to **30**. Note the cell electrolyte level as a reference. Approximately 3/32" of the bottom edge of the screen assembly should be immersed in the electrolyte.
- 2) Operate the analyzer for 24 hours and compare the electrolyte level with the "reference" established in Step 1. If the level is lower than the reference, adjust the knob a few divisions clockwise; if higher, adjust a few divisions counterclockwise.
- 3) Operate another 24 hours and repeat Step 2.
- 4) Continue adjustments at ever-increasing intervals until a constant electrolyte level is attained in the cell.

Once the analyzer is suitably located, all components serviced and installed, and sample and electrical connections made, the instrument is ready for operation.

## 4.6 Power

When power is turned on, it is used to heat the cell compartment and to provide current to the calibrator. The cell operates without applied power, but its output will vary with changes in ambient temperature.

## 4.7 Warm-Up and Stabilization

When the analyzer is initially put into operation, the air in the lines and sample passages will drive the output indication to the top of the scale. The time required to sweep out this residual air may be several hours before an on-scale indication is reached. During this time the cell compartment is heating and reaching its controlled temperature.

### 4.7.1 Calibration

The analyzer is calibrated by adding a known amount of oxygen into the sample stream. The sensitivity of the analyzer is adjusted until the change indicated by the analyzer is equal to the amount of oxygen actually added.

1. Adjust the sample flow rate until the flowmeter float is centered in the flowmeter reference indicator. Note the reading of the external recorder or meter.
2. Turn the calibrator power switch to ON. Adjust the calibrator current dial to read the amount of oxygen to be added. The dial reads 0 to 100 PPM O<sub>2</sub> (See Appendix A4 for the O<sub>2</sub> settings).
3. Leave the power and current controls in the positions selected above. The calibrator current will continue to flow until the calibrator power switch is turned OFF.
4. If the external recorder/meter does not indicate the proper amount of oxygen (sample reading plus added oxygen), adjust the sensitivity control until it does.
5. When the output reaches the proper equilibrium, turn the calibrator power switch to OFF. The recorder/meter will move downscale to indicate the oxygen content of the sample.

If the output indication requires adjustment of more than 10%, the indicated oxygen content of the sample will differ noticeably from the original indication. Repeat steps 2, 3, and 4, using the new sample oxygen content value as a starting point.

The above procedure should achieve the correct sensitivity setting though a series of successive approximations.



## **Maintenance & Troubleshooting**

---

After the analyzer has been put into operation and calibration has been accomplished, routine inspection will be required for normal operation.

### **5.1 Flowmeter and Humidifier**

The flowmeter and humidifier column must be checked daily to insure proper flow, and corrected as necessary. Refer to sections **2.2: Humidifier** and **4.4: Throttle Valve**.

### **5.2 Cell Electrolyte Level**

The level of electrolyte in the cell must be checked daily and adjusted as necessary. Refer to section **4.2.3: Cell Installation**.

### **5.3 Reservoir**

The water level in the reservoir should be checked at least every two weeks. Follow this procedure:

- a) Remove the cap from the filler spout.
- b) Obtain a clean glass tube about 4 to 5 inches long and about ¼ " outer diameter.
- c) Lower the tube into the tank through the filler spout until it touches bottom.
- d) Place a finger over the end of the tube, and withdraw the tube from the tank. The height of water in the tube is the height of the water level in the tank.
- e) If the water level in the reservoir is below **1 "**, add a quart of distilled water.
- f) Replace the filler spout cap securely after verifying that the O-ring seal is in good condition.

## 5.4 Calibration

### 5.4.1 Internal Calibration

The sensitivity of the unit should be checked at two to four week intervals. Calibration procedures are described in section 2.4, 4.7.1 and appendix A4.

### 5.4.2 Span Gas Calibration

The 306 is designed for accuracy measurement. It has an internal calibrator. The calibration process is stated in the section that follows, in section 4.7.1 and in appendix A4.

- Span gas is not required.
- Span gas is an option to calibrate 306 analyzer.
- Span gas should be between 70-90% of the primary (working) range.

**NOTE:** *Refer to Section 4.3 for calibrator preparation prior calibration.*

There are two connection methods that can be utilized for the sample and span inputs:

#### 1. Three Way Valve Method

- Install a three-way valve as follows:
  - Connect a common port to the inlet of the analyzer.
  - Connect span gas bottle to the normally closed port.
  - Connect sample to the normally open port.
- Turn on the sample gas.
- Adjust the flow control inside the analyzer until the flow ball is inside the target (on the flow tube).
- Purge the analyzer for 12 to 16 hours when the instrument is being installed for the first time or when replacing the cell.
- Slowly switch the 3-way valve to the span gas.
- Slowly adjust the span gas regulator until span gas flow is about the same as the sample flow.
- Wait until the reading is stabilized. Adjust span pot so that the analyzer is reading the same O<sub>2</sub> concentration as indication on the span gas bottle.
- Now the analyzer is calibrated.
- Switch the 3-way valve to sample and the instrument is ready to go online.

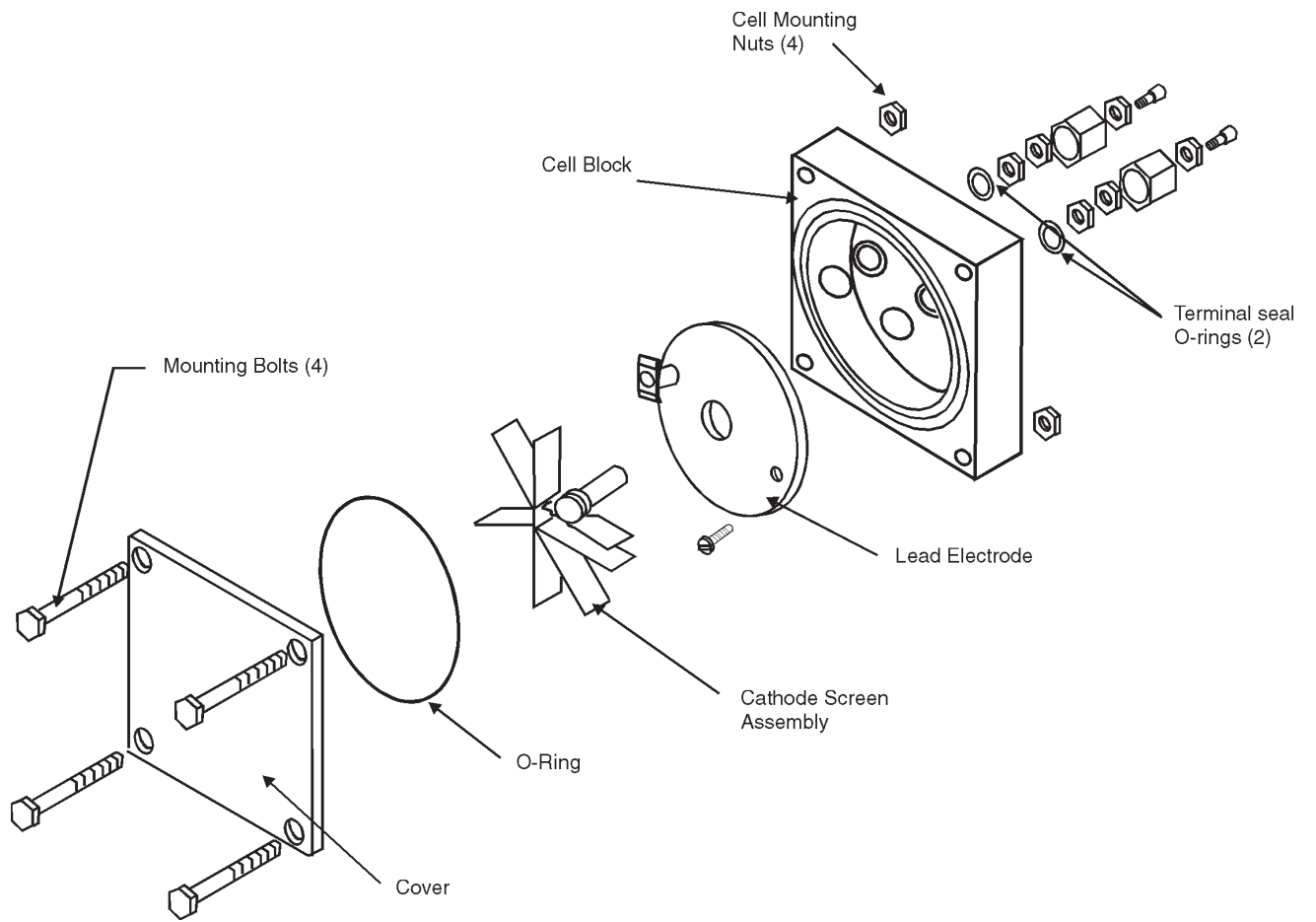

Figure 9: Cell Assembly

## 2. Quick Disconnect Fitting Method

**NOTE: Only stainless steel tubing must be connected to the quick disconnect fitting.**

The steps are as follows:

- Connect 1/4" tubing with the male quick disconnect fitting to the Model 306 sample inlet.
- Turn on the sample gas.
- Adjust the flow control inside the analyzer until the ball is inside the target (on the flow tube).
- Purge the analyzer for 12 to 16 hours when the instrument is being installed for the first time or when replacing the cell.
- Remove the quick disconnect from sample inlet and connect it to the span inlet.
- Slowly adjust the span gas regulator until span gas flow is about the same as the sample flow.
- Wait until the reading is stabilized. Adjust span pot so that the analyzer is reading the same O<sub>2</sub> concentration as indicated on the span gas bottle.
- Now the analyzer is calibrated.
- Remove the quick disconnect from span inlet and connect it to the sample inlet and the instrument is ready to go online.

## 5.5 Cell

The electrochemical reaction in the analytical process results in the accumulation of lead ions in the electrolyte, making the replacement of the lead electrode or the electrolyte necessary.

### 5.5.1 Electrolyte Replacement

Teledyne recommends that the electrolyte be replaced when foreign material is accumulated in the cell or when the cell sensitivity is noticeable decreased. This is typically identified when a large change is made to the span pot setting during calibration. Remove the cell from its compartment, and drain, clean, rinse, and refill as described in section **4.2.3**. After the cell is serviced or replaced, calibrate the analyzer as outlined in Section **4.7.1: Calibration Using the Internal Calibrator**.

### 5.5.2 Lead Electrode

If electrode is discolored when new, or has obviously deteriorated from use, it may be necessary to clean or replace the electrode. Use the following procedure while referring to Figure 9.

If the lead electrode is simply discolored, clean the entire cell according to the following procedure:

- a) Heat a quart of Teledyne cleaning solution to slightly below the boiling point, and completely fill the cell cavity with the heated solution.
- b) Let the solution stand for approximately five minutes. Drain and dispose of solution.
- c) Repeat steps a) and b).
- d) Rinse the cell with distilled water and then fill with electrolyte. Let stand for approximately two minutes and then drain and dispose of electrolyte.
- e) Refill the cell with electrolyte, immersing the lower edge of the silver screens to about a **3/32 "** depth.

If the lead electrode is obviously beyond repair, it must be replaced.

- a) Remove the terminal nuts by removing them from the mounting screws.
- b) Carefully remove the screw which holds the screen assembly in place. Remove the screen assembly. Use clean tweezers and **do not touch it with your fingers**. Avoid any possible contamination of the screen.
- c) Cleanse the cell thoroughly in electrolyte solution.
- d) Insert the new lead electrode in place in the cell body and secure with lock washers and screws.
- e) Carefully install screen assembly and secure with mounting screw.
- f) Immerse the cell assembly in hot cleaning solution and then rinse in distilled water.
- g) Install prepared cell assembly as described in section **4.2.3: Cell Installation**.

### 5.6 Screen Assembly

The screen assembly will become discolored after prolonged use due to contamination. When this occurs, and if the cell no longer displays

adequate sensitivity, the entire cell assembly must be replaced. Refer to section **4.2.3** for cell installation.

### **5.7 Calibrator**

The calibrator must be clean in order to operate properly. It should be removed and inspected each time the cell is serviced. If, on inspection, dark deposits are seen on the calibrator wick, the calibrator should be replaced. See section **4.3: Calibrator**.

The scrubber is not repairable. Once it has been determined that it is not functioning correctly, it should be replaced. To determine if the scrubber is active or not:

1. Allow sample gas with a few PPM of O<sub>2</sub> into the sensor. Record the output registered on the meter
2. Turn the scrubber on and allow zero gas into the sensor. Record the output.
3. If the output in 1 and 2 are the same, the scrubber needs to be replaced.

### **5.8 Reservoir and Humidifier Column**

Approximately once each year the reservoir and humidifier column should be drained and cleaned. Use the following procedure:

- a) Reduce sample flow to approximately **50 cc/min**.
- b) Refer to Figure 6. Place a small funnel with attached tubing beneath the drain spout which is located on the underside of the reservoir. Remove the drain spout cap and allow the reservoir and humidifier column to drain thoroughly.
- c) Replace the drain spout cap, turn the sample flow off, and remove the fill cap on the top of the reservoir.
- d) Add a small amount of electrolyte to a pint of warm distilled water. Pour the solution into the reservoir and replace the fill cap.
- e) Gently open the throttle valve and permit the sample to flow for five to ten minutes.
- f) Reduce the sample flow to **50 cc/min** and drain the solution from the reservoir. When drained, replace the drain cap and turn off the sample flow.
- g) Rinse by filling with distilled water and draining several times.

- h) If the humidifier column still retains deposits on its walls, it should be removed and cleaned with a brush and suitable cleaner. See Figure 10. After cleaning, thoroughly rinse the column in distilled water before reinstalling.

*NOTE: If electrolyte has severely etched the column, it should be replaced.*

- i) After the reservoir and column have been cleaned, refill the reservoir as outlined in section **4.1: Filling the Reservoir**.

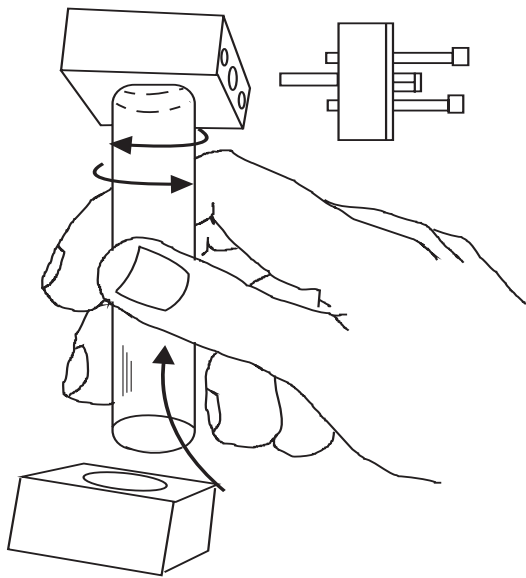

#### **Removing the Humidifier Column:**

- 1) Remove the calibrator assembly from the top humidifier block.
- 2) Grasp the tube, and with a twisting motion, work it up into the top humidifier block until it clears the bottom block completely.
- 3) Angle the bottom of the tube towards you and twist it free of the top block.
- 4) The top and bottom O-rings will remain captive in their blocks.

#### **To Reinstall:**

- 1) Engage the top of the tube in the top block at an angle and twist up into the calibrator cavity of the top block until the bottom of the tube clears the bottom block.
- 2) Swing the tube into line, and twist down into the bottom block until the tube seats.
- 3) Reinstall the calibrator assembly as described in section 4.3.

**NOTE:** *The flowmeter is similarly constructed and can be removed and reinstalled following the same procedure outlined above.*

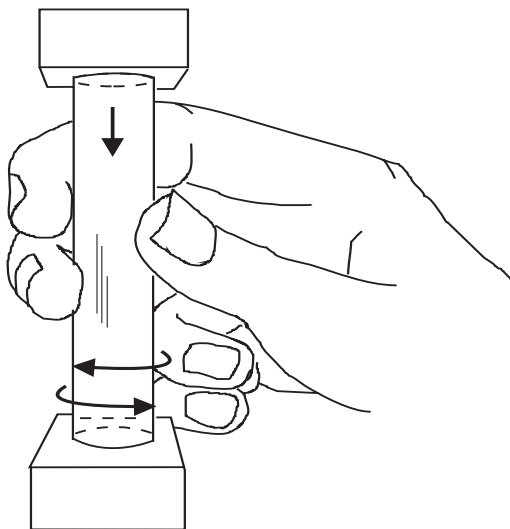

Refer to the Spare Parts List in the Appendix for replacement part numbers for the flowmeter column or humidifier column.

### 5.9 Leak Detection

The most frequent cause of trouble in trace measurement is leakage. Tiny leaks which may be unnoticeable can cause serious errors in trace measurements. One of the principal problems is that air can diffuse into a gas line through a small leak, even though the gas pressure in the line may greatly exceed atmospheric pressure.

When a leak occurs in a system where the mass flow velocity is less than the molecular velocity, gas molecules move in both directions through the leak. The net flow of a particular gas, e.g. oxygen, will depend on the relative partial pressure of that gas on each side of the leak. In a sample having only a few parts-per-million oxygen, there will be a net flow of oxygen inward unless the sample pressure is many thousands of pounds.

#### 5.9.1 Leak Detection Procedure

The procedure outlined here is based on the premise that the leak rate is independent of sample flow rate.

- a) Stop the sample flow to permit oxygen to accumulate at the point of the leak.
- b) After approximately one minute, restart the sample flow. It is advisable to practice establishing the flow rate to **150 cc/min.**, the reference flow indication on the flowmeter, with one quick turn of the throttle valve.
- c) Simultaneous to restarting the flow, start a stopwatch to measure the time required for the recorder/meter to respond to the accumulated oxygen.
- d) The following are approximate times for the accumulated oxygen to reach the cell from various points in the sample path through the analyzer at **150 cc/min.**

1.5 to 2 seconds	Calibrator
3.5 to 3.75 seconds	Base of humidifier column*
5.5 seconds	Flowmeter
6.5 seconds	Metering valve
7.5 seconds	Gas connection at rear of analyzer
> than 7.5 seconds	Sample connection lines leading to analyzer

- \* A leak at this location may indicate a leak in the column or in the reservoir system.



### 5.9.2 Cell Leak

If there is no rise in oxygen reading when the sample flow is restarted in step 5.9.1.b, the measuring cell should be checked for leaks. The two most likely leaks locations are at the two terminal seal O-rings, or at the large O-ring in the cell block mounting base.

Check that the terminals are screwed tightly into place. Frequently, when a leak occurs at a terminal connection, a greenish crystalline deposit will be found inside the cell around the terminal mounting screw. This is lead carbonate, which is formed by carbon dioxide in the air reacting with lead ions in the electrolyte.

If the large O-ring at the mounting plate is leaking, the oxygen indication will begin rising almost immediately after the sample flow is stopped. It will continue to rise until sample flow is restarted, at which time it will begin to gradually decrease.

Symptom	Cause	What To Do
No analyzer response to oxygen.	a) Poor electrical connection, or F1 fuse (a standard 2 amp Slo-Blo fuse) has blown.	a) Verify proper connection from the cell through the control unit to the external recorder or meter; check for blown fuse. Replace as necessary.
	b) Cell electrolyte level too low.	b) Inspect electrolyte level and add as necessary. See section 4.2.3, item 4.
	c) Dirty cell.	c) Remove cell and clean thoroughly. See section 4.2.3.
	d) Short between cell cathode and anode (the screen to lead—the base material—is shorted.)	d) Correct short. Refill with fresh electrolyte as needed.
	e) If d) above corrects the problem, the cell has probably been poisoned, probably by fluid flowing into the cell humidifier column.	e) Check for excessive flow-rate. Check for excessive foaming in the humidifier column. Drain and clean reservoir as necessary. Refer to section 5.8.
	f) Cell has been poisoned by a component in the sample.	f) If there has been no change in the normal sample composition, a scrubber may be required to remove the offending component.
Cell lacks sensitivity.	a) Cell electrolyte level too low, due to misadjusted or faulty humidity control.	a) Add electrolyte as necessary. Adjust humidity control. See section 4.5.
	b) Cell electrolyte too high, due to misadjusted or faulty humidity control.	b) Drain electrolyte and refill. Adjust humidity control. See section 4.5.
	c) Faulty humidity control.	c) <ul style="list-style-type: none"> <li>• Shut off main power.</li> <li>• Disconnect orange wire from TS5 terminal 5, place a voltmeter (set to AC current, range 0–100 mA) in series with TS5-5 and the disconnected orange wire.</li> </ul>

*CAUTION: High voltage AC present.*

Symptom	Cause	What To Do
Cell lacks sensitivity (continued.)	Faulty humidity control (continued.)	<ul style="list-style-type: none"> <li>• Turn humidifier control completely counter-clockwise.</li> <li>• Turn on main power.</li> <li>• While watching the voltmeter, turn the humidifier control clockwise; the meter reading should go from 0–50 milliamps. If not, replace the humidifier heater element or the humidifier heater control. To determine which should be replaced, see paragraph below.</li> </ul> <p>If there is no current, either the humidifier element or control is defective. To determine which it is:</p> <ul style="list-style-type: none"> <li>• Turn the humidifier control knob fully ccw.</li> <li>• Disconnect the voltmeter from TS5-5 and orange wire.</li> <li>• Change the voltmeter function to 200V AC.</li> <li>• Place the voltmeter across TS5-5 and TS5-4.</li> <li>• Watching the meter, turn the humidifier control knob cw and watch the voltmeter read from 0 to 120V AC (0-220V for 220VAC Application).</li> <li>• If not, replace R2 (behind the control knob); see paragraph below.</li> <li>• If there is voltage, replace the heater element; see paragraph below.</li> </ul>

Symptom	Cause	What To Do
Cell lacks sensitivity (continued.)	Faulty humidity control (continued.)	<p><b>To replace humidifier control:</b></p> <ul style="list-style-type: none"> <li>• Shut off all power and remove the AC power cord from the power source.</li> <li>• Refer to upper right-hand corner of the control unit. Remove the wiring and controls. Replace R2 with appropriate part, P/N P31 (115VAC), P/N R1212 (220VAC).</li> </ul> <p><b>To replace humidifier heater element:</b></p> <ul style="list-style-type: none"> <li>• Shut off all power and remove the AC power cord from the power source.</li> <li>• Refer to left-hand side, bottom of the cell compartment.</li> <li>• Using Allen wrench size 5/64 to remove Allen screw from the bottom of the humidifier column; pull out the heater element, and unsolder the wires.</li> <li>• Replace with new heater element (P/N R991 for 115VAC or P/N R1211 for 220VAC) Solder wires, and replace heater element.</li> </ul>
	d) Cell compartment not at proper temperature (104 °F).	d) Verify that the power switch is ON. Check condition of 2A fuse.
	e) Faulty triac temperature control circuit.	e) • Turn off the power. Remove the power from the power source, unplug the temperature control board. Remove the cell compartment cover. Refer to Interconnection diagram. • Connect voltmeter (set to range 20k ohm) to terminals 1 and 2 of terminal strip TS4.

Symptom	Cause	What To Do
Cell lacks sensitivity (continued.)	Faulty triac temperature control (continued.)	<ul style="list-style-type: none"> <li>• The DMM should read 230 to 250 ohms (115VAC) 500 to 700 ohms (220VAC). Move DMM to TS4 # 4&amp;5. The DMM should read between 7,000 to 10,000 ohms. If above test is OK, replace the temperature control P.C. Board</li> <li>• If none of the above improve the sensitivity, replace the cell.</li> </ul>
Calibrator slow to respond to added oxygen.	a) Calibrator wick needs wetting.	a) Disassemble calibrator and moisten the wick. See section 4.3: Calibrator.
Calibrator shows no indication.	a) Lack of power, poor connection, or dry wick.	a) Verify that the main power and calibrated power switches are ON. b) Check connectors to calibrator. c) Check for dry wick. <ul style="list-style-type: none"> <li>• Measure the voltage between terminals 6 and 7 on terminal strip TS5.</li> <li>• With calibrator energized, the voltage drop across the calibrator electrodes is 1 to 3 V. However, a dry wick will cause voltages as high as 25 volts.</li> </ul> d) Disassemble calibrator and moisten the wick. See section 4.3.

---

<b>Symptom</b>	<b>Cause</b>	<b>What To Do</b>
Calibrator current is erratic.	a) Poor electrical connections.	a) Check for proper connections between the control unit and calibrator on terminal strip TS5. b) Ensure that brown (13) and yellow (14) wires connect to brown and yellow posts respectively on calibrator assembly in the cell compartment. c) Moisten wick. See section 4.3.
Proper calibration current exists, but there is no cell response.	a) Short circuit in calibrator.	a) Verify cell response to oxygen by loosening the calibrator assembly to introduce air, and then bolt back in place. Recorder/meter should show increase. b) If there is no response, inspect the calibrator for obvious shorts. If not easily repairable, replace the calibrator.

---

---

## Appendix

---

### Specifications

<b>Ranges:</b>	0-1, 0-10, 0-100 ppm (optional high range to 1000 ppm, optional low range to 500 ppb).
<b>Sensitivity:</b>	0.5% of Full Scale.
<b>Accuracy:</b>	$\pm 2\%$ of Full Scale at constant temperature and pressure (temperature and pressure of calibration {for ranges 10 ppm and above}). For ranges 1 ppm and below, Instrument Accuracy must take into account Sensor Offset Error which has been experimentally determined to be 30 ppb. $\pm 5\%$ of Full Scale over operating temperature (once temperature equilibrium has been achieved)
<b>Response Time:</b>	90% in less than 1 minute (for changes in the lowest range).
<b>System Operating Temperature:</b>	5 °C to 50 °C.
<b>Sensor Type:</b>	Electrochemical "Flower Cell".
<b>Signal Output:</b>	0-1V DC (4-20mA DC optional)
<b>Sample Requirement:</b>	Flow: 150 cc/min (Specified flow rate is required only during calibration). Pressure: 1 to 150 psig. Temperature: 15 °C to 38 °C
<b>Power Requirement:</b>	115 VAC, 50/60 Hz (220 optional)
<b>Alarm Output:</b>	2 alarms optional.
<b>Calibrator:</b>	Electrolytic Faradic Calibrator.

### Spare Parts List

QTY.	PART NO.	DESCRIPTION
1	C1372	Cell assembly
<b>NOTE: Specify cell class and range of analyzer when ordering.</b>		
2	O5	O-ring, cell terminal
1	O25	O-ring, cell seal
2	O26	O-ring, calibrator
2	O9	O-ring, humidifier column
2	O8	O-ring, reservoir cap
2	O204	O-ring, flowmeter
1	A4616	Calibrator assembly
1	A33748	Thermistor assembly
1	A3042	Humidifier column assembly
1	R2454	Humidifier column heater (110V)
1*	R2453	Humidifier column heater (220V)
1	A5267	Reservoir cap
5	F10	Fuse, 3AG-2A
5	F6	Fuse, 3AG-1/4A, Slo-Blo
2	H2	Heater (306WA)
2	H68	Heater (307WA, 308WA)
1	B6274	Flowmeter ass'y (specify background gas)
1	C14449	PC Board, Proportional temp. control (For applications less than 10 PPM)
1*	C41274	PC Board, Proportional temp. control (220V)
1*	B29600	PC Board, E/I converter, isolated (O option)
1*	B14702	PC Board, E/I converter, neg. gnd. (I option)
1*	A9309	PC Board, Alarm comparator, dual (-2 opt.)
1	A44608	Type A Electrolyte
1	A44609	Type C Electrolyte
1	A50510	Cal Kit (Eelectrolyte for calibrator)
1	P31	Rheostat (Humidity Control Resistor) -1.5k, 115V
1	R1212	Rheostat (Humidity Control Resistor) -5.0k, 220V

\* optional

A minimum charge is applicable to spare parts orders.

**IMPORTANT: Orders for replacement parts should include the model number, serial number, and range of the analyzer for which the parts are intended.**



SEND ORDER TO: **TELEDYNE ANALYTICAL INSTRUMENTS**  
16830 CHESTNUT STREET  
CITY OF INDUSTRY, CALIF. 91749

TELEPHONE: (888) 789-8168  
(626) 934-1500  
(626) 961-9221

FAX: (626) 961-2538  
(626) 934-1651

TECHNICAL SUPPORT: (626) 934-1673

WEB: [www.teledyne-ai.com](http://www.teledyne-ai.com)

or your local representative

## Drawing List

### **306WA**

A-5855 Outline diagram  
A-21916 Interconnection diagram  
A-8704 Piping schematic  
D-41307 Schematic diagram  
D-43645 Wiring diagram

### **307WA**

B-19026 Outline diagram  
B-20282 Interconnection diagram  
A-8704 Piping schematic  
D-19722 Schematic diagram  
D-29555 Wiring diagram

### **308WA**

B-3370 Outline diagram  
B-6437 Interconnection diagram  
A-8704 Piping schematic  
B-6428 Schematic diagram  
A-6423 Wiring diagram

## Calibration Data

### Range

The ranges of this analyzer are:

Range Switch Position No. 1 \_\_\_\_\_ PPM O<sub>2</sub>  
 Range Switch Position No. 2 \_\_\_\_\_ PPM O<sub>2</sub>  
 Range Switch Position No. 3 \_\_\_\_\_ PPM O<sub>2</sub>

### Output Signal

The output signal is \_\_\_\_\_ D.C.

### Background Gas

This analyzer is intended to measure oxygen in a background of:

\_\_\_\_\_

The flowmeter has been set to indicate a flow of 150 cc/min. of this gas. If any other type of gas is to be analyzed, the flowmeter must be reset for that gas, using a displacement type flowmeter, when the flow is set to 150 cc/min.

### Calibration Table

Your calibrator will generate 0-100 ppm of oxygen.

To set calibrator: Turn calibrator switch to ON position; turn calibrator dial to read amount of oxygen to be added.

	<u>Calibration Current (mA)</u>
To add: 10 ppm set calibrator dial to read 100	.4
20 ppm set calibrator dial to read 200	.8
30 ppm set calibrator dial to read 300	1.2
40 ppm set calibrator dial to read 400	1.6
50 ppm set calibrator dial to read 500	2.0
60 ppm set calibrator dial to read 600	2.4
70 ppm set calibrator dial to read 700	2.8
80 ppm set calibrator dial to read 800	3.2
90 ppm set calibrator dial to read 900	3.6
100 ppm set calibrator dial to read 1000	4.0

**Cell Class:** \_\_\_\_\_

**Electrolyte Type** \_\_\_\_\_

- Type A: 10% potassium hydroxide in distilled water
- Type B: 10% potassium carbonate in distilled water
- Type C: 20% potassium bicarbonate in distilled water

---

## Calibration Considerations

In order to calibrate the Model 366, all that is required is to center the float of the flow tube in the target, add a known quantity of oxygen (0–100 PPM) to the sample gas and adjust the span according to the example on page 2.4. It should not be necessary to compensate for changes in altitude or ambient temperature.

The flow tube is a mass flow device and therefore automatically compensates for altitude changes should the instrument be moved to a higher elevation (in this instance a higher span setting will be required since the sensing element is sensitive to the partial pressure of oxygen).

The ambient temperature does not affect the flow rate through the analyzer since the flow tube is located in the same temperature controlled compartment as the cell assembly.

Furthermore, it should be noted that the only time the flow rate is critical is when calibration is being accomplished using the internal calibrator. When span gases are used and when sample gas is being analyzed the flow can vary  $\pm 10\text{--}20\%$  and more without changing the reading. It is best, however, to keep the sample flow so that the float in the flow tube is at or near the center of the target. Otherwise, a different humidifier setting may be required.

If positioning the float in the center of the target is in error by plus or minus one-quarter of the float's diameter, an error of approximately  $\pm 1.5\%$  of reading\* will be produced.

There are instances when it will be necessary to reset or check the exit flow of sample gas and set or reset the position of the target on the flow tube:

- When a different background gas is being analyzed.
- When the target has been accidentally repositioned on the flow tube.

The vent flow should be measured either with a volume displacement flow device (e.g. a “bubble-o-meter”) or a calibrated rotometer with correction factors for ambient temperature and pressure, and sample gas density and viscosity. When using a volume displacement flow device it will be necessary to correct the 150 cc/min flow rate for ambient temperature and pressure. It will also be necessary, using either type of flow measuring device, to compensate for the increase in flowrate due to humidifying the sample gas. (The flow tube inside the analyzer is measuring the **dry** gas flowrate.)

---

\* If the actual oxygen concentration were, for example, 8.0 ppm, the resultant reading would be 7.9 (float high) or 8.1 (float low).

To determine the corrected vent flow rate it will be necessary to know the ambient temperature (in °K), the ambient pressure (in mm Hg) and the vapor pressure of water at ambient temperature.

Ambient temperature can be measured in °Centigrade or °F and converted to °K.

$$\text{Degrees C} = \frac{5}{9} (\text{°F} - 32)$$

$$\text{Degrees K} = \text{°C} + 273$$

Ambient pressure can be measured with an accurate barometer.

$$P(\text{mm Hg}) = \frac{P(\text{in Hg}) \times 760}{30.00}$$

or by knowing the altitude

$$P(\text{mm-Hg}) = 760 - (2.50 \text{ per } 100 \text{ ft. of altitude})^*$$

The vapor pressure of water at ambient temperature can be obtained from Table 1 on page A.8.

To determine the corrected flow ( $F_{\text{corrected}}$ ), substitute the ambient temperature, pressure and vapor pressure of water in the following formula:

$$F_{\text{corrected}} = 150 \text{ cc/min} \times \frac{T}{294 \text{ °K}^{**}} \times \frac{760 \text{ mm-Hg}}{P} \times \frac{(P + P_{\text{water}})}{P}$$

Where:

- T = ambient temperature (in °K)
- P = ambient pressure (in mm Hg)
- $P_{\text{water}}$  = vapor pressure of water at ambient temp. (in mm Hg)

By way of example, suppose that the target's position on the flow tube is in question and it has been determined that the ambient temperature is 77 °F and the altitude where the instrument is being used is 5000 ft. above sea level.

$$\text{Ambient Temp: } \text{°K} = \frac{5(77-32)}{9} + 273 = 298 \text{ °K}$$

\* This approximation is within ±0.5% of the ICAO Standard Atmosphere over the range 0-7500 ft. above sea level. Ref: "Fluid Mechanics for Engineering Technology" by Irving Granet, Prentice Hall, pp 83-84.

\*\* Reference ambient temperature : 294 °K (21 °C) was the ambient temperature used in the Faradaic calculations.

Ambient Pressure:  $P(\text{mm-Hg}) = 760 - (2.50 \times 50) = 635 \text{ mm Hg}$

Vapor Pressure of Water (at 298 °K): 23.9 mm Hg

Corrected Flow:  $F_{\text{corr}} = 150 \times \frac{298}{294} \times \frac{760}{635} \times \frac{(635+23.9)}{635} = 189 \text{ cc/min}$

From the above computations, the exit flow rate should be set to 189 cc/min. using an appropriate flow measuring device and the target repositioned if necessary so that the float is centered within the target opening.

Subsequently, it should not be necessary to measure the exit flow unless another circumstance, of the type listed above, occurs.

**Table 1: Vapor Pressure of Water  
(From 288–308°K)**

---

Ambient Temperature (°K)	Vapor Pressure of Water (mm Hg)
288	12.9
289	13.7
290	14.6
291	15.6
292	16.6
293	17.7
294	18.8
295	20.0
296	21.2
297	23.9
298	23.9
299	25.4
300	26.9
301	28.6
302	30.7
303	32.1
304	34.0
305	35.9
306	38.0
307	40.2
308	42.5

**NOTE: The MSDS on this material is available upon request through the Teledyne Environmental, Health and Safety Coordinator. Contact at (626) 934-1592**