

4000 Series

Gas Chromatograph



Air Separation

A robust and reliable solution for impurity detection in high-purity gases is a requirement for the air separation industry whether for process control or quality assurance.

Medical Grade Permanent Gases in Air Separation Unit (ASU)

Whether for cryogenic air separation or pressure swing absorption (PSA), the 4000 series can quickly separate nitrogen from composite oxygen / argon as well as detect other impurities at trace or percent levels to pharmacopoeia requirements. Additionally, a rigorous hydrocarbon separation can be done quickly to report methane / non-methane or a more comprehensive analysis separating C2s, C3s, etc.



Carbon Dioxide (CO₂)

Beverage-grade CO₂ commonly sourced from ammonia, ethanol, barley and other fermentation sources drives a necessity to certify every load for parts-per-billion (ppb) levels of benzene, acetaldehyde and methanol. The 4000 Series Model GS-T with pre-concentrating trap and flame ionization detector achieves sub-ppb detection levels of benzene / BTEX and ppb levels of lighter hydrocarbons. The very low hydrogen flow rate for both carrier and detector fuel gas minimize utility requirements.



Hydrogen (H₂)

Sales-grade hydrogen carries both process control and quality analysis requirements. Teledyne's dielectric barrier discharge (DBD) detector employed in helium ionization mode allows for fast and low detection of all components.

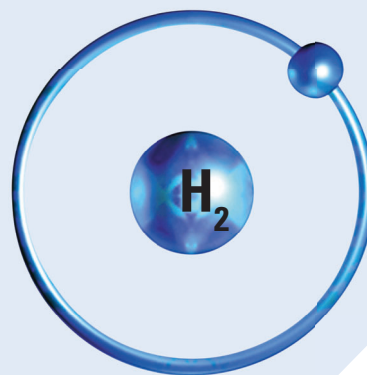

Helium (He) and Inert Pure Gases

Teledyne's full offering of capillary column phase material and detectors allow for comprehensive analysis of most impurities in inert gas from ppb to percent level using up to 2 columns and two detectors. The model CS incorporates seamless column switching in the inlet compartment to perform selective column selection, as well as offering heart-cut and trap / bypass capability.



Environmental Monitoring

Teledyne's 4000 Series is uniquely suited to meet the stringent requirements of monitoring ambient air for harmful or problematic gas releases including acetylene, benzene, BTEX, oxygenates, hydrogen sulfide (H₂S), sulfurs and countless other gases.



Sensitivity

Many configurations of the 4000 Series GC can achieve detection limits at the parts-per billion level. The Model GS-T configuration further increases that sensitivity by leveraging a preconcentrating trap module to improve detectability into the parts-per-trillion level.

Ultra-Fast

By incorporating patented direct heating of stainless steel and reducing thermal mass, the 4000 series ramps column temperatures and cools down faster than conventional GCs. Faster analysis for critical safety monitoring is accomplished by not using more of the column than needed and minimizing volumes. Additionally, most applications can be done in under 5 minutes.

Flexibility

With a full suite of column, detector and switching valve options, a single 4000 series can be configured to perform extensive analyses of inert, permanent and hydrocarbon gases with a single unit.

Typical power requirements do not exceed 300 watts. This combined with most detectors accommodating hydrogen or helium carrier with low flow requirements means the utilities needed to run the units are minimized.

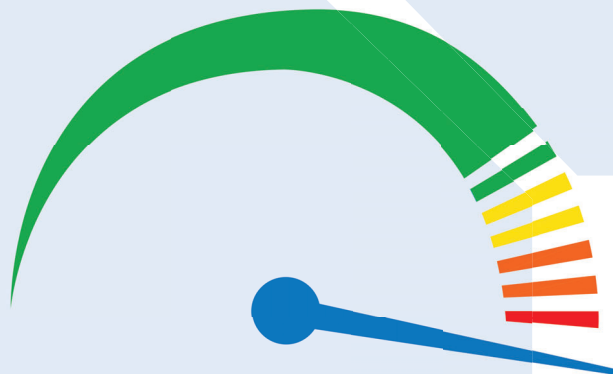

The 4000 series GC's are faster, smarter and easier than traditional chromatographs and come with the following capabilities:

- Single column module lengths up to 16 meters
- Dual column module with units 32 meters total length
- Dual detector configurations
- Dual column heart-cut or trap/bypass configurations

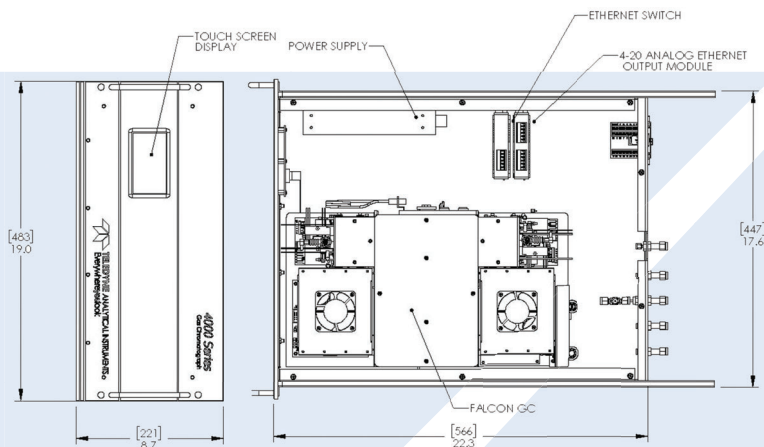
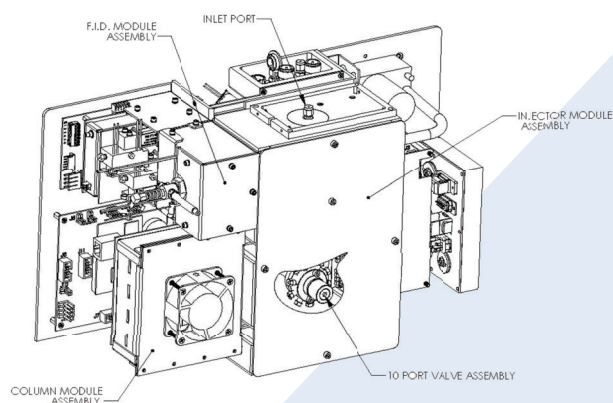

Faster

With analytical cycles faster than traditional chromatographs, the 4000 series GC vastly increases responsiveness for the data consumer. Less time is spent waiting on results which means more productivity and timely control of measured processes. Product output, quality and profitability are increased while field analysis becomes more practical and reliable.

Smarter

Using modern computing with standard operating systems and software, the 4000 series GC frees valuable technical resources from the daily grind of interpreting and validating chromatographic results. State-of-the-art Chromperfect® GC operating software is built in and LineUp™ software virtually eliminates misidentification of components and drastically reduces the need for expensive calibration sample runs. Less time spent calibrating the analyzer means more time spent on economically valuable diagnostics, most notably measured process deviations from the set-point.

Easier

Teledyne's patented direct heating of the temperature-programmed column modules allow the 4000 series to avoid the complicated and troublesome valve schemes used in isothermal process analyzers. The 4000 Series GC's patented overall modular design also makes diverse application engineering and maintenance easier, as column and detector modules are readily changed out as needed.

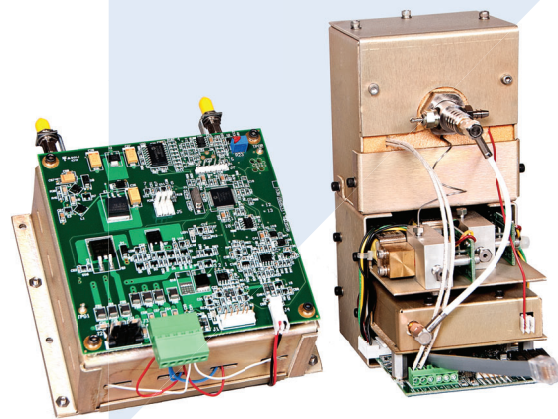
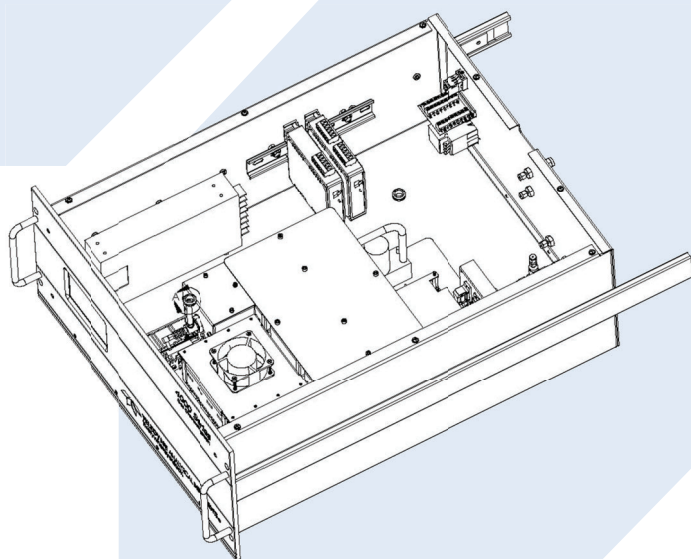

4000 Series Gas Chromatograph

The 4000 Series Gas Chromatograph is a widely applicable, fast programmed temperature gas chromatograph consisting of:

- A sample vacuum pump to draw in gases at near-ambient temperatures and pressures. Typically used in ambient air monitoring.
- One or two column modules that can be run simultaneously either in a series or parallel to one or two detectors
- Teledyne's patented direct heating, precalibrated and individually programmed temperature column modules, enabling dual simultaneous analysis on the same sample, using different separation media and temperature profiles for maximum selectivity.
- Flame Ionization Detection, Thermal Conductivity Detection, Flame Photometric and Dielectric Barrier Discharge (DBD) detectors are available.
- A maximum detector operating temperature of 662°F (350°C).
- System configurations enabling measurement of fixed gases up through components with boiling points equivalent to n - C50.
- Samples that can be gas or liquid phase and be directly injected into the split/split less injection port. Optional SP/ME and other sampling methods are available.
- Chromperfect® chromatography data system running on a Windows PC.



Chromperfect® Seven™

What is Chromperfect® Seven?

Chromperfect® Seven is a new PC based data system designed to meet the needs and budgets of smaller laboratories, offers much more than expensive competitive systems and shares the same core software as any other Chromperfect® system. It has a fully featured system with ease of use at the forefront of the product's innovative design.

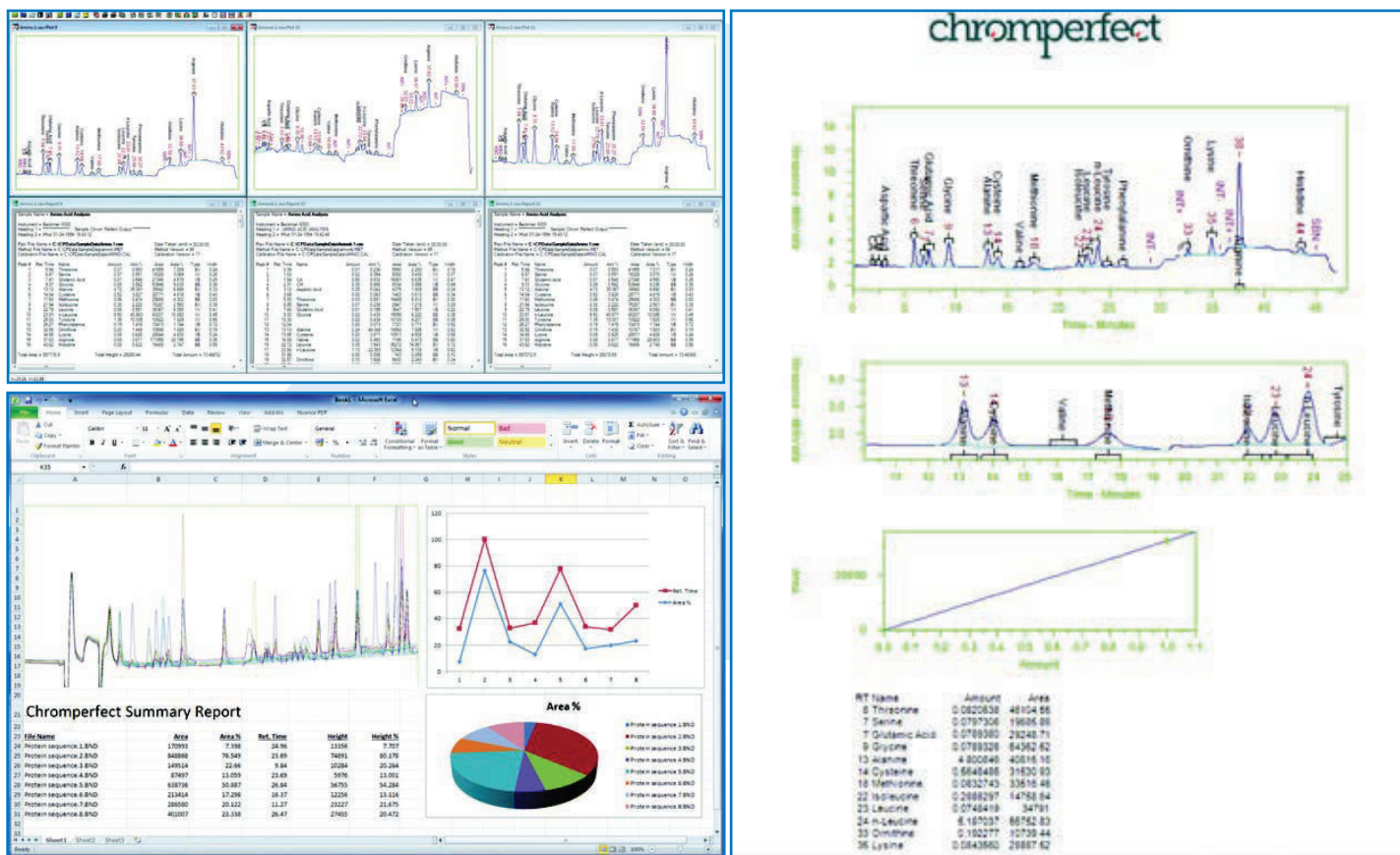

Features

Easy to set-up, learn and use - New users can install the software, connect the instruments and be ready to start reporting data in less than 30 minutes.

Flexible and powerful data acquisition - Chromperfect® has no hardware axe to grind, allowing customers to utilize new and legacy instrumentation from any manufacturer using one software system. Additionally, it allows you to start processing your data and get results before run time is even finished.

Data Analysis - Chromperfect® provides the freedom to choose how many chromatograms are displayed and analyzed at a time. Every chromatogram displayed in the analysis program can even be individually adjusted for plotting, integration and reporting.

Documentation - Fully documented methods, sequences and reports, including instrument run logs.

Fully integrated System Manager - Offers complete control over user privileges and system access to protect important data and files.

Specifications

Available Detectors	Flame Ionization (FID), Thermal Conductivity (TCD), Flame Photometric (FPD), Dielectric Barrier Discharge (DBD) (configured as helium ionization)
Detector/Column Configurations	<p>101: Single column (2-16 meters), single detector</p> <p>201: Dual column (4-32 meters), single detector in series</p> <p>301: Dual column (2-16 meters), dual detector in parallel</p> <p>CS: Dual column (2-16 meters), single or dual detector with column switching valve</p> <p>GS: Single or dual column (2-32 meters) with sample loop, single or dual detector and optional sample pump</p> <p>GS-T: Single or dual column (2-32 meters) with preconcentration trap module, single or dual detector and optional sample pump</p>
Repeatability	< ± 1% Relative Standard Deviation (RSD)
Temperature	<p>Operating: 32 to 95°F (0° to 35°C)</p> <p>Storage: -4 to 140°F (-20° to 60°C)</p>
Utilities	<p>Carrier Gas (application-dependent)</p> <p>UHP hydrogen and zero air (99.999% pure) (for FID and FPD only)</p>
Power	100-240 VAC 50/60 Hz
Data Management	<p>Front-panel touchscreen for GC initialization and manual sampling functions</p> <p>All other functions via TCP/IP Ethernet to external PC with Chromperfect® Seven software (Windows® 10 or higher OS required)**</p> <p>**Windows is a registered trademark of The Microsoft Corporation</p>
Outputs	<p>Up to 6 x 4-20 mA DC (isolated) outputs</p> <p>MODBUS-TCP (optional)</p>
Dimensions	<p>8.7"H x 19.0"W x 22.3"D</p> <p>(221 x 483 x 566 mm)</p>



TELEDYNE
ANALYTICAL INSTRUMENTS
 Everywhere you look™

CALIFORNIA OFFICE
 CITY OF INDUSTRY, CA
 UNITED STATES OF AMERICA (USA)
 TEL: +1 626.934.1500

COLORADO OFFICE
 ENGLEWOOD, CO
 UNITED STATES OF AMERICA (USA)
 TEL: +1 303.792.3300

MIDDLE EAST OFFICE
 SHARJAH
 UNITED ARAB EMIRATES (UAE)
 TEL: +971.6557.9727

SOUTHEAST ASIA OFFICE
 PETALING JAYA
 MALAYSIA
 TEL: +603.7805.7712

ASK_TAI@TELEDYNE.COM
WWW.TELEDYNE-AI.COM

GOTML@TELEDYNE.COM
WWW.TELEDYNE-ML.COM