

Use and Disclosure of Data
Information contained herein is classified as EAR99 under the
U.S. Export Administration Regulations.
Export, reexport or diversion contrary to U.S. law is prohibited.

OPERATING INSTRUCTIONS FOR

Model 3020P

Percent Oxygen Analyzer

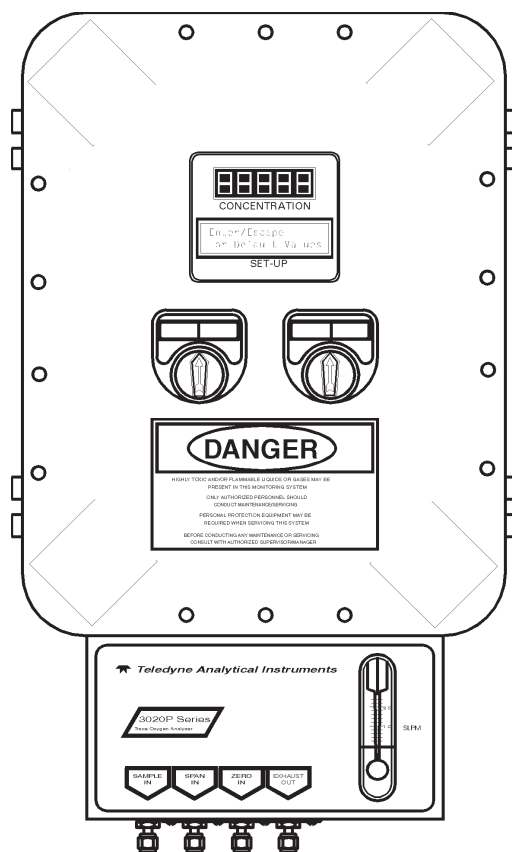

DANGER

HIGHLY TOXIC AND OR FLAMMABLE LIQUIDS OR GASES MAY BE PRESENT IN THIS MONITORING SYSTEM.

PERSONAL PROTECTIVE EQUIPMENT MAY BE REQUIRED WHEN SERVICING THIS SYSTEM.

HAZARDOUS VOLTAGES EXIST ON CERTAIN COMPONENTS INTERNALLY WHICH MAY PERSIST FOR A TIME EVEN AFTER THE POWER IS TURNED OFF AND DISCONNECTED.

ONLY AUTHORIZED PERSONNEL SHOULD CONDUCT MAINTENANCE AND/OR SERVICING. BEFORE CONDUCTING ANY MAINTENANCE OR SERVICING CONSULT WITH AUTHORIZED SUPERVISOR/MANAGER.

P/N M66066
4/22/15

Copyright ©2015 Teledyne Analytical Instruments

All Rights Reserved. No part of this manual may be reproduced, transmitted, transcribed, stored in a retrieval system, or translated into any other language or computer language in whole or in part, in any form or by any means, whether it be electronic, mechanical, magnetic, optical, manual, or otherwise, without the prior written consent of Teledyne Analytical Instruments, 16830 Chestnut Street, City of Industry, CA 91748.

Warranty

This equipment is sold subject to the mutual agreement that it is warranted by us free from defects of material and of construction, and that our liability shall be limited to replacing or repairing at our factory (without charge, except for transportation), or at customer plant at our option, any material or construction in which defects become apparent within one year from the date of shipment, except in cases where quotations or acknowledgements provide for a shorter period. Components manufactured by others bear the warranty of their manufacturer. This warranty does not cover defects caused by wear, accident, misuse, neglect or repairs other than those performed by Teledyne or an authorized service center. We assume no liability for direct or indirect damages of any kind and the purchaser by the acceptance of the equipment will assume all liability for any damage which may result from its use or misuse.

We reserve the right to employ any suitable material in the manufacture of our apparatus, and to make any alterations in the dimensions, shape or weight of any parts, in so far as such alterations do not adversely affect our warranty.

Important Notice

This instrument provides measurement readings to its user, and serves as a tool by which valuable data can be gathered. The information provided by the instrument may assist the user in eliminating potential hazards caused by his process; however, it is essential that all personnel involved in the use of the instrument or its interface, with the process being measured, be properly trained in the process itself, as well as all instrumentation related to it.

The safety of personnel is ultimately the responsibility of those who control process conditions. While this instrument may be able to provide early warning of imminent danger, it has no control over process conditions, and it can be misused. In particular, any alarm or control systems installed must be tested and understood, both as to how they operate and as to how they can be defeated. Any safeguards required such as locks, labels, or redundancy, must be provided by the user or specifically requested of Teledyne at the time the order is placed.

Therefore, the purchaser must be aware of the hazardous process conditions. The purchaser is responsible for the training of personnel, for providing hazard warning methods and instrumentation per the appropriate standards, and for ensuring that hazard warning devices and instrumentation are maintained and operated properly.

Teledyne Analytical Instruments, the manufacturer of this instrument, cannot accept responsibility for conditions beyond its knowledge and control. No statement expressed or implied by this document or any information disseminated by the manufacturer or its agents, is to be construed as a warranty of adequate safety control under the user's process conditions.

Specific Model Information

The instrument for which this manual was supplied may incorporate one or more options not supplied in the standard instrument. Commonly available options are listed below, with check boxes. Any that are incorporated in the instrument for which this manual is supplied are indicated by a check mark in the box.

Instrument Serial Number: _____

Options Included in the Instrument with the Above Serial Number:

- 3020P-C:** In addition to all standard features, this model also has separate ports for zero and span gases, and built-in control valves. The internal valves are entirely under the control of the 3020P electronics, to automatically switch between gases in synchronization with the analyzer's operations
- 3020P-F:** Includes flame arrestors for Group C and D service.
- 3020P-G:** Includes flame arrestors for Groups C and D service, plus gas control valves as in –C option, above
- 3020P-H:** Includes flame arrestors for Group B (hydrogen) service.
- 3020P-I:** Includes flame arrestors for Group B (hydrogen) service, plus gas control valves as in –C option, above.
- 3020P-S:** Stainless steel sampling system and cell block.
- 3020P-M:** 4-20 mA dc Signal and Range ID outputs (in addition to the standard dc voltage outputs).

- Cell Class:** _____ (Class B-1 is standard.)
Enter cell class here.

Table of Contents

1 Introduction

1.1 Overview	1-1
1.2 Typical Applications	1-1
1.3 Main Features of the Analyzer	1-1
1.4 Model Designations	1-2
1.5 Operator Interface	1-3
1.5.1 UP/DOWN Switch	1-4
1.5.2 ESCAPE/ENTER Switch	1-5
1.5.3 Displays	1-5
1.6 Recognizing Difference Between LCD & VFD	1-6
1.7 Rear Panel (Equipment Interface)	1-6
1.7.1 Electrical Connector Panel	1-6
1.7.2 Gas Connector Panel	1-8

2 Operational Theory

2.1 Introduction	2-1
2.2 Micro-Fuel Cell Sensor	2-1
2.2.1 Principles of Operation	2-1
2.2.2 Anatomy of a Micro-Fuel Cell	2-2
2.2.3 Electrochemical Reactions	2-3
2.2.4 The Effect of Pressure	2-4
2.2.5 Calibration Characteristics	2-4
2.2.6 Micro-Fuel Cell "Class"	2-5
2.3 Sample System	2-6
2.4 Electronics and Signal Processing	2-7
2.5 Temperature Control	2-9

3 Installation

3.1 Unpacking the Analyzer	3-1
3.2 Mounting the Analyzer	3-1
3.3 Electrical Connections	3-3
3.3.1 Primary Input Power	3-4
3.3.2 Fuse Installation	3-4
3.3.3 Analog Outputs	3-4
3.3.4 Alarm Relays	3-6
3.3.5 Digital Remote Cal Inputs	3-7
3.3.6 Range ID Relays	3-9
3.3.7 Network I/O	3-9
3.3.8 RS-232 Port	3-9
3.3.9 Remote Sensor and Solenoid Valves	3-10

3.4	Installing the Micro-Fuel Cell	3-12
3.5	Gas Connections	3-12
3.6	Testing the System	3-13

4 Operation

4.1	Introduction	4-1
4.2	Using the Data Entry and Function Buttons	4-1
4.2.1	Mode/Function Selection	4-2
4.2.1.1	Analysis Mode	4-2
4.2.1.2	Setup Mode	4-2
4.2.2	Data Entry	4-4
4.2.2.1	ENTER	4-4
4.2.2.2	ESCAPE	4-4
4.3	The AUTO-CAL Function	4-5
4.4	The PWD Function	4-5
4.4.1	Entering the Password	4-6
4.4.2	Installing or Changing the Password	4-7
4.5	The LOGOUT Function	4-8
4.6	The VERSION Screen	4-8
4.7	The SELF TEST Function	4-9
4.8	The SPAN Functions	4-9
4.8.1	Cell Failure	4-10
4.8.2	Span Cal	4-11
4.8.2.1	Auto Mode Spanning	4-11
4.8.2.2	Manual Mode Spanning	4-11
4.9	The ALARMS Function	4-12
4.10	The RANGE Function	4-14
4.10.1	Setting the Analog Output Ranges	4-15
4.10.2	Automatic Ranging	4-15
4.10.3	Fixed Range Analysis	4-15
4.11	The CONTRAST Function	4-16
4.11.1	At Powerup	4-16
4.11.2	During Operation	4-16
4.12	The STANDBY Function	4-17
4.13	The SENSOR Function	4-17
4.14	The <i>Analysis Mode</i>	4-17

Maintenance

5.1	Routine Maintenance	5-1
5.2	Major Internal Components	5-1
5.3	Cell Replacement	5-2
5.3.1	Storing and Handling Replacement Cells	5-2

5.3.2	When to Replace a Cell	5-3
5.3.3	Removing the Micro-Fuel Cell	5-4
5.3.4	Installing a New Micro-Fuel Cell	5-6
5.2.5	Cell Warranty	5-6
5.4	Fuse Replacement.....	5-7
5.5	System Self Diagnostic Test.....	5-7

Appendix

A-1	Specifications	A-1
A-2	Recommended 2-Year Spare Parts List	A-3
A-3	Drawing List	A-4
A-4	Application Notes on Restrictors, Pressures and Flow ..	A-5
A-5	The Zero Functions	A-8

Introduction

1.1 Overview

The Teledyne Analytical Instruments Model 3020P Percent Oxygen Analyzer is a versatile microprocessor-based instrument for detecting oxygen in a variety of gases. This manual covers the Model 3020P, percent oxygen, explosion-proof, bulkhead-mount units only.

1.2 Typical Applications

A few typical applications of the Model 3020P are:

- Monitoring inert gas blanketing
- Air separation and liquefaction
- Chemical reaction monitoring
- Semiconductor manufacturing
- Petrochemical process control
- Quality assurance
- Gas analysis certification.

1.3 Main Features of the Analyzer

The Model 3020P Percent Oxygen Analyzer is sophisticated yet simple to use. The main features of the analyzer include:

- A 2-line alphanumeric display screen, driven by microprocessor electronics, that continuously prompts and informs the operator.
- High resolution, accurate readings of oxygen content from low % levels through 100%. Large, bright, meter readout.
- Stainless steel cell block.

- Advanced Micro-Fuel Cell for percent analysis. Standard cell has six month warranty and expected lifetime of eight months.
- Versatile analysis over a wide range of applications.
- Microprocessor based electronics: 8-bit CMOS microprocessor with 32 kB RAM and 128 kB ROM.
- Three user definable output ranges (from 0-1 % through 0-100 %) allow best match to users process and equipment.
- Air-calibration range for convenient spanning at 20.9 %.
- Auto Ranging allows analyzer to automatically select the proper preset range for a given measurement. Manual override allows the user to lock onto a specific range of interest.
- Two adjustable concentration alarms and a system failure alarm.
- Extensive self-diagnostic testing, at startup and on demand, with continuous power-supply monitoring.
- RS-232 serial digital port for use with a computer or other digital communication device.
- Analog outputs for concentration and range identification. (0-1 V dc standard, and isolated 4–20 mA dc optional.)

1.4 Model Designations

- 3020P:** Standard model.
- 3020P-C:** In addition to all standard features, this model also has separate ports for zero and span gases, and built-in control valves. The internal valves are entirely under the control of the 3020P electronics, to automatically switch between gases in synchronization with the analyzer's operations
- 3020P-F:** Includes flame arrestors for Groups C and D.
- 3020P-G:** Includes flame arrestors for Groups C and D, & -C option.
- 3020P-H:** Includes flame arrestors for Group B (Hydrogen service).
- 3020P-I:** Includes flame arrestors for Group B, & -C option.
- 3020P-S:** Stainless steel cell block and sampling system.
- 3020P-M:** 4-20 mA dc Signal and Range ID outputs, in addition to the standard voltage outputs.

All of the above options are available in combination.

1.5 Operator Interface

All controls and displays on the standard 3020P are accessible from outside the housing. The instrument has two simple operator controls. The operator has constant feedback from the instrument through an alphanumeric display, a digital oxygen meter, and a sample flow meter. The displays and controls are described briefly here and in greater detail in chapter 4. See Figure 1-1.

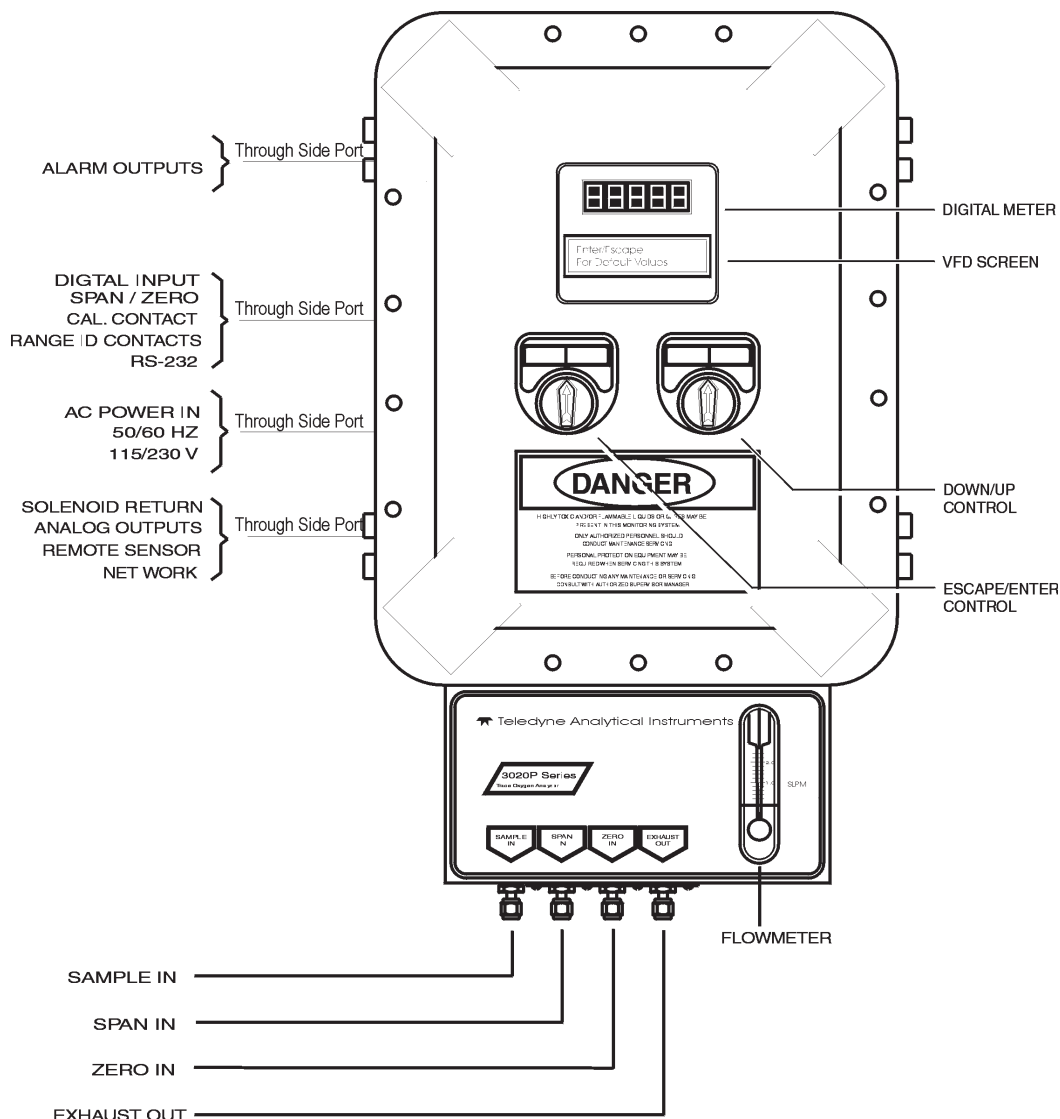

Figure 1-1: Model 3020P Controls, Indicators, and Connectors

1.5.1 UP/DOWN Switch

Functions: The UP/DOWN switch is used to select the function to be performed. Choose UP or DOWN to scroll through the following list of twelve functions:

- **Auto-Cal** Set up an automatic calibration sequence.
- **PWD** Install a password to protect your analyzer setup.
- **Logout** Locks Setup Mode.
- **Version** Displays model and version of analyzer.
- **Self-Test** Runs internal diagnostic program, displays results.

Contrast Function is **DISABLED**•
(Refer to Section 1.6)



- **Span** Span calibrate the analyzer.
- **Zero** Zero calibrate the analyzer.
- **Alarms** Set the alarm setpoints and attributes.
- **Range** Set up the 3 user definable ranges for the instrument.
- **Contrast** Adjust LCD contrast.
- **Standby** Leave analyzer powered, but no outputs or displays.
- **Sensor** Check sensor output in μA .

WARNING: THE POWER CABLE MUST BE DISCONNECTED TO FULLY REMOVE POWER FROM THE INSTRUMENT.

Subfunctions: Once a Function is entered, the UP/DOWN switch is used to select between any subfunctions displayed on the VFD screen.

Parameter values: When modifiable values are displayed on the VFD, the UP/DOWN switch can be used to increment or decrement the values.

1.5.2 ESCAPE/ENTER Switch

Data Entry: The ESCAPE/ENTER switch is used to input data, from the alphanumeric VFD screen into the instrument:

- **Escape** Moves VFD display back to the previous screen in a series. If none remains, returns to the *Analyze* screen.
With subfunction selected, moves VFD back through items on screen, to first item, then moves VFD to previous display.
- **Enter** With a Subfunction Selected: Moves VFD on to the next screen in a series. If none remains, returns to the *Analyze* screen.
With a Value Selected: Enters the value into the analyzer as data. Advances VFD to next operation.

(See Chapter 4 for details.)

1.5.3 Displays

Digital Meter Display: The meter display is a LED device that produces large, bright, 7-segment numbers that are legible in any lighting. It produces a continuous readout from 0-100 %. It is accurate across all analysis ranges without the discontinuity inherent in analog range switching.

Alphanumeric Interface Screen: The backlit VFD screen is an easy-to-use interface from operator to analyzer. It displays values, options, and messages that give the operator immediate feedback.

Flowmeter: Monitors the flow of gas past the sensor. Readout is 0.2 to 2.4 standard liters per minute (SLPM).

1.6 Recognizing Difference Between LCD & VFD

LCD has *GREEN* background with *BLACK* characters. VFD has *DARK* background with *GREEN* characters. In the case of VFD - *NO CONTRAST ADJUSTMENT IS NEEDED*.

1.7 Equipment Interface

1.7.1 Electrical Connector Panel

The electrical connector panel, shown in Figure 1-2, contains the electrical connections for external inlets and outlets. The connectors are described briefly here and in detail in the *Installation* chapter of this manual.

CAUTION: *The power cable must be disconnected to fully remove power from the instrument.*

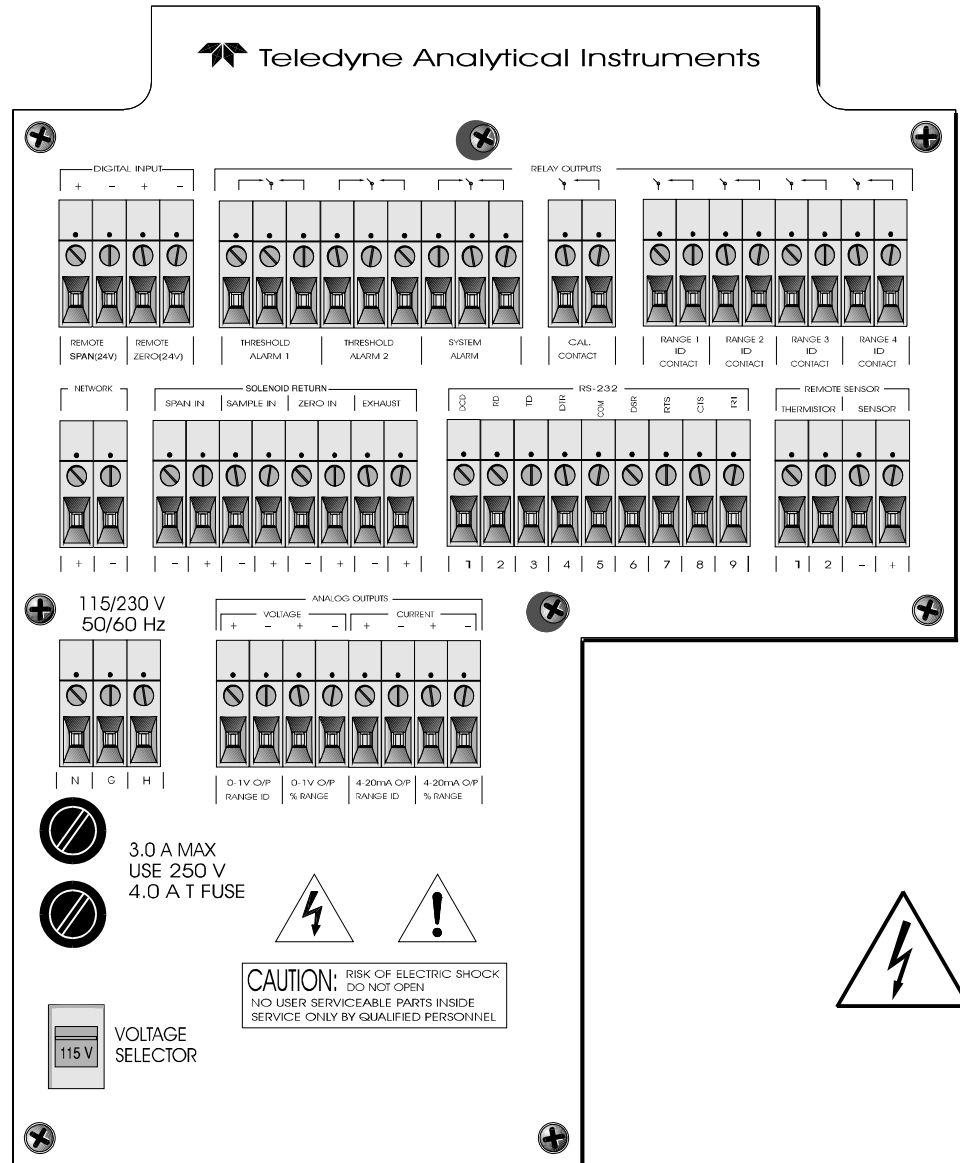

Figure 1-2: Electrical Connector Panel

Electrical Connections: The electrical connections on the electrical connector panel are described briefly here, and in more detail in chapter 3 *Installation*.

- **Power Connection** 115 or 230 V dc, 50 or 60 Hz.
- **Analog Outputs** 0-1 V dc concentration plus 0-1 V dc range ID. Additional, isolated 4-20 mA dc plus 4-20 mA dc range ID available.
- **Alarm Connections** 2 concentration alarms and 1 system alarm.

- **RS-232 Port** Serial digital concentration signal output and control input.
- **Remote Valves** Used for controlling external solenoid valves, if desired.
- **Remote Sensor** Used for external sensor and thermocouple, if desired.
- **Remote Span/Zero** Digital inputs allow external control of analyzer calibration.
- **Calibration Contact** To notify external equipment that instrument is being calibrated and readings are not monitoring sample.
- **Range ID Contacts** Four separate, dedicated, range relay contacts. Low, Medium, High, Cal.
- **Network I/O** Serial digital communications for local network access. For future expansion. Not implemented at this printing.

1.7.2 Gas Connector Panel

The gas connector panel, shown in Figure 1-3, contains the gas connections for external inlets and outlets. Those that are optional are shown shaded in the figure. The connectors are described briefly here and in detail in the *Installation* chapter of this manual.

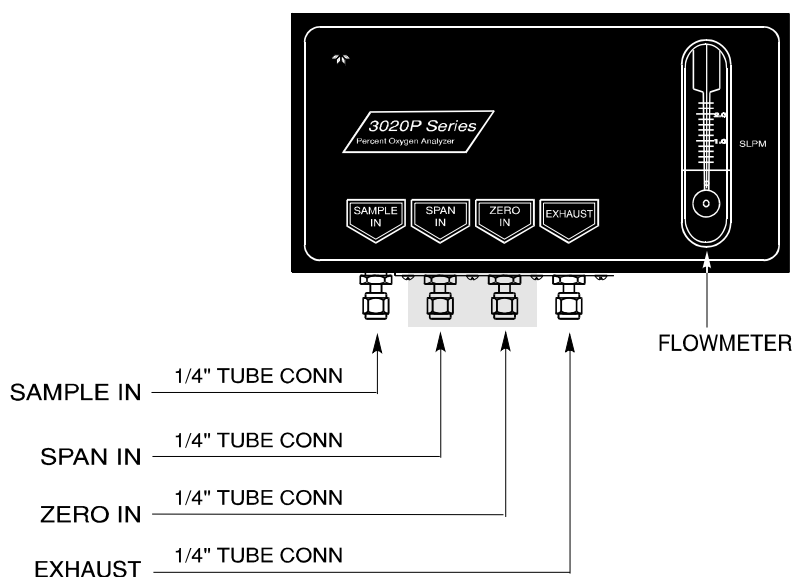

Figure 1-3: Model 3020P Gas Connector Panel

- **Gas Inlet and Outlet** One inlet (must be externally valved) and one exhaust out.

Optional:

- **Calibration Gas Ports** Separate fittings for zero, span and sample gas input, plus internal valves for automatically switching the gases in sync with the 3020 electronics.

Note: If you require highly accurate Auto-Cal timing, use external Auto-Cal control where possible. The internal clock in the Model 3020P is accurate to 2-3 %. Accordingly, internally scheduled calibrations can vary 2-3 % per day.

Operational Theory

2.1 Introduction

The analyzer is composed of three subsystems:

1. Micro-Fuel Cell Sensor
2. Sample System
3. Electronic Signal Processing, Display and Control

The sample system is designed to accept the sample gas and transport it through the analyzer without contaminating or altering the sample prior to analysis. The Micro-Fuel Cell is an electrochemical galvanic device that translates the amount of oxygen present in the sample into an electrical current. The electronic signal processing, display and control subsystem simplifies operation of the analyzer and accurately processes the sampled data. The microprocessor controls all signal processing, input/output and display functions for the analyzer.

2.2 Micro-Fuel Cell Sensor

2.2.1 Principles of Operation

The oxygen sensor used in the Model 3020P series is a Micro-Fuel Cell designed and manufactured by Analytical Instruments. It is a sealed plastic disposable electrochemical transducer.

The active components of the Micro-Fuel Cell are a cathode, an anode, and the 15% aqueous KOH electrolyte in which they are immersed. The cell converts the energy from a chemical reaction into an electrical current in an external electrical circuit. Its action is similar to that of a battery.

There is, however, an important difference in the operation of a battery as compared to the Micro-Fuel Cell: In the battery, all reactants are stored within the cell, whereas in the Micro-Fuel Cell, one of the reactants (oxygen)

comes from outside the device as a constituent of the sample gas being analyzed. The Micro-Fuel Cell is therefore a hybrid between a battery and a true fuel cell. (All of the reactants are stored externally in a true fuel cell.)

2.2.2 Anatomy of a Micro-Fuel Cell

The Micro-Fuel Cell is a cylinder only 1¼ inches in diameter and 1¼ inches thick. It is made of an extremely inert plastic, which can be placed confidently in practically any environment or sample stream. It is effectively sealed, although one end is permeable to oxygen in the sample gas. The other end of the cell is a contact plate consisting of two concentric foil rings. The rings mate with spring-loaded contacts in the sensor block assembly and provide the electrical connection to the rest of the analyzer. Figure 2-1 illustrates the external features.

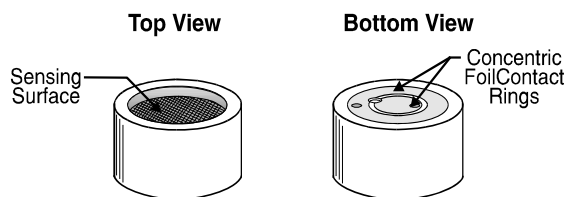

Figure 2-1: Micro-Fuel Cell

Refer to Figure 2-2, *Cross Section of a Micro-Fuel Cell*, which illustrates the following internal description.

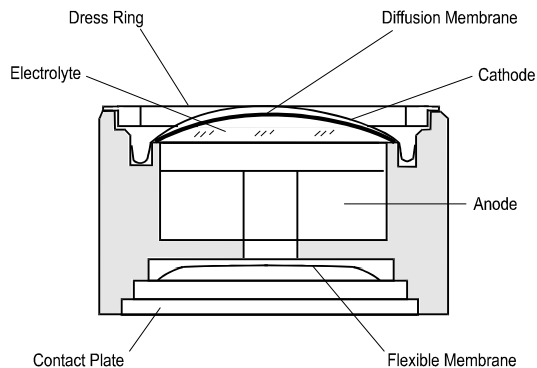

Figure 2-2. Cross Section of a Micro-Fuel Cell (not to scale)

At the top end of the cell is a diffusion membrane of Teflon, whose thickness is very accurately controlled. Beneath the diffusion membrane lies the oxygen sensing element—the cathode—with a surface area almost 4 cm². The cathode has many perforations to ensure sufficient wetting of the upper surface with electrolyte, and it is plated with an inert metal.

The anode structure is below the cathode. It is made of lead and has a proprietary design which is meant to maximize the amount of metal available for chemical reaction.

At the rear of the cell, just below the anode structure, is a flexible membrane designed to accommodate the internal volume changes that occur throughout the life of the cell. This flexibility assures that the sensing membrane remains in its proper position, keeping the electrical output constant.

The entire space between the diffusion membrane, above the cathode, and the flexible rear membrane, beneath the anode, is filled with electrolyte. Cathode and anode are submerged in this common pool. They each have a conductor connecting them to one of the external contact rings on the contact plate, which is on the bottom of the cell.

2.2.3 Electrochemical Reactions

The sample gas diffuses through the Teflon membrane. Any oxygen in the sample gas is reduced on the surface of the cathode by the following HALF REACTION:



(Four electrons combine with one oxygen molecule—in the presence of water from the electrolyte—to produce four hydroxyl ions.)

When the oxygen is reduced at the cathode, lead is simultaneously oxidized at the anode by the following HALF REACTION:

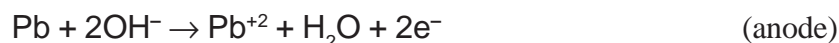

(Two electrons are transferred for each atom of lead that is oxidized. Therefore it takes two of the above anode reactions to balance one cathode reaction and transfer four electrons.)

The electrons released at the surface of the anode flow to the cathode surface when an external electrical path is provided. The current is proportional to the amount of oxygen reaching the cathode. It is measured and used to determine the oxygen concentration in the gas mixture.

The overall reaction for the fuel cell is the SUM of the half reactions above, or:

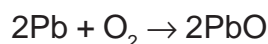

(These reactions will hold as long as no gaseous components capable of oxidizing lead—such as iodine, bromine, chlorine and fluorine—are present in the sample.)

The output of the fuel cell is limited by (1) the amount of oxygen in the cell at the time and (2) the amount of stored anode material.

In the absence of oxygen, no current is generated.

2.2.4 The Effect of Pressure

In order to state the amount of oxygen present in the sample as a percentage of the gas mixture, it is necessary that the sample diffuse into the cell under constant pressure.

If the total pressure increases, the rate that oxygen reaches the cathode through the diffusing membrane will also increase. The electron transfer, and therefore the external current, will increase, even though the oxygen concentration of the sample has not changed. It is therefore important that the sample pressure at the fuel cell (usually vent pressure) remain relatively constant between calibrations.

2.2.5 Calibration Characteristics

Given that the total pressure of the sample gas on the surface of the Micro-Fuel Cell input is constant, a convenient characteristic of the cell is that the current produced in an external circuit is directly proportional to the rate at which oxygen molecules reach the cathode, and this rate is directly proportional to the concentration of oxygen in the gaseous mixture. In other words it has a linear characteristic curve, as shown in Figure 2-3. Measuring circuits do not have to compensate for nonlinearities.

In addition, since there is zero output in the absence oxygen, the characteristic curve has close to an absolute zero. The cell itself does not need to be zeroed. In practical application, zeroing may still used to compensate for zero offsets in the electronics. (The electronics is zeroed automatically when the instrument power is turned on.)

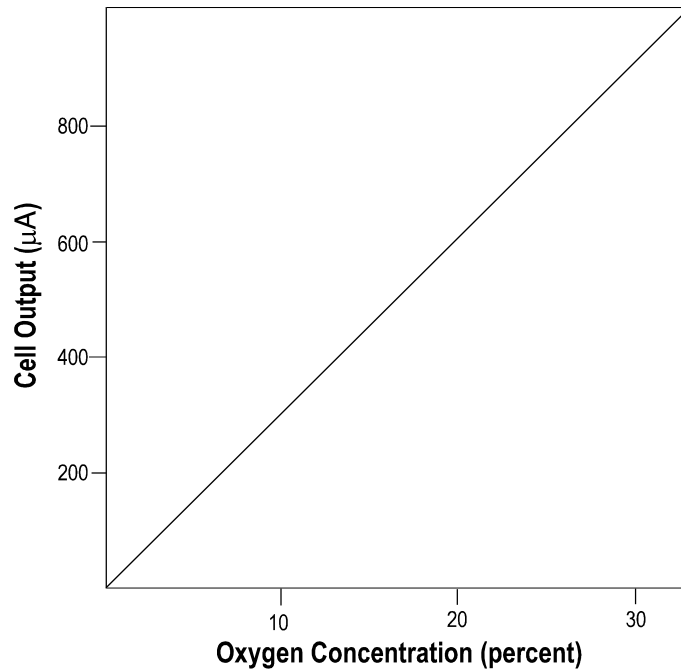

Figure 2-3. Characteristic Input/Output Curve for a Micro-Fuel Cell

2.2.6 Micro-Fuel Cell “Class”

Analytical Instruments manufactures Micro-Fuel Cells with a variety of characteristics to give the best possible performance for any given sample conditions. A few typical Micro-Fuel Cells are listed below with their typical use and electrical specifications.

2.2.6.1 Class A-3 Cell

The class A-3 cell is for use in applications where it is exposed continuously to carbon dioxide concentrations between 1 % and 100 % in the sample gas.

Nominal output in air is 0.20 mA, and 90 % response time is 45 s. Expected life in flue gas is 8 months.

2.2.6.2 Class A-5 Cell

The class A-5 cell is for use in applications where it is exposed intermittently to carbon dioxide concentrations up to 100 % in the sample gas.

Nominal output in air is 0.19 mA, and 90 % response time is 45 s. Expected life in flue gas is 8 months.

2.2.6.3 Class B-1 Cell

The class B-1 cell is for use in applications where it is exposed to less than 0.1 % of carbon dioxide, and where fast response is important.

Nominal output in air is 0.50 mA, and 90 % response time is 7 s. Expected life in air is 8 months.

2.2.6.4 Class B-3 Cell

The class B-3 cell is for use in applications where a slightly longer response time is acceptable in order to have a longer cell life.

Nominal output in air is 0.30 mA, and 90 % response time is 13 s. Expected life in air is 12 months.

2.2.6.5 Class C-3 Cell

The class B-1 cell is for use in applications where it is exposed to less than 0.1 % of carbon dioxide, and where a longer response time is acceptable in order to have a longer cell life.

Nominal output in air is 0.20 mA, and 90 % response time is 30 s. Expected life in air is 18 months.

2.2.6.6 Hydrogen and/or Helium Service

If the sample gas contains 10 % or more hydrogen and/or helium, only “clamp” cells are used. These Micro-Fuel cells are identified by the suffix -C added to the cell class number.

2.3 Sample System

The sample system delivers gases to the Micro-Fuel Cell sensor from the analyzer gas panel inlets. Depending on the mode of operation either sample or calibration gas is delivered.

The Model 3020P sample system is designed and fabricated to ensure that the oxygen concentration of the gas is not altered as it travels through the sample system. The sample encounters almost no dead space. This minimizes residual gas pockets that can interfere with low percent range analysis.

The sample system for the standard instrument incorporates ¼ inch tube fittings for sample inlet and outlet connections at the rear panel. For metric system installations, 6 mm adapters are supplied with each instrument to be used if needed. The sample or calibration gas flowing through the system is monitored by a flowmeter downstream from the cell.

Figure 2-4 is the flow diagram for the sampling system. In the standard instrument, calibration gases (zero and span) can be connected directly to the Sample In port by teeing to the port with appropriate valves. The shaded portions of the diagram show the components added when the -C and/or -F options are ordered. The valves, when supplied, are installed inside the 3020P enclosure and are regulated by the instrument's internal electronics. The flame arrestors, when supplied, are installed in the Gas Connector Panel.

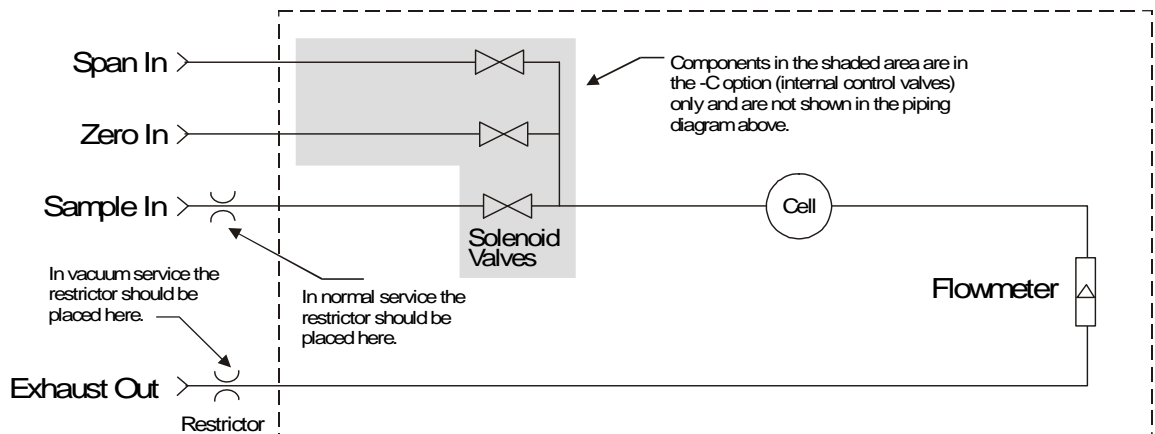

Figure 2-4: Flow Diagram

2.4 Electronics and Signal Processing

The Model 3020P Percent Oxygen Analyzer uses an 8031 microcontroller with 32 kB of RAM and 128 kB of ROM to control all signal processing, input/output, and display functions for the analyzer. System power is supplied from a universal power supply module designed to be compatible with most international power sources. See chapter 5 *Maintenance* for the location of the power supply and the main electronic PC boards.

The signal processing electronics including the microprocessor, analog to digital, and digital to analog converters are located on the motherboard at the bottom of the case. The preamplifier board is mounted on top of the motherboard. These boards are accessible after removing the access panel. Figure 2-5 is a block diagram of the Analyzer electronics.

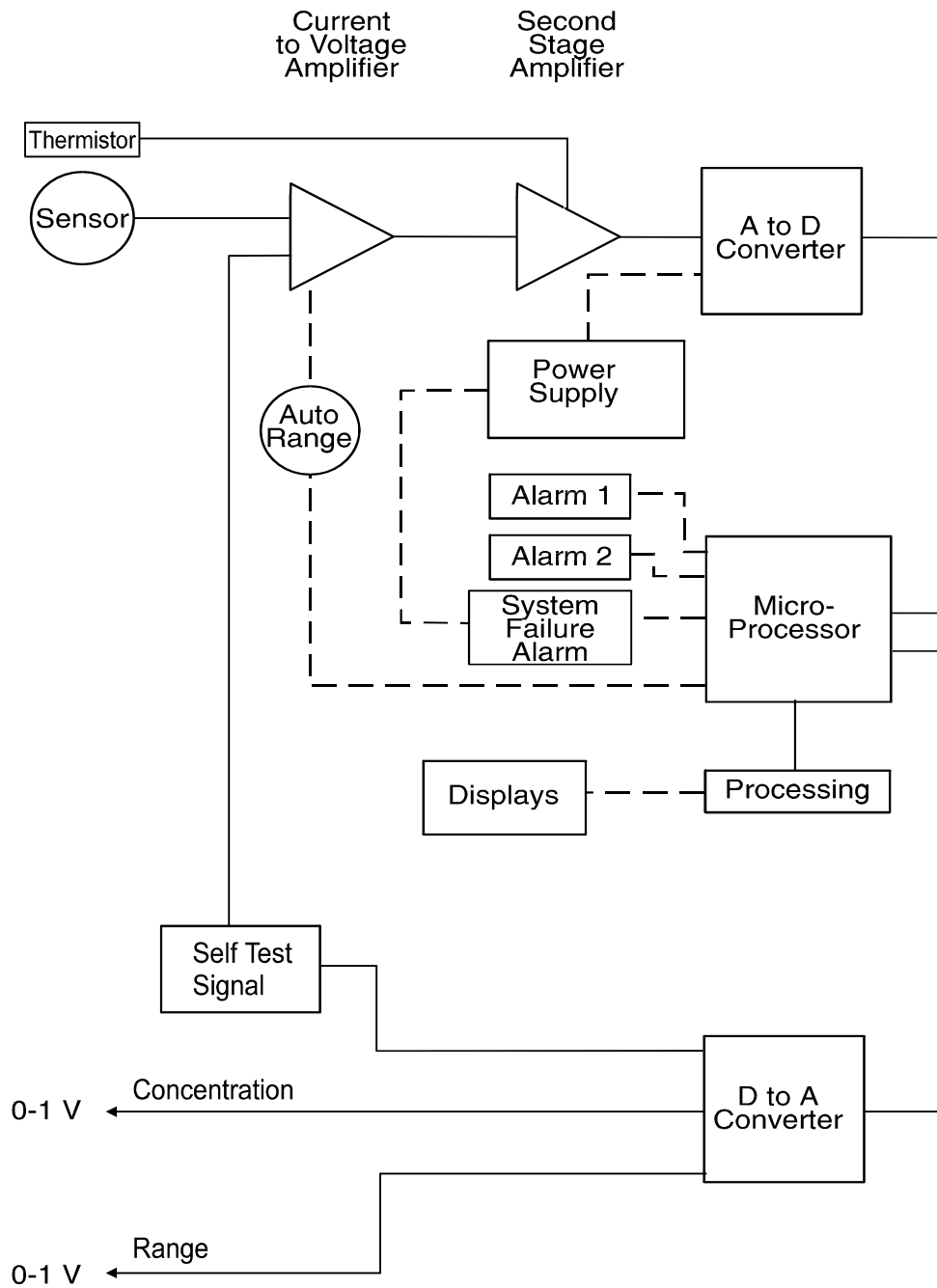

Figure 2-5: Block Diagram of the Model 3020P Electronics

In the presence of oxygen the cell generates a current. A current to voltage amplifier converts this current to a voltage, which is amplified in the second stage amplifier.

The second stage amplifier also supplies temperature compensation for the oxygen sensor output. This amplifier circuit incorporates a thermistor, which is physically located in the cell block. The thermistor is a temperature dependent resistance that changes the gain of the amplifier in proportion to the temperature changes in the block. This change is inversely proportional to the change in the cell output due to the same temperature changes. The result is a signal that is temperature independent. The output from the second stage amplifier is sent to an 18 bit analog to digital converter controlled by the microprocessor.

The digital concentration signal along with input from the control panel is processed by the microprocessor, and appropriate control signals are directed to the display, alarms and communications port. The same digital information is also sent to a 12 bit digital to analog converter that produces the 4-20 mA dc and the 0-1 V dc analog concentration signal outputs, and the analog range ID outputs.

Signals from the power supply are also monitored, and through the microprocessor, the system failure alarm is activated if a malfunction is detected.

2.5 Temperature Control

For accurate analysis this instrument is temperature controlled not to fall beneath a certain temperature. This temperature is 22°F. This is to prevent the sensor from freezing in cold environments.

Installation

Installation of the Model 3020P Analyzer includes:

1. Unpacking
2. Mounting
3. Gas connections
4. Electrical connections
5. Installing the Micro-Fuel Cell
6. Testing the system.

3.1 Unpacking the Analyzer

The analyzer is shipped with all the materials you need to install and prepare the system for operation. Carefully unpack the analyzer and inspect it for damage. Immediately report any damage to the shipping agent.

3.2 Mounting the Analyzer

The Model 3020P is designed for bulkhead mounting in hazardous environments. There are four mounting lugs—one in each corner of the enclosure, as shown in Figure 3-1. The outline drawing, at the back of this manual, gives the mounting hole size and spacing. The drawing also contains the overall dimensions. Do not forget to allow an extra 1³/₈" for the hinges.

Be sure to allow enough space in front of the enclosure to swing the door open—a 16 1/4" radius, as shown in Figure 3-2.

All electrical connections are made via cables which enter the explosion-proof housing through ports in its side. No conduit fittings are supplied. The installer must provide two 3/4" NPT and two 1" NPT adapters and the appropriate sealing conduit.

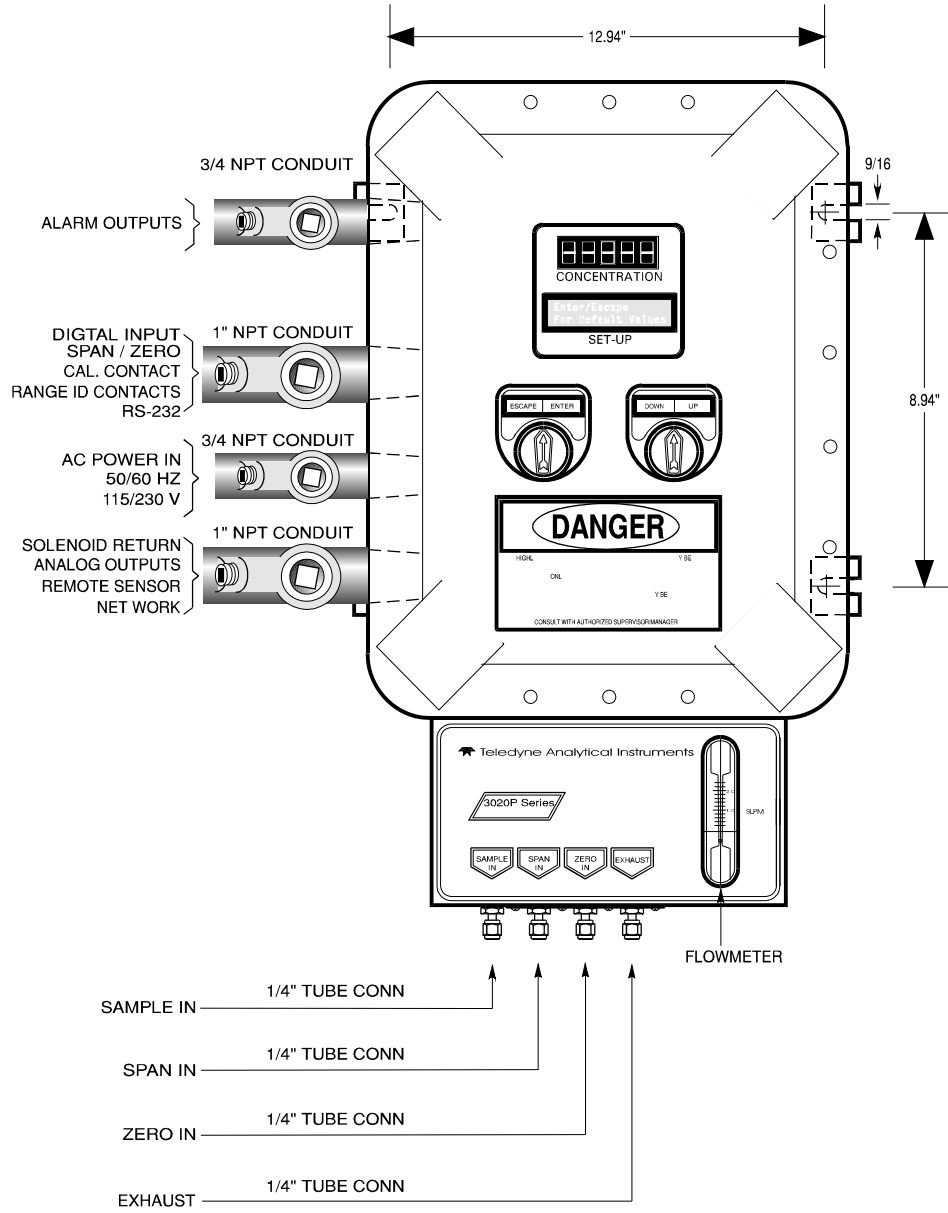

Figure 3-1: Front View of the Model 3020P (Simplified)

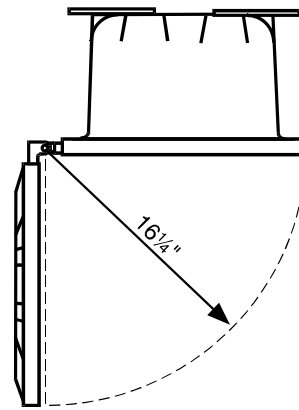
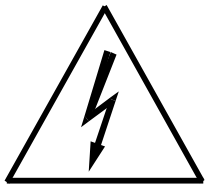

Figure 3-2: Required Front Door Clearance



3.3 Electrical Connections

Figure 3-3 shows the Model 3020P Electrical Connector Panel. There are terminal blocks for connecting power, communications, and both digital and analog concentration outputs.

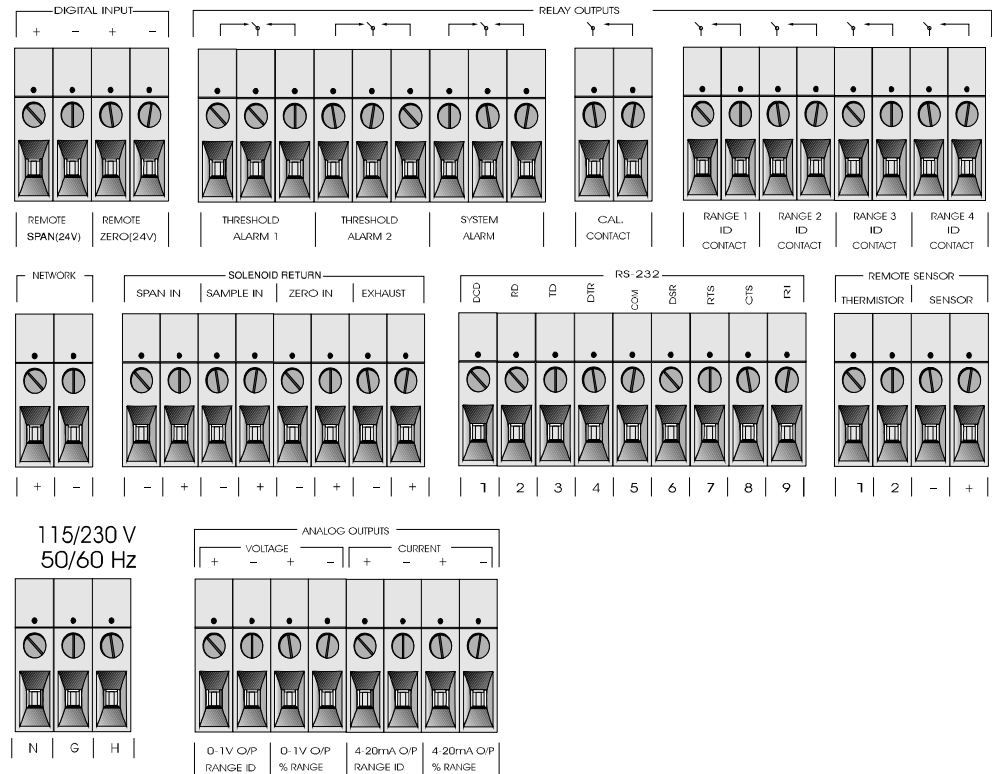

Figure 3-3: Electrical Connector Panel

For safe connections, ensure that no uninsulated wire extends outside of the connectors they are attached to. Stripped wire ends must insert completely into terminal blocks. No uninsulated wiring should be able to come in contact with fingers, tools or clothing during normal operation.

3.3.1 Primary Input Power

The universal power supply requires a 115 or 230 V ac, 50 or 60 Hz power source. The actual input voltage used must show in the window of the VOLTAGE SELECTOR switch **before** the power source is connected. See Figure 3-4 for detailed connections.

DANGER: *Power is applied to the instrument's circuitry as long as the instrument is connected to the power source. The Standby function switches power on or off to the displays and outputs only.*

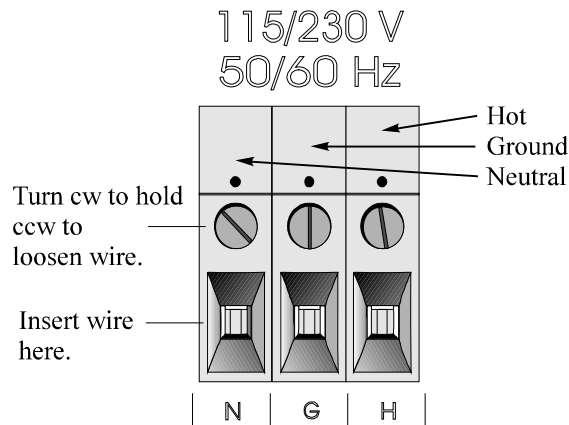

Figure 3-4: Primary Input Power Connections

3.3.2 Fuse Installation

The fuse holders accept 5 x 20 mm, 1.6 A, T type (slow blow) fuses. Fuses are not installed at the factory. Be sure to install the proper fuse as part of installation. (See *Fuse Replacement* in chapter 5, *maintenance*.)

3.3.3 Analog Outputs

There are eight DC output signal connectors on the ANALOG OUTPUTS connector block. There are two connectors per output with the polarity noted. See Figure 3-5.

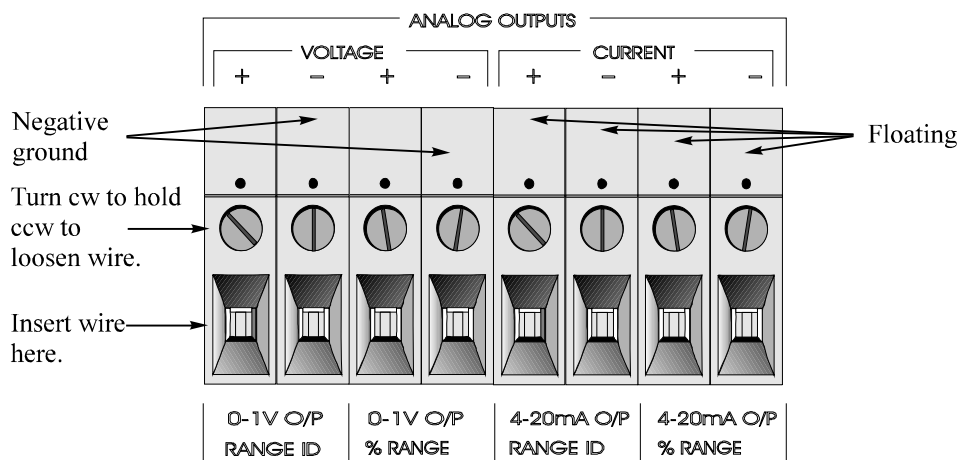

Figure 3-5: Analog Output Connections

The outputs are:

- 0–1 V dc % of Range: Voltage rises linearly with increasing oxygen, from 0 V at 0 % to 1 V at full scale. (Full scale = 100% of programmable range.)
- 0–1 V dc Range ID: 0.25 V = Low Range, 0.5 V = Medium Range, 0.75 V = High Range, 1 V = Air Cal Range.
- 4–20 mA dc % Range: (-M Option) Current increases linearly with increasing oxygen, from 4 mA at 0 % to 20 mA at full scale. (Full scale = 100% of programmable range.)
- 4–20 mA dc Range ID: (-M Option) 8 mA = Low Range, 12 mA = Medium Range, 16 mA = High Range, 20 mA = Air Cal Range.

Examples:

The analog output signal has a voltage which depends on the oxygen concentration AND the currently activated analysis range. To relate the signal output to the actual concentration, it is necessary to know what range the instrument is currently on, especially when the analyzer is in the autoranging mode.

The signal output for concentration is linear over the currently selected analysis range. For example, if the analyzer is set on a range that was defined as 0–10 % O₂, then the output would be as shown in Table 3-1.

Table 3-1: Analog Concentration Output—Example

% O ₂	Voltage Signal Output (V dc)	Current Signal Output (mA dc)
0	0.0	4.0
1	0.1	5.6
2	0.2	7.2
3	0.3	8.8
4	0.4	10.4
5	0.5	12.0
6	0.6	13.6
7	0.7	15.2
8	0.8	16.8
9	0.9	18.4
10	1.0	20.0

To provide an indication of the range, a second pair of analog output terminals are used. They generate a steady preset voltage (or current when using the current outputs) to represent a particular range. Table 3-2 gives the range ID output for each analysis range.

Table 3-2: Analog Range ID Output—Example

Range	Voltage (V)	Current (mA)
LO	0.25	8
MED	0.50	12
HI	0.75	16
CAL (0-25%)	1.00	20

3.3.4 Alarm Relays

There are three alarm-circuit connectors on the alarm relays block (under RELAY OUTPUTS) for making connections to internal alarm relay contacts. Each provides a set of Form C contacts for each type of alarm. Each has both normally open and normally closed contact connections. The contact connections are indicated by diagrams on the connector panel. They are capable of switching up to 3 amperes at 250 V ac into a resistive load. See Figure 3-6.

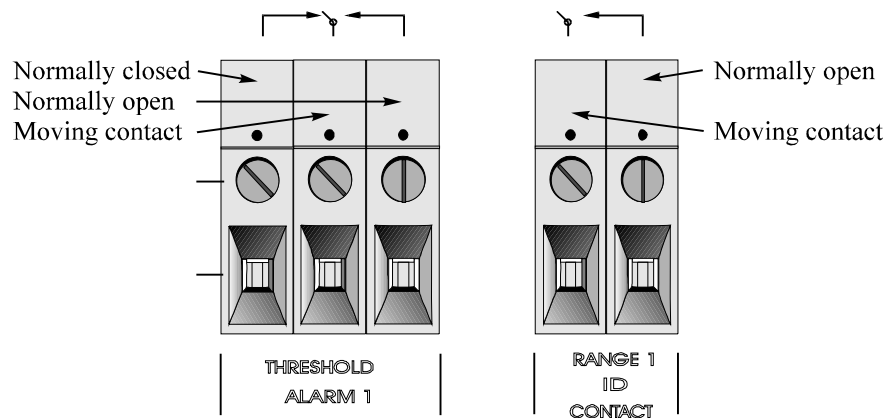

Figure 3-6: Types of Relay Contacts

The connectors are:

- Threshold Alarm 1:
- Can be configured as high (actuates when concentration is above threshold), or low (actuates when concentration is below threshold).
 - Can be configured as failsafe or nonfailsafe.
 - Can be configured as latching or nonlatching.
 - Can be configured out (defeated).
- Threshold Alarm 2:
- Can be configured as high (actuates when concentration is above threshold), or low (actuates when concentration is below threshold).
 - Can be configured as failsafe or nonfailsafe.
 - Can be configured as latching or nonlatching.
 - Can be configured out (defeated).
- System Alarm: Actuates when DC power supplied to circuits is unacceptable in one or more parameters. Permanently configured as failsafe and latching. Cannot be defeated. Actuates if self test fails.
- To reset a System Alarm during installation, disconnect power to the instrument and then reconnect it.

Further detail can be found in chapter 4, section 4-5.

3.3.5 Digital Remote Cal Inputs

Remote Zero and Span Inputs: The REMOTE SPAN and REMOTE ZERO inputs are on the DIGITAL INPUT terminal block. They accept 0 V (OFF) or 24 V dc (ON) for remote control of calibration. (See *Remote Calibration Protocol* below.)

- ZERO:** Floating input. 5 to 24 V input across the + and – terminals puts the analyzer into the *Zero* mode. Either side may be grounded at the source of the signal. 0 to 1 volt across the terminals allows *Zero* mode to terminate when done. A synchronous signal must open and close the external zero valve appropriately. See 3.3.9 *Remote Sensor and Solenoid Valves*. (With the –C option, the internal valves automatically operate synchronously.)
- SPAN:** Floating input. 5 to 24 V input across the + and – terminals puts the analyzer into the *Span* mode. Either side may be grounded at the source of the signal. 0 to 1 volt across the terminals allows *Span* mode to terminate when done. A synchronous signal must open and close the external span valve appropriately. See 3.3.9 *Remote Sensor and Solenoid Valves*. (With the –C option, the internal valves automatically operate synchronously.)

Cal Contact: This relay contact is closed while analyzer is spanning and/or zeroing. (See *Remote Calibration Protocol* below.)

Remote Calibration Protocol: To properly time the Digital Remote Cal Inputs to the Model 3020P Analyzer, the customer's controller must monitor the CAL CONTACT relay.

When the contact is OPEN, the analyzer is analyzing, the Remote Cal Inputs are being polled, and a zero or span command can be sent.

When the contact is CLOSED, the analyzer is already calibrating. It will ignore your request to calibrate, and it will not remember that request.

Once a zero or span command is sent, and acknowledged (contact closes), release it. If the command is continued until after the zero or span is complete, the calibration will repeat and the Cal Relay Contact (CRC) will close again.

For example:

- 1) Test the CRC. When the CRC is open, Send a zero command until the CRC closes (The CRC will quickly close.)
- 2) When the CRC closes, remove the zero command.
- 3) When CRC opens again, send a span command until the CRC closes. (The CRC will quickly close.)
- 4) When the CRC closes, remove the span command.

When CRC opens again, zero and span are done, and the sample is being analyzed.

Note: The remote probe connections (paragraph 3.3.9) provides signals to ensure that the zero and span gas valves will be controlled synchronously. If you have the –C Internal valve option—which includes additional zero and span gas inputs—the 3020P automatically regulates the zero, span and sample gas flow.

3.3.6 Range ID Relays

There are four dedicated RANGE ID CONTACT relays. The first three ranges are assigned to relays in ascending order—Low range is assigned to RANGE 1 ID, Medium range is assigned to RANGE 2 ID, and High range is assigned to RANGE 3 ID. RANGE 4 ID is reserved for the Air Cal Range (25%).

3.3.7 Network I/O

A serial digital input/output for local network protocol. At this printing, this port is not yet functional. It is to be used in future versions of the instrument.

3.3.8 RS-232 Port

The digital signal output is a standard RS-232 serial communications port used to connect the analyzer to a computer, terminal, or other digital device. The pinouts are listed in Table 3-3.

Table 3-3: RS-232 Signals

RS-232 Sig	RS-232 Pin	Purpose
DCD	1	Data Carrier Detect
RD	2	Received Data
TD	3	Transmitted Data
DTR	4	Data Terminal Ready
COM	5	Common
DSR	6	Data Set Ready
RTS	7	Request to Send
CTS	8	Clear to Send
RI	9	Ring Indicator

The data sent is status information, in digital form, updated every two seconds. Status is reported in the following order:

- The concentration in percent

- The range in use (HI, MED, LO)
- The span of the range (0-100 %, etc)
- Which alarms—if any—are disabled (AL-x DISABLED)
- Which alarms—if any—are tripped (AL-x ON).

Each status output is followed by a carriage return and line feed.

Four input functions using RS-232 have been implemented to date. They are described in Table 3-4.

Table 3-4: Commands via RS-232 Input

Command	Description
as <enter>	Immediately starts an autospan.
az <enter>	Immediately starts an autozero.
co <enter>	Reports “Raw Cell Output” (current output of the sensor itself) in μA . For example— Raw Cell Output: 99 μA
st <enter>	Toggling input. Stops/Starts any status message output from the RS-232, until st <enter> is sent again.

The RS-232 protocol allows some flexibility in its implementation. Table 3-5 lists certain RS-232 values that are required by the 3020P implementation.

Table 3-5: Required RS-232 Options

Parameter	Setting
Baud	2400
Byte	8 bits
Parity	none
Stop Bits	1
Message Interval	2 seconds

3.3.9 Remote Sensor and Solenoid Valves

The 3020P is a single-chassis instrument, which has its own sensor and, in the -C option, its own gas-control solenoid valves. The REMOTE SENSOR connector is not used, and the SOLENOID RETURN connectors are used (without the -C option) to synchronize external gas control valves. See Figure 3-7.

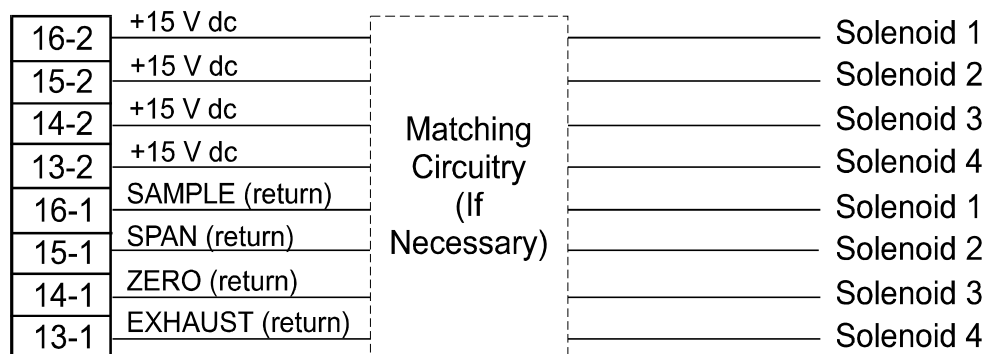

Figure 3-7: Remote Solenoid Return Connector Pinouts

The voltage from these outputs is nominally 0 V for the OFF and 15 V dc for the ON conditions. The maximum combined current that can be pulled from these output lines is 100 mA. (If two lines are ON at the same time, each must be limited to 50 mA, etc.) If more current and/or a different voltage is required, use a relay, power amplifier, or other matching circuitry to provide the actual driving current.

In addition, each individual line has a series FET with a nominal ON resistance of 5 ohms (9 ohms worst case). This could limit the obtainable voltage, depending on the load impedance applied. See Figure 3-8.

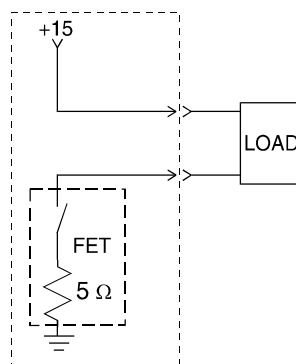

Figure 3-8: FET Series Resistance

3.4 Installing the Micro-Fuel Cell

The Micro-Fuel Cell is not installed in the cell block when the instrument is shipped. It must be installed before the analyzer is placed in service.

Once it is expended, the Micro-Fuel Cell will need to be replaced. The cell could also require replacement if the instrument has been idle for too long.

When the micro-Fuel Cell needs to be installed or replaced, follow the procedures in chapter 5, *Maintenance*, for removing and installing cells.

3.5 Gas Connections

Before using this instrument, it should be determined if the unit will be used for pressurized service or vacuum service and low pressure applications. Inspect the restrictor kit that came with the unit. The kit consist of two restrictors and a union for 1/4" diameter tubing. Notice that the two 1-3/4" long, 1/4" diameter tubing are restrictors. It has an open end and a closed end with a small circular orifice. The restrictor **without** the blue sticker is for low pressure and vacuum service. For high pressure (5 to 50 psig) applications, use the restrictor that has a blue sticker on the body.

For pressurized service (> 5psig) , use the restrictor **with** the blue dot and union from the restrictor kit and attach it to the Sample In port. The small circular orifice should face away from the back of the unit (against the direction of gas flow).

For positive pressures less than 5 psig use the low-pressure restrictor **without** the blue dot in the **Sample-in** line.

For vacuum service (5-10 in Hg), use the restrictor **without** the blue dot sticker and union but attach it to the **Exhaust Out** port. The small circular orifice should face toward the back of the unit (against the direction of gas flow).

Remove the blue sticker from the restrictor before using.

WARNING: *Operating the unit without restrictors can cause damage to the micro-fuel cell.*

Figure 3-9 is an illustration of the Gas Connector Panel. Optional gas connections are shown in shaded blocks.

The unit is manufactured with 1/4 inch tube fittings only. Adapters must be used for metric tubing. (At least 6 mm is recommended.)

For a safe connection:

1. Insert the tube into the tube fitting, and finger-tighten the nut until the tubing cannot be rotated freely, by hand, in the fitting. (This may require an additional 1/8 turn beyond finger-tight.)
2. Hold the fitting body steady with a backup wrench, and with another wrench rotate the nut another 1-1/4 turns.

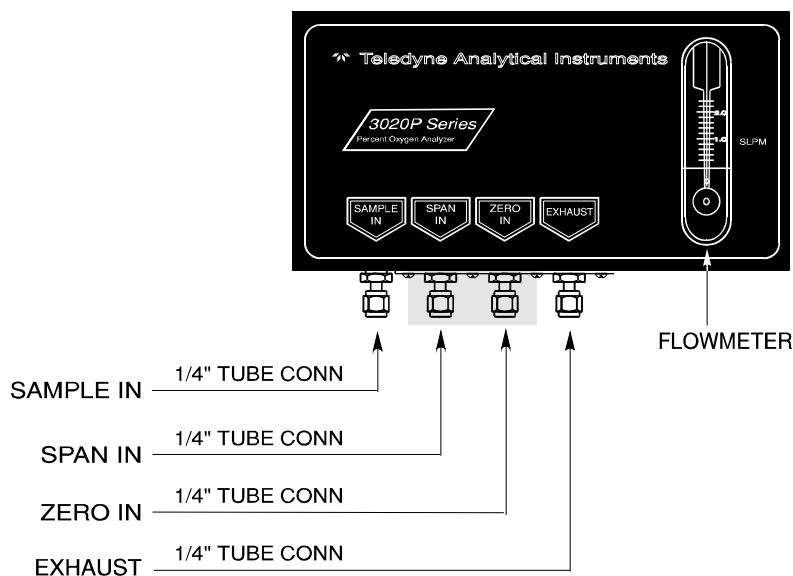

Figure 3-9: Gas Connector Panel

SAMPLE IN: In the standard model, gas connections are made at the SAMPLE IN and EXHAUST OUT connections. Calibration gases must be Tee'd into the Sample inlet with appropriate valves.

The gas pressure in should be reasonably regulated. Pressures between 3 and 40 psig are acceptable as long as the pressure, once established, will keep the front panel flowmeter reading in an acceptable range (0.1 to 2.4 SLPM). Exact figures will depend on your process.

If greater flow is required for improved response time, install a bypass in the sampling system upstream of the analyzer input.

Note: If the unit is for vacuum service, the above numbers apply instead to the vacuum at the EXHAUST OUT connector, described below, with minus signs before the pressure readings.

ZERO IN and SPAN IN: These are additional ports, included on models with the -C option, for inputting span gas and zero gas. There are electrically operated valves inside for automatic switching between sample and calibration gases. These valves are completely under control of the 3020P Electronics. They can be externally controlled only indirectly through the Remote Cal Inputs, described below.

Pressure, flow, and safety considerations are the same as prescribed for the SAMPLE IN inlet, above.

EXHAUST OUT: Exhaust connections must be consistent with the hazard level of the constituent gases. Check Local, State, and Federal laws, and ensure that the exhaust stream vents to an appropriately controlled area if required.

Note: If the unit is for vacuum service, see *Sample In*, above, for gas pressure/flow considerations.

3.6 Testing the System

Before plugging the instrument into the power source:

- Check the integrity and accuracy of the gas connections. Make sure there are no leaks.
- Check the integrity and accuracy of the electrical connections. Make sure there are no exposed conductors
- Check that sample pressure is between 3 and 40 psig, according to the requirements of your process.
- Check that the voltage selector switch on the Electrical Connector Panel is in the appropriate position for your power source.

Power up the system, and test it by performing the following operations:

1. Repeat the Self-Diagnostic Test as described in chapter 4, section 4.3.5.

Operation

4.1 Introduction

Once the analyzer has been installed, it can be configured for your application. To do this you will:

- Establish and start an automatic calibration cycle, if desired. (Electrically operated valves required.)
- Define the three user selectable analysis ranges. Then choose autoranging or select a fixed range of analysis, as required.
- Calibrate the instrument.
- Set alarm setpoints, and modes of alarm operation (latching, failsafe, etc).
- Establish a security password, if desired, requiring Operator to log in.

Before you configure your 3020P these default values are in effect:

Ranges: LO = 0-1 %, MED = 0-5 %, HI = 0-10 %.

Auto Ranging: ON

Alarm Relays: Defeated, 10 %, HI, Not failsafe, Not latching.

Zero: Auto, every 0 days at 0 hours.

Span: Auto, at 20.9 %, every 0 days at 0 hours.

Password: T E T A I

4.2 Using the Controls

To get the proper response from these controls, turn the control toward the desired action (ESCAPE or ENTER—DOWN or UP), and then release it. Turn-and-release once for each action. For example, turn-and-release twice toward UP to move the VFD screen two selections upwards on the list of options (menu).

The item that is between arrows on the screen is the item that is currently selectable by choosing ENTER (turn-and-release toward ENTER with the ESCAPE/ENTER control).

In these instructions, to ENTER means to turn-and-release toward ENTER, and To ESCAPE means to turn-and-release towards ESCAPE. To scroll UP (or scroll DOWN) means to turn-and-release toward UP (or DOWN) as many times as necessary to reach the required menu item.

4.2.1 Mode/Function Selection

When the analyzer is first powered up, and has completed its initialization and self diagnostics, ESCAPE toggles the instrument between the ANALYZE screen (*Analysis Mode*) and the MAIN MENU screen (*Setup Mode*). The ANALYZE screen is the only screen of the *Analysis Mode*.

The MAIN MENU screen is the top level in a series of screens used in the *Setup Mode* to configure the analyzer for the specific application. The DOWN/UP commands scroll through the options displayed on the VFD screen. The selectable option appears between arrows. When you reach the desired option by scrolling, ENTER the selection as described below.

ESCAPE takes you back up the hierarchy of screens until you reach the MAIN MENU again. ESCAPING any further just toggles between the MAIN MENU and the ANALYZE screen.

4.2.1.1 Analysis Mode

This is the normal operating mode. The analyzer monitors the oxygen content of the sample, displays the percent of oxygen, and warns of any alarm conditions. Either control switches you to *Setup Mode*. *Setup Mode* switches back to *Analyze Mode* if no controls are used for more than five seconds.

4.2.1.2 Setup Mode

The MAIN MENU consists of 12 functions you can use to customize and check the operation of the analyzer. Figure 4-1 shows the functions available with the 3020P. They are listed here with brief descriptions:

- 1 AUTO-CAL: Used to define and/or start an automatic calibration sequence.
- 2 PWD: Used to establish password protection or change the existing password.
- 3 LOGOUT: Logging out prevents unauthorized tampering with the analyzer settings.

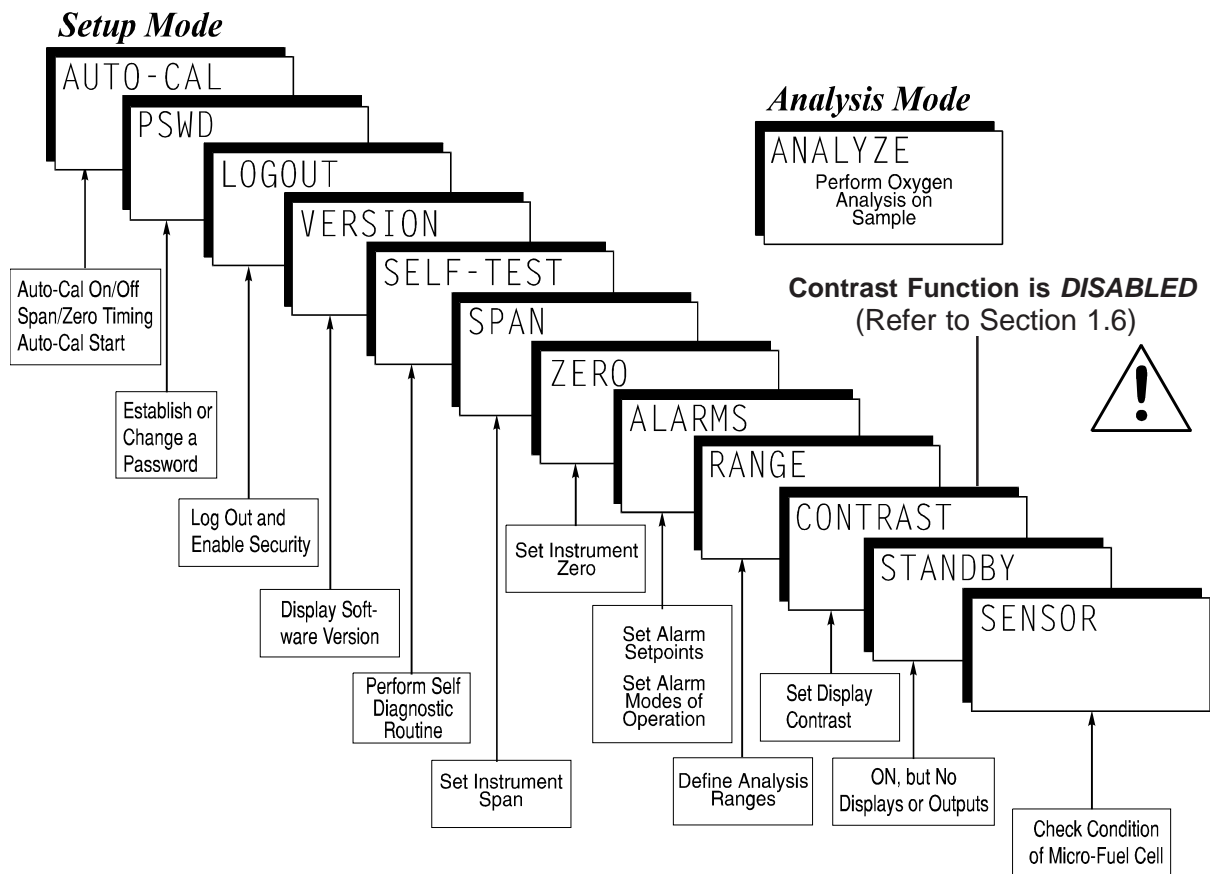

Figure 4-1: Modes and Functions

- 4 **VERSION:** Displays Manufacturer, Model, and Software version of the instrument.
- 5 **SELF-TEST:** The instrument performs a self-diagnostic routine to check the integrity of the power supply, output boards and amplifiers.
- 6 **SPAN:** Set up and/or start a span calibration.
- 7 **ZERO:** start a zero calibration.
- 8 **ALARMS:** Used to set the alarm setpoints and determine whether each alarm will be active or defeated, HI or LO acting, latching or not, and failsafe or not.
- 9 **RANGE:** Used to set up three analysis ranges that can be switched automatically with auto-ranging or used as individual fixed ranges.

- 10 **STANDBY**: Remove power to outputs and displays, but maintain power to internal circuitry.
- 11 **SENSOR**: Check the condition of the Micro-Fuel Cell sensor to determine whether it should be replaced.

Any function can be selected at any time. Just scroll through the MAIN MENU with the DOWN/UP control to the appropriate function, and ENTER it. The analyzer will immediately start that function, unless password restrictions have been assigned. (Password assignment is explained further on.)

All of these functions are described in greater detail in the procedures starting in section 4.3. The VFD screen texts used to illustrate the procedures are reproduced in a Monospaced type style.

4.2.2 Data Entry

4.2.2.1 ENTER

When the selected option is a function on the Main Menu screen, the function name appears between the arrows on the screen. You activate the function by turning the ESCAPE/ENTER control to ENTER.

When the selected option is a **function or subfunction**, ENTER moves the display to the VFD screen for that function or subfunction.

When the selected option is a **modifiable item**, the DOWN/UP control can be used to increment or decrement that modifiable item to the value or action you want. Then you ENTER the item, which also puts you into the next field to continue programming.

When the last field is entered, ENTER takes you to the next screen in the process, or if the process is completed, ENTER takes you back to the ANALYZE screen.

4.2.2.2 ESCAPE

A turn-and-release toward ESCAPE moves the blinking to the next field on the left. When you are on the leftmost field, another ESCAPE takes you back to the previous screen.

If you do not wish to continue a function, you can abort the session by escaping to the leftmost field, and then issuing another ESCAPE. Escaping a function takes the analyzer back to the previous screen, or to the ANALYZE Function, depending on the function escaped.

4.3 The AUTO-CAL Function

When proper automatic valving is connected (see chapter 3, *installation*), the Analyzer can cycle itself through a sequence of steps that automatically zero and span the instrument.

Note: If you require highly accurate timing of your AUTO-CAL, use external AUTO-CAL control where possible. The internal clock in the Model 3020P is accurate to 2-3 %. Accordingly, internally scheduled calibrations can vary 2-3 % per day.

To setup an AUTO-CAL cycle:

Scroll to AUTO-CAL, and ENTER. A new screen for Span/Zero set appears.

```
Span OFF Nxt: 0d 0h
Zero OFF Nxt: 0d 0h
```

If SPAN (or ZERO) is not flashing, scroll with DOWN/UP control to SPAN (or ZERO), then ENTER. (*You won't be able to set OFF to ON if a zero interval is entered.*) A Span Every ... (or Zero Every ...) screen appears.

```
Span Every 0 d
Start 0 h from now
```

Use DOWN/UP control to set an interval value, and ENTER. Then use DOWN/UP to set a start-time value, and ENTER.

```
Span OFF Nxt: 0d 0h
Zero OFF Nxt: 0d 0h
```

When the Span/Zero values screen appears, use the scroll DOWN to blink the OFF/ON field of the SPAN (or ZERO) function. Use DOWN/UP to set the OFF/ON field to ON. *You can now turn these fields ON because there is a nonzero span interval defined.*

4.4 The PWD (Password) Function

Security can be established by choosing a 5 digit password from the standard ASCII character set. If you decide NOT to employ password security, use the default password TETAI. This password will be displayed automatically by the microprocessor. The operator just ENTERs it to be allowed total access to the instrument's features.

Once a unique password is assigned and activated, the operator MUST enter the UNIQUE password to gain access to any of the set-up functions (except to enter the **password**). However, the instrument will continue to

analyze sample gas and report on alarm conditions without entering the password.

- **Only one password can be defined.**
- After a password is assigned, the operator must **log out** to activate it. Until then, anyone can continue to operate the instrument without entering the new password.
- To defeat the security after a unique password is activated, the password must be changed back to TETAI.

NOTE: If you use password security, it is advisable to keep a copy of the password in a separate, safe location.

4.4.1 Entering the Password

To install a new password or change a previously installed password, you must key in and enter the old password first. If the default password is in effect, issuing the ENTER command will enter the default TETAI password for you.

Scroll to PWD, and ENTER to select the password function. Either the TETAI default password or AAAAA place-holder password for an existing password will appear on screen depending on whether or not a password has been previously installed.

```

T E T A I
Enter PWD

  or

A A A A A
Enter PWD

```

The screen prompts you to enter the current password. If you are not using password protection, ENTER to accept TETAI as the default password. If a password has been previously installed, enter the password using ENTER to scroll through the letters, and the DOWN/UP keys to change the letters to the proper password. The last ENTER enters the password.

If the password is accepted, the screen will indicate that the password restrictions have been removed and you have clearance to proceed.

```

PWD  Restrictions
      Removed

```

In a few seconds, if you do not ESCAPE, you will be given the opportunity to change this password or keep it and go on.

Change Password?
 <ENT>=Yes <ESC>=No

ESCAPE to move on, or proceed as in *Changing the Password*, below.

4.4.2 Installing or Changing the Password

If you want to change the existing password: Proceed as above in *Entering the Password*, until you are given the opportunity to change the password:

Change Password?
 <ENT>=Yes <ESC>=No

ENTER to change the password (to change either the default TETAI or the previously assigned password), or ESCAPE to keep the existing password and move on.

If you choose ENTER to change the password, the password assignment screen appears.

T E T A I
 <ENT> To Proceed

or

A A A A A
 <ENT> To Proceed

Enter the password using ENTER to scroll through the existing password letters, and DOWN/UP to change the letters to the new password. The full set of 94 characters available for password use are shown in the table below.

Characters Available for Password Definition:

A	B	C	D	E	F	G	H	I	J
K	L	M	N	O	P	Q	R	S	T
U	V	W	X	Y	Z	[¥]	^
_	`	a	b	c	d	e	f	g	h
i	j	k	l	m	n	o	p	q	r
s	t	u	v	w	x	y	z	{	
}	→	!	"	#	\$	%	&	'	(
)	*	+	'	-	.	/	0	1	2
3	4	5	6	7	8	9	:	;	<
=	>	?	@						

When you have finished typing the new password, the last ENTER enters it. A verification screen appears. The screen will prompt you to retype your password for verification.

```

A A A A A
Retype PWD To Verify

```

Wait a moment for the entry (<ENT>) screen. You will be given clearance to proceed.

```

A A A A A
<ENT> TO Proceed

```

ENTER the letters of your new password. Your password will be stored in the microprocessor and the system will immediately switch to the ANALYZE screen, and you now have access to all instrument functions.

If all alarms are defeated, the ANALYZE screen appears as:

```

0.0    %  Anlz
Range: 0 — 100

```

If an alarm is tripped, the second line will change to show which alarm it is:

```

0.0    %  Anlz
AL — 1

```

NOTE: If you log off the system using the LOGOUT function in the MAIN MENU, you will now be required to re-enter the password to gain access to any of the functions except password (PWD).

4.5 The LOGOUT Function

By entering LOGOUT, you effectively log off the instrument, leaving the system protected against tampering until the password is reentered. To log out, scroll to place the LOGOUT function between the arrows, and ENTER to log out. The screen will display the message:

```

Protected Until
Password Reentered

```

4.6 The VERSION Screen

Scroll through the MAIN MENU to VERSION, and ENTER. The screen displays the manufacturer, model, and software version information.

4.7 The SELF-TEST Function

The Model 3020P has a built-in self-testing diagnostic routine. Preprogrammed signals are sent through the power supply, output board and sensor circuit. The return signal is analyzed, and at the end of the test the status of each function is displayed on the screen, either as OK or as a number between 1 and 3. (See *System Self Diagnostic Test* in chapter 5 for number code.)

The self diagnostics are run automatically by the analyzer whenever the instrument is turned on, but the test can also be run by the operator at will. To initiate SELF-TEST during operation:

Use the DOWN/UP control to scroll through the MAIN MENU to SELF-TEST. The screen will follow the running of the diagnostic.

```
RUNNING DIAGNOSTIC
Testing Preamp — 83
```

During preamp testing there is a countdown in the lower right corner of the screen. When the testing is complete, the results are displayed.

```
Power: OK   Analog: OK
Preamp: 3
```

The module is functioning properly if it is followed by OK. A number indicates a problem in a specific area of the instrument. Refer to Chapter 5 *Maintenance* for number-code information. The results screen alternates for a time with:

```
Press Any Key
To Continue...
```

Then the analyzer returns to the ANALYZE screen.

4.8 The SPAN Functions

The analyzer is calibrated using span gas.

NOTE: *Zero is not necessary for Percent (%) level measurements.*

Additional information on Zero functions is provided in the Appendix A-5 of this manual.

Although the instrument can be spanned using air, a span gas with a known oxygen concentration in the range of 70–90% of full scale of the range of interest is recommended for best results. In addition, since the oxygen concentration in air is 20.9 %, the cell can take longer than usual to recover if the instrument is used in the 0-1 % range immediately following calibration in air.

Connect the calibration gases to the analyzer according to the instructions given in section 3.5, *Gas Connections*, observing all the prescribed precautions.

Shut off the gas pressure before connecting it to the analyzer, and be sure to limit the pressure to 40 psig or less when turning it back on.



Readjust the gas pressure into the analyzer until the flowrate (as read on the analyzer's SLPM flowmeter) settles between 0.5 and 2.4 SLPM (approximately 1-5 scfh).

If you are using password protection, you will need to enter your password to gain access to either of these functions. Follow the instructions in section 4.4 to enter your password. Once you have gained clearance to proceed, you can ENTER the ZERO or SPAN function.

4.8.1. Cell Failure

When the sensor in the 3020P begins to fail, the analyzer will usually require more and more frequent calibration. If the 3020P analysis readings drift downward uncharacteristically, try recalibration. If recalibration raises the readings temporarily only, suspect the cell.

Before replacing the cell:

- a. Check for leaks downstream from the cell, where oxygen may be leaking into the system.
- b. Check your span gas to make sure it is within specifications.
- c. If there are no leaks and the span gas is OK, check the output of the cell itself by scrolling the MAIN MENU TO SENSOR.

When you ENTER the function, the sensor report screen appears.

RAW CELL OUTPUT

μA

The “good” reading depends on the class of cell your analyzer is using as well as the **known** oxygen concentration.

Although the B-1 cell is standard in the 3020P, **check *Specific Model Information in the Front Matter in this manual for the class of cell you purchased.*** Then check *Cell Replacement* in chapter 5 *Maintenance*, and do the prescribed calculations. If a weak cell is indicated, replace the cell as described in chapter 5.

4.8.2 Span Cal

SPAN is used to span calibrate the analyzer. Span calibration can be performed using the **automatic** mode, where an internal algorithm compares consecutive readings from the sensor to determine when the output matches the span gas concentration. Span calibration can also be performed in **manual** mode, where the operator determines when the span concentration reading is acceptable and manually exits the function.

4.8.2.1 Auto Mode Spanning

Scroll to SPAN, and ENTER the SPAN function. The screen that appears allows you to select whether the span calibration is to be performed automatically or manually. Use the DOWN/UP control to toggle between AUTO and MAN span settling. Stop when AUTO appears on the display.

```
Span: Settling: AUTO
<ENT> For Next
```

Use ENTER to move to the next screen.

```
Span Val: 20.90
<ENT>Span <UP>Mod #
```

Use DOWN/UP to start changing the oxygen-concentration. Use ESCAPE/ENTER to blink the digit you are going to modify. Use DOWN/UP again to change the value of the selected digit. When you have finished typing in the concentration of the span gas you are using, repeatedly select ENTER until the rightmost digit is reached, then, the next ENTER will exit the Span Val screen. One more ENTER will enter the new span value, bring up the next screen, and start the span calibration.

```
#### % Span
Slope=#### ppm/s
```

The beginning span value is shown in the upper left corner of the display. As the span reading settles, the screen displays and updates information on Slope. Spanning automatically ends when the span output corresponds, within tolerance, to the value of the span gas concentration. Then the instrument automatically returns to the ANALYZE mode.

4.8.2.2 Manual Mode Spanning

ENTER SPAN from the MAIN MENU to start the SPAN function. The screen that appears allows you to select whether the span calibration is to be performed automatically or manually.

```
Span: Settling:MAN
<ENT> For Next
```

Use DOWN/UP to toggle between AUTO and MAN span setting. Stop when MAN appears on the display. Use ENTER to move to the next screen.

```
Span Val: 20.90
<ENT>Span <UP>Mod #
```

Use UP to permit modification (Mod #) of span value.

Use ESCAPE/ENTER to choose the digit, and use DOWN/UP to choose the value of the digit.

When you have finished typing in the concentration of the span gas you are using, repeatedly select ENTER until the rightmost digit is reached, then, the next ENTER will exit the Span Val field. One more ENTER will enter the new span value, bring up the next screen, and start the span calibration.

Once the span has begun, the microprocessor samples the output at a predetermined rate. It calculates the difference between successive samplings and displays this difference as Slope on the screen. It takes several seconds for the first Slope value to display. Slope indicates rate of change of the Span reading. It is a sensitive indicator of stability.

```
####    % Span
Slope=####    ppm/s
```

When the Span value displayed on the screen is sufficiently stable, ENTER it. (Generally, when the Span reading changes by 1 % or less of the full scale of the range being calibrated for a period of ten minutes it is sufficiently stable.) Once you ENTER it, the Span reading changes to the correct value. The instrument then **automatically** enters the ANALYZE function.

4.9 The ALARMS Function

The Model 3020P is equipped with 2 fully adjustable concentration alarms and a system failure alarm. Each alarm has a relay with a set of form "C" contacts rated for 3 amperes resistive load at 250 V ac. See Figure in Chapter 3, *Installation* and/or the Interconnection Diagram included at the back of this manual for relay terminal connections.

The system failure alarm has a fixed configuration described in chapter 3 *Installation*.

The concentration alarms can be configured from the front panel as either *high* or *low* alarms by the operator. The alarm modes can be set as *latching* or *non-latching*, and either *failsafe* or *non-failsafe*, or, they can be *defeated* altogether. The setpoints for the alarms are also established using this function.

Decide how your alarms should be configured. The choice will depend upon your process. Consider the following four points:

1. Which if any of the alarms are to be high alarms, and which if any are to be low alarms?

Setting an alarm as HIGH triggers the alarm when the oxygen concentration rises above the setpoint. Setting an alarm as LOW triggers the alarm when the oxygen concentration falls below the setpoint.

Decide whether you want the alarms to be set as:

- Both high (high and high-high) alarms, or
- One high and one low alarm, or
- Both low (low and low-low) alarms.

2. Are either or both of the alarms to be configured as failsafe?

In failsafe mode, the alarm relay de-energizes in an alarm condition. For non-failsafe operation, the relay is energized in an alarm condition. You can set either or both of the concentration alarms to operate in failsafe or non-failsafe mode.

3. Are either of the alarms to be latching?

In latching mode, once the alarm or alarms trigger, they will remain in the alarm mode even if process conditions revert back to non-alarm conditions. This mode requires an alarm to be recognized before it can be reset. In the non-latching mode, the alarm status will terminate when process conditions revert to non-alarm conditions.

4. Are either of the alarms to be defeated?

The defeat alarm mode is incorporated into the alarm circuit so that maintenance can be performed under conditions which would normally activate the alarms.

The defeat function can also be used to reset a latched alarm. (See procedures, below.)

If you are using password protection, you will need to enter your password to access the alarm functions. Follow the instructions in section 4.4 to enter your password. Once you have clearance to proceed, ENTER the ALARM function.

AL-1 AL-2
Choose Alarm

Use the DOWN/UP control to blink your choice of alarm, AL-1 or AL-2. Then ENTER to move to the next screen.

AL-1 1.00 % HI
Dft-N Fs-N Ltch-N

Five parameters can be changed on this screen.

- Value of the alarm setpoint: AL-1 ##### % (oxygen)
- Out-of-range direction: HI or LO
- Defeated? (Yes/No): Dft-Y/N
- Failsafe? (Yes/No): Fs-Y/N
- Latching? (Yes/No): Ltch-Y/N.
- To define the setpoint, use ENTER to blink AL-1 #####, if not already blinking. Then use the DOWN/UP control to change the number. Holding the control on the DOWN or UP position, while the number changes, speeds up the incrementing or decrementing. (Remember, the setpoint units are always % O₂.)
- To set the other parameters use ENTER to blink the desired parameter. Then use DOWN/UP to change the parameter.
- Once the parameters for the alarm have been set, ENTER the ALARM function again, and repeat this procedure for next alarm.
- To reset a latched alarm:

Go to Dft- and then assert either DOWN two times or UP two times. (Toggle it to Y and then back to N.)

-OR-

Go to Ltch- and then assert either DOWN two times or UP two times. (Toggle it to N and back to Y.)

Note: In this screen, ENTER moves you through the fields and ESCAPE takes you back to the previous screen.

4.10 The RANGE Function

The RANGE function allows the operator to program up to three concentration ranges to correlate with the DC analog outputs. If no ranges are defined by the user, the instrument defaults to:

Low = 0-1 %
Med = 0-5 %
High = 0-10 %.

The Model 3020P is set at the factory to default to autoranging. In this mode, the microprocessor automatically responds to concentration changes by switching ranges for optimum readout sensitivity. If the current range limits are exceeded, the instrument will automatically shift to the next higher

range. If the sample concentration falls below the full scale of the next lower range, the instrument will switch to that range. A corresponding shift in the DC percent-of-range output, and in the range ID outputs, will be noticed.

The autoranging feature can be overridden so that analog output stays on a fixed range regardless of the oxygen concentration detected. If the concentration exceeds the upper limit of the range, the DC output will saturate at 1 V dc (20 mA at the optional current output).

However, the digital readout and the RS-232 output of the concentration are unaffected by the fixed range. They continue to read accurately with full precision. See *Front Panel* description in Chapter 1.

The automatic air calibration range is always 0-25 % and is not programmable.

4.10.1 Setting the Analog Output Ranges

To set the ranges, ENTER the RANGE function mode by selecting RANGE from the MAIN MENU. The RANGE screen appears.

```
L—1.00   M—5.00
H—10.00  Mode—AUTO
```

Use the DOWN/UP control to the range to be set: low (L), medium (M), or high (H).

Use the DOWN/UP control to enter the upper value of the range (all ranges begin at 0 %). Repeat for each range you want to set. ENTER to accept the values and return to the *Analysis Mode*. (See note below.)

Note: The ranges must be increasing from low to high, for example, if range 1 is set as 0–10 % and range 2 is set as 0–100 %, range 3 cannot be set as 0–25 % since it is lower than range 2.

4.10.2 Automatic Ranging

After defining your analysis ranges, set Mode– to AUTO, if not already there. ESCAPE to re-enter the ANALYZE screen using the fixed range.

4.10.3 Fixed Range Analysis

The autoranging mode of the instrument can be overridden, forcing the analyzer DC outputs to stay in a single predetermined range.

To switch from autoranging to fixed range analysis, ENTER the RANGE function by selecting RANGE from the MAIN MENU.

Use the DOWN/UP control to move AUTO between the arrows.

Use the DOWN/UP control to switch from AUTO to FX/LO, FX/MED, or FX/HI to set the instrument on the desired fixed range (low, medium, or high).

L—1.00 M—5.00
H—10.00 Mode—FX/LO

or

L—1.00 M—5.00
H—10.00 Mode—FX/MED

or

L—1.00 M—5.00
H—10.00 Mode—FX/HI

ESCAPE to re-enter the ANALYZE screen using the fixed range.

Note: When performing analysis on a fixed range, if the oxygen concentration rises above the upper limit, as established by the setup, for that particular range, the output saturates at 1 V dc (20 mA at optional mA dc output). However, the digital readout and the RS-232 output continue to read the true value of the oxygen concentration regardless of the analog output range.

4.11 The CONTRAST Function

Contrast Function is **DISABLED** 
(Refer to Section 1.6)

If you cannot read anything on the display after first powering up:

1. Observe LED readout.
 - a. If LED meter reads all **eights and dots**, go to step 3.
 - b. If LED meter displays anything else, go to step 2.
2. Disconnect power to the Analyzer and reconnect again. LED meter should now read all eights and dots.

4.12 The STANDBY Function

In STANDBY, the analyzer's internal circuits are powered, but there are no displays or outputs from the analyzer.

WARNING: *THE POWER CABLE MUST BE UNPLUGGED TO FULLY DISCONNECT POWER FROM THE INSTRUMENT. WHEN THE ACCESS DOOR IS OPEN AND THE POWER CABLE IS CONNECTED, EXTRA CARE IS REQUIRED TO AVOID CONTACT WITH LIVE ELECTRICAL CIRCUITS.*

CAUTION: *If you disconnect the primary power source from the analyzer, then on re-energizing, you will be required to choose to keep the configuration you previously programmed into your instrument in the Setup Mode by pressing the "Enter" key, or by pressing the "Escape" key to reset to factory defaults. Of you press neither key, the instrument will time out and take your previous configuration.*

4.13 The SENSOR Function

This function is described in *Cell Failure*, section 4.8.1.3.

4.14 The *Analysis Mode*

This is the normal operating mode of the analyzer. In this mode the analyzer is monitoring the sample, measuring and displaying the amount of oxygen, and reporting alarm conditions.

Normally, the Version, Self-Test, Sensor, Main Menu, and the Span and Zero (in auto-settling mode) functions automatically switch back to the *Analysis Mode* ANALYZE screen when they have completed their assigned operations. After four or five seconds in the MAIN MENU without any action by the operator, the analyzer automatically switches itself back to the ANALYZE screen. ESCAPE, asserted one or more times, depending on the starting point, also switches the analyzer back to the ANALYZE screen.

Maintenance

5.1 Routine Maintenance



Aside from normal cleaning and checking for leaks at the gas connections, routine maintenance is limited to replacing Micro-Fuel cells and fuses, and recalibration. For recalibration, see Section 4.4 *The Zero and Span Functions*.



WARNING: SEE WARNINGS ON TITLE PAGE OF THIS MANUAL.

5.2 Major Internal Components

All internal components are accessed by unbolting and swinging open the front cover, as described earlier. The major internal component locations are shown in Figure 3-1, the cell block is illustrated in Figure 3-2, and the fuse receptacle is shown in Figure 3-3

The 3020P contains the following major internal components:

- Micro-Fuel Cell
- Nylon cell block
- Customer Interface PCB (Power Supply on bottom surface)
- Preamp PCB (Contains Microprocessor)
- Front Panel PCB (Contains Displays)
 - 5 digit LED meter
 - 2 line, 20 character, alphanumeric, VFD display
- Solenoid Operated Gas Control Valves (–C option only).

See the drawings in the Drawings section in back of this manual for details.

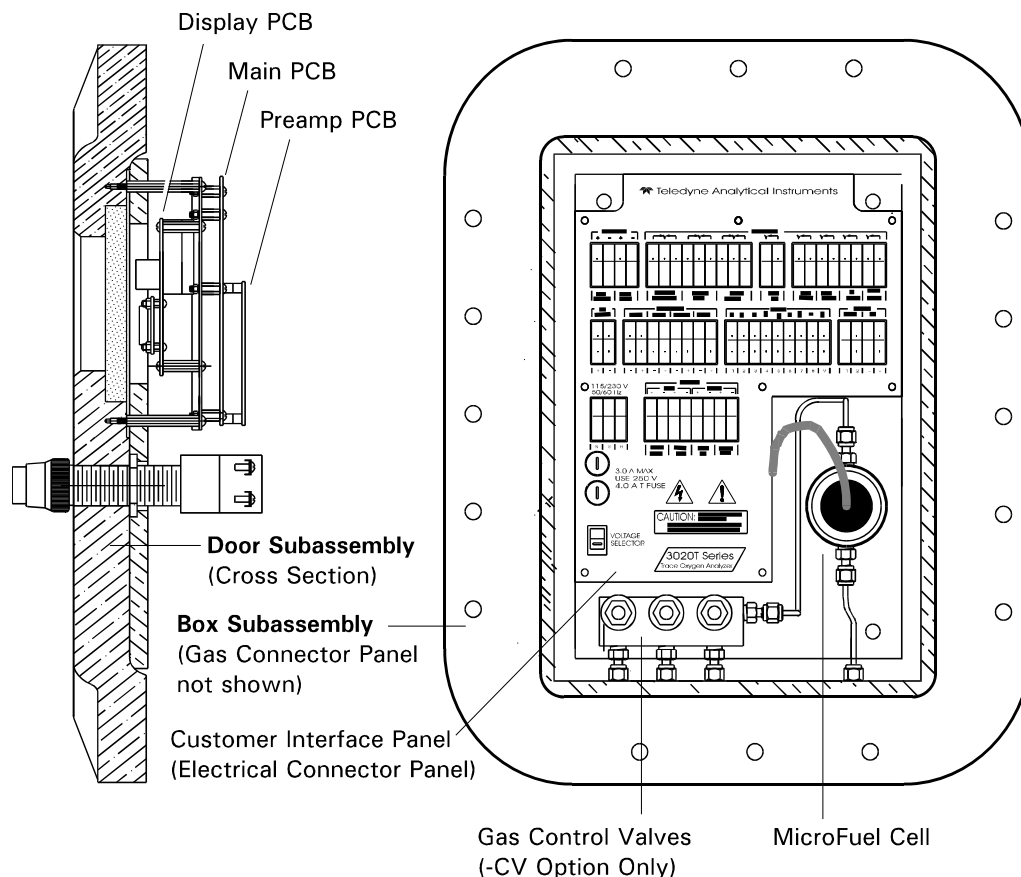

Figure 5-1: Major Internal Components

To swing open the cover panel, remove all screws.

5.3 Cell Replacement

The Micro-Fuel Cell is a sealed electrochemical transducer with no electrolyte to change or electrodes to clean. When the cell reaches the end of its useful life, it is replaced. The spent fuel cell should be discarded in accordance with to all applicable safety and environmental regulations. This section describes fuel cell care as well as when and how to replace it.

The Class B-1 Micro-Fuel Cell is used in the standard Model 3020P. If any other cell is supplied with your instrument, check the front of this manual for any addenda applying to your special model.

5.3.1 Storing and Handling Replacement Cells

To have a replacement cell available when it is needed, it is recommended that one spare cell be purchased 4-5 months after commissioning the 3020P, or shortly before the end of the cell's warranty period.

CAUTION: *Do not stockpile cells. The warranty period starts on the day of shipment.*

The spare cell should be carefully stored in an area that is not subject to large variations in ambient temperature (75 °F nominal) or to rough handling.

WARNING: THE SENSOR USED IN THE MODEL 3020P PERCENT OXYGEN ANALYZER USES ELECTROLYTES WHICH CONTAIN TOXIC SUBSTANCES, MAINLY LEAD AND POTASSIUM HYDROXIDE, THAT CAN BE HARMFUL IF TOUCHED, SWALLOWED, OR INHALED. AVOID CONTACT WITH ANY FLUID OR POWDER IN OR AROUND THE UNIT. WHAT MAY APPEAR TO BE PLAIN WATER COULD CONTAIN ONE OF THESE TOXIC SUBSTANCES. IN CASE OF EYE CONTACT, IMMEDIATELY FLUSH EYES WITH WATER FOR AT LEAST 15 MINUTES. CALL PHYSICIAN. (SEE APPENDIX, MATERIAL SAFETY DATA SHEET.)

5.3.2 When to Replace a Cell

When the sensor in the 3020P begins to fail, the analyzer will usually require more and more frequent calibration. If the 3020P analysis readings drift downward uncharacteristically, try recalibration. If recalibration raises the readings temporarily only, suspect the cell.

Before replacing the cell:

- a. Check for leaks downstream from the cell, where oxygen may be leaking into the system.
- b. Check your span gas to make sure it is within specifications.
- c. If there are no leaks and the span gas is OK, check the output of the cell itself by scrolling the MAIN MENU TO SENSOR.

When you ENTER the function, the sensor report screen appears.

RAW CELL OUTPUT

μA

The “good” reading depends on the class of cell your analyzer is using.

Although the B-1 cell is standard in the 3020P, **check *Specific Model Information in the Front Matter in this manual for the class of cell you purchased.*** Then check Table 5-1, the Cell Indices table below, and do the prescribed calculations. If the resulting value is below the Cell Output reading, replace the cell.

To find out if the cell is too weak:

1. Flow span gas through the analyzer, and allow time to purge.
2. With span gas flowing, read the raw output of the cell from the *System* function display.
3. Divide the raw output reading by the percent oxygen concentration of your span gas.

If the quotient is less than the Index value for the cell class you are using, replace the cell.

Table 5-1: Cell Indices

Cell Class	Index
A-3	1.818
A-5	1.818
B-1	4.545
B-3	3.716
B-5	1.244
B-7	1.515
C-3	2.488
C-5	0.606

5.3.3 Removing the Micro-Fuel Cell

The Micro-Fuel Cell is located inside the nylon cell block inside the unit (see Figure 5-1). To remove an existing cell:

1. Remove power to the instrument by unplugging the power cord at the power source.
2. Open the front panel door by unbolting it and swinging it open on its hinges.
3. Leave the cell block installed. Pull up on the probe, with a slight rocking motion, to release it from the probe receptacle.

4. Do not remove the O-rings unless they are worn and no longer hold the probe tightly. (If worn, replace them.)

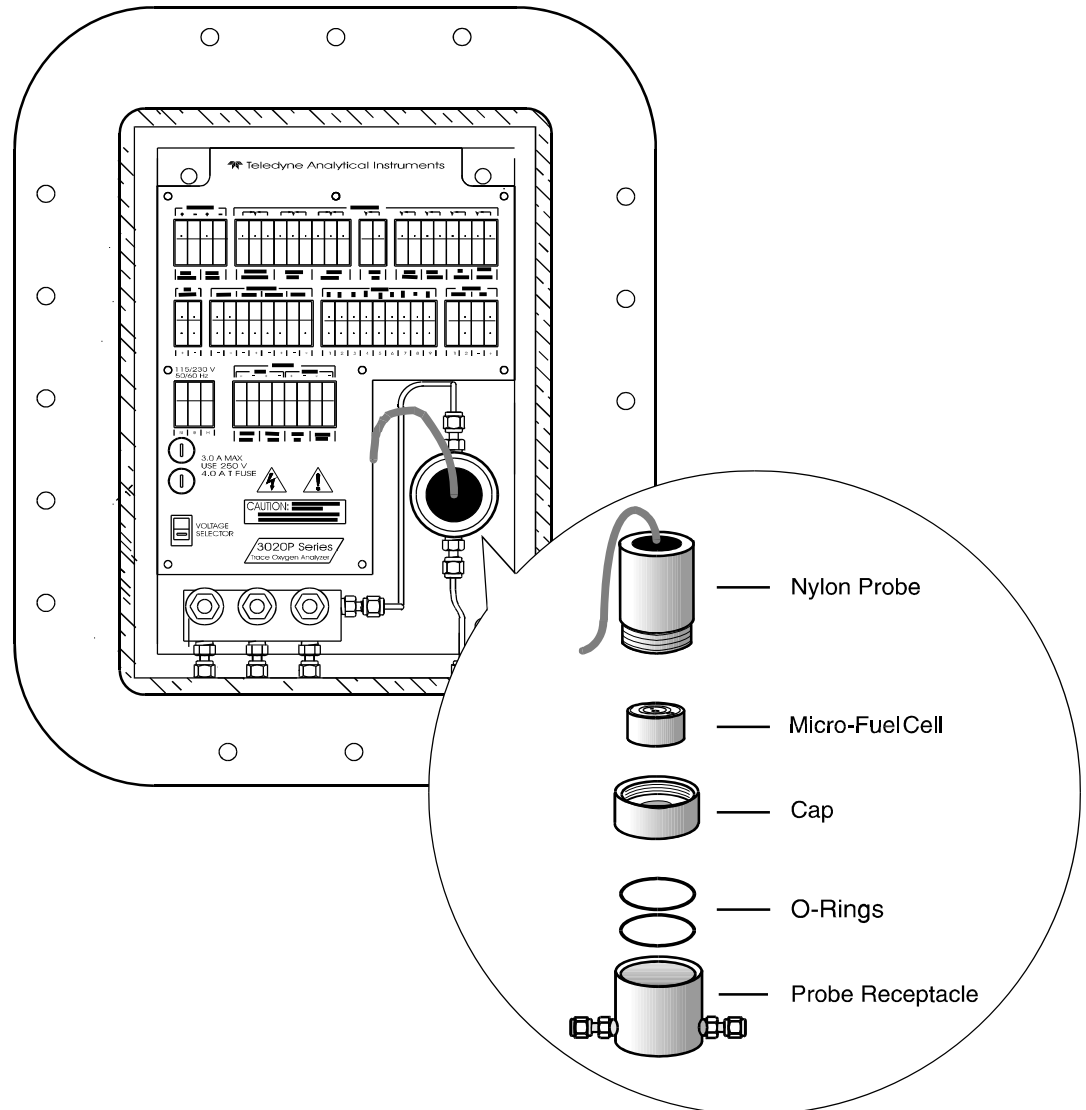

Figure 5-2: Exploded View of Cell Block and Micro-Fuel Cell

5. When it is free, unscrew the cap from the nylon probe. **Hold the probe vertically to prevent dropping the cell out of the probe.**
6. Remove the cell from the probe, and dispose of it in an environmentally safe manner.

5.3.4 Installing a New Micro-Fuel Cell

CAUTION: *Do not touch the sensing surface of the cell. It is covered with a delicate Teflon membrane that can leak when punctured. The sensor must be replaced if the membrane is damaged.*

Before installing a new cell, check the O-ring in the base of the cell holder. Replace if worn or damaged.

1. Place the Cell in the Probe with the sensing surface facing outward (toward the screen in the Cap).
2. Screw the Probe Cap onto the Probe until it stops.
3. With the O-rings in place, push the assembled Probe down into the Cell Holder—Cap Down—with a slight rocking motion until it is seated on the bottom of the holder. This forces the holder into position and forms a gas-tight seal.

5.3.5 Cell Warranty

The Class B-1 Micro-Fuel cell is standard in the Model 3020P. This cell is a long life cell and is warranted for 6 months from the date of shipment. The customer should purchase only one spare cell (per section 5.3.1). Do not attempt to stockpile spare cells.

If any cell other than the B-1 is supplied with your instrument, check *Specific Model Information* in the front of this manual for any special information applying to your cell.

Caution: *The B-1 cell is not designed for applications where CO₂ is a major component in the sample, however slight amounts will not adversely effect the cell performance.*

If a cell was working satisfactorily, but ceases to function before the warranty period expires, the customer will receive credit toward the purchase of a new cell.

If you have a warranty claim, you must return the cell in question to the factory for evaluation. If it is determined that failure is due to faulty workmanship or material, the cell will be replaced at no cost to you.

Note: **Evidence of damage due to tampering or mishandling will render the cell warranty null and void.**

5.4 Fuse Replacement

The 3020P requires two 5 x 20 mm, 4 A, T type (Slow Blow) fuses. The fuses are located inside the explosion proof housing on the Electrical Connector Panel, as shown in Figure 5-2. To replace a fuse:

1. Disconnect the Unit from its power source.
2. Place a small screwdriver in the notch in the fuse holder cap, push in, and rotate 1/4 turn. The cap will pop out a few millimeters. Pull out the fuse holder cap and fuse, as shown in Figure 5-3.

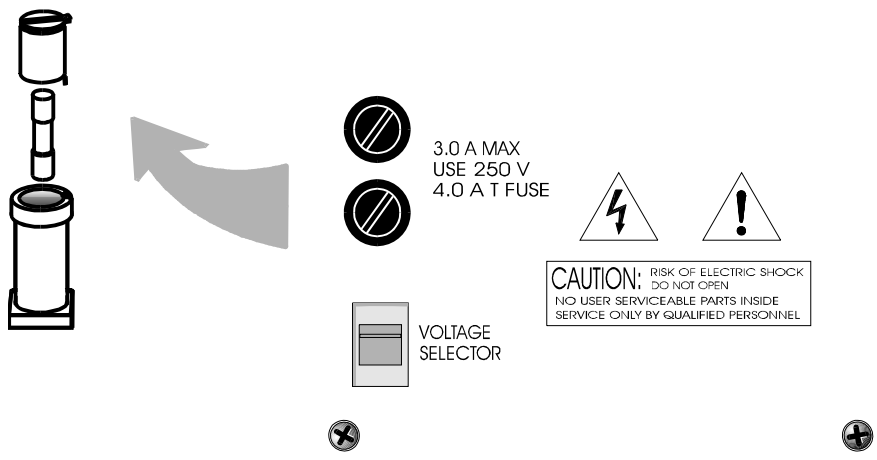

Figure 5-3: Removing Fuse Cap and Fuse from Holder

2. Replace fuse by reversing process in step 1.

5.5 System Self Diagnostic Test

Use the DOWN/UP control to scroll through the MAIN MENU to SELF-TEST. The screen will follow the running of the diagnostic.

RUNNING DIAGNOSTIC
Testing Preamp — 83

During preamp testing there is a countdown in the lower right corner of the screen. When the testing is complete, the results are displayed.

Power: OK Analog: OK
Preamp: 3

The module is functioning properly if it is followed by OK. A number indicates a problem in a specific area of the instrument. Refer to Table 5-1 for number-code information. The results screen alternates for a time with:

Press Any Key
To Continue...

The following failure codes apply:

Table 5-1: Self Test Failure Codes

Power

- 0 OK
- 1 5 V Failure
- 2 15 V Failure
- 3 Both Failed

Analog

- 0 OK
- 1 DAC A (0–1 V Concentration)
- 2 DAC B (0–1 V Range ID)
- 3 Both Failed

Preamp

- 0 OK
- 1 Zero too high
- 2 Amplifier output doesn't match test input
- 3 Both Failed

Appendix

A-1 Specifications

Packaging: Explosion-proof. Bulkhead mount.

Sensor: Class B-1 percent analysis Micro-Fuel Cell.

Cell Block: Nylon.

Ranges: Three user definable ranges from 0-1 % to 0-100 %, plus air calibration range of 0-25 %.

Autoranging with range ID output.

Sample System: Flow indicator visible from front of unit.

Positive pressure service.

Vacuum service (optional).

Auto Cal / Auto Zero. (Available with optional, electrically operated valves.)

Alarms: One system-failure alarm contact to detect power failure.

Two adjustable concentration threshold alarms with fully programmable setpoints.

Diagnostics: Start-up or on-demand self-testing function.

Displays: 2 line by 20 alphanumeric, VFD screen, and one 5 digit LED display.

Digital Interface: Full duplex RS-232 communications port.

Power: Universal power supply 115 or 230 V ac, at 50 or 60 Hz.

Operating Temperature: 0-50 °C

Accuracy: $\pm 2\%$ of full scale at constant temperature.
 $\pm 5\%$ of full scale over operating temperature range, on factory default analysis ranges, once thermal equilibrium has been achieved.

Analog outputs: 0-1 V dc percent-of-range
0-1 V dc range ID.

Optional:
4-20 mA dc percent-of-range
4-20 mA dc range ID.

Password Access: Can be user-configured for password protection.

A-2 Recommended 2-Year Spare Parts List

QTY.	PART NUMBER	DESCRIPTION
1	C62371B	Display PCB
1	D65295A	Customer Interface PCB
1	C62368-B	Percent Preamplifier Board
1*	C73870-C	Main PCB (Standard)
1*	C73870-A	Main PCB (4-20 mA option)
3	F1295	Fuse, 4A, 250V, 5x20 mm, T (Slow Blow)
2	O38	O-ring
1	C6689-B1	Micro-Fuel Cell (For options see **)

* Order -B or -C, not both.

** Check *Specific Model Information* in front matter of this manual for cell options.

Note: Orders for replacement parts should include the part number (if available) and the model and serial number of the instrument for which the parts are intended.

Orders should be sent to:

Teledyne Analytical Instruments
 16830 Chestnut Street
 City of Industry, CA 91748

Phone (626) 934-1500, Fax (626) 961-2538

Web: www.teledyne-ai.com

or your local representative.

A-3 Drawing List

- D66050 Final Assembly Drawing (Stainless Steel Cell Block)
- D66066 Final Assembly Drawing (Nylon Cell Block)
- D65909 Outline Drawing
- D66067 Wiring Diagram

NOTE: The MSDS on this material is available upon request through the Teledyne Environmental, Health and Safety Coordinator. Contact at (626) 934-1592

A-4**3000 SERIES ANALYZERS
APPLICATION NOTES ON RESTRICTORS,
PRESSURES, AND FLOW RECOMMENDATIONS**

3000 series analyzers require reasonably regulated sample pressures. While the 3000 analyzers are not sensitive to variations of incoming pressure (provided they are properly vented to atmospheric pressure) The pressure must be maintained as to provide a useable flow rate through the analyzer. Any line attached to sample vent should be 1/4 or larger in diameter.

FLOW RATE RECOMMENDATIONS:

A usable flow rate for a 3000 series analyzer is one which can be measured on the flowmeter. This is basically .2 - 2.4 SLPM. The optimum flow rate is 1 SLPM (mid scale). Note: response time is dependent on flow rate, a low flow rate will result in slow response to O₂ changes in the sample stream. The span flow rate should be the approximately same as the sample flow rate.

CELL PRESSURE CONCERNS:

The sensors used in 3000 series analyzers are optimized to function at atmospheric pressure. At pressures other than atmospheric the diffusion rate of O₂ will be different than optimum value. Higher pressures will produce faster O₂ diffusion rates resulting in higher O₂ reading and shorter cell life. To use a 3000 series analyzer at a cell pressure other than atmospheric, the analyzer must be calibrated with a known calibration gas at the new cell pressure to adjust for the different diffusion rate. Cell pressures below 2/3 atmospheric are not recommended because as they tend to cause excessive internal expansion which may result in seal failure.

For operation at cell pressures other than atmospheric care must be taken not to change the sample pressure rapidly or cell damage may occur. For cell pressures above atmospheric, caution must be exercised to avoid overpressuring the cell holder. (percent analyzers will require some type of cell retainer to prevent the cell from being pushed out by the pressure.) For operation at pressures below atmospheric pressure a suffix C (clamped) cell is required.

RESTRICTION DEVICES:

For proper operation, all 3000 series analyzers require a flow restriction device. This device is typically a restrictor or a valve. This restriction device serves two functions in the sample path. The first function is to limit the flow rate of the sample through the analyzer. A restrictor is chosen to operate over a range of pressures and provide a useable flow rate over that range.

The second function that the restriction device provides is a pressure drop. This device is selected to provide the only significant pressure drop in the sample path.

RESTRICTOR KIT

The current revision of the 3000 series analyzers are supplied with a kit containing two restrictors and a union which are user installed. These parts supplied to give the end user more flexibility when installing the analyzer. The restrictor kit is suitable for high and low positive pressure applications as well as vacuum service (atmospheric pressure sample) applications (see manual for installation instructions). The standard restrictor (BLUE DOT) is recommended for pressures between 5 PSIG and 50 PSIG. For positive low pressure application (5 psig or less) the un-marked restrictor is better suited . For non-pressurized sample applications the marked restrictor should be used and configured for vacuum service. Note: for extremely low positive pressure applications (less then 2 psig) the vacuum service configuration should provide higher performance (higher flow rates). For vacuum service the end user must supply a vacuum pump and a by-pass valve for the pump. A vacuum level of 5 -10 inches of mercury should provide the optimum flow rate. **CAUTION: flow restrictors have very small orifices and may be plugged by small particles (.005" dia or larger) A sample filter must be included in the sample line prior to the restrictor! (a 60 micron filter is recommended)**

3020P EXAMPLES:

Example 1, with a incoming pressure of 10 psig the std restrictor (blue dot) will provide a flow rate of .76 SLPM. Up-stream of the restrictor the sample line pressure will be 10 psig, while down stream (including the cell) the pressure will be at atmospheric pressure.(analyzer vented to atmospheric pressure) Note, all other pressure drops in the sample path are insignificant at these flow rates. This insures that the cell operates at atmospheric pressure. At very high flow rates (off scale of flow-meter), pressure drops other than the restriction device could become significant, and result in pressurizing the cell.

Example 2, A 3020P is configured for vacuum service as follows. The un-marked restrictor is placed in the sample vent port. The down stream end of the restrictor is then connected to a vacuum pump and by-pass valve. The by-pass valve is adjusted to provide a flow rate of 1 SLPM. The sample pressure between the pump and the restrictor will be approximately -7 inches of mercury, while the pressure in the balance of the sample system including the cell will be approximately at atmospheric pressure. (provided the sample flow into the analyzer is not blocked.)

BY-PASS:

To improve the system response, a by-pass can be added to increase the sample flow rate to the analyzer by a factor of ten. A by-pass provides a sample flow path around the analyzer of 2 - 18 SCFH. typically.

CALIBRATION GAS:

3000 series analyzer requirements for units with Auto-Cal options. The customer must supply a control valves (or restrictors) for any SPAN or ZERO gas source which is attached to the Auto-Cal ports. The valve should be adjusted to the same flow rate as the sample gas . When restrictors are used, the gas pressure must be adjusted to achieve the proper flow rate.

OPERATION WITHOUT A RESTRICTOR DEVICE:

Operation without a restrictor device is not recommend as mentioned above. A 3020P without any flow restrictor device was tested on 11-19-97. This results in a flow rate of 2.4 SLPM @ 1 PSIG. This is a cv of 0.023 for the standard sample sys.

REFERENCE: FLOW_1.XLS & FLOW_2.XLS for information on flow rates at various pressures.

TAI PART NUMBERS

RESTRICTOR KIT:	A68729	
UNION (SS)	U11	
LP.RESTRICTOR	R2323 (LOW PRESSURE / VAC. SERVICE)	
STD..RESTRICTOR	R2324	BLUE DOT
NUT	N73	
FERRULE	F73	
FERRULE	F74	BOTH FERRULES ARE REQUIRED

CONVERSIONS:

1 PSI	=	2.04 INCHES OF MERCURY (in. Hg.)
1 SCFH	=	0.476 SLPM

A-5 Zero Cal

The ZERO function on the MAIN MENU is used to enter the zero calibration function. Zero calibration can be performed in either the automatic or manual mode. In the **automatic** mode, an internal algorithm compares consecutive readings from the sensor to determine when the output is within the acceptable range for zero. In the **manual** mode, the operator determines when the reading is within the acceptable range for zero.

Make sure the zero gas is connected to the instrument.

If you have trouble zeroing, you may need to skip to section 4.8.1.3 *Cell Failure*.

Auto Mode Zeroing

Select ZERO to enter the ZERO function. The ZERO screen allows you to select whether the zero calibration is to be performed automatically or manually. Use the DOWN/UP control to toggle between AUTO and MAN zero settling. Stop when AUTO appears on the display.

```
Zero: Settling: AUTO
<ENT> To Begin
```

ENTER to begin zeroing.

```
#### % Zero
Slope=#### ppm/s
```

The beginning zero level is shown in the upper left corner of the display. As the zero reading settles, the screen displays and updates information on Slope (unless the Slope starts within the acceptable zero range and does not need to settle further).

Then, and whenever Slope is less than 0.08 for at least 3 minutes, instead of Slope you will see a countdown, such as 1 Left, 0 Left. These are steps in the zeroing process that the system must complete, AFTER settling, before it can go back to ANALYZE.

```
#### % Zero
1 Left=### ppm/s
```

The zeroing process will automatically conclude when the output is within the acceptable range for a good zero. Then the analyzer automatically returns to the ANALYZE screen.

Manual Mode Zeroing

ENTER the ZERO function. The screen that appears allows you to select between automatic or manual zero calibration. Use DOWN/UP to toggle between AUTO and MAN zero settling. Stop when MAN appears on the display.

Zero: Settling: Man
<ENT> To Begin

ENTER to begin the zero calibration. After a few seconds the first of five zeroing screens appears. The number in the upper left hand corner is the first-stage zero offset. The microprocessor samples the output at a predetermined rate. It calculates the differences between successive samplings and displays the rate of change as Slope= a value in parts per million per second (ppm/s).

% Zero
Slope=#### ppm/s

NOTE: It takes several seconds for the true Slope value to display. Wait about 10 seconds. Then, wait until Slope is sufficiently close to zero before using ENTER to finish zeroing.

Generally, you have a good zero when Slope is less than 0.05 ppm/s for about 30 seconds. When Slope is close enough to zero, ENTER it. In a few seconds, the screen will update.

Once zero settling completes, the information is stored in the microprocessor, and the instrument automatically returns to the ANALYZE screen.

A-4 Material Safety Data Sheet

Section I – Product Identification

Product Name: Micro-Fuel Cells and Super Cells, all classes except A-2C, A-3, and A-5.

Electrochemical Oxygen Sensors, all classes except R-19.
Mini-Micro-Fuel Cells, all classes.

Manufacturer: Teledyne Analytical Instruments

Address: 16830 Chestnut Street
City of Industry, CA 91749

Phone: (818) 961-9221

Customer Service: Extension 222

Environmental Health and Safety: Extension 230

Customer Srvce 24 Hr Emergency: 1-800-759-7243 (Pager)

Date Prepared : 04/26/95

Section II – Hazardous Ingredients/Composition

Material or Component TLV	C.A.S. #	Quantity	OSHA PEL	ACGIH
Lead (Pb)	7439-92-1	3–20 gms	0.05 mg/m ³	0.15 mg/m ³
Potassium Hydroxide Solution 15% (KOH)	1310-58-3	1–5 ml	None	2 mg/m ³

Section III – Physical/Chemical Characteristics

Material Appearance or Component	Boiling Point (°C)	Specific Gravity	Vapor Pressure	Melting Point (°C)	Density	Evap. Rate	Solubility in Water	Odor
Lead	1744	11.34	na	328	na	na	Insoluble	Solid, silve gray, odorl
Potassium Hydroxide	1320	2.04	na	360	na	na	Complete	White or slightly yellow, no odor

Section IV – Fire and Explosion Hazard Data

Flash Point: na **Flammable Limits:** na **LEL:** na **UEL:** na

Extinguishing Media: Use extinguishing media appropriate to surrounding fire conditions. No specific agents recommended.

Special Fire Fighting Equipment: Wear NIOSH/OSHA approved self-contained breathing apparatus and protective clothing to prevent contact with skin and eyes.

Unusual Fire and Explosion Hazards: Emits toxic fumes under fire conditions.

Section V – Reactivity Data

Stability: Stable

Incompatibilities: Aluminum, organic materials, acid chlorides, acid anhydrides, magnesium, copper. Avoid contact with acids and hydrogen peroxide > 52%.

Hazardous Decomposition of Byproducts: Toxic fumes

Hazardous Polymerization: Will not occur.

Conditions to Avoid:

Section VI – Health Hazard Data

Routes of Entry: **Inhalation:** Highly unlikely

Ingestion: May be fatal if swallowed.

Skin: The electrolyte (potassium hydroxide) is corrosive; skin contact may cause irritation or chemical burns.

Eyes: The electrolyte (potassium hydroxide) is corrosive; eye contact may cause irritation or severe chemical burns.

Acute Effects: The electrolyte is harmful if swallowed, inhaled or adsorbed through the skin. It is extremely destructive to tissue of the mucous membranes, stomach, mouth, upper respiratory tract, eyes and skin.

Chronic Effects: Prolonged exposure with the electrolyte has a destructive effect on tissue.

Chronic exposure to lead may cause disease of the blood and blood forming organs, kidneys and liver, damage to the reproductive systems and decrease in fertility in men and women, and damage to the fetus of a pregnant woman. Chronic exposure from the lead contained in this product is extremely unlikely.

Signs and Symptoms of Exposure:	Contact of electrolyte with skin or eyes will cause a burning sensation and/or feel soapy or slippery to touch. Other symptoms of exposure to lead include loss of sleep, loss of appetite, metallic taste and fatigue.
Carcinogenicity:	Lead is classified by the IARC as a class 2B carcinogen (possibly carcinogenic to humans)
OSHA:	Where airborne lead exposures exceed the OSHA action level, refer to <i>OSHA Lead Standard 1910.1025</i> .
NTP:	na
Medical Conditions Generally Aggravated by Exposure:	Lead exposure may aggravate disease of the blood and blood forming organs, hypertension, kidneys, nervous and possibly reproductive systems. Those with preexisting skin disorders or eye problems may be more susceptible to the effects of the electrolyte.
Emergency First Aid Procedures:	In case of contact with the skin or eyes, immediately flush with plenty of water for at least 15 minutes and remove all contaminated clothing. Get medical attention immediately. If ingested, give large amounts of water and DO NOT INDUCE VOMITING. Obtain medical attention immediately. If inhaled, remove to fresh air and obtain medical attention immediately.

Section VII – Precautions for Safe Handling and Use

NOTE: The oxygen sensors are sealed, and under normal circumstances, the contents of the sensors do not present a health hazard. The following information is given as a guide in the event that a cell leaks.

Protective measures during cell replacement:	Before opening the bag containing the sensor cell, check the sensor cell for leakage. If the sensor cell leaks, do not open the bag. If there is liquid around the cell while in the instrument, wear eye and hand protection.
Cleanup Procedures:	Wipe down the area several times with a wet paper towel. Use a fresh towel each time. Contaminated paper towels are considered hazardous waste.

Section VIII – Control Measures

Eye Protection:	Chemical splash goggles
Hand Protection:	Rubber gloves
Other Protective Clothing:	Apron, face shield
Ventilation:	na

Section IX – Disposal

Both lead and potassium hydroxide are considered poisonous substances and are regulated under TSCA and SARA Title III.

EPA Waste Number:	D008
California Waste Number:	181
DOT Information:	RQ Hazardous Waste Solid N.O.S. (Lead) Class 9 NA3077 PG III

Follow all Federal, State and Local regulations.

Section X – References

Material Safety Data Sheets from J.T. Baker Chemical, Aldrich, Malinckrodt, ASARCO
U.S. Department of Labor form OMB No. 1218-0072
Title 8 California Code of Regulations
TSCA
SARA Title III
CFR 49
CFR 29
CFR 40

NOTE: The above information is believed to be correct and is offered for your information, consideration, and investigation. It should be used as a guide. Teledyne Brown Engineering Analytical Instruments shall not be held liable for any damage resulting from handling or from contact with the above product.

8 7 6 5 4 3 2 1

NOTES: UNLESS OTHERWISE SPECIFIED:

- ① INTERCONNECTION DIAGRAM: DWG# D-65910
- ② WIRING DIAGRAM: TRACE SERIES: DWG D-65911
PERCENT SERIES: DWG D-66067
- ③ FINAL ASSEMBLY: TRACE SERIES: DWG D-65908
PERCENT SERIES (W/ NYLON CELL BLOCK): DWG D-66066
PERCENT SERIES (W/ STAINLESS CELL BLOCK): DWG D-66050

REV	DESCRIPTION	DATE	APP.	REV.
0	Initial Release	04/09/96	SB	--
1	INC. ECO 99-0249	12/1/00	AA	JCR



This drawing must not be changed without the approval of Factory Mutual Research Corp.

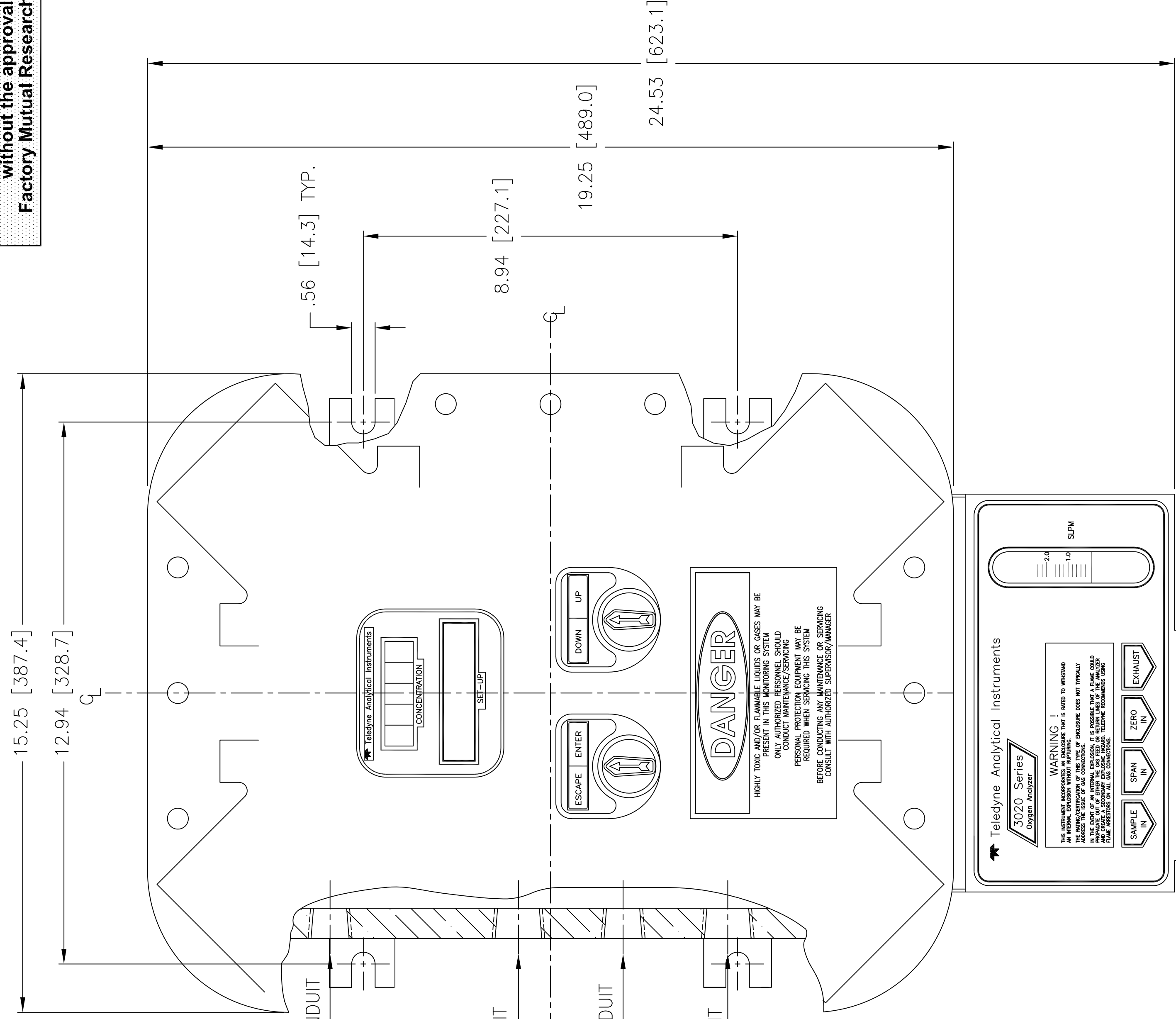
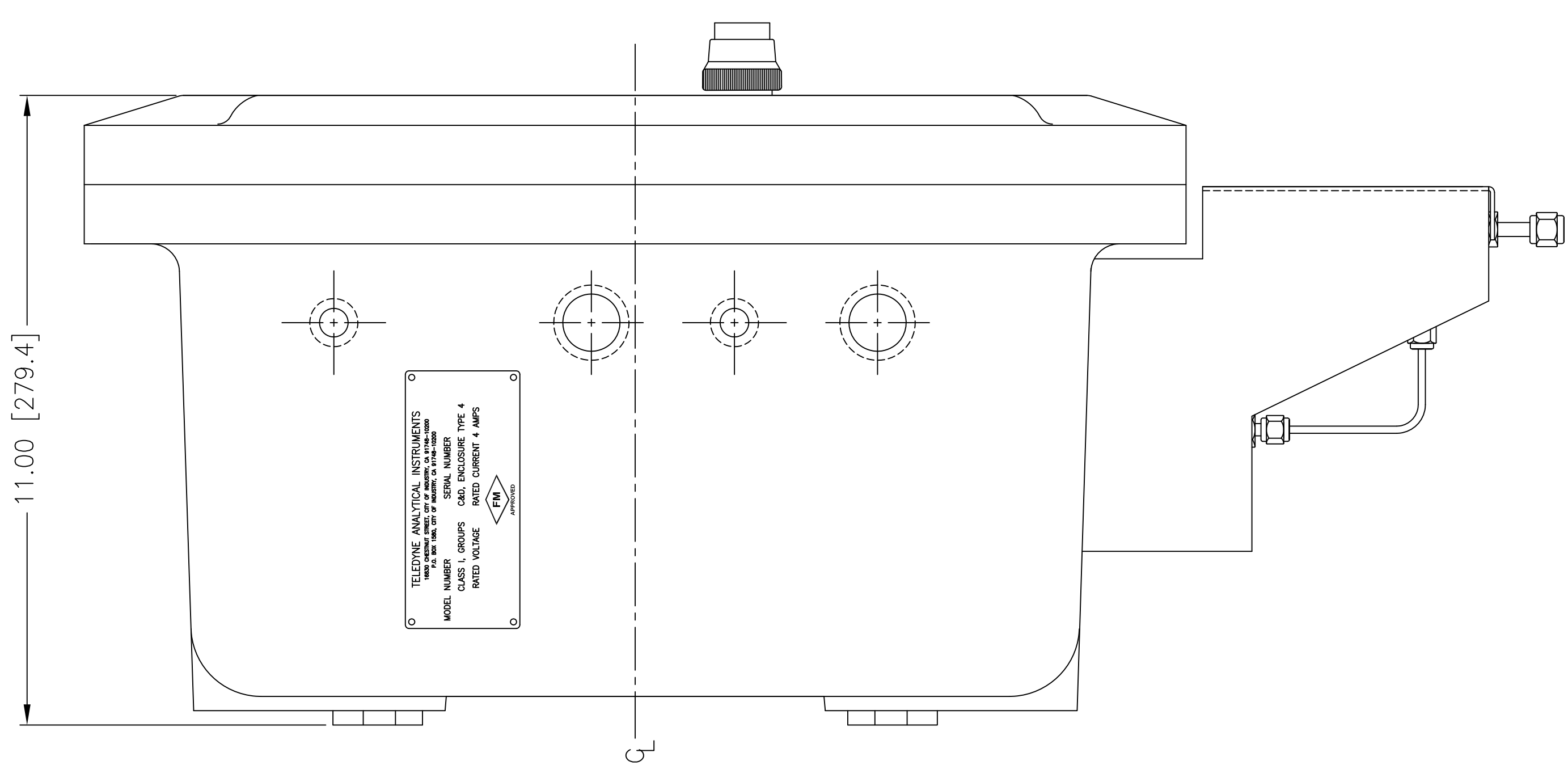

- ALARM OUTPUTS: 3/4" NPT CONDUIT
- DIGITAL INPUT SPAN / ZERO CAL. CONTACT RANGE ID CONTACTS RS-232: 1" NPT CONDUIT
- AC POWER IN 50/60 HZ 115/230 V: 3/4" NPT CONDUIT
- SOLENOID RETURN ANALOG OUTPUTS REMOTE SENSOR NET WORK: 1" NPT CONDUIT
- SAMPLE IN: 1/4 TUBE FITTING
- SPAN IN: 1/4 TUBE FITTING
- ZERO IN: 1/4 TUBE FITTING
- EXHAUST: 1/4 TUBE FITTING

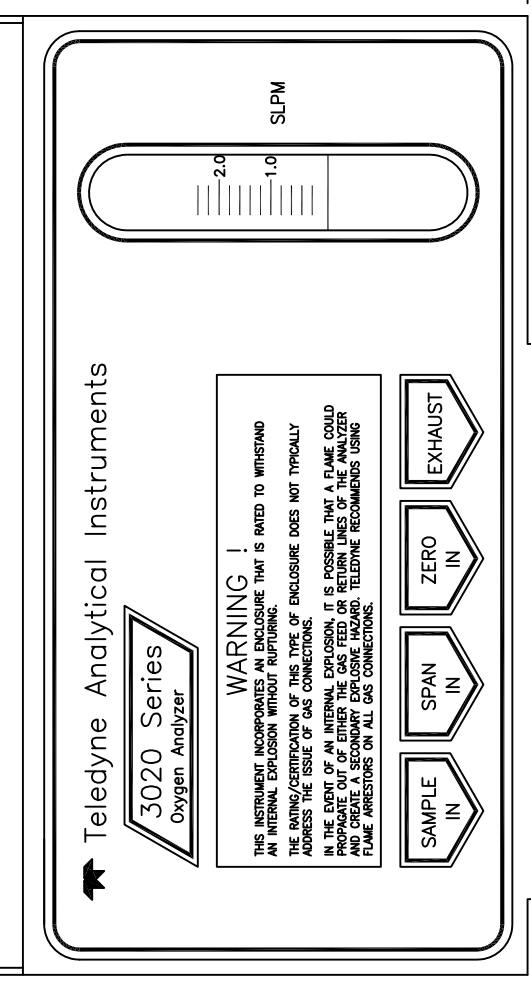

DO NOT SCALE DWG INFORMATION. IT IS NOT TO BE COPIED, REPRODUCED OR USED WITHOUT WRITTEN PERMISSION.

W/ NOTED	SIGNATURES	DATE	TITLE	SCALE
N/		11/07/95	TELEDYNE INSTRUMENTS Analytical Instruments	1:2
I/ NOTED			Teledyne Technologies Company	SIM NONE
O/			City of Industry, California, 91746, USA	SHEET 1 OF 1
P/				REV
F/ NOTED				
REFERENCE	CAD ID: D65909-1			

DO NOT SCALE DWG INFORMATION. IT IS NOT TO BE COPIED, REPRODUCED OR USED WITHOUT WRITTEN PERMISSION.
TELEDYNE INSTRUMENTS Analytical Instruments
Teledyne Technologies Company
City of Industry, California, 91746, USA
MODEL 3020 OXYGEN ANALYZER OUTLINE DIAGRAM
DWG NO. D-65909

D

C

B

A

8 7 6 5 4 3 2 1

NOTES: UNLESS OTHERWISE SPECIFIED.

① THIS DRAWING IS ISSUED FOR PERCENT SERIES.

FM

APPROVED

PERCENT EDITION

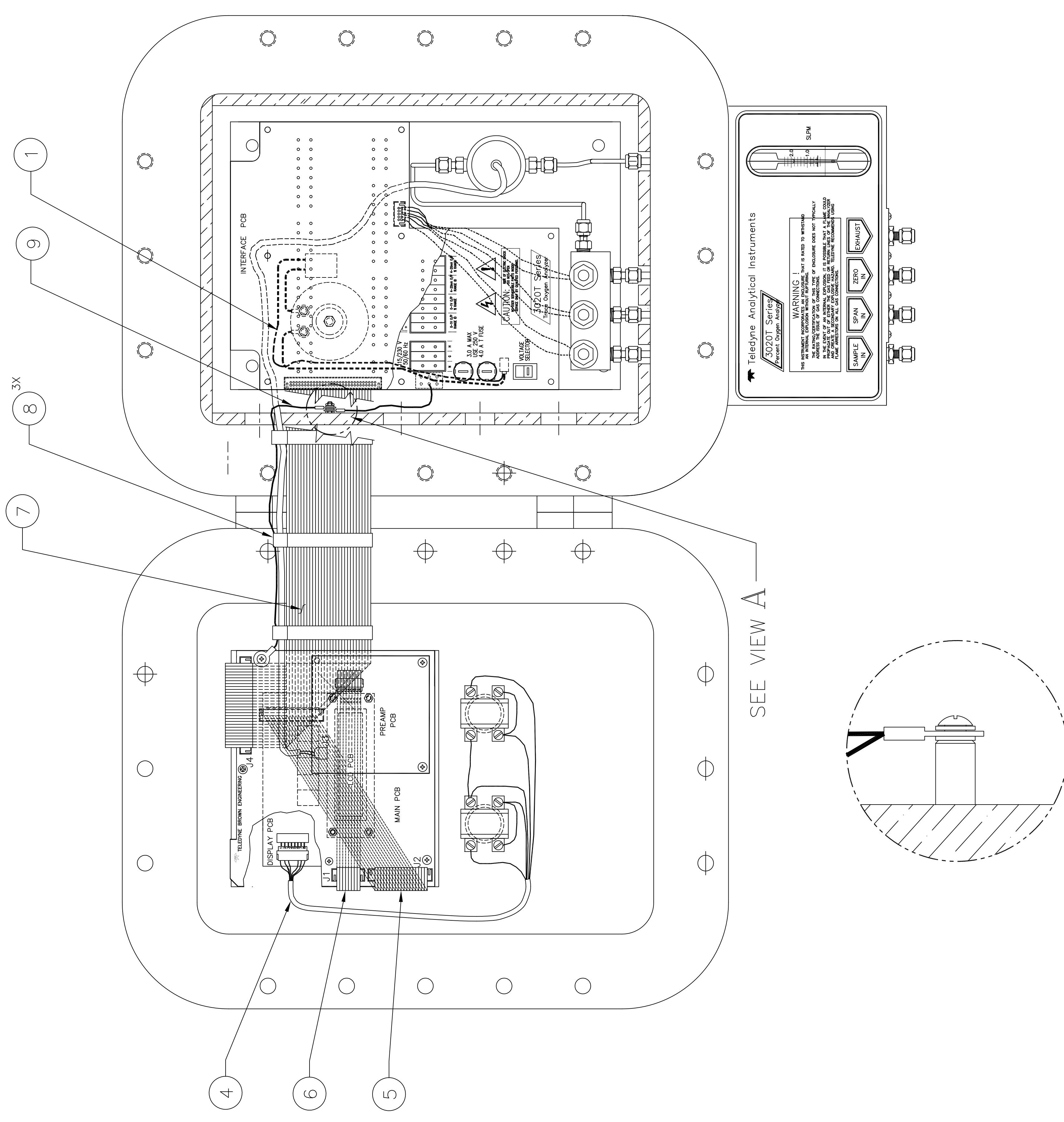

SEE VIEW A

VIEW A
 WIRING DIAGRAM
 DOOR OPENED
 SCALE: NONE

REV	DESCRIPTION	DATE	APP.	REV.
4	INC ECO 00-0064	3/15/00	AA	DC
5	INC ECO 04-0157	10/5/04	AA	VF

ITEM	QTY	PART NO.	DESCRIPTION
10			
9	1	B-65921	GROUNDING WIRNG ASSY
8	3	CP 1787	CABLE CLIP
7	1	B-65913	RIBBON CABLE ASSY (MAIN PCB - CUSTOMER INTERFACE PCB)
6	1	B-65912	RIBBON CABLE ASSY (MAIN PCB - DISPLAY PCB)
5	1	B-65914	WIRING ASSY (MAIN PCB - DISPLAY PCB)
4	1	B-65916	WIRING ASSY (CONTROL SWITCHES - DISPLAY PCB)
3			
2			
1	REF	B-65918	WIRING ASSEMBLY (HEATER TO CUSTOMER INTERFACE PCB)

BILL OF MATERIAL	
DO NOT SCALE DWG	THIS DRAWING IS THE PROPERTY OF TELEDYNE INSTRUMENTS AND CONTAINS CONFIDENTIAL INFORMATION. IT IS NOT TO BE COPIED, REPRODUCED OR USED WITHOUT WRITTEN PERMISSION.
TOLERANCE UNLESS OTHERWISE SPECIFIED	TELEDYNE INSTRUMENTS Analytical Instruments A Teledyne Technologies Company 5711 S. UNIVERSITY AVENUE, DENVER, CO 80202
ANGULAR ±1/2°	
LINEAR ±.010	
±.1	
±.01	
±.005	
±.002	
SIGNATURES	DATE
DRAFT: BILL TARNIG	2/29/96
CHK: [Signature]	
APPR: BILL TARNIG	4/9/96
ENGR: WILLIAM TARNIG	
C.O. [Signature]	
REFERENCE	CAD ID: DB6067-5
TITLE	SCALE
ASSEMBLY WIRING DIAGRAM	1:1
OXYGEN ANALYZER	SM
MDL 3020P	SHEET
	1 OF 1
	REV
	5
	DWG NO. D-66067
	LISTED

NOTES: UNLESS OTHERWISE SPECIFIED:

- 1 WEIGHT: 96 LBS
- 2 WIRING DIAGRAM: D-66067
- 3 INTERCONNECTION DIAGRAM: D-65910
- 4 OUTLINE DIAGRAM: D-65909
- 5 ITEMS 12, 17 & 19 ARE NOT SHOWN ON THIS DRAWING.

LEGEND
(NYLON SENSOR BLOCK)

SYMBOL	FUNCTION
A	3020P
B	3020P-CV
C	3020P-MA
D	3020P-MA
E	3020P-MA
F	3020P-CV-MA
G	3020P-CV-MA
H	3020P-FAB
I	3020P-FAB
J	3020P-CV-FAB
K	3020P-CV-FAB
L	3020P-MA-FAB
M	3020P-MA-FAB
N	3020P-MA-FAB
O	3020P-CV-MA-FAB
P	3020P-FACD
Q	3020P-CV-FACD
R	3020P-CV-FACD
S	3020P-MA-FACD
T	3020P-MA-FACD
U	3020P-MA-FACD
V	3020P-CV-MA-FACD
W	3020P-CV-MA-FACD
X	3020P-CV-MA-FACD

3020 - MODULE NO.

P - PERCENT

CV - CONTROL VALVE

FAB - GRP B FLAME ARRESTOR

FACD - GRP C&D FLAME ARRESTOR

MA - MILLI. AMP.

OPTION LIST

OPTION ITEM NO.	QUANTITY																				DESCRIPTION	PART NO.				
	A	B	C	D	E	F	G	H	I	J	K	L	M	N	O	P	Q	R	S	T			U	V	W	X
1		1																							FLOW CONN. FLOWMETER MTG. SUB-ASSY	D66043-A D66042-A D66041-A D65926-A D66043-C D66042-C D65930-A D65930-B D65919-B D65919-C ----- A67122 A 318 B65915 C-64 A73805 D66045 D66067 ----- C 245 A73957-D P966 D66066-RS A68729 A69185
2		1								1															BOX SUB-ASSEMBLY	D65930-A
3		1								1															DOOR SUB-ASSEMBLY	D65930-B D65919-B D65919-C ----- A67122
4	11	11	11	11	15	15	15	11	11	11	11	11	11												SCREW, 8-32UNC-2A X 3/8, SS	----- A67122
5	2	4	2	4									3	3											PLUG MODIFICATION	A67122
6		3		3																					MALE ADAPTER, 1/8T X 1/8 NPT, SS	A 318
7		1		1																					FLOW MANIFOLD SUBASSEMBLY	B65915
8		1		1																					CONNECTOR, 1/8T X 1/8 NPT	C-64
9		1		1																					FLAME ARRESTOR (FOR GROUP "B,C,D - ADALET")	A73805
10		1		1																					FLOW CONN. SILK-SCREEN DETAIL	D66045
11		1		1																					WIRING DIAGRAM	D66067
12		1		1																					FLAME ARRESTOR (FOR GROUP "C" & "D")	D66067
13		1		1																					TUBING, SS 1/8"	----- C 245
14	A/R	A/R	A/R	A/R	A/R	A/R	A/R	A/R	A/R	A/R	A/R	A/R	A/R	A/R	A/R	A/R	A/R	A/R	A/R	A/R	A/R	A/R	A/R	A/R	CONNECTOR, 1/8T X 1/4 NPT, SS	C 245
15	4	8	4	8	4	8	4	8	4	8	4	8	4	8	4	8	4	8	4	8	4	8	4	8	PROGRAMMED EPROM DETAIL	A73957-D P966
16	2	1	1	2																					ROUTE SHEET	D66066-RS
17	2	1	1	2																					RESTRICTOR KIT	A68729
18	REF	REF	REF	REF	REF	REF	REF	REF	REF	REF	REF	REF	REF	REF	REF	REF	REF	REF	REF	REF	REF	REF	REF	TAG DETAIL	A69185	
19	1	1	1	1	1	1	1	1	1	1	1	1	1	1	1	1	1	1	1	1	1	1	1			
20	1	1	1	1	1	1	1	1	1	1	1	1	1	1	1	1	1	1	1	1	1	1	1			

5

5

REPORT NO. 1D4A7AE

REV	DESCRIPTION	DATE	APP.	REV.
10	INC ECO 01-00189	6/26/01	AA	VF
11	INC ECO 02-0287	11/19/02	AA	VF

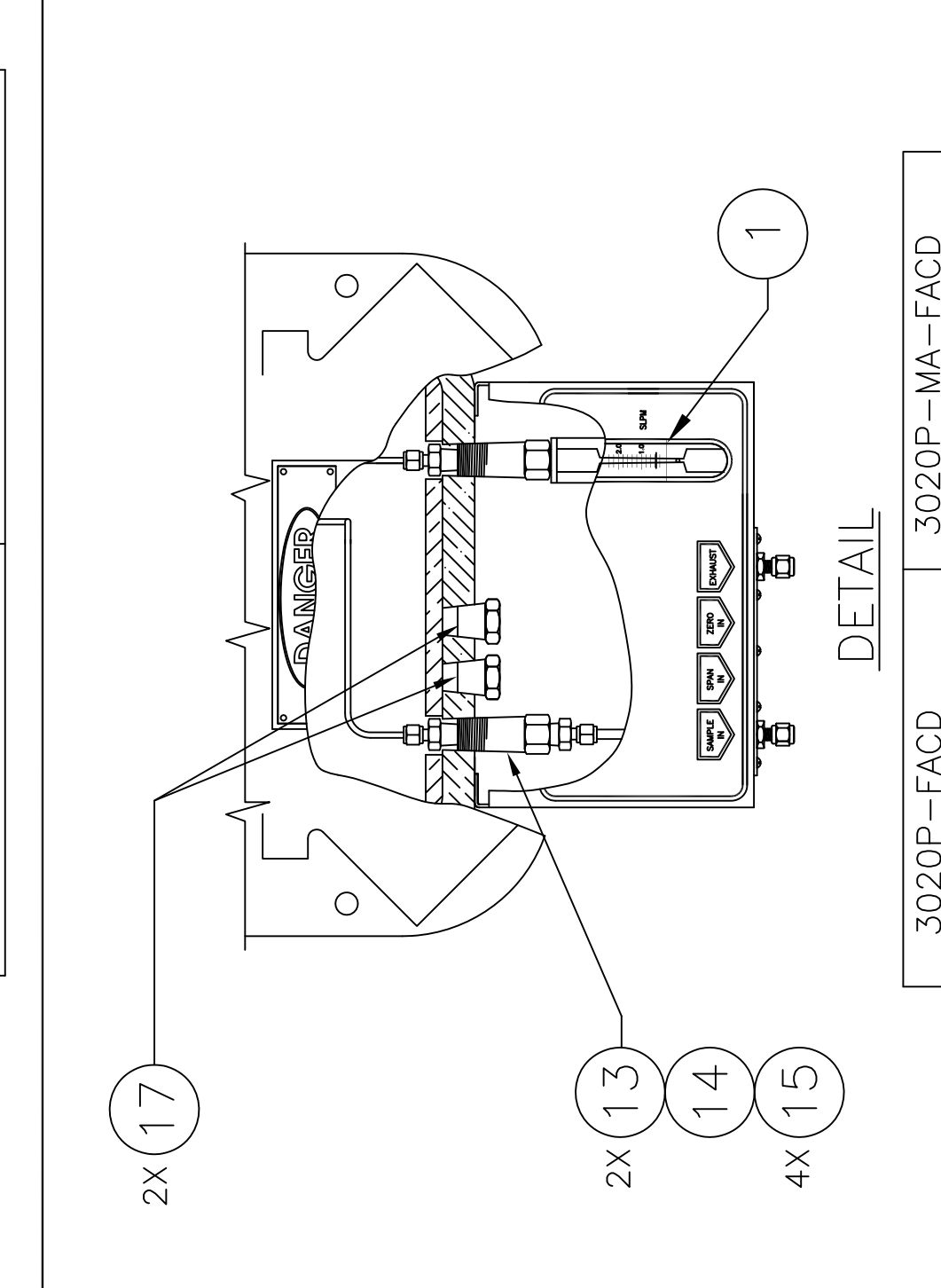
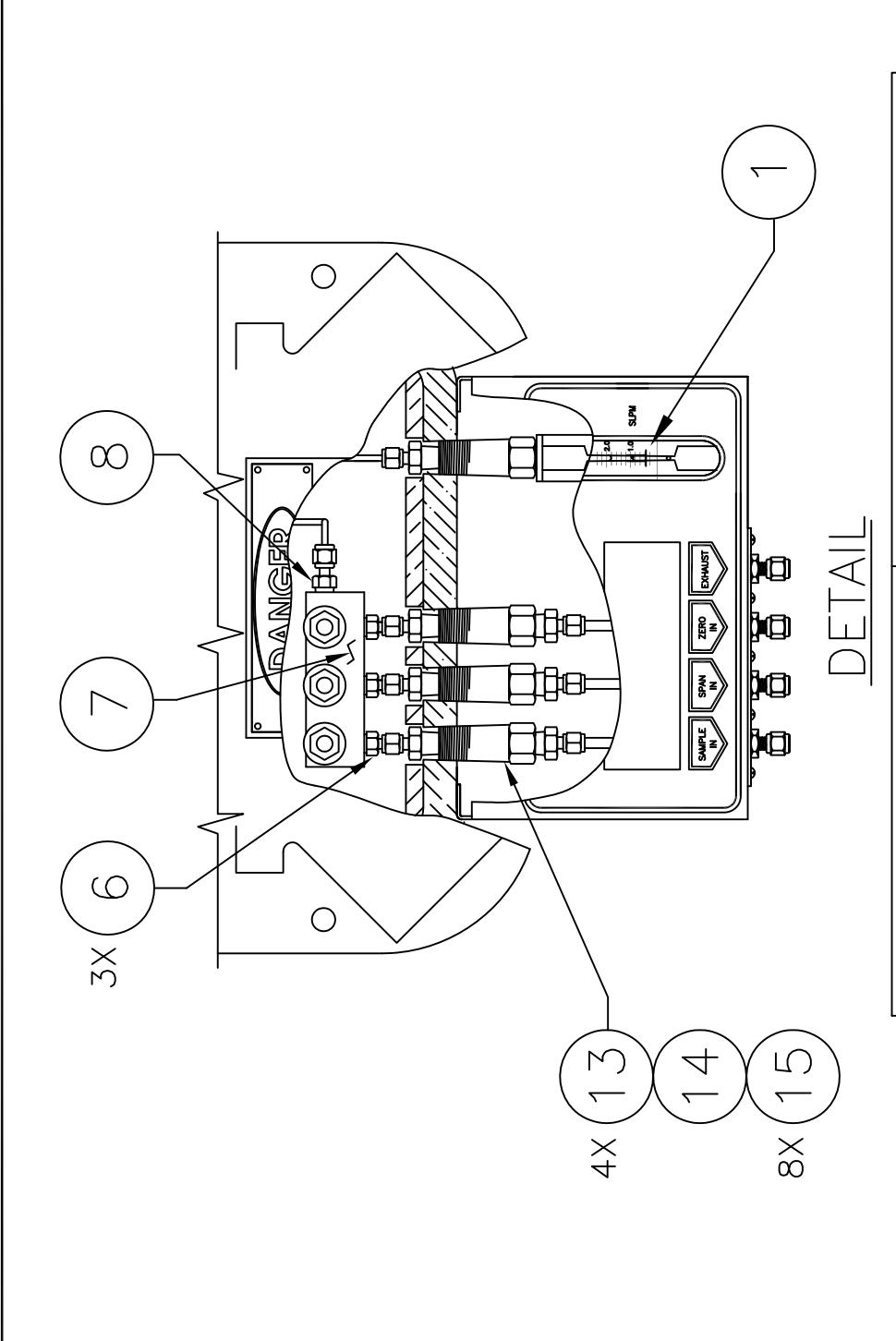
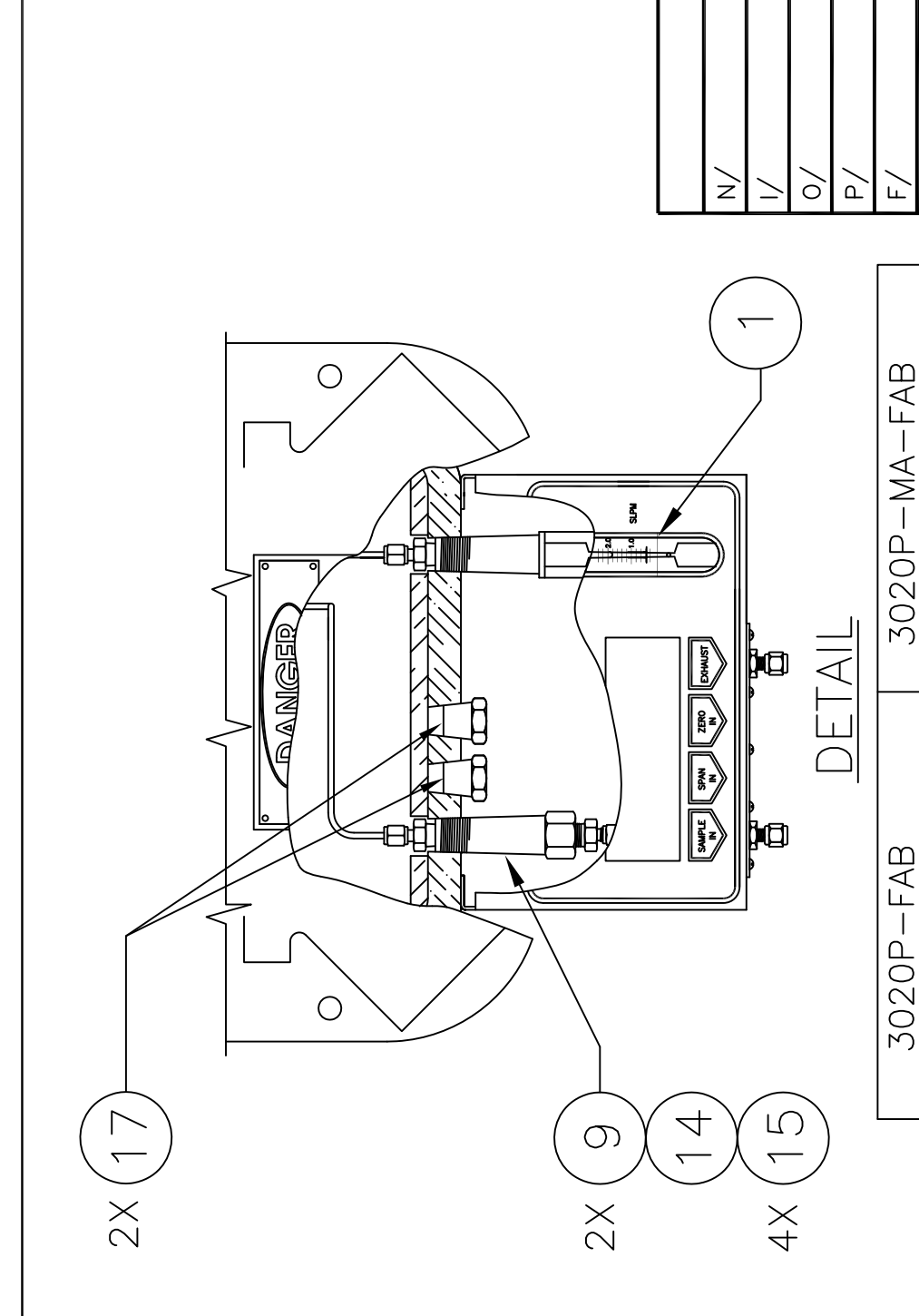
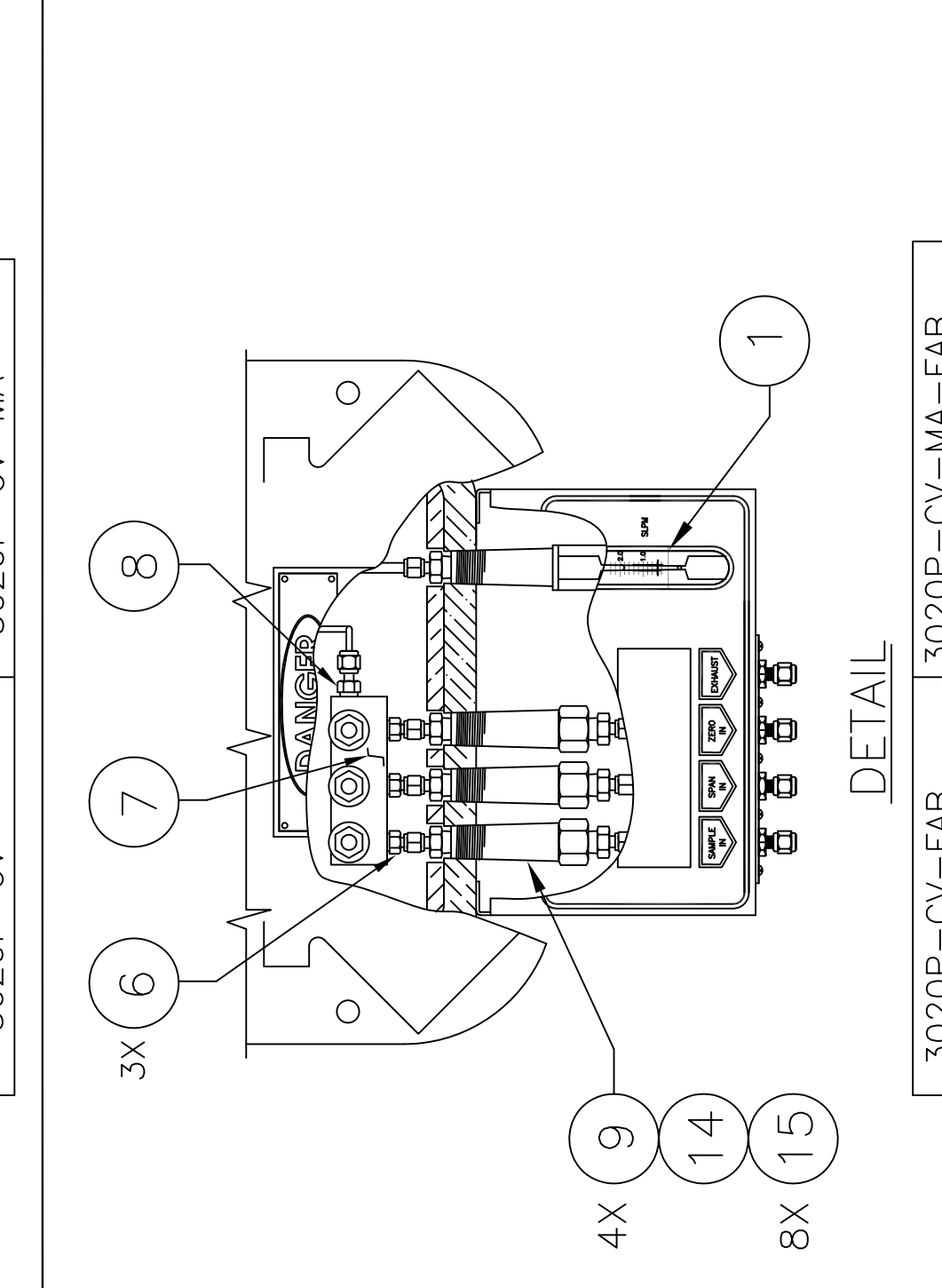
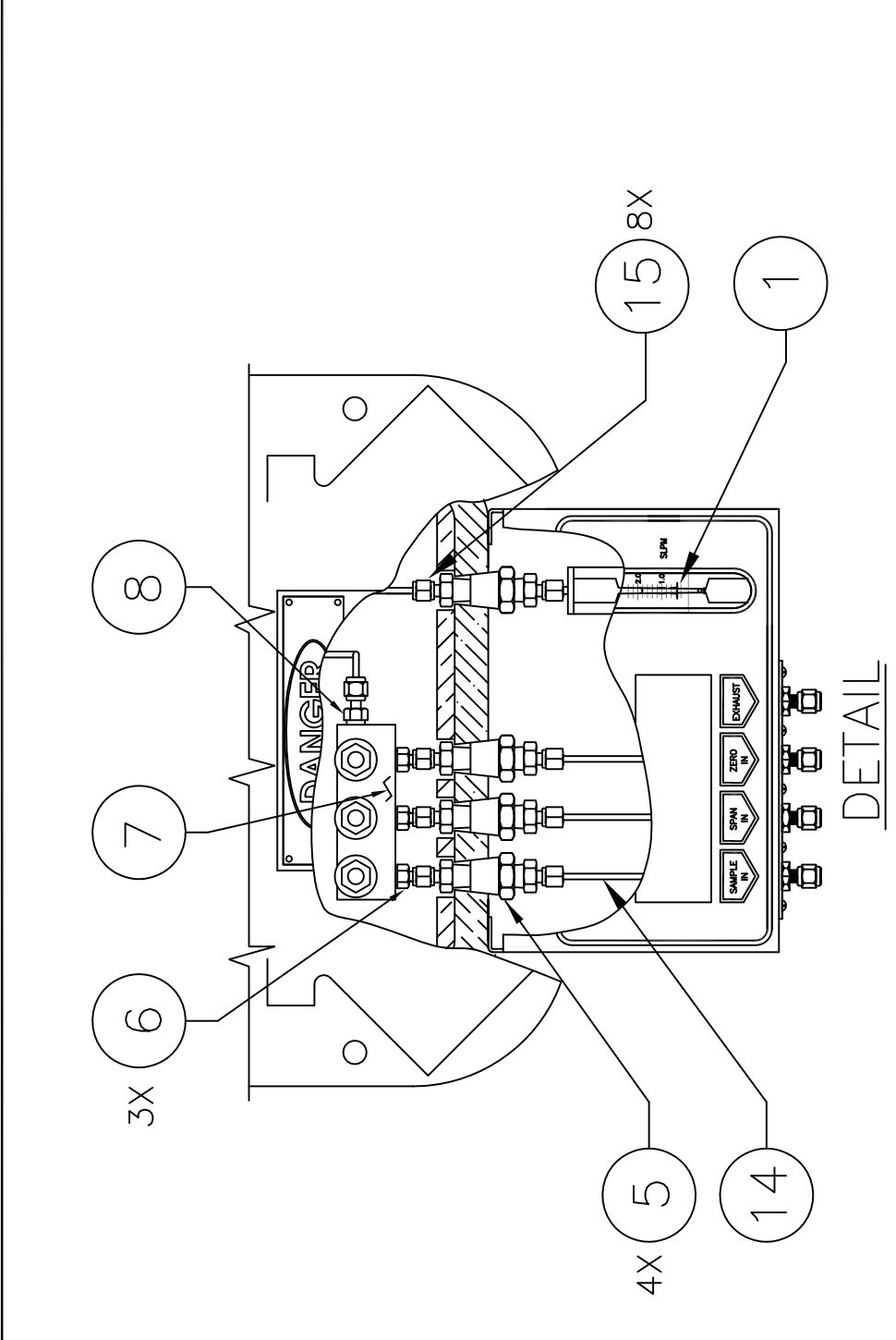
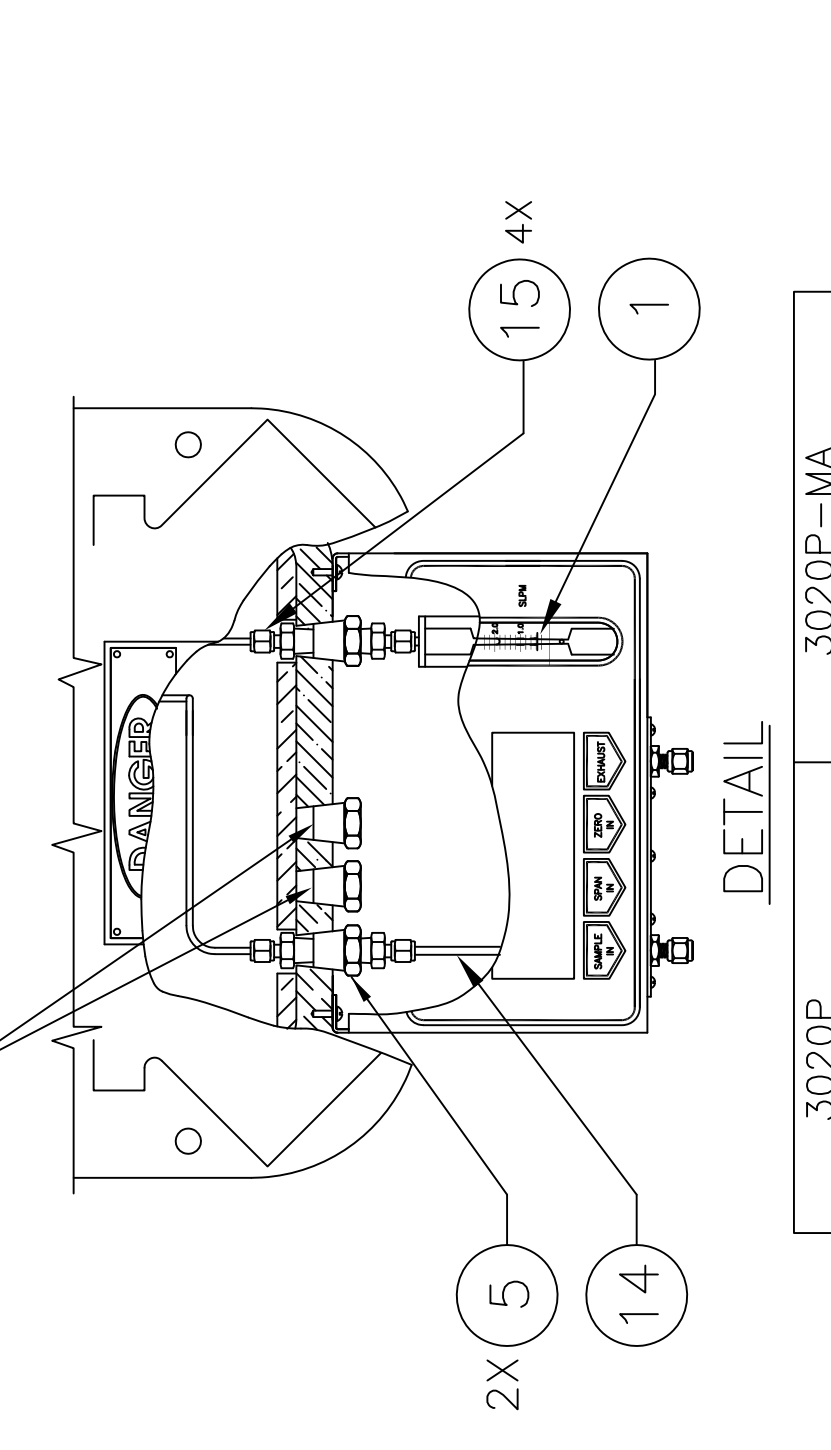
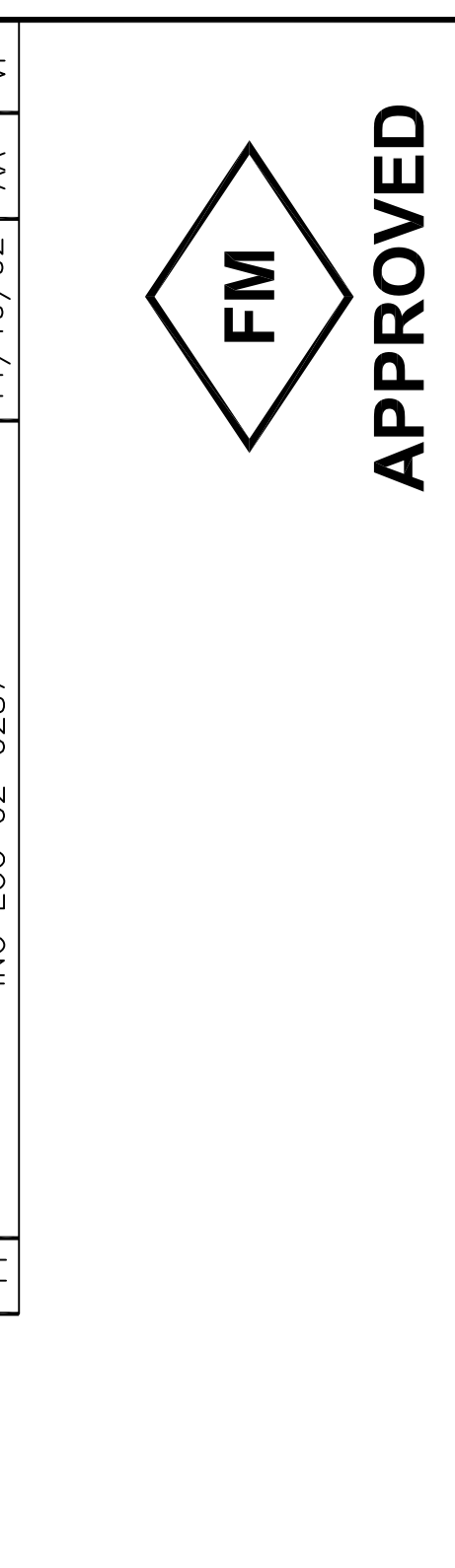

PERCENT EDITION
NYLON CELL BLOCK SERIES

ITEM	QTY	PART NO.	DESCRIPTION
N/			TITLE
V/			SCALE 1/4"
O/			SM
P/			SHEET 1 OF 1
F/			REV 11
REFERENCE			DWG NO. D-66066
			MATL. - LISTED -
			DMG NO. 1
			REV 11

BILL OF MATERIAL
THIS DRAWING IS THE PROPERTY OF TELETYPE INSTRUMENTS AND CONTAINS CONFIDENTIAL INFORMATION. IT IS NOT TO BE COPIED, REPRODUCED OR USED WITHOUT WRITTEN PERMISSION.
TELETYPE INSTRUMENTS
Analytical Instruments
A Teletype Technologies Company
501 S. RIVERVIEW, CALIFORNIA 91706

DO NOT SCALE DWG
TOLERANCE UNLESS OTHERWISE SPECIFIED: ANGULAR $\pm 1/2^\circ$
LINEAR - XX ± 1.1
LXXX ± 0.05
LXXX ± 0.10

DATE 11/7/95
SIGNATURES
DRFT: BILL TARNING
CHK: [Blank]
APPR: [Blank]
ENGR: BILL TARNING 11/7/95

MODEL 3020P
OXYGEN ANALYZER
FINAL ASSEMBLY

SCALE 1/4"
SM
SHEET 1 OF 1

DWG NO. D-66066

8

D

C

B

A

NOTES: UNLESS OTHERWISE SPECIFIED:
 ① WEIGHT: 96 LBS
 ② WIRING DIAGRAM: D-66067
 ③ INTERCONNECTION DIAGRAM: D-65910
 ④ OUTLINE DIAGRAM: D-65909
 ⑤ ITEMS 12, 17 & 19 ARE NOT SHOWN ON THIS DRAWING.
LEGEND

SYMBOL	FUNCTION
A	3020P-SS
B	3020P-CV-SS
C	3020P-CV-SS
D	3020P-SS-MA
E	3020P-CV-SS-MA
F	3020P-CV-SS-MA
G	3020P-CV-SS-MA
H	3020P-SS+-FAB
I	3020P-CV-SS-FAB
J	3020P-CV-SS-FAB
K	3020P-SS-MA-FAB
L	3020P-CV-SS-MA-FAB
M	3020P-CV-SS-MA-FAB
N	3020P-CV-SS-MA-FAB
O	3020P-CV-SS-MA-FAB
P	3020P-SS-FACD
Q	3020P-CV-SS-FACD
R	3020P-CV-SS-FACD
S	3020P-SS-MA-FACD
T	3020P-CV-SS-MA-FACD
U	3020P-CV-SS-MA-FACD
V	3020P-CV-SS-MA-FACD
W	3020P-CV-SS-MA-FACD
X	3020 - MODULE NO.
P - PERCENT	
CV - CONTROL VALVE	
FAB - GRP B FLAME ARRESTOR	
FACD - GRP C&D FLAME ARRESTOR	
MA - MILLI. AMP.	
SS - STAINLESS STEEL CELL BLOCK	

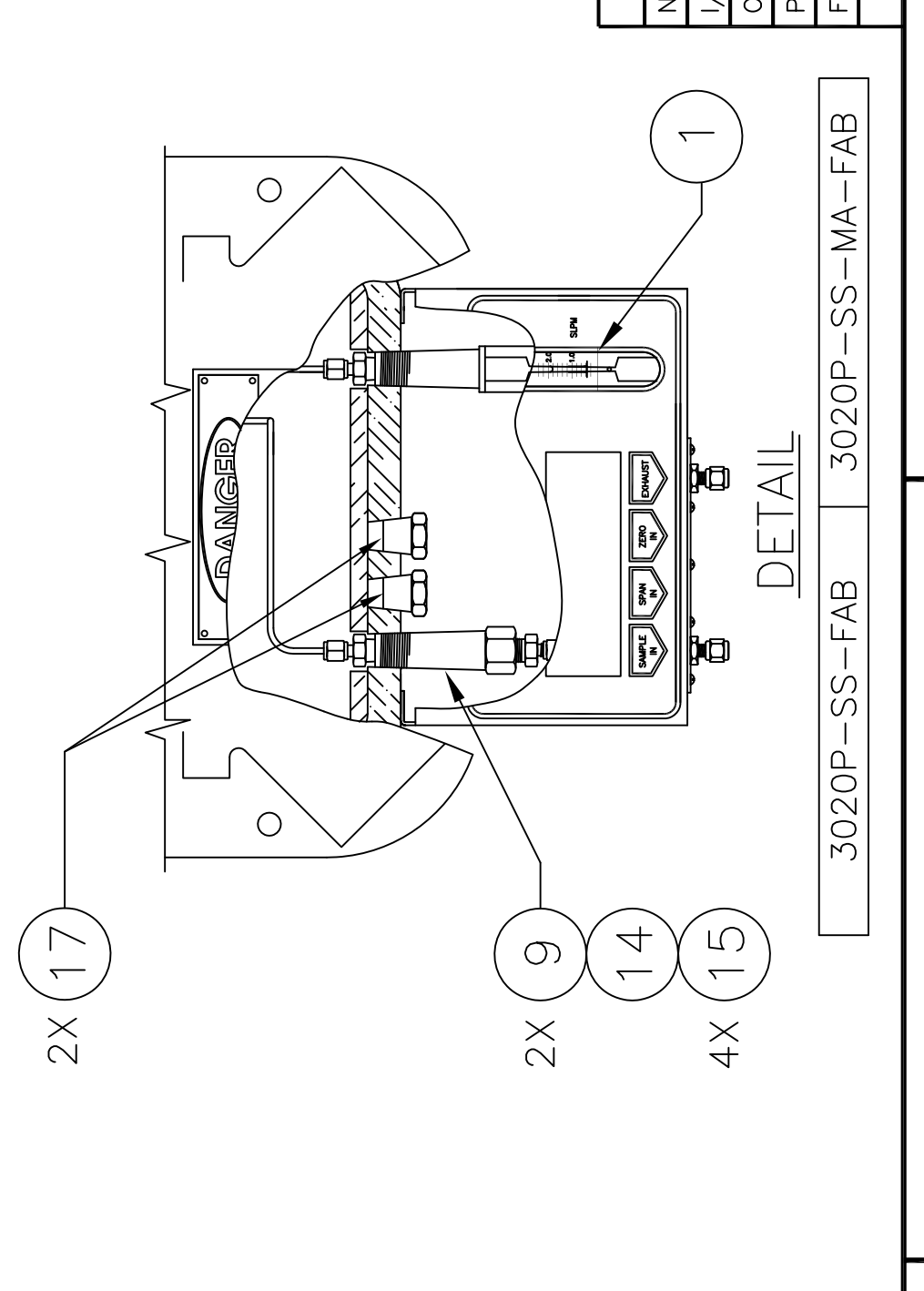
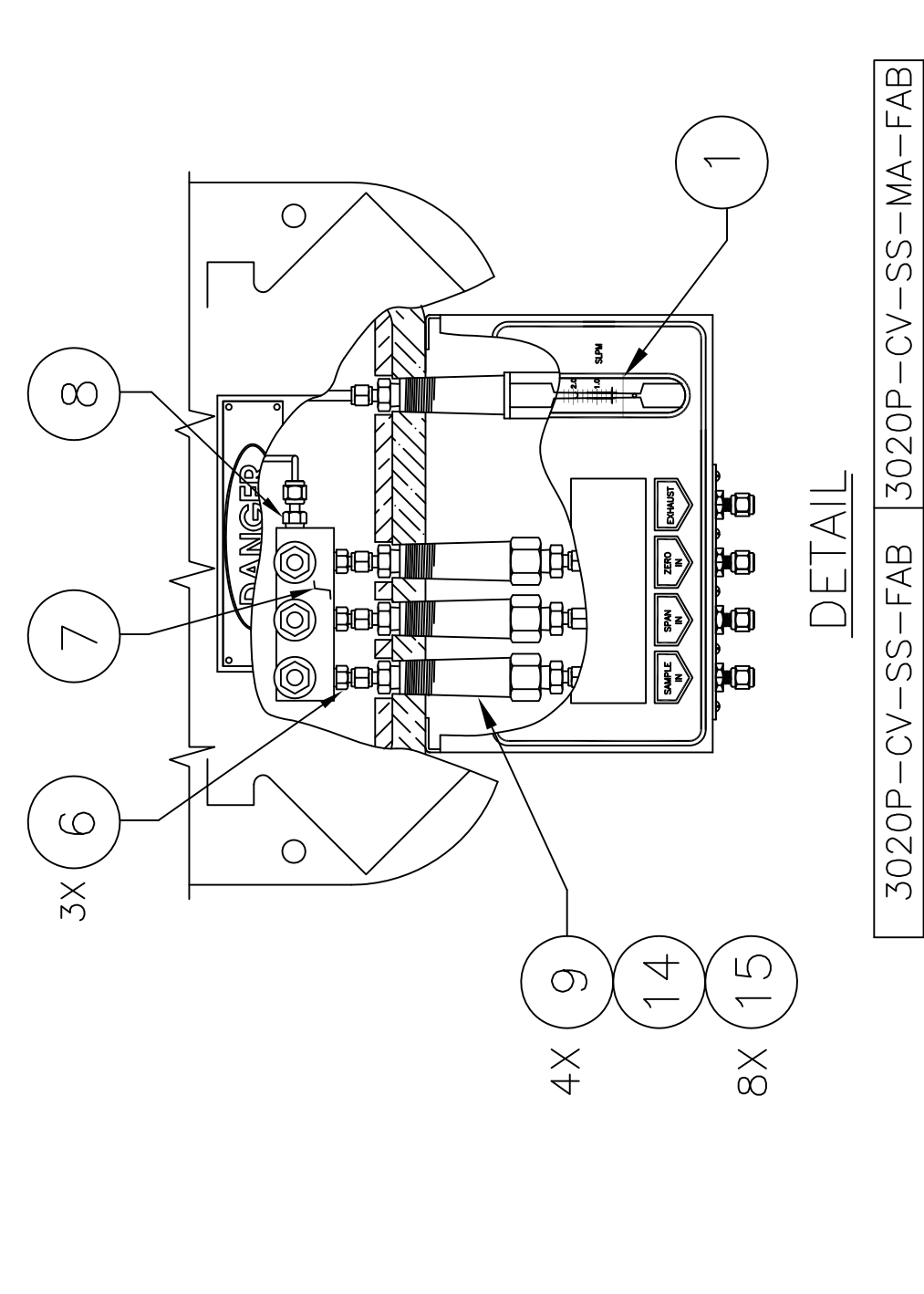
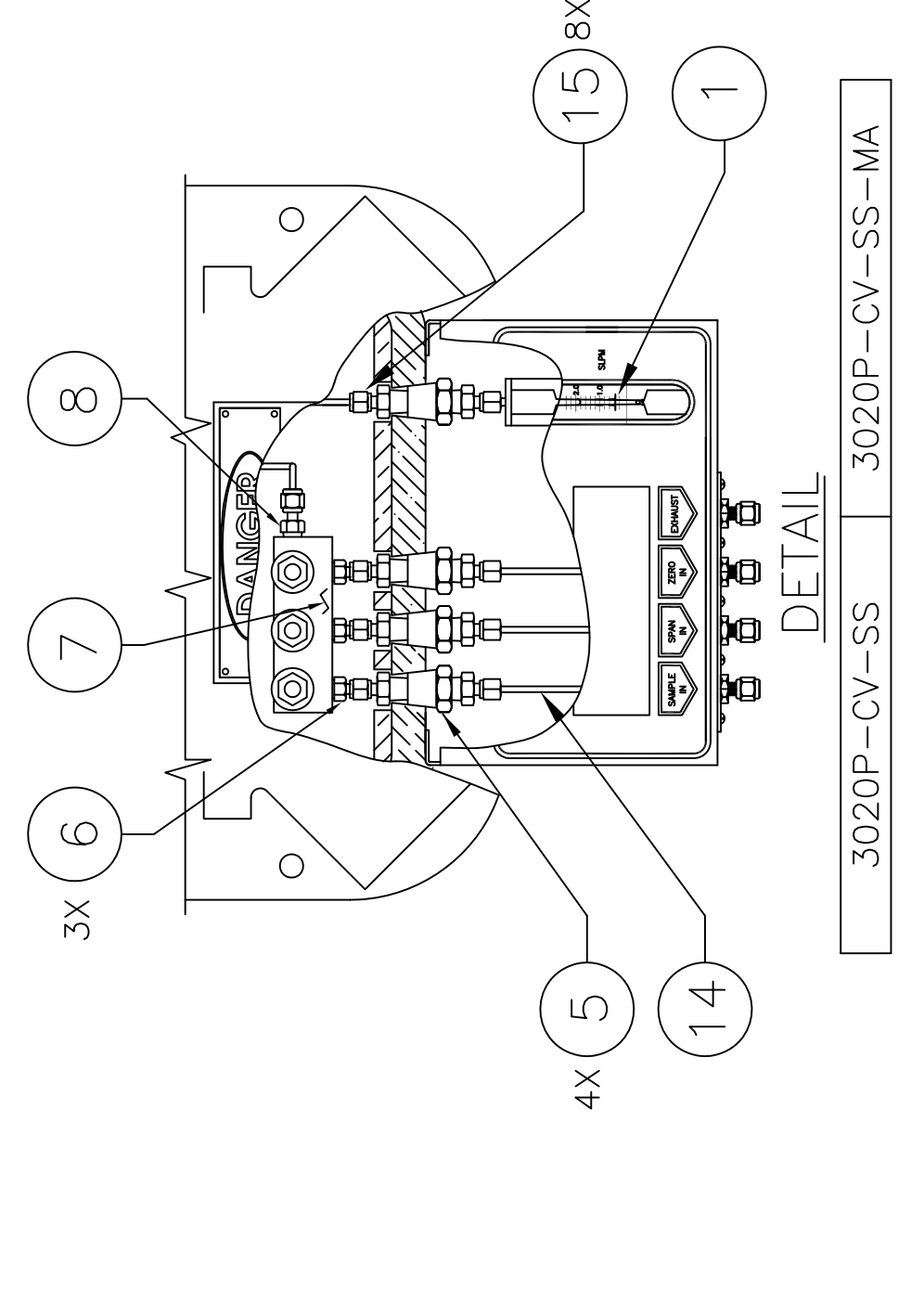
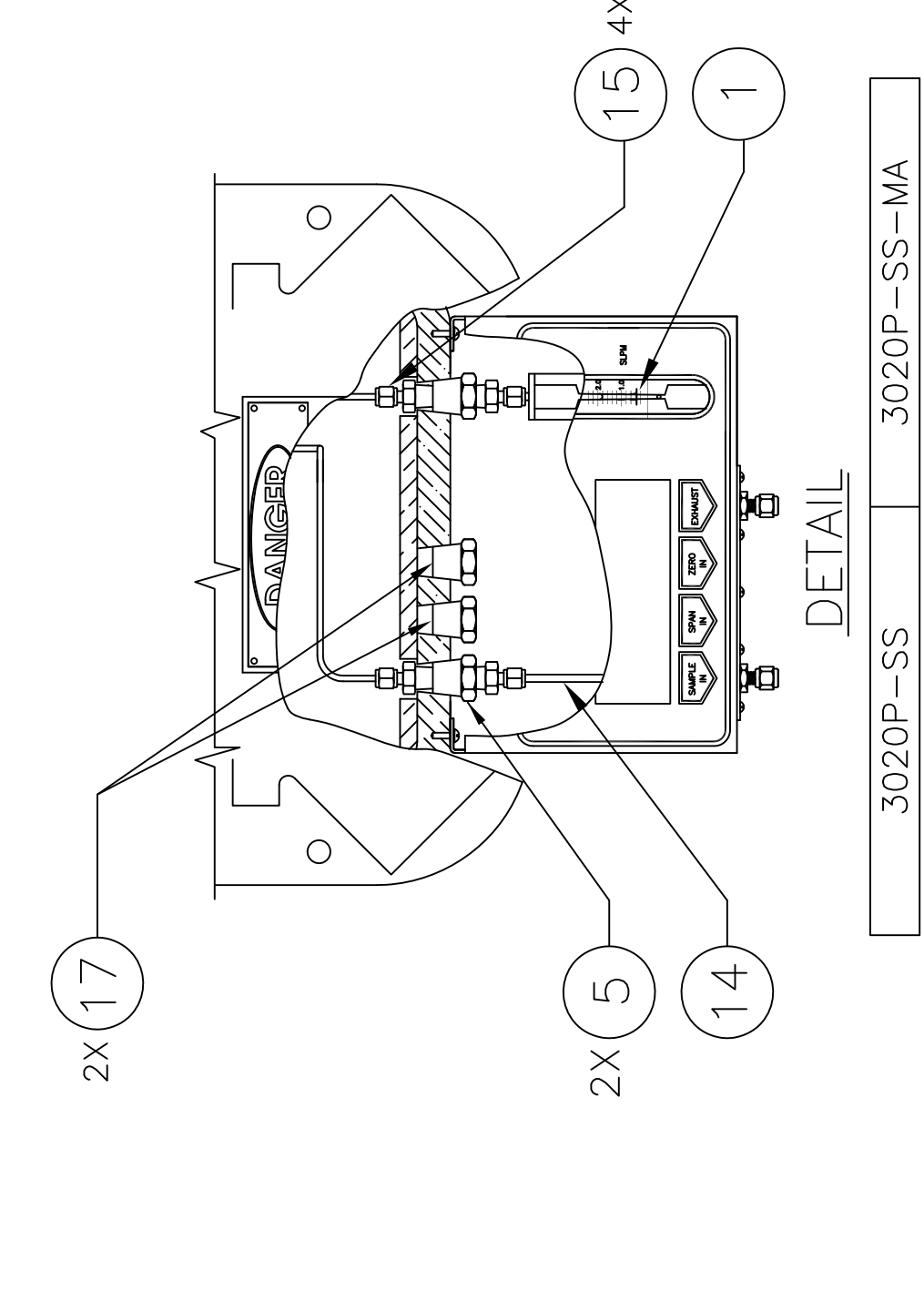
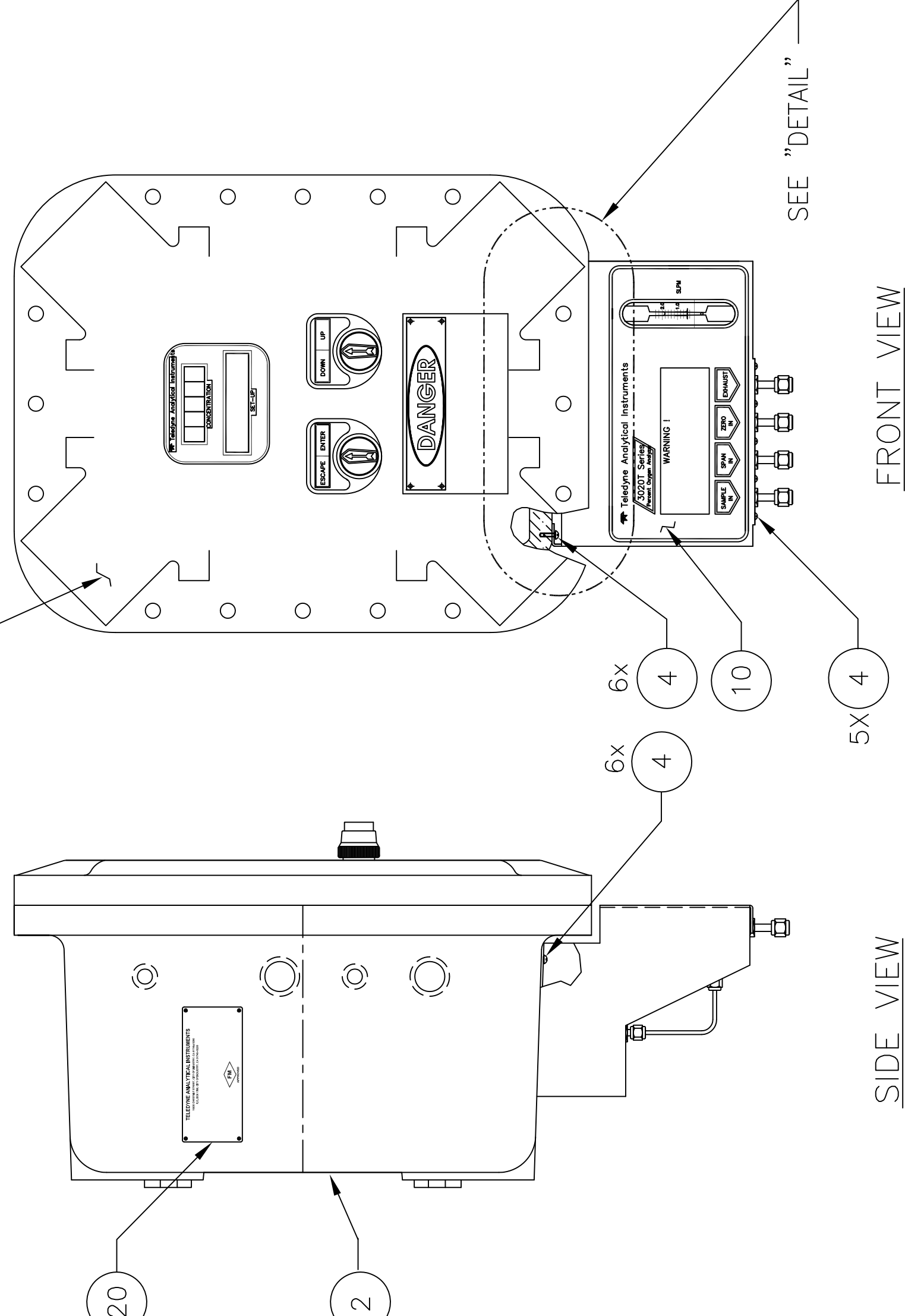

REV	DESCRIPTION	DATE	APP.	REV.
11	INC. ECO 02-0287	11/19/02	AA	VF
12	INC. ECO 04-0180	06/28/05	AR	MN

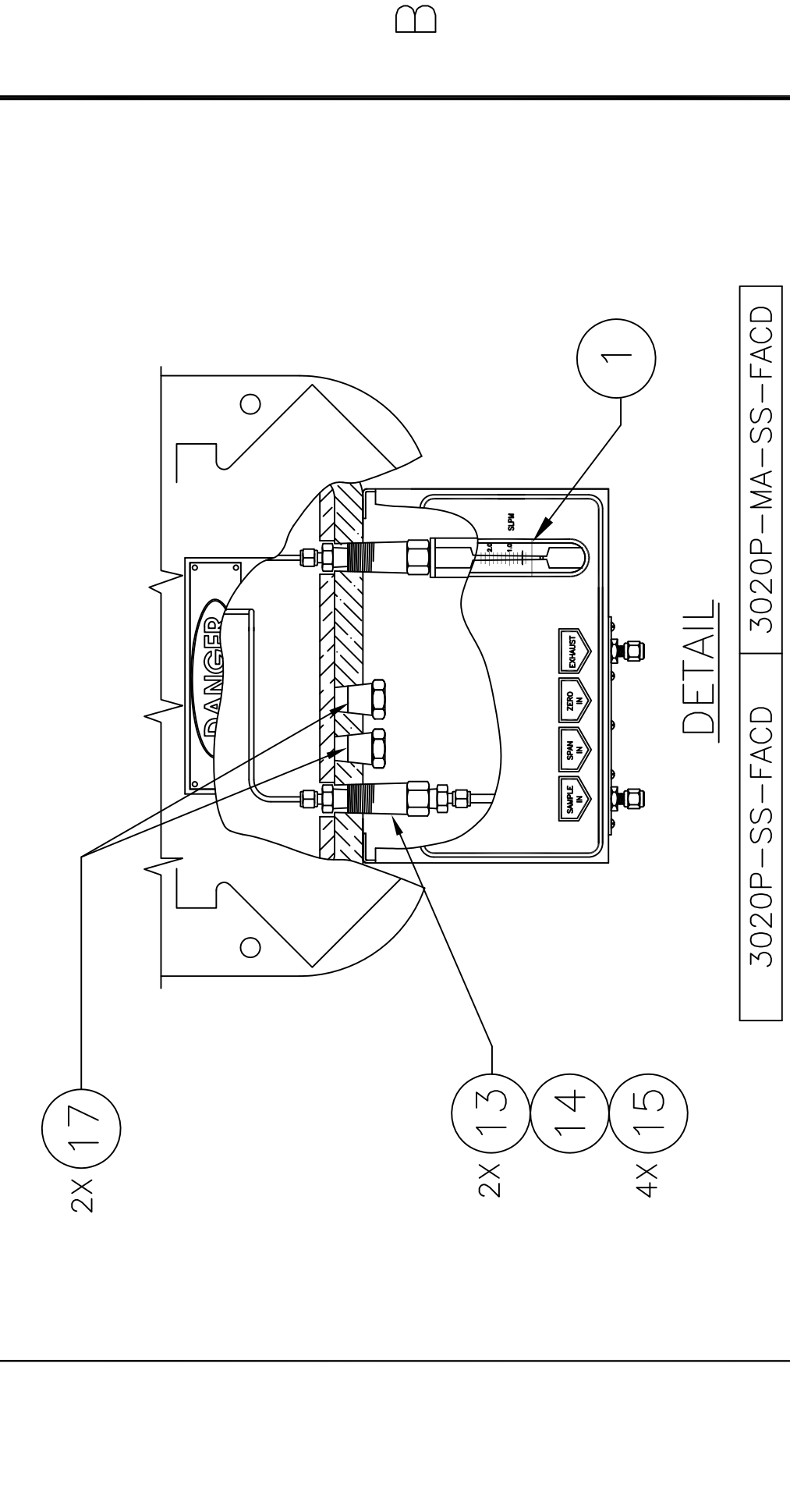
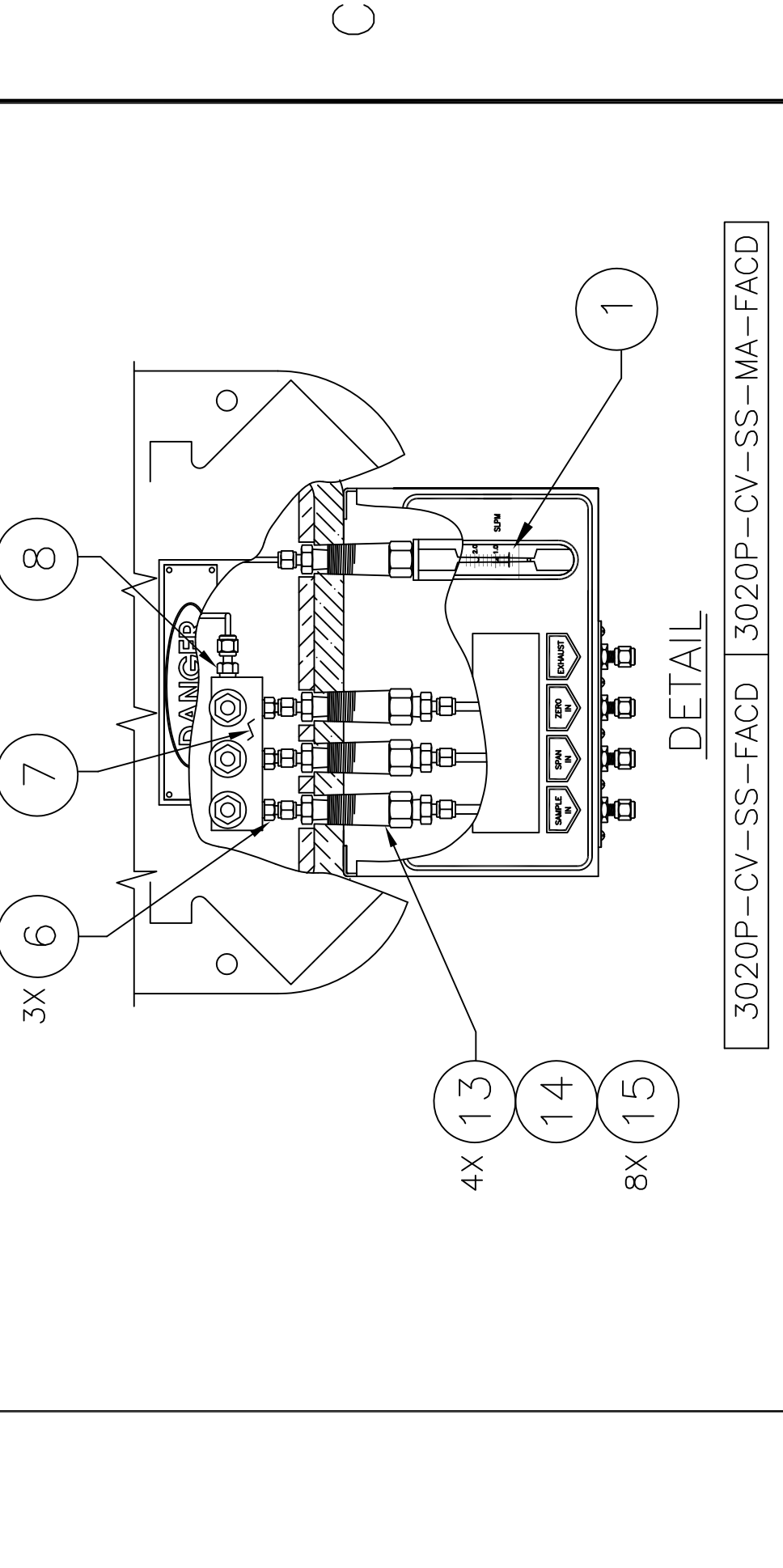
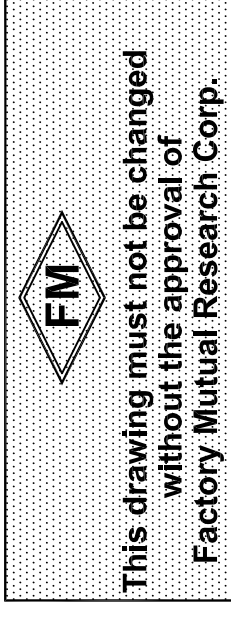

ITEM	QTY	PART NO.	DESCRIPTION
1			PERCENT EDITION STAINLESS STEEL CELL BLOCK SERIES

OPTION ITEM NO.	QUANTITY																				DESCRIPTION				
	A	B	C	D	E	F	G	H	I	J	K	L	M	N	O	P	Q	R	S	T		U	V	W	X
1																									FLOW CONN. FLOWMETER MTC. SUB-ASSY
2																									BOX SUB-ASSEMBLY
3																									DOOR SUB-ASSEMBLY
4																									SCREW, 8-32UNC-2A X 3/8, SS
5																									PLUG MODIFICATION
6																									MALE ADAPTER, 1/8T X 1/8 NPT, SS
7																									FLOW MANIFOLD SUBASSEMBLY
8																									CONNECTOR, 1/8T X 1/8 NPT
9																									FLAME ARRESTOR (FOR GROUP "B,C,D - ADALET")
10																									FLOW CONN. SILK-SCREEN DETAIL
11																									WIRING DIAGRAM
12																									FLAME ARRESTOR (FOR GROUP "C" & "D")
13																									TUBING, SS 1/8"
14																									CONNECTOR, 1/8T X 1/4 NPT, SS
15																									PROGRAMMED EPROM DETAIL
16																									PLUG
17																									ROUTE SHEET
18																									RESTRICTOR KIT
19																									TAG DETAIL
20																									

OPTIONS LIST

ITEM	QTY	PART NO.	DESCRIPTION
BILL OF MATERIAL			
DO NOT SCALE DWG			
THIS DRAWING IS THE PROPERTY OF TELEDYNE ANALYTICAL INSTRUMENTS AND CONTAINS CONFIDENTIAL INFORMATION. IT IS NOT TO BE COPIED, REPRODUCED OR USED WITHOUT WRITTEN PERMISSION.			
TOLERANCE UNLESS OTHERWISE SPECIFIED: ANGULAR ±1/2°			
LINEAR: X = ±.1 XX = ±.01 XXX = ±.005			
SIGNATURES		DATE	
DRFT: BILL TARNIG		11/7/95	
CHK: _____		_____	
APPR: _____		_____	
ENGR: BILL TARNIG 4/9/96		_____	
C.O. _____		_____	
CAD: ID: D66050-12		_____	
REFERENCE		D-66050	
DWG NO.		12	
REV		1	
SHEET		1 OF 1	
SCALE		1/4"	
TITLE		MODEL 3020P OXYGEN ANALYZER FINAL ASSEMBLY	
A business unit of Teledyne Electronic Technologies CITY OF INDUSTRY, CALIFORNIA 91746			

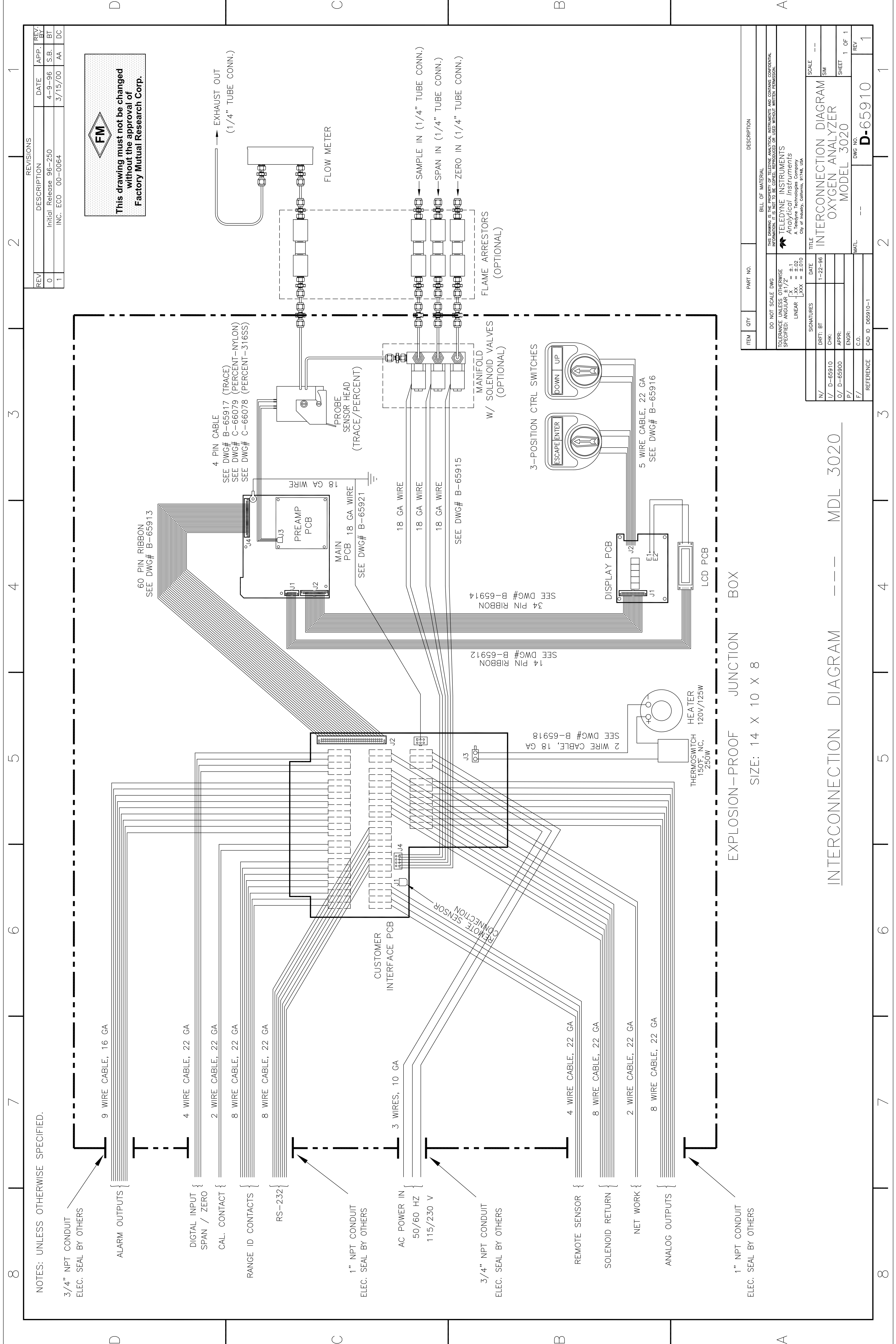

FM

This drawing must not be changed without the approval of Factory Mutual Research Corp.

REV	DESCRIPTION	DATE	APP.	REV.
0	Initial Release 96-250	4-9-96	S.B.	BT
1	INC. ECO 00-0064	3/15/00	AA	DC

ITEM	QTY	PART NO.	DESCRIPTION
BILL OF MATERIAL			
DO NOT SCALE DWG UNLESS OTHERWISE SPECIFIED			
TOLERANCE UNLESS OTHERWISE SPECIFIED			
ANGULAR ±1/2°			
LINEAR ±.010			
HOLE ±.010			
TYPICAL ±.010			
DATE 1-22-96			
SIGNATURES			
N/	DRFT: BT		SCALE ---
I/	D-65910		SIM
O/	D-65900		SHEET 1 OF 1
P/	ENGR:		
F/	C.O.		
REFERENCE	CAD ID: D65910-1		
			DWG NO. D-65910

EXPLOSION-PROOF JUNCTION BOX

SIZE: 14 X 10 X 8

INTERCONNECTION DIAGRAM --- MDL 3020

REV	DESCRIPTION
1	INTERCONNECTION DIAGRAM OXYGEN ANALYZER MODEL 3020

8 7 6 5 4 3 2 1

D C B A

NOTES: UNLESS OTHERWISE SPECIFIED:

3/4" NPT CONDUIT ELEC. SEAL BY OTHERS

ALARM OUTPUTS { 9 WIRE CABLE, 16 GA

DIGITAL INPUT SPAN / ZERO { 4 WIRE CABLE, 22 GA

CAL. CONTACT { 2 WIRE CABLE, 22 GA

RANGE ID CONTACTS { 8 WIRE CABLE, 22 GA

RS-232 { 8 WIRE CABLE, 22 GA

1" NPT CONDUIT ELEC. SEAL BY OTHERS

AC POWER IN { 3 WIRES, 10 GA

50/60 HZ

115/230 V

3/4" NPT CONDUIT ELEC. SEAL BY OTHERS

REMOTE SENSOR { 4 WIRE CABLE, 22 GA

SOLENOID RETURN { 8 WIRE CABLE, 22 GA

NET WORK { 2 WIRE CABLE, 22 GA

ANALOG OUTPUTS { 8 WIRE CABLE, 22 GA

1" NPT CONDUIT ELEC. SEAL BY OTHERS