

Use and Disclosure of Data
Information contained herein is classified as EAR99 under the
U.S. Export Administration Regulations.
Export, reexport or diversion contrary to U.S. law is prohibited.

**INSTRUCTION, OPERATING, AND
MAINTENANCE MANUAL FOR**

MODEL 4020

Standard Software Version



P/N M74661

02/21/18



DANGER



Toxic and/or flammable gases or liquids may be present in this monitoring system.

Personal protective equipment may be required when servicing this instrument.

Hazardous voltages exist on certain components internally which may persist for a time even after the power is turned off and disconnected.

Only authorized personnel should conduct maintenance and/or servicing. Before conducting any maintenance or servicing, consult with authorized supervisor/manager.

EU DECLARATION OF CONFORMITY

APPLICATION OF COUNCIL DIRECTIVE : 2014/30/EU 2014/35/EU(LVD)
RoHS Directive 2011/65/EU, along with Annex IV, item (b) exception

STANDARDS TO WHICH CONFORMITY IS DECLARED : EN61326-1:2013
EN55011 Class A Group 1
EN61000-4-2, EN61000-4-3, EN61000-4-4
EN61000-4-5, EN61000-4-6, EN61000-4-8
EN61000-4-11
EN61010-1:2010 (LVD)

MANUFACTURER'S NAME : TELEDYNE ANALYTICAL INSTRUMENTS

MANUFACTURER'S ADDRESS : 16830 Chestnut Street
City of Industry, CA 91748
U.S.A.

TYPE OF EQUIPMENT : Total Hydrocarbon Analyzer

EQUIPMENT CLASS : Electrical Equipment Measurement,
Control & Laboratory Use - Industrial

MODEL NUMBER : 4020

I, THE UNDERSIGNED, HEREBY DECLARE THAT THE EQUIPMENT SPECIFIED ABOVE CONFORMS TO THE ABOVE DIRECTIVE

SIGNATURE: 

FULL NAME: Angel Alegria

POSITION: New Products Manager

Date: 9-20-17

PLACE: City of Industry, California

Copyright © 2015 Teledyne Analytical Instruments

All Rights Reserved. No part of this manual may be reproduced, transmitted, transcribed, stored in a retrieval system, or translated into any other language or computer language in whole or in part, in any form or by any means, whether it be electronic, mechanical, magnetic, optical, manual, or otherwise, without the prior written consent of Teledyne Analytical Instruments, 16830 Chestnut Street, City of Industry, CA 91748.

Warranty

This equipment is sold subject to the mutual agreement that it is warranted by us free from defects of material and of construction, and that our liability shall be limited to replacing or repairing at our factory (without charge, except for transportation), or at customer plant at our option, any material or construction in which defects become apparent within one year from the date of shipment, except in cases where quotations or acknowledgements provide for a shorter period. Components manufactured by others bear the warranty of their manufacturer. This warranty does not cover defects caused by wear, accident, misuse, neglect or repairs other than those performed by Teledyne or an authorized service center. We assume no liability for direct or indirect damages of any kind and the purchaser by the acceptance of the equipment will assume all liability for any damage which may result from its use or misuse.

We reserve the right to employ any suitable material in the manufacture of our apparatus, and to make any alterations in the dimensions, shape or weight of any parts, in so far as such alterations do not adversely affect our warranty.

Important Notice

This instrument provides measurement readings to its user, and serves as a tool by which valuable data can be gathered. The information provided by the instrument may assist the user in eliminating potential hazards caused by his process; however, it is essential that all personnel involved in the use of the instrument or its interface be properly trained in the process being measured, as well as all instrumentation related to it.

The safety of personnel is ultimately the responsibility of those who control process conditions. While this instrument may be able to provide early warning of imminent danger, it has no control over process conditions, and it can be misused. In particular, any alarm or control systems installed must be tested and understood, both as to how they operate and as to how they can be defeated. Any safeguards required such as locks, labels, or redundancy, must be provided by the user or specifically requested of Teledyne at the time the order is placed.

Therefore, the purchaser must be aware of the hazardous process conditions. The purchaser is responsible for the training of personnel, for providing hazard warning methods and instrumentation per the appropriate standards, and for ensuring that hazard warning devices and instrumentation are maintained and operated properly.

Teledyne Analytical Instruments, the manufacturer of this instrument, cannot accept responsibility for conditions beyond its knowledge and control. No statement expressed or implied by this document or any information disseminated by the manufacturer or its agents, is to be construed as a warranty of adequate safety control under the user's process conditions.

Specific Model Information

The instrument for which this manual was supplied may incorporate one or more options not supplied in the standard instrument. Commonly available options are listed below, with check boxes. Any that are incorporated in the instrument for which this manual is supplied are indicated by a check mark in the box.

Instrument Serial Number: _____

Options Included in the Instrument with the Above Serial Number:

- Power Requirements:** This instrument may be designed for operation using a power source other than 115 VAC @ 60 Hz. If so, one of the boxes below will be checked indicating the power requirements for your instrument.
 - 110 VAC @ 50 Hz
 - 115 VAC @ 50 Hz
 - 220 VAC @ 50/60 Hz
 - Other: _____

- Using Hydrogen as Sample:** For applications where the sample gas is hydrogen, the sample gas doubles as the fuel for combustion. The gas connections made at the back panel are slightly different for this configuration. Connect the hydrogen sample gas to the sample input as usual. Connect a nitrogen source at 15 psig [69 Kpa] to the fuel input. This is discussed in the manual in the Installation section.

- Using Hydrogen as Fuel:** For applications where the fuel is hydrogen, the gas connections made at the back panel are

slightly different. At the “FUEL” inlet, replace the “40% H₂/60% N₂” with pure H₂. This is discussed in the Installation section.

- Special Analysis Ranges:** this model 4020 has special analysis ranges:
Range 1: _____
Range 2: _____
Range 3: _____
- Auto-Calibration Module Option:** This module consists of solenoid for automatically selecting calibration or sample flow to the analyzer and provides the user with the ability to calibrate the analyzer on a user-programmed schedule.
- AP Options:** Vented Sample System Covers; Perforated covers have been installed over the sample system compartment and analyzer top cover for venting purposes.
- Recommended warm-up period:** _____ hours
- Other:**



Safety Messages

Your safety and the safety of others is very important. We have provided many important safety messages in this manual. Please read these messages carefully.

A safety message alerts you to potential hazards that could hurt you or others. Each safety message is associated with a safety alert symbol. These symbols are found in the manual and inside the instrument. The definition of these symbols is described below:



GENERAL WARNING/CAUTION: Refer to the instructions for details on the specific danger. These cautions warn of specific procedures which if not followed could cause bodily Injury and/or damage the instrument.



CAUTION: HOT SURFACE WARNING: This warning is specific to heated components within the instrument. Failure to heed the warning could result in serious burns to skin and underlying tissue.



WARNING: ELECTRICAL SHOCK HAZARD: Dangerous voltages appear within this instrument. This warning is specific to an electrical hazard existing at or nearby the component or procedure under discussion. Failure to heed this warning could result in injury and/or death from electrocution.



Technician Symbol: All operations marked with this symbol are to be performed by qualified maintenance personnel only.

No
Symbol

NOTE: Additional information and comments regarding a specific component or procedure are highlighted in the form of a note.



STAND-BY: This symbol indicates that the instrument is on Stand-by but circuits are active.

CAUTION: THE ANALYZER SHOULD ONLY BE USED FOR THE PURPOSE AND IN THE MANNER DESCRIBED IN THIS MANUAL.



IF YOU USE THE ANALYZER IN A MANNER OTHER THAN THAT FOR WHICH IT WAS INTENDED, UNPREDICTABLE BEHAVIOR COULD RESULT POSSIBLY ACCOMPANIED WITH HAZARDOUS CONSEQUENCES.

This manual provides information designed to guide you through the installation, calibration and operation of your new analyzer. Please read this manual and keep it available.

Occasionally, some instruments are customized for a particular application or features and/or options added per customer requests. Please check the front of this manual for any additional information in the form of an Addendum which discusses specific information, procedures, cautions and warnings that may be specific to your instrument.

Manuals do get misplaced. Additional manuals can be obtained from Teledyne at the address given in the Appendix. Some of our manuals are available in electronic form via the internet. Please visit our website at: www.teledyne-ai.com.

Table of Contents

Safety Messages	v#
List of Figures.....	xi#
List of Tables	xii#
Additional Safety Information	xiii#
Procedure for Removal of Internal Inaccessible Shock Hazards	xv#
Introduction	1#
1.1 Main Features of the Analyzer	1#
1.2 Principle of Operation	2#
1.3 Analyzer Description	2#
1.4 Applications	3#
Operational Theory	7#
2.1 Introduction	7#
2.2 Sample System	7#
2.2.1 Input Porting	8#
2.2.2 Sample Flow Control System	8#
2.2.3 Fuel and Blanket Air Systems	8#
2.2.4 Flame Ionization Detection Cell	9#
2.3 Detection Cell	9#
2.3.1 Electrometer-Amplifier	10#
2.3.2 Anode Power Supply	11#
2.3.3 Flame Guard Circuit	11#
2.3.4 Flame Ignition Circuit	11#
2.3.5 Proportional Temperature Control Circuit	11#
Installation	13#
3.1 Unpacking the Analyzer	13#

3.2 Mounting the Analyzer	13#
3.3 User Connections	14#
3.3.1 Electrical Power Connections	14#
3.3.2 Gas Connections	14#
3.3.2.1 Vent Connections	15#
3.3.3 Electrical Connections	16#
3.3.3.1 Primary Input Power	17#
3.3.3.2 Fuse Installation	17#
3.3.3.3 50-Pin Equipment Interface Connector	17#
3.3.3.4 Analog Output	17#
3.3.3.5 Alarm Relays	20#
3.3.3.6 Digital Remote Cal Inputs	21#
3.3.3.7 Range ID Relays	22#
3.3.3.8 Network I/O	23#
3.3.3.9 Pin Out Table	23#
3.3.4 RS-232 Port	25#
3.3.5 Supporting Gases	26#
3.3.5.1 Sample Gas	27#
3.3.5.2 Effluent	27#
3.3.5.3 Sample Bypass Vent	27#
3.3.5.4 Fuel and Air Connections	27#
Operation	29#
4.1 Equipment	29#
4.2 Preliminary Power-Off Check List	30#
4.3 Placing the System in Operation	30#
4.4 Activating the Support Gases	31#
4.4.1 Air	31#
4.4.2 Sample Gas	31#
4.4.3 Span Gas	31#
4.4.4 Fuel	31#



Total Hydrocarbon Analyzer

4.5 Flame Ignition	32#
4.5.1 Verification of the Flame Guard Circuit	32#
4.5.2 Ignition and/or Flame Guard Circuit Failure	33#
4.6 Analyzer Operation	33#
4.6.1 Default Parameters	34#
4.6.2 Style Conventions	34#
4.6.3 Using the Controls	35#
4.6.4 Mode/Function Selection	35#
4.6.4.1 Analysis Mode	36#
4.6.4.2 Setup Mode	37#
4.6.5 Data Entry	38#
4.6.5.1 ENTER	38#
4.6.5.2 ESCAPE	38#
4.6.6 Setting up an AUTO-CAL	40#
4.6.7 Password Protection	42#
4.6.7.1 Entering the Password	43#
4.6.7.2 Installing or Changing the Password	44#
4.6.8 Logging Out	45#
4.6.9 System Self-Diagnostic Test	45#
4.6.10 The Model Screen	46#
4.6.11 Calibration Options	47#
4.6.12 Zero and Span Functions	48#
4.6.13 The Alarms Function	52#
4.6.14 The Range Function	55#
4.6.14.1 Manual (Select/Define Range) Screen	56#
4.6.14.2 Auto Range	57#
4.6.14.3 Digital Mode	58#
4.6.15 Digital Filter Setup	59#
4.6.16 Fuel Display	60#
4.6.17 Valve Selections	60#

4.6.17.1 Disabled	61#
4.6.17.2 User Select	62#
4.6.17.3 Default (By Function)	63#
4.6.17.4 Observing the gas Stream Concentrations	64#
4.6.18 Standby	65#
4.7 Advanced User Functions	66#
4.7.1 Zero Offset Adjustment	66#
4.7.2 Background Gas Selection	67#
Maintenance & Troubleshooting	69#
5.1 Measuring Circuit Electrical Checks	70#
5.1.1 Loss of Zero Control	70#
5.1.2 Anode Voltage Check	71#
5.1.3 Electronic Stability	72#
5.1.4 Printed Circuit Board Replacement	72#
5.1.5 Collector Cable	72#
5.2 Temperature Control Electronic Check	73#
5.3 Ignition and/or Flame Guard Circuit Checks	74#
5.4 Sampling System	75#
5.5 Printed Circuit Board Descriptions	75#
5.5.1 Flame Guard and Anode Power Supply PCB	75#
5.5.3 Proportional Temperature Controller PCB	76#
5.5.4 Electrometer-Amplifier PCB	78#
Appendix	81#
Specifications	81#
Application Data	82#
Recommended Spare Parts List	83#
Drawing List	84#

List of Figures

Figure 1-1: Gas Sample System with Optional AutoCal Valves	4#
Figure 1-2: Gas Sample System Without Optional AutoCal Valves.	5#
Figure 1-3: Flame Ionization Cell.....	6#
Figure 2-1: View Inside Cabinet	10#
Figure 3-1: Gas Connections.....	15#
Figure 3-2: Equipment Interface Connector Pin Arrangement.....	17#
Figure 4-1: Front Panel View of Regulator and Gages	32#
Figure 4-2: Typical VFD Screen Layout	35#
Figure 4-3: Setup Mode Functions	39#
Figure 4-4: AUTOCAL Screens.....	42#

List of Tables

Table 3-1: Analog Output Connections	18
Table 3-2: Analog Concentration Output—Example	19
Table 3-3: Analog Range ID Output—Example.....	19
Table 3-4: Alarm Relay Contact Pins	20
Table 3-5: Remote Calibration Connections.....	21
Table 3-6: Range ID Relay Connections	23
Table 3-7: Pin out of 50 pin D-Sub Connector.....	23
Table 3-8: Commands via RS-232 Input	26
Table 3-9: Required RS-232 Options	26
Table 4-1: Digital Range Selection Signals	58

Additional Safety Information

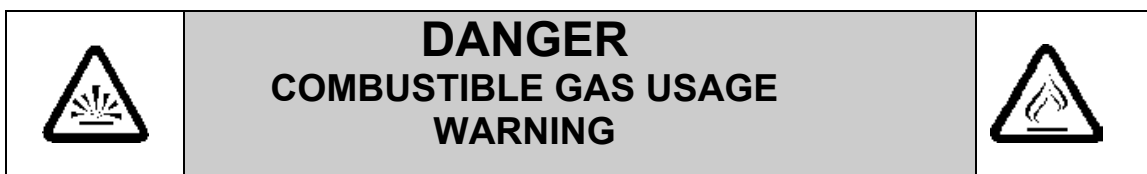

This is a general purpose instrument designed for usage in a non-hazardous area. It is the customer's responsibility to ensure safety especially when combustible gases are being analyzed since the potential of gas leaks always exist.

The customer should ensure that the principles of operating of this equipment are well understood by the user. Misuse of this product in any manner, tampering with its components, or unauthorized substitution of any component may adversely affect the safety of this instrument.

Since the use of this instrument is beyond the control of Teledyne, no responsibility by Teledyne, its affiliates, and agents for damage or injury from misuse or neglect of this equipment is implied or assumed.



WARNING: *HYDROGEN GAS IS USED IN THIS INSTRUMENT AS A FUEL. HYDROGEN IS EXTREMELY FLAMMABLE. EXTREME CARE MUST BE USED WHEN WORKING AROUND GAS MIXTURES CONTAINING FLAMMABLE GASES.*

A Successful leak check was performed at TI/AI on the sample system of this instrument prior to calibration, testing and shipping. Ensure that there are no leaks in the fuel supply lines before applying power to the system.

Always purge the entire system before performing any maintenance and always leak check the system after removing any tubing or fittings on the sample system. See the procedures for purging and leak checking this instrument on the following pages.

If toxic gases or other hazardous materials are introduced into the sample system, the same precautions regarding leak checking and purging apply to the sample lines and sample supply or delivery lines.

WARNING:



ELECTRICAL SHOCK HAZARD. WITH THE EXCEPTION OF OPENING THE DOOR AND ADJUSTING THE PRESSURE REGULATORS, FLOW CONTROLLER, OR OBSERVING THE PRESSURE GAUGES AND THE FLOWMETER, ONLY AUTHORIZED AND SUITABLY TRAINED PERSONNEL SHOULD PERFORM WORK INSIDE OF THE INSTRUMENT. COMPONENTS WITHIN THE COVER ON THE INSIDE OF THE DOOR, INSIDE THE ISOTHERMAL CHAMBER (SAMPLE SYSTEM), AND ON THE ELECTROMETER-AMPLIFIER PC BOARD CONTAIN DANGEROUSLY HIGH VOLTAGE SUFFICIENT TO CAUSE SERIOUS INJURY OR DEATH.

There are the following three types of inaccessible shock hazards within the 4020:

1. *Line voltages and line related voltages such as 115 VAC which exists within the 230 VAC version as well. These voltages stop when the 4020 is turned off and the mains (line) cord is removed from the instrument.*
2. *The sensor anode supply voltage (approximately 250 VDC). This voltage exists on the Flame Guard, anode power supply, PCB, the motherboard, and the anode/igniter terminals on the sensor. THIS VOLTAGE WILL REMAIN HAZARDOUS FOR MANY MINUTES AFTER THE MODEL 4020 HAS BEEN TURNED OFF!*

3. *External hazardous voltages which may be connected to the Model 4020 alarm relay connections.*

Procedure for Removal of Internal Inaccessible Shock Hazards



CAUTION: SERVICING OR MAINTENANCE OF THE 4020 SHOULD ONLY BE DONE BY SUITABLE TRAINED PERSONNEL. TO AVOID THESE INACCESSIBLE HAZARDOUS VOLTAGES WHEN SERVICING THE 4020, PERFORM EACH OF THE FOLLOWING STEPS, IN THE ORDER GIVEN, BEFORE SERVICING BEGINS:

1. Switch off the power to the 4020 and remove the mains (line) power cord from the 4020.
2. Remove all external voltages from the connections to the alarm contacts.
3. Wait one minute.
4. Discharge the anode supply voltage.
 - a. Connect one end of an insulated (to 1000 VDC or more) clip lead to 4020 chassis ground (the standoff for the upper right corner of the mother PCB).
 - b. Put one end of a 500V rated 1000 ohm resistor in the other end of the clip lead.
 - c. Check the voltage between chassis ground (the standoff for the upper right corner of the mother PCB) and the top side of R2 at PCB number B74671. It should be between -5VDC and +5VDC. If is in that range, the inaccessible hazardous voltage removal procedure is completed, if not repeat steps 4.a and 4.b.

If it is absolutely necessary to work inside the instrument with power on, use the ONE HAND RULE:

Work with one hand only.

Keep the other hand free without contacting any other object. This reduces the possibility of a ground path through the body in case of accidental contact with hazardous voltages.

WARNING:



THIS INSTRUMENT IS DESIGNED TO BE OPERATED IN A NONHAZARDOUS AREA. THE ANALYZER USES HYDROGEN GAS AND/OR OTHER COMBUSTIBLE GASES IN ITS OPERATION. THIS EQUIPMENT, IF NOT USED AND MAINTAINED PROPERLY CAN BE AN EXPLOSION HAZARD. THE ANALYZER, DEPENDING ON THE APPLICATION, MAY ALSO USE TOXIC GASES. IT IS THEREFORE, THE CUSTOMER'S RESPONSIBILITY TO ENSURE THAT PROPER TRAINING AND UNDERSTANDING OF THE PRINCIPLES OF OPERATION OF THIS EQUIPMENT ARE UNDERSTOOD BY THE USER. SINCE THE USE OF THIS INSTRUMENT IS BEYOND THE CONTROL OF TELEDYNE, NO RESPONSIBILITY BY TELEDYNE, ITS AFFILIATES AND AGENTS FOR DAMAGE OR INJURY RESULTING FROM MISUSE OR NEGLIGENCE OF THIS INSTRUMENT IS IMPLIED OR ASSUMED. MISUSE OF THIS PRODUCT IN ANY MANNER, TAMPERING WITH ITS COMPONENTS OR UNAUTHORIZED SUBSTITUTION OF ANY COMPONENT MAY ADVERSELY AFFECT THE SAFETY OF THIS INSTRUMENT.

CAUTION:



WHEN OPERATING THIS INSTRUMENT, THE DOORS MUST BE CLOSED AND ALL COVERS SECURELY FASTENED. THE GAUGES MUST BE IN PROPER WORKING ORDER. DO NOT OVERPRESSURIZE THE SYSTEM.

READ THIS MANUAL BEFORE OPERATING THE INSTRUMENT AND ADHERE TO ALL WARNINGS INCLUDED IN THIS MANUAL.

Introduction

Teledyne Analytical Instruments Model 4020 Total Hydrocarbon Analyzer is a versatile instrument designed to measure the quantity of hydrocarbons present in a positive pressure sample as equivalent methane. The Model 4020 is a microprocessor controlled digital instrument based on Teledyne's highly successful Model 402R series analog Total Hydrocarbon Analyzer.

1.1 Main Features of the Analyzer

The Model 4020 Total Hydrocarbon Analyzer is sophisticated yet simple to use. A dual display on the front panel prompts and informs the operator during all phases of operation. The main features of the analyzer include:

- Easy-to-use front panel interface that includes a red 5-digit LED display and a vacuum fluorescent display (VFD), driven by microprocessor electronics.
- High resolution, accurate readings of concentration from low ppm levels to 6%.
- Microprocessor based electronics: 8-bit CMOS microprocessor with 32 kB RAM and 128 kB ROM.
- Versatile analysis with three user-definable analysis ranges from 1 ppm through 6%.
- Autoranging allows analyzer to automatically select the proper preset range for a given measurement. Manual override allows the user to lock onto a specific range of interest.
- A digital mode for range selection allows the user to perform range switching using the remote calibration contacts.
- O₂/N₂ background gas selection allows the use of two different sample background gases with separate calibration parameters stored in memory.

- Two adjustable concentration alarms and a system failure alarm.
- Extensive self-diagnostic testing at startup and on demand with continuous power supply monitoring.
- RS-232 serial digital port for use with a computer or other digital communication device.
- Analog outputs for concentration and range identification (0-1 VDC standard and isolated 4-20 mA dc).
- Superior Accuracy

1.2 Principle of Operation

The sample gas is mixed with a fuel (normally a composition of hydrogen and nitrogen) and burned in an atmosphere of “blanket air”. The ions formed in the burning process cause an electrical conduction between two electrodes in the combustion chamber (or detector cell) that is amplified by a highly sensitive electrometer-amplifier circuit. The electrical output of the electrometer-amplifier is directly proportional to the quantity of flame ionizable hydrocarbons present, and is linear over the range of 0-60,000 PPM methane.

1.3 Analyzer Description

The information contained in this manual describes individual analyzers of the Model 4020 standard series. The versatility of this analyzer is inherited through the long heritage of the earlier analog unit. Very often, special customer driven design features are incorporated and will require additional or supplementary information in addition to the information described in this manual. These special considerations, if applicable, will be described in detail on specific application pages as Addenda to this manual. When the Model 4020 is a part of a larger system, it is subordinate to that system, and specific installation and operation conditions of that system will apply. Consult system sections of the manuals for those applications, where conditions specific to those systems will be detailed.

To best suit the needs of the purchaser, specialized designs may have been adopted. Details of the design differences may be found in the various drawings (outline, assembly, schematic, wiring, and piping diagrams) in the drawings section at the rear of the manual.



The standard analyzer is housed in a sheet steel equipment case flush-mounted in a 19" rack. The front interface panel is mounted on a door which, when opened, allows convenient access to the 4020 electronics. The entire front panel can slide out of the chassis to provide greater access to the electronics and to the sample system. Gas pressure and flow controls are mounted on the front panel adjacent to the LED and VFD displays and user interface.

At the rear of the instrument are ports for the introduction of air, fuel, zero, span, and sample gas. A single 50-pin user-interface cable connector contains input/output and alarm signals available to the user. An RS-232 port is also available at the rear panel for connection to a remote computer or other digital communication device. The Model 4020 is set up for either 120 VAC 60 Hz or 230 50/60 Hz operation depending on the customer's requirements. The appropriate power cord for your unit has been shipped with this instrument.

1.4 Applications

- Monitoring the purity of oxygen, argon, nitrogen and other gases in the manufacture of semiconductors and related equipment.
- Monitoring hydrocarbon contamination in air liquefaction and other gas production processes.
- Gas purity certification.
- Detecting trace hydrocarbons in ambient air.
- Detecting atmospheric pollutants.
- Cryogenics.
- Monitoring for fuel leakage or toxic solvents.
- Monitoring hydrocarbons in a wide range of process streams.

Sample Gas Other Than Hydrogen

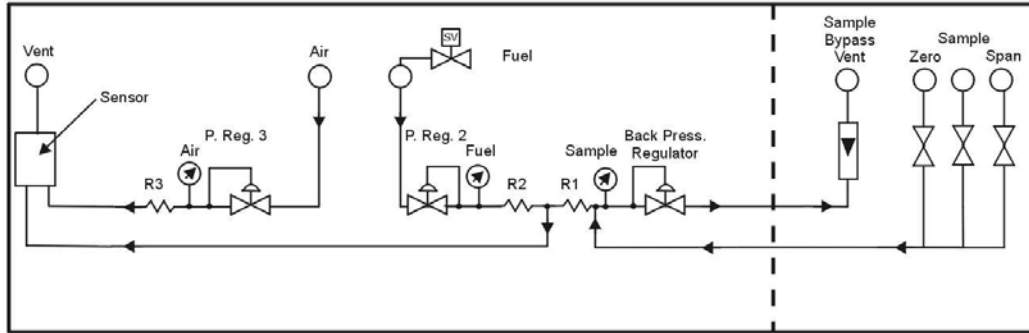

Hydrogen as Sample Gas

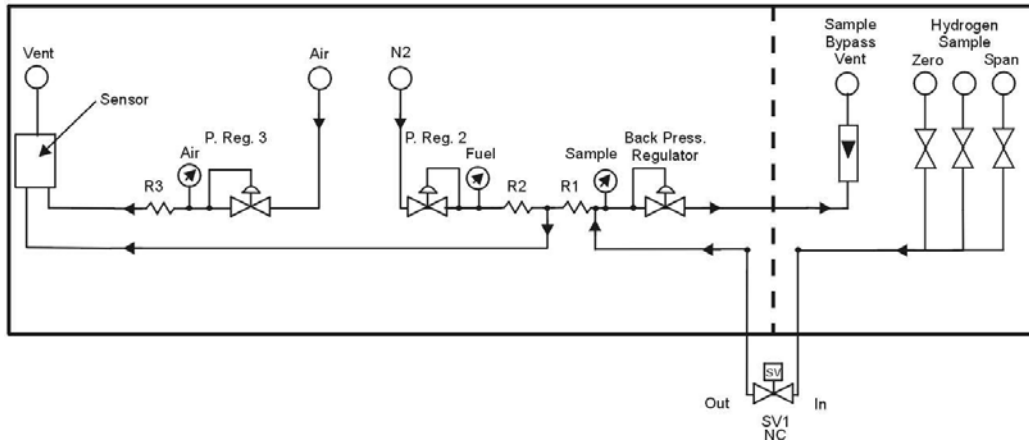
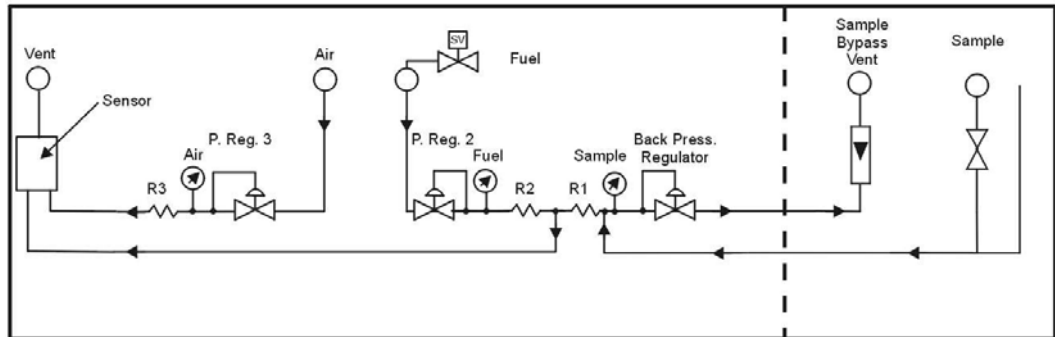

Figure 1-1: Gas Sample System with Optional AutoCal Valves

Sample Gas Other Than Hydrogen



Hydrogen as Sample Gas

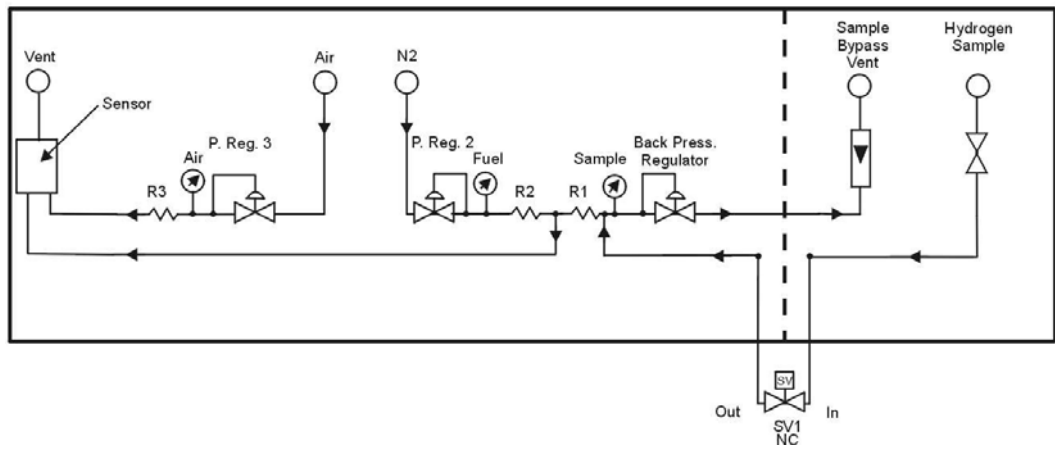

Figure 1-2: Gas Sample System Without Optional AutoCal Valves

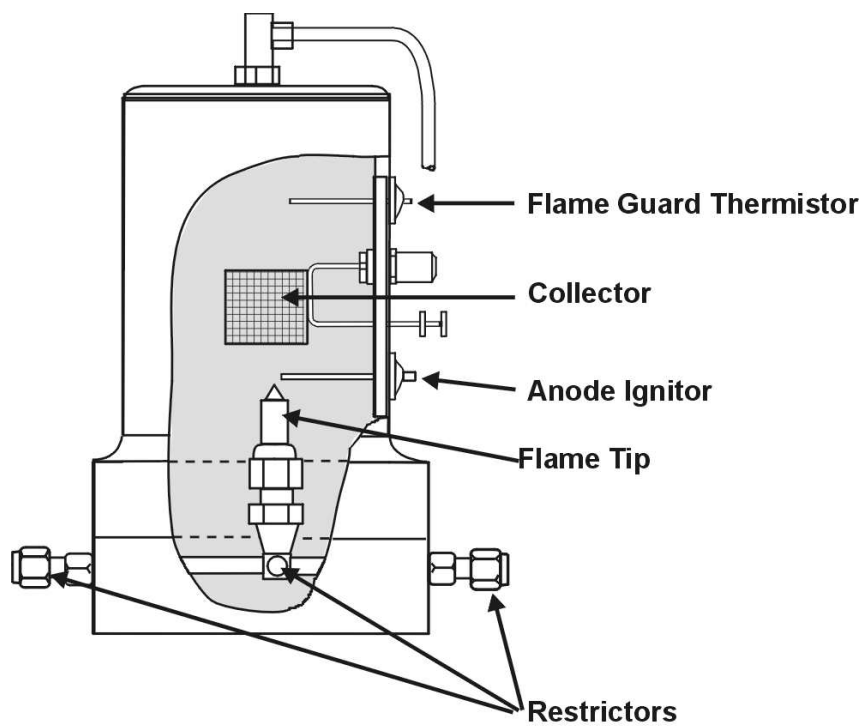

Figure 1-3: Flame Ionization Cell

Operational Theory

2.1 Introduction

The Model 4020 Total Hydrocarbon Analyzer is composed of three subsystems:

1. Sample System
2. Detector Cell
3. Electronic Signal Processing, Display and Control

2.2 Sample System

Note: The measured component for the Model 4020 is hydrocarbon content. Hydrocarbon lubricants and conditioners, as well as synthetic plastics are common to instrumentation supply processes. Utmost precaution must be taken at all times to specify hydrocarbon-free gases, regulator diaphragms, and supplies.

All components used to control the sample and supporting gases, as well as the combustion portion of the detector cell, are located inside the enclosure, behind the electronics control panel and are accessible by sliding the front of the unit out from the rack enclosure. Adjustments are made using the appropriate control on the front panel.

The software in the Model 4020 allows the system to be used for analyzing a sample gas in two different backgrounds, O₂ and N₂. A separate calibration must be performed on each sample/background combination. The calibration parameters are stored internally and are appropriately applied when the user selects the specific background gas in use. See Section 4.7.2 Background Gas Selection.

Note: The user must supply the necessary valves and any associated switching equipment for delivering the correct sample/background gas combination to the analyzer.

The basic analyzer consists of an isothermal chamber containing the pressure regulators, pressure gauges and flow restrictors. The temperature within the chamber is maintained at 125°F by a heating element. The regulated temperature of the chamber insures stable gas flow. An optional AutoCal module is available which when fitted, mounts inside the instrument enclosure and integrates with the sample system. It allows convenient switching between sample and calibration gases. When installed, it is part of the isothermal chamber. The bypass flow is also controlled from this optional panel.

2.2.1 Input Porting

The analyzer is equipped with ports for the introduction of air, fuel, zero, span, and sample gas.

2.2.2 Sample Flow Control System

Stable sample flow is achieved by maintaining a constant pressure across a restrictor through the use of a back-pressure regulation system, which includes an adjustable regulator, pressure gauge, throttle valve, and flowmeter. The throttle valve and flowmeter are included so that the bypass flow required by the back-pressure regulator can be limited. Without these controls, a high sample point pressure would result in unnecessary sample waste through the back-pressure regulator.

The components of the system are arranged so that no dead volume is present in the sample path to the detector cell. This guarantees rapid response to changes in hydrocarbon concentration—a fact that can be demonstrated when zero and span gas are exchanged during the standardization procedure.

The restrictors used in the system look alike; however, they are not interchangeable.

2.2.3 Fuel and Blanket Air Systems

The fuel and blanket air systems use similar components. Stable flow is achieved by maintaining a constant pressure across restrictors upstream from the cell. Each system incorporates an adjustable pressure regulator, pressure gauge, and restrictor. A flame out light is included to indicate when the flame fails. A fuel shut-off solenoid valve, mounted on the line that supplies fuel, stops the fuel flow in case of flame failure. This valve is located in line with the fuel port; except for instruments using hydrogen as the sample gas. In this case, the sample is used as fuel and the valve is

located in line with the sample port. See Figure 1-1 for a flow schematic for instruments equipped with AutoCal valves and Figure 1-2 for instruments without the AutoCal option.

2.2.4 Flame Ionization Detection Cell

The sample and fuel are combined within a tee fitting located in the isothermal chamber. The mixed gas is emitted from a burner within the sensor assembly. Blanket air is introduced into the sensor (or cell) by means of a separate fitting that is located in the base section of the assembly. The upper half of the assembly houses the anode-igniter, collector, and flame guard thermistor. The cell is located at the left hand front area inside the enclosure for easy access. See Figure 2.1.

2.3 Detection Cell

The upper section of the stainless steel flame ionization cell houses the cylindrical collector electrode, the high voltage (+260 VDC) anode-igniter coil, and the sensing thermistor of the flame guard circuit (see cell cross-section Figure 1-3).

WARNING: ***DANGEROUS HIGH VOLTAGE EXISTS AT THE ANODE IGNITER COIL (+260 VDC). DO NOT ATTEMPT TO DISCONNECT THE IGNITER COIL CABLE OR DISASSEMBLE ANY OF THE FLAME IONIZATION CELL COMPONENTS WITHOUT TURNING OFF THE POWER AND DISCONNECTING THE POWER CORD.***



The collector is interconnected with the electrometer-amplifier PC board by a coaxial cable. Although the cable and fittings are intended for coaxial service, the cable is actually being used as a shielded single-conductor connection.

The anode-igniter, as its name implies, serves two functions. When relay K2 at PCB part number B74671 is energized, the coil becomes an electrical heating element that glows red-hot and ignites the hydrogen fuel. When relay K2 at B74671 is de-energized, the coil is connected to the +260 volt DC terminal of the anode-flame guard power supply PC board. In this configuration, the necessary potential difference is established between the coil (anode) and collector to promote ionization of the burned hydrocarbons. The coil functions as the high voltage anode in all three range positions of the selector switch.

The thermistor acts as the sensor in the flame guard circuit. Its ambient temperature resistance is in the 100 K ohms region. When the flame is ignited, its resistance is reduced by a factor of 100. The thermistor is coupled to a semiconductor control circuit on the anode-flame guard power supply PC board, which will be described in a following section.

The cell electrodes of both the anode-igniter and flame guard thermistor are connected to the electronics chassis by means of a plug-in cable.

The electrode section of the cell may be removed for inspection by turning off the power, disconnecting the electrode lead plug, and removing the screws which retain the electrode assembly in the sensor body.

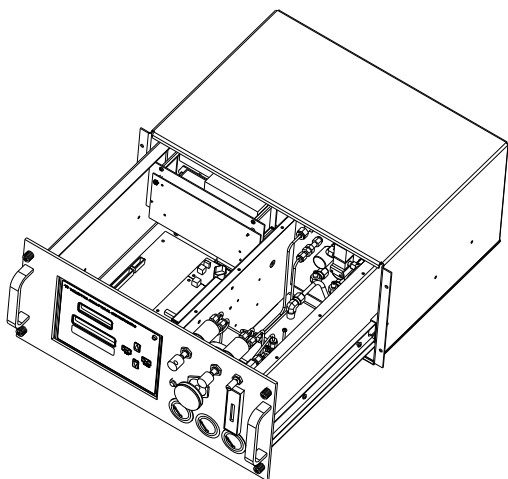

Figure 2-1: View Inside Cabinet

2.3.1 Electrometer-Amplifier

The collector cable is coupled directly to a coaxial fitting located on the electrometer-amplifier PC board. The PC board is located on the side panel next to but outside of the isothermal chamber. See Figure 2-1. and consists of an electrometer amplifier and an operational amplifier. This circuit is a very high-gain, current-to-voltage converter circuit, having

an input impedance measuring in the billions of ohms. It is static sensitive and highly susceptible to contamination. Special care must be taken in handling this PC board.

Refer to Section 5.5.4: *Electrometer-Amplifier PC Board* for more information concerning the electrometer-amplifier and the other printed circuits that follow.

2.3.2 Anode Power Supply

The high voltage anode power supply components are mounted on the anode power supply printed circuit board. High voltage regulation is achieved through the use of series-connected zener diodes. The simplicity of this circuit's design can be attributed to the extremely low current demand of the anode circuit. The positive output voltage is nominally 125 volts. Output tolerance is ± 10 volts from the specified 125 volts.

2.3.3 Flame Guard Circuit

A thermistor-controlled, transistorized switching circuit is employed to operate a relay in the event of a flame-out condition. A panel indicator light and fuel shut-off solenoid valve are operated by the relay to alarm personnel that a flame-out condition has occurred. The fuel shut-off solenoid valve stops the hydrogen flow.

2.3.4 Flame Ignition Circuit

The flame ignition circuit includes the anode-igniter electrode (in the detector cell), a transformer, and processor controlled relay. The circuit is automatically energized after the warm up count down timer expires.

If automatic ignition fails, there will be a message that reports this, and the flame can be manually ignited by pressing simultaneously the Up and Down key.

2.3.5 Proportional Temperature Control Circuit

The temperature of the isothermal chamber containing the sampling components is regulated by a thermistor-directed electronic circuit. The thermistor and heating element are located in the chamber, and the balance of the circuit components are mounted on the temperature controller printed circuit board. A temperature limit switch protects the

isothermal chamber against excessive temperature, which may occur if the temperature controlling system fails.

Installation

Installation of the Model 4020 Total Hydrocarbon Analyzer includes:

1. Unpacking
2. Mounting
3. Gas connections
4. Electrical connections
5. Testing the system.

3.1 Unpacking the Analyzer

Although the analyzer is shipped with all the materials you need to install and prepare the system for operation. Carefully unpack the analyzer and inspect it for damage. Immediately report any damage or shortages to the shipping agent.

3.2 Mounting the Analyzer

The Model 4020 is a general-purpose analyzer and as such is designed with (non-sealed) enclosures. It must be installed in an area where the ambient temperature is not permitted to drop below 32°F nor rise above 100°F. In areas outside these temperatures, auxiliary heating/cooling must be supplied. The 4020 enclosure is oil and dust resistant and although it is designed to resist moisture, it should NOT be considered completely watertight. Mounting to walls or racks must be made securely. Avoid locations that are subject to extreme vibration and sway.

Sufficient space must be provided around the analyzer to accommodate the necessary electrical conduit and plumbing connections. The front panel must be allowed to be pulled out for possible service access to all components of the enclosure. Refer to the system/analyzer outline drawings for dimensions.

Note: To completely slide the analyzer out of the enclosure, pull analyzer out until it stops, then push down on the release levers found almost at the end of the sliders, both sides at the same time.

Regardless of configuration, the analyzer/system must be installed on a level surface with sufficient space allocated on either side for personnel and test equipment access. Subject to the foregoing, the analyzer/system should be placed as close to the sample point as is possible.

All pertinent dimensions, connecting points, and piping details can be found in the drawings section as part of the outline, input-output, and piping diagrams. These drawings are specific to the instrument or system to which the manual applies.

3.3 User Connections

All user connections are made on the rear panel. Consult the input-output and outline diagrams in the drawing section of the manual. Not all the features displayed may be present in your system. Refer to any Addenda for additional information that may apply to your instrument.

3.3.1 Electrical Power Connections

The standard analyzer requires a supply of 100-125VAC, single-phase power. Power connections are made at the rear panel of the unit. Refer to the input-output diagram for more information. The electrical power service must include a high-quality ground wire. A high-quality ground wire is a wire that has zero potential difference when measured to the power line neutral. If you have the 220 VAC option, you will require 220 or 240 VAC, 50/60 Hz power. Check the analyzer input-output diagram, power schematic, outline, and wiring diagrams for incoming power specifications and connecting points.

CAUTION: **PRIMARY POWER TO THE SYSTEM SHOULD NOT BE SUPPLIED UNTIL ALL CUSTOMER WIRING IS INSPECTED PROPERLY BY START-UP PERSONNEL.**



3.3.2 Gas Connections

The analyzer gas connection diagram identifies the various gas connection points as to function and location. Figure 3-1 shows the gas connection points for instruments with the optional AutoCal module.

Figure 3-1: Gas Connections

Gas connections to the instrument are made at the 1/8" or 1/4" stainless steel tube fittings provided on the rear panel. Note that the Purge and Sensor Vent fittings are 1/4" while all other gas connections are 1/8".

It is recommended that all gas tubing leading to the connections on the back of the analyzer be of the coiled type. This will facilitate sliding the unit out of the case without disconnecting the gas supply to the analyzer.

Before tubing is connected to the system, it must be decontaminated to rid it of hydrocarbon deposits. Using a small torch, heat each length of tubing, while passing nitrogen through it, until it glows red. Begin at the nitrogen source end and proceed down the length of the tube, "chasing" the red glow (and hydrocarbon deposits) down to the open end of the tube. Cap tubing while not in use with suitable non-contaminating caps.

All sample, calibration, and supporting gas lines which deliver gas to the analyzer must be decontaminated before connection; vent lines do not.

When connecting the various gas lines to the system, be absolutely certain that no "dead ends" are left; that is, no unused branch lines should be left capped off, where pockets might form of material that is not representative of the current contents of the line, or which might keep contaminants from being purged out of the system.

Note: If different background gases are being used, the user must supply the necessary valves and any associated switching equipment for delivering the correct sample/background gas combination to the analyzer.

3.3.2.1 VENT CONNECTIONS

Two separate vent connections may be required on your instrument:

- Sensor Vent
- Bypass Vent

Sensor vent and sample bypass vent must run separately.

The sample and bypass vent lines should not be tied together outside of the system enclosure and the lines need to be installed at a downward sloping angle to prevent a potential build-up of condensing water vapor in the vent lines. Follow the installation guidelines below.

Sensor Vent:

All the gases introduced into the detection cell are vented from a single fitting labeled SENSOR VENT at the rear of the analyzer.

1. TAI recommends that the cell be permitted to vent directly to atmosphere wherever possible.
2. If the vent line is required, the installation must include a drop-out pot to collect any water that is formed by the burning of the hydrogen fuel.
3. The vent line must be constructed so that the water and dirt cannot collect in it.
4. Sensor vent line must slope downward so condensed water will freely drain.

SAMPLE BYPASS VENT:

The sample bypassed by the back-pressure regulation system vents from a separate port labeled BYPASS VENT at the rear of the analyzer.

If this vent is required, it must be installed so that water and dirt cannot accumulate in it.

3.3.3 Electrical Connections

Figure 3-1 shows the Model 4020 rear panel. There are connections for power, digital communications, and both digital and analog concentration output.

For safe connections, no uninsulated wiring should be able to come in contact with fingers, tools or clothing during normal operation.

CAUTION:



USE SHIELDED CABLES. ALSO, USE PLUGS THAT PROVIDE EXCELLENT EMI/RFI PROTECTION. THE PLUG CASE MUST BE CONNECTED TO THE CABLE SHIELD, AND IT MUST BE TIGHTLY FASTENED TO THE ANALYZER WITH ITS FASTENING SCREWS. ULTIMATELY, IT IS THE INSTALLER WHO ENSURES



THAT THE CONNECTIONS PROVIDE ADEQUATE EMI/RFI SHIELDING.

3.3.3.1 PRIMARY INPUT POWER

The power cord receptacle and fuse block are located in the same assembly. Insert the power cord into the power cord receptacle.

CAUTION: POWER IS APPLIED TO THE INSTRUMENT'S CIRCUITRY AS LONG AS THE INSTRUMENT IS CONNECTED TO THE POWER SOURCE.



The standard power supply requires 110 VAC, 50/60 Hz or 220 VAC, 50/60 Hz (optional) power.

3.3.3.2 FUSE INSTALLATION

The fuse block, at the right of the power cord receptacle, accepts US or European size fuses. A jumper replaces the fuse in whichever fuse receptacle is not used.

3.3.3.3 50-PIN EQUIPMENT INTERFACE CONNECTOR

Figure 3-2 shows the pin layout of the Equipment Interface connector. The arrangement is shown as seen when the viewer faces the rear panel of the analyzer. The pin numbers for each input/output function are given where each function is described in the paragraphs below.

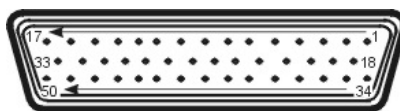

Figure 3-2: Equipment Interface Connector Pin Arrangement

3.3.3.4 ANALOG OUTPUT

There are four DC output signal pins—two pins per output. For polarity, see Table 3-1. The outputs are:

0–1 VDC % of Range: Voltage rises linearly with increasing concentration, from 0 V at 0

	concentration to 1 V at full scale. (Full scale = 100% of programmable range.)
0–1 VDC Range ID:	0.20 V = Low Range 0.5 V = Medium Range 0.80 V = High Range
4–20 mA DC % Range:	Current increases linearly with concentration, from 4 mA at 0 concentration to 20 mA at full scale. (Full scale = 100% of programmable range.)
4–20 mA dc Range ID:	6.8 mA = Range 1 12.0 mA = Range 2 16.8 mA = Range 3

Table 3-1: Analog Output Connections

Pin	Function
3	+ Range ID, 4-20 mA, floating
4	– Range ID, 4-20 mA, floating
5	+ % Range, 4-20 mA, floating
6	– % Range, 4-20 mA, floating
8	+ Range ID, 0-1 VDC
23	– Range ID, 0-1 VDC, negative ground
24	+ % Range, 0-1 VDC
7	– % Range, 0-1 VDC, negative ground

Examples:

The analog output signal has a voltage which depends on gas concentration relative to the full scale of the range. To relate the signal output to the actual concentration, it is necessary to know what range the instrument is currently on, especially when the analyzer is in the autoranging mode.

The signal output for concentration is linear over the currently selected analysis range. For example, if the analyzer is set on a range that was defined as 0-10 ppm CH₄, then the output would be as shown in Table 3-2.

To provide an indication of the range, the Range ID analog outputs are used. They generate a steady preset voltage (or current when using the current outputs) to represent a particular range. Table 3-3 gives the range ID output for each analysis range.

Table 3-2: Analog Concentration Output—Example

ppm CH ₄	Voltage Signal Output (VDC)	Current Signal Output (mA DC)
0	0.0	4.0
1	0.1	5.6
2	0.2	7.2
3	0.3	8.8
4	0.4	10.4
5	0.5	12.0
6	0.6	13.6
7	0.7	15.2
8	0.8	16.8
9	0.9	18.4
10	1.0	20.0

Table 3-3: Analog Range ID Output—Example

Range	Voltage Signal Output (VDC)	Current Signal Output (mA DC)	Application
Range 1	0.20	6.8	0–1 ppm CH ₄
Range 2	0.50	12	0–10 ppm CH ₄
Range 3	0.80	16.8	0–100 ppm CH ₄

3.3.3.5 ALARM RELAYS

The nine alarm-circuit connector pins connect to the internal alarm relay contacts. Each set of three pins provides one set of Form C relay contacts. Each relay has both normally open and normally closed contact connections. The contact connections are shown in Table 3-4. They are capable of switching up to 3 amperes at 250 VAC into a resistive load. The connectors are:

Threshold Alarm 1:

- Can be configured as high (actuates when concentration is above threshold), or low (actuates when concentration is below threshold).
- Can be Configured as failsafe or non-failsafe
- Can be configured out (defeated).

Threshold Alarm 2:

- Can be configured as high (actuates when concentration is above threshold), or low (actuates when concentration is below threshold).
- Configured as failsafe or non-failsafe
- Can be configured out (defeated).

System Alarm:

- Actuates when DC power supplied to circuits is unacceptable in one or more parameters. Permanently configured as failsafe and latching. Cannot be defeated.

(Reset by pressing the STANDBY button to remove power. Then press STANDBY again and any other button **except** SYSTEM to resume

Further detail can be found in Chapter 4, Section 4.5.15.

Table 3-4: Alarm Relay Contact Pins

Pin	Contact
45	Threshold Alarm 1, normally closed contact

28	Threshold Alarm 1, moving contact
46	Threshold Alarm 1, normally open contact
42	Threshold Alarm 2, normally closed contact
44	Threshold Alarm 2, moving contact
43	Threshold Alarm 2, normally open contact
36	System Alarm, normally closed contact
20	System Alarm, moving contact
37	System Alarm, normally open contact

3.3.3.6 DIGITAL REMOTE CAL INPUTS

The digital remote calibration input accepts 0 V (off) or 24 VDC (on) for remote control of calibration. (See *Remote Calibration Protocol* below.) See Table 3-5 for pin connections.

The remote cal inputs are shared by the digital range selection mode. When the user selects the digital range selection mode, the input is used by the analyzer for range selection. See Section 4.6.14.3 *Digital Mode*.

Zero: Floating input. A 5–24 V input across the + and – pins puts the analyzer into the *Zero* mode. Either side may be grounded at the source of the signal. A 0–1 volt across the terminals allows *Zero* mode to terminate when done. A synchronous signal must open and close the external zero valve appropriately.

Span: Floating input. A 5–24 V input across the + and – pins puts the analyzer into the *Span* mode. Either side may be grounded at the source of the signal. A 0–1 volt across the terminals allows *Span* mode to terminate when done. A synchronous signal must open and close external span valve appropriately.

Cal Contact: This relay contact is closed while analyzer is spanning and/or zeroing. (See *Remote Calibration Protocol* below.)

Table 3-5: Remote Calibration Connections

Pin	Function
9	+ Remote Zero

- 11 – Remote Zero
- 10 + Remote Span
- 12 – Remote Span
- 40 Cal Contact
- 41 Cal Contact

Remote Calibration Protocol: To properly time the Digital Remote Cal Inputs to the Model 4020 Analyzer, the customer's controller must monitor the Cal Relay Contact.

When the contact is OPEN, the analyzer is analyzing, the Remote Cal Inputs are being polled, and a zero or span command can be sent.

When the contact is CLOSED, the analyzer is already calibrating. It will ignore your request to calibrate, and it will not remember that request.

Once a zero or span command is sent, and acknowledged (contact closes), release it. If the command is continued until after the zero or span is complete, the calibration will repeat and the Cal Relay Contact (CRC) will close again.

For example:

1. Test the CRC. When the CRC is open, Send a zero command until the CRC closes (The CRC will quickly close.)
2. When the CRC closes, remove the zero command.
3. When CRC opens again, send a span command until the CRC closes. (The CRC will quickly close.)
4. When the CRC closes, remove the span command.

When CRC opens again, zero and span are done, and the sample is being analyzed.

Note: The remote valve connections (described below) provides signals to ensure that the zero and span gas valves will be controlled synchronously.

3.3.3.7 RANGE ID RELAYS

There are three dedicated Range ID relay contacts. They are assigned to relays in ascending order—Low range is assigned to Range

1 ID, Medium range is assigned to Range 2 ID, and High range is assigned to Range 3 ID. Table 3-6 lists the pin connections.

Table 3-6: Range ID Relay Connections

Pin	Function
21	Range 1 ID Contact
38	Range 1 ID Contact
22	Range 2 ID Contact
39	Range 2 ID Contact
19	Range 3 ID Contact
18	Range 3 ID Contact
34	Not Used
35	Not Used

3.3.3.8 NETWORK I/O

A serial digital input/output for local network protocol. At this printing, this port is not yet functional. It is to be used in future options to the instrument. Pins 13 (+) and 29 (-).

3.3.3.9 PIN OUT TABLE

The following table summarizes all the outputs/inputs available in the 50 pin D-Sub connector on the backpanel of the analyzer.

Table 3-7: Pin out of 50 pin D-Sub Connector

pin #	Description
1	
2	
3	+ Range ID 4-20 ma
4	- Range ID 4-20 ma
5	+ Output 4-20 ma
6	- Output 4-20 ma
7	- Output 0-1 v
8	+ Range ID 0-1 v
9	Remote Zero +
10	Remote Span +
11	Remote Zero -

pin #	Description
12	Remote Span -
13	Network +
14	Remote Thermistor
15	Zero Solenoid Return
16	Span Solenoid Return
17	Span Solenoid Hot
18	Range 3 Contact
19	Range 3 Contact
20	Alarm 3 C Contact
21	Range 1 Contact
22	Range 2 Contact
23	- Range ID 0-1 v
24	+ Output 0-1 v
25	
26	
27	
28	Alarm 1 C Contact
29	Network -
30	Remote Sensor +
31	Remote Thermistor
32	Exhaust Solenoid Hot
33	Sample Solenoid Hot
34	Range 4 Contact/ not used
35	Range 4 Contact/not used
36	Alarm 3 NC Contact
37	Alarm 3 NO Contact
38	Range 1 Contact
39	Range 2 Contact
40	Calibration Contact
41	Calibration Contact
42	Alarm 2 NC Contact
43	Alarm 2 NO Contact
44	Alarm 2 C Contact
45	Alarm 1 NC Contact
46	Alarm 1 NO Contact
47	Remote Sensor -
48	Exhaust Solenoid Return
49	Zero Solenoid Hot
50	Sample Solenoid Return

3.3.4 RS-232 Port

The digital signal output is a standard RS-232 serial communications port used to connect the analyzer to a computer, terminal, or other digital device. It requires a standard 9-pin D connector.

Output: The data output is status information, in digital form, updated every two seconds. Status is reported in the following order:

1. The concentration in ppm
2. The range in use (R-1 = Range 1, R-2 = Range 2, R-3 = Range 3, R-4 = Range 4)
3. The span of the range (0- 10.00 ppm, etc)
4. Mode the analyzer is in: ANLZ, ZERO, or SPAN
5. Which alarms—if any—are tripped (AL-1 and/or AL-2).

Each status output is followed by a carriage return and line feed. For example:

```
5.88 ppm R-1 (0- 10.00 ppm) ANLZ AL-1 <CR>
```

Input: The input functions using RS-232 that have been implemented to date are described in Table 3-8.

Table 3-8: Commands via RS-232 Input

Command	Description
as<enter>	Immediately starts an autospan.
az<enter>	Immediately starts an autozero.

Implementation: The RS-232 protocol allows some flexibility in its implementation. Table 3-8 lists certain RS-232 values that are required by the Model 4020 implementation.

Table 3-9: Required RS-232 Options

Parameter	Setting
Baud	2400
Byte	8 bits
Parity	none
Stop Bits	1
Message Interval	2 seconds

3.3.5 Supporting Gases

Normally, four supporting gases of different composition (see Section 4.1: *Equipment*) will be required to operate the analyzer. The recommended composition of these gases is specified in the Application Data section of the Appendix. The gases should be supplied from cylinders that are equipped with the type of regulator specified in the aforementioned sections.

CAUTION: **UNDER NO CIRCUMSTANCES SHOULD YOU EMPLOY A REGULATOR THAT IS NOT EQUIPPED WITH A METALLIC DIAPHRAGM ANYWHERE IN THE SYSTEM.**



The regulators should be inspected prior to installation to be sure that they are oil-free. Failure to comply with these directives will result in a constant drift in analyzer output, as organic compounds will outgas into the plumbing system at a rate that is related to the ambient temperature. Use 316 stainless steel, dual-stage regulators only in fuel, sample, and blanket air lines; shutoff valves should be used downstream from each regulator.

Place the supply cylinders as close to the analyzer as possible, and interconnect them to the analyzer with new tubing. Be sure that all plumbing connections are free of leaks.

Note: Use only stainless steel tubing throughout the system. Consult the assembly, piping, outline drawings, and any Addenda included with this manual to determine if special conditions apply.

3.3.5.1 SAMPLE GAS

An oil-free, metallic diaphragm regulator must be installed as close to the sample point as possible. Use new tubing in the installation. The output pressure of the regulator should be 15 psig [103 Kpa], whenever possible, to match the settings of other regulators on the support gas tanks; sample inlet pressure must exceed the operating sample pressure by at least 10 psig [69 Kpa] and provide at least 1 SCFH bypass flow. In any case, the zero and span gas regulators should be set to match the sample pressure regulator—as the back-pressure regulator within the analyzer ultimately determines the sample flow to the detection cell. Refer to Chapter 4: *Sampling*.

3.3.5.2 EFFLUENT

All the gases introduced into the detection cell vent from one fitting at the rear of the analyzer. TAI recommends that the cell be permitted to vent directly to the atmosphere wherever possible.

If a vent line is required, the installation must include a drop-out pot to collect the water that is formed by the burning of the hydrogen fuel. The vent line must be constructed so that water and dirt cannot collect in it.

3.3.5.3 SAMPLE BYPASS VENT

The sample bypassed by the back-pressure regulation system vents from a separate port at the rear of the analyzer. If a vent line is required, it must be installed so that water and dirt cannot accumulate in it.

3.3.5.4 FUEL AND AIR CONNECTIONS

The fuel used to provide combustion should be a gas mixture comprised of 40% H₂ and 60% N₂. The fuel is mixed with air to provide a combustion source for the analyzer. Connect the fuel and air sources to

the instrument according to the gas connection diagram included at the back of this manual.

Note: For applications where the sample gas is hydrogen, the sample gas doubles as the fuel for combustion and is diluted with nitrogen. Connect a nitrogen source (15 psig [103 Kpa]) to the fuel inlet port. See Figure 3-1.

Note: A gas mixture of 40% H₂ and 60% He can be used as fuel as well.

Operation

This section of the manual describes how to setup and operate the Model 4020 Analyzer. Sections 4.1 through 4.5 describe preliminary steps and equipment needed to operate the analyzer. Beginning with Section 4.6, the actual operation of the analyzer is described along with descriptions of the display prompts, messages and options available to the user within a menu or sub menu.

4.1 Equipment

The following supporting gases and hardware will be required to operate the (standard) analyzer:

1. **Fuel:** A cylinder containing a 40% hydrogen, 60% nitrogen composition will be required to supply the fuel for the flame ionization burner. The cylinder is to be equipped with an oil-free metallic diaphragm regulator (dual stage).

Note: When hydrogen is the parent gas in the application, an auxiliary source of fuel may not be required. See the Appendix: Specifications for specific recommendations.

2. **Blanket Air:** A cylinder of water-pumped (low hydrocarbon) compressed air will be required to maintain the proper atmosphere within the cell. The cylinder is to be equipped with an oil-free, dual stage, metallic diaphragm regulator. Less than 1% of the full scale reading (in the selected measurement range) of hydrocarbon contamination is advisable, if the instrument's accuracy is to be realized.
3. **Zero Gas:** A cylinder of the parent (or background) gas, containing less than 10% full scale (of the narrowest range) hydrocarbon impurity, will be required to zero standardize the analyzer. For example, if 10 PPM is the narrowest range of the instrument, then the zero gas impurities are to be less than 1 PPM. The cylinder is to be equipped with an oil-free, dual stage, metallic diaphragm regulator.

4. **Span Gas:** A cylinder containing a composition consisting of the parent gas and a specified (see Appendix: Specifications) amount of methane will be required to standardize the sensitivity setting of the analyzer. The cylinder is to be equipped with an oil-free, dual stage metallic diaphragm regulator.

Note: The analyzer is capable of analyzing a sample in two different background gases, O₂ and N₂. To use this feature you must calibrate the instrument with each background gas. Therefore separate zero and span gases will be required for each background gas.

5. **Sample Pressure Regulation:** An oil-free, metallic diaphragm regulator must be installed at the sample point when possible; see Section 3.3.5.1 *Sample Gas*.
6. **Background Gas Selector:** If using different sample background gases, a suitable manifold for switching the gas to the analyzer will be required. It can be either manual or automatically operated valves.

4.2 Preliminary Power-Off Check List

Make the following checks of the installation before proceeding further into the start-up procedure:

1. Check to see that the sample and supporting gas installation is in accordance with the specifications called for in the installation and application sections of the manual (Chapter 3). Be sure that the supporting gases are of the proper composition and are connected to the correct fittings at the rear of the analyzer.
2. Check to see that the electrical installation conforms to the instructions contained in the installation section (Chapter 3) and on the input-output diagram.
3. Open the door and check to see that the printed circuit boards and cables are firmly seated in their respective sockets.
4. Confirm that recorder and alarm connections are properly made.

4.3 Placing the System in Operation

1. Turn the power switch to the ON position.



2. Allow at least 2 hours warm-up (heat up sensor & sample system) after making the air adjustment described below. Warm up time is set by the software at the factory.

DO NOT attempt to ignite the flame during warm up countdown. Condensation will occur.

4.4 Activating the Support Gases

4.4.1 Air

1. Set the air tank regulator to 15 psig [103 Kpa].
2. Adjust the instrument air regulator until the air pressure gauge reads the recommended air pressure.

After the air is flowing through the sensor and warm-up time has been completed, activate the following gases:

4.4.2 Sample Gas

Set the sample gas tank regulator to 3 psig (or a pressure which matches the sample pressure) and adjust the instrument sample regulator until its (sample) pressure gauge reads the recommended sample pressure.

4.4.3 Span Gas

1. Feed span gas to the analyzer. This instrument has an automatic valve selection feature for directing sample or calibration gas to the analyzer. See Section 4.6.17 for setup and operation of the valve selection feature..
2. Set the span gas regulator to 15 psig or to match the sample pressure.
3. Observe that the instrument sample pressure gauge still reads the recommended sample pressure and that the bypass flowmeter reads from 0.5 to 1.0 SCFH.

4.4.4 Fuel

1. Open the main valve on the tank and set the fuel tank pressure regulator to 15 psig (or to match sample pressure).

2. To avoid pressure shock to the instrument fuel regulator, slowly open the secondary valve until it is wide open.

Note: adjust fuel settings only when the red LED (flame failure light) is off.

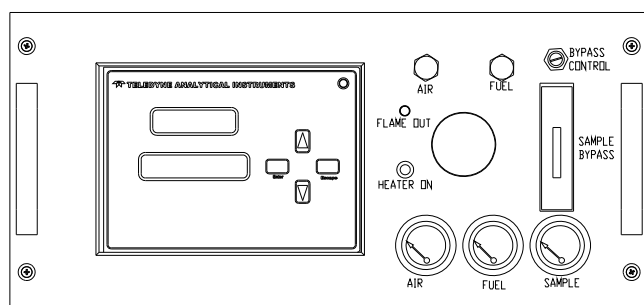

Figure 4-1: Front Panel View of Regulator and Gages

4.5 Flame Ignition

Observe that after warm up count down timer reaches zero (timer to preheat the sensor), the amber heater lamp is blinking (indicating that the temperature controller is maintaining the temperature setpoint) and the red flame failure lamp is on. See Figure 4-1.

The Model 4020 will automatically attempt a flame ignition sequence following the warm-up period which has been preset at the factory. If the ignition process fails, the instrument will attempt to ignite the flame a second time. If it continues to fail after the fifth attempt, a flame failure message will appear on the display. If this occurs refer to Section 5.

4.5.1 Verification of the Flame Guard Circuit

The operation of the flame guard circuit has been checked at the factory, but should be re-verified during start-up. Use the following procedure after ignition of the flame has been achieved:

1. Turn off the fuel at the supply cylinder.
2. Observe the fuel pressure gauge on the analyzer control panel. The gauge indication will decay as the fuel in the line is exhausted. When the gauge reading reaches the vicinity zero, the flame will be extinguish as the fuel solenoid shuts off the fuel supply. The analyzer will automatically try to re-ignite. After 5 attempts, it will display: flame failure, check air, fuel and the flame failure LED will be on.
3. Open the cylinder supply valve and re-ignite the flame.

4.5.2 Ignition and/or Flame Guard Circuit Failure

If the flame ignition or guard circuits do not operate as described in the above two sections, set the instrument fuel regulator to the recommended pressure. If still fails to ignite, proceed as directed in Chapter 5: *Maintenance & Troubleshooting*.

4.6 Analyzer Operation

Although the Model 4020 has been programmed for your application at the factory, it can be further configured at the operator level, or even (cautiously) reprogrammed. Depending on the specifics of the application, this might include all or a set of the following procedures:

- Setting system parameters
 - Establish a security password, if desired, requiring operator to log in
 - Establish and start an automatic calibration cycle
- Routine operation
 - Calibrate the instrument
 - Choose autoranging or select a fixed range of analysis
 - Set alarm setpoints and modes of alarm operation (high, low, failsafe, etc.)
- Program/reprogram the analyzer
 - Linearize the ranges

- Special functions setup
 - Calibrate analog output

Procedures for accessing and/or changing parameters as well as analyzer operation are detailed in the sections to follow. In general, the sequence of menus available on screen follow a logical course for setup and operation. It is not required, however to follow this sequential path. The user could, for instance, go directly to set an analysis range and then program an offset to the current output for matching a range on the user's recording device. The only exception to this is when the instrument is powered up. It will go through a diagnostic self-test routine and, if programmed to do so, request a password to be entered before allowing access to any function.

4.6.1 Default Parameters

The versatility of this analyzer usually results in significant changes being made to parameters over the course of time to better suit a particular application. Occasionally processes change requiring alteration to alarms, filter settings etc. At some time, it may be beneficial to reset the analyzer to the default conditions as it was when shipped from the factory. Below is a listing of the default parameters used in configuring your instrument:

Range/Application: Refer to the data sheet on the application page found in the appendix of this manual

Range: Manual

Alarm Relays: Active, HI, 80 ppm (alarm 1),
90 ppm (alarm 2), non-failsafe

Zero: Auto disabled, every 7 days, at 12 hours

Span: Auto disabled, every 7 days, at 12 hours

Password: TAI

4.6.2 Style Conventions

The following typeface conventions are used when referring to screen names, key presses and screen readout:

Screens: Arial 12 pt. type in capital letters. Example:
ANALYZE or MAIN screen or menu.



Key presses:	<key> The particular keystroke to enter is placed between < and >. Example: <enter> or <escape> or <▲> (UP key) or <▼> (DOWN key). Only when the keystroke is to be entered will it be placed between the brackets. If discussing a particular key it will be typed as text using all caps. Example: this is the ENTER key.
Screen Modes:	Times New Roman 12 pt. italic. Example: <i>Analysis Mode</i> or <i>Setup Mode</i> .
Screen Readout:	Arial Narrow, 12 pt bold. Example: AUTOCAL or Zero in 12 days.

4.6.3 Using the Controls

To get the proper response from these controls, press the desired key (<Escape> or <Enter> or <▲▼>. To enter the screen menu, press any key.

The item that is adjacent to the arrow on the screen as shown in Figure 4-2, is the item that is currently selectable by pressing the <Enter> key.



Figure 4-2: Typical VFD Screen Layout

In these instructions, to <Enter> means to press the ENTER KEY, and to <Escape> means to press the ESCAPE KEY. To scroll <▲> (or scroll <▼>) means to press UP or DOWN keys as many times as necessary to reach the required menu item.

4.6.4 Mode/Function Selection

When the analyzer is first powered up, a warm-up for a period ranging from 1 to 16 hours will occur depending on the exact factory configuration.

Note: The warm-up period may be bypassed by pressing

<Enter> at the initialization screen.

The warm-up period is a crucial factor affecting the overall accuracy for this instrument and should not be bypassed unless the instrument has only been off for a short period or for maintenance purposes. Check *Specific Model Information* on page iii of this manual as well as any accompanying Addenda for the specific warm up time required for your configuration.

After warm-up, the instrument will undergo an initialization and self diagnostic routine. Once this has been completed, the ANALYZE screen (*Analysis Mode*) will appear. The ANALYZE screen is the only screen of the *Analysis Mode*. It is also the default screen appearing whenever the instrument is on and not in the warm-up phase, self testing routines or purposely put into another mode of operation such as *Setup Mode*. The analyzer will automatically return to the ANALYZE screen from any other input screen whenever the instrument is idle with no buttons pressed for approximately 20 seconds.

The MAIN MENU screen is the top level in a series of screens used in the *Setup Mode* to configure the analyzer for the specific application. The DOWN/ UP commands scroll through the options displayed on the VFD screen. The selectable option appears between arrows. When you reach the desired option by scrolling, <Enter> the selection as described below.

ESCAPE takes you back up the hierarchy of screens until you reach the *Analyze Mode*. ESCAPING any further just toggles between the MAIN MENU and the ANALYZE screen.

Note: The main menu or any sub menu will time out after approximately 20 seconds, and return to the analyze screen.

4.6.4.1 ANALYSIS MODE

This is the normal operating mode. The analyzer monitors the concentration of the sample, displays the percent of the concentration in the sample stream, and warns of any alarm conditions. Pressing any key switches you into *Setup Mode* and brings up its main menu. *Setup Mode* switches back to *Analyze Mode* if no controls are used for more than twenty seconds.

4.6.4.2 SETUP MODE

The MAIN MENU consists of functions you can use to customize and check the operation of the analyzer. Figure 4-3 shows the functions available in the Model 4020. They are listed here with brief descriptions:

- AUTO-CAL: (Option) Used to define and/or start an automatic calibration sequence.
- PSWD: Used to establish password protection or change the existing password.
- LOGOUT: Logging out prevents unauthorized tampering with the analyzer settings.
- MODEL: Displays Manufacturer, Model, and Software version of the instrument.
- SELF-TEST: The instrument performs a self-diagnostic routine to check the integrity of the power supply, output boards, cell and amplifiers.
- SPAN: Set up and/or start a span calibration.
- ZERO: start a zero calibration.
- ALARMS: Used to set the alarm setpoints and determine whether each alarm will be active or defeated, HI or LO active, and failsafe or not.
- RANGE: Used to set up three analysis ranges that can be switched automatically with auto-ranging or used as individual fixed ranges. A digital range selection mode is incorporated that uses the remote calibration inputs for range selection.
- FILTER: This function sets the digital filter from 0 to 7, 0 being the fastest response time, and 7 being the slowest. The default is 4.
- ANALOG-OUT ADJUST: Calibrate Analog Output
- LINEARIZATION: A restricted function not generally accessed by the end user. It is used to linearize the output for the range of interest.

- **BACKGROUND GAS:** Allows the user to choose between nitrogen or oxygen as the background gas.

Note: Each background gas has its own zero settings. The first time you switch from one background gas to the other, the instrument must be zero calibrated on that gas.

- **VALVE SELECTIONS:** Allows the user to switch between sample and calibration gases from an input screen or automatically depending on the instrument's mode of operation. Valve selection can also be disabled.
- **STANDBY:** Removes power to outputs and displays, but maintains power to internal circuitry.

Any function can be selected at anytime. Just scroll through the **MAIN MENU** with the **DOWN/UP** keys to the appropriate function, and **ENTER** it. The analyzer will immediately start that function, unless password restrictions have been assigned. (Password assignment is explained in Section 4.6.7).

4.6.5 Data Entry

4.6.5.1 ENTER

The **ENTER** key is used in several context-sensitive ways.

1. When the selected option is a function on the **MAIN MENU** screen, the function name appears with an arrow next to it. The **ENTER** key is used to activate the function. The next screen for that function or sub function will appear on the **VFD**.
2. If the selected option is a modifiable item, the **UP** or **DOWN** keys are used to increment or decrement the item to the value or action you want. The **ENTER** key is then used to accept the value and move you to the next field to continue programming.
3. When the last field is entered, **ENTER** takes you to the next screen in the process, or if the process is completed, **ENTER** takes you back to the **ANALYZE** screen.

4.6.5.2 ESCAPE

Pressing the **ESCAPE** key takes you back to the previous screen.



If you do not wish to continue a function, you can abort the session by escaping. Escaping a function takes the analyzer back to the previous screen, or to the ANALYZE Function, depending on the nesting level of screens in the function you are moving out of.

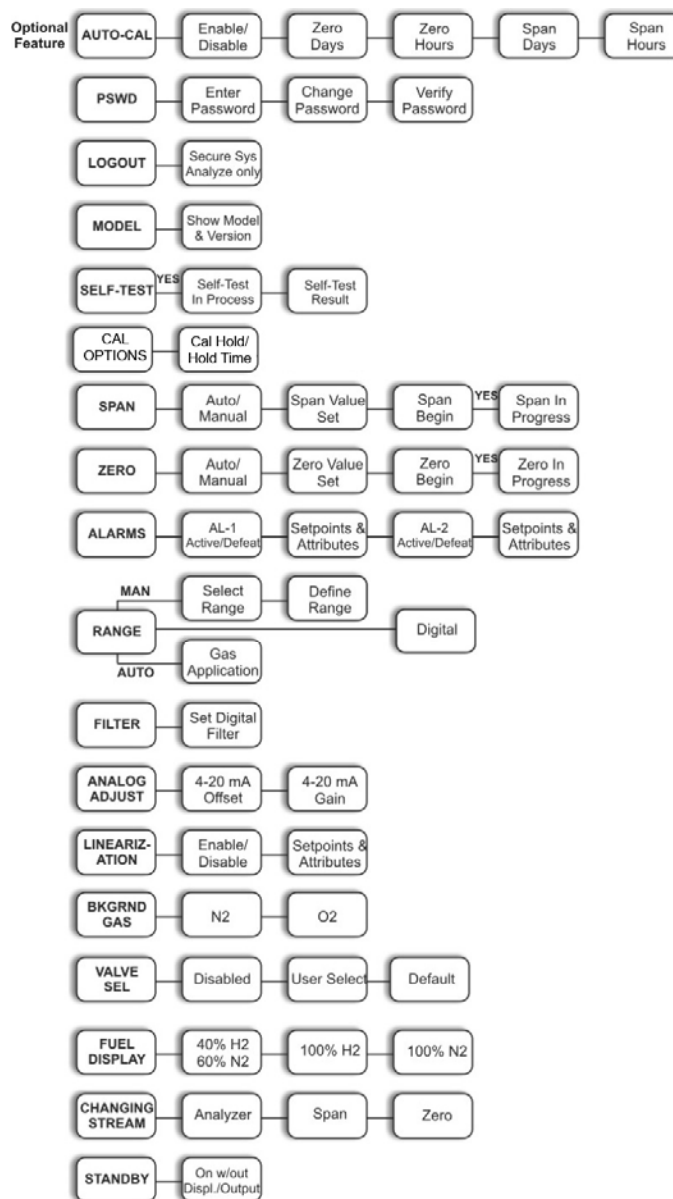

Figure 4-3: Setup Mode Functions

4.6.6 Setting up an AUTO-CAL

If the analyzer is equipped with the optional auto-calibration feature (see Chapter 3, *Installation*), the analyzer can cycle itself through a sequence of steps that automatically zero and span the instrument (auto calibration or autocal).

Note: Before setting up an AUTOCAL, be sure you understand the Zero and Span functions as described in Section 4.6.15, and follow the precautions given there.

Note: If you require highly accurate AUTOCAL timing, use external AUTOCAL control where possible. The internal clock in the Model 4020 is accurate to 2-3 %. Accordingly, internally scheduled calibrations can vary 2-3 % per day.

Note: By default, AUTOCAL is off.

To setup an AUTOCAL cycle for a zero or span event to occur in a certain number of days:

<any key> Press any key to enter the *Setup Mode*. The VFD will display the first 2 lines of functions available.



<▲ ▼> If the arrow is not adjacent to the AUTOCAL menu item, use the ▲ ▼ keys to move the arrow to the proper position.

<Enter> Press <Enter> to activate the function and move you to the next screen.

This screen allows you to either enable or disable the AUTOZERO or AUTOSPAN functions independently. To set up an autocal event, the appropriate AUTOCAL function (AUTOZERO and/or AUTOSPAN) must be enabled.

<▲ ▼> If the screen indicates the specific AUTOCAL function is disabled, press <Enter>, then use the <▲ ▼> keys to toggle the enable/disable feature.

<Enter> Press <Enter> again to move to the next screen. As an example, in the case of an AUTOZERO, the arrow should now point to the line of text: **Zero in 7 days** as shown below.

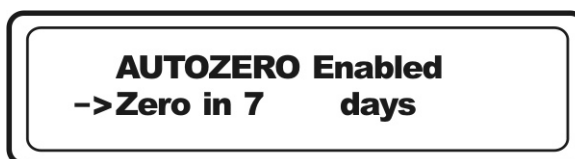

If you are setting a span calibration event press the <▼> key twice more and enable the AUTOSPAN function. Then press the <▼> key once more to bring the arrow to point to the line of text: **Span in 7 days**.

With the arrow adjacent to the text: **Zero in 7 days**, (or **Span in 7 days**) if you want to change the day count, highlight the number by pressing <Enter>.

<▲ ▼> With the number highlighted, use the <▲ ▼> keys until the proper day count value is on screen.

<Enter> Press <Enter>. This accepts the value and moves the arrow to the next screen line.

Note: You can always press <Escape> to move to the previous screen line. Repeated Escaping will bring you back to the MAIN MENU. Pressing <Escape> at the MAIN MENU will place the instrument in Analysis Mode.

To have a zero (or span) event occur in an hourly time frame is similar to the above procedures except that you must scroll from the MAIN MENU using the <▼> key until the appropriate line is reached. Figure 4-4 shows the set of screens used in the AUTOCAL function.

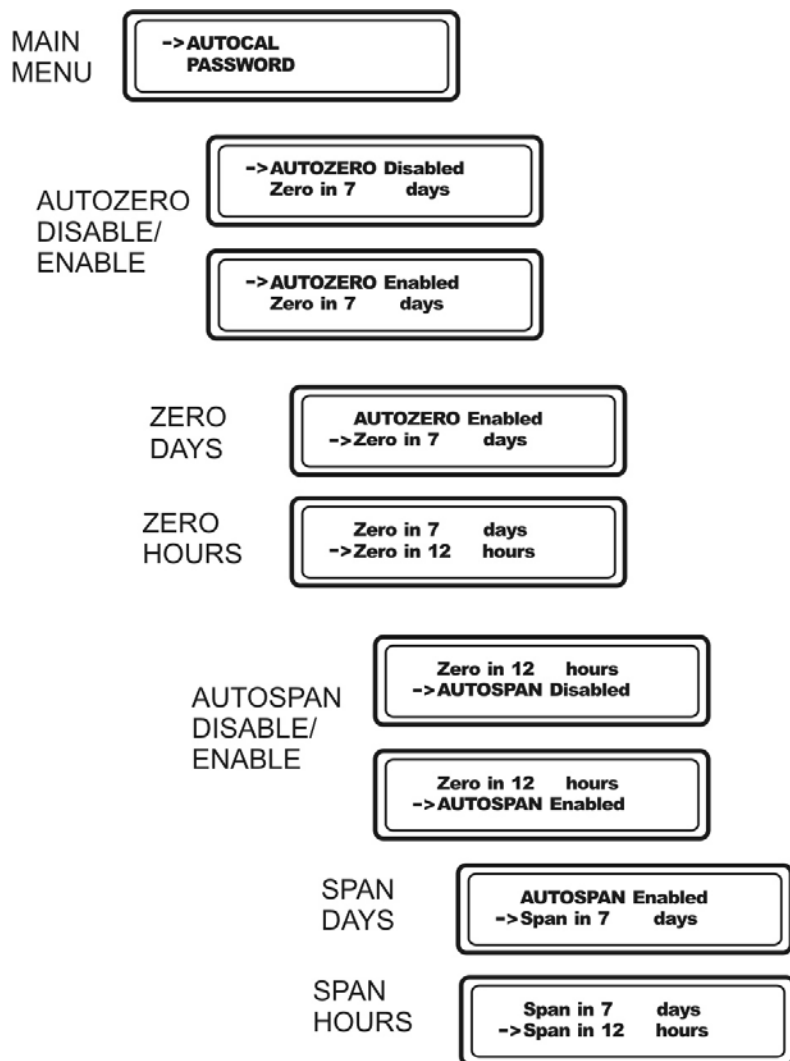

Figure 4-4: AUTOCAL Screens

4.6.7 Password Protection

Before a unique password is assigned, the system assigns TAI by default. This password will be displayed automatically. The operator just presses <Enter> to be allowed total access to the instrument's features.

If a new password is assigned, then all system parameters can be set after the password is correctly entered. When logged out, only the MODEL function, an information only screen, is available.

Note however, that the instrument can still be used for analysis or for initiating a self-test without entering the password. To defeat security the password must be changed back to TAI.

Note: If you use password security, it is advisable to keep a copy of the password in a separate, safe location.

To log in, enter the correct password as described in the next section. To logout, use the LOGOUT function as described in Section 4.6.8.

4.6.7.1 ENTERING THE PASSWORD

To install a new password or change a previously installed password, you must key in and ENTER the old password first. If the default password is in effect, pressing <Enter> will enter the default TAI password for you.

To enter a password:

<any key> Enter MAIN MENU setup by pressing any key.

<▲ ▼> Use the UP or DOWN key to scroll to PSWD.



**AUTOCAL
-> PASSWORD**

<Enter> Press <Enter> to activate the password function. Either the default TAI password or AAA place holders for an existing password will appear on screen depending on whether or not a password has been previously installed.



**Enter Password
'T' 'A' 'I'**

<Enter> The screen prompts you to enter the current password. If you are not using password protection, press <Enter> to accept TAI as the default password.

—or—

<Enter> If a password has been previously installed, enter the password press <Enter> to scroll through the letters.

<▲▼> Use the ▲▼ keys to change the letters to the proper password.

<Enter> The last <Enter> enters the password.

In a few seconds, you will be given the opportunity to change this password or keep it and go on.



<Enter or Escape> Press <Escape> to move on, or <Enter> to change the password.

4.6.7.2 INSTALLING OR CHANGING THE PASSWORD

If you want to install a password, or change an existing password, proceed as above in *Entering the Password*. When you are given the opportunity to change the password press <Enter>.

If you elected to change the password, the password assignment screen appears.

<Enter> Use <Enter> to move to the character(s) you want to change.

<▲▼> Use the UP and DOWN keys to cycle between the available characters from the embedded character set.

<Enter> Press <Enter> to accept the character.

<Enter> Press <Enter> to bring up the password verification screen.

Use the same process of <Enter> to select the character position followed by <▲▼> to type in the characters of the password. The last <Enter> will verify your password and store it in the microprocessor.

You will now be automatically returned to the *Analyze Mode*.

Note: If you log off the system using the LOGOUT function in the MAIN MENU, you will now be required to reenter the password to gain access to Alarm and Range functions.

4.6.8 Logging Out

The LOGOUT function provides a convenient means of leaving the analyzer in a password protected mode without having to shut the instrument off. By entering LOGOUT, you effectively log off the instrument leaving the system protected against use until the password is reentered.

To log out:

<▲ ▼> From the MAIN MENU scroll to field of LOGOUT function.

<Enter> Press <Enter> to logout
The screen will display the message:



Pressing <Enter> will logout the current user and protect the system from unauthorized changes to parameters. All users will still have access to the SELF-TEST function and the instrument will function normally in *Analyze Mode*. If you press <Escape>, the current password will still be in effect and the user has not logged off.

4.6.9 System Self-Diagnostic Test

The Model 4020 has a built-in self-diagnostic testing routine. Preprogramming signals are sent through the power supply, output board, preamp board and sensor circuit. The return signal is analyzed, and at the end of the test the status of each function is displayed on the screen, either as GOOD or BAD. If any of the functions fail, the System Alarm is tripped. The following is an example of what is displayed at the end of the diagnostic routine.

5 Volts Test – GOOD (status of the 5 volt power supply)
15 Volts Test – GOOD (status of the +/-15 volt power supply)
DACA Test – GOOD (status of the % of range analog output)
DACB Test – GOOD (status of the range ID analog output)
Pre-L Test – GOOD (status of the low gain of the amplifier)

Pre-M Test – GOOD (status of the medium gain of the amplifier)

Pre-H Test – GOOD (status of the high gain of the amplifier)

Note: The self diagnostics are run automatically by the analyzer whenever the instrument is turned on, but the test can also be run by the operator at will.

To initiate a self-test:

- <▲ ▼> From the MAIN MENU scroll to the SELF-TEST function.
- <Enter> Activate the SELF-TEST function by pressing <Enter>. This brings up the SELF-TEST initialization screen.

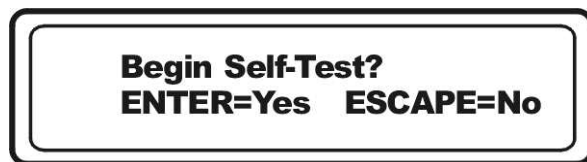

- <Enter or Escape> Start the diagnostic testing routine by pressing <Enter> or cancel out by pressing <Escape>.

If you pressed <Enter> the self-test routine will begin and after a few moments the results will appear onscreen. The module is functioning properly if it is followed by OK. A number indicates a problem in a specific area of the instrument. Refer to Chapters *Maintenance and Troubleshooting* for number-code information.

To return the analyzer to the MAIN MENU, press <Enter> after the results screen.

If you pressed <Escape> you will be returned to the *Analyze Mode*.

4.6.10 The Model Screen

The MODEL screen displays the manufacturer, model, and software version information. It is accessed via the MAIN MENU by scrolling (▲ ▼) to MODEL and pressing <Enter>.

4.6.11 Calibration Options

The CAL OPTIONS screen can be used to freeze the analog output signals for a set time after performing a SPAN or ZERO calibration. This will allow the calibration to progress without triggering alarms as the calibration gas is replaced with sample gas. If this option is enabled, the user can specify the hold time.

To enable or disable the calibration hold feature:

<▲ ▼> From the MAIN MENU scroll to CAL OPTIONS function.



<Enter> Enter the CAL-OPTIONS function by pressing <Enter>. This brings up the CAL HOLD screen.

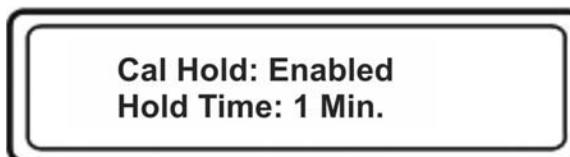

<Enter> Use <Enter> to move to the Enabled/Disabled option in the Cal Hold field.

<▲ ▼> Use the UP and DOWN keys to cycle between Enabled or Disabled.

<Enter> Press <Enter> to accept the desired state.

<▲ ▼> If 'Enabled' is selected, use the UP and DOWN keys to adjust the desired hold time.

<Enter> Press <Enter> to accept the hold time.

4.6.12 Zero and Span Functions

The ZERO and SPAN functions are used to calibrate the analyzer. These functions can be performed either manually or automatically (if equipped with the autocal option). The ZERO and SPAN are separate functions but operate similarly with one exception regarding the offset to the zero level in manual mode. Hence, the description that follows refers to the ZERO function but the same procedure is used for SPAN (but without the offset screens).

The analyzer is calibrated using zero and span gases as described in Section 4.1. This section assumes that these gases have been properly connected and the lines checked for leaks.

Note: You must zero and span calibrate the instrument with each background gas (O₂ or N₂) you intend on using.

To initiate a zero (span) calibration, first inform the instrument which background gas is being used:

- <▲ ▼> From the MAIN MENU, scroll down to the Background Gas function.
- <Enter> Press <Enter> to activate the Background Gas function.
- <▲ ▼> Use the UP or DOWN key to toggle between O₂ and N₂ until the correct background gas is displayed.
- <Enter> Press <Enter> again to inform the instrument which gas is being used for the background gas.

The parameters for the calibration that follows will be stored in memory for the background gas selected.

- <▲ ▼> From the MAIN MENU, scroll down to the ZERO (SPAN) function.
- <Enter> Press <Enter> to activate the ZERO (SPAN) function. The next screen will prompt you to select either manual or automatic Zero calibration.

Manual Zero (Span)

If you select manual zero (span), the next screen will allow you to enter the concentration in ppm hydrocarbon (methane equivalent) of your zero(span) gas.



Note: Make sure that the proper calibration gas is flowing into the analyzer before initiating this function. Depending on your sample system, you may have to flow calibration gas for several minutes to purge the gas line of sample gas.

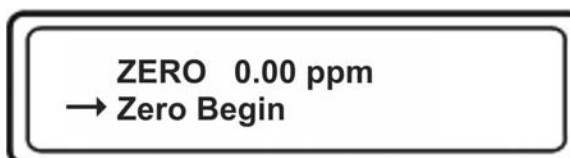

<Enter> With the arrow adjacent to Zero (Span) as shown above, press <Enter> to activate the sub function.

<▲ ▼> Use the UP/DOWN keys to increment or decrement the concentration value until the known value of your zero(span) gas concentration is displayed.

<Enter> Press <Enter> to accept this value.

<▼> Press the DOWN key once to move the arrow down one line to the text Zero (Span) Begin.

<Enter> Press <Enter> to start the calibration.

A confirmation screen will appear where you can either start the zero (span) calibration or escape (ESC) back to the previous menu.

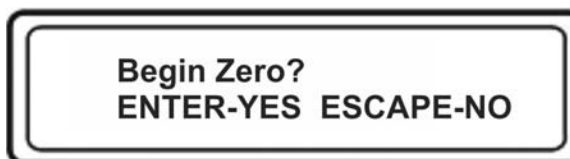

Pressing ENTER, the 4020 will begin to capture the individual gain for the specific ranges that have been set. The first of three screens will appear, one for high gain, one for medium gain and the last for low gain. The user can set the offset by pressing ENTER when the appropriate offset appears on the screen.

The screens appear as follows:



-0.334ppm ZERO
<ENT> for next (g-H)



-0.622ppm ZERO
<ENT> for next (g-L)



-0.414ppm ZERO
<ENT> for next (g-M)

Pressing ENTER will set the offset for that range.

For instance if the ranges have been set to LOW = 10 ppm, MED = 100 ppm, HIGH = 1000PPM and the desired zero offsets are -0.334 for low range, -0.6662 ppm on the medium range, and -0.414 ppm on the high range then the user must press <Enter> when the display reaches that point. This will set the offset and begin the same process for the next range. If no offset is required, simply wait until the display stabilizes at zero.

Note: An appropriate zero gas must be flowing during this operation.

Following the gain capture, the 4020 will begin to analyze the concentration of the zero (span) calibration gas and LED display above the VFD will change to reflect the calibration gas concentration as the analysis proceeds. Internally, the microprocessor calculates the difference between successive samplings and displays the concentration as it changes. In MANUAL mode, the operator can terminate the calibration at any point by scrolling to **Finish** and pressing <Enter>. Wait until the concentrations as shown on the screen stabilizes before ending the calibration. After terminating the calibration the zero (span) value will be stored in the microprocessor's memory and you can continue with additional calibration or escape to *Analyze Mode*.

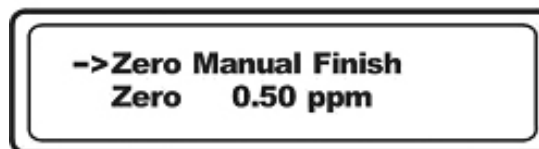

If you will be using a second background gas, repeat the above procedures for the second background gas.

Auto Zero

If you selected **Auto** for the zero calibration, The microprocessor will determine the appropriate termination point for the zero or span calibration based on the rate of change of concentration with time as the value approaches the zero (span) concentration you entered for the zero (span) gas.

To automatically zero (span) the instrument, make sure the proper background gas is selected as described above, then:

- <▲ ▼> From the MAIN MENU, scroll down to the ZERO (SPAN) function.
- <Enter> Press <Enter> to activate the ZERO (SPAN) function. The next screen will prompt you to select either manual or automatic Zero calibration.
- <▲ ▼> Choose Auto zero (span) by toggling between **Manual** and **Auto** using the UP/DOWN keys.
- <Enter> Select Auto by pressing <Enter>.

The next screen will allow you to enter the concentration in ppm hydrocarbon (methane equivalent) of your zero(span) gas.

Note: Make sure that the proper calibration gas is flowing into the analyzer before initiating this function. Depending on your sample system, you may have to flow calibration gas for several minutes to purge the gas line of sample gas.

Also, make sure that the correct background gas is selected in the Background Gas screen. See Section 4.7.2 Background Gas Selection.



->Zero 0.50 ppm
Zero Begin

- <Enter> With the arrow adjacent to **Zero (Span)** as shown above, press <Enter> to activate the sub function.
- <▲ ▼> Use the UP/DOWN keys to increment or decrement the concentration value until the known value of your zero(span) gas concentration is displayed.
- <Enter> Press <Enter> to accept this value.
- <▼> Press the DOWN key once to move the arrow down one line to the text **Zero (Span) Begin**.
- <Enter> Press <Enter> to start the calibration.

The calibration process will initiate and after a few moments the LED digital display will indicate the zero or span gas concentration and the VFD display will inform the user it has finished the calibration.

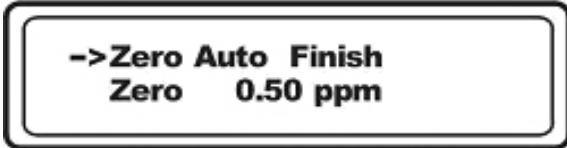

->Zero Auto Finish
Zero 0.50 ppm

- <Enter> To accept the calibration, press <Enter>. To reject this calibration and repeat the process, press <Escape>.

The zero (span) process will automatically conclude when the output is within the acceptable range for a good zero (span). If accepted by the operator, the analyzer automatically returns to the *Analyze mode*.

4.6.13 The Alarms Function

The Model 4020 is equipped with 2 fully adjustable concentration alarms and a non-adjustable system failure alarm. Each alarm relay has a set of form "C" contacts rated for 3 amperes resistive load at 250 VAC. See Figure in Chapter 3, *Installation* and/or the Interconnection Diagram included at the back of this manual for relay terminal connections. The alarm relay contacts are accessible to the user from the 50-pin Equipment Interface connector.

The system failure alarm has a fixed configuration described in Chapter 3 *Installation*.

The concentration alarms can be configured from the ALARM function screen as either high or low alarms by the operator. The alarm modes are set at the factory as non-failsafe however they can be defeated by the operator from within the ALARM function screen. In failsafe mode, the alarm relay de-energizes in an alarm condition. For non-failsafe operation, the relay is energized in an alarm condition.

The setpoints for the alarms are also established using this function.

Prior to programming the alarms you should decide how they should be configured. The choice will depend upon your process. Consider the following points:

- Which if any of the alarms are to be high alarms and which if any are to be low alarms?

Setting an alarm as HIGH triggers the alarm when the concentration rises above the setpoint. Setting an alarm as LOW triggers the alarm when the concentration falls below the setpoint.

- Are the alarms to be set as:
 - Both high (high and high-high) alarms
 - One high and one low alarm
 - Both low (low and low-low) alarms.
- Are the alarm contacts to be fail safe or non-fail safe?
- Are either of the alarms to be defeated?

The defeat alarm mode is incorporated into the alarm circuit so that maintenance can be performed under conditions which would normally activate the alarms.

Note: If you are using password protection, you will need to enter your password to access the alarm functions. Follow the instructions in section 4.6.7.1 to enter your password. Once you have clearance to proceed, you can enter the ALARM function.

To configure or set the alarms:

Activate or Defeat Alarms

<▲▼> Scroll to the ALARM function using the UP/DOWN keys.



<Enter> Activate the ALARM function by pressing <Enter>. This brings you to the next alarm screen which allows you to activate or defeat alarm 1.



<Enter> Press <Enter> to move to the Active/Defeat field.

<▲▼> Use the UP/DOWN keys to toggle between Active and Defeat.

<Enter> Press <Enter> to accept the entry and move the arrow to the next function (High/Low).

CAUTION:



IT IS NOT GOOD PRACTICE TO SILENCE AN EXISTING ALARM BY SETTING THE ALARM ATTRIBUTE TO 'DEFEAT'. THE ALARM WILL NOT AUTOMATICALLY RETURN TO "ACTIVE" STATUS. IT MUST BE RESET BY THE OPERATOR. IF IT IS NOT RESET, YOUR PROCESS WILL BE RUNNING WITHOUT SAFEGUARDS THIS INSTRUMENT IS DESIGNED TO PROVIDE.

Setting Alarms as High or Low

If the arrow is not already adjacent to the text High/Low, use the above procedure to relocate the arrow to this function as shown below.



<Enter> Press <Enter> to move to the High/Low field.

- <▲ ▼> Use the UP/DOWN keys to toggle between High and Low.
- <Enter> Press <Enter> to accept the change and move to the next alarm function.



Entering or Changing a Setpoint

If the arrow is not already adjacent to the text AL-X XX.XX ppm, use the above procedure to relocate the arrow to this function as shown below.

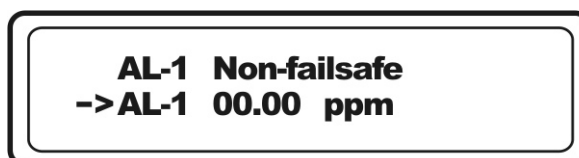

- <Enter> Press <Enter> to move to the setpoint field.
- <▲ ▼> Use the UP/DOWN keys to increase or decrease the value of the setpoint.
- <Enter> Press <Enter> to accept the setpoint value and move to the next alarm function.

4.6.14 The Range Function

The RANGE function allows you to:

- MANUAL or AUTO: Manually (MANUAL) or automatically (AUTO) select the concentration range of analysis.
- DGTL: Use the 24 VDC remote zero and remote span inputs to select the range.

In the MANUAL screen, you are further allowed to define the low (concentration) limits of each range, and select a single, fixed range to run.

CAUTION: IF THIS IS A LINEARIZED APPLICATION, THE NEW RANGE MUST BE WITHIN THE LIMITS PROGRAMMED USING THE LINEARIZATION FUNCTION, IF LINEARIZATION IS TO APPLY



THROUGHOUT THE RANGE. FURTHERMORE, IF THE LIMITS ARE TOO SMALL A FRACTION OF THE ORIGINALLY LINEARIZED RANGE (APPROX 10 % OR LESS), THE LINEARIZATION WILL BE COMPROMISED.

4.6.14.1 MANUAL (SELECT/DEFINE RANGE) SCREEN

The Manual range-switching mode allows you to select a single, fixed analysis range. It then allows you to redefine the upper and lower limits, for the range. To enter a MANUAL or fixed range:

<▲ ▼> Scroll to the Range function using the UP/DOWN keys.

<Enter> Press <Enter> to activate the RANGE function.



-> Range Select: Auto
Man Rng: R1

<Enter> Press <Enter> again to move to the Auto/MAN field.

<▲ ▼> Use the <▲ ▼> keys to toggle between Auto and Manual.

<Enter> Press <Enter> when Man is displayed on screen.

The next screen prompts you to select a range: R1, R2 or R3.



-> Man Rng: R1
R1: 0- 1.00 ppm

<Enter> Press <Enter> to highlight the Range field.

<▲ ▼> Use the UP/DOWN keys to choose R1, R2 or R3.

<Enter> Press <Enter> to accept the displayed range. The arrow will move to the line for defining that particular range. If you don't need to adjust the range setting, <Escape> back to the *Analyze Mode* and note that it is using the fixed range you entered.

If you need to alter the range setting:



Man Rng: R1
->R1: 0- 1.00 ppm

- <Enter> Use the <Enter> key to move to the value you want to change to define the range you want to work with.
- <▲ ▼> Use the UP/DOWN keys to cycle the numbers up or down for each digit.
- <Enter> Use the <enter> key to move to the next character placeholder in the number field.
- <Enter> When the last digit has been entered, press <Enter> again to accept the value or <Escape> to abort the numerical entry.

This same procedure is used to select and define all ranges.

4.6.14.2 AUTO RANGE

Rather than defining a specific range to work in, you can set the instrument for autoranging. In the autoranging mode, the microprocessor automatically responds to concentration changes by switching ranges for optimum readout sensitivity. If the upper limit of the operating range is reached, the instrument automatically shifts to the next higher range. If the concentration falls to below 90% of full scale of the next lower range, the instrument switches to the lower range. A corresponding shift in the DC concentration output, and in the range ID outputs, will be noticed.

Note: As required by the autoranging software, R1, R2 and R3 must be defined and be linearly increasing, which means $R1 < R2 < R3$.

The autoranging feature can be overridden so that analog output stays on a fixed range regardless of the contaminant concentration detected. If the concentration exceeds the upper limit of the range, the DC output will track until it saturates at 110 % of full scale, in other words: 1.1 V or 21.6 mA using the current output.

However, the digital readout and the RS-232 output of the concentration are unaffected by the fixed range. They continue to read beyond the full-scale setting until amplifier saturation is reached. Below

amplifier saturation, the over range readings are accurate UNLESS the application uses linearization over the selected range.

To setup automatic ranging:

<▲ ▼> Scroll to the Range function using the UP/DOWN keys.

<Enter> Press <Enter> to activate the RANGE function.



<Enter> Press <Enter> again to move to the Auto/MAN field.

<▲ ▼> Use the <▲ ▼> keys to toggle between Auto and Manual.

<Enter> Press <Enter> when Auto is displayed on screen.
This sets the instrument in the Autoranging mode.

<Escape> Use Escape to move back to the Analyze Mode. Note that the analyzer will now automatically switch analysis ranges as the concentration rises above or below the range limits.

4.6.14.3 DIGITAL MODE

The digital mode (DGTL) for range selection uses the remote zero and span inputs to select the range according to Table 4-1.

Note: The remote calibration feature (remote zero and remote span) will be inoperable when the instrument is set for digital range selection. Placing the instrument back into either manual range selection or autoranging will reestablish the functioning of the remote calibration feature.

Table 4-1: Digital Range Selection Signals

Contacts		
Zero	Span	Range
Low	Low	Autorange mode

Low	High	R3
High	Low	R2
High	High	R1

To use the digital input range selection:

<▲ ▼> Scroll to the Range function using the UP/DOWN keys.

<Enter> Press <Enter> to activate the RANGE function.

->Range Select: Dgtl
Man Rng: R1

<Enter> Press <Enter> again to move to the **dgtl** field.

<▲ ▼> Use the <▲ ▼> keys to toggle between the Auto, Manual and Digital modes

<Enter> Press <Enter> when **Dgtl** is displayed on screen.

This sets the instrument in the Digital mode.

<Escape> Use Escape to move back to the Analyze Mode. Note that the analyzer will now switch analysis ranges according to the inputs from the remote zero and span ports.

*Note: When the instrument is operating in this mode, the remote zero and span inputs will **not** trigger a calibration event.*

4.6.15 Digital Filter Setup

The Model 4020 analyzer has the option of decreasing or increasing the amount of filtering on the detector signal. This feature enhances the basic filtering done by the analog circuits by setting the amount of digital filtering applied by the microprocessor. The digital filter setup function is accessed from the MAIN MENU. To set the amount of digital filtering:

<▲ ▼> From the MAIN MENU, scroll to the FILTER function using the UP/DOWN keys.



RANGE
-> FILTER

<Enter> Press <Enter> to activate the FILTER function.



Digital Filter
-> Index: 4

<Enter> Press <Enter> again to move to the Filter index field.

<▲ ▼> Use the UP/DOWN keys to increment or decrement the amount of filtering to be applied by the microprocessor.

This index can be adjusted from 0, minimum digital filtering, to 7, maximum digital filtering. The default setting is 4 and that should suffice for most applications. In some applications where speeding the response time with some trade off in noise is of value, decrease the value for the digital filter. In applications where the signal is noisy, increase the value. Decreasing the digital filter index will result in a slower response time.

4.6.16 Fuel Display

This screen displays the fuel type this instrument is set up for: 40%H₂/60%N₂, or 100% H₂, or 100%N₂. It is an information only screen and has no bearing on the analyzer performance.

4.6.17 Valve Selections

This 4020 analyzer has the option of 3 input streams. The rear panel of the analyzer has 3 gas inputs labeled: "SAMPLE", "SPAN" and "ZERO".

The particular gas stream sent to the analyzer can be determined in one of three ways:

1. Valve selection disabled. This option has the "SAMPLE" valve always open, typically to deliver sample gas to the analyzer.

2. User Select . The user can select which port opens to the analyzer.
3. By Function: In this option, a specific gas port opens to the analyzer depending on the current mode of the analyzer. For instance, when performing a zero calibration, the “ZERO” port would be open while “SAMPLE” and “SPAN” ports would be closed.

To enable/disable or select a specific valve selection mode:

<▲▼> From the MAIN MENU, scroll to the VALVE SELECTIONS function using the UP/DOWN keys.

<Enter> Press <Enter> to bring up the valve selection setup screen.

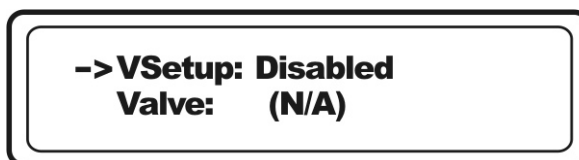

<▲▼> Use the <▲▼> keys to toggle between the Disabled, User Select and Default (by Function) modes.

<Enter> Press <Enter> when the appropriate function is displayed on screen.

<Escape> Use Escape to move back to the Analyze Mode. Note that the analyzer will now switch gas to the analyzer depending on the choice shown on screen as detailed below.

4.6.17.1 DISABLED

When the valve selection mode “Disabled” is selected, the gas connected to the sample port will be fed to the analyzer, i.e. the “SAMPLE” port will always be open as the default stream fed to the analyzer. During all modes of operation (Analyze, Span, or Zero), the valve position will not be indicated on the screen as shown below.

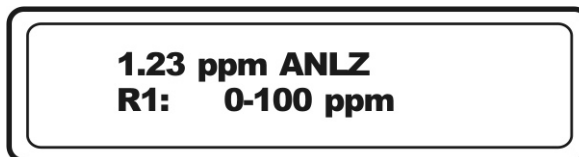

or

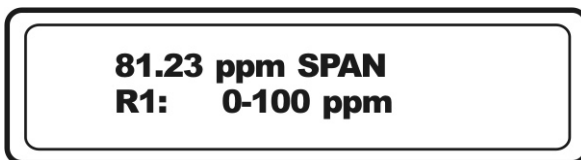

81.23 ppm SPAN
R1: 0-100 ppm

and so forth for the zero mode.

4.6.17.2 USER SELECT

This option of valve selection allows the user to determine the particular gas stream sent to the analyzer. Note that the valve selected will be open during ALL modes of the instrument operation (Analyze, Span and Zero).

There are three choices within the User Select option corresponding to the valve the user elects to be open to the analyzer (Sample, Span or Zero). The second line of the display will indicate the current valve selection.

To select the valve to be opened to the analyzer:

- <▲▼> From the VALVE SELECTIONS menu, Use the <▲▼> keys to toggle the option to USER SELECT
- <Enter> Press <Enter> to bring up the USER SELECT screen.



->VSetup: User Select
Valve: Always SAMPV

- ▲▼> Use the <▲▼> keys to toggle between the options of:
“ALWAYS SAMPV” (sample valve)
“ALWAYS SPAN” (span valve)
“ALWAYS ZERO” (zero valve)
- <Enter> Press <Enter> when the appropriate valve selection is displayed on screen.
- <Escape> Use Escape to move back to the Analyze Mode. Note that the analyzer will now switch gas to the analyzer from the selected port regardless of whether the analyzer is in analyze or calibration mode.

As an example of the display in *Analyze mode* when USER SELECT is the current valve selection mode and “Always SAMPLE” valve is chosen, the display will be as follows:

1.23 ppm ANLZ SAMPV
R1: 0-100 ppm

or when in SPAN mode:

81.23 ppm SPAN SAMPV
R1: 0-100 ppm

4.6.17.3 DEFAULT (BY FUNCTION)

In the default mode of valve selection, the specific valve that is open to the analyzer depends on whether the analyzer is in *Analysis mode* or is in a calibration mode. If it is in Analysis mode, the “SAMPLE” valve is open to the analyzer. If it is in a calibration mode then either the “SPAN” or ZERO” valve will be open to the analyzer.

To switch to the default mode of valve operation:

<▲▼> From the VALVE SELECTIONS menu, Use the <▲▼> keys to toggle the option to default

<Enter> Press <Enter> to bring up the valve selection default screen.

->VSetup: Default
Valve: By Function

▲▼> Use the <▲▼> keys to toggle to the “DEFAULT” option.

<Enter> Press <Enter> when “DEFAULT” is displayed on screen.

<Escape> Use Escape to move back to the Analyze Mode. Note that the analyzer will now switch either sample or calibration

gas (zero or span) to the analyzer depending on the function of the analyzer, whether it is analyzing a sample gas or calibrating.

During analysis, the screen will display as:

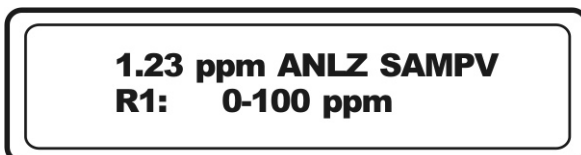

1.23 ppm ANLZ SAMPV
R1: 0-100 ppm

While in span calibration, the screen will display as:

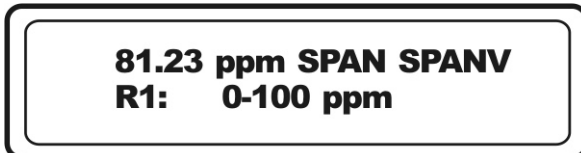

81.23 ppm SPAN SPANV
R1: 0-100 ppm

with a similar display for a zero calibration except the zero valve will be indicated as open (“ZERO ZEROV”).

4.6.17.4 OBSERVING THE GAS STREAM CONCENTRATIONS

The actual gas concentrations of the gas streams can be observed using two different methods:

1. Use the USER SELECT option of the VALVE SELECTIONS menu and choose the appropriate valve to open from the second line of the display. Then return to *Analysis* mode by repeatedly pressing <Escape> and observe the concentration of that stream on the display.

Note: With this technique, the alarms are not suppressed and depending on the gas and the alarm setpoint, it could trigger an alarm.

2. Use the DEFAULT option of the VALVE SELECTIONS menu and select the SPAN (or ZERO) function from the MAIN MENU. With the SPAN (or ZERO) function selected, select MANUAL FINISH from the first line of the display on the SPAN or ZERO submenu. The display will show:



Span Manual Finish
Span 80.00 ppm

Or



Zero Manual Finish
Zero 0.00 ppm

Note: The actual displayed concentration may be different depending on your calibration gas.

Then begin the span or zero routine and observe the concentration on the screen. Since the analyzer is in a calibration mode, the alarms will be suppressed.

Note: Make sure you reset the valve selection to the desired mode after completion of either of these procedures.

4.6.18 Standby

This function allows you to place the instrument in STANDBY.

CAUTION: STANDBY SHUTS DOWN POWER TO THE DISPLAYS ONLY. INTERNAL CIRCUITS ARE STILL ENERGIZED AND ELECTRICAL SHOCK HAZARD STILL EXISTS.



To place the instrument in STANDBY status:

- <▲▼> From the MAIN MENU, scroll to the STANDBY function using the UP/DOWN keys.
- <Enter> Pressing <Enter> places the instrument in STANDBY.
To exit STANDBY, scroll again to the STANDBY function and press <Enter> again.

4.7 Advanced User Functions

The Model 4020 provides additional functions for tailoring the instrument to your specific application. These functions include:

- Analog Adjust
- Linearization
- Background Gas Selection

4.7.1 Zero Offset Adjustment

The software in this instrument provides a way to enter an offset to the zero of the analyzer. This may be useful if, for example, the zero gas is not pure and it contains some hydrocarbon. In this case, the reading will have an offset that will be constant throughout its working range. Thus, by entering an initial offset to the output (either current or voltage), the display will match the output over the range of the application.

Note: This adjustment only affects the % of range output of Channel 1.

To access the offset function:

- <▲ ▼> From the MAIN MENU, scroll to the ANALOG ADJUST function using the UP/DOWN keys.
- <Enter> Pressing <Enter> activates the function and takes you to the next screen.



->4-20 mA Offset: -25
4-20 mA Gain: 117

- <Enter> Use the <Enter> key to move over to the Offset field.
- <▲ ▼> Use the UP/DOWN keys to change each digit's value.
- <Enter> Use the <Enter> key to accept a digit and move to the next character position. The final enter will accept the value and move the arrow to the function which allows you to set the gain.

Use the same procedure to set the gain of the instrument. After the last digit is entered, the final <Enter> press will accept the gain value.

The value you enter for the offset to zero or gain will be automatically added to the reading. Thus, if you entered -0.10 for zero offset, the display will show -0.10 for zero concentration.

During calibration, when the instrument enters the zero mode in AUTO, the instrument will do the work of bringing the reading back to zero plus the offset value that was entered. If you chose MANUAL zero mode, then you must adjust the zero of the instrument to read zero plus the value entered as offset.

4.7.2 Background Gas Selection

The 4020 Analyzer can be used to analyze sample gas in a background of either O₂ or N₂. This menu is used to inform the instrument which background gas is being used. The analyzer will then apply the proper calibration parameters to the measurement process.

Note: Separate zero and span calibrations must have been performed prior to using selected sample/background gas for analysis.

To select a background gas:

- <▲ ▼> From the MAIN MENU, scroll to the BACKGROUND GAS function using the UP/DOWN keys.
- <Enter> Pressing <Enter> activates the function and takes you to the next screen.

-> Background Gas: O2

- <Enter> Use the <Enter> key to move over to the gas field (O₂ or N₂).
- <▲ ▼> Use the UP/DOWN keys to toggle between the two options..
- <Enter> Use the <Enter> key to accept the appropriate background gas when it is displayed.

Maintenance & Troubleshooting

WARNING: *DANGEROUS HIGH VOLTAGES EXIST INSIDE THIS INSTRUMENT.*



THERE ARE NO USER SERVICEABLE PARTS WITHIN THE COVER ON THE INSIDE OF THE DOOR, INSIDE THE ISOTHERMAL CHAMBER, (SAMPLE SYSTEM), AND ON THE ELECTROMETER-AMPLIFIER PC BOARD. WORK IN THESE AREAS MUST BE PERFORMED BY AUTHORIZED AND TRAINED PERSONNEL ONLY.

BEFORE STARTING ANY OF THESE MAINTENANCE AND TROUBLESHOOTING PROCEDURES, READ THE CAUTIONS AND WARNINGS INCLUDED IN THE SECTION TITLED "ADDITIONAL SAFETY WARNINGS". PAY SPECIFIC ATTENTION TO THE PROCEDURES FOR REMOVAL OF INTERNAL INACCESSIBLE SHOCK HAZARDS. IF THE INSTRUMENT MUST BE TURNED ON DURING ANY OF THESE MAINTENANCE AND TROUBLESHOOTING PROCEDURES, BE CAREFUL AND WORK WITH THE ONE HAND RULE:

Work with one hand only.

Keep the other hand free without contacting any other object. This reduces the possibility of a ground path through the body in case of accidental contact with hazardous voltages.

CAUTION: *MANY OF THE ELECTRICAL PARTS WITHIN THE MODEL 4020 ARE SUSCEPTIBLE TO DAMAGE FROM ELECTROSTATIC DISCHARGE (ESD). USE ESD SAFE PROCEDURES WHEN HANDLING OR WORKING WITH ELECTRONIC COMPONENTS.*



If the analyzer is suspected of incorrect operation, always evaluate performance with zero or span gas flowing in the sample path. Never

attempt to evaluate performance on sample gas. If analyzer sensitivity is questionable, use the span gas. For all other evaluations, use the zero gas and low range for maximum sensitivity. The important consideration is to control as many variables as possible. Using cylinder-supplied gases of known hydrocarbon content eliminates the possibility of introducing an unknown variable.

Do not overlook the seemingly obvious. Check to see that power is available for the instrument (and of the proper voltage, etc.), and that connections are correct. Also verify that support/calibration gases are not depleted.

5.1 Measuring Circuit Electrical Checks

If the analyzer performs erratically on zero gas, the trouble can be related to either the integral gas control systems, or the electronics. To isolate the problem, the two systems must be separated. To isolate the electronics, employ the following procedure:

1. Pull analyzer out of the drawer, remove sample system top cover, remove and disconnect the collector cable from the sensor leaving it attached to the electrometer board. (Consult schematic and assembly drawings for circuitry and location). With this cable disconnected, the electronic circuitry is completely isolated from the gas control system and cell.
2. Select the auto measurement range (for maximum sensitivity) and adjust the zero offset value until the readout device indicates above midscale. (The span control should already be set)

5.1.1 Loss of Zero Control

If the zero cannot be controlled as directed above, a failure has occurred in either the power supply or the electrometer-amplifier. Use the following procedure to isolate the fault:

With a digital voltmeter (DVM) set to read 15 VDC, check the positive and negative 15 V output of the power supply as follows:

(See schematic D65506 drawing of assembly PCB C65507A for power supply PC board).

1. Connect the voltmeter leads across tantalum capacitor C1. Note the positive polarity is marked on the PCB silkscreen. The measured voltage should be 15 ± 1 volt.

2. Then connect the DVM leads across tantalum capacitor C3. Note the positive polarity is marked on the PCB. The Plus side connects to ground. Measured voltage should be -15 ± 1 volt.

If correct readings are not obtained at both points, power supply has failed, and that printed circuit card must be replaced. If correct readings are noted, the electrometer-amplifier has failed, and that printed circuit card must be replaced.

Note: TAI recommends that spares for each of the printed circuits be kept on hand so that service can be restored immediately. The faulty circuit card can be returned to the factory for repair. Unless personnel knowledgeable in electronics are available, do not tamper with the circuits.

5.1.2 Anode Voltage Check

If the output can be adjusted by the zero control (the above section, step 2), the cell anode voltage should be verified as follows:

WARNING: **THESE PROCEDURES SHOULD BE CARRIED OUT ONLY BY PERSONNEL FAMILIAR WITH HIGH VOLTAGE CIRCUIT BOARDS. THE ANODE-IGNITER UNIT AND ASSOCIATE CIRCUITRY INVOLVE DANGEROUSLY HIGH VOLTAGES.**



Refer to the cell wiring diagram. Using a voltmeter set to measure 125 VDC, check the voltage on either of the anode-igniter electrodes, as follows:

1. Connect the **negative** voltmeter lead to ground and the **positive** lead to either electrode. Be careful not to short the circuit by touching both an electrode and the cell body simultaneously. The reading obtained should be 125 ± 10 VDC.
2. If no reading is obtained, disconnect the anode-igniter cable and check for the voltage on pin "J4-1" of the connector located at PC board part number B74671. If the proper voltage is still not present, replace the flame guard and anode power supply PC board. If it is, check the wiring in the anode-igniter cable plug. If necessary, the circuit board can be replaced by first turning off the power, then removing 4 screws holding the board.

WARNING: *DO NOT TOUCH CAPACITOR C1 OR C2 OR THEIR RELATED CIRCUIT FOILS. A SHOCK HAZARD MAY EXIST.*



Carefully remove the circuit board without touching any connections which might lead to C1 or C2. After removal, discharge the two capacitors by placing a jumper wire across each.

3. The anode voltage may also disappear or be greatly diminished when condensation inside the sensor has occurred, shorting the igniter to the sensor body across the wet insulator. This usually occurs when the flame is turned on, if the sensor has not been preheated for at least 1 hour.

5.1.3 Electronic Stability

If the checks outlined above indicate that conditions are normal, allow the analyzer to run electronically with the collector cable disconnected for several hours in the lowest range, and with the zero offset value adjusted so that the recorder is reading midscale. If all is normal electronically, a noise-free (pen width) recording, showing absolutely no instability, should be obtained for as long as the analyzer is allowed to run in this configuration. If the recording obtained is noisy or erratic, replace the electrometer-amplifier PC board.

5.1.4 Printed Circuit Board Replacement

If performance is not adequate, then the analyzer must be recalibrated as described in Section 4.6.15: *Calibration* before being placed back in service.

Whenever the flame guard and anode power supply printed circuit board have been replaced the analyzer must be recalibrated.

If the instrument performs as outlined in this section, the problem is not related to the measuring circuit electronics.

5.1.5 Collector Cable

Before reconnecting the collector cable, check the continuity of the center wire of the cable with an ohmmeter by measuring between the center pins at each plug on the lowest resistance scale of the meter. Flex the cable while making this measurement to be sure that there is not an



intermittent open circuit. If there is, replace the cable. Do not attempt to repair the cable, as special tooling is required to disassemble and reassemble the cable plugs.

5.2 Temperature Control Electronic Check

If the heating circuit fails, the output of the analyzer will tend to drift with changes in ambient temperature. Such a failure will be more evident in the low range. If the temperature environment surrounding the analyzer is closely regulated, failure in this circuit might go unnoticed after the initial failure. If the environment follows day and night temperature changes, the analyzer will show a diurnal, bi-directional drift when operated on zero gas. The magnitude of the drift will be a function of the temperature differential experienced by the analyzer. To check the circuit, employ the following procedure:

Consult the 4020 schematic and assembly drawings, as well as the temperature control PC board schematic and assembly drawings at the rear of the manual for circuit details and component placement.

An indicator light on the control panel cycles on and off with the heating element; the light is on when the heater is on, and vice versa. Failure of the light to come on at all when the cell compartment is cold indicates a problem in the temperature sensing or control circuitry or the wiring that interconnects the thermistor to the circuit. If the light stays on constantly, but the compartment does not heat up, then a problem with the heating element or connecting wiring is indicated.

1. Check the sensing type K thermocouple by measuring the resistance between its connecting wires. Disconnect one of the thermocouple wires from terminal strip on the temperature controller, P/N CP02408, the wires out of the thermocouple are yellow (+) and red (-), and measure resistance between that wire and the remaining undisturbed terminal. Resistance of the thermocouple varies with its surrounding temperature. A reading of between 3 Ohms and 25 Ohms (not a short or open) at around 25 °C (77 °F) may be measured. If the thermocouple measures anywhere in this range, it is most likely OK. Otherwise, if the circuit is short or open, check the wires leading to the thermocouple or the thermocouple maybe bad,
2. Check the heating element by measuring its resistance. Disconnect one of the heater wires from either terminal 2 or terminal 4 on the temperature control board P/N CP02408, heater

wires are black, and check the resistance between that wire and the remaining undisturbed terminal. If a reading of approximately 100 Ohms, then the heating element is most likely OK. If an open circuit is found, check the heater wires and a possible connector between the heater and temperature control board. If no problems are found, and the heater circuit is open, then replace the heater element.

Note: If any of the components located inside the isothermal chamber has failed, the instrument must be removed for service. If no problems are found with either the thermistor or the heater circuits, then replace the temperature control board.

5.3 Ignition and/or Flame Guard Circuit Checks

If the flame guard circuit will not hold the flame-out lamp off when the ignition procedure is employed (see section 4.5 *Flame Ignition*), perform the following procedure to isolate the problem (consult the system schematic for details of the circuit):

1. Disconnect the anode-igniter/flame guard thermistor cable from the socket.
2. Check the flame guard sensing thermistor by measuring the resistance between pins J4-3 & 4 of PCB part number B74671, disconnect the cable plug. The reading should be about 100 K Ω at room temperature. The actual resistance is not important, since the thermistor experiences radical changes in resistance as the temperature changes. No indication in a sufficiently high range on the ohmmeter indicates an open thermistor. (If the thermistor is hot, the resistance will be much lower.)
3. Check the anode-igniter coil for continuity by measuring between pins J4-1 & 2 of the disconnected cable plug. The ohmmeter should indicate a short circuit.
4. If either step 2 or 3 does not check as indicated, remove the electrode assembly of the detection cell and replace it. If the quartz flame tip is damaged, the top section of the cell may be removed by disconnecting the vent line, and removing the screws around its flange. Return the unit complete with attached electrode cable. If steps 2 and 3 both check out properly, reconnect the anode-igniter cable.



5. Check K1 and K2 relays operation as the analyzer is RE-IGNITING. If the relays do not energize, remove the flame guard power supply board and check the forward and backward resistance of its transient suppression diode by measuring across CR4 and CR5. The ohmmeter should indicate some resistance. If the indication is a short circuit, then the diode must be replaced.

Note: If, after replacing a defective diode, the circuit still does not work properly, the flame guard circuit components have been damaged, and the PC board must be replaced.

6. If the preceding steps check out correctly, the flame guard portion of the circuitry on the flame guard/anode power supply PC board is defective.

IMPORTANT: If the circuit proves defective, the analyzer will have to be recalibrated after the board is replaced.

5.4 Sampling System

If the procedures outlined above do not correct the problem, the fault must be related to the gas control systems. Plugged or faulty regulators, plugged restrictors, or leaks within the system can cause erratic performance. TAI recommends that the factory or an authorized representative be contacted before attempting any repairs to the sample or supporting gas systems within the analyzer.

5.5 Printed Circuit Board Descriptions

The electronic circuitry of the analyzer is designed with the latest integrated circuit technology. The individual circuits which are required to process the incoming signal and condition it to provide the various outputs, alarms, indicators, etc.,

5.5.1 Flame Guard and Anode Power Supply PCB

Schematic No. B-74672

Assembly Dwg. No. B-74671

Anode Power Supply: The high voltage anode power supply components are mounted on the flame guard and anode power supply printed circuit board. High voltage regulation is achieved through the

use of zener diodes. The simplicity of this circuit's design can be attributed to the extremely low current demand of the anode circuit. The positive output voltage is nominally 125 volts. Output tolerance is ± 10 volts from the specified 250 volts, due to variation in components from unit to unit.

Flame Guard Circuit: A thermistor-controlled, comparator circuit is employed to operate relays in the event of a flame-out condition. A panel indicator light is turned on by the relay to alarm personnel that a flame-out condition has occurred.

The controlling thermistor is located within the upper section of the cell assembly. The electronic circuit components and relays are mounted on the same printed circuit board as the anode power supply. The indicator light is on the control panel.

The thermistor is located in the circuit so that it controls the input of the comparator. The circuit is factory set so that with the flame burning, the output of the comparator is low. The microprocessor senses the low input and in turn sends 5VDC to turn on Q1, this holds the relay energized. When energized, the relay extinguishes the Flame Out indicator light. Conversely, if the flame goes out, bias to the switching transistor is lost, the relay drops out, and the Flame Out light receives power through normally closed contacts.

During ignition, the flame heats the thermistor, holding the relay in the energized condition and the indicator light off. If the Flame Out light comes on as the analyzer returns to analyzing mode, then the flame is not burning, and the ignition procedure must be repeated.

5.5.3 Proportional Temperature Controller PCB

Schematic No. B-31077

Assembly Dwg. No. B-30927

The temperature of the chamber to be controlled is regulated by a thermistor-directed electronic circuit. The thermistor and heating element are located in the chamber, and the balance of the circuit components are mounted on the temperature controller printed circuit board, which plugs into a connector on the motherboard.

The control temperature is determined by the value of resistor R3 and C3 on the temperature controller printed circuit board, selected (at the time of manufacture) from the chart on schematic B-31077 to provide the desired control point.



The thermistor used in the circuit is a negative temperature coefficient (NTC) device; as the chamber temperature increases, the resistance of the thermistor decreases, and vice versa.

The resistance of the thermistor in the circuit is compared with the value of resistor R3; when their resistance is equal, or when the resistance of R3 is less than that of the thermistor, the heating circuit is activated.

When a temperature deficiency is sensed by the thermistor, integrated circuit A1, acting as a zero-crossing switch, applies a pulsed signal to triac Q1, which in turn applies full wave power to the heating element.

IC A1 employs a diode limiter, a zero-crossing (threshold) detector, an on-off sensing amplifier (differential comparator), and a Darlington output driver (thyristor gating circuit) to provide the basic switching action. The DC operating voltages for these stages are provided by an internal power supply, with only capacitor C4 added externally.

The on-off sensing amplifier in this circuit is configured as a free-running multivibrator. This scheme adds proportional control, which takes over when the comparator inputs are at the design differential voltage.

Initially, when cold, the thermistor resistance is large, and the voltage at pin 7 is larger than that at pin 8. As the temperature of the controlled chamber begins to rise, the resistance of the thermistor decreases, thus reducing the voltage at pin 8. During this warm-up time the thyristor gating circuit is continuously delivering gate current from pin 4 of A1, thus maintaining constant fullwave AC power to the heater.

When the temperature reaches the selected control point, pin 13 voltage is about the same as pin 9 voltage, and proportional control takes over. The rate at which thyristor (triac) Q1 conducts and allows power to be delivered to the heater is determined by the combination of components R2 & R3, R4, C3, R5, and the thermistor resistance at the control temperature. Consequently, the balance point of the bridge formed by this combination of components can be altered by the selection of R3, causing the circuit to seek a temperature at which the thermistor resistance balances the bridge.

Because IC A1 triggers the thyristor at zero-voltage points in the supply voltage cycle, transient load current surges and radio frequency interference (RFI) are substantially reduced. In addition, use of the zero-

voltage-switch reduces the rate of change of on-state current (di/dt) in the thyristor.

5.5.4 Electrometer-Amplifier PCB

Schematic No. B79159

Assembly Dwg. No. B79153

The ions formed in the process of burning hydrogen in the presence of hydrocarbon components of the sample gas cause an electrical conduction between two electrodes in the combustion chamber (or detector cell) that is amplified by a high sensitivity and high input impedance electrometer-amplifier circuit. The electrical output of the electrometer-amplifier is directly proportional to the quantity of flame ionizable hydrocarbons present.

The electrometer amplifier PC board is located on the side of sample module, interconnected to the electronic circuitry by means of a single 8 pins cable, so that the ease of replacement of a board is maintained. The high input impedance requires a shield, or cover, which is removable for access, as well as a shielded input conductor. Interconnection with the collector is made by a coaxial cable.

Although the cable and fittings are intended for coaxial service, the cable is actually being used as a shielded single-conductor connection. The collector cable plugs into a coaxial connector on the electrometer amplifier PC board, which is located at the side of the sample module.

The circuit consists of an electrometer amplifier and an operational amplifier. It is a very high-gain, current-to-voltage converter circuit, having an input impedance measuring in the billions of ohms. It is static sensitive and highly susceptible to contamination, and special handling precautions must be taken.

Because of its high impedance, the input circuitry to the electrometer has had careful design consideration. The resistors (R2 and R3) in the input gain circuit (see schematic) are installed on Teflon-insulated standoffs, instead of directly to the printed circuit, to eliminate the possibility of leakage currents.

To eliminate any possibility of contamination of the insulating materials employed, the completed PC board is ultrasonically cleaned in laboratory grade alcohol. **Under no circumstances should the parts described be handled with bare fingers.** A freshly-scrubbed finger,

stroked along one of the glass resistors, would deposit enough skin oil to completely upset the range division of the attenuator circuit.

Resistor R3 is a 1000 M Ω resistor used in the feedback circuit of the amplifier. R2 has a resistance of 10,000 MW and is used in series with the zero potentiometer slider. This circuit is used to nullify any offset signal introduced by the signal electrode. Trimmer P1 is used to nullify the offset signal generated by the electrometer amplifier.

The output of the circuit is standardized against gases with known hydrocarbon concentrations by zero and span calibration, so that the meter and/or recorder indicates the hydrocarbon concentration of the gas being used.

The positive and negative operating voltage required by the electrometer amplifier is furnished by a switching power supply circuit, mounting at the back panel of the analyzer

The stability of the electrometer circuit can be tested as follows:

1. Disconnect the collector cable.
2. Place the analyzer in the auto range.
3. Adjust zero offset value so that the recorder reads at some point upscale, and record a 24 hour chart.

Appendix

Specifications

Fuel: Per application:

- Mixture of 40% hydrogen, 60% nitrogen
- Hydrogen

Accuracy: 1% of full scale

Electronic response time: 90% within one minute

Noise: Less than $\pm 0.5\%$ of full scale

Drift: Less than 1% of full scale per day

Ranges: 3 ranges user defined from 0 ppm to 6% (methane equivalent)

Sensitivity: As low as 0-1 PPM methane equivalent full scale

Output: Linear signal; meter readout
0-1 VDC plus 4-20 mA analog output

Ambient temperature: 40 °F to 110 °F (5 °C to 43 °C)

Flow rate: 100-400 ml per minute of sample
100-200 ml per minute of fuel (200 cu. ft. cylinder lasts about 1 month)

Power requirement: 115 VAC, 60 Hz, single phase

Power consumption: 140 W maximum

Inlet Pressure rating: 10 psig [69 KPa] to 40 psig [276 KPa],
Preferred: 15 psig [103 KPa]

Dimensions: 8.75 " x 19 " x 15.5 " (H x W x D)
222 mm x 483 mm x 394 mm

Weight: 55 lbs.

Application Data

Model Number:

Serial Number:

Ranges Of Analysis:

Output Signal:

Start-Up Span Setting:

Control Panel Pressure Settings:

Comments:

Blanket Air:

Fuel:

Sample:

Bypass Flowrate: A minimum of **0.25 SCFH** is indicated on the integral flowmeter

Recommended Support Gases: The accessory gases should **all** be laboratory analyzed and certified as to their hydrocarbon content.

Blanket Air: Water pumped, hydrocarbon free, compressed air.

Zero Gas: Water pumped, hydrocarbon free (certified)

Span Gas: ppm methane in (certified)

The span gas contains a known amount of methane impurity. The span gas **must** be certified as to its methane equivalent impurity.

IMPORTANT: For the best possible results, zero and span gases that are representative of the parent (or background) gas should always be used.

This is particularly true in applications where the analyzer is being used to analyze a number of different samples with varying concentrations of oxygen. The geometry and temperature of the flame will be somewhat dependent on the oxygen content of the sample. Alterations in the flame configuration will lead to differences in output readings. For the best possible results, TAI recommends that zero and span gases representative of each of these samples be used to standardize the analyzer.



Recommended Spare Parts List

Qty.	P/N	Description
1	B74671A	PC Board, Flame Guard & Anode Power Supply
1	B79153A	PC Board, Electrometer-Amplifier
1	CP02408	PID Temperature Control
1	B79154	Sensor Assembly
1	C75825A	Microprocessor PC Board
1	CP2540	Coaxial Cable
1	C62371A	Display PCB Assy.
1	B74674A	Interface to Motherboard PCB Assy.
1	C65507A	Backpanel/Power Supply PCB Assy.
1	L00079	Lamp, Neon
5	F00010	Fuse, 2A (220V uses F9)
1	L00156	Lens, Red
1	L00154	LED, Red
1	T01403	Thermocouple Assembly

IMPORTANT: Orders for replacement parts should include the part number and the model and serial number of the system for which the parts are intended.

Send orders to:

TELEDYNE INSTRUMENTS

Analytical Instruments

16830 Chestnut Street
City of Industry, CA 91748

Telephone: (626) 934-1500
Fax: (626) 961-2538

Web: www.teledyne-ai.com
or your local representative.

Email: ask_tai@teledyne.com

Drawing List

D75508	Outline Diagram
B75509	Piping Diagram
B79159	Schematic, Electrometer PC board
B74672	Schematic, Flame Guard, Anode Power Supply PC Board
D65506	Schematic, Backpanel/Power Supply PC Board
D79161	Wiring Diagram, 19" Rack Standard

Assemblies

D79158	Assembly, Sensor
--------	------------------

PC Board Assemblies

B74671	PCB Assy, Anode Power Supply, Flame Guard
B79153	PCB Assy, Electrometer
C75825A	PCB Microprocessor
C65507A	PCB Power Supply

NOTES: UNLESS OTHERWISE SPECIFIED.

- ELECTRICAL CONNECTION:
STANDARD: 110 VAC, 50/60 Hz, 0.9 AMP, MAX FUSE USED: 250V, 1A, TYPE T
OPTIONAL: 220 VAC, 50/60 Hz, 0.9 AMP, MAX FUSE USED: 250V, 1A, TYPE T
- GAS CONNECTIONS:
1/8" TUBE FITTINGS: BYPASS, VENT, AIR INLET, SPAN
1/4" TUBE FITTING: SENSOR VENT
- INPUT/OUTPUT DATA CONNECTIONS:
RS 232: 9 PIN D SUB CONNECTOR
CONTROL DATA: 50 PIN D SUB CONNECTOR
- ALL DIMENSIONS ARE IN INCHES (MILLIMETER)
- OPTIONAL: AUTO-CAL MANIFOLD FEATURE
- INLET GASES:
A: PARTICULATE FREE
B: NON-CONDENSATING
C: 5-50°C

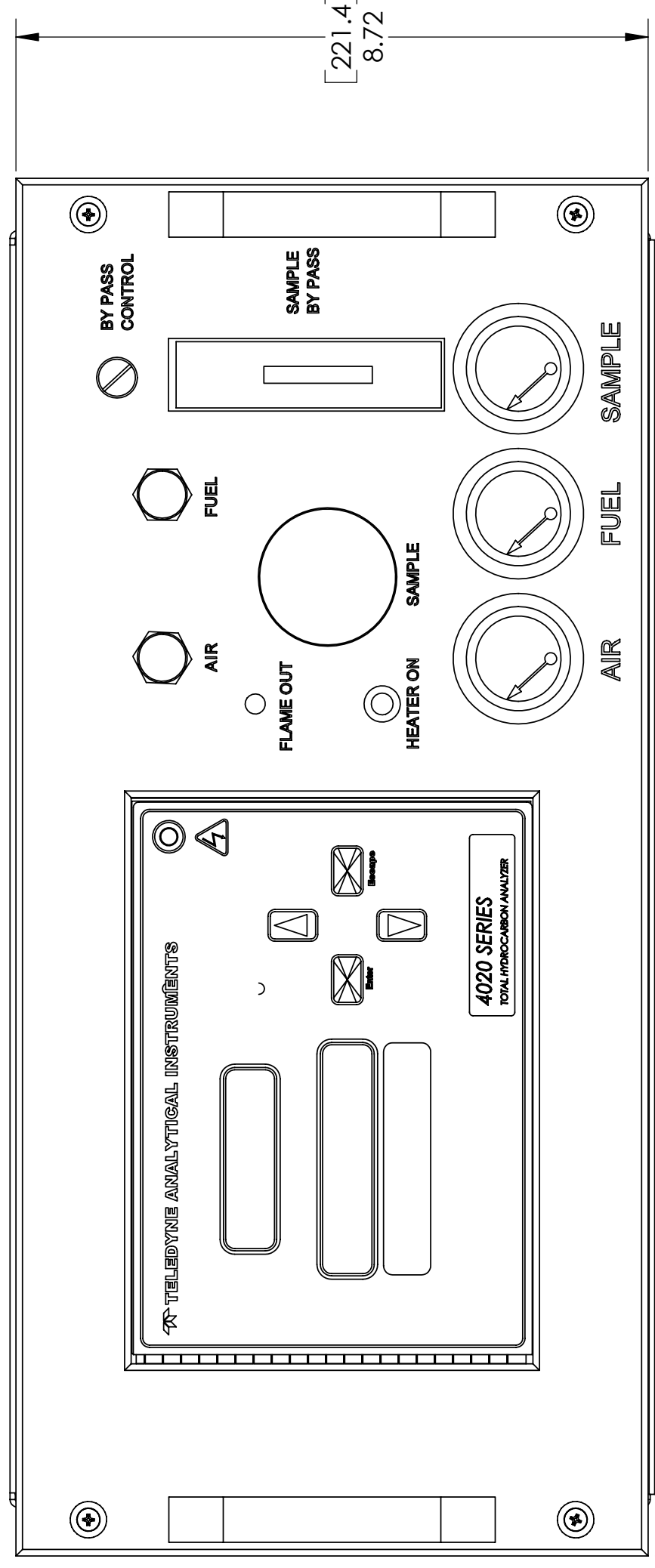

FRONT VIEW

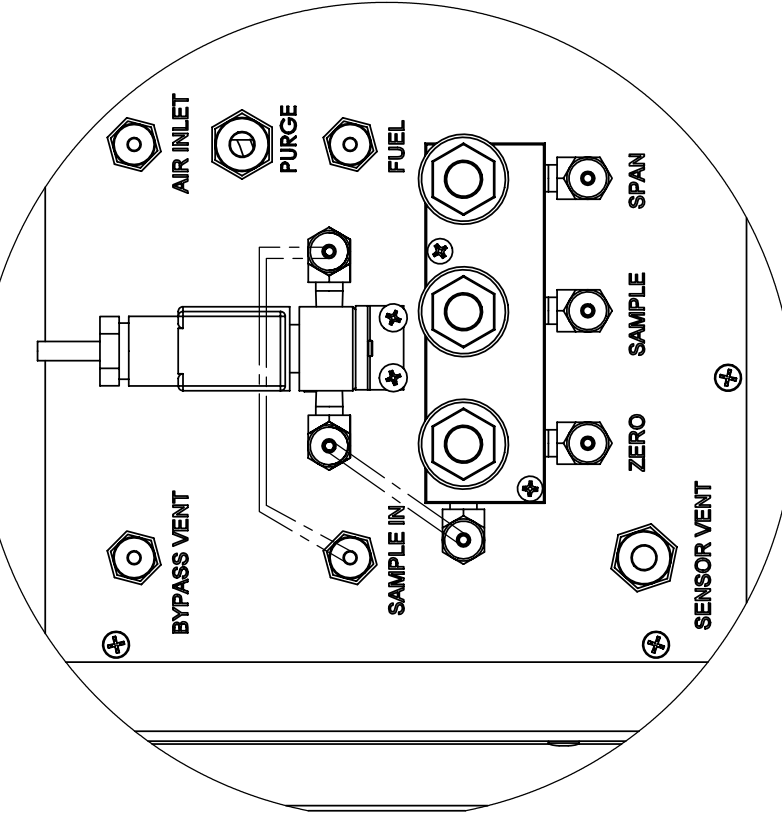

DETAIL A
FOR H2 GAS
BACKGROUND

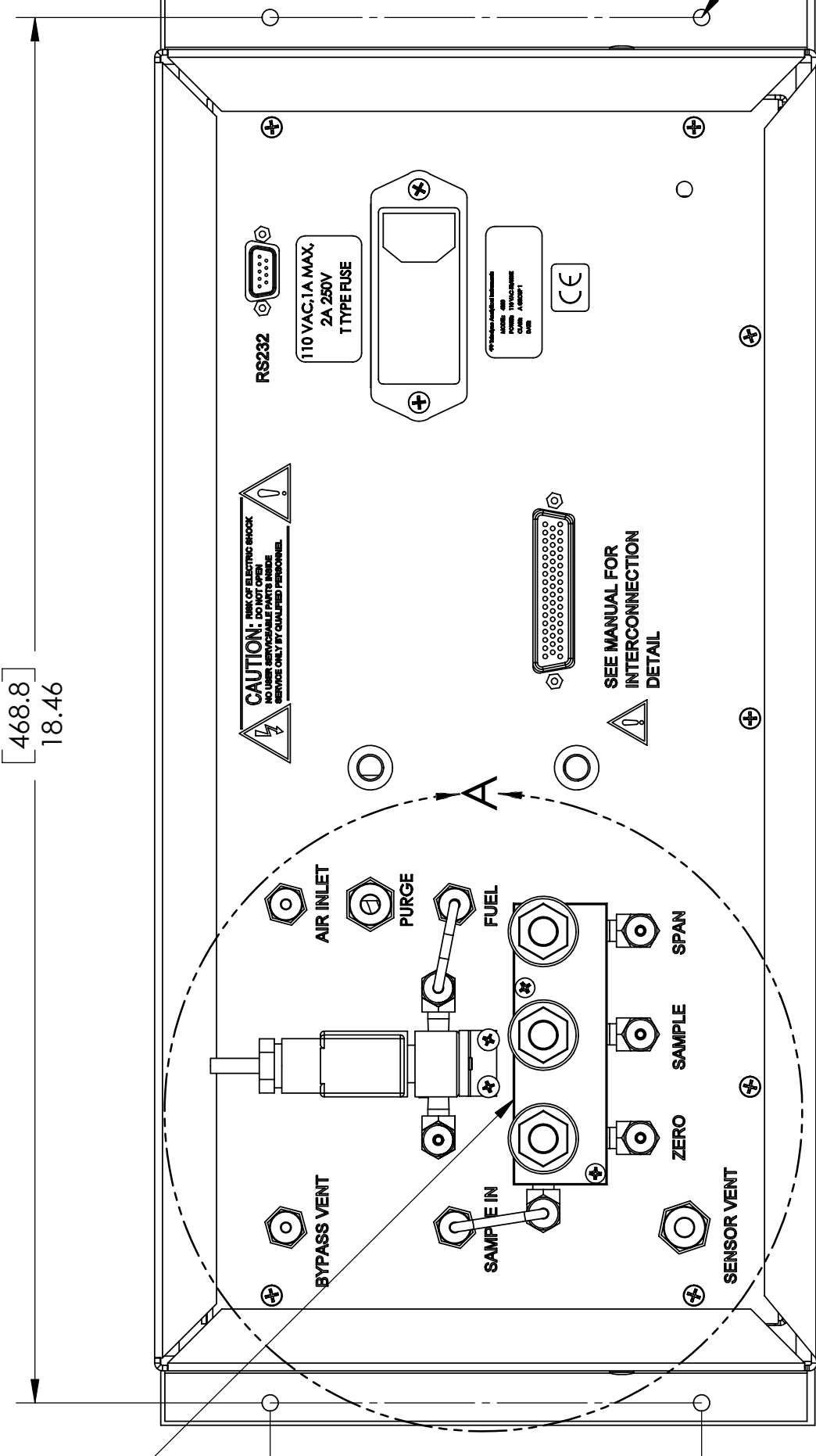

REAR VIEW

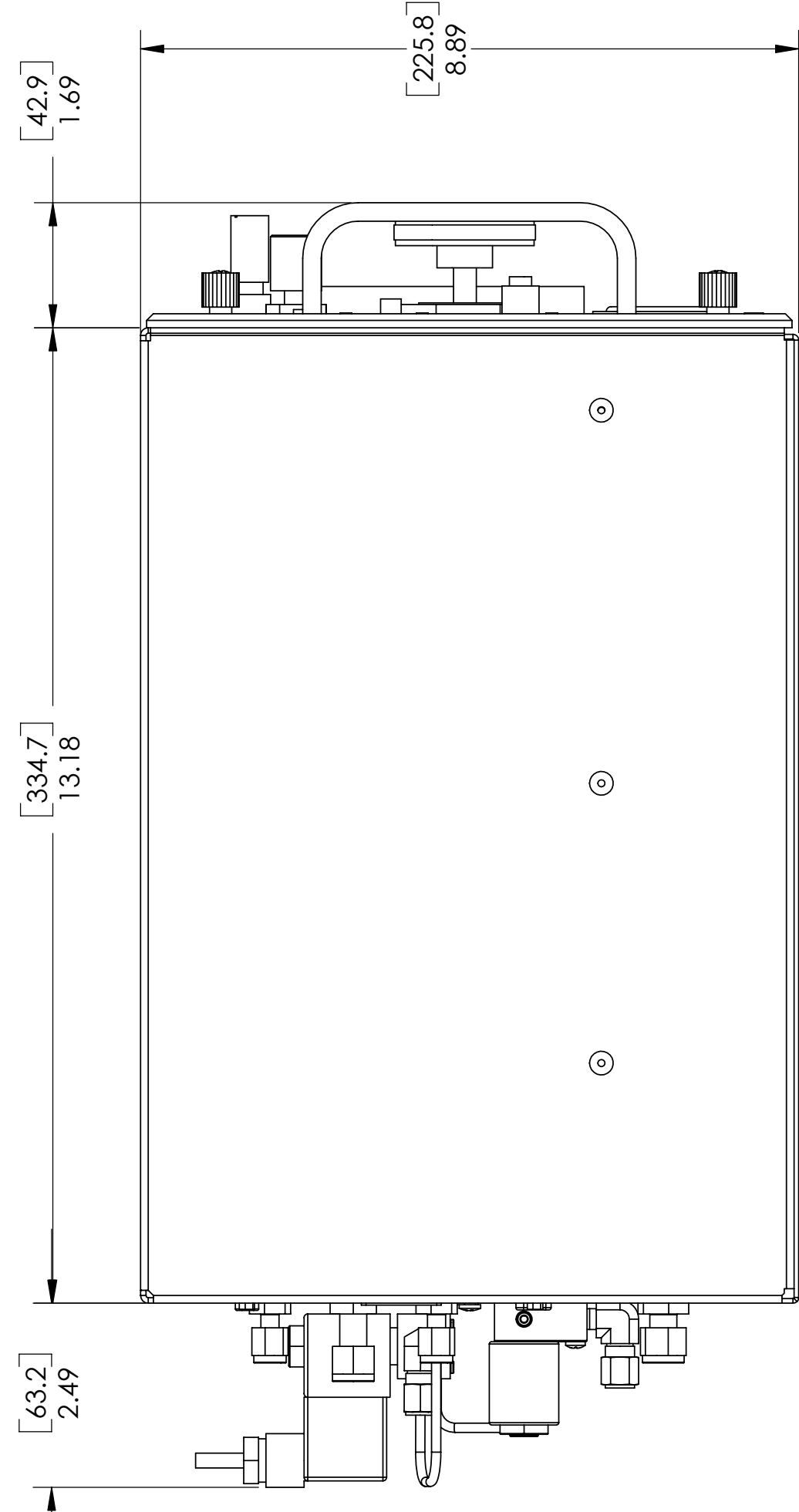

SIDE VIEW

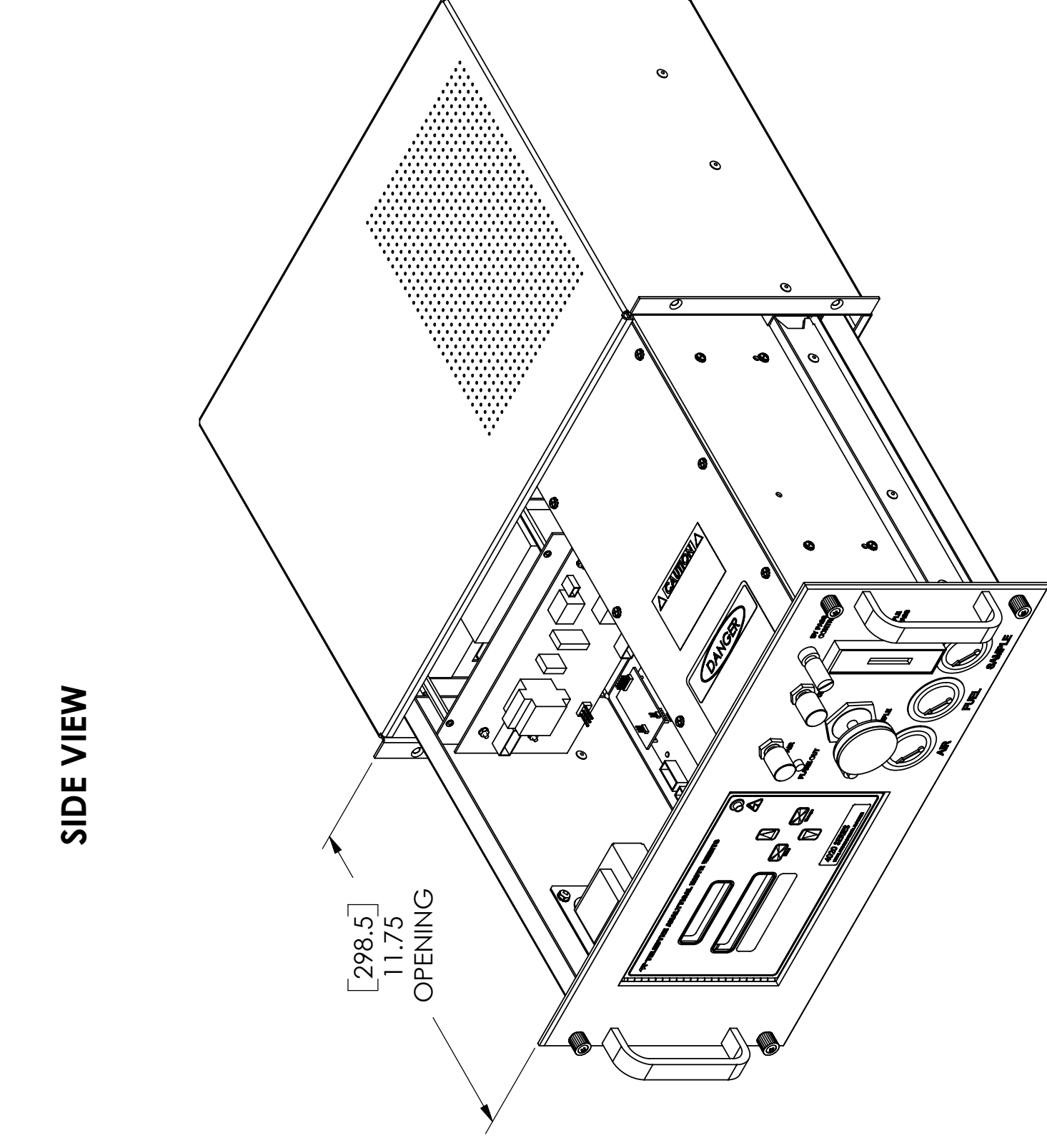

RECOMMENDED PANEL CUTOUT:
17.5 IN X 8.95 IN [445 MM X 227 MM]

REV	DESCRIPTION	DATE	APP.	REV.	BY
0	INITIAL RELEASE	1-22-03	MN		
1	UPDATES FOR CUSTOMER CONNECTIONS	3-14-03	QD	RE	
2	UPDATES PER REDLINE MARK-UPS	4-1-04	QD	AN	
3	ADDED DETAIL A FOR HYDROGEN BACKGROUND VIEW	4-8-04	QD	AN	
4	UPDATED ASSEMBLY MODEL ADDED NOTES 5 AND 6	10-31-05	LK	LK	
5	INC ECO 04-0050 ADDED MODEL ID LABEL B76673K	1-26-06	LK	LK	
6	INC ECO 07-0045	4/5/07	LL	LL	

REVISIONS

BILL OF MATERIALS		TITLE		SCALE
DO NOT SCALE DWG		DATE		NONE
TOLERANCE UNLESS OTHERWISE SPECIFIED: ANGULAR 1/12"		1/22/03		SIM
LINEAR { X = ± 0.1 XX = ± 0.02 XXX = ± 0.010		SIGNATURES		SHEET
		DRF: MANN NGUYEN		1 OF 1
		CHK:		
		APPR: QUYEN DANG		
		S.O.: Standard		
		CAD ID: D75508-6		
		REFERENCE		
		DWG NO. D-75508		REV 6

Teledyne Analytical Instruments
A business unit of Teledyne Electronic Technologies
CITY OF INDUSTRY, CALIFORNIA 91748

MODEL 4020
OUTLINE DIAGRAM

NOTES: UNLESS OTHERWISE SPECIFIED.

1. PREPARED LAW DOCUMENTS LISTED:
GRAPHIC SYMBOLS: ANSI Y32.2
REFERENCE DESIGNATORS: ANSI Y32.16
DEFINITIONS OF ENGR DWGS: ANSI Y14.15
2. FOR ASSEMBLY SEE C65507
3. RESISTANCE VALUES ARE IN OHMS, 1/BW, +/- 1%
4. CAPACITANCE VALUES ARE IN MICROFARADS, 50V, +/- 10%

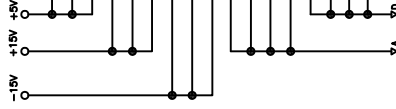
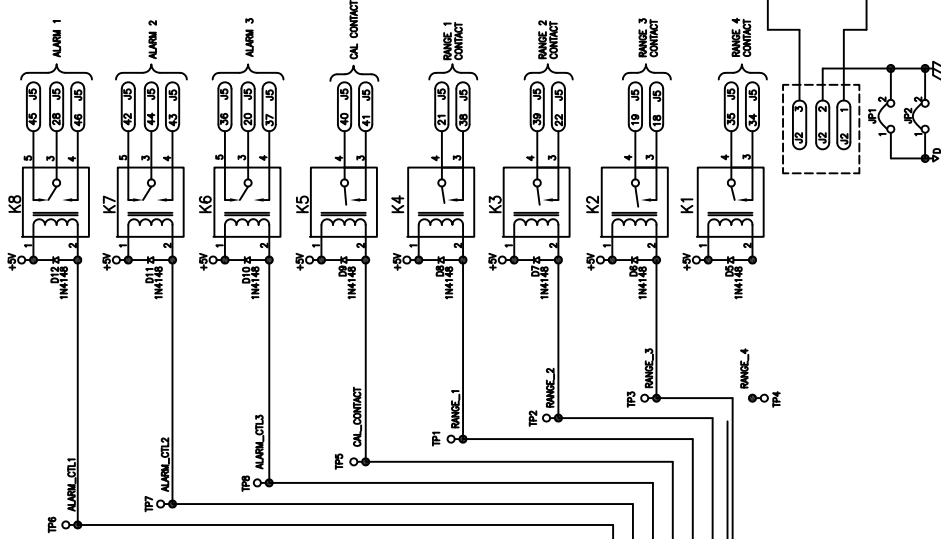
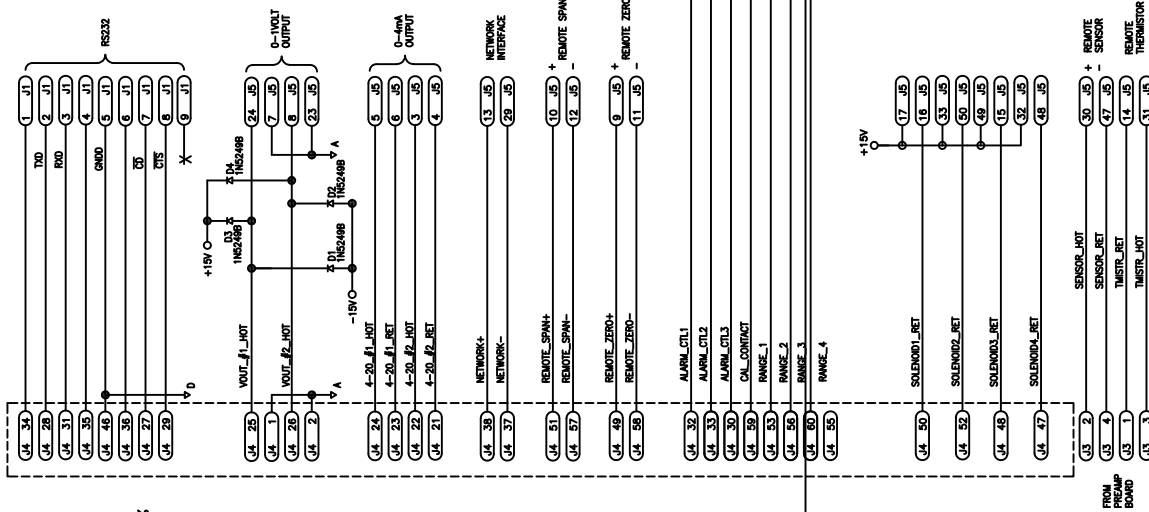

REV	DESCRIPTION	DATE	APP.
0	INITIAL RELEASE PER ECO 98-377	5/31/98	AA
1	INC. ECO 98-1149	1/14/98	AA
2	INC. ECO 97-0117	2/12/97	INC.
3	INC. ECO 97-0186	02/17/95	AA
4	INC. ECO 97-0186	02/17/95	AA
5	INC. ECO 10-2028	12/14/10	AA

ITEM	QTY	PART NO.	DESCRIPTION
BILL OF MATERIAL			
DO NOT SCALE DRAWING			
TELETYPE INSTRUMENTS			
ANALOGICAL INSTRUMENTS			
INDUSTRIAL I/P (MIL-STD-883C)			
MIL. REFERENCE CAD ID: D65506-3			
DATE: 5/13/98			
TITLE: SCHEMATIC DIAGRAM			
MODEL 3000 BACK PANEL			
BOARD (EURO VERSION)			
SCALE: NONE			
SHEET 1 OF 1			
REV: 5			

NOTES: UNLESS OTHERWISE SPECIFIED.
 1 IC (U2) CAN BE SUB WITH MAX420 OR MAX430CPA OR EQUIVALENT. ONLY INSTALL C8 AND C9 WHEN USING MAX420.
 2 CONDUCTOR SHOWN WITH DASHED LINES ARE MADE "OFF BOARD."

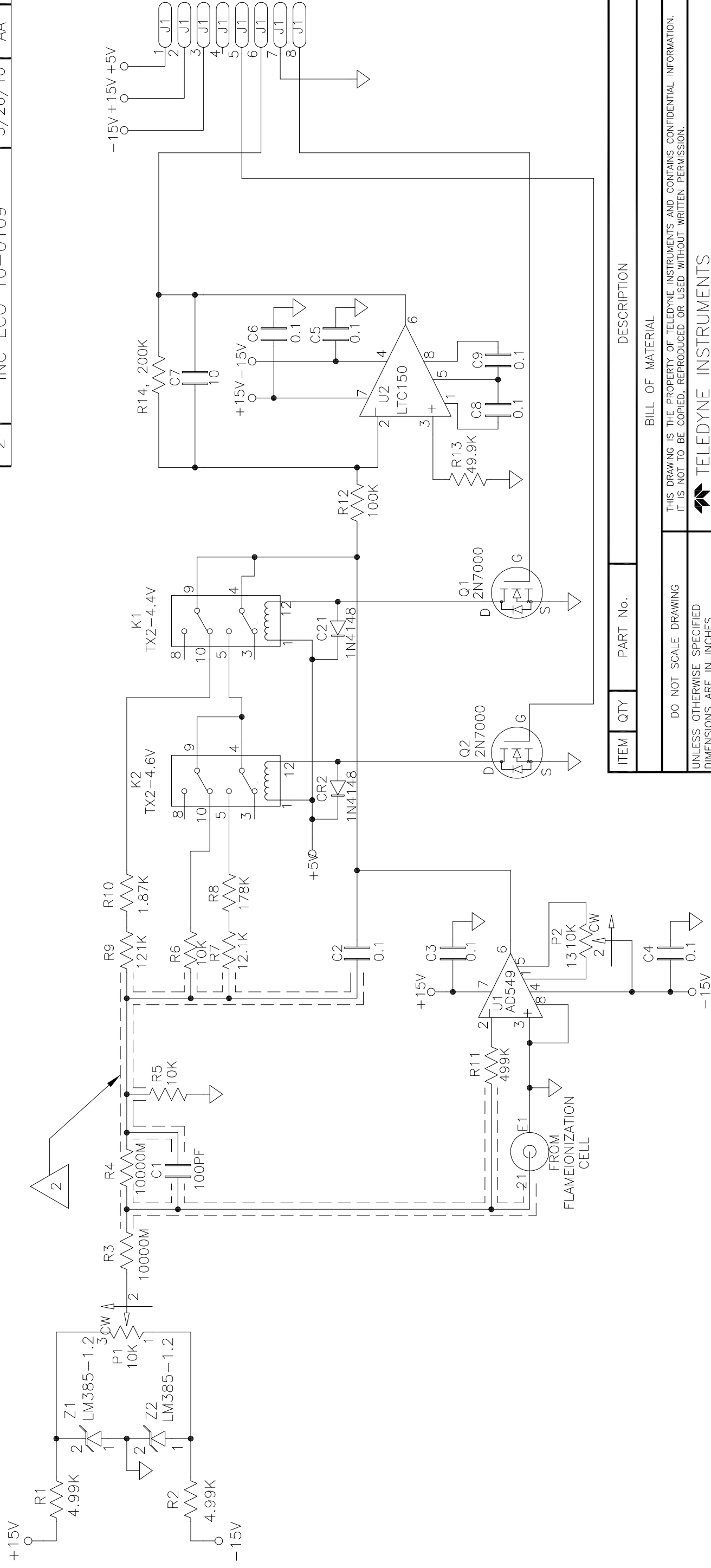

REVISIONS			
REV	DESCRIPTION	DATE	REV. BY
0	INC ECO 06-0132	5/10/07	RLM
1	INC ECO 09-0047	9/2/09	AA
2	INC ECO 10-0109	5/26/10	AA

ITEM	QTY	PART No.	DESCRIPTION
BILL OF MATERIAL			
DO NOT SCALE DRAWING			
UNLESS OTHERWISE SPECIFIED DIMENSIONS ARE IN INCHES			
TOLERANCE: (.X = ±.1 ,.XX = ±.02 ,.XXX = ±.010			
SIGNATURES		DATE	TITLE
DRFT: TM		5/10/07	SCHEMATIC DIAGRAM SIGNAL AMPLIFIER
CHK:			
APPR:			
ENGR: A.ALEGRIA			
C.O.:			
REFERENCE		CAD I.D. B79159-2	SCALE NONE
MATL.		N/A	SIM
DWG NO.		B-79159	SHEET 1 OF 1
REV		2	

THIS DRAWING IS THE PROPERTY OF TELEDYNE INSTRUMENTS AND CONTAINS CONFIDENTIAL INFORMATION. IT IS NOT TO BE COPIED, REPRODUCED OR USED WITHOUT WRITTEN PERMISSION.

TELEDYNE INSTRUMENTS
 Analytical Instruments
 A Teledyne Technologies Company
 City of Industry, California, 91748, USA

REVISIONS

REV.	DESCRIPTION	DATE	APP.	REV. BY
0	INC ECO 04-0050	1/25/06	QD	--
1	INC ECO 07-0010	5/2/06	LK	LK
2	INC ECO 18-0004	02/21/18	RF	VF
3	INC ECO 20-0070	11/13/20	AA	VF
4	INC ECO 22-0011	06/17/22	QD	VF

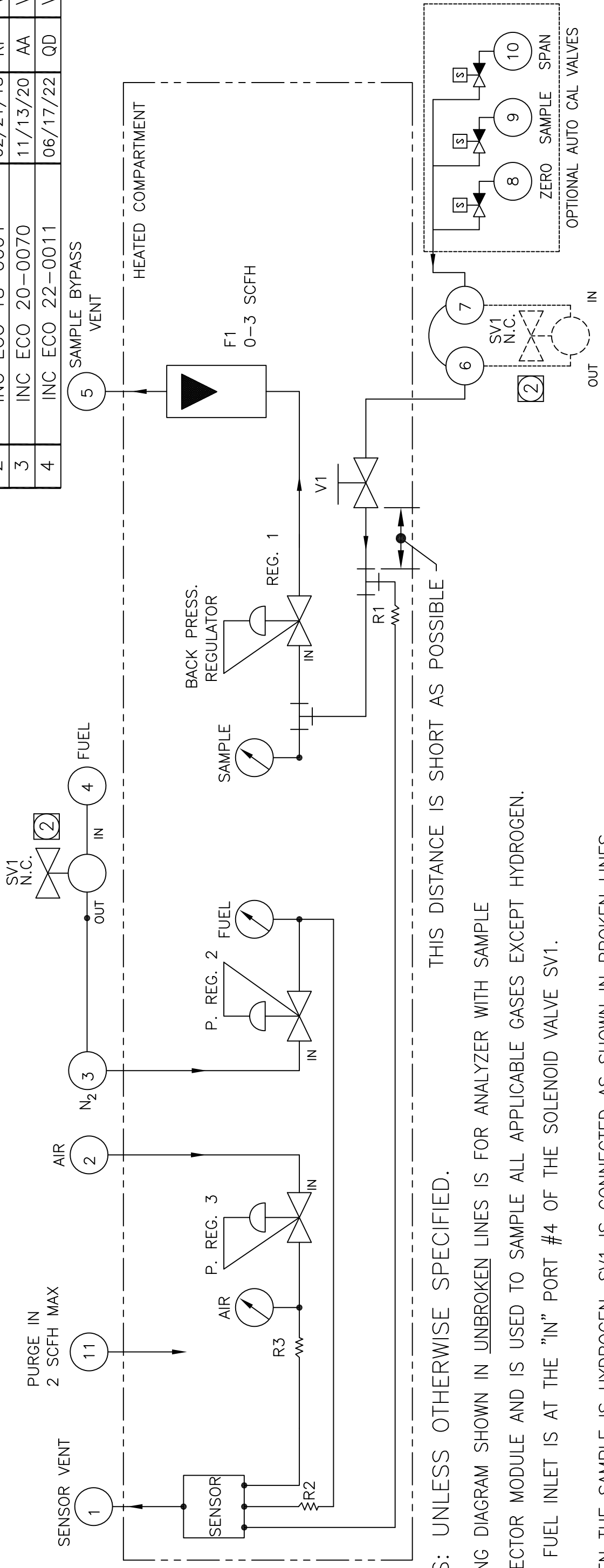

NOTES: UNLESS OTHERWISE SPECIFIED. THIS DISTANCE IS SHORT AS POSSIBLE

1. PIPING DIAGRAM SHOWN IN UNBROKEN LINES IS FOR ANALYZER WITH SAMPLE SELECTOR MODULE AND IS USED TO SAMPLE ALL APPLICABLE GASES EXCEPT HYDROGEN. THE FUEL INLET IS AT THE "IN" PORT #4 OF THE SOLENOID VALVE SV1.

2. WHEN THE SAMPLE IS HYDROGEN, SV1 IS CONNECTED AS SHOWN IN BROKEN LINES AND H.C. FREE NITROGEN IS CONNECTED TO INLET #3. NOTE THAT THE H₂ SAMPLE IS USED AS FUEL AND IS DILUTED WITH N₂ TO APPROXIMATE THE USUAL 40% H₂-60% N₂ MIXTURE.

3. MINIMUM-MAXIMUM INLET PRESSURE IS 10-40 PSIG (69-276 kPaG). PREFERRED INLET PRESSURE IS 15 PSIG (103 kPaG).

Use and Disclosure of Data
 "Information contained herein is classified as EAR99 under the U.S. Export Administration Regulation. Export, reexport or diversion contrary to U.S. law is prohibited."

ITEM	QTY	PART No.	DESCRIPTION
BILL OF MATERIAL			
DO NOT SCALE DRAWING			
UNLESS OTHERWISE SPECIFIED DIMENSIONS ARE IN INCHES			
TOLERANCE: ANGULAR ±1/2° LINEAR { X = ±.1 XX = ±.02 XXX = ±.010			
S/	SIGNATURES		DATE
N/	DRFT: MANN NGUYEN		1/21/03
I/	CHK:		
P/	APPR:		
O/	ENGR: QUYEN DANG		
F/	C.O.:		
REFERENCE	CAD I.D. B75509-4		
TITLE			SCALE NONE
MDL 4020 19" RACK			SIM B-67698
PIPING DIAGRAM			SHEET 1 OF 1
MATL. N/A			DWG NO. B-75509
			REV 4

THIS DRAWING IS THE PROPERTY OF TELEDYNE ANALYTICAL INSTRUMENTS AND CONTAINS CONFIDENTIAL INFORMATION. IT IS NOT TO BE COPIED, REPRODUCED OR USED WITHOUT WRITTEN PERMISSION.

TELEDYNE
 Analytical Instruments
 A Business Unit of Teledyne Instruments, Inc.
 City of Industry, California 91748, USA

NOTES: UNLESS OTHERWISE SPECIFIED.

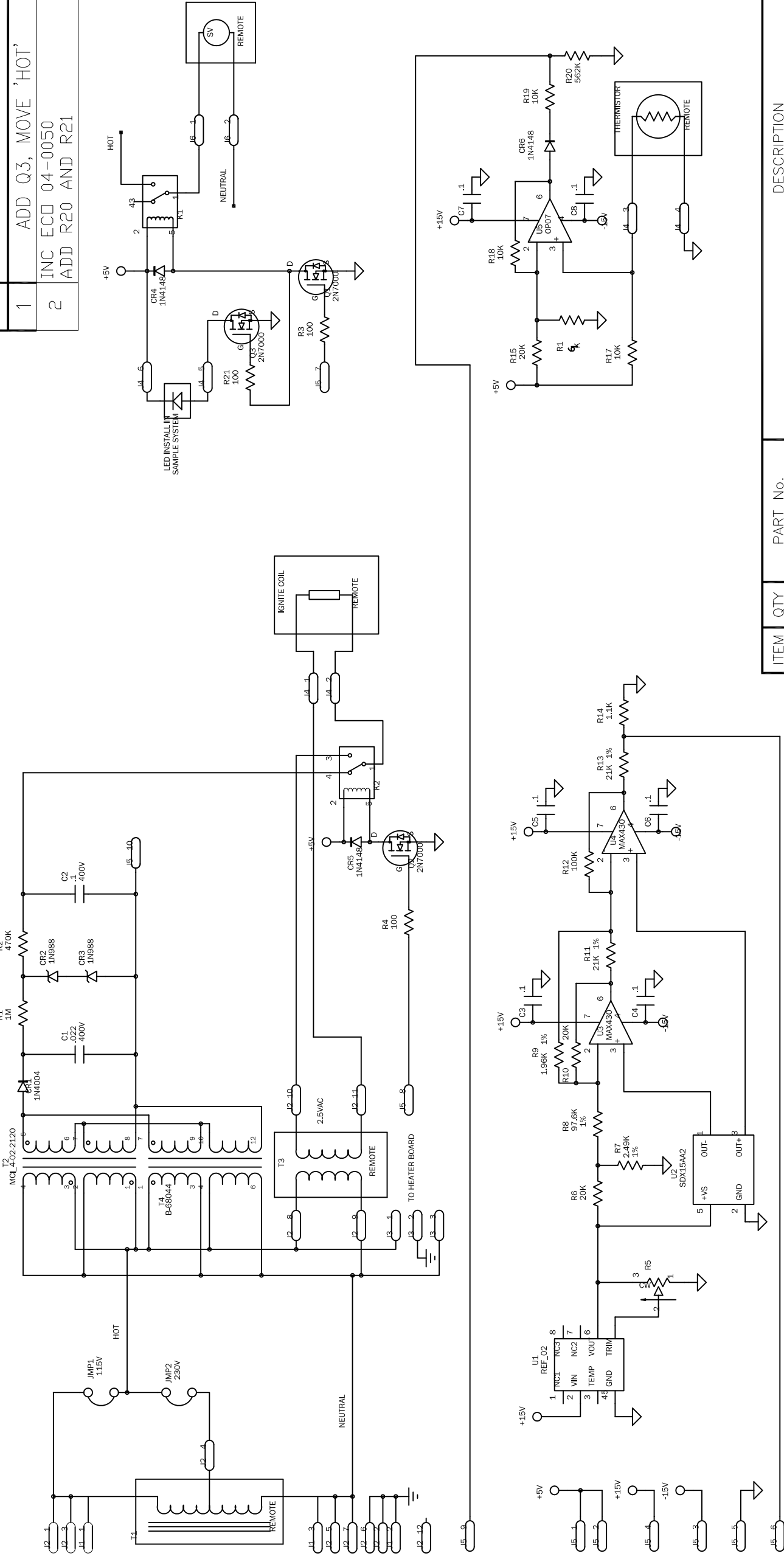

REVISIONS

REV.	DESCRIPTION	DATE	APP.	REV. BY.
1	ADD Q3, MOVE 'HOT'	4/12/04	QD	RLM
2	INC ECD 04-0050 ADD R20 AND R21	1/26/06	QD	RLM

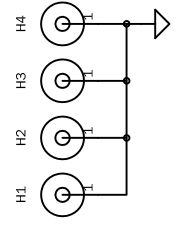
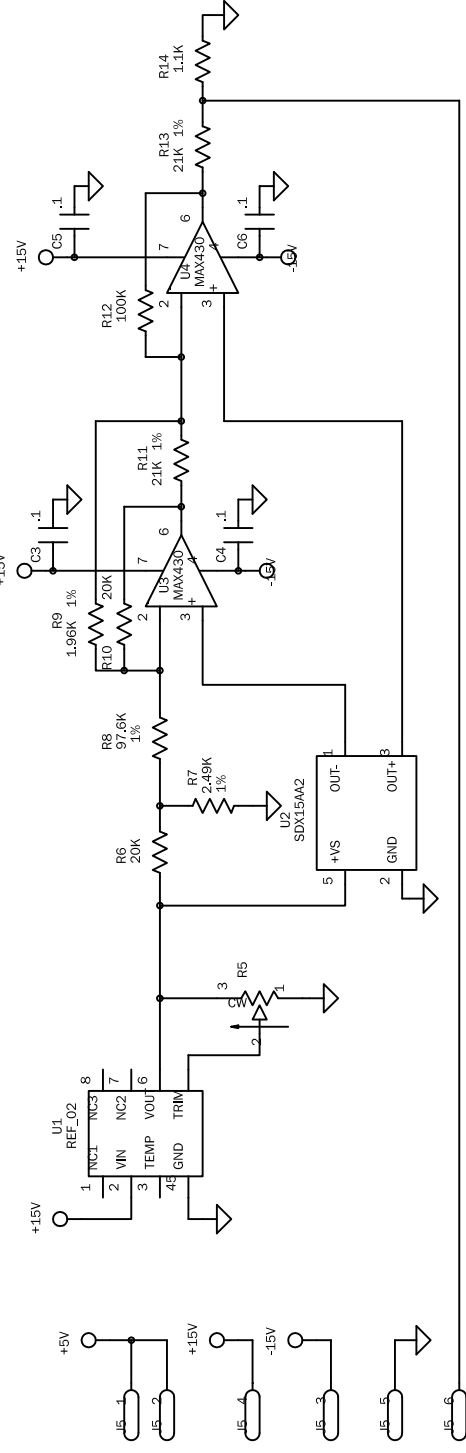
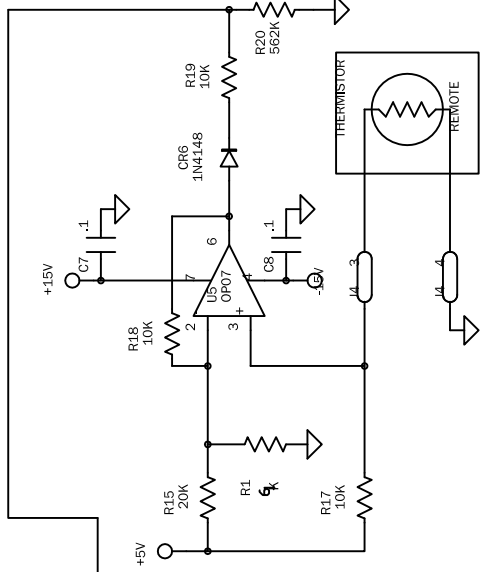
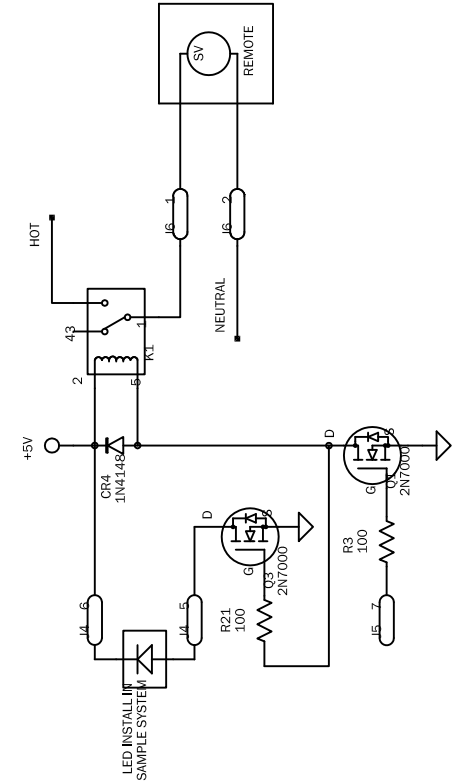

ITEM	QTY	PART No.	DESCRIPTION	
BILL OF MATERIAL				
DO NOT SCALE DWG				
TOLERANCE UNLESS OTHERWISE SPECIFIED: ANGULAR ±1/2°				
LINEAR { .X = ±.1 .XX = ±.02 .XXX = ±.010				
SIGNATURES		DATE	TITLE	
DRFT: R. MILVERSTED		7/15/03	SCHEMATIC DIAGRAM IGNITION/PSI COMP BOARD MODEL 4020	
CHK:				SCALE N/A
APPR:				SIM
ENGR: QUYEN DANG				SHEET 1 OF 1
C.O.:				REV
REFERENCE			DWG NO. B-74672	
			MATL. N/A	

THIS DRAWING IS THE PROPERTY OF TELEDYNE INSTRUMENTS AND CONTAINS CONFIDENTIAL INFORMATION. IT IS NOT TO BE COPIED, REPRODUCED OR USED WITHOUT WRITTEN PERMISSION.

TELEDYNE INSTRUMENTS
Analytical Instruments
A Teledyne Technologies Company
City of Industry, California, 91748, USA

- NOTES: UNLESS OTHERWISE SPECIFIED.
- FOR ITEMS CALLED OUT SEE FINAL ASSEMBLY DWG. D74661 FOR REF.
 - REF. FOR OLD SD TYPE PID CONNECTIONS SEE DETAIL "A"
 - THE FOLLOWING DENOTES WIRE SIZE:
*16AWG, BAL., 22AWG
 - SWAP BL AND BRN WIRES ON POWER ENTRY MODULE ASSEMBLY B64137.

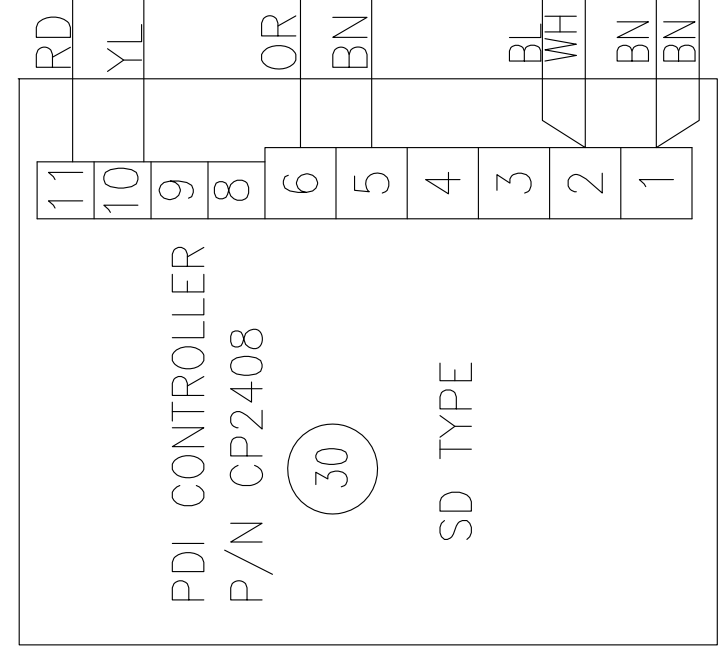
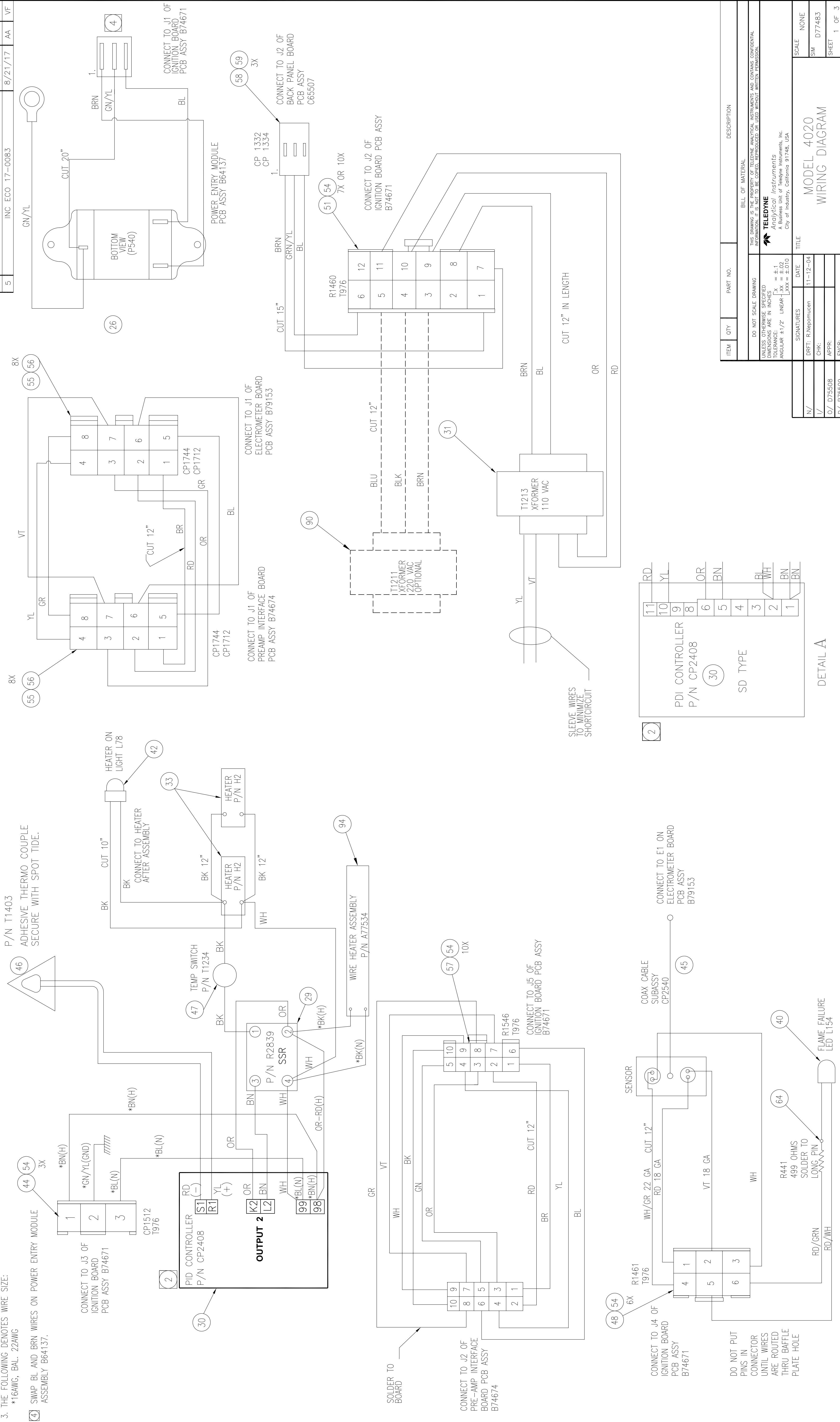

REV	DESCRIPTION	DATE	APP.	REV. BY
0	Initial Release	6/07/07	QD	--
1	PROD. REL. ECO 07-0171	10/24/07	LL	LL
2	PROD. REL. ECO 11-0072	07/22/11	QD	JA
3	INC. ECO 13-0025	3/15/13	AA	VF
4	INC. ECO 13-0055	7/17/13	AA	VF
5	INC. ECO 17-0083	8/21/17	AA	VF

ITEM	QTY	PART NO.	DESCRIPTION
BILL OF MATERIAL			
DO NOT SCALE DRAWING			
UNLESS OTHERWISE SPECIFIED DIMENSIONS ARE IN INCHES ANGULAR ±1/2° LINEAR ±.010			
THIS DRAWING IS THE PROPERTY OF TELEDYNE ANALYTICAL INSTRUMENTS AND CONTAINS CONFIDENTIAL INFORMATION. IT IS NOT TO BE COPIED, REPRODUCED OR USED WITHOUT WRITTEN PERMISSION.			
TELEDYNE Analytical Instruments A Business Unit of Teledyne Instruments, Inc. City of Industry, California 91748, USA			
SIGNATURES		DATE	TITLE
DRFT: R.Neumann		11-12-04	MODEL 4020 WIRING DIAGRAM
CHK:			
APPR:			
ENGR:			
C.O. STD			
CAD ID: D79161-4			
REFERENCE		SEE	D-79161
MATERIAL		FINAL	D74661
SCALE		NONE	
SHEET		1 OF 3	
REV.		5	

D C B A

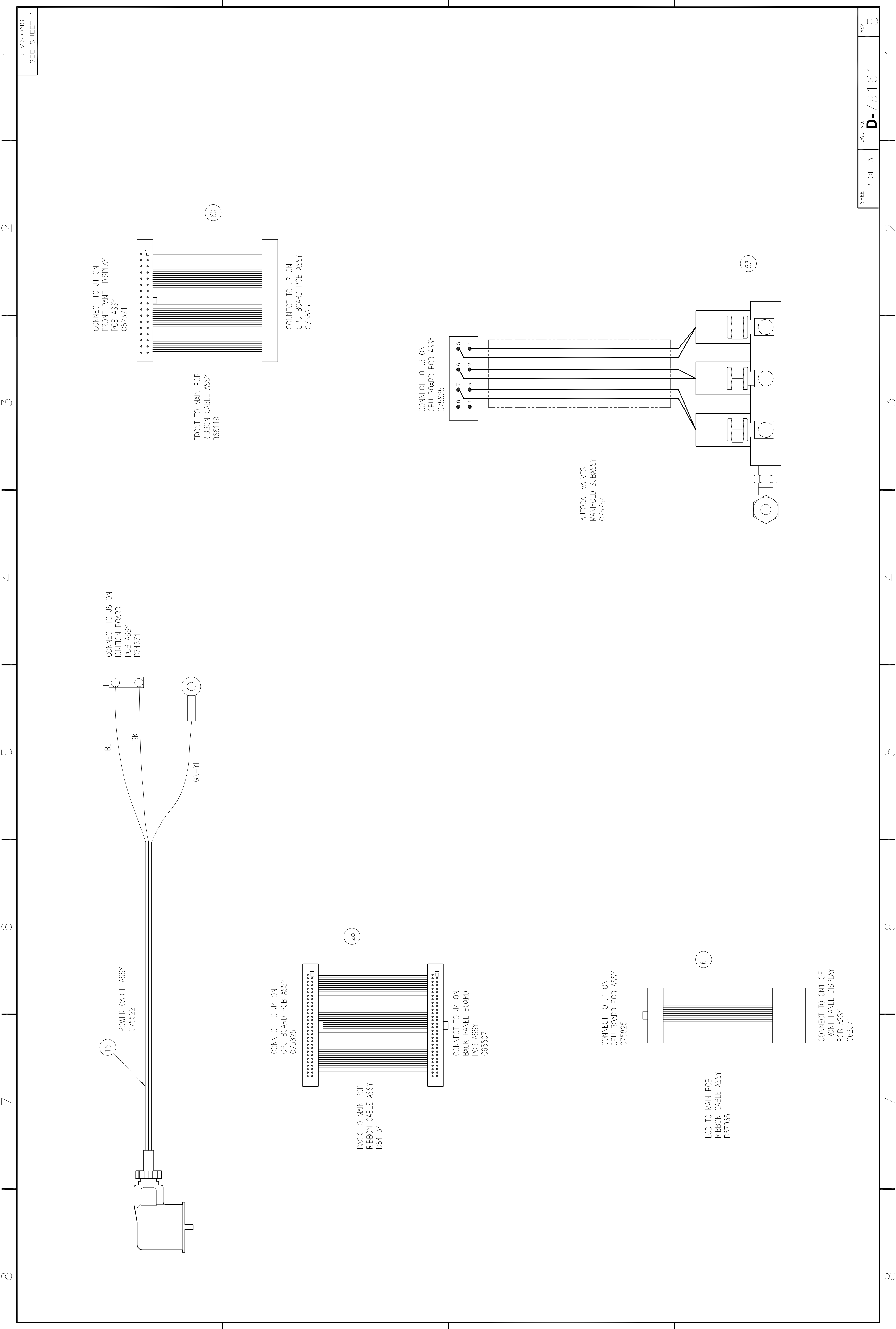

D C B A

REVISIONS
SEE SHEET 1

SHEET 2 OF 3
DWG. NO. **D-79161**
REV. 5

