

## Operation Manual for

Use and Disclosure of Data  
Information contained herein is classified as EAR99 under the  
U.S. Export Administration Regulations.  
Export, reexport or diversion contrary to U.S. law is prohibited.

# *Model 6200T* *UV Fluorescence Total Sulfur Analyzer*



P/N M6200T  
DATE  
11/06/2020

### *Teledyne Analytical Instruments*

16830 Chestnut Street  
City of Industry, CA 91748  
Telephone: (626) 934-1500  
Fax: (626) 961-2538

Web: [www.teledyne-ai.com](http://www.teledyne-ai.com)



### Copyright © 2017 Teledyne Analytical Instruments

All Rights Reserved. No part of this manual may be reproduced, transmitted, transcribed, stored in a retrieval system, or translated into any other language or computer language in whole or in part, in any form or by any means, whether it be electronic, mechanical, magnetic, optical, manual, or otherwise, without the prior written consent of Teledyne Analytical Instruments, 16830 Chestnut Street, City of Industry, CA 91748.

### Warranty

This equipment is sold subject to the mutual agreement that it is warranted by us free from defects of material and of construction, and that our liability shall be limited to replacing or repairing at our factory (without charge, except for transportation), or at customer plant at our option, any material or construction in which defects become apparent within one year from the date of shipment, except in cases where quotations or acknowledgements provide for a shorter period. Components manufactured by others bear the warranty of their manufacturer. This warranty does not cover defects caused by wear, accident, misuse, neglect or repairs other than those performed by Teledyne or an authorized service center. We assume no liability for direct or indirect damages of any kind and the purchaser by the acceptance of the equipment will assume all liability for any damage which may result from its use or misuse.

We reserve the right to employ any suitable material in the manufacture of our apparatus, and to make any alterations in the dimensions, shape or weight of any parts, in so far as such alterations do not adversely affect our warranty.

### Important Notice

This instrument provides measurement readings to its user, and serves as a tool by which valuable data can be gathered. The information provided by the instrument may assist the user in eliminating potential hazards caused by his process; however, it is essential that all personnel involved in the use of the instrument or its interface be properly trained in the process being measured, as well as all instrumentation related to it.

The safety of personnel is ultimately the responsibility of those who control process conditions. While this instrument may be able to provide early warning of imminent danger, it has no control over process conditions, and it can be misused. In particular, any alarm or control systems installed must be tested and understood, both as to how they operate and as to how they can be defeated. Any safeguards required such as locks, labels, or redundancy, must be provided by the user or specifically requested of Teledyne at the time the order is placed.

Therefore, the purchaser must be aware of the hazardous process conditions. The purchaser is responsible for the training of personnel, for providing hazard warning methods and instrumentation per the appropriate standards, and for ensuring that hazard warning devices and instrumentation are maintained and operated properly.

Teledyne Analytical Instruments, the manufacturer of this instrument, cannot accept responsibility for conditions beyond its knowledge and control. No statement expressed or implied by this document or any information disseminated by the manufacturer or its agents, is to be construed as a warranty of adequate safety control under the user's process conditions.

### Trademarks

All trademarks, registered trademarks, brand names or product names appearing in this document are the property of their respective owners and are used herein for identification purposes only.

### **ABOUT THIS MANUAL**

This manual describes operation, specifications, and maintenance for the Model 6200T.

In addition this manual contains important SAFETY messages for this instrument. It is strongly recommended that you read that operation manual in its entirety before operating the instrument.

**This page intentionally left blank.**

## SAFETY MESSAGES

Important safety messages are provided throughout this manual for the purpose of avoiding personal injury or instrument damage. Please read these messages carefully. Each safety message is associated with a safety alert symbol, and are placed throughout this manual; the safety symbols are also located inside the instrument. **It is imperative that you pay close attention to these messages, the descriptions of which are as follows:**



**WARNING:** Electrical Shock Hazard



**HAZARD:** Strong oxidizer



**GENERAL WARNING/CAUTION:** Read the accompanying message for specific information.



**CAUTION:** Hot Surface Warning



**Do Not Touch:** Touching some parts of the instrument without protection or proper tools could result in damage to the part(s) and/or the instrument.



**Technician Symbol:** All operations marked with this symbol are to be performed by qualified maintenance personnel only.



**Electrical Ground:** This symbol inside the instrument marks the central safety grounding point for the instrument.

### CAUTION



This instrument should only be used for the purpose and in the manner described in this manual. If you use this instrument in a manner other than that for which it was intended, unpredictable behavior could ensue with possible hazardous consequences.

**NEVER** use any gas analyzer to sample combustible gas(es)!

**Note:** Technical Assistance regarding the use and maintenance of the 6200T or any other Teledyne product can be obtained by contacting Teledyne Customer Service Department:

Phone: 888-789-8168

Email: [ask\\_tai@teledyne.com](mailto:ask_tai@teledyne.com)

or by accessing various service options on our website at <http://www.teledyne-ai.com/>

## CONSIGNES DE SÉCURITÉ

Des consignes de sécurité importantes sont fournies tout au long du présent manuel dans le but d'éviter des blessures corporelles ou d'endommager les instruments. Veuillez lire attentivement ces consignes. Chaque consigne de sécurité est représentée par un pictogramme d'alerte de sécurité; ces pictogrammes se retrouvent dans ce manuel et à l'intérieur des instruments. Les symboles correspondent aux consignes suivantes :



**AVERTISSEMENT** : Risque de choc électrique



**DANGER** : Oxydant puissant



**AVERTISSEMENT GÉNÉRAL / MISE EN GARDE** : Lire la consigne complémentaire pour des renseignements spécifiques



**MISE EN GARDE** : Surface chaude



**Ne pas toucher** : Toucher à certaines parties de l'instrument sans protection ou sans les outils appropriés pourrait entraîner des dommages aux pièces ou à l'instrument.



**Pictogramme « technicien »** : Toutes les opérations portant ce symbole doivent être effectuées uniquement par du personnel de maintenance qualifié.



**Mise à la terre** : Ce symbole à l'intérieur de l'instrument détermine le point central de la mise à la terre sécuritaire de l'instrument.

### MISE EN GARDE



**Cet instrument doit être utilisé aux fins décrites et de la manière décrite dans ce manuel. Si vous utilisez cet instrument d'une autre manière que celle pour laquelle il a été prévu, l'instrument pourrait se comporter de façon imprévisible et entraîner des conséquences dangereuses.**

**NE JAMAIS utiliser un analyseur de gaz pour échantillonner des gaz combustibles!**

## TABLE OF CONTENTS

<b>SAFETY MESSAGES</b> .....	<b>V</b>
<b>CONSIGNES DE SÉCURITÉ</b> .....	<b>VI</b>
<b>TABLE OF CONTENTS</b> .....	<b>VII</b>
List of Figures .....	vii
List of Tables .....	xiii
<b>PART I GENERAL INFORMATION</b> .....	<b>1</b>
<b>1. INTRODUCTION, FEATURES AND OPTIONS</b> .....	<b>3</b>
1.1. 6200T Overview .....	3
1.2. Features .....	4
1.3. Configurations .....	4
1.4. The M501TS – Total Reduced Sulfur Converter .....	8
<b>2. SPECIFICATIONS, APPROVALS &amp; COMPLIANCE</b> .....	<b>10</b>
2.1. Specifications and Approvals .....	10
2.2. EPA Equivalency Designation .....	11
2.3. CE Mark Compliance .....	12
2.3.1. Emissions Compliance .....	12
2.3.2. Safety Compliance .....	12
<b>3. GETTING STARTED</b> .....	<b>14</b>
3.1. Unpacking the 6200T Analyzer .....	14
3.1.1. Ventilation Clearance .....	15
3.2. Instrument Layout .....	15
3.2.1. Front Panel .....	15
3.2.2. Rear Panel .....	19
3.2.3. Internal Chassis Layout .....	21
3.3. Connections and Setup .....	23
3.3.1. Electrical Connections .....	23
3.3.2. Pneumatic Connections .....	33
3.4. Startup, Functional Checks, and Initial Calibration .....	40
3.4.1. Startup .....	40
3.4.2. Warning Messages .....	40
3.4.3. Functional Checks .....	43
3.4.4. Initial Calibration .....	44
<b>PART II OPERATING INSTRUCTIONS</b> .....	<b>51</b>
<b>4. OVERVIEW OF OPERATING MODES</b> .....	<b>53</b>
4.1. Sample Mode .....	56
4.1.1. Test Functions .....	56
4.1.2. Warning Messages .....	58
4.2. Calibration Mode .....	60
4.3. Setup Mode .....	60
4.3.1. Password Security .....	60
4.3.2. Primary Setup Menu .....	61
4.3.3. Secondary Setup Menu (SETUP>MORE) .....	61
<b>5. SETUP MENU</b> .....	<b>62</b>
5.1. SETUP – CFG: Configuration Information .....	62
5.2. SETUP – ACAL: Automatic Calibration Option .....	62
5.3. SETUP – DAS: Internal Data Acquisition System .....	62
5.4. SETUP – RNGE: Range Configuration .....	63
5.4.1. Range Units .....	63
5.4.2. Dilution Ratio (Option) .....	64



<b>5.5. SETUP – PASS: Password Protection</b> .....	<b>67</b>
<b>5.6. SETUP – CLK: Setting the Internal Time-of-Day Clock</b> .....	<b>69</b>
5.6.1. Time of Day .....	69
5.6.2. Date .....	70
5.6.3. Clock Adjust.....	70
<b>5.7. SETUP – COMM: Communications Ports</b> .....	<b>71</b>
5.7.1. ID (Instrument Identification) .....	72
5.7.2. INET (Ethernet).....	72
5.7.3. COM1 and COM2 (Mode, Baud Rate and Test Port).....	72
<b>5.8. SETUP – VARS: Variables Setup and Definition</b> .....	<b>70</b>
<b>5.9. SETUP – DIAG: Diagnostics Functions</b> .....	<b>71</b>
5.9.1. Signal I/O .....	72
5.9.2. Analog Output Step Test .....	73
5.9.3. Analog I/O Configuration .....	77
5.9.4. Optic Test .....	78
5.9.5. Electrical Test .....	79
5.9.6. Lamp Calibration .....	80
5.9.7. Pressure Calibration .....	81
5.9.8. Flow Calibration .....	82
5.9.9. Display Sequence Config .....	82
<b>6. COMMUNICATIONS SETUP AND OPERATION</b> .....	<b>81</b>
<b>6.1. Data Terminal / Communication Equipment (DTE DCE)</b> .....	<b>81</b>
<b>6.2. Communication Modes, Baud Rate and Port testing</b> .....	<b>81</b>
6.2.1. Communication Modes.....	<b>Error! Bookmark not defined.</b>
6.2.2. COMM Port Baud Rate.....	87
6.2.3. COMM Port Testing.....	88
<b>6.3. RS-232</b> .....	<b>88</b>
<b>6.4. Ethernet</b> .....	<b>89</b>
6.4.1. Configuring Ethernet Communication Manually (Static IP Address).....	89
6.4.2. Configuring Ethernet Communication Using Dynamic Host Configuration Protocol (DHCP) .....	92
6.4.3. USB Port .....	91
<b>7. DATA ACQUISITION SYSTEM (DAS) AND APICOM</b> .....	<b>97</b>
<b>8. REMOTE OPERATION OF THE ANALYZER</b> .....	<b>99</b>
<b>8.1. Remote Operation Using the External Digital I/O</b> .....	<b>99</b>
8.1.1. Status Outputs.....	99
8.1.2. Control Inputs.....	100
<b>8.2. Remote Operation Using the External Serial I/O</b> .....	<b>101</b>
8.2.1. Terminal Operating Modes .....	101
8.2.2. Help Commands in Terminal Mode.....	102
8.2.3. Command Syntax .....	102
8.2.4. Data Types.....	103
8.2.5. Status Reporting.....	103
<b>8.3. Remote Access by Modem</b> .....	<b>100</b>
<b>8.4. COM Port Password Security</b> .....	<b>106</b>
<b>8.5. Additional Communications Documentation</b> .....	<b>107</b>
<b>8.6. Additional Calibration Details</b> .....	<b>Error! Bookmark not defined.</b>
8.6.1. Calibration with Remote Contact Closures .....	<b>Error! Bookmark not defined.</b>
<b>8.7. Automatic Calibration (AutoCal)</b> .....	<b>108</b>
8.7.1. Switching TAI Protocol ON/OFF .....	108
8.12.2. AutoCal Modes.....	109
<b>8.13. Calibration Quality</b> .....	<b>112</b>
<b>PART III MAINTENANCE AND SERVICE</b> .....	<b>113</b>
<b>9. INSTRUMENT MAINTENANCE</b> .....	<b>115</b>
<b>9.1. Maintenance Schedule</b> .....	<b>116</b>

<b>9.2. Predictive Diagnostics</b> .....	<b>117</b>
<b>9.3. Maintenance Procedures</b> .....	<b>118</b>
9.3.1. Changing the Sample Particulate Filter .....	118
9.3.2. Changing the IZS Permeation Tube .....	119
9.3.3. Changing theTS and Zero Air Scrubber Materials .....	119
9.3.4. Changing the Critical Flow Orifice .....	120
9.3.5. Checking for Light Leaks .....	121
9.3.6. Detailed Pressure Leak Check .....	122
9.3.7. Performing a Sample Flow Check.....	123
9.3.8. Hydrocarbon Scrubber ( <i>Kicker</i> ) .....	123
<b>10. TROUBLESHOOTING &amp; SERVICE</b> .....	<b>125</b>
<b>10.1. General Troubleshooting</b> .....	<b>125</b>
10.1.1. Fault Diagnostics with Warning Messages .....	127
10.1.2. Fault Diagnosis with Test Functions .....	129
10.1.3. Using the Diagnostic Signal I/O Functions.....	131
<b>10.2. Gas Flow Problems</b> .....	<b>133</b>
10.2.1. Zero or Low Sample Flow .....	133
10.2.2. High Flow.....	133
<b>10.3. Calibration Problems</b> .....	<b>133</b>
10.3.1. Negative Concentrations.....	133
10.3.2. No Response.....	134
10.3.3. Unstable Zero and Span .....	134
10.3.4. Inability to Span - No SPAN Button .....	135
10.3.5. Inability to Zero - No ZERO Button .....	135
10.3.6. Non-Linear Response .....	135
10.3.7. Discrepancy Between Analog Output and Display.....	136
<b>10.4. Other Performance Problems</b> .....	<b>136</b>
10.4.1. Excessive noise .....	136
10.4.2. Slow Response.....	136
10.4.3. The Analyzer Doesn't Appear on the LAN or Internet.....	137
<b>10.5. Subsystem Checkout</b> .....	<b>137</b>
10.5.1. AC Power Configuration .....	137
10.5.2. DC Power Supply .....	138
10.5.3. I <sup>2</sup> C Bus .....	139
10.5.4. Touch-screen Interface .....	139
10.5.5. LCD Display Module .....	139
10.5.6. Relay Board .....	140
10.5.7. Motherboard.....	140
10.5.8. CPU .....	142
10.5.9. RS-232 Communication .....	142
10.5.10. Shutter System .....	143
10.5.11. PMT Sensor .....	144
10.5.12. PMT Preamplifier Board.....	144
10.5.13. PMT Temperature Control PCA.....	144
10.5.14. High Voltage Power Supply .....	144
10.5.15. Pneumatic Sensor Assembly .....	145
10.5.16. Sample Pressure.....	146
10.5.17. IZS Option.....	146
10.5.18. Box Temperature .....	146
10.5.19. PMT Temperature .....	147
<b>10.6. Service Procedures</b> .....	<b>148</b>
10.6.1. Sensor Module Repair & Cleaning.....	148
<b>10.7. M501TS Converter Maintenance</b> .....	<b>165</b>
10.7.1. Changing the Quartz Tube.....	165
10.7.2. Checking the Converter Efficiency .....	166

10.7.3. Sample Diluter Maintenance.....	168
10.7.4. Thermocouple Replacement.....	169
<b>10.8. Frequently Asked Questions (FAQs) .....</b>	<b>171</b>
<b>10.9. Technical Assistance .....</b>	<b>172</b>
<b>11. PRINCIPLES OF OPERATION .....</b>	<b>173</b>
<b>11.1. Sulfur Dioxide (SO<sub>2</sub>) Sensor Principles of operation .....</b>	<b>173</b>
11.1.1. SO <sub>2</sub> Ultraviolet Fluorescence Measurement Principle .....	173
11.1.2. The UV Light Path.....	176
11.1.3. UV Source Lamp .....	176
11.1.4. The Reference Detector .....	177
11.1.5. The PMT .....	177
11.1.6. UV Lamp Shutter & PMT Offset .....	177
11.1.7. Optical Filters .....	178
11.1.8. Optical Lenses .....	180
11.1.9. Measurement Interferences .....	181
<b>11.2. Pneumatic Operation.....</b>	<b>182</b>
11.2.1. Sample Gas Flow .....	182
11.2.2. Flow Rate Control.....	184
11.2.3. Hydrocarbon Scrubber (Kicker) .....	185
11.2.4. Pneumatic Sensors .....	186
<b>11.3. Electronic Operation.....</b>	<b>187</b>
11.3.1. CPU .....	189
11.3.2. Sensor Module .....	190
11.3.3. Photo Multiplier Tube (PMT) .....	192
11.3.4. PMT Cooling System.....	190
11.3.5. PMT Preamplifier .....	191
11.3.6. Pneumatic Sensor Board .....	193
11.3.7. Relay Board .....	193
11.3.8. Motherboard.....	195
11.3.9. Analog Outputs .....	196
11.3.10. External Digital I/O .....	196
11.3.11. I <sup>2</sup> C Data Bus.....	196
11.3.12. Power up Circuit.....	196
11.3.13. Power Supply/ Circuit Breaker .....	196
<b>11.4. Front Panel/Display Interface .....</b>	<b>198</b>
11.4.1. LVDS Transmitter Board .....	199
11.4.2. Front Panel Interface PCA .....	199
11.4.3. TS1, Display Calibration Procedure .....	200
11.4.4. How to Troubleshoot 6200T Display Touchscreen Issues .....	201
<b>11.5. Software Operation .....</b>	<b>207</b>
11.5.1. Adaptive Filter .....	207
11.5.2. Calibration - Slope and Offset .....	208
11.5.3. Temperature and Pressure Compensation (TPC) Feature .....	209
11.5.4. Internal Data Acquisition System (DAS) .....	209
<b>12. GLOSSARY .....</b>	<b>211</b>
<b>13. SPARE PARTS .....</b>	<b>215</b>
13.1. Spare Parts and Annual Maintenance Kit .....	215

**LIST OF FIGURES**

Figure 1-1:	6200T Basic Design.....	3
Figure 1-2:	6200T Basic Configuration .....	5
Figure 1-3:	6200T with IZS/Permeation Tube Option .....	6
Figure 1-4:	6200T with PRC6000, Precision Calibrator.....	7
Figure 1-5:	M501TS, Component Layout, 110VAC Configuration .....	9
Figure 1-6:	M501TS, Component Layout, 220VAC Configuration .....	9
Figure 3-1:	Front Panel Layout .....	16
Figure 3-2:	Display Screen and Touch Control .....	16
Figure 3-3:	Display/Touch Control Screen Mapped to Menu Charts .....	18
Figure 3-4:	Rear Panel Layout—Converter and Analyzer.....	19
Figure 3-5:	6200T, Internal Layout.....	21
Figure 3-6:	501TS, Converter Layout.....	21
Figure 3-7:	Analog In Connector.....	24
Figure 3-8:	Analog Output Connector .....	25
Figure 3-9:	Current Loop Option Installed on Mother Board.....	27
Figure 3-10:	Status Output Connector .....	27
Figure 3-11:	Control Input Connector .....	29
Figure 3-12:	Concentration Alarm Relay .....	30
Figure 3-13:	Rear Panel Connector Pin-Outs for RS-232 Mode.....	31
Figure 3-14:	CPU Connector Pin-Outs for RS-232 Mode .....	32
Figure 3-15:	Pneumatic Layout.....	35
Figure 3-16:	Pneumatic Layout with H <sub>2</sub> S Permeation Device Options.....	37
Figure 3-17:	Warning Messages .....	41
Figure 3-18:	Functional Check.....	43
Figure 3-19:	TS Span Gas Concentration Settings .....	43
Figure 3-20:	6200T, Stanadard Pneumatic SetUp for Calibration & Sampling.....	43
Figure 3-21:	6200T with PRC6000/702, Pneumatic SetUp for Calibration & Sampling.....	43
Figure 3-22:	6200T, Zero Calibration Procedure .....	43
Figure 3-23:	6200T, Span Calibration Procedure.....	43
Figure 4-1:	Front Panel Display .....	53
Figure 4-2:	Viewing and Clearing 6200T WARNING Messages.....	59
Figure 5-1:	SETUP RNGE – Dilution Ratio .....	66
Figure 5-2:	SETUP – Enable Password Security .....	67
Figure 6-1:	COMM – COMM Port Baud Rate.....	87
Figure 6-2:	COMM – COM1 Test Port.....	88
Figure 6-3:	COMM – LAN / Internet Manual Configuration .....	91
Figure 6-4:	COMM – LAN / Internet Automatic Configuration.....	92
Figure 6-5:	COMM – Change Hostname.....	90
Figure 8-1:	Status Output Connector .....	99
Figure 8-2:	Control Inputs with Local 5 V Power Supply .....	101
Figure 8-3:	Control Inputs with External 5 V Power Supply .....	101
Figure 8-4:	AUTO CAL – User Defined Sequence.....	111
Figure 9-1:	Sample Particulate Filter Assembly.....	118
Figure 9-2:	Critical Flow Orifice Assembly .....	120
Figure 9-3:	Simple Leak Check Fixture.....	123
Figure 9-4:	Hydrocarbon Scrubber Leak Check Setup .....	124
Figure 10-1:	Viewing and Clearing Warning Messages .....	127
Figure 10-2:	Example of Signal I/O Function .....	132
Figure 10-3:	Location of Relay Board Power Configuration Jumper .....	138
Figure 10-4:	Manual Activation of the UV Light Shutter .....	144
Figure 10-5:	Sensor Module Wiring and Pneumatic Fittings.....	148
Figure 10-6:	Sensor Module Mounting Screws .....	150
Figure 10-7:	Sample Chamber Mounting Bracket .....	151

Figure 10-8:	Hex Screw Between Lens Housing and Sample Chamber .....	152
Figure 10-9:	UV Lens Housing / Filter Housing .....	152
Figure 10-10:	PMT UV Filter Housing Disassembled .....	153
Figure 10-11:	Disassembling the Shutter Assembly .....	155
Figure 10-12:	Shutter Assembly .....	156
Figure 10-13:	UV Lamp Adjustment .....	157
Figure 10-14:	Location of UV Reference Detector Potentiometer .....	158
Figure 10-15:	PMT Assembly - Exploded View .....	160
Figure 10-16:	Pre-Amplifier Board (Preamp PCA) Layout.....	162
Figure 10-17:	501TS, Quartz Tube Replacement Procedure .....	162
Figure 10-18:	501TS, Internal Layout of Converter(220VAC Version).....	162
Figure 10-19:	Dilutor Flow Block Assembly .....	162
Figure 10-20:	501TS, Thermocouple & Temperature Controller Location.....	162
Figure 10-21:	501TS, Quartz Tube Cavity for Thermocouple .....	162
Figure 10-20:	501TS, Thermocouple Installation Procedure.....	162
Figure 11-1:	UV Absorption .....	174
Figure 11-2:	UV Light Path.....	176
Figure 11-3:	Source UV Lamp Construction .....	177
Figure 11-4:	Excitation Lamp UV Spectrum Before/After Filtration.....	178
Figure 11-5:	PMT Optical Filter Bandwidth .....	179
Figure 11-6:	Effects of Focusing Source UV in Sample Chamber.....	180
Figure 11-7:	6200T, Gas Flow .....	184
Figure 11-8:	Location of Critical Flow Orifice .....	185
Figure 11-9:	Flow Control Assembly & Critical Flow Orifice .....	185
Figure 11-10:	6200T Hydrocarbon Scrubber (Kicker) .....	186
Figure 11-11:	6200T Electronic Block Diagram.....	187
Figure 11-12:	CPU Board Annotated .....	189
Figure 11-13:	6200T Sensor Module .....	190
Figure 11-14:	6200T Sample Chamber .....	191
Figure 11-15:	PMT Housing Assembly.....	192
Figure 11-16:	Basic PMT Design .....	189
Figure 11-17:	PMT Cooling System.....	190
Figure 11-18:	PMT Preamp Block Diagram.....	192
Figure 11-19:	Relay Board Status LED Locations .....	194
Figure 11-20:	Power Distribution Block Diagram .....	197
Figure 11-21:	TS1, Front Panel and Display .....	198
Figure 11-22:	TS2, Front Panel and Display .....	198
Figure 11-23:	Front Panel and Display Interface Block Diagram .....	199
Figure 11-24:	Basic Software Operation.....	203
Figure 11-25:	Calibration Slope and Offset .....	208

## LIST OF TABLES

Table 1-1:	Thermocouple Type Distinctions.....	8
Table 2-1	6200T Basic Unit Specifications.....	10
Table 2-2	501TS Converter Specifications.....	11
Table 3-1:	Ventilation Clearance.....	15
Table 3-2:	Display Screen and Touch Control Description.....	17
Table 3-3:	Rear Panel Description—Analyzer and Converter.....	20
Table 3-4:	Electrical Connections References.....	23
Table 3-5:	Analog Input Pin Assignments.....	25
Table 3-6:	Analog Output Pin Assignments.....	25
Table 3-7:	Status Output Signals.....	28
Table 3-8:	Control Input Signals.....	29
Table 3-9:	Zero/Span and Sample/Cal Valve Operating States.....	36
Table 3-10:	IZS Valve Operating States.....	38
Table 3-11:	Possible Startup Warning Messages – 6200T Analyzers w/o Options.....	41
Table 3-12:	Possible Startup Warning Messages – 6200T Analyzers with Options.....	42
Table 4-1:	Analyzer Operating Modes.....	56
Table 4-2:	Test Functions Defined.....	57
Table 4-3:	List of Warning Messages.....	58
Table 4-4:	Primary Setup Mode Features and Functions.....	61
Table 4-5:	Secondary Setup Mode Features and Functions.....	61
Table 5-1:	Password Levels.....	67
Table 5-2:	Variable Names (VARs) Revision G.3.....	70
Table 5-3:	6200T Diagnostic (DIAG) Functions.....	71
Table 6-1:	COMM Port Communication Modes.....	85
Table 6-2:	Ethernet Status Indicators.....	89
Table 6-3:	LAN/Internet Default Configuration Properties.....	90
Table 6-4:	Hostname Editing Button Functions.....	90
Table 8-1:	Status Output Pin Assignments.....	100
Table 8-2:	Control Input Pin Assignments.....	100
Table 8-3:	Terminal Mode Software Commands.....	102
Table 8-4:	Command Types.....	102
Table 8-5:	Serial Interface Documents.....	107
Table 8-6:	AutoCal Modes.....	109
Table 8-7:	AutoCal Attribute Setup Parameters.....	110
Table 8-8:	Example Auto-Cal Sequence.....	110
Table 8-9:	Calibration Data Quality Evaluation.....	112
Table 9-1:	6200T Preventive Maintenance Schedule.....	116
Table 9-2:	Predictive Uses for Test Functions.....	117
Table 10-1:	Warning Messages - Indicated Failures.....	127
Table 10-2:	Test Functions - Possible Causes for Out-Of-Range Values.....	130
Table 10-3:	DC Power Test Point and Wiring Color Code.....	138
Table 10-4:	DC Power Supply Acceptable Levels.....	139
Table 10-5:	Relay Board Control Devices.....	140
Table 10-6:	Analog Output Test Function - Nominal Values.....	141
Table 10-7:	Status Outputs Check Pin Out.....	141
Table 10-8:	Example of HVPS Power Supply Outputs.....	145
Table 10-9:	UV Lamp Signal Troubleshooting.....	157
Table 11-1:	Relay Board Status LED's.....	194
Table 13-1.	6200T, Spares Parts List (Reference:01/07/2020).....	216
Table 13-2.	6200T, 2 Years Recommended Spares List(Reference:01/07/2020).....	216
Table 13-3.	6200T, Annual Maintenance Kit Items.....	<b>Error! Bookmark not defined.</b>

**This page intentionally left blank.**

**PART I**  
**GENERAL INFORMATION**





**This page intentionally left blank.**

# 1. INTRODUCTION, FEATURES AND OPTIONS

This section provides an overview of the Model 6200T Analyzer, its features and its options, followed by a description of how this user manual is arranged.

## 1.1. 6200T Overview

TAI Model 6200T Total Sulfides in CO<sub>2</sub> analyzer, is designed to measure mixed sulfur impurities, collectively referred to as Total Sulfides (TS), in carbon dioxide (CO<sub>2</sub>) gas. Since there is no SO<sub>2</sub> scrubber in the system, the instrument reading is the sum of the reduced sulfur compounds and SO<sub>2</sub>. The 6200T consists of a modified 6400T UV Fluorescence SO<sub>2</sub> Analyzer, with special software, and a 501TS high temperature quartz thermal converter.

The 501TS primarily consists of a heated, temperature-controlled quartz tube. Sulfur compounds are heated to approximately 1000 °C as they pass through the quartz tube and are converted to SO<sub>2</sub>.

Since the gas being analyzed is essentially CO<sub>2</sub>, which generally contains no oxygen, there is an assembly to add approximately 6% oxygen to the sample before it passes through the converter. This dilution of the sample gas is corrected for by the software and calibration procedure. The added oxygen allows the sulfur compounds to be oxidized to SO<sub>2</sub> making the 6200T respond to the total number of sulfur molecules in the sample gas. Any SO<sub>2</sub> present in the sample is unaffected by the converter and adds to the measured concentration. The sample gas then passes to a modified 6400T analyzer where the SO<sub>2</sub> and converted compounds are analyzed as SO<sub>2</sub>.

Figure 1-1: 6200T, Basic Design

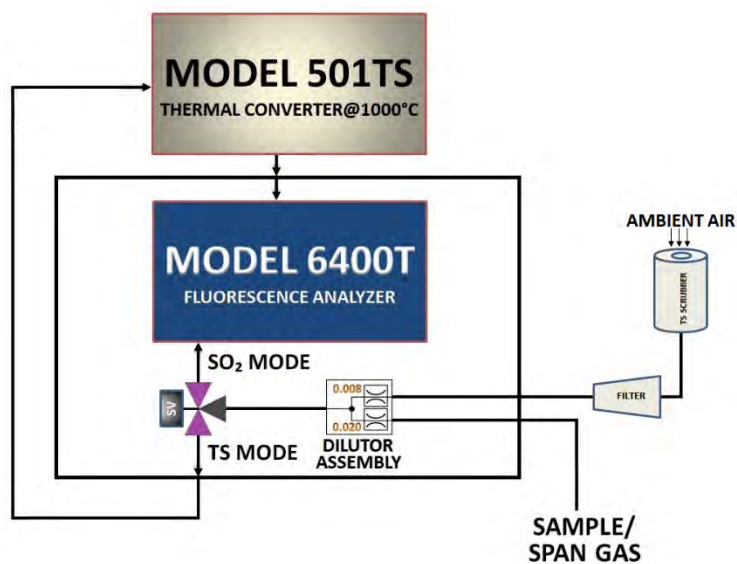

The 6200T consists of two major assemblies: a modified 6400T SO<sub>2</sub> analyzer and an M501TS thermal converter. The Model 6200T is a microprocessor controlled UV Fluorescence Total Sulfur Analyzer used to measure the total sulfur (TS) concentration as sulfur dioxide (SO<sub>2</sub>) after first thermally converting the sulfur components of the sample gas to SO<sub>2</sub>. When operating in TS mode, sample is drawn into the analyzer and passed to the thermal converter. After conversion, the sample returns to the analyzer and is drawn through the instrument's sample chamber where it is exposed to ultraviolet light, which causes any SO<sub>2</sub> present to fluoresce. The analyzer measures the amount of fluorescence to determine the amount of SO<sub>2</sub> present in the sample gas. In SO<sub>2</sub> mode, the analyzer measures the sample without sending it through the converter, hence only SO<sub>2</sub> is measured. The mode is user switchable from the touch screen display panel.

The 6200T's exceptional stability is achieved with the use of an optical shutter to compensate for sensor drift and a reference detector to correct for changes in UV lamp intensity. Additionally an advanced optical design combined with a special scrubber, called a "kicker" that removes hydrocarbons (which fluoresces similarly to SO<sub>2</sub>) prevents inaccuracies due to interferences.



Calibration of the instrument is performed in software which stores SO<sub>2</sub> concentration measurements made when specific, known concentrations of SO<sub>2</sub> are supplied to the analyzer. The microprocessor uses these calibration values along with other performance parameters, such as the sensor offset, UV lamp intensity, and the amount of stray light present, along with measurements of the temperature and pressure of the sample gas to compute the final SO<sub>2</sub> concentration.

Built-in data acquisition capability, using the analyzer's internal memory, allows the logging of multiple parameters including averaged or instantaneous concentration values, calibration data, and operating parameters such as pressure and flow rate. Stored data are easily retrieved through the serial port or optional Ethernet port via Teledyne's APICOM software or from the front panel, allowing operators to perform predictive diagnostics and enhanced data analysis by tracking parameter trends. Multiple averaging periods of one minute to 365 days are available for over a period of one year.

## 1.2. Features

The features of your 6200T UV Fluorescence Sulfur Dioxide Analyzer include:

- LCD Graphical User Interface with capacitive touch screen
- Ranges, 0-50 ppb to 0-20,000 ppb, user selectable
- Microprocessor control for versatility
- Multi-tasking software to allow viewing test variables while operating
- Continuous self checking with alarms
- Bi-directional USB, RS-232, and 10/100Base-T Ethernet ports for remote operation
- Front panel USB ports for peripheral devices
- Digital status outputs to indicate instrument operating condition
- Adaptive signal filtering to optimize response time
- Temperature and Pressure compensation
  - Internal Zero and Span check (optional)
  - Internal data logging with 1 minute to 365 day multiple averages
  - Critical flow orifices to provide flow stability

## 1.3. Configurations

There are two configurations available:

The standard unit consists of:

- A modified 6400T Fluorescent SO<sub>2</sub> Analyzer
- The M501TS High Temperature Thermal Converter
- External Span, Internal Zero with High-performance Charcoal Scrubber for Zero.

See Figure 1-2 for the pneumatic diagram, and Section 1.4 for details on the M501TS.

Another configuration consists of:

- Standard unit (described above)
- Internal Zero/Span (IZS) Option with H<sub>2</sub>S permeation tube.

The IZS option uses sample gas (passed through a special, high-performance charcoal scrubber) to dilute H<sub>2</sub>S from the perm tube for span calibration checks. See Figure 1- for the pneumatic diagram.

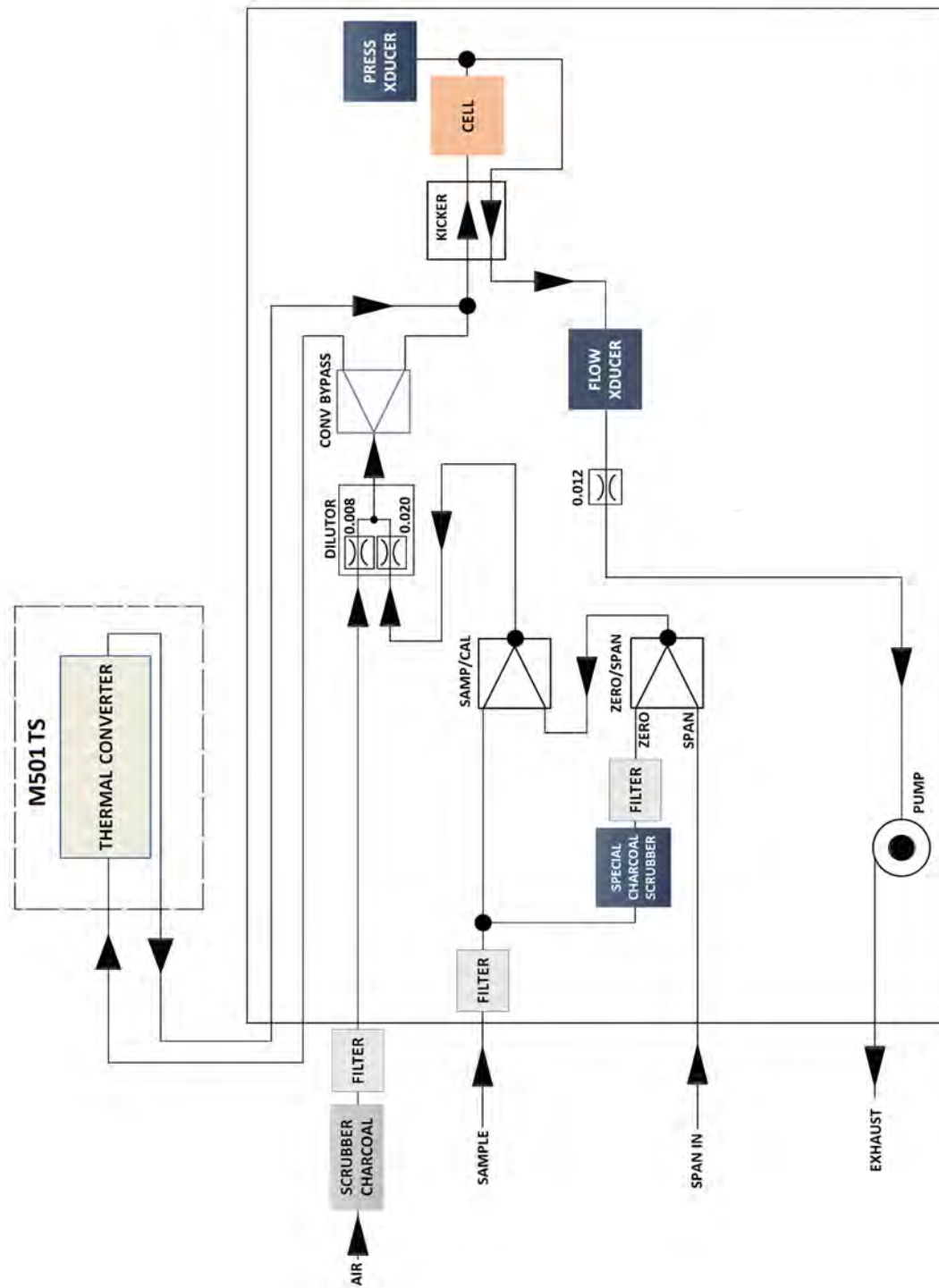

Figure 1-2: 6200T Basic Configuration



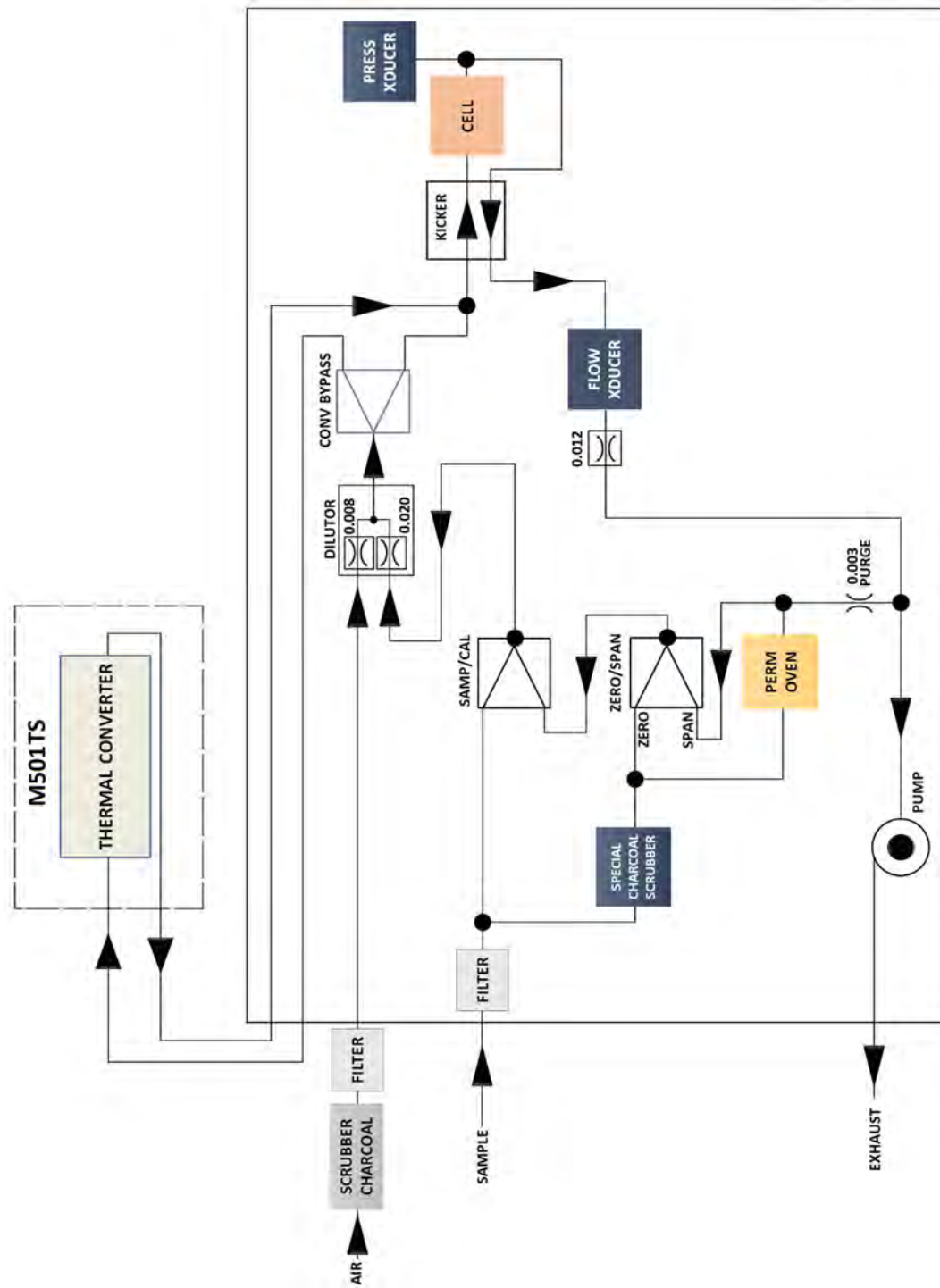

Figure 1-3: 6200T with IZS/Permeation Tube Option

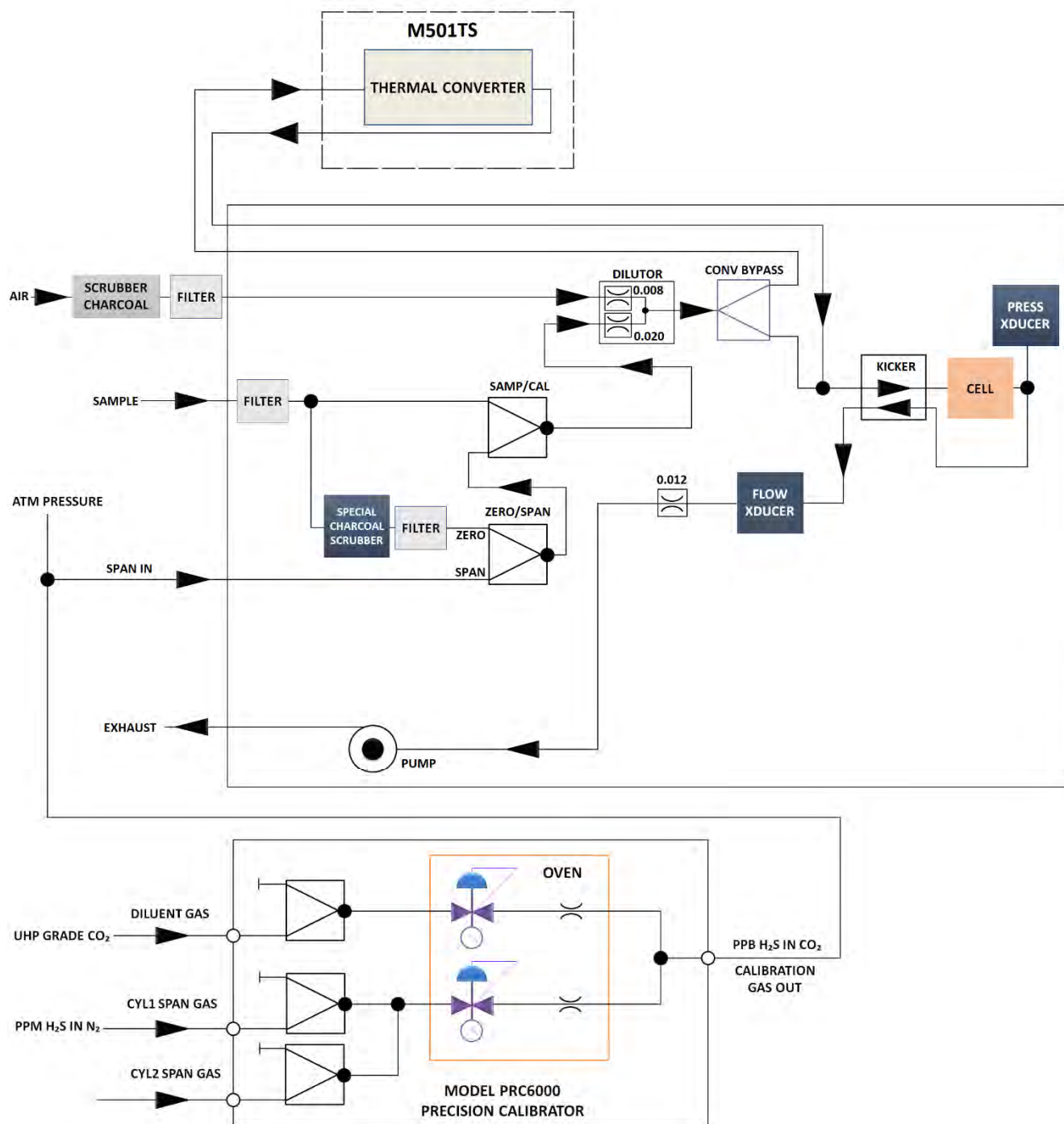

Figure 1-4: 6200T with PRC6000, Precision Calibrator

*CO<sub>2</sub> liquefies when compressed, and sulfur compounds do not stay dissolved in liquid CO<sub>2</sub>. Therefore, it is not practical to use compressed gas bottles of H<sub>2</sub>S in CO<sub>2</sub> for calibration purposes. TAI strongly recommends that H<sub>2</sub>S in N<sub>2</sub> bottles be used for calibration of the 6200T, and that a calibrator be used to mix zero gas (CO<sub>2</sub>) into the cal gas stream, making the final calibration gas mostly CO<sub>2</sub>.*



## 1.4. The M501TS – Total Reduced Sulfur Converter

The M501TS oxidizes reduced sulfur compounds to SO<sub>2</sub> in a high temperature quartz oven. A front-panel-mounted, programmable digital temperature controller regulates power to the heater. Power to the heater is switched by a solid state, zero-crossing relay. An over/under-temperature alarm contact closure is located on the rear panel. The alarm set point is adjustable in the temperature controller. The heater temperature is sensed by a Type S (distinguished from other thermocouple types by its wire colors, red and black; see table below) (Platinum-Rhodium) thermocouple probe inserted in the bore alongside the quartz tube. Note: If using a type K or N thermocouple, or if switching to a type S thermocouple, please refer to Section 10.7.4 for installation and proper controller configuration.

The quartz tube carrying the sample mixture runs through the core of the heater and is heated by radiation from electrical heating elements at the heater bore surface. See Figure 1- for a layout view of the converter.

**Table 1-1: Thermocouple Type Distinctions**

Thermocouple Type	Indicated by Wire Color
S	Red and Black
K	Red and Yellow
N	Red and Orange



**WARNING!**

**ENSURE PROPER LINE VOLTAGE IS SELECTED PRIOR TO PLUGGING UNIT INTO POWER SOURCE**



**CAUTION!**

**THE QUARTZ TUBE AND HEATER ARE VERY HOT DO NOT TOUCH**



**CAUTION!**

**ENSURE THAT YOU SELECT THE CORRECT SETTINGS FOR THE THERMOCOUPLE TYPE THAT YOU HAVE**

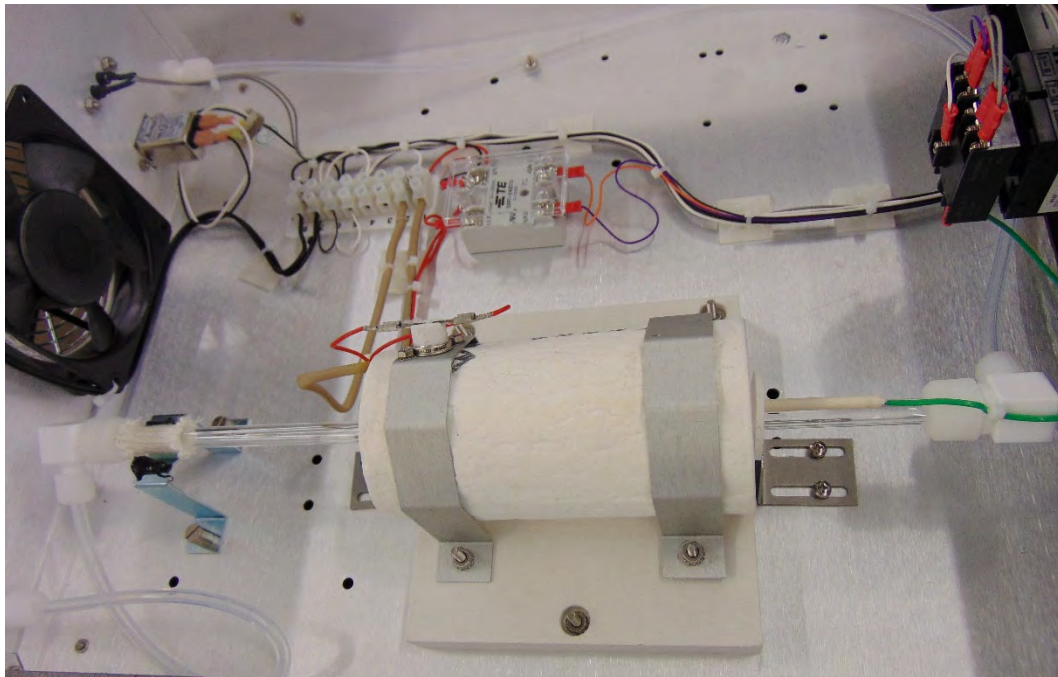

Figure 1-5: 501TS, Component Layout, 110VAC Configuration

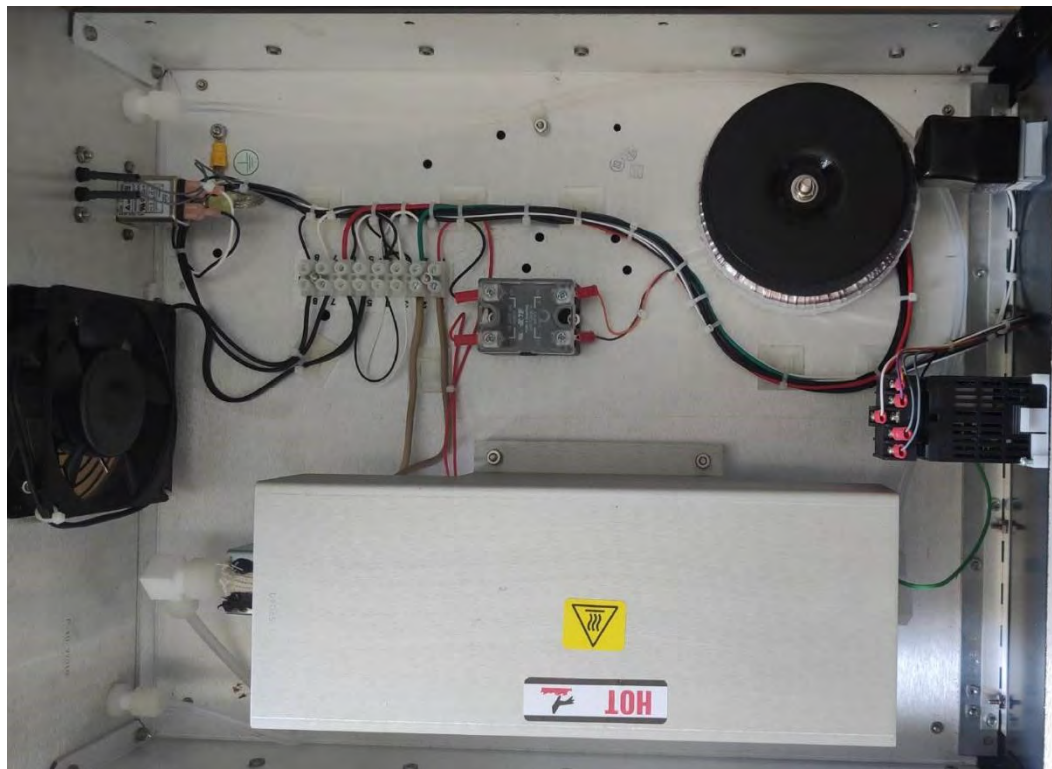

Figure 1-6: 501TS, Component Layout, 220VAC Configuration





## 2. SPECIFICATIONS, APPROVALS & COMPLIANCE

This section presents specifications for the 6200T analyzer and Agency approvals, EPA equivalency designation, and CE mark compliance.

### 2.1. Specifications and Approvals

**Table 2-1: 6200T Basic Unit Specifications**

Parameter	Description
Ranges (Physical Analog Output)	Min: 0-50 ppb Full Scale Max: 0-20,000 ppb Full Scale (selectable, dual ranges and auto ranging supported)
Measurement Units	ppb, ppm, $\mu\text{g}/\text{m}^3$ , $\text{mg}/\text{m}^3$ (selectable)
Zero Noise <sup>1</sup>	< 0.2 ppb (RMS)
Span Noise <sup>1</sup>	< 0.5% of reading, above 50 ppb
Lower Detectable Limit <sup>2</sup>	0.4 ppb
Zero Drift	< 0.5 ppb/24 hours
Span Drift	< 0.5% of full scale/24 hours
Lag Time <sup>1</sup>	20 seconds
Rise/Fall Time <sup>1</sup>	<100 sec to 95%
Linearity	1% of full scale
Precision <sup>1</sup>	0.5% of reading above 50 ppb
Sample Flow Rate	650 $\text{cm}^3/\text{min}$ . $\pm 10\%$
Power Requirements	100V-120V, 220V-240 V, 50/60 Hz
Analog Output Ranges	10 V, 5 V, 1 V, 0.1 V (selectable)
Recorder Offset	$\pm 10\%$
Standard I/O	1 Ethernet: 10/100Base-T 2 RS-232 (300 – 115,200 baud) 2 USB device ports 8 opto-isolated digital outputs 6 opto-isolated digital inputs 4 analog outputs
Optional I/O	8 analog inputs (0-10V, 12-bit) 4 digital alarm outputs
Environmental	Installation category (over-voltage category) II; Pollution degree 2
Operating Temperature Range	5 - 40 °C (with EPA Equivalency)
Humidity Range	0 - 95% RH, non-condensing
Dimensions HxWxD	7" x 17" x 23.5" (178 mm x 432 mm x 597 mm)
Weight	31 lbs (14 kg) 35.7 lbs (16 kg) with internal pump
Certifications	EN61326 (1997 w/A1: 98) Class A, FCC Part 15 Subpart B Section 15.107 Class A, ICES-003 Class A (ANSI C63.4 1992) & AS/NZS 3548 (w/A1 & A2; 97) Class A. IEC 61010-1:90 + A1:92 + A2:95,
Approvals	North American: cNEMKO (Canada): can/csa-c22.2 No. 61010-1-04, NEMKO-CCL (US): UL No. 61010-1 (2 <sup>nd</sup> Edition) US EPA: EQSA-0495-100 MCERTS: Sira MC 050067/04 EN14212, Approved, CE and Others
<sup>1</sup> As defined by the USEPA.	
<sup>2</sup> Defined as twice the zero noise level by the USEPA.	

Table 2-2: M501TS Converter Specifications

Specification	Value	Unit
Maximum Flow Rate	1000	cc/min
Nominal Flow Rate (CO <sub>2</sub> )	625	cc/min
Nominal Flow Rate (Air/N <sub>2</sub> )	450	cc/min
Maximum TS Concentration for specified conversion efficiency	20	ppmv
Minimum Conversion Efficiency (In CO <sub>2</sub> matrix)		%
H <sub>2</sub> S	98	
COS, CS <sub>2</sub>	90	
Least Discernible Level (LDL)	See 6400T Manual	
Operating Converter Temperature	1000	° C
Maximum Converter Temperature	1050	° C
Power	100-120/220-240 VAC 50/60 Hz, 440 watts	
Weight	24 (11)	lbs. (kg)
Dimensions	7 x 17 x 22 (178 x 432 x 559)	inches (mm)

## 2.2. EPA Equivalency Designation

The 6200T Analyzer is designated as Reference Method Number EQSA-0495-100 as per 40 CFR Part 53 when operated under the following conditions:

- Range: Any range from 50 parts per billion (ppb) to 10 parts per million (ppm)
- Ambient temperature range of 5°C to 40°C
- Line voltage range of 100-120 VAC or 220-240 VAC, at 50 or 60 Hz
- Sample filter: Equipped with PTFE filter element in the internal filter assembly
- Sample flow of 650 +/- 65 cm<sup>3</sup>/min
- Vacuum pump (internal) capable of 14" Hg Absolute pressure @ 1 slpm or better
- Software settings:

Dynamic span	OFF
Dynamic zero	OFF
Dilution factor	OFF
AutoCal	ON or OFF
Dual range	ON or OFF
Auto-range	ON or OFF
Temp/Pressure compensation	ON

Under this designation, the analyzer may be operated with or without the following optional equipment:

- Rack mount with chassis slides
- Rack mount without slides, ears only



- Internal zero/span (IZS) option with either:
- SO<sub>2</sub> permeation tube - 0.4ppm at 0.7 liter per minute; certified/uncertified, or
- SO<sub>2</sub> permeation tube - 0.8 ppm at 0.7 liter per minute; certified/uncertified. Under the designation, the IZS option cannot be used as the source of calibration
- 4-20mA isolated analog outputs
- Status outputs
- Control inputs
- RS-232 output
- Ethernet output
- Zero air scrubber

## 2.3. CE Mark Compliance

This section presents emissions and safety compliance information.

### 2.3.1. Emissions Compliance

The Teledyne UV Fluorescence SO<sub>2</sub> Analyzer 6200T was tested and found to be fully compliant with:

EN61326 (1997 w/A1: 98) Class A, FCC Part 15 Subpart B Section 15.107 Class A, ICES-003 Class A (ANSI C63.4 1992) & AS/NZS 3548 (w/A1 & A2; 97) Class A.

### 2.3.2. Safety Compliance

The Teledyne-Advanced Pollution Instrumentation UV Fluorescence SO<sub>2</sub> Analyzer 6200T was tested and found to be fully compliant with:

IEC 61010-1:2001,

Issued by CKC Laboratories on 4 April 2003, Report Number WO-80146.

**This page intentionally left blank.**



### 3. GETTING STARTED

This section addresses the procedures for unpacking the instrument and inspecting for damage, presents clearance specifications for proper ventilation, introduces the instrument layout, then presents the procedures for getting started: making electrical and pneumatic connections, and conducting an initial calibration check.

#### 3.1. Unpacking the 6200T Analyzer



**CAUTION**  
**GENERAL SAFETY HAZARD**

To avoid personal injury, always use two persons to lift and carry the 6200T.

**ATTENTION**

**COULD DAMAGE INSTRUMENT AND VOID WARRANTY**

Printed Circuit Assemblies (PCAs) are sensitive to electro-static discharges too small to be felt by the human nervous system. Failure to use ESD protection when working with electronic assemblies will void the instrument warranty. Refer to Section 11 for more information on preventing ESD damage.



**CAUTION**

Do not operate this instrument until you've removed dust plugs from SAMPLE and EXHAUST ports on the rear panel!

**Note**

Teledyne Analytical Instruments recommends that you store shipping containers/materials for future use if/when the instrument should be returned to the factory for repair and/or calibration service. See Warranty section in this manual on page ii. Contact TAI at: <http://www.teledyne-ai.com> for obtaining a Return Authorization.

Verify that there is no apparent external shipping damage. If damage has occurred, please advise the shipper first, then Teledyne Analytical Instruments.

Included with your analyzer is a printed record of the final performance characterization performed on your instrument at the factory. It is titled *Final Test and Validation Data Sheet (P/N 04551)*. This record is an important quality assurance and calibration record for this instrument. It should be placed in the quality records file for this instrument.



**WARNING**  
**ELECTRICAL SHOCK HAZARD**

Never disconnect PCAs, wiring harnesses or electronic subassemblies while under power.

### 3.1.1. Ventilation Clearance

Whether the analyzer /converter are set up on a bench or installed into an instrument rack, be sure to leave sufficient ventilation clearance.

**Table 3-1: Ventilation Clearance**

AREA	MINIMUM REQUIRED CLEARANCE
Back of the instrument	<b>4 in.</b>
Sides of the instrument	<b>1 in.</b>
Above and below the instrument	<b>1 in.</b>

Various rack mount kits are available for this analyzer. Contact Customer Service for more information.

## 3.2. Instrument Layout

Instrument layout includes front panel and display, rear panel connectors, and internal chassis layout.

### 3.2.1. Front Panel

Figure 3-1 shows the analyzer's front panel layout, followed by a close-up of the display screen in

Figure 3-2, which is described in Table 3-2. The two USB ports on the front panel are provided for the connection of peripheral devices:

- Plug-in mouse (not included) to be used as an alternative to the touchscreen interface.
- Thumb drive (not included) to download updates to instruction software (contact TAI Customer Service for information).



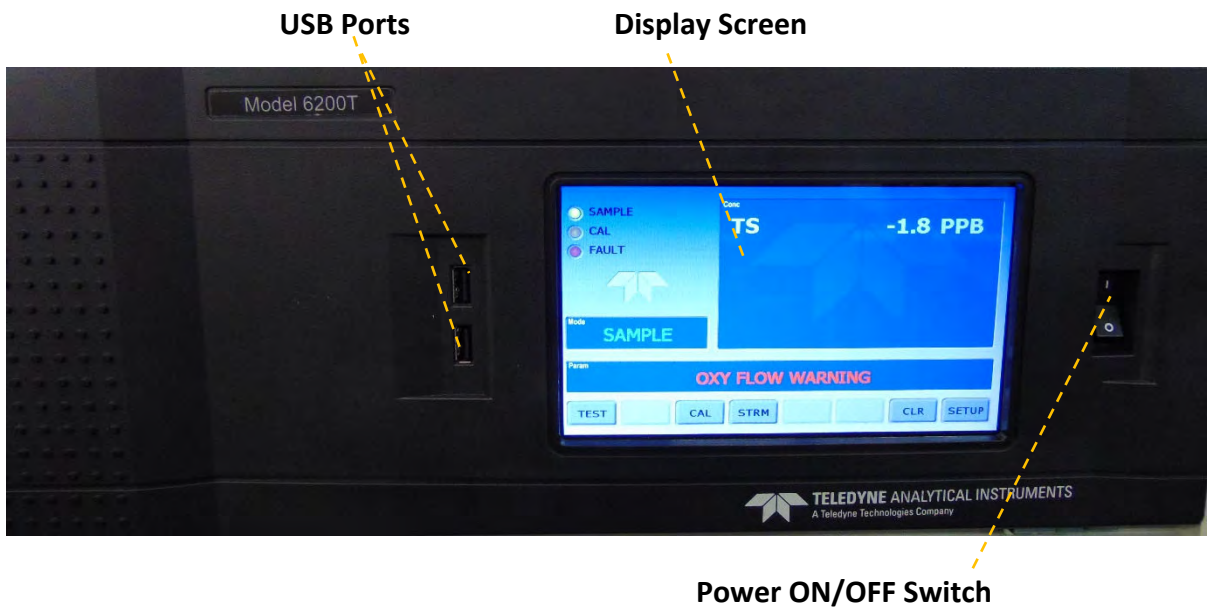

Figure 3-1: Front Panel Layout

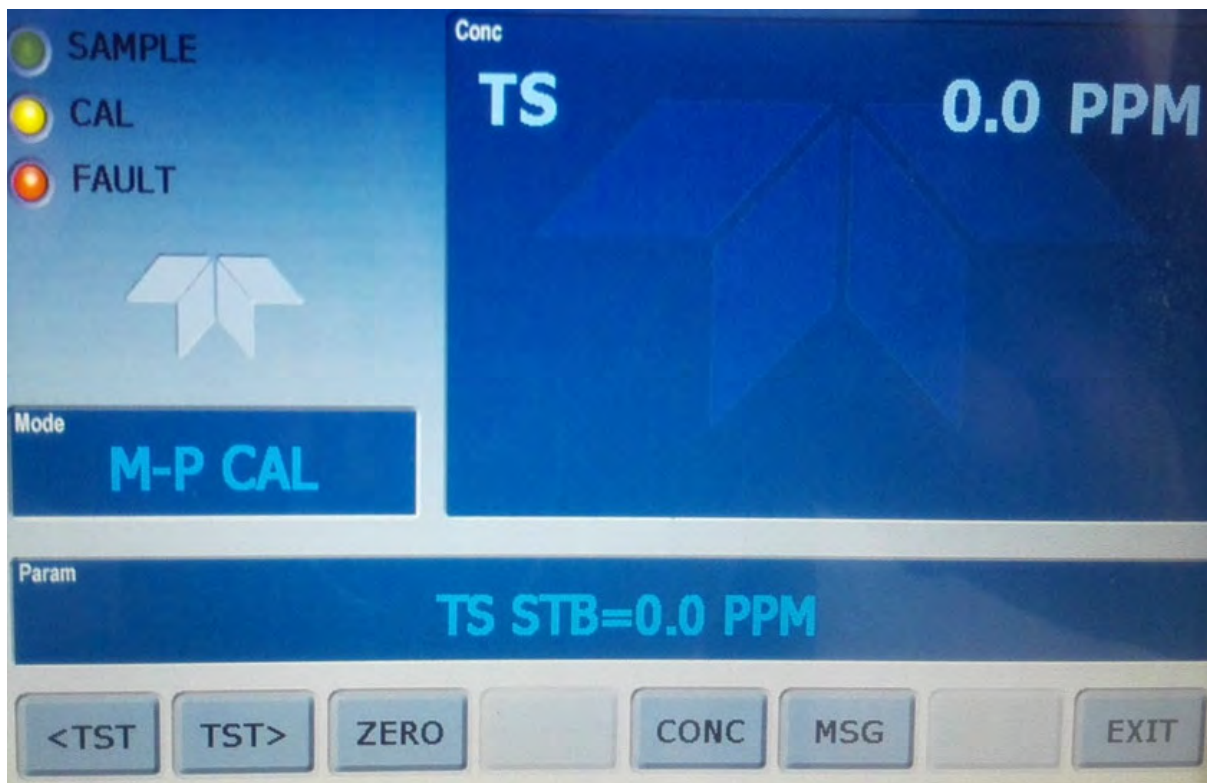

Figure 3-2: Display Screen and Touch Control

The analyzer's front panel liquid crystal display screen includes touch control. Upon analyzer start-up, the screen shows a splash screen and other initialization indicators before the main display appears, similar to

Figure 3-2 above (may or may not display a Fault alarm). The LEDs on the display screen indicate the Sample, Calibration and Fault states; also on the screen is the gas concentration field (Conc), which displays real-time readouts for the primary gas and for the secondary gas if installed. The display screen also shows what mode the analyzer is currently in, as well as messages and data (Param). Along the bottom of the screen is a row of touch control buttons; only those that are currently applicable will have a label. Table 3-2 provides detailed information for each component of the screen.

**ATTENTION****-----  
COULD DAMAGE INSTRUMENT AND VOID WARRANTY**

**Do not use hard-surfaced instruments such as pens to touch the control buttons.**  
-----

**Table 3-2: Display Screen and Touch Control Description**

Field	Description/Function			
Status	LEDs indicating the states of Sample, Calibration and Fault, as follows:			
	Name	Color	State	Definition
	SAMPLE	Green	Off	Unit is not operating in sample mode, DAS is disabled.
			On	Sample Mode active; Front Panel Display being updated; DAS data being stored.
			Blinking	Unit is operating in sample mode, front panel display being updated, DAS hold-off mode is ON, DAS disabled
CAL	Yellow	Off	Auto Cal disabled	
		On	Auto Cal enabled	
		Blinking	Unit is in calibration mode	
FAULT	Red	Off	No warnings exist	
		Blinking	Warnings exist	
Conc	Displays the actual concentration of the sample gas currently being measured by the analyzer in the currently selected units of measure			
Mode	Displays the name of the analyzer's current operating mode			
Param	Displays a variety of informational messages such as warning messages, operational data, test function values and response messages during interactive tasks.			
Control Buttons	Displays dynamic, context sensitive labels on each button, which is blank when inactive until applicable.			

Figure 3-3 shows how the front panel display is mapped to the menu charts illustrated in this manual. The **Mode**, **Param** (parameters), and **Conc** (gas concentration) fields in the display screen are represented across the top row of each menu chart. The eight touch **control buttons** along the bottom of the display screen are represented in the bottom row of each menu chart.





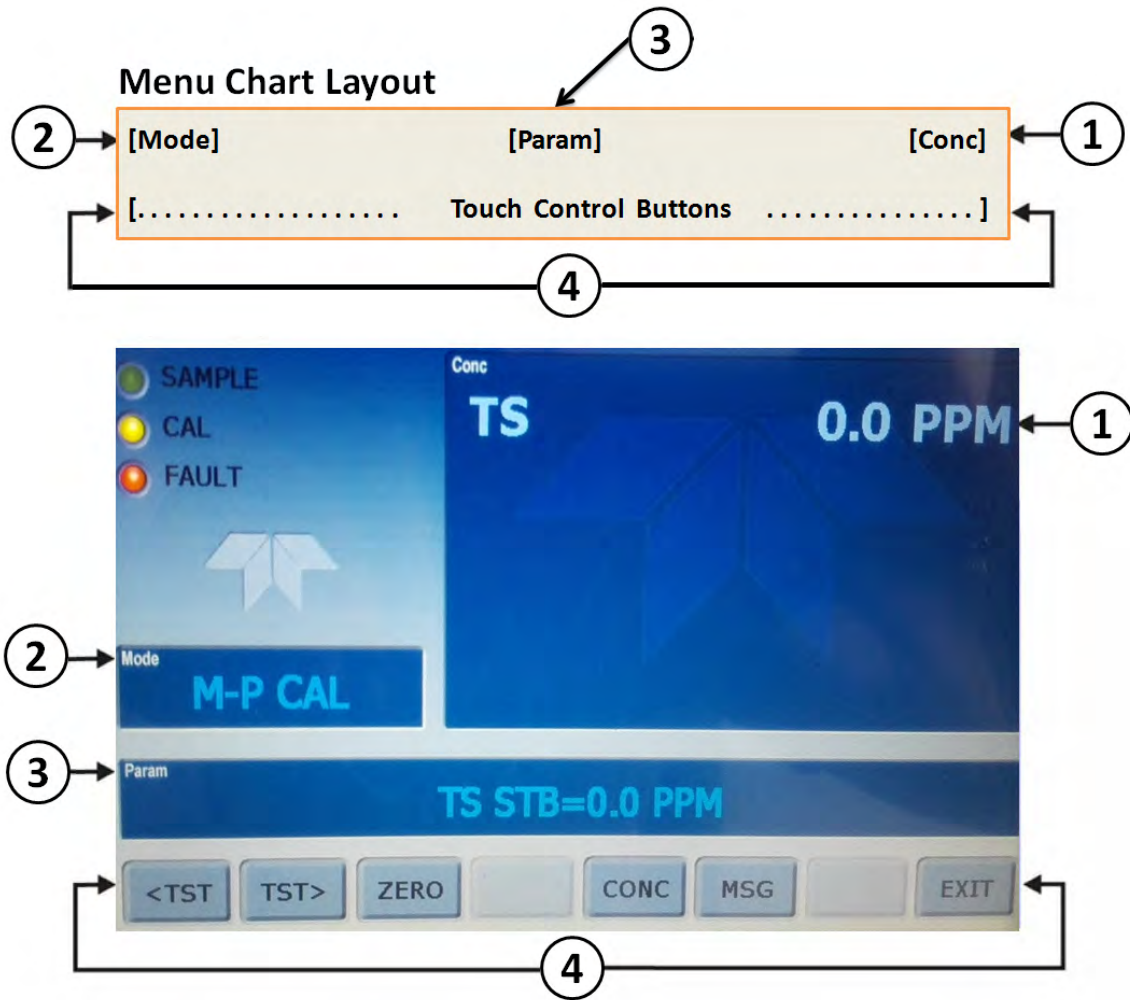

Figure 3-3: Display/Touch Control Screen Mapped to Menu Charts

**Note**

The menu charts in this manual contain condensed representations of the analyzer’s display during the various operations being described. These menu charts are not intended to be exact visual representations of the actual display.

The front panel of the converter includes the OFF/ON power switch plus the controls for the Fuji Electric PXZ Series temperature controller for maintaining proper thermal control within the quartz tube.

The controller has been set up at the factory. Should further adjustments be necessary, instructions are briefly stated in Sections 3.4.1.2 and 3.4.1.3.

To view the actual temperature, PV – Present Value, or the set point value, SV – Set-point Value, press the PV/SV button in the lower left corner of the controller.

### 3.2.2. Rear Panel

Figure 3-4: Rear Panel Layout—Converter and Analyzer

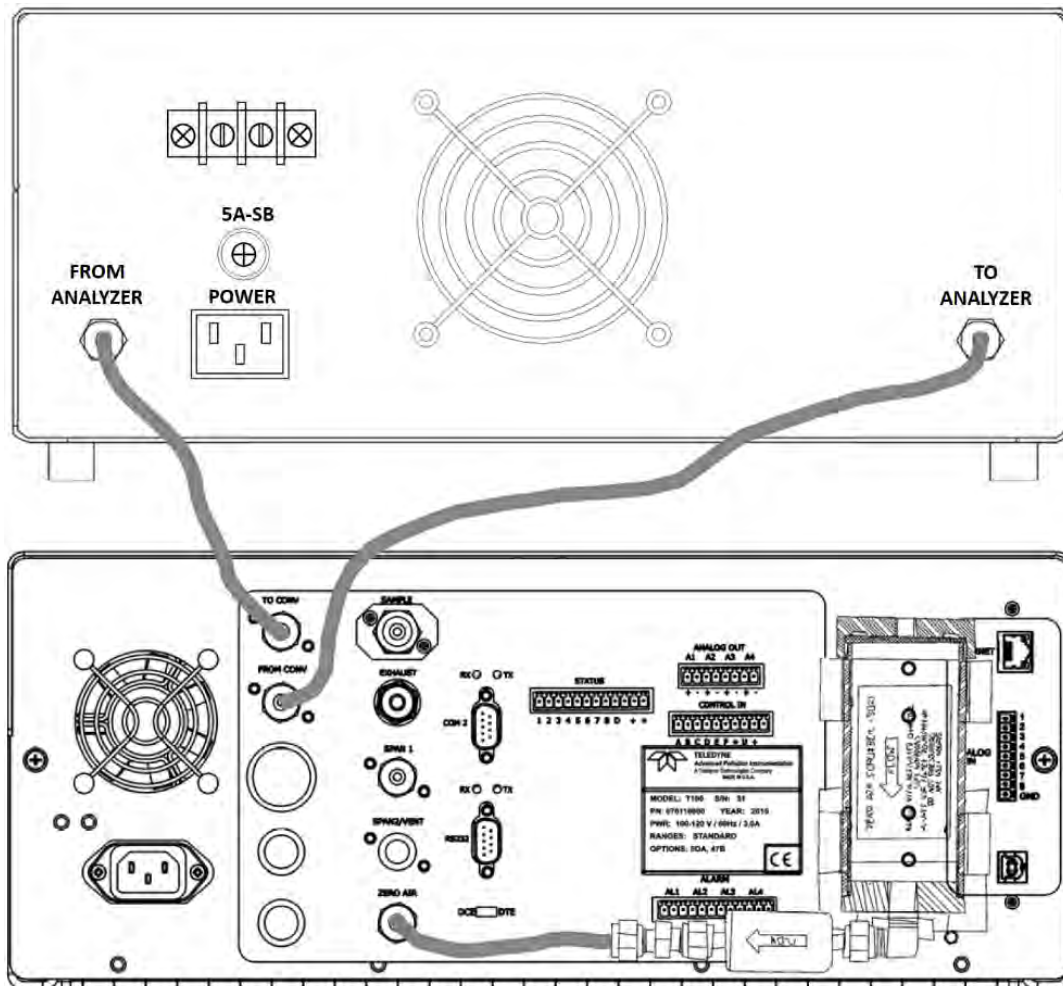



Table 3-3 provides a description of each component on the rear panel.



Table 3-3: Rear Panel Description—Analyzer and Converter

Component	Function
Cooling fans	Pulls ambient air into chassis through side vents and exhausts through rear.
 AC power connector	Connector for three-prong cord to apply AC power to the analyzer. <b>CAUTION! The cord's power specifications (specs) MUST comply with the power specs on the analyzer's rear panel Model number label</b>
Model/specs label	Identifies the analyzer model number and provides power specs
TO CONV	Passes sample from analyzer to converter. (Use Teflon tubing only)
FROM CONV	Returns converted sample to analyzer for analysis. (Use Teflon tubing only)
SAMPLE	Connect a gas line from the source of sample gas here. Calibration gases are also inlet here on units without zero/span/shutoff valve options installed.
EXHAUST	Connect an exhaust gas line of not more than 10 meters long here that leads outside the shelter or immediate area surrounding the instrument.
SPAN 1	Connect a gas line to the source of calibrated span gas here.
ZERO AIR	Internal Zero Air: On units with no internal zero air scrubber attach a gas line to the source of zero air here.
RX TX	LEDs indicate receive (RX) and transmit (TX) activity on the when blinking.
COM 2	Serial communications port for RS-232 or RS-485.
RS-232	Serial communications port for RS-232 only.
DCE DTE	Switch to select either data terminal equipment or data communication equipment during RS-232 communication. (Section 6.1).
STATUS	For outputs to devices such as Programmable Logic Controllers (PLCs).
ANALOG OUT	For voltage or current loop outputs to a strip chart recorder and/or a data logger.
CONTROL IN	For remotely activating the zero and span calibration modes.
ALARM	Option for concentration alarms and system warnings.
ETHERNET	Connector for network or Internet remote communication, using Ethernet cable
ANALOG IN	Option for external voltage signals from other instrumentation and for logging these signals
USB	Connector for direct connection to personal computer, using USB cable.
Information Label	Includes voltage and frequency specifications

Internal Chassis Layout Figure 3-5A illustrates the internal layout of the Analyzer chassis without options while Figure 3-5B shows the internal layout of the M500TS Converter. Section 3.3.2 shows pneumatic diagrams for the basic configuration and for options.

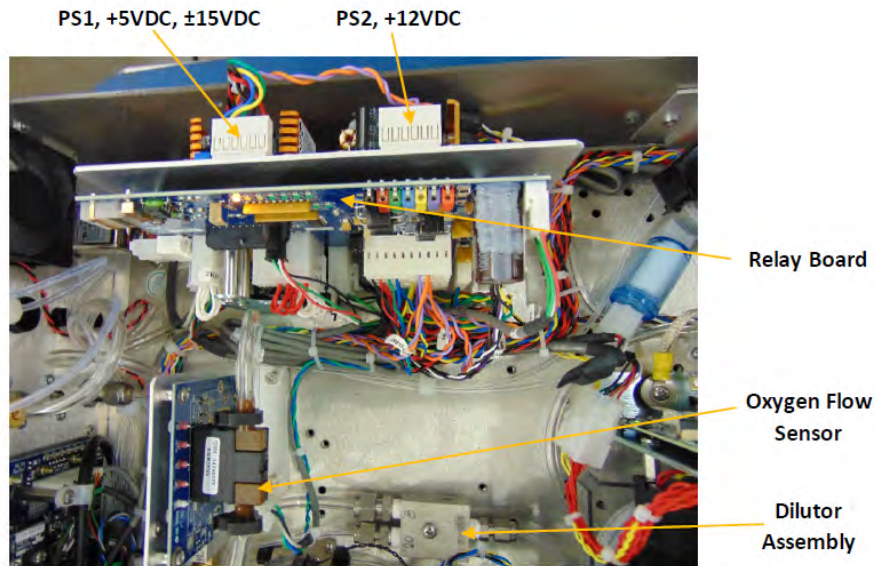
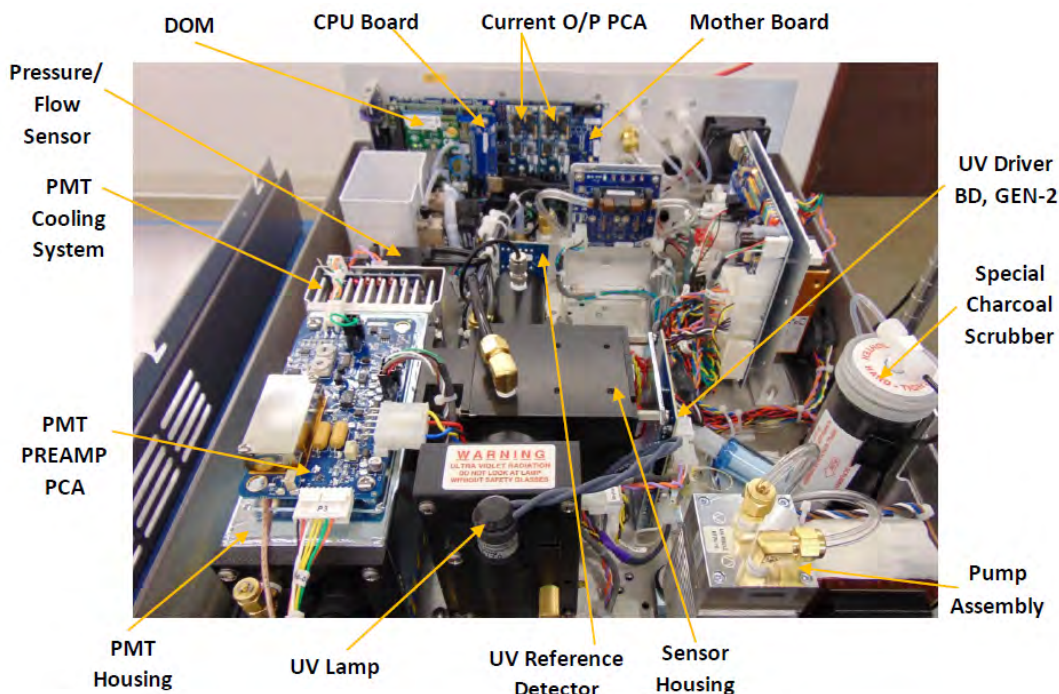
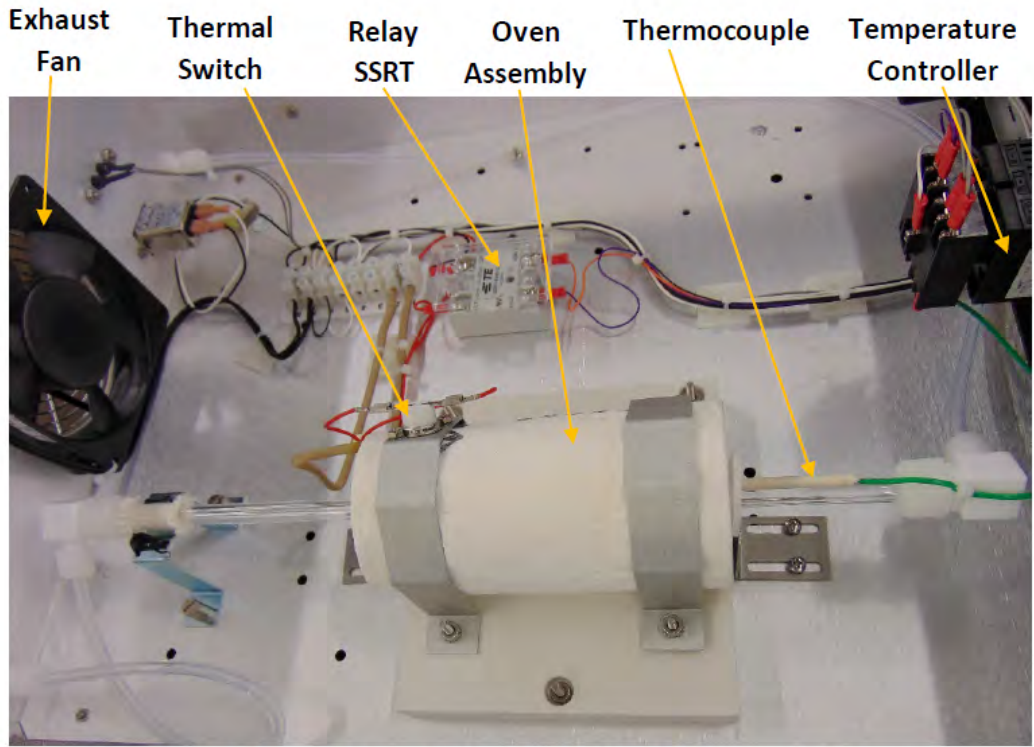
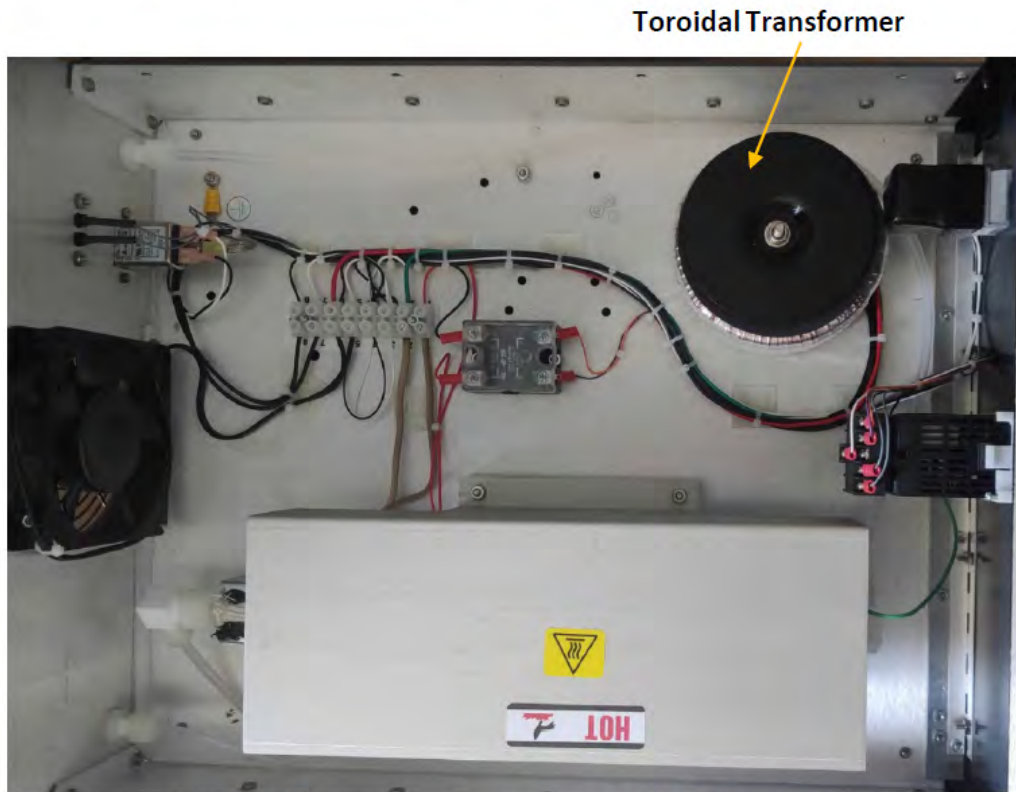

Figure 3-5: 6200T, Internal Layout





501TS, Component Layout, 110VAC Configuration



501TS, Component Layout, 220VAC Configuration

Figure 3-6. M501TS Converter Layout

### 3.3. Connections and Setup

This section presents the electrical (Section 3.3.1) and pneumatic (Section 3.3.2) connections for setup and preparing for instrument operation.

#### 3.3.1. Electrical Connections

**Note**

To maintain compliance with EMC standards, it is required that the cable length be no greater than 3 meters for all I/O connections, which include Analog In, Analog Out, Status Out, Control In, Ethernet/LAN, USB, and RS-232.

This section provides instructions for basic connections and for options. Table 3-4 provides a direct link to the instructions for the subsections that apply to your analyzer's configuration.

**Table 3-4: Electrical Connections References**

Connection	Section
Power	3.3.1.1
Analog Inputs (Option)	3.3.1.2
Analog Outputs	3.3.1.3
Status Outputs	3.3.1.4
Control Inputs	3.3.1.5
Concentration Alarm Relay (Option)	3.3.1.6
Communications (Ethernet, USB, RS-232, Multidrop, RS-485)*	3.3.1.7
* USB is an option with exceptions. * RS-485 is an option and requires special setup (contact the Factory). Either USB or RS-485 can be used; not both.	



### 3.3.1.1. Connecting Power

Attach the power cords to the analyzer and converter and plug them into a power outlet capable of carrying at least 10 Amps of current at your AC voltage and that it is equipped with a functioning earth ground. The converter will take 1 hour to reach setpoint and stabilize.



**WARNING**  
**ELECTRICAL SHOCK HAZARD**

High Voltages are present inside the analyzer and converter cases.  
Power connection must have functioning ground connection.  
Do not defeat the ground wire on power plug.  
Power off analyzer before disconnecting or connecting electrical subassemblies.  
Do not operate analyzer or converter with the cover off.



**CAUTION**  
**GENERAL SAFETY HAZARD**

The 6200T can be configured for both 100-120 V and 220-240 V at either 50 or 60 Hz. To avoid damage to your analyzer, ensure that the AC power voltage matches the voltage indicated on the Analyzer's model identification label (refer to Figure 3-4) before plugging the 6200T into line power.

### 3.3.1.2. Connecting Analog Inputs (Option)

The Analog In connector is used for connecting external voltage signals from other instrumentation (such as meteorological instruments) and for logging these signals in the analyzer's internal DAS. The input voltage range for each analog input is 1-10 VDC.

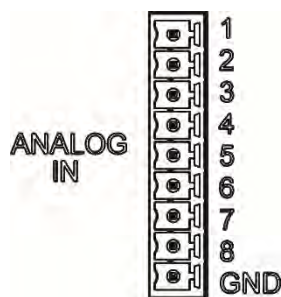

Figure 3-7: Analog In Connector

Pin assignments for the Analog In connector are presented in Table 3-5 .

**Table 3-5: Analog Input Pin Assignments**

PIN	DESCRIPTION	DAS PARAMETER <sup>1</sup>
1	Analog input # 1	AIN 1
2	Analog input # 2	AIN 2
3	Analog input # 3	AIN 3
4	Analog input # 4	AIN 4
5	Analog input # 5	AIN 5
6	Analog input # 6	AIN 6
7	Analog input # 7	AIN 7
8	Analog input # 8	AIN 8
GND	Analog input Ground	N/A

<sup>1</sup> See Section 0 for details on setting up the DAS.

### 3.3.1.3. Connecting Analog Outputs

The 6200T is equipped with several analog output channels accessible through a connector on the rear panel of the instrument. The default configuration for A1 and A2 outputs is 4-20 mA DC. A2 can be configured as a 0-5 VDC output. The analog outputs are user configurable. Refer to the addendum Configurable Analog Output.

When the instrument is in its default configuration, channels A1 and A2 output a signal that is proportional to the SO<sub>2</sub> concentration of the sample gas. Either can be used for connecting the analog output signal to a chart recorder or for interfacing with a datalogger.

To access these signals attach a strip chart recorder and/or data-logger to the appropriate analog output connections on the rear panel of the analyzer.

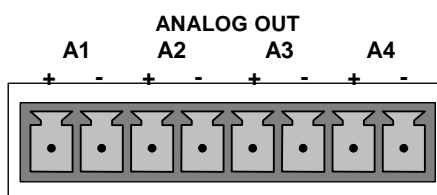
**Figure 3-8: Analog Output Connector****Table 3-6: Analog Output Pin Assignments**

PIN	ANALOG OUTPUT	VOLTAGE SIGNAL	CURRENT SIGNAL
1	A1	V Out	I Out +
2		Ground	I Out -
3	A2	V Out	I Out +
4		Ground	I Out -
5	A3	V Out	I Out +
6		Ground	I Out -
7	A4	V Out	[not available]
8		Ground	[not available]





**CURRENT LOOP ANALOG OUTPUTS (OPTION 41) SETUP**

If your analyzer had this option installed at the factory, there are no further connections to be made. The current loop option can be configured for any output range between 0 and 20 mA.

This section provides instructions for setting up the analog outputs for voltage and/or current output. Figure 3-7A provides installation instructions and illustrates a sample combination of one current output and two voltage outputs configuration.

- For current output install the Current Loop option PCA on J19, on J21 or on J23 of the motherboard.
- For voltage output, install jumpers on J19, J21 and/or J23.

Following Figure 3-8 are instructions for converting current loop analog outputs to standard 0-to-5 VDC outputs.



**CAUTION – AVOID INVALIDATING WARRANTY**

Servicing or handling of circuit components requires electrostatic discharge protection (ESD), i.e. ESD grounding straps, mats and containers. Failure to use ESD protection when working with electronic assemblies will void the instrument warranty.

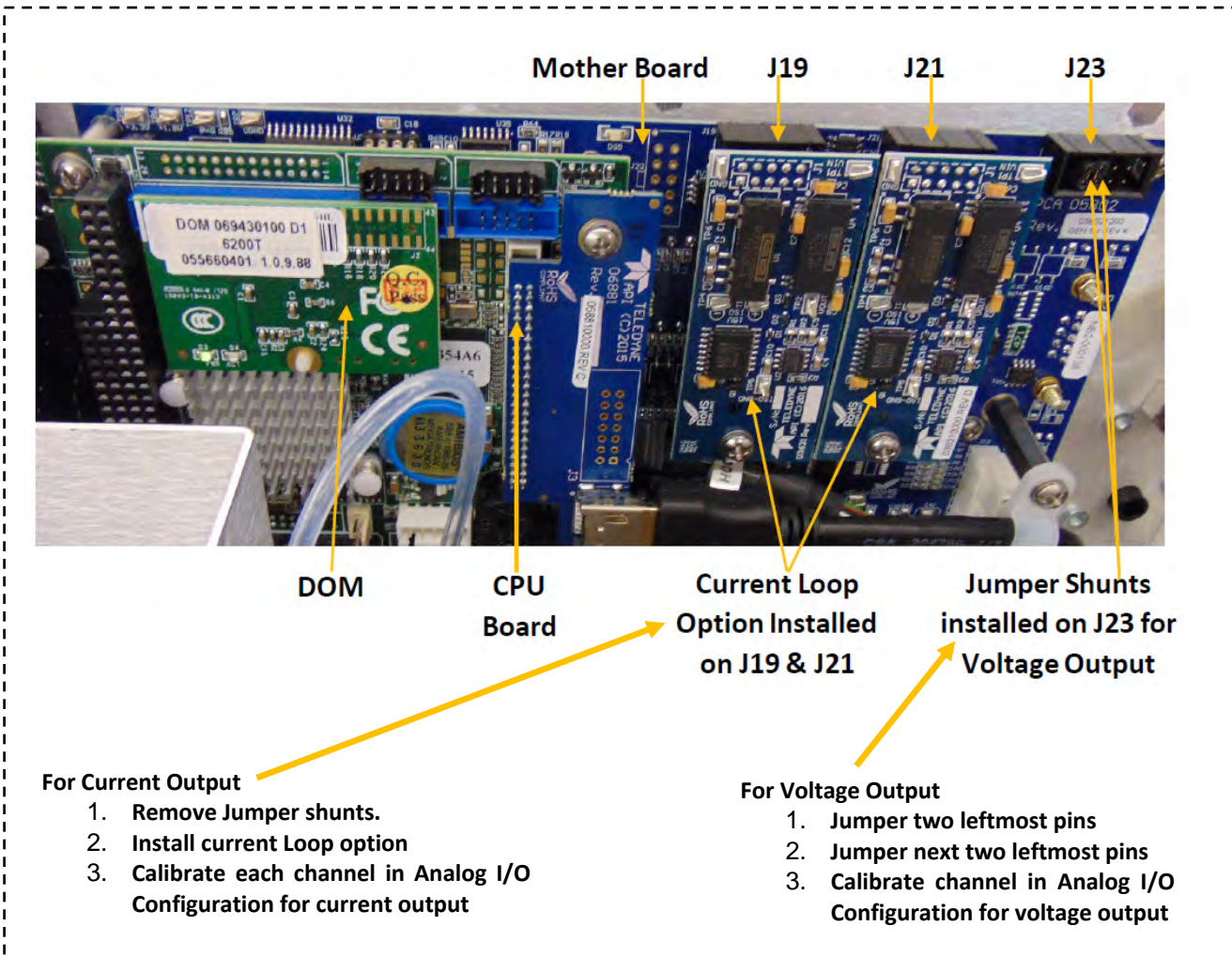

**Figure 3-9: Current Loop Option Installed on the Motherboard**

### 3.3.1.4. Connecting the Status Outputs

The status outputs report analyzer conditions via optically isolated NPN transistors, which sink up to 50 mA of DC current. These outputs can interface with devices that accept logic-level digital inputs, such as Programmable Logic Controllers (PLCs). Each status bit is an open collector output that can withstand up to 40 VDC. All of the emitters of these transistors are tied together and available at the “D” connector pin.

#### ATTENTION

#### COULD DAMAGE INSTRUMENT AND VOID WARRANTY

Most PLC's have internal provisions for limiting the current that the input will draw from an external device. When connecting to a unit that does not have this feature, an external dropping resistor must be used to limit the current through the transistor output to less than 50 mA. At 50 mA, the transistor will drop approximately 1.2V from its collector to emitter.

The status outputs are accessed via a 12-pin connector on the analyzer's rear panel labeled STATUS (Figure 3-). Pin-outs for this connector are presented in Table 3-7.

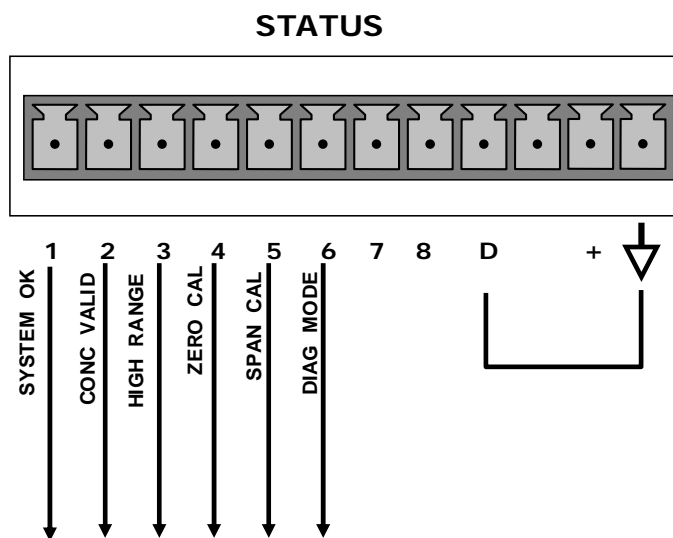



Figure 3-10: Status Output Connector



Table 3-7: Status Output Signals

REAR PANEL LABEL	STATUS DEFINITION	CONDITION
1	SYSTEM OK	ON if no faults are present.
2	CONC VALID	OFF any time the <b>HOLD OFF</b> feature is active, such as during calibration or when other faults exist possibly invalidating the current concentration measurement (example: sample flow rate is outside of acceptable limits). ON if concentration measurement is valid.
3	HIGH RANGE	ON if unit is in high range of either the DUAL or Auto range modes.
4	ZERO CAL	ON whenever the instrument's <b>ZERO</b> point is being calibrated.
5	SPAN CAL	ON whenever the instrument's <b>SPAN</b> point is being calibrated.
6	DIAG MODE	ON whenever the instrument is in <b>DIAGNOSTIC</b> mode
7&8	SPARE	
D	EMITTER BUS	The emitters of the transistors on pins 1-8 are bussed together.
	SPARE	
+	DC POWER	+ 5 VDC, 300 mA source (combined rating with Control Output, if used).
	Digital Ground	The ground level from the analyzer's internal DC power supplies

### 3.3.1.5. Connecting the Control Inputs

If you wish to use the analyzer to remotely activate the zero and span calibration modes, several digital control inputs are provided through a 10-pin connector labeled **CONTROL IN** on the analyzer's rear panel.

There are two methods for energizing the control inputs. The internal +5V available from the pin labeled "+" is the most convenient method. However, if full isolation is required, an external 5 VDC power supply should be used.

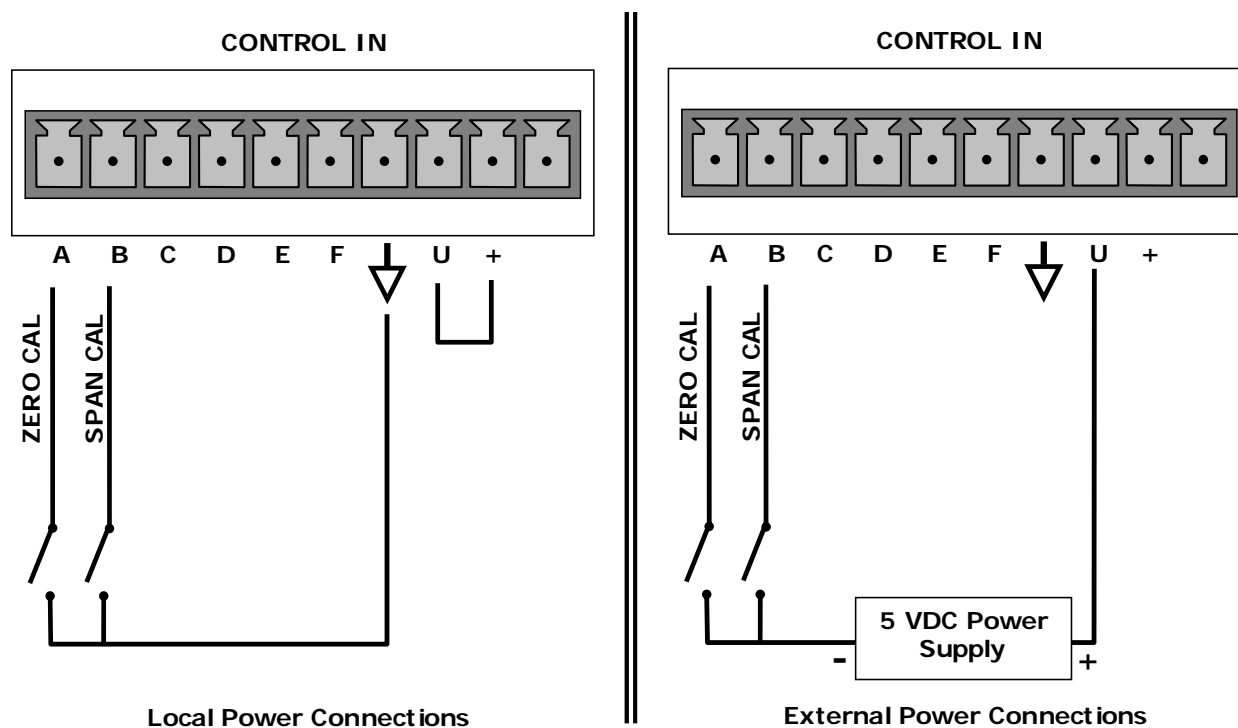

Figure 3-11: Control Input Connector

Table 3-8: Control Input Signals

Input #	Status Definition	ON Condition
A	<b>REMOTE ZERO CAL</b>	The analyzer is placed in Zero Calibration mode. The mode field of the display will read <b>ZERO CAL R.</b>
B	<b>REMOTE SPAN CAL</b>	The analyzer is placed in span calibration mode as part of performing a low span (midpoint) calibration. The mode field of the display will read <b>LO CAL R.</b>
C, D, E & F	SPARE	
⏚	Digital Ground	The ground level from the analyzer's internal DC power supplies (same as chassis ground)
U	External Power input	Input pin for +5 VDC is required to activate pins A – F.
+	5 VDC output	Internally generated 5V DC power. To activate inputs A – F, place a jumper between this pin and the "U" pin. The maximum amperage through this port is 300 mA (combined with the analog output supply, if used).



### 3.3.1.6. Connecting the Concentration Alarm Relay

The concentration alarm option is comprised of four (4) “dry contact” relays on the rear panel of the instrument. Each relay has 3 pins: Normally Open (NO), Common (C) and Normally Closed (NC).

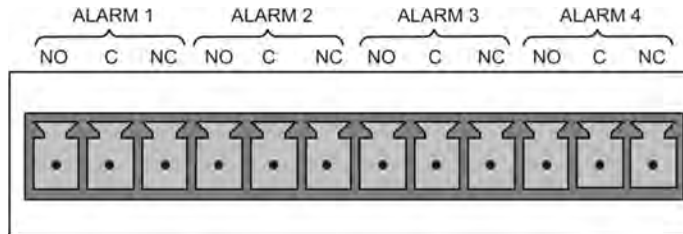

Figure 3-6: Concentration Alarm Relay

**Alarm 1** “System OK 2”

**Alarm 2** “Conc 1”

**Alarm 3** “Conc 2”

**Alarm 4** “No function.”

#### “Alarm 1” Relay

Alarm 1 is the “System OK2” alarm. It is energized when there are no warnings active. If there is an active warning or the instrument is placed in the “DIAG” mode, Alarm 1 will change state. Alarm 1 has been configured at the factory as “failsafe” where the relay is energized when the instrument is OK. If power is shut off or lost, the relay is de-energized.

#### “Alarm 2” Relay & “Alarm 3” Relay

Alarm 2 relay is associated with the “Concentration Alarm 1” set point in the software; Alarm 3 relay is associated with the “Concentration Alarm 2” set point in the software.

**Alarm 2 Relay**            **TS Alarm 1 = xxx PPM**

**Alarm 3 Relay**            **TS Alarm 2 = xxx PPM**

**Alarm 2 Relay**            **TS Alarm 1 = xxx PPM**

**Alarm 3 Relay**            **TS Alarm 2 = xxx PPM**

Alarm 2 relay will be turned on any time the concentration value exceeds the set-point, and will return to its normal state when the concentration value returns below the concentration set-point.

Even though the relay on the rear panel is a NON-Latching alarm and resets when the concentration goes back below the alarm set point, the warning on the front panel of the instrument will remain latched until it is cleared. You can clear the warning on the front panel either manually by pressing the CLR button on the front panel touch-screen or remotely through the serial port.

#### “Alarm 4” Relay

On this instrument, this relay has no function.

### 3.3.1.7. Connecting the Communications Interfaces

The T-Series analyzers are equipped with connectors for remote communications interfaces: **Ethernet**, **USB**, **RS-232**. In addition to using the appropriate cables, each type of communication method, must be configured using the SETUP>COMM menu, Section 5.9.9. Although Ethernet is DHCP-enabled by default, it can also be configured manually (Section 6.4.1) to set up a static IP address.

### Ethernet Connection

For network or Internet communication with the analyzer, connect an Ethernet cable from the analyzer's rear panel Ethernet interface connector to an Ethernet port. Please refer to Section 6.4 for a description of the default configuration and setup instructions.

### RS-232 Connection

For **RS-232** communications with data terminal equipment (**DTE**) or with data communication equipment (**DCE**) connect either a DB9-female-to-DB9-female cable (Teledyne Analytical Instruments part number WR000077) or a DB9-female-to-DB25-male cable as applicable, from the analyzer's rear panel RS-232 port to the device. Adjust the DCE-DTE switch (Figure 3-4) to select DTE or DCE as appropriate.

**Configuration:** Sections 5.7 and 6.3

#### IMPORTANT

#### IMPACT ON READINGS OR DATA

Cables that appear to be compatible because of matching connectors may incorporate internal wiring that makes the link inoperable. Check cables acquired from sources other than Teledyne Analytical Instruments for pin assignments (Figure 3-7) before using.

### RS-232 COM Port Connector Pin-outs

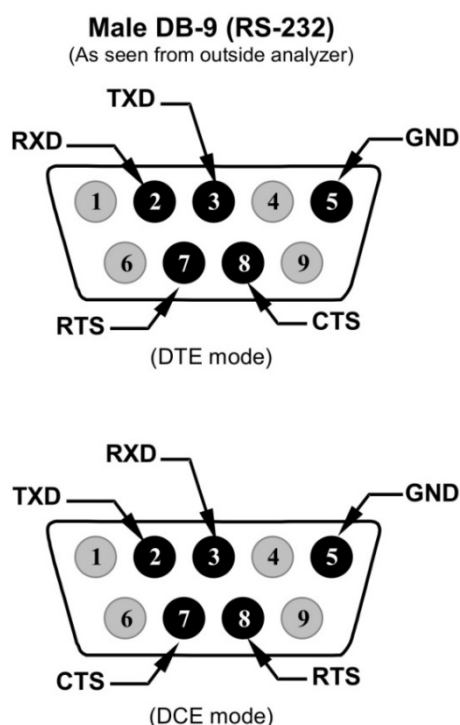

**Figure 3-7: Rear Panel Connector Pin-Outs for RS-232 Mode**

The signals from these two connectors are routed from the motherboard via a wiring harness to two 10-pin connectors on the CPU card, J11 and J12 (Figure 3-8).



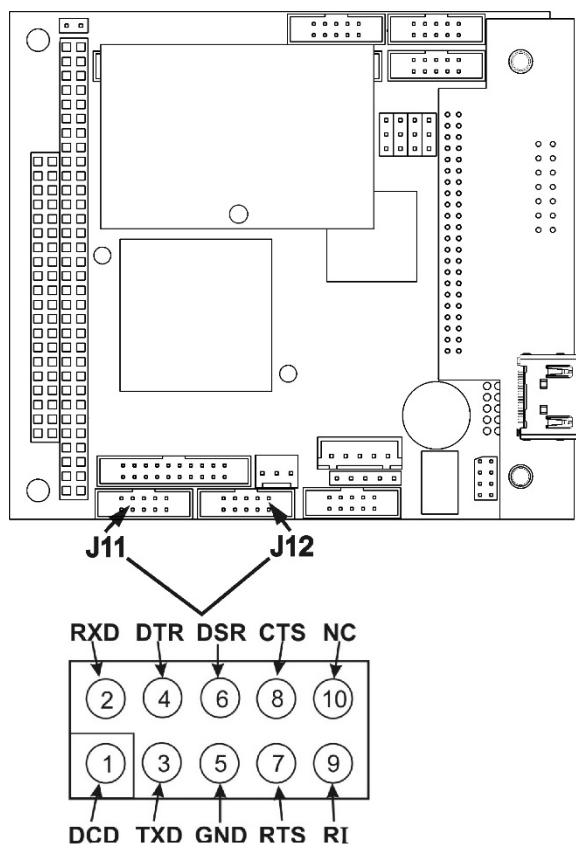

**Figure 3-8: CPU Connector Pin-Outs for RS-232 Mode**

### RS-232 COMM Port Default Settings

As received from the factory, the analyzer is set up to emulate a DCE (Section 6.1) or modem, with Pin 3 of the DB-9 connector designated for receiving data and Pin 2 designated for sending data.

#### **RS-232:** RS-232 (fixed) DB-9 male connector

- Baud rate: 9600 bits per second (baud)
- Data Bits: 8 data bits with 1 stop bit
- Parity: None

#### **COM2:** RS-232 (configurable to RS 485), DB-9 female connector.

- Baud rate: 19200 bits per second (baud).
- Data Bits: 8 data bits with 1 stop bit.
- Parity: None.

**Configuration:** Section 6.3

### 3.3.2. Pneumatic Connections

This section provides not only pneumatic connection information, but also important information about the gases required for accurate calibration (Section 3.3.2.6); it also illustrates the pneumatic layouts for the analyzer in three common configurations.

Before making the pneumatic connections, carefully note the following cautionary and additional messages:



**CAUTION**  
**GENERAL SAFETY HAZARD**  
**SULFUR DIOXIDE (SO<sub>2</sub>) IS A TOXIC GAS.**

**DO NOT vent calibration gas and sample gas into enclosed areas. Obtain a Material Safety Data Sheet (MSDS) for this material. Read and rigorously follow the safety guidelines described there.**



**CAUTION**  
**GENERAL SAFETY HAZARD**

**Sample and calibration gases should only come into contact with PTFE (Teflon) or glass tubes and fixtures.**

**They SHOULD NOT come in contact with brass or stainless steel fittings prior to the reaction cell.**

**The exhaust from the analyzer's internal pump MUST be vented outside the immediate area or shelter surrounding the instrument.**

**It is important to conform to all safety requirements regarding exposure to SO<sub>2</sub>.**





---

**COULD DAMAGE INSTRUMENT AND VOID WARRANTY****Maximum Pressure:**

Ideally the maximum pressure of any gas at the sample inlet should equal ambient atmospheric pressure and should NEVER exceed 1.5 in-hg above ambient pressure.

**Venting Pressurized Gas:****ATTENTION**

In applications where any gas (span gas, zero air supply, sample gas is) received from a pressurized manifold, a vent must be provided to equalize the gas with ambient atmospheric pressure before it enters the analyzer to ensure that the gases input do not exceed the maximum inlet pressure of the analyzer, as well as to prevent back diffusion and pressure effects. These vents should be:

- at least 0.2m long no more than 2m long
- vented outside the shelter or immediate area surrounding the instrument.

**Dust Plugs:**

Remove dust plugs from rear panel exhaust and supply line fittings before powering on/operating instrument. These plugs should be kept for reuse in the event of future storage or shipping to prevent debris from entering the pneumatics.

---

**IMPORTANT****EPA Requirements:**

US EPA requirements state that zero air and span gases must be supplied at twice the instrument's specified gas flow rate. Therefore, the 6200T zero and span gases should be supplied to their respective inlets in excess of 1300 cc<sup>3</sup>/min (650 cc<sup>3</sup>/min. x 2).

---

**IMPORTANT****Leak Check:**

Run a leak check once the appropriate pneumatic connections have been made; check all pneumatic fittings for leaks using the procedures defined in Section 9.3.6.

---

**CAUTION – GENERAL SAFETY HAZARD**

**Gas flow through the analyzer must be maintained at all time for units with a permeation tube installed. Insufficient gas flow allows gas to build up to levels that will contaminate the instrument or present a safety hazard to personnel.**

One primary application of this instrument is to analyze CO<sub>2</sub> sample gas for sulfur containing impurities. Typically the impurities should be at low levels; therefore it is especially important that the zero calibration of the analyzer is done accurately so that even small levels of impurities can be detected.

**CO<sub>2</sub> Source**

For this type of application, a source of CO<sub>2</sub> that is free of sulfides is required for accurate zero calibration of the instrument. If the 'zero gas' used to zero the instrument is contaminated, the process gas will read artificially low, sometimes even showing a negative TS concentration. Standard CO<sub>2</sub> bottles can have unacceptably high levels of sulfur compounds in them. Beverage grade CO<sub>2</sub> should be used as a diluent as well as the 'zero gas' source for calibration of the 6200T.

Since CO<sub>2</sub> strongly quenches the SO<sub>2</sub> fluorescence reaction, the instrument sensitivity will be greatly reduced when using CO<sub>2</sub> as the balance gas. Therefore it is imperative that the 6200T be calibrated using CO<sub>2</sub> as the balance gas when it will be measuring TS in a gas matrix that is primarily CO<sub>2</sub>.

CO<sub>2</sub> liquefies when compressed, and sulfur compounds do not stay dissolved in liquid CO<sub>2</sub>. Therefore it is not practical to use compressed gas bottles of H<sub>2</sub>S in CO<sub>2</sub> for span calibration purposes. TAI strongly recommends that H<sub>2</sub>S in N<sub>2</sub> bottles be used for span calibration of the 6200T, and that a calibrator be used to mix zero gas (CO<sub>2</sub>) into the span cal gas stream, making the final calibration gas mostly CO<sub>2</sub>.



### 3.3.2.1. Pneumatic Layout for Standard Configuration

Figure 3- shows the internal, pneumatic connections for a standard 6200T.

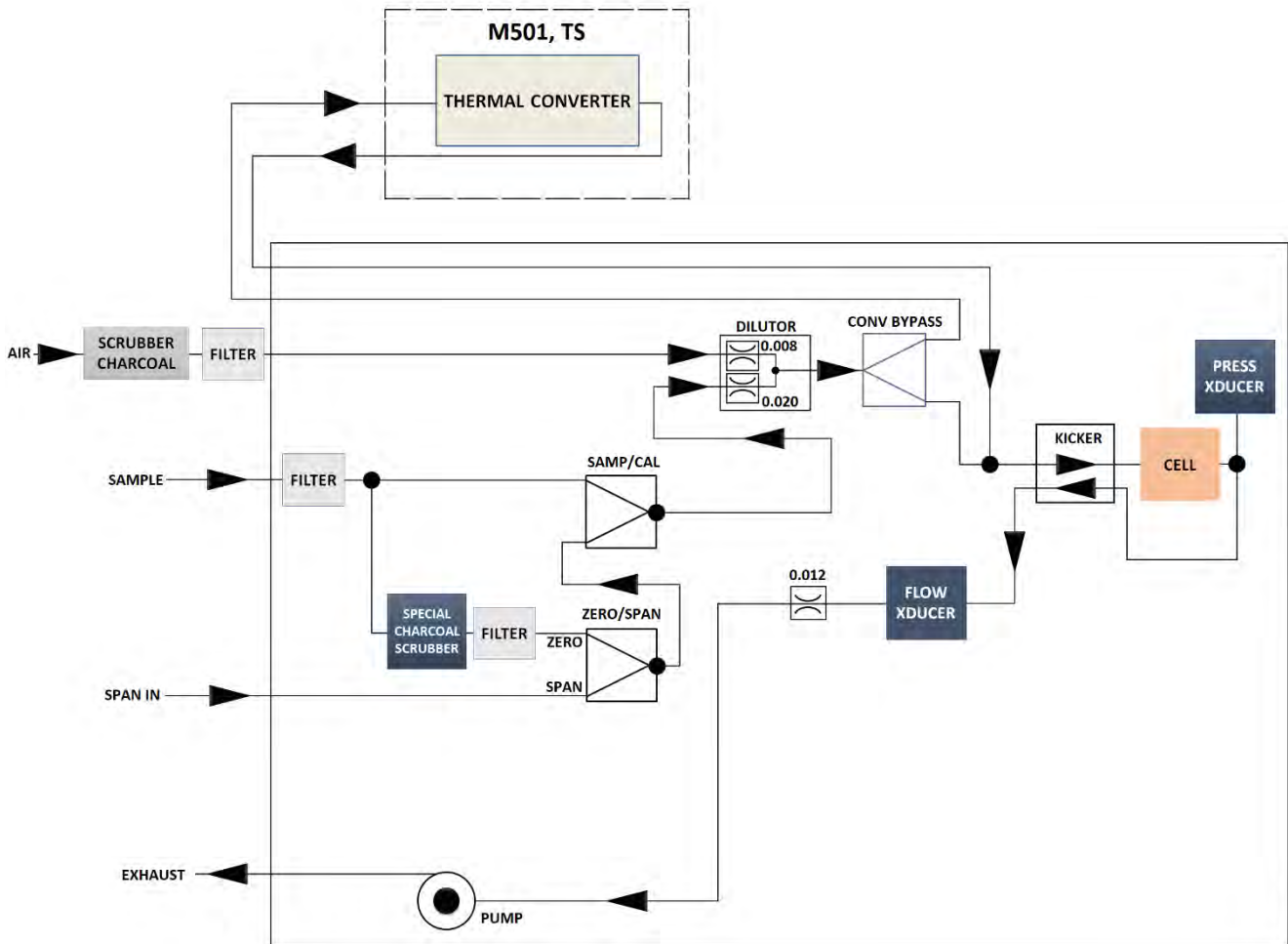

Figure 3-15: 6200T, Standard Unit Pneumatic Layout

Table 3-9 describes the state of each valve during the analyzer’s various operational modes.

Table 3-9: Zero/Span and Sample/Cal Valve Operating States

MODE	VALVE	CONDITION
SAMPLE	Sample/Cal	Open to SAMPLE inlet
	Zero/Span	Open to ZERO AIR inlet
ZERO CAL	Sample/Cal	Open to zero/span inlet
	Zero/Span	Open to ZERO inlet to allow Sample through special TS Scrubber
SPAN CAL	Sample/Cal	Open to zero/span inlet
	Zero/Span	Open to SPAN GAS inlet

The state of the zero/span valves can also be controlled by any of the following means:

- Manually from the analyzer’s front panel by using the **SIGNAL I/O** controls located within the **DIAG** Menu (refer to Section 5.9.1)

- By activating the instrument's AutoCal feature (refer to Section 8.7)
- Remotely by using the external digital control inputs (refer to Section 8.1.2 and Section 8.6.1)
- Remotely through the RS-232/485 serial I/O ports (refer to Appendix A-6 for the appropriate commands)

Sources of zero and span gas must be capable of supplying at least 1.55 L/min. (maximum 2.5L/min). Both supply lines should be vented outside of the analyzer's enclosure. In order to prevent back-diffusion and pressure effects, these vent lines should be between 2 and 10 meters in length.

### 3.3.2.2. Pneumatic Layout for Built-in H<sub>2</sub>S Permeation Device Option

Figure 3- shows the internal, pneumatic connections for the analyzer with the IZS option installed.

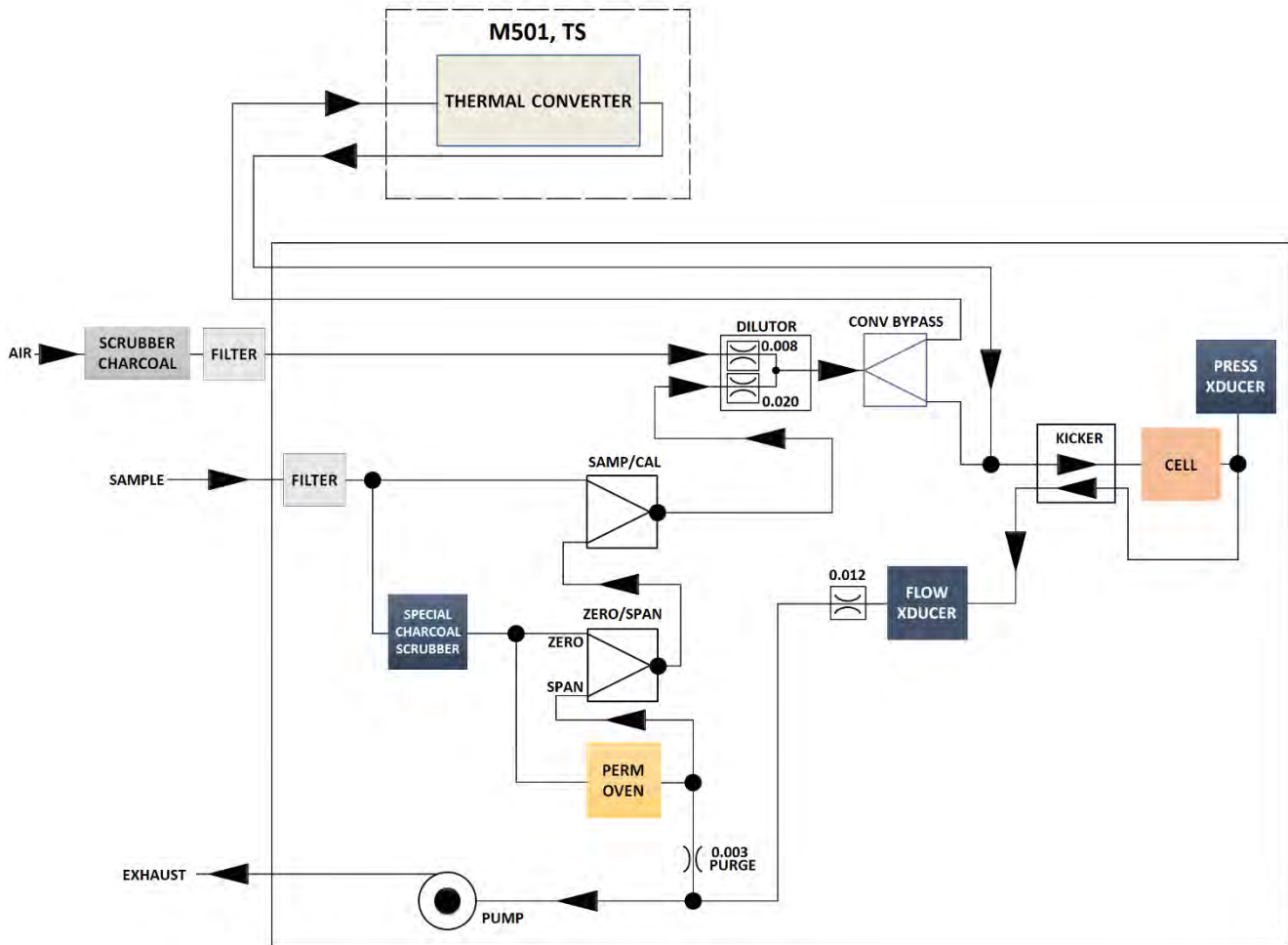

**Figure 3-16: Pneumatic Layout with H<sub>2</sub>S Permeation Device Options**

The internal zero air and span gas generator (IZS) option includes a heated enclosure (Section 3.3.2.3) for a permeation tube (permeation tube must be purchased separately), an external scrubber (Section 3.3.2.5) for producing zero air and a set of valves for switching between the sample gas inlet and the output of the zero/span subsystem, functionally very similar to the valves included in the zero/span valve option.

Table 3-10 describes the operational state of the valves associated with the IZS option during the analyzer's various operating modes.



Table 3-10: IZS Valve Operating States

MODE	VALVE	CONDITION
SAMPLE	Sample/Cal	Open to SAMPLE inlet
	Zero/Span	Open to ZERO AIR inlet
ZERO CAL	Sample/Cal	Open to zero/span valve
	Zero/Span	Open to ZERO inlet to allow Sample through special TS Scrubber
SPAN CAL	Sample/Cal	Open to zero/span valve
	Zero/Span	Open to SPAN GAS inlet to allow Sample gas through to H <sub>2</sub> S Permeation Device Via special TS Scrubber

The state of the IZS valves can also be controlled by any of the following means:

- Manually from the analyzer's front panel by using the **SIGNAL I/O** controls under the **DIAG** Menu (refer to Section 5.9.1),
- By activating the instrument's AutoCal feature (refer to Section 8.7),
- Remotely by using the external digital control inputs (refer to Section 8.1.2 and Section 8.6.1),
- Remotely through the RS-232/485 serial I/O ports.

**Note**

**The permeation tube is not included in the IZS Option and must be ordered separately**

**3.3.2.3. Permeation Tube Heater**

In order to keep the permeation rate constant, the IZS enclosure is heated to a constant 50° C (10° above the maximum operating temperature of the instrument). The IZS heater is controlled by a precise PID (Proportional/Integral/Derivative) temperature control loop. A thermistor measures the actual temperature and reports it to the CPU for control feedback.

**3.3.2.4. Span Gas Concentration Variation**

Span gas is created when zero gas passes over a permeation tube containing liquid H<sub>2</sub>S under high pressure, which slowly permeates through a PTFE membrane into the surrounding air. The speed at which the H<sub>2</sub>S permeates the membrane is called the effusion rate. The concentration of the span gas is determined by three factors:

- Size of the membrane: The larger the area of the membrane, the more permeation occurs.
- Temperature of the H<sub>2</sub>S: Increasing the temperature of the increases the pressure inside the tube and therefore increases the effusion rate.
- Flow rate of the CO<sub>2</sub> zero gas: If the previous two variables are constant, the permeation rate of CO<sub>2</sub> into the zero gas stream will be constant. Therefore, a lower flow rate of zero gas produces higher concentrations of H<sub>2</sub>S. The 6200T usually has a constant flow rate and a constant permeation rate; hence, variations in concentration can be achieved by changing the IZS temperature.

### 3.3.2.5. TS and Zero Air Scrubbers

There are two charcoal scrubbers in the analyzer chassis of the 6200T. The scrubber canister on the outside of the rear panel of the analyzer is a standard charcoal scrubber that supplies zero air for the diluter assembly. The second scrubber is located inside the analyzer behind the sample pump. This scrubber uses a specially impregnated charcoal (TAI Part# CH\_52) which is especially effective in scrubbing TS gasses. This filter is used to scrub TS from the inlet sample gas for use in zero calibrating the analyzer.

### 3.3.2.6. About Zero Gas and Calibration (Span) Gases

Zero Gas and Span Gas are required for accurate calibration.

There are two charcoal scrubbers in the analyzer chassis of the 6200T. The scrubber canister on the outside of the rear panel of the analyzer is a standard charcoal scrubber that supplies zero air for the diluter assembly. The second scrubber is located inside the analyzer behind the sample filter. This scrubber uses a specially impregnated charcoal (TAI Part# CH\_52) which is especially effective in scrubbing TS gases. This filter is used to scrub TS from the inlet sample gas for use in zero calibrating the analyzer.

#### Zero Gas

Zero Calibration of Model 6200T, Total sulphide analyzer performed with sample gas flowing through special charcoal scrubber installed in analyzer, which removes the sulphide components in the sample gas & only background gas, which is zero gas to the analyzer. In case no CO<sub>2</sub> sample gas available, use TS free UHP grade CO<sub>2</sub> gas as zero gas.

#### Calibration (Span) Gas

The most common application of this instrument is to analyze CO<sub>2</sub> sample gas for sulfur containing impurities. Typically the impurities should be at low levels; therefore it is especially important that the zero calibration of the analyzer is done accurately so that even small levels of impurities can be detected.

In these types of applications, a source of CO<sub>2</sub> that is free of sulfides is required for accurate zero calibration of the instrument. If the 'zero gas' used to zero the instrument is contaminated, the process gas will read artificially low, sometimes even showing a negative TS concentration. Standard CO<sub>2</sub> bottles can have unacceptably high levels of sulfur compounds in them. Beverage grade CO<sub>2</sub> should be used as a diluent as well as the 'zero gas' source for calibration of the 6200T.

Since CO<sub>2</sub> strongly quenches the SO<sub>2</sub> fluorescence reaction, the instrument sensitivity will be greatly reduced when using CO<sub>2</sub> as the balance gas. Therefore it is imperative that the 6200T be calibrated using CO<sub>2</sub> as the balance gas when it will be measuring TS in a gas matrix that is primarily CO<sub>2</sub>.

CO<sub>2</sub> liquefies when compressed, and sulfur compounds do not stay dissolved in liquid CO<sub>2</sub>. Therefore it is not practical to use compressed gas bottles of H<sub>2</sub>S in CO<sub>2</sub> for calibration purposes. TAI strongly recommends that H<sub>2</sub>S in N<sub>2</sub> bottles be used for calibration of the 6200T, and that a calibrator be used to mix zero gas (CO<sub>2</sub>) into the cal gas stream, making the final calibration gas mostly CO<sub>2</sub>. **Refer Figure 1.3: Model 6200T with PRC6000, Precision Calibrator setup.**



For other applications not involving CO<sub>2</sub>, TAI recommends a calibration gas specifically mixed to match the chemical composition of the type of gas being measured at near full scale of the desired measurement range. In this case, TS measurements made with the Teledyne Analytical Instruments 6200T UV Fluorescence SO<sub>2</sub> Analyzer, it is recommended that you use a span gas with a H<sub>2</sub>S OR COS concentration equal to 80% of the measurement range for your application. Span gas must be selected as per process gas sulfur components.

EXAMPLE: If the application having H<sub>2</sub>S as major sulfur component in CO<sub>2</sub> sample gas, to measure TS between 0 ppm and 500 ppb, an appropriate span gas concentration would be 450 ppb H<sub>2</sub>S in CO<sub>2</sub>. If the application having COS as major sulfur component in CO<sub>2</sub> sample gas, to measure TS between 0 ppm and 500 ppb, an appropriate span gas concentration would be 450 ppb COS in CO<sub>2</sub>.

### 3.4. Startup, Functional Checks, and Initial Calibration

If you are unfamiliar with the 6200T principles of operation, we recommend that you read Section 11.



#### CAUTION - GENERAL SAFETY HAZARD

Do not look at the UV lamp while the unit is operating. UV light can cause eye damage. Always use safety glasses made from UV blocking material whenever working with the UV Lamp. (Generic plastic glasses are not adequate).

#### 3.4.1. Startup

After the electrical and pneumatic connections are made, an initial functional check is in order. Turn on the instrument. The pump and exhaust fan should start immediately. The display will show a momentary splash screen of the Teledyne Analytical Instruments logo and other information during the initialization process while the CPU loads the operating system, the firmware and the configuration data.

The analyzer should automatically switch to Sample Mode after completing the boot-up sequence and start monitoring the gas. However, there is an approximately one hour warm-up period before reliable gas measurements can be taken. During the warm-up period, the front panel display may show messages in the Parameters field.

##### 3.4.1.1. Thermal Converter Startup

The MTS501 Converter uses a temperature controller for setting and controlling the conversion temperature inside the quartz tube. The quartz tube will take 1 to 2 hours to heat up and stabilize at the required temperature. The setpoint and control characteristics have been set up at the factory, but if necessary, they are user adjustable. Refer to the temperature controller manual for making fine adjustments to the temperature setpoint and control characteristics.

#### 3.4.2. Warning Messages

Because internal temperatures and other conditions may be outside the specified limits during the analyzer's warm-up period, the software will suppress most warning conditions for 30 minutes after

power up. If warning messages persist after the 60 minutes warm up period is over, investigate their cause using the troubleshooting guidelines in Section 10.1.1.

To view and clear warning messages, press:

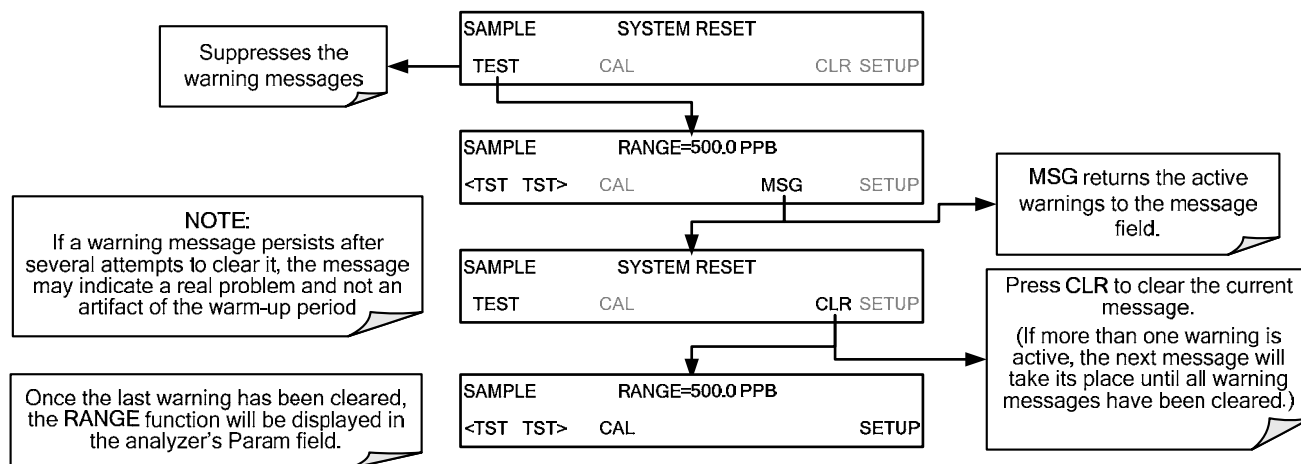

**Figure 3-17: Warning Messages**

Table 3-11 lists brief descriptions of the warning messages that may occur during start up for 6200T analyzers with no options installed.

**Table 3-11: Possible Startup Warning Messages – 6200T Analyzers w/o Options**

Message	Meaning
<b>ANALOG CAL WARNING</b>	The instrument's A/D circuitry or one of its analog outputs is not calibrated.
<b>BOX TEMP WARNING</b>	The temperature inside the 6200T chassis is outside the specified limits.
<b>CANNOT DYN SPAN<sup>2</sup></b>	Remote span calibration failed while the dynamic span feature was set to turned on.
<b>CANNOT DYN ZERO<sup>3</sup></b>	Remote zero calibration failed while the dynamic zero feature was set to turned on.
<b>CONFIG INITIALIZED</b>	Configuration was reset to factory defaults or was erased.
<b>DARK CAL WARNING</b>	Dark offset above limit specified indicating that too much stray light is present in the sample chamber.
<b>DATA INITIALIZED</b>	DAS data storage was erased.
<b>HVPS WARNING</b>	High voltage power supply for the PMT is outside of specified limits.
<b>PMT DET WARNING</b>	PMT detector output is outside of operational limits.
<b>PMT TEMP WARNING</b>	PMT temperature is outside of specified limits.
<b>RCELL TEMP WARNING</b>	Sample chamber temperature is outside of specified limits.





Message	Meaning
<b>REAR BOARD NOT DET</b>	CPU unable to communicate with motherboard.
<b>RELAY BOARD WARN</b>	CPU is unable to communicate with the relay PCA.
<b>SAMPLE FLOW WARN</b>	The flow rate of the sample gas is outside the specified limits.
<b>SAMPLE PRESS WARN</b>	Sample gas pressure outside of operational parameters.
<b>SYSTEM RESET<sup>1</sup></b>	The computer was rebooted.
<b>UV LAMP WARNING</b>	The UV lamp intensity measured by the reference detector reading too low or too high.
<sup>1</sup> Clears 45 minutes after power up. <sup>2</sup> Clears the next time successful zero calibration is performed. <sup>3</sup> Clears the next time successful span calibration is performed.	
<b>MTS501 Converter Messages</b>	
<b>UUUU</b>	The thermocouple in the converter has failed.

Table 3-12 lists brief descriptions of the warning messages that may occur during start up for 6200T analyzers with optional second gas options or alarms installed.

**Table 3-12: Possible Startup Warning Messages – 6200T Analyzers with Options**

Message	Meaning
<b>O2 CELL TEMP WARN<sup>1</sup></b>	O <sub>2</sub> sensor cell temperature outside of warning limits specified by <i>O2_CELL_SET</i> variable.
<b>IZS TEMP WARNING<sup>2</sup></b>	On units with IZS options installed: The permeation tube temperature is outside of specified limits.
<b>O2 ALARM 1 WARN<sup>1,4</sup></b>	O <sub>2</sub> Alarm limit #1 has been triggered. <sup>4</sup>
<b>O2 ALARM 2 WARN<sup>1,4</sup></b>	O <sub>2</sub> Alarm limit #2 has been triggered. <sup>4</sup>
<b>CO2 ALARM 1 WARN<sup>3,4</sup></b>	CO <sub>2</sub> Alarm limit #1 has been triggered. <sup>4</sup>
<b>CO2 ALARM 2 WARN<sup>3,4</sup></b>	CO <sub>2</sub> Alarm limit #2 has been triggered. <sup>4</sup>
<b>SO2 ALARM1 WARN<sup>4</sup></b>	SO <sub>2</sub> Alarm limit #1 has been triggered. <sup>4</sup>
<b>SO2 ALARM2 WARN<sup>4</sup></b>	SO <sub>2</sub> Alarm limit #2 has been triggered. <sup>4</sup>
<sup>1</sup> Only appears when the optional O <sub>2</sub> sensor is installed. <sup>2</sup> Only appears when the optional internal zero span (IZS) option is installed. <sup>3</sup> Only appears when the optional CO <sub>2</sub> sensor is installed. <sup>4</sup> Only Appears when the optional gas concentration alarms are installed	

### 3.4.3. Functional Checks

After the analyzer's components have warmed up for at least 60 minutes and the temperature inside the quartz tube has stabilized at the setpoint, verify that the software properly supports any hardware options that were installed.

Check to ensure that the analyzer is functioning within allowable operating parameters.

To view the current values of parameters press the following control button sequence on the analyzer's front panel. Remember until the unit has completed its warm up these parameters may not have stabilized.

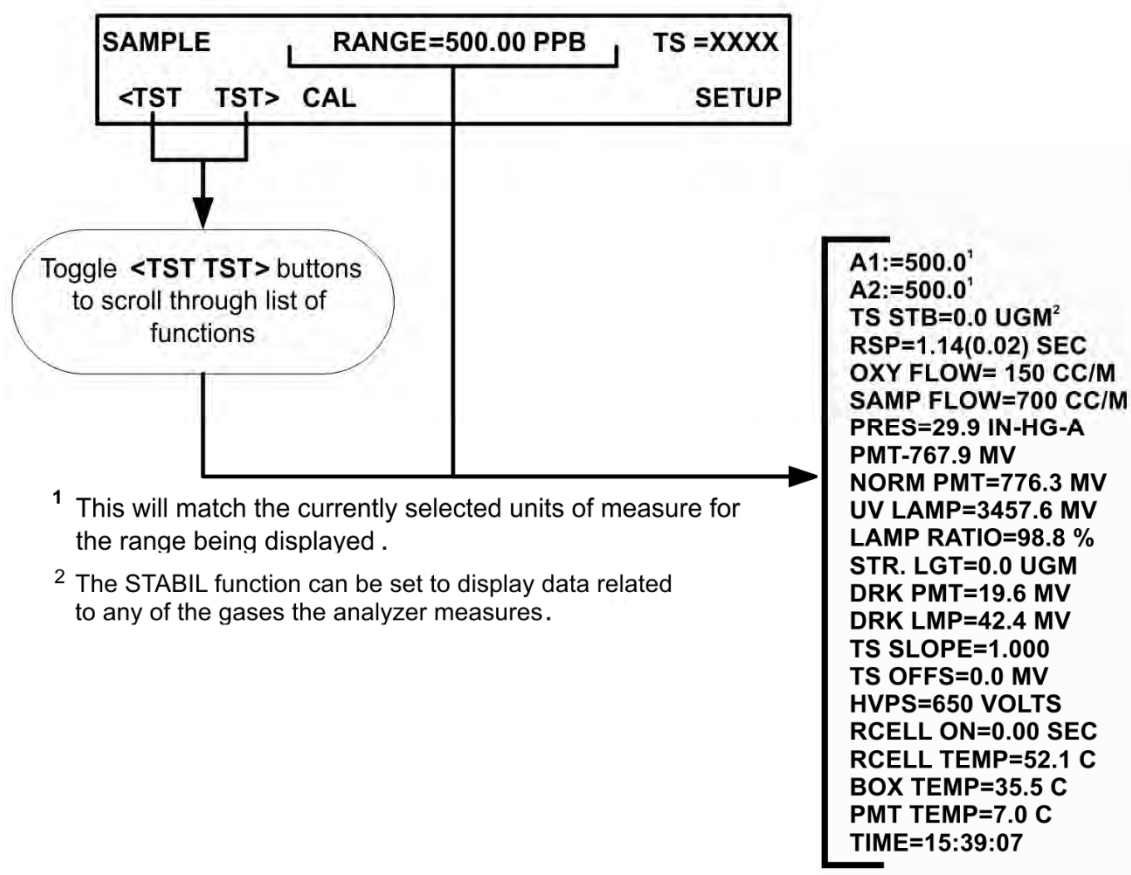

#### Note

The following procedure assumes that gas is introduced through the sample port instead of using zero/span ports provided with Valve Options. Refer to Section Error! Reference source not found. for instructions for calibrating instruments possessing valve options



Note

The 6200T analyzer has been tested for its ability to reject interference for most sources. See Section 11.1.9 for more information on this topic.

Figure 3-9: Functional Check

3.4.4. Initial Calibration

To perform the following calibration you must have sources for zero air and span gas available for input into the sample port on the back of the analyzer. Refer to Section 3.3.2 for instructions for connecting these gas sources.

The initial calibration should be carried out using the same reporting range set up as used during the analyzer’s factory calibration. This will allow you to compare your calibration results to the factory calibration as listed on the *Final Test and Validation Data Sheet*, P/N 04551.

If both available DAS parameters for a specific gas type are being reported via the instruments analog outputs (e.g. **CONC1** and **CONC2** when the **DUAL** range mode is activated), separate calibrations should be carried out for each parameter.

- Use the **LOW** button when calibrating for **CONC1** (equivalent to **RANGE1**).
- Use the **HIGH** button when calibrating for **CONC2** (equivalent to **RANGE2**).

Refer to the Configurable Analog Output Addendum, P/N 06270 for more information on the configurable analog output reporting ranges.

3.4.4.1. Initial Calibration Procedure for Standard Analyzers

The following procedure assumes that cal gas will be supplied through the SAMPLE gas inlet on the back of the analyzer (refer to Figure 3-4), and;

Set TS Span Gas Concentration on Single Range

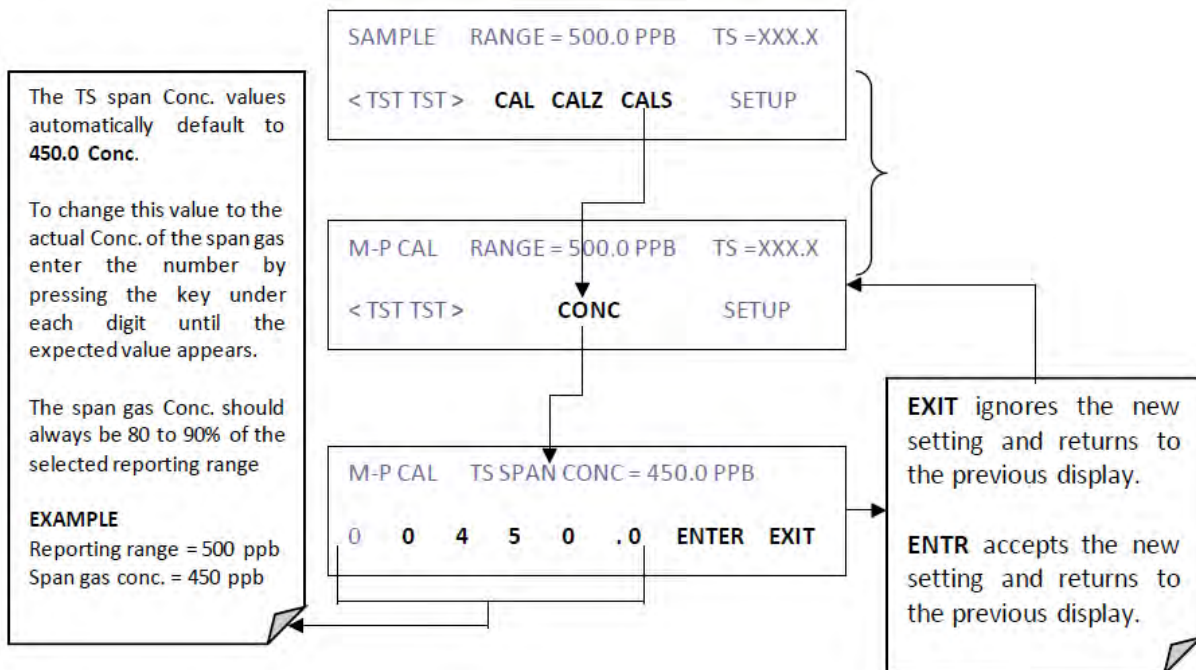

Figure 3-19: TS Span Gas Concentration Settings

Model 6200T standard unit will have Internal Zero and Span valves. Front panel display should display as “CAL CALZ CALS” as shown in above picture. Pressing CALZ, Zero Valve will be activated, and Sample/Zero gas will flow through Special TS Scrubber. When CALS is pressed, Span Valve will be activated, and span will flow. To set Span gas concentration, Press CALS and follow further as per above procedure.

To Set the expected TS span gas concentration & Calibration steps from CAL Option instead of CALS, follow below procedure. This should be 80% to 90% of the concentration range for which the analyzer’s analog output range is set.

From the Main screen, select **CAL**

When unit set for Dual Range, Option as **LOW** & **HIGH** will display during Zero and Span calibration. Select the range to calibrate (**LOW** or **HIGH**) and press **ENTER**. When span gas concentration falls in **LOW** Range, select **LOW** for both Zero and Span gas calibration. When span gas concentration falls in **HIGH** Range, select **HIGH** for both Zero and Span gas calibration. The following screen will appear.

The range limit is shown for the particular range selected and the units displayed above. Note that the **CAL** led is illuminated indicating the instrument is in **CAL** mode. Select **CONC** to view and/or edit the concentration of the span gas you will be using.

The span gas concentration is set to 400 ppb by default, but it can be changed using the **CH>**, **INS>**, **DEL>**, and **[digit]** buttons.

<b>CH&gt;</b>	Selects the digit to edit. The selected digit is enclosed in brackets [ ].
<b>INS&gt;</b>	Inserts a numerical slot to the left of the selected digit.
<b>DEL&gt;</b>	Deletes the numerical slot enclosed in brackets.



<b>[digit]</b>	Increments the value enclosed in brackets. Each press increments the value by 1 and will cycle from 0 to 9 plus (+), minus (-), and then back to 0.
<b>[ENTR]</b>	Saves the value displayed on screen and returns to the previous screen display.
<b>[EXIT]</b>	Ignores the input and reverts to the previous value and returns to the previous screen display.

**Example:** If the currently set span gas concentration value is 400 ppb which would be displayed onscreen as **[4]00.000 Conc** and you want to set the span gas to 1 ppm (1,000 ppb):

1. Use the **INS>** button to add a decimal place to the left of **[4]**.
2. Press **[0]** once to increment it to **[1]**.
3. Press **CH>** to move the bracket to **[4]**.
4. Press **[4]** repeatedly until the displayed number returns to **[0]**.
5. Press **ENTR** to save the new span gas concentration (1,000 ppb).

### Perform Quick Leak Test on Model 6200T/501TS

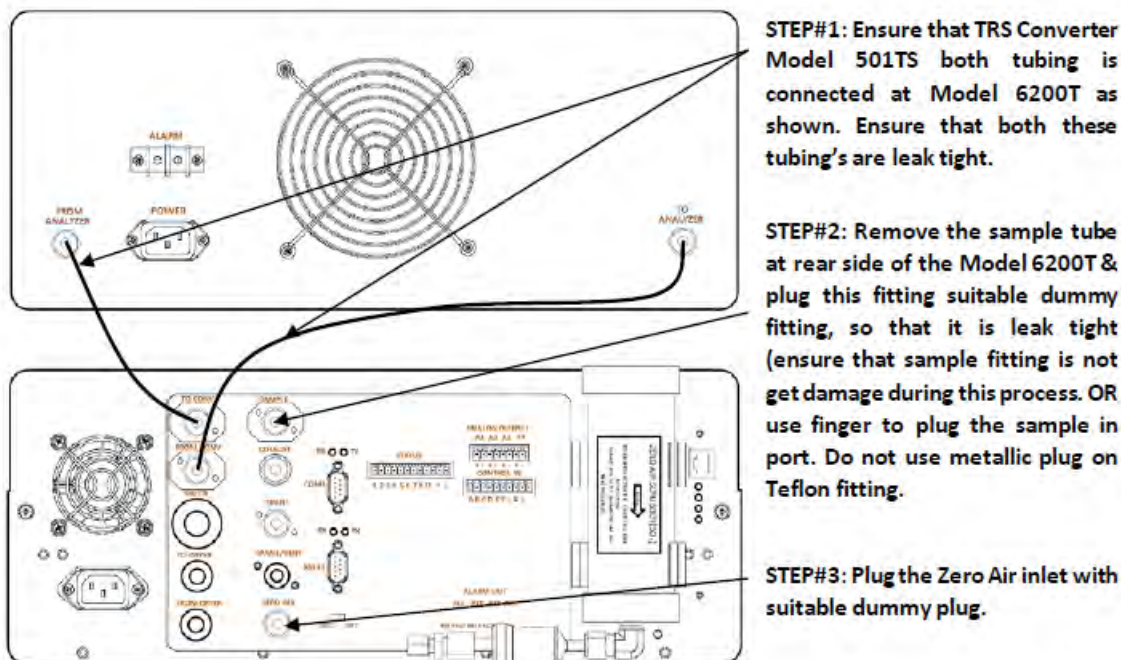

Once the above three steps are performed properly, monitor the Sample Pressure, Sample Flow & Air Flow on the front panel of 6200T

SAMPLE SAMPL FL = 523ccm TS =XXX.X

< TST TST > CAL CALZ CALS SETUP

SAMPLE PRES = 24.2" HG-A TS =XXX.X

< TST TST > CAL CALZ CALS SETUP

SAMPLE OXY FL = 140ccm TS =XXX.X

< TST TST > CAL CALZ CALS SETUP

Scroll the <TST TST> button on front panel & monitor the SAMPL FLOW, PRESS & OXY FL.

Wait for couple of minutes to stabilize the readings on display. It will take approx. 5 to 10 minutes.

**Please note:**  
Sample Press should go below 10" HG-A. Sample flow & Oxygen flow should go below 10cc/min. if yes, then system is leak tight. If not, then there is some leak, inside or outside the unit. Arrest the leak & then proceed for Zero & span calibration of the unit.

**Pneumatic Setup for Zero/Span Gas Calibration & Sampling for Standard Units**



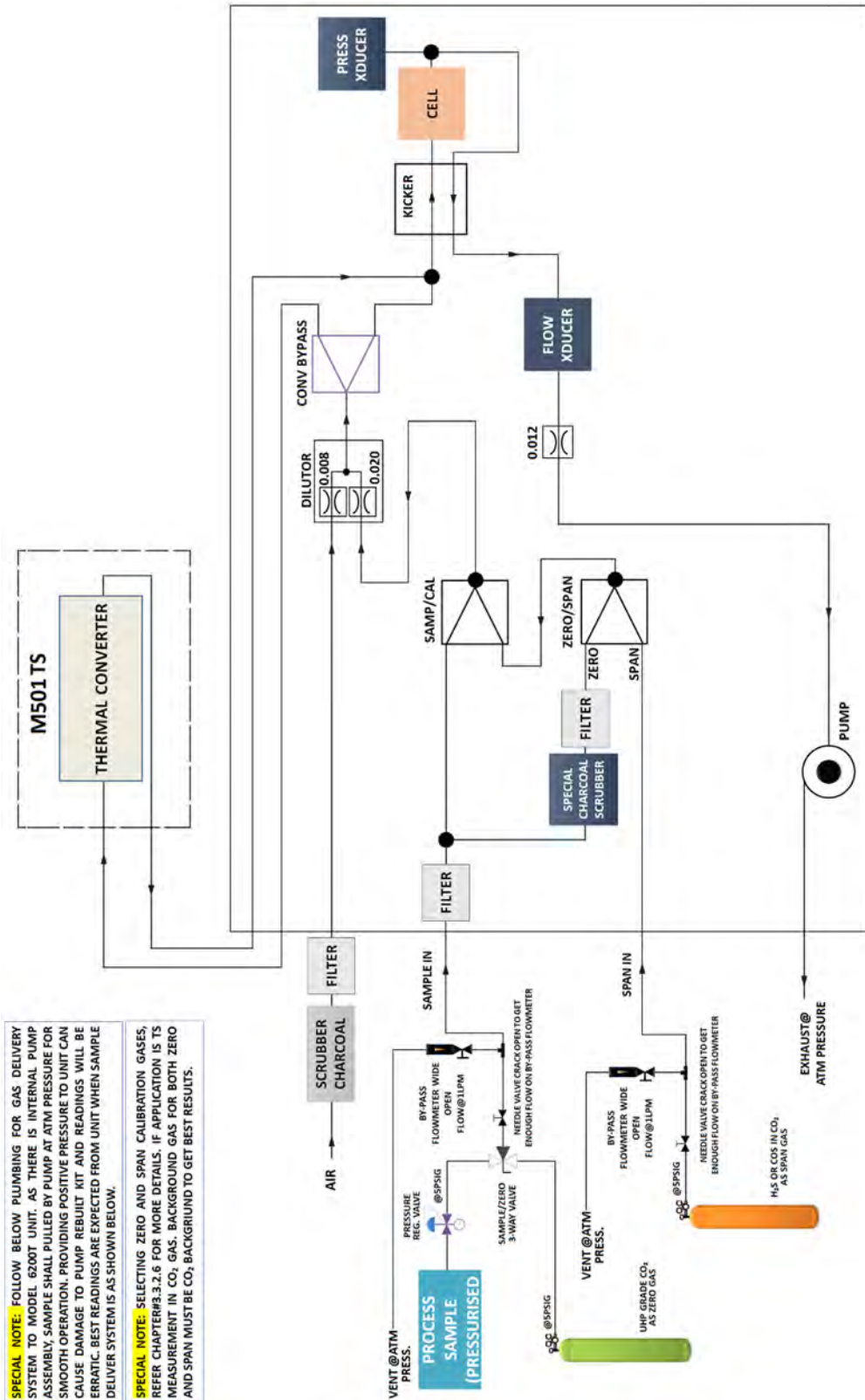

Figure 3-2010: 6200T, Standard Pneumatic SetUp for Calibration & Sampling

Pneumatic Setup for Zero/Span Gas Calibration & Sampling for Standard Units with PRC6000/702, Precision Calibrator

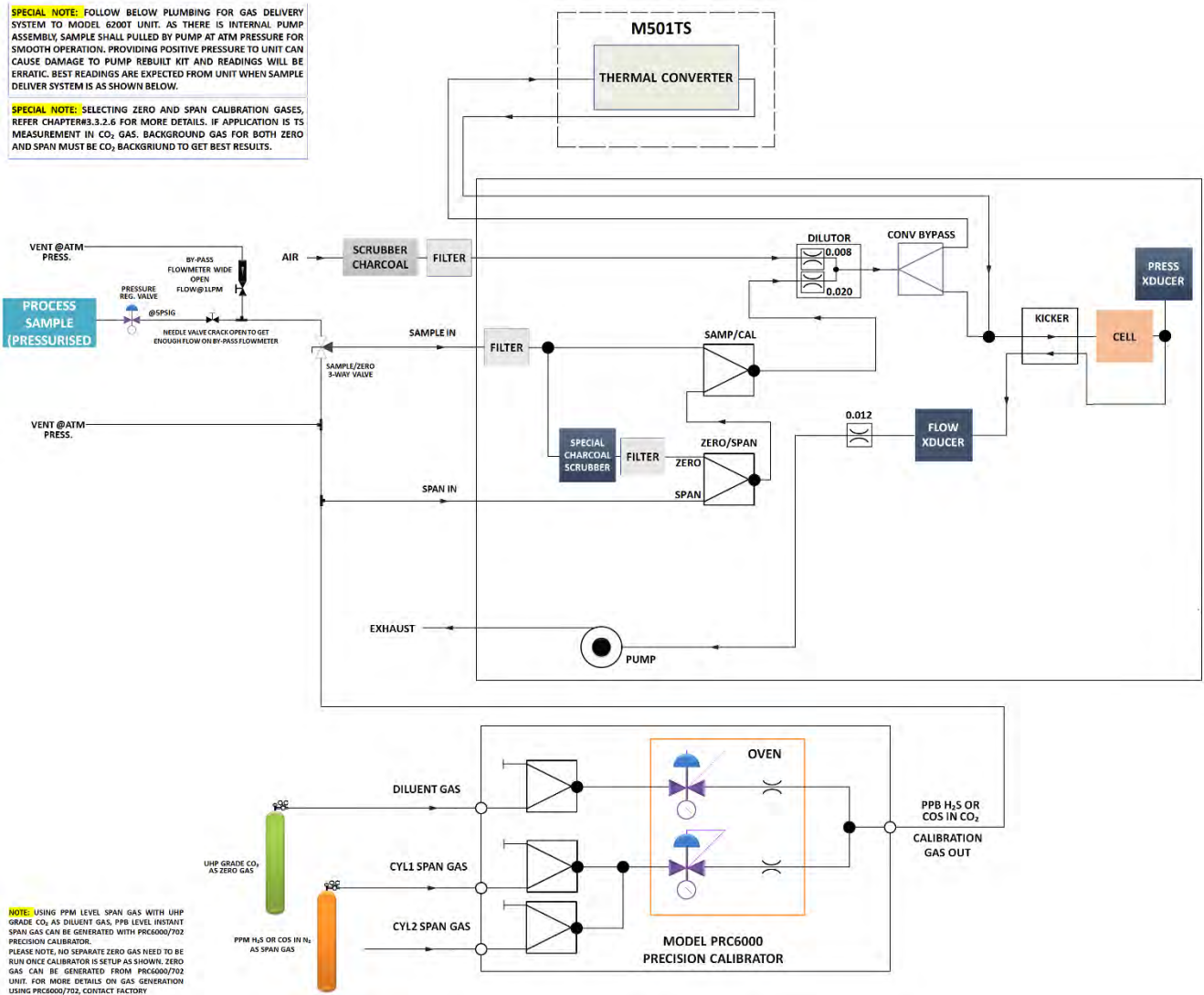

Figure 3-2111: 6200T with PRC6000/702, Pneumatic Setup for Calibration & Sampling

Please note, Calibration steps will be same for both standard 6200T unit with or without PRC6000/702, Precision Calibrator.





**Zero Calibration Procedure**

Zero Calibration of Model 6200T, Total sulphide analyzer performed with sample gas flowing through special charcoal scrubber installed in analyzer, which removes the sulphide components in the sample gas & only background gas, which is zero gas to the analyzer. In case no sample gas available, use TS free UHP grade CO<sub>2</sub> through Sample port as zero gas as per above Pneumatic Setup.

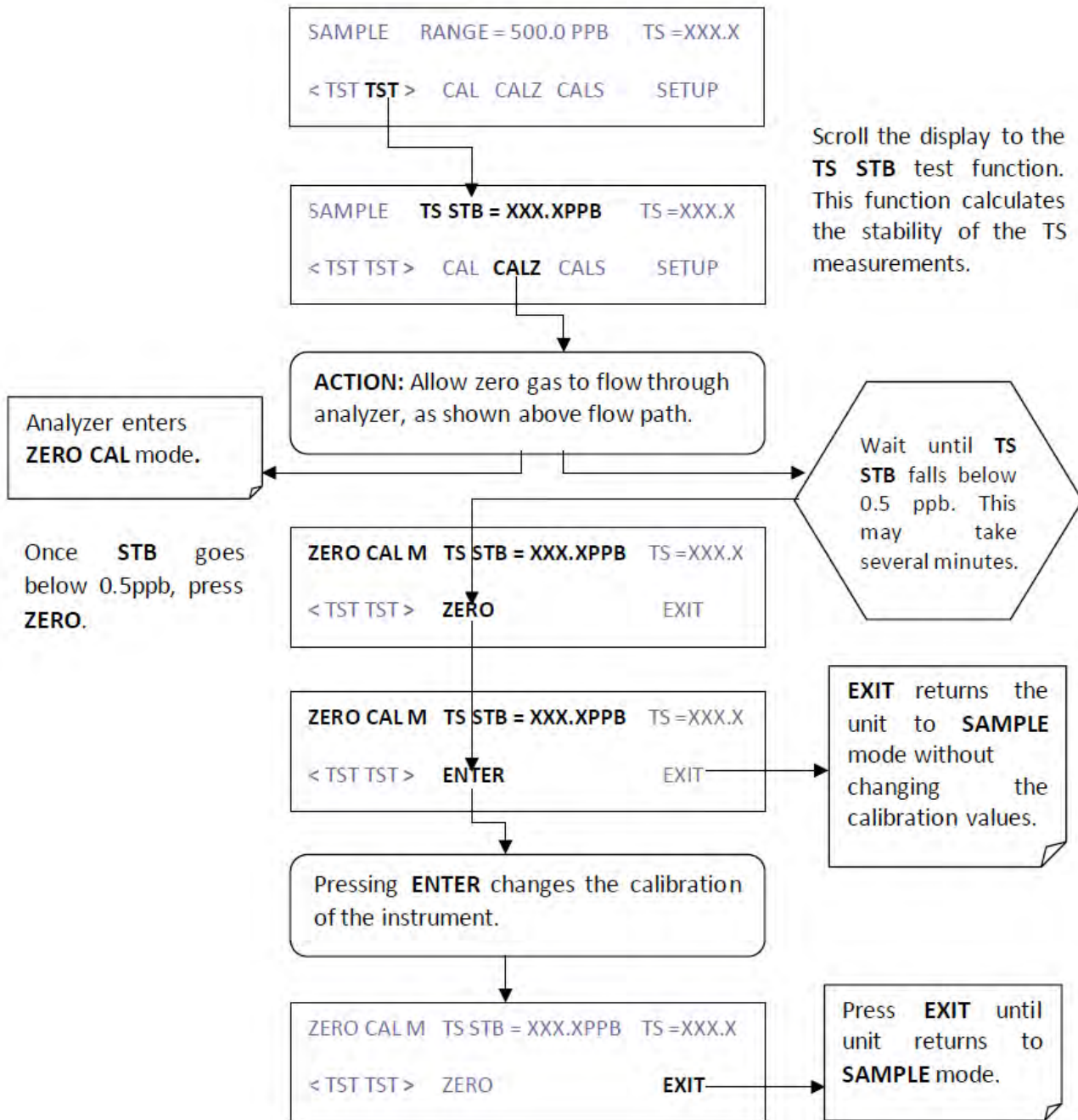

**Figure 3-2212: 6200T, Zero Calibration Procedure**

Span Calibration Procedure

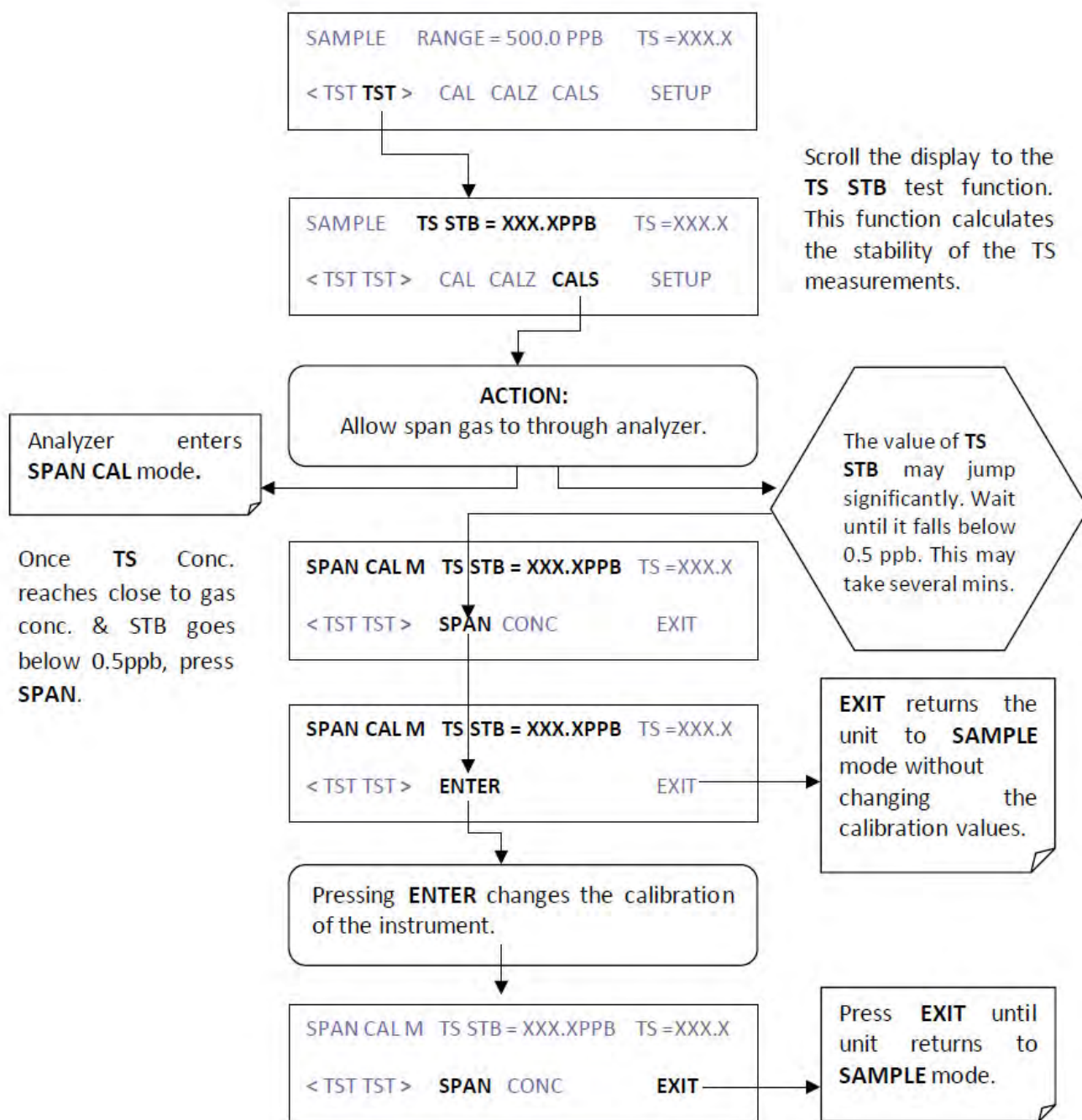

Figure 3-13: 6200T, Span Calibration Procedure





**PART II**  
**OPERATING INSTRUCTIONS**



**This page intentionally left blank.**

## 4. OVERVIEW OF OPERATING MODES

### Note

Some control buttons on the touch screen do not appear if they are not applicable to the menu that you're in, the task that you are performing, the command you are attempting to send, or to incorrect settings input by the user. For example, the ENTR button may disappear if you input a setting that is invalid or out of the allowable range for that parameter, such as trying to set the 24-hour clock to 25:00:00. Once you adjust the setting to an allowable value, the ENTR button will re-appear.

The 6200T software has a variety of operating modes. Most commonly, the analyzer will be operating in SAMPLE mode. In this mode, a continuous read-out of the SO<sub>2</sub> concentration can be viewed on the front panel and output as an analog voltage from rear panel terminals, calibrations can be performed, and TEST functions and WARNING messages can be examined.

The second most important operating mode is SETUP mode. This mode is used for performing certain configuration operations, such as for the DAS system, the reporting ranges, or the serial (RS-232 / RS-485 / Ethernet) communication channels. The SET UP mode is also used for performing various diagnostic tests during troubleshooting.



Figure 4-1: Front Panel Display

The Mode field of the front panel display indicates to the user which operating mode the unit is currently running.

In addition to **SAMPLE** and **SETUP**, other modes available are presented in Table 4-1.



Table 4-1: Analyzer Operating Modes

MODE	EXPLANATION
<b>DIAG</b>	One of the analyzer's diagnostic modes is active (refer to Section 5.9).
<b>LO CAL A<sup>1</sup></b>	Unit is performing LOW SPAN (midpoint) calibration initiated automatically by the analyzer's AUTOCAL feature
<b>LO CAL R<sup>1</sup></b>	Unit is performing LOW SPAN (midpoint) calibration initiated remotely through the COM ports or digital control inputs.
<b>M-P CAL<sup>1</sup></b>	This is the basic calibration mode of the instrument and is activated by pressing the CAL button.
<b>SAMPLE</b>	Sampling normally, flashing text indicates adaptive filter is on.
<b>SAMPLE A</b>	Indicates that unit is in SAMPLE mode and AUTOCAL feature is activated.
<b>SETUP</b>	SETUP mode is being used to configure the analyzer. The gas measurement will continue during this process.
<b>SPAN CAL A<sup>2</sup></b>	Unit is performing SPAN calibration initiated automatically by the analyzer's AUTOCAL feature
<b>SPAN CAL M<sup>2</sup></b>	Unit is performing SPAN calibration initiated manually by the user.
<b>SPAN CAL R<sup>2</sup></b>	Unit is performing SPAN calibration initiated remotely through the COM ports or digital control inputs.
<b>ZERO CAL A<sup>2</sup></b>	Unit is performing ZERO calibration procedure initiated automatically by the AUTOCAL feature
<b>ZERO CAL M<sup>2</sup></b>	Unit is performing ZERO calibration procedure initiated manually by the user.
<b>ZERO CAL R<sup>2</sup></b>	Unit is performing ZERO calibration procedure initiated remotely through the COM ports or digital control inputs.
<sup>1</sup> Other calibration procedures under <b>CAL</b> mode are described separately in Section 8.6.	
<sup>2</sup> Only Appears on units with Z/S valve or IZS options..	

## 4.1. Sample Mode

This is the analyzer's standard operating mode. In this mode, the instrument is analyzing SO<sub>2</sub> and calculating concentrations.

### 4.1.1. Test Functions

A series of test functions is available at the front panel while the analyzer is in **SAMPLE** mode. These parameters provide information about the present operating status of the instrument and are useful during troubleshooting (refer to Section 10.1.2). They can also be recorded in one of the DAS channels (refer to Section 0) for data analysis. To view the test functions, press one of the <TST TST> buttons repeatedly in either direction.

Table 4-2: Test Functions Defined

DISPLAY	PARAMETER	UNITS	DESCRIPTION
A1/A2/A3	RANGE -- RANGE1 RANGE2	PPB, PPM, UGM & MGM	The Full Scale limit at which the reporting range of the analyzer's ANALOG OUTPUTS is currently set. The ANALOG OUTPUTS are set as described in the Configurable Analog Outputs Manual P/N MQ7859. A1/A2/A3 will only appear when the ANALOG OUTPUT is configured as active.
SO2 STB OR TS STB	STABILITY	mV	Standard deviation of SO <sub>2</sub> Concentration readings. Data points are recorded every ten seconds. The calculation uses the last 25 data points.
OXY FLOW	Oxygen Flow	cm <sup>3</sup> /min (cc/m)	The flow rate into the oxygenator.
SAMP FL	SAMPLE FLOW	cm <sup>3</sup> /min (cc/m)	The flow rate of the sample gas through the sample chamber. This value is not measured but calculated from the sample pressure.
PRES	SAMPLE PRESSURE	in-Hg-A	The current pressure of the sample gas as it enters the sample chamber, measured between the SO <sub>2</sub> and Auto-Zero valves.
PMT	PMT Signal	mV	The raw output voltage of the PMT.
NORM PMT	NORMALIZED PMT Signal	mV	The output voltage of the PMT after normalization for offset and temperature/pressure compensation (if activated).
UV LAMP	Source UV Lamp Intensity	mV	The output voltage of the UV reference detector.
LAMP RATIO	UV Source lamp ratio	%	The current output of the UV reference detector divided by the reading stored in the CPU's memory from the last time a UV Lamp calibration was performed.
STR. LGT	Stray Light	Ppb	The offset due to stray light recorded by the CPU during the last zero-point calibration performed.
DRK PMT	Dark PMT	mV	The PMT output reading recorded the last time the UV source lamp shutter was closed.
DRK LMP	Dark UV Source Lamp	mV	The UV reference detector output reading recorded the last time the UV source lamp shutter was closed.
SO2/TS SLOPE	SO <sub>2</sub> measurement Slope	-	The sensitivity of the instrument as calculated during the last calibration activity. The slope parameter is used to set the span calibration point of the analyzer.
SO2/TS OFFSET	SO <sub>2</sub> measurement Offset	mV	The overall offset of the instrument as calculated during the last calibration activity. The offset parameter is used to set the zero point of the analyzer response.
HVPS	HVPS	V	The PMT high voltage power supply.
RCELL TEMP	SAMPLE CHAMBER TEMP	°C	The current temperature of the sample chamber.
BOX TEMP	BOX TEMPERATURE	°C	The ambient temperature of the inside of the analyzer case.
PMT TEMP	PMT TEMPERATURE	°C	The current temperature of the PMT.
IZS TEMP <sup>1</sup>	IZS TEMPERATURE <sup>1</sup>	°C	The current temperature of the internal zero/span option. Only appears when IZS option is enabled.
TEST <sup>2</sup>	TEST SIGNAL <sup>2</sup>	mV	Signal of a user-defined test function on output channel.
TIME	CLOCK TIME	hh:mm:ss	The current day time for DAS records and calibration events.
<sup>1</sup> Only appears if Internal Gas Span Generator option is installed.			
<sup>2</sup> Only appears if analog output is actively reporting a test function.			

To view the TEST Functions press TEST and then cycle through the available functions using the <TST TST> buttons.





**IMPORTANT**

**IMPACT ON READINGS OR DATA**

A value of “XXXX” displayed for any of the TEST functions indicates an out-of-range reading or the analyzer’s inability to calculate it. All pressure measurements are represented in terms of absolute pressure. Absolute, atmospheric pressure is 29.92 in-Hg-A at sea level. It decreases about 1 in-Hg per 300 m gain in altitude. A variety of factors such as air conditioning and passing storms can cause changes in the absolute atmospheric pressure.

**4.1.2. Warning Messages**

The most common instrument failures will be reported as a warning on the analyzer’s front panel and through the COMM ports. Section 10.1.1 explains how to use these messages to troubleshoot problems. Section 10.1.3 shows how to view and clear warning messages. Table 4-3 lists all warning messages for the current version of software.

**Table 4-3: List of Warning Messages**

MESSAGE	MEANING
<b>ANALOG CAL WARNING</b>	The instrument's A/D circuitry or one of its analog outputs is not calibrated.
<b>BOX TEMP WARNING</b>	The temperature inside the 6200T chassis is outside the specified limits.
<b>CANNOT DYN SPAN</b>	Remote span calibration failed while the dynamic span feature was set to turned on
<b>CANNOT DYN ZERO</b>	Remote zero calibration failed while the dynamic zero feature was set to turned on
<b>CONFIG INITIALIZED</b>	Configuration was reset to factory defaults or was erased.
<b>DARK CAL WARNING</b>	Dark offset above limit specified indicating that too much stray light is present in the sample chamber.
<b>DATA INITIALIZED</b>	DAS data storage was erased.
<b>HVPS WARNING</b>	High voltage power supply for the PMT is outside of specified limits.
<b>IZS TEMP WARNING</b>	On units with IZS options installed: The permeation tube temperature is outside of specified limits.
<b>OXY FLOW WARNING</b>	Oxygenation flow is outside the specified limits.
<b>PMT DET WARNING</b>	PMT detector output outside of operational limits.
<b>PMT TEMP WARNING</b>	PMT temperature is outside of specified limits.
<b>RCELL TEMP WARNING</b>	Sample chamber temperature is outside of specified limits.
<b>REAR BOARD NOT DET</b>	The CPU is unable to communicate with the motherboard.
<b>RELAY BOARD WARN</b>	The firmware is unable to communicate with the relay board.
<b>SAMPLE FLOW WARN</b>	The flow rate of the sample gas is outside the specified limits.
<b>SAMPLE PRESS WARN</b>	Sample pressure outside of operational parameters.
<b>SYSTEM RESET</b>	The computer was rebooted.
<b>UV LAMP WARNING</b>	The UV lamp intensity measured by the reference detector reading too low or too high
<b>UUUU</b>	(M501TS Converter) Open thermocouple

To view and clear warning messages, press:

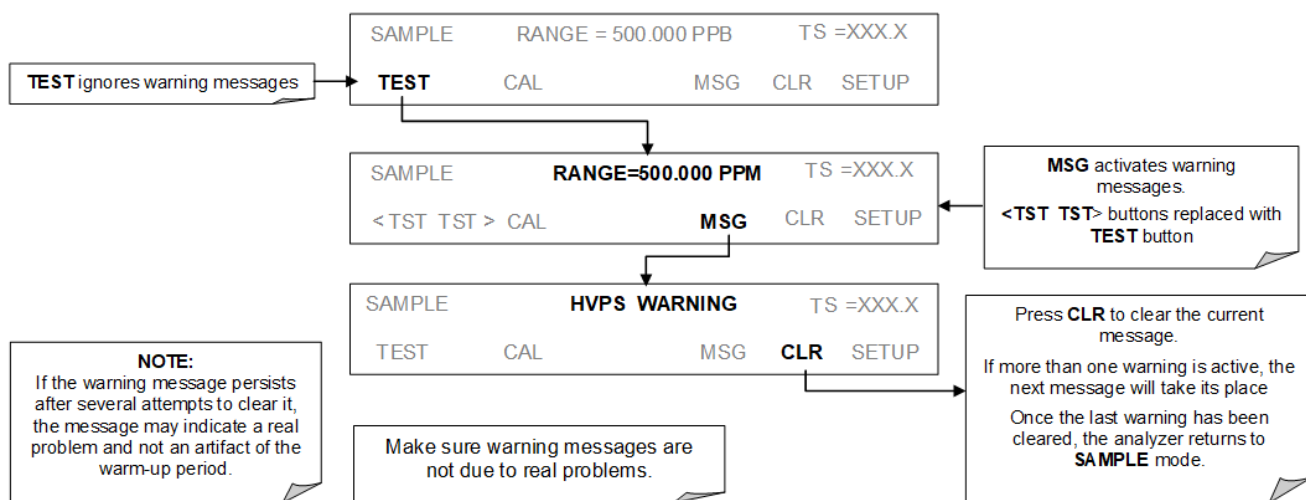

Figure 4-2: Viewing and Clearing 6200T WARNING Messages



## 4.2. Calibration Mode

Pressing the **CAL**, **CALZ**, or **CALS** button switches the analyzer into calibration mode. In this mode, the user can calibrate the instrument with the use of calibrated zero or span gases.

If the instrument includes either the zero/span valve option or IZS option, the display will also include **CALZ** and **CALS** buttons. Pressing either of these buttons also puts the instrument into multipoint calibration mode.

- The **CAL** button initiates multi-point calibration.
- The **CALZ** button is used to initiate a calibration of the zero point.
- The **CALS** button is used to calibrate the span point of the analyzer. It is recommended that this span calibration is performed at 80% of full scale of the analyzer's currently selected reporting range.

Because of their critical importance and complexity, calibration operations are described in detail in other sections of the manual.

### IMPORTANT

#### IMPACT ON READINGS OR DATA

To avoid inadvertent adjustments to critical settings, activate calibration security by enabling password protection in the **SETUP – PASS** menu (Section 5.5).

## 4.3. Setup Mode

The **SETUP** mode contains a variety of choices that are used to configure the analyzer's hardware and software features, perform diagnostic procedures, gather information on the instrument's performance and configure or access data from the internal data acquisition system (DAS). Setup Mode is divided between Primary and Secondary Setup menus and can be protected through password security.

### 4.3.1. Password Security

Setup Mode can be protected by password security through the **SETUP>PASS** menu (Section 5.5) to prevent unauthorized or inadvertent configuration adjustments.

### 4.3.2. Primary Setup Menu

Table 4-4: Primary Setup Mode Features and Functions

MODE OR FEATURE	CONTROL BUTTON	DESCRIPTION	MANUAL SECTION
Analyzer Configuration	<b>CFG</b>	Lists key hardware and software configuration information.	5.1
Auto Cal Feature	<b>ACAL</b>	Used to set up and operate the AutoCal feature. Only appears if the analyzer has one of the internal valve options installed and TAI Protocol is disabled.	5.2 & 8.7
Internal Data Acquisition (DAS)	<b>DAS</b>	Used to set up the DAS system and view recorded data.	5.3, DAS Manual, &, 11.5.4
Range Unit Configuration	<b>RNGE</b>	Used to set the units used for display.	5.4 <sup>1</sup>
Calibration Password Security	<b>PASS</b>	Turns the calibration password protection feature ON/OFF.	5.5
Internal Clock Configuration	<b>CLK</b>	Used to Set or adjust the instrument's internal clock.	5.6
Advanced <b>SETUP</b> features	<b>MORE</b>	This button accesses the instruments secondary setup menu.	See Table 4-5

<sup>1</sup> To change the upper limit of ranges use DIAG/ANALOG I/O CONFIGURATION/DATA OUT [X]/DATA OUT [X] scale:[upper range limit]

### 4.3.3. Secondary Setup Menu (SETUP>MORE)

Table 4-5: Secondary Setup Mode Features and Functions

MODE OR FEATURE	MENU ITEM	DESCRIPTION	MANUAL SECTION
External Communication Channel Configuration	<b>COMM</b>	Used to set up and operate the analyzer's various external I/O channels including RS-232; RS 485, modem communication and/or Ethernet access.	5.7 & 5.9.9
System Status Variables	<b>VARs</b>	Used to view various variables related to the instrument's current operational status	5.8
System Diagnostic Features	<b>DIAG</b>	Used to access a variety of functions that are used to configure, test or diagnose problems with a variety of the analyzer's basic systems	5.9

#### IMPORTANT

#### IMPACT ON READINGS OR DATA

Any changes made to a variable during the **SETUP** procedures are not acknowledged by the instrument until the **ENTR** button is pressed. If the **EXIT** button is pressed before the **ENTR** button, the analyzer will beep, alerting the user that the newly entered value has not been accepted.





**This page intentionally left blank.**



## 5. SETUP MENU

The SETUP menu is used to set instrument parameters for performing configuration, calibration, reporting and diagnostics operations according to user needs.

### 5.1. SETUP – CFG: Configuration Information

Pressing the CFG button displays the instrument configuration information. This display lists the analyzer model, serial number, firmware revision, software library revision, CPU type and other information. Use this information to identify the software and hardware when contacting customer service. Special instrument or software features or installed options may also be listed here. To view these items press CFG from the main display and then NEXT to cycle through the Configuration display items. Press EXIT to return to the Primary Setup Menu.



The CFG list depends on the options installed. The following items may be present:

- Model Name
- Part Number
- Serial Number
- Software Revision
- Library Revision

### 5.2. SETUP – ACAL: Automatic Calibration Option

The menu button for this option appears only when the instrument has the zero span and/or IZS options and TAI Protocol is disabled under the COMM menu. See Section 8.7 for details.

### 5.3. SETUP – DAS: Internal Data Acquisition System

Use the SETUP>DAS menu to capture and record data. Refer to Section 07 for configuration and operation details.

## 5.4. SETUP – RNGE: Range Configuration

Use the Range (Rnge) function from the SETUP menu to set the units used for reporting analysis results. This function is also used to set or change the dilution ratio on instruments configured with the dilution option.

**Note** Additional information can be found in the separate manual entitled *Configurable Analog Output for Teledyne T-Series Analyzers*.

**Note** The upper limits of the ranges can be changed using the Scale subfunction in the DIAG menu as follows: DIAG>ANALOG I/O CONFIGURATION>DATA OUT [X] >DATA OUT [X] Scale.

### 5.4.1. Range Units

The 6200T can display concentrations in parts per billion ( $10^9$  mols per mol, PPB), parts per million ( $10^6$  mols per mol, PPM), micrograms per cubic meter ( $\mu\text{g}/\text{m}^3$ , UGM) or milligrams per cubic meter ( $\text{mg}/\text{m}^3$ , MGM). Changing units affects all of the display, analog outputs, COM port and DAS values for all reporting ranges regardless of the analyzer's range mode.

To change the concentration units press SETUP>RNGE>UNIT from the main screen.



**IMPORTANT**

#### IMPACT ON READINGS OR DATA

Concentrations displayed in  $\text{mg}/\text{m}^3$  and  $\mu\text{g}/\text{m}^3$  use  $0^\circ\text{C}$  and 760 Torr as standard temperature and pressure (STP). Consult your local regulations for the STP used by your agency. Here are the conversion factors from volumetric to mass units used in the 6200T:  $\text{SO}_2$ :  $\text{ppb} \times 1.34 = \mu\text{g}/\text{m}^3$ ;  $\text{ppm} \times 1.34 = \text{mg}/\text{m}^3$





### 5.4.2. Dilution Ratio (Option)

The dilution ratio is a software option that allows the user to compensate for any dilution of the sample gas before it enters the sample inlet. Once the degree of dilution is known, an appropriate scaling factor is added to the analyzer's SO<sub>2</sub> concentration calculation so that the measurement range and concentration values reflect the undiluted values when shown on the instrument's front panel display screen and reported via the analog and serial outputs.

Using the dilution ratio option is a 4-step process:

1. Select reporting range units: Follow the procedure in Section 5.4.1
2. Select the range: Use the procedures in Section 5.4. Ensure that the SPAN value entered is the maximum expected concentration of the undiluted calibration gas and that the span gas is either supplied through the same dilution inlet system as the sample gas or has an appropriately lower actual concentration. For example, with a dilution set to 100, a 1 ppm gas can be used to calibrate a 100 ppm sample gas if the span gas is not routed through the dilution system. On the other hand, if a 100 ppm span gas is used, it needs to pass through the same dilution steps as the sample gas.
3. Set the dilution factor as a gain (e.g., a value of 20 means 19 parts diluent and 1 part of sample gas):

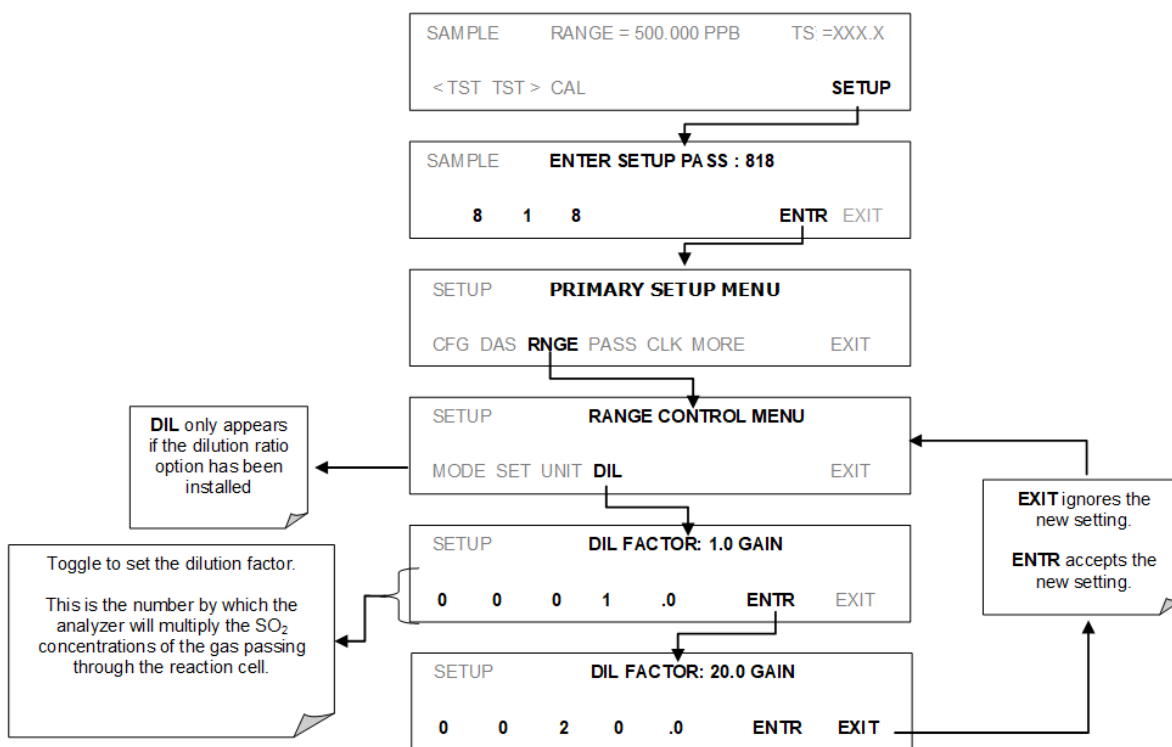

**Figure 5-1: SETUP RNGE – Dilution Ratio**

The analyzer multiplies the measured gas concentrations with this dilution factor and displays the result.

#### IMPORTANT

#### IMPACT ON READINGS OR DATA

Once the above settings have been entered, the instrument needs to be recalibrated.

### 5.5. SETUP – PASS: Password Protection

The menu system provides password protection of the calibration and setup functions to prevent unauthorized adjustments. When the passwords have been enabled in the **PASS** menu item, the system will prompt the user for a password anytime a password-protected function (e.g., SETUP) is selected. This allows normal operation of the instrument, but requires the password (101) to access to the menus under SETUP. When PASSWORD is disabled (SETUP>OFF), any operator can enter the Primary Setup (SETUP) and Secondary Setup (SETUP>MORE) menus. Whether PASSWORD is enabled or disabled, a password (default 818) is required to enter the VARS or DIAG menus in the SETUP>MORE menu.

**Table 5-1: Password Levels**

PASSWORD	LEVEL	MENU ACCESS ALLOWED
Null (000)	Operation	All functions of the main menu (top level, or Primary, menu)
101	Configuration/Maintenance	Access to Primary and Secondary SETUP Menus when PASSWORD is enabled
818	Configuration/Maintenance	Access to Secondary SETUP Submenus <b>VARS</b> and <b>DIAG</b> whether PASSWORD is enabled or disabled.

To enable or disable passwords, press:

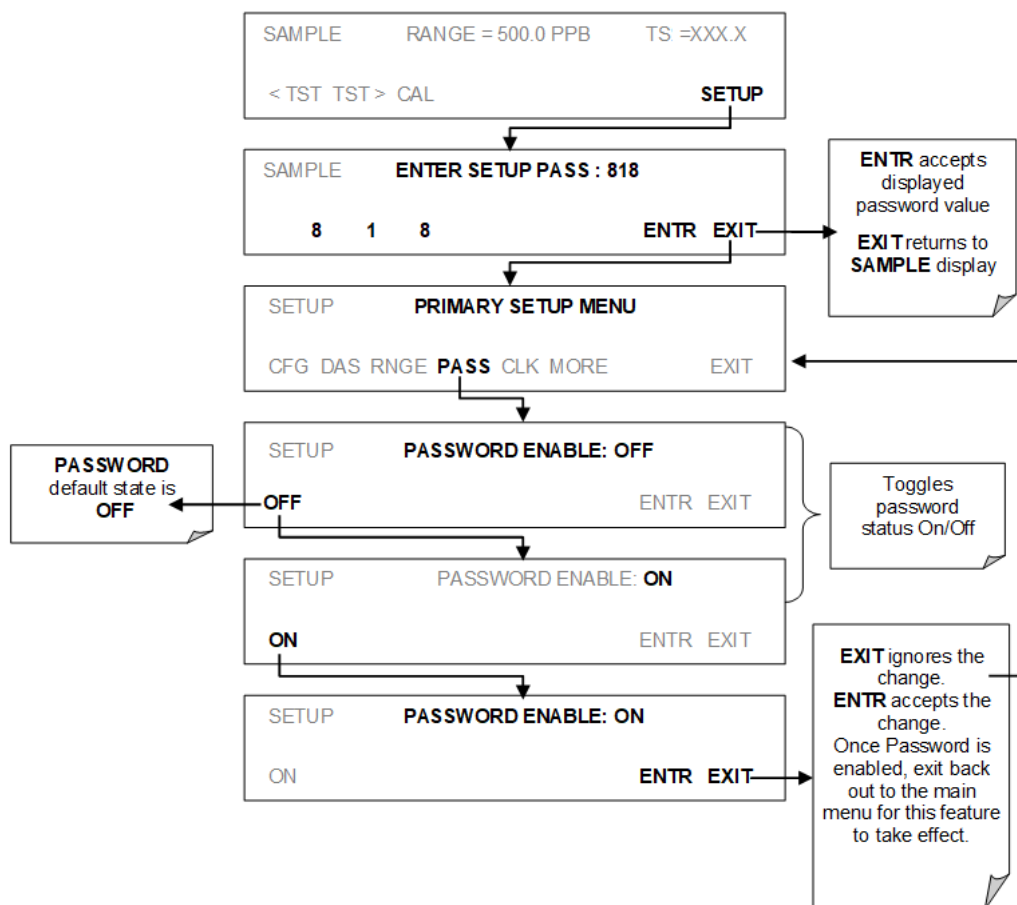
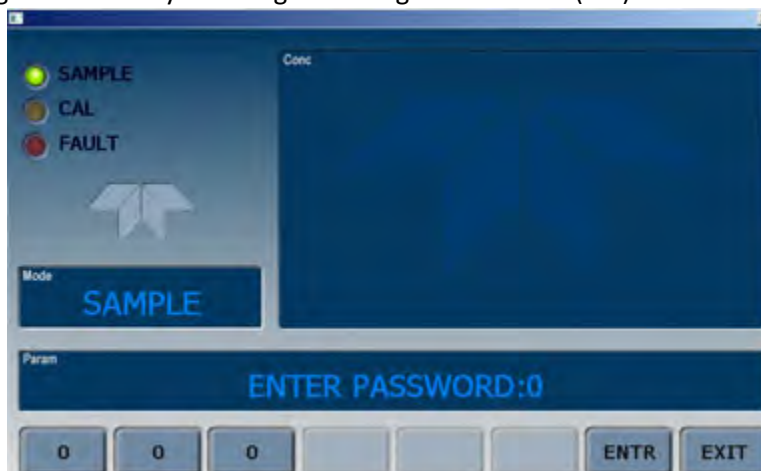

**Figure 5-2: SETUP – Enable Password Security**



If the password feature is enabled, then when entering either Calibration or Setup Mode, the default password displayed will be 000, and the new password must be input. For example, attempting to enter the calibration mode requires a password. Pressing CAL will produce the following screen:

Press each digit button to cycle through the range of numbers (0-9) until the correct 3-digit password is



displayed. Then press ENTR. to advance to the calibration screen or press EXIT to discard the input and return to the main screen.

## 5.6. SETUP – CLK: Setting the Internal Time-of-Day Clock

The 6200T has a built-in clock for the AutoCal timer, Time **TEST** functions, and time stamps on COM port messages and DAS data entries. To set the time-of-day or date, enter the Primary Setup Menu by pressing the SETUP button and then go to the Clock function by pressing CLK. The following screen will appear:

Select either TIME or DATE to modify the existing value

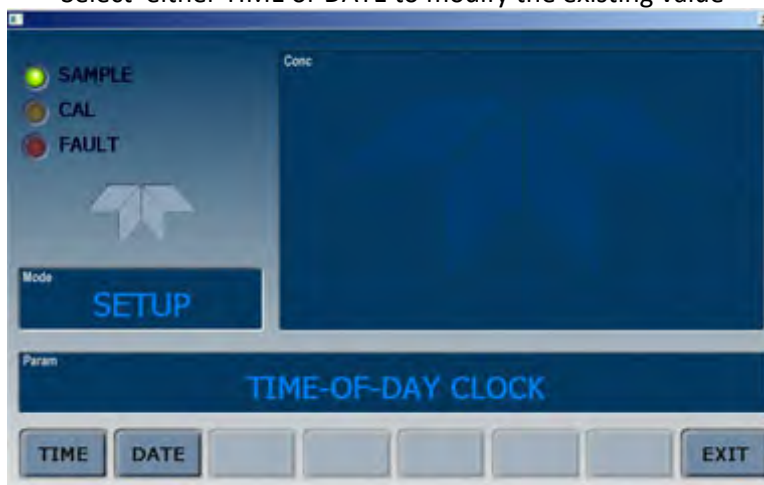

### 5.6.1. Time of Day

For time adjustment use the numerical buttons to set the time.



When the correct time is displayed press ENTR to accept the input or EXIT to cancel the input and revert back to the previous screen without any change to the time.



### 5.6.2. Date

To change the date, press DATE from the CLK screen. Use the row of buttons along the bottom to change the date, month, and year. Press ENTR to accept the input or EXIT to cancel the input and revert back to the previous screen without any change to the time.



### 5.6.3. Clock Adjust

In order to compensate for CPU clocks, which may run fast or slow, there is a variable to speed up or slow down the clock by a fixed amount every day. The Clock Adjust function is located in the VARS menu. To enter the Clock Adjust function, enter SETUP, press MORE, and then VARS. You will need to enter a password if password protection is enabled. After entering the password, press NEXT repeatedly until the Clock Adjust function is displayed. Alternatively you can use the JUMP button and then enter 11 and ENTR to move directly to the Clock Adjust Function.

Press EDIT to make changes to the clock speed. The following screen will appear:

Enter the adjustment to the clock (+ or -) and then press ENTR to alter the clock speed or EXIT to discard the change.



## 5.7. SETUP – COMM: Communications Ports

This section introduces the communications setup menu; Section 6.2 provides the setup instructions and operation information. Press SETUP>>MORE>COMM to arrive at the communications menu.



### 5.7.1. ID (Instrument Identification)

Press ID to display and/or change the Machine ID, which must be changed to a unique identifier when more than one instrument of the same model is used with MODBUS protocol (only for analyzers with the optional Modbus software installed). The default ID for the 6200T is 0100. Use the number button(s) in the MACHINE ID menu to set the Machine ID Parameter field so it displays the desired identifier. Press ENTR to accept and save the ID or EXIT to abandon the entry and return to the COMM menu.



The ID can be any 4-digit number and can also be used to identify analyzers in any number of ways (e.g. location numbers, company asset number, etc.)

### 5.7.2. INET (Ethernet)

Use SETUP>COMM>INET to configure Ethernet communications, whether manually or via DHCP. Please see Section 6.4 for configuration details.

### 5.7.3. COM1 and COM2 (Mode, Baud Rate and Test Port)

Use the SETUP>COMM>COM1[COM2] menus to:

- Configure communication modes (Section **Error! Reference source not found.**)
- View/set the baud rate (Section 6.2.2)
- Test the connections of the com ports (Section 6.2.3).

Configuring COM1 or COM2 requires setting the DCE DTE switch on the rear panel. Section 6.1 provides DCE DTE information.

## 5.8. SETUP – VARS: Variables Setup and Definition

Through the SETUP>MORE>VARS menu there are several-user adjustable software variables that define certain operational parameters. Usually, these variables are automatically set by the instrument's firmware, but can be manually re-defined using the VARS menu. Table 5-2 lists all variables that are available within the 818 password protected level.

**Table 5-2: Variable Names (VARS) Revision G.3**

NO.	VARIABLE	DESCRIPTION	ALLOWED VALUES
0	MEASURE_MODE	Sets the measured parameter: SO <sub>2</sub> , TS, and remote	SO <sub>2</sub> , TS, SO <sub>2</sub> -TS, SO <sub>2</sub> -TS-Remote, TS-SO <sub>2</sub> -Remote,
1	CAL_GAS	Sets the calibration gas used: SO <sub>2</sub> /TS.	SO <sub>2</sub> , TS
2	DAS_HOLD_OFF	Changes the internal data acquisition system (DAS) hold-off time, which is the duration when data are not stored in the DAS because the software considers the data to be questionable. That is the case during warm-up or just after the instrument returns from one of its calibration modes to SAMPLE mode. DAS_HOLD_OFF can be disabled entirely in each DAS channel.	Can be between 0.5 and 20 minutes Default=15 min.
3	TPC_ENABLE	Enables or disables the temperature and pressure compensation (TPC) feature (refer to Section 11.5.3).	ON/OFF
4	RCELL_SET	Sets the sample chamber temperature. Increasing or decreasing this temperature will increase or decrease the rate at which SO <sub>2</sub> * decays into SO <sub>2</sub> (refer to Section 11.1.1). Do not adjust this setting unless under the direction of Teledyne Analytical Instruments customer service personnel.	30° C - 70° C Default= 50° C
5	IZS_SET	Sets the IZS option temperature. Increasing or decreasing this temperature will increase or decrease the permeation rate of the IZS source (refer to Section <b>Error! Reference source not found.</b> ).	30° C - 70° C Default= 50° C
6	DYN_ZERO	Dynamic zero automatically adjusts offset and slope of the SO <sub>2</sub> response when performing a zero point calibration during an AutoCal.	ON/OFF
7	DYN_SPAN	Dynamic span automatically adjusts slope and slope of the SO <sub>2</sub> response when performing a zero point calibration during an AutoCal. Note that the DYN_ZERO and DYN_SPAN features are not allowed for applications requiring EPA equivalency.	ON/OFF
8	CONC_PRECISION	Allows the user to set the number of significant digits to the right of the decimal point display of concentration and stability values.	AUTO, 1, 2, 3, 4 Default=AUTO
9	STAT_REP_GAS	Selects the gas which is reported via TAI communications protocol.	SO <sub>2</sub> , TS
10	REM_CAL_DURATION	Sets the duration for remote calibration hold.	1 - 120 minutes
11	CLOCK_ADJ	Adjusts the speed of the analyzer's clock. Choose the + sign if the clock is too slow, choose the - sign if the clock is too fast.	-60 to +60 s/day
12	SERVICE_CLEAR=OFF		ON/OFF
13	TIME_SINCE_SVC	Displays the time since the last service was performed.	n/a
14	SVC_INTERVAL=0 HRS	Displays the user defined service interval in hours	0 – 99999 hours

To access and navigate the VARS menu, use the following button sequence. Press SETUP>MORE>VARS and then enter your password to enter the VARS menu.







## 5.9. SETUP – DIAG: Diagnostics Functions

The SETUP>MORE>DIAG menu provides a series of diagnostic functions whose parameters are dependent on firmware. **Error! Reference source not found.** describes the functions and provides a cross-reference to the details for each in the remainder of this section. These functions can be used as tools in a variety of troubleshooting and diagnostic procedures.

DIAGNOSTIC FUNCTION AND MEANING	FRONT PANEL MODE INDICATOR	SECTION
<b>SIGNAL I/O:</b> Allows observation of all digital and analog signals in the instrument. Allows certain digital signals such as valves and heaters to be toggled ON and OFF.	DIAG I/O	5.9.1
<b>ANALOG OUTPUT:</b> When entered, the analyzer performs an analog output step test. This can be used to calibrate a chart recorder or to test the analog output accuracy.	DIAG AOUT	5.9.2
<b>ANALOG I/O CONFIGURATION:</b> Analog input/output parameters are available for viewing and configuration.	DIAG AIO	5.9.3
<b>OPTIC TEST:</b> When activated, the analyzer performs an optic test, which turns on an LED located inside the sensor module near the PMT (Fig. 10-15). This diagnostic tests the response of the PMT without having to supply span gas.	DIAG OPTIC	5.9.4
<b>ELECTRICAL TEST:</b> When activated, the analyzer performs an electric test, which generates a current intended to simulate the PMT output to verify the signal handling and conditioning of the PMT preamp board.	DIAG ELEC	5.9.5
<b>LAMP CALIBRATION:</b> The analyzer records the current voltage output of the UV source reference detector. This value is used by the CPU to calculate the lamp ration used in determining the SO <sub>2</sub> concentration	DIAG LAMP	5.9.6
<b>PRESSURE CALIBRATION:</b> The analyzer records the current output of the sample gas pressure sensor. This value is used by the CPU to compensate the SO <sub>2</sub> concentration when the TPC feature is enabled.	DIAG PCAL	5.9.7
<b>FLOW CALIBRATION:</b> This function is used to calibrate the gas flow output signals of sample gas and ozone supply. These settings are retained when exiting DIAG.	DIAG FCAL	5.9.8
<b>DISPLAY SEQUENCE CONFIG:</b> Select the gas concentrations to display on the main screen.	DIAG DISP	5.9.9
<b>STABILITY MEASUREMENT:</b> Change the filtering applied to calculate stability (not recommended).	DIAG STBL	(call factory)

Table 5-3: 6200T Diagnostic (DIAG) Functions

To access the **DIAG** functions press the following buttons: **SETUP>MORE>DIAG** and then enter your password to enter the DIAG menu. The first function in the DIAG menu will display (SIGNAL I/O).



### 5.9.1. Signal I/O

The signal I/O diagnostic mode allows a user to review and change the digital and analog input/output functions of the analyzer. Depending on the options installed in the analyzer there are up to 73 available functions from the SIGNAL I/O menu.

#### IMPORTANT

#### IMPACT ON READINGS OR DATA

**Any changes of signal I/O settings will remain in effect only until the signal I/O menu is exited. Exceptions are the ozone generator override and the flow sensor calibration, which remain as entered when exiting.**

Access the signal I/O test mode from the DIAG Menu, then press ENTR:

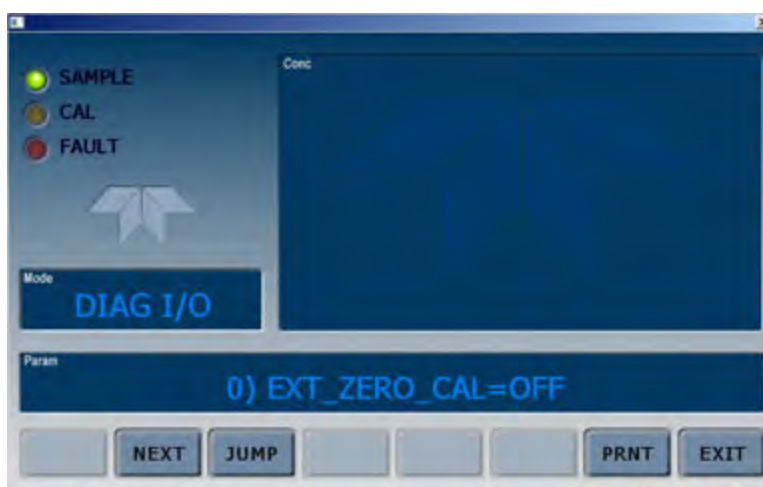

The available actions are:

- **NEXT:** Advances display to the next SIGNAL I/O function.
- **JUMP:** Moves to a specific function. **PRNT:** Sends a formatted printout to the serial port which can be captured with a computer or other output device.



- ON/OFF: Toggles the function ON or OFF. If the feature (option) is not present in the analyzer, this button will not be present.

### 5.9.2. Analog Output Step Test

Analog Output is used as a step test to check the accuracy and proper operation of the analog outputs. The test forces all four analog output channels to produce signals ranging from 0% to 100% of the full scale range in 20% increments. This test is useful to verify the operation of the data logging/recording devices attached to the analyzer.

Access the Analog Output Step Test from the DIAG Menu. After entering the password press NEXT to advance to the ANALOG OUTOUT test screen.



Press ENTR to display the Analog Output test screen.



This performs a test of the analog output signal. In a few seconds the output will cycle from 0% through 100% as indicated on the button. Pressing the button during the test will hold the output at that level and brackets will appear around the value. Pressing the button again will resume the test. When the test is finished, press EXIT to return to the Analog Output main menu.

### 5.9.3. Analog I/O Configuration

The Analog Output from the 6200T is user configurable. Refer to the separate document Configurable Analog Output Addendum MQ7859 for detailed information and procedures for configuring the outputs.

#### 5.9.3.1. Analog Input (AIN) Calibration

This is the sub-menu to conduct the analog input calibration. This calibration should only be necessary after major repair such as a replacement of CPU, motherboard or power supplies. Navigate to the **ANALOG I/O CONFIGURATION MENU** from the DIAG Menu by entering the password and then pressing NEXT repeatedly until the ANALOG I/O CONFIGURATION function is shown.



Then press ENTR to enter the Configuration menu. Press SET repeatedly until AIN CALIBRATED: YES/NO is displayed.



Press CAL and the instrument will calibrate automatically. When finished the display will indicate AIN CALIBRATED: YES to indicate a successful calibration. Press EXIT to return to the AIN CONFIGURATION screen.



### 5.9.3.2. Analog Inputs (XIN1...XIN8) Option Configuration

To configure the analyzer's **optional analog inputs** define for each channel:

- Gain (number of units represented by 1 volt)
- Offset (volts)
- Engineering units to be represented in volts (each press of the touchscreen button scrolls the list of alphanumeric characters from A-Z and 0-9) Whether to display the channel in the Test functions

### 5.9.3.3. Analog Output (AOUT) Calibration

Use the same procedure to adjust settings for the Analog Output parameters as well as calibration. From the ANALOG I/O CONFIGURATION menu screen press ENTR to display the AOUTS CALIBRATED: YES/NO screen and then SET. The first of 4 data output screens will display.



Here it is possible to change the output format: voltage: (0.1V, 1V, 5V, 10V) or current (4-20mA). Press EDIT to change the output format and then select the appropriate button. When the correct format is shown, press ENTR to return to the DATA\_OUT\_1 screen or EXIT to discard the change and return to the DATA\_OUT\_1 screen.

Use the same procedure to adjust the additional outputs that may be installed on the analyzer. Press SET from the DATA\_OUT\_1 screen to move to the DATA\_OUT\_2 screen and so forth through DATA\_OUT\_4.

### 5.9.4. Optic Test

The optic test function tests the response of the PMT sensor by turning on an led located in the cooling block of the PMT (refer to Figure 11-15).

The analyzer uses the light emitted from the LED to test its photo-electronic subsystem, including the PMT and the current to voltage converter on the pre-amplifier board. To ensure that the analyzer measures only the light coming from the LED, the analyzer should be supplied with zero air. The optic test should produce a PMT signal of about  $2000 \pm 1000$  mV. Access the Optic Test function from the DIAG menu, then after entering the password press NEXT repeatedly until OPTIC TEST is displayed.



Press ENTR to start the OPTIC TEST and then press TST repeatedly until PMT is displayed. While the Optic Test is activated, the PMT value should be 2000 mV  $\pm$ 1000 mV.

#### IMPORTANT

#### IMPACT ON READINGS OR DATA

**This is a coarse test for functionality and not an accurate calibration tool. The resulting PMT signal can vary significantly over time and also changes with low-level calibration.**

### 5.9.5. Electrical Test

The electrical test function creates a current, which substitutes the PMT signal, and feeds it into the preamplifier board. This signal is generated by circuitry on the pre-amplifier board itself and tests the filtering and amplification functions of that assembly along with the A/D converter on the motherboard. It does not test the PMT itself. The electrical test should produce a PMT signal of about 2000  $\pm$ 1000 mV. Access the Electrical Test from the DIAG Menu by pressing NEXT until ELECTRICAL TEST appears.

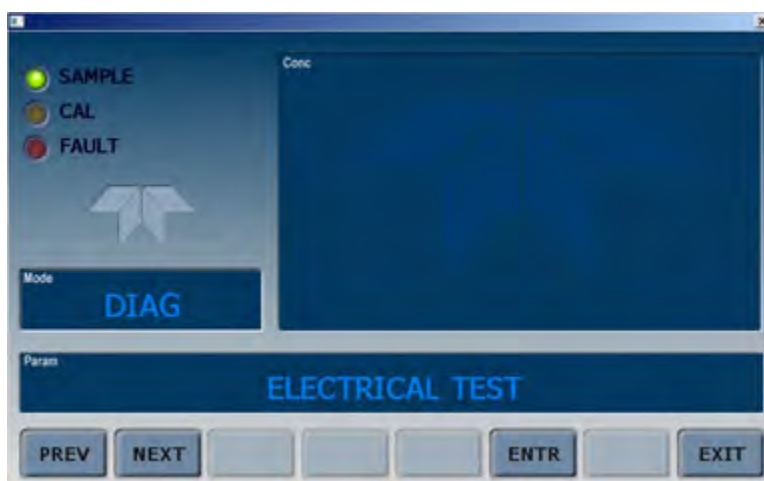

Press ENTR and then TST repeatedly until the PMT screen appears. The indicated PMT value should fall between 1000-3000 mV.



### 5.9.6. Lamp Calibration

An important factor in accurately determining SO<sub>2</sub> concentration is the amount of UV light available to transform the SO<sub>2</sub> into SO<sub>2</sub>\* (refer to Section 11.1.1). The 6200T compensates for variations in the intensity of the available UV light by adjusting the SO<sub>2</sub> concentration calculation using a ratio (**LAMP RATIO**) that results from dividing the current UV lamp (**UV LAMP**) intensity by a value stored in the CPU's memory (**LAMP\_CAL**). Both LAMP Ratio and UV Lamp are test functions viewable from the instruments front panel.

To have the analyzer measure and record a value for **LAMP\_CAL**, access the DIAG Menu, then press NEXT until LAMP CALIBRATION appears on the display.

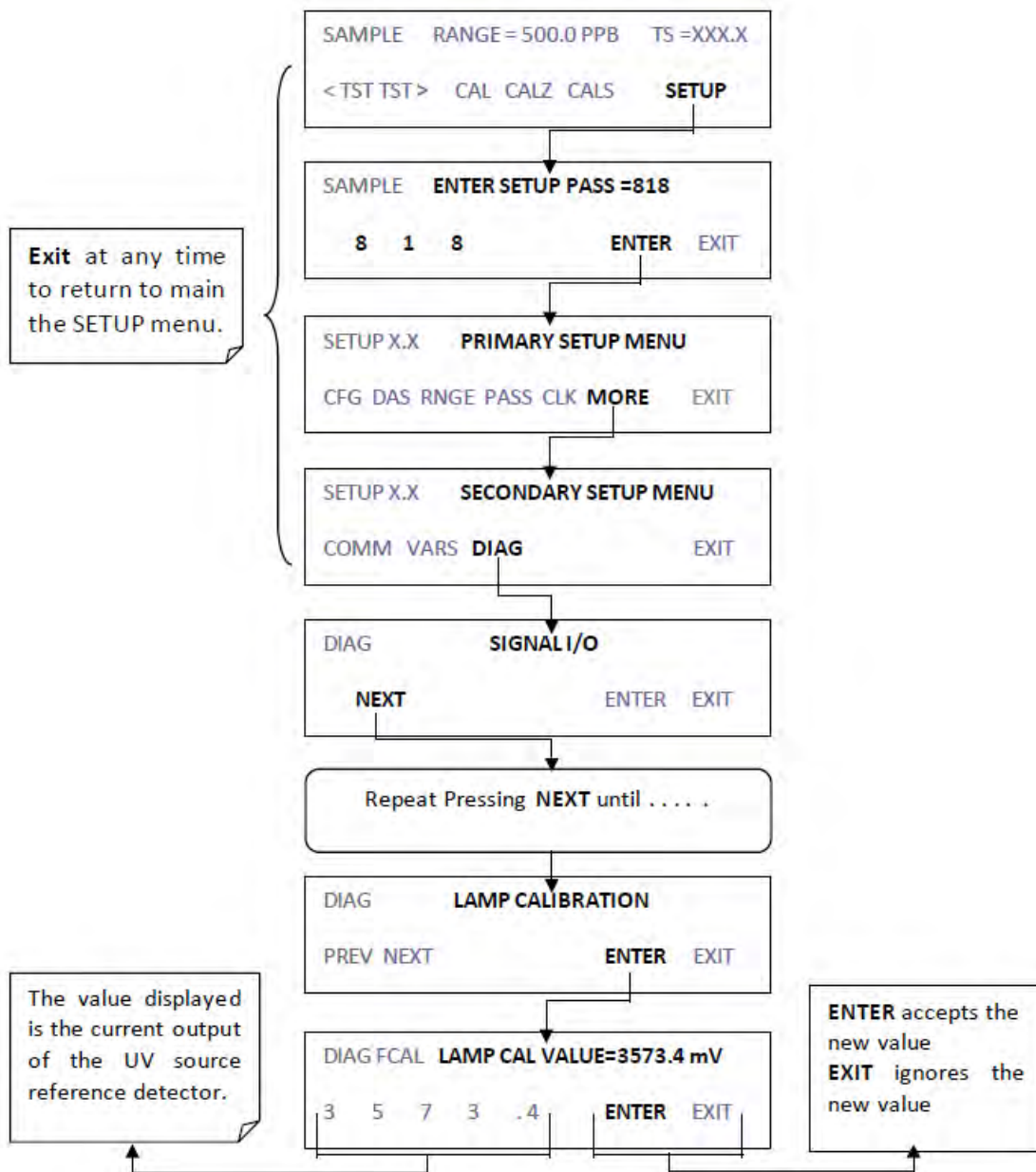

### 5.9.7. Pressure Calibration

A sensor at the exit of the sample chamber continuously measures the pressure of the sample gas. This data is used to compensate the final TS concentration calculation for changes in atmospheric pressure when the instrument's TPC feature is turned on (refer to Section 10.7.3) and is stored in the CPU's memory as the test function **PRES** (also viewable via the front panel).

Ensure to use a barometer that measures actual barometric pressure.

To have the analyzer measure and record a value for **PRES**, access the DIAG Menu then press NEXT until PRESSURE CALIBRATION is displayed.



Press ENTR to view the pressure of the sample gas. Use the numerical buttons to adjust the displayed pressure to correspond to an independently acquired pressure measurement.



Press ENTR to save the edited value or EXIT to return to the PRESSURE CALIBRATION screen without saving any changes.





### 5.9.8. Flow Calibration

The flow calibration allows the user to adjust the values of the sample flow rates as they are displayed on the front panel and reported through COM ports to match the actual flow rate measured at the sample inlet. This does not change the hardware measurement of the flow sensors, only the software calculated values.

To carry out this adjustment, connect an external, sufficiently accurate flow meter to the SAMPLE inlet.

Once the flow meter is attached and is measuring actual gas flow, access the the DIAG Menu, then press NEXT until FLOW CALIBRATION appears on the display.



Press ENTR and then choose which flow sensor to calibrate: SAMPLE or OXY.

A screen will appear that allows the user to adjust the flow rates that are displayed on the front panel. Use the numerical buttons to adjust the flow rate until the display matches the flow rate as measured by the independent flow meter. When finished, press ENTR to save the value or EXIT to return to the FLOW CALIBRATION screen without saving any changes.

### 5.9.9. Display Sequence Config

Use this feature to change the concentration values which are displayed on the main screen.

Press NEXT/PREV to cycle through the values which will be displayed.

Use the INS/DEL/EDIT buttons to insert, delete, or modify an entry.

When modifying an entry, press NEXT/PREV to select the value to display (SO<sub>2</sub>, SO<sub>2</sub>L, SO<sub>2</sub>H, TS, TSH, TSL), then press ENTR. Select a duration in seconds and press ENTR.

**This page intentionally left blank.**



## 6. COMMUNICATIONS SETUP AND OPERATION

This instrument rear panel connections include an Ethernet port, a USB port (option) and two serial communications ports (labeled **RS232**, which is the COM1 port, and **COM2**) located on the rear panel (refer to Figure 3-4). These ports give the user the ability to communicate with, issue commands to, and receive data from the analyzer through an external computer system or terminal.

This section provides pertinent information regarding communication equipment, describes the instrument's communications modes, presents configuration instructions for the communications ports, and provides instructions for their use, including communications protocol. Data acquisition is presented in Section .

### 6.1. Data Terminal / Communication Equipment (DTE DCE)

RS-232 was developed for allowing communications between data terminal equipment (DTE) and data communication equipment (DCE). Basic terminals always fall into the DTE category whereas modems are always considered DCE devices. The difference between the two is the pin assignment of the Data Receive and Data Transmit functions.

- DTE devices receive data on pin 2 and transmit data on pin 3.
- DCE devices receive data on pin 3 and transmit data on pin 2.

To allow the analyzer to be used with terminals (DTE), modems (DCE) and computers (which can be either), a switch mounted below the serial ports on the rear panel allows the user to set the RS-232 configuration for one of these two data devices. This switch exchanges the Receive and Transmit lines on RS-232 emulating a cross-over or null-modem cable. The switch has no effect on COM2.

### 6.2. Communication Modes, Baud Rate and Port testing

Use the SETUP>MORE>COMM menu to configure COM1 (labeled **RS232** on instrument rear panel) and/or COM2 (labeled **COM2** on instrument rear panel) for communication modes, baud rate and/or port testing for correct connection. If using a USB option communication connection, setup requires configuring the COM2 baud rate (Section 6.2.2).

#### 6.2.1. Communication Modes

Either of the analyzer's serial ports (**RS232** or **COM2** on rear panel) can be configured to operate in a number of different modes, which are described in the table below.

To enter the mode menu select COMM from the SECONDARY SETUP menu then press COM1 or COM2. Press the EDIT button and then cycle through the available modes using the NEXT or PREV button.

Table 6-1: COMM Port Communication Modes

MODE <sup>1</sup>	ID	DESCRIPTION
QUIET	1	Quiet mode suppresses any feedback from the analyzer (DAS reports, and warning messages) to the remote device and is typically used when the port is communicating with a computer program such as APICOM. Such feedback is still available but a command must be issued to receive them.
COMPUTER	2	Computer mode inhibits echoing of typed characters and is used when the port is communicating with a computer program, such as APICOM.
TAI PROTOCOL	16	TAI communications protocol is the standard protocol for our analyzers and is required for use with our Valve Boxes.
E, 8, 1	8192	Set COMM port to Even parity, 8 data bits, and 1 stop bit.
E, 7, 1	2048	Set COMM port to Even parity; 7 data bits; 1 stop bit
SECURITY	4	When enabled, the serial port requires a password before it will respond. The only command that is active is the help screen (? CR).
MULTIDROP PROTOCOL	32	Multidrop protocol allows a multi-instrument configuration on a single communications channel. Multidrop requires the use of instrument IDs.
ENABLE MODEM	64	Enables sending a modem initialization string at power-up. Asserts certain lines in the RS-232 port to enable the modem to communicate.
ERROR CHECKING <sup>2</sup>	128	Fixes certain types of parity errors at certain Hessen protocol installations.
XON/XOFF HANDSHAKE <sup>2</sup>	256	Disables XON/XOFF data flow control also known as software handshaking.
HARDWARE HANDSHAKE	8	Enables CTS/RTS style hardwired transmission handshaking. This style of data transmission handshaking is commonly used with modems or terminal emulation protocols as well as by Teledyne Instrument's APICOM software.
HARDWARE FIFO <sup>2</sup>	512	Improves data transfer rate when one of the COMM ports.
COMMAND PROMPT	4096	Enables a command prompt when in terminal mode.

<sup>1</sup> Modes are listed in the order in which they appear in the  
SETUP → MORE → COMM → COM[1 OR 2] → MODE menu

<sup>2</sup> The default setting for this feature is **ON**. Do not disable unless instructed to by Teledyne Analytical Instruments's Customer Service personnel.



To turn on or off the communication modes for either COM1 or COM2, access the SETUP>MORE>[COM1 or COM2] menu and at the COM1[2] Mode menu press EDIT.



Press NEXT to cycle through the available modes. Press ENTR to enable or disable the mode.

### 6.2.2. COMM Port Baud Rate

To select the baud rate of either COMM Port, go to SETUP>MORE>COMM and select either COM1 or COM2 as follows (use COM2 to view/match your personal computer baud rate when using the USB port, Section 6.4.3):

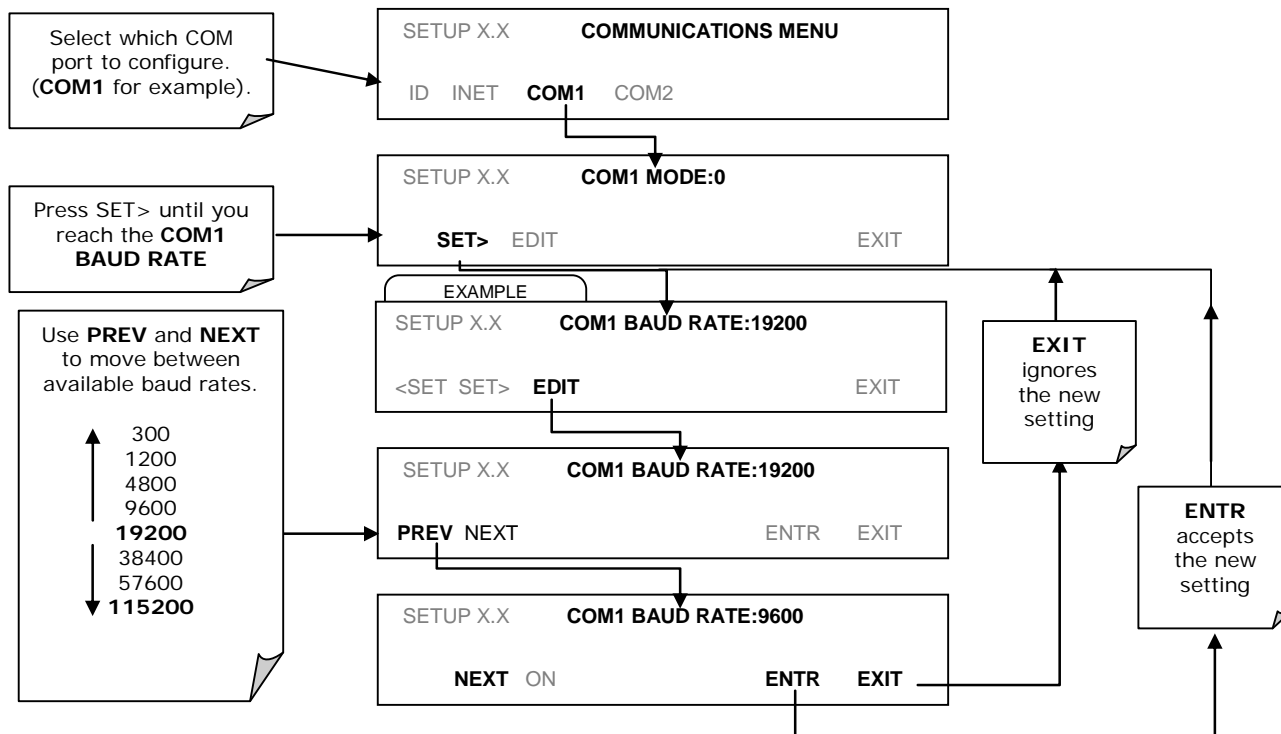

Figure 6-1: COMM – COMM Port Baud Rate



### 6.2.3. COMM Port Testing

The serial ports can be tested for correct connection and output in the **COMM** menu. This test sends a string of 256 'w' characters to the selected COM port. While the test is running, the red LED on the rear panel of the analyzer should flicker.

To initiate the test press, access the COMMUNICATIONS Menu, then press:

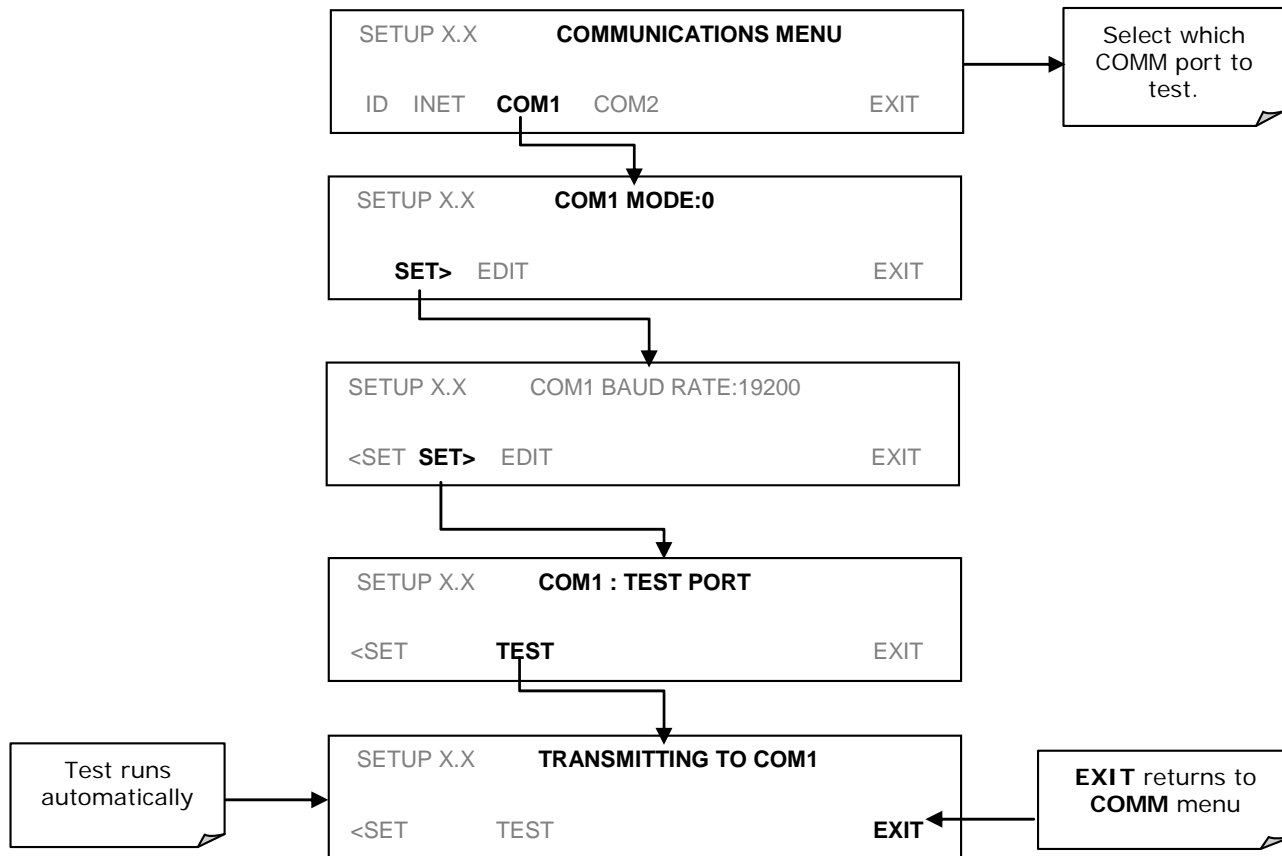

Figure 6-2: COMM – COM1 Test Port

### 6.3. RS-232

The **RS232** and **COM2** communications (COMM) ports operate on the RS-232 protocol (default configuration). Possible configurations for these two COMM ports are summarized as follows:

- RS232 port can also be configured to operate in single or RS-232 Multidrop mode (Option 62); refer to Section 3.3.1.7.
- COM2 port can be left in its default configuration for standard RS-232 operation including multidrop, or it can be reconfigured for half-duplex RS-485 operation (please contact the factory for this configuration).

Note that when the rear panel **COM2** port is in use, the rear panel USB port cannot be used. (Alternatively, when the USB port is enabled, **COM2** port cannot be used)

To configure the analyzer’s communication ports, use the SETUP>MORE>COMM menu. Refer to Section 5.7 for initial setup, and to Section 6.2 for additional configuration information.

## 6.4. Ethernet

When using the Ethernet interface, the analyzer can be connected to any standard 10BaseT or 100BaseT Ethernet network via low-cost network hubs, switches or routers. The interface operates as a standard TCP/IP device on port 3000. This allows a remote computer to connect through the network to the analyzer using APICOM, terminal emulators or other programs.

The Ethernet cable connector on the rear panel has two LEDs indicating the Ethernet's current operating status.

**Table 6-2: Ethernet Status Indicators**

LED	FUNCTION
amber (link)	On when connection to the LAN is valid.
green (activity)	Flickers during any activity on the LAN.

The analyzer is shipped with DHCP enabled by default. This allows the instrument to be connected to a network or router with a DHCP server. The instrument will automatically be assigned an IP address by the DHCP server (Section 6.4.2).

### 6.4.1. Configuring Ethernet Communication Manually (Static IP Address)

1. Connect a cable from the analyzer's Ethernet port to a Local Area Network (LAN) or Internet port.
2. From the analyzer's front panel touchscreen, access the Communications Menu (SETUP>MORE>COMM).
3. Follow the setup sequence as shown in Figure 6-3, and edit the Instrument and Gateway IP addresses and Subnet Mask to the desired settings.
4. From the computer, enter the same information through an application such as HyperTerminal.





Table 6-3 shows the default Ethernet configuration settings.

**Table 6-3: LAN/Internet Default Configuration Properties**

PROPERTY	DEFAULT STATE	DESCRIPTION
DHCP	ON	This displays whether the DHCP is turned ON or OFF. Press EDIT and toggle ON for automatic configuration after first consulting network administrator. (
INSTRUMENT IP ADDRESS		This string of four packets of 1 to 3 numbers each (e.g. 192.168.76.55.) is the address of the analyzer itself.
GATEWAY IP ADDRESS	0.0.0.0	Can only be edited when DHCP is set to OFF. A string of numbers very similar to the Instrument IP address (e.g. 192.168.76.1.) that is the address of the computer used by your LAN to access the Internet.
SUBNET MASK	0.0.0.0	Can only be edited when DHCP is set to OFF. Also a string of four packets of 1 to 3 numbers each (e.g. 255.255.252.0) that identifies the LAN to which the device is connected. All addressable devices and computers on a LAN must have the same subnet mask. Any transmissions sent to devices with different subnets are assumed to be outside of the LAN and are routed through the gateway computer onto the Internet.
TCP PORT <sup>1</sup>	3000	This number defines the terminal control port by which the instrument is addressed by terminal emulation software, such as Internet or Teledyne Analytical Instruments’s APICOM.
HOST NAME	6200T	The name by which your analyzer will appear when addressed from other computers on the LAN or via the Internet. To change, see Section 6.4.2.1.

<sup>1</sup> Do not change the setting for this property unless instructed to by Teledyne Analytical Instruments’s Customer Service personnel.

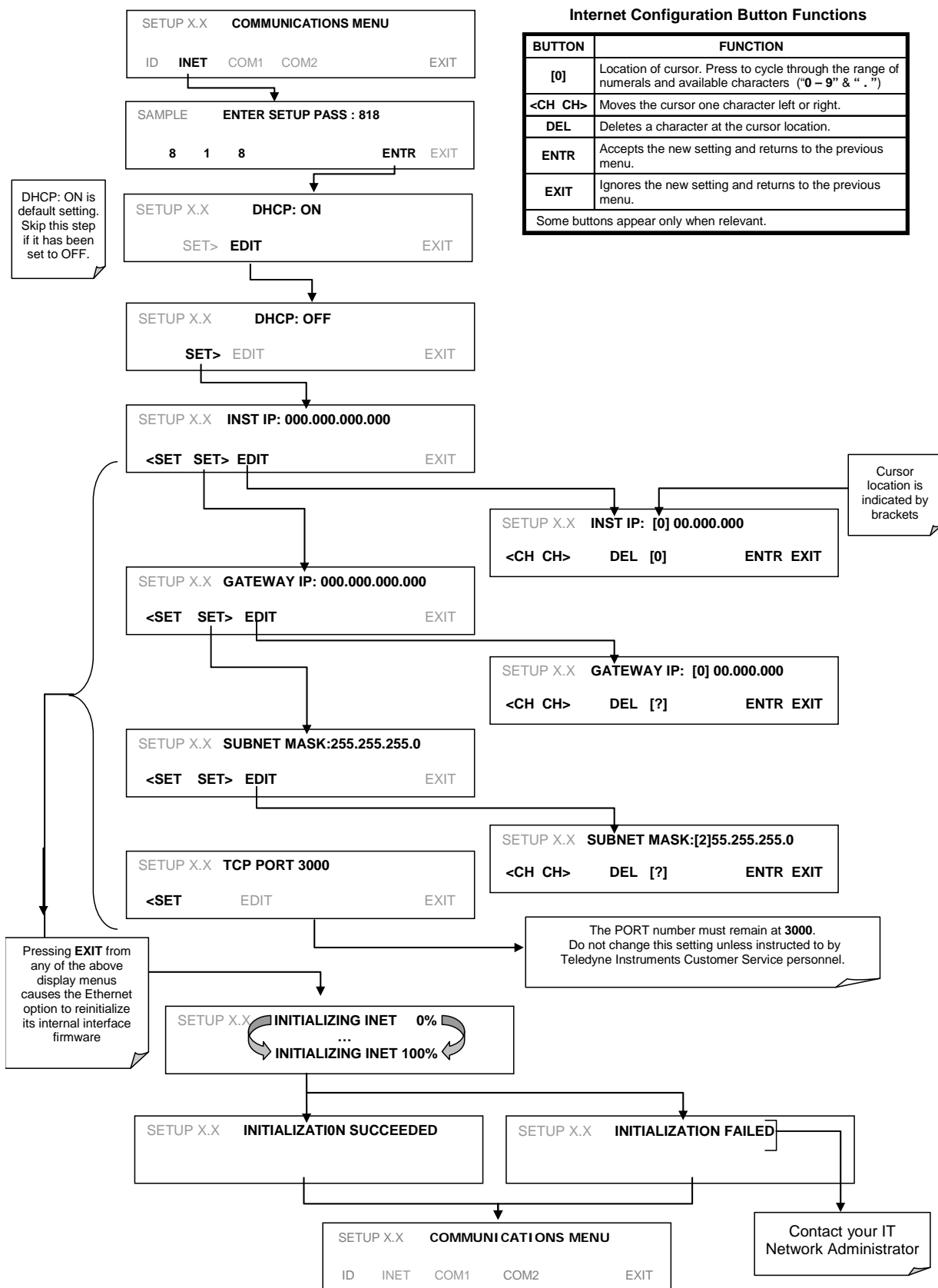

Figure 6-3: COMM – LAN / Internet Manual Configuration



### 6.4.2. Configuring Ethernet Communication Using Dynamic Host Configuration Protocol (DHCP)

1. Consult with your network administrator to affirm that your network server is running DHCP.
2. Access the Communications Menu(SETUP>MORE>COMM .
3. Follow the setup sequence as shown in
4. Figure 6-4.

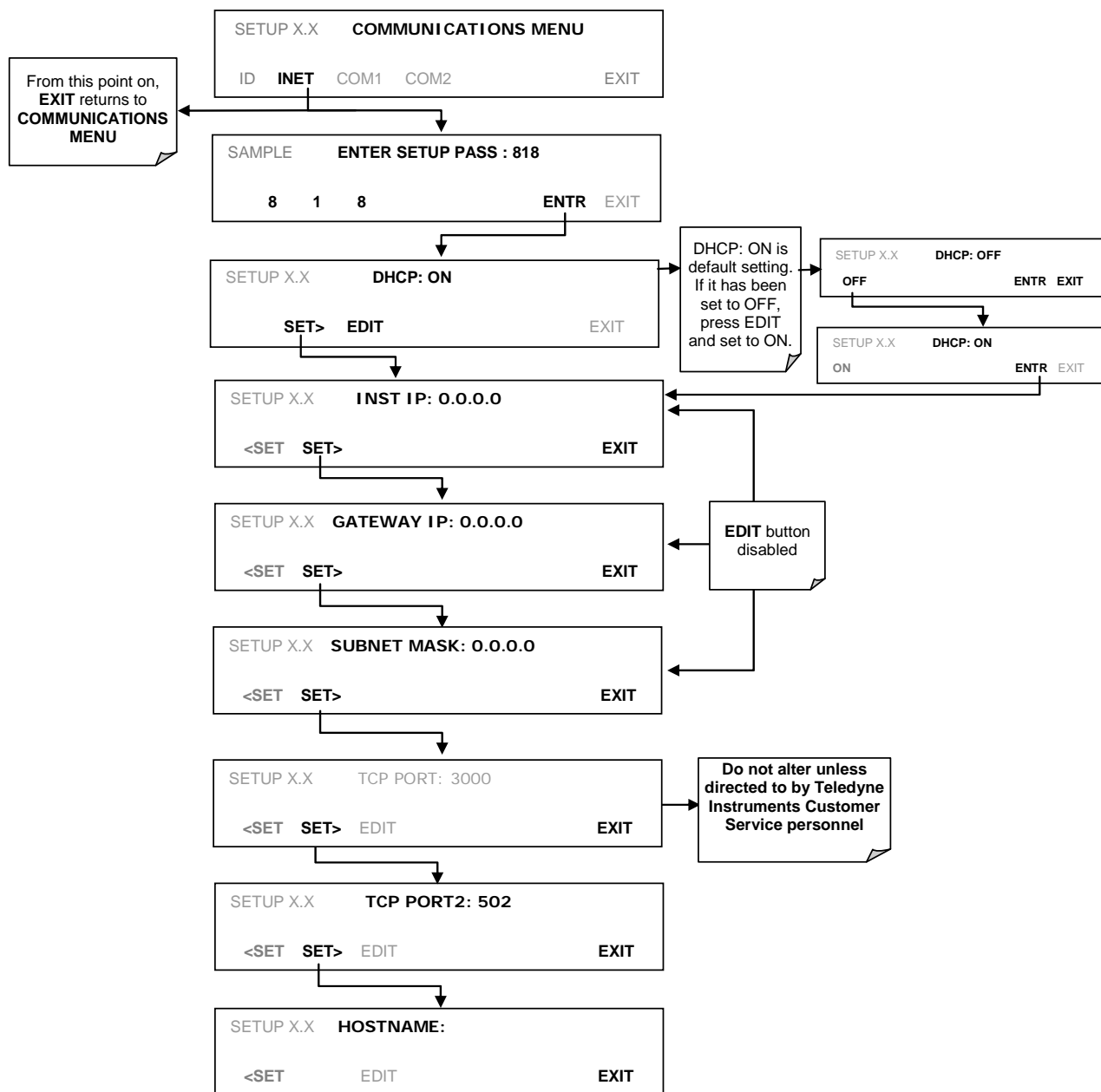

Figure 6-4: COMM – LAN / Internet Automatic Configuration

### 6.4.2.1. Changing the Analyzer’s HOSTNAME

The **HOSTNAME** is the name by which the analyzer appears on your network. To change this name (particularly if you have more than one 6200T analyzer on your network), access the **COMMUNICATIONS**, then press:

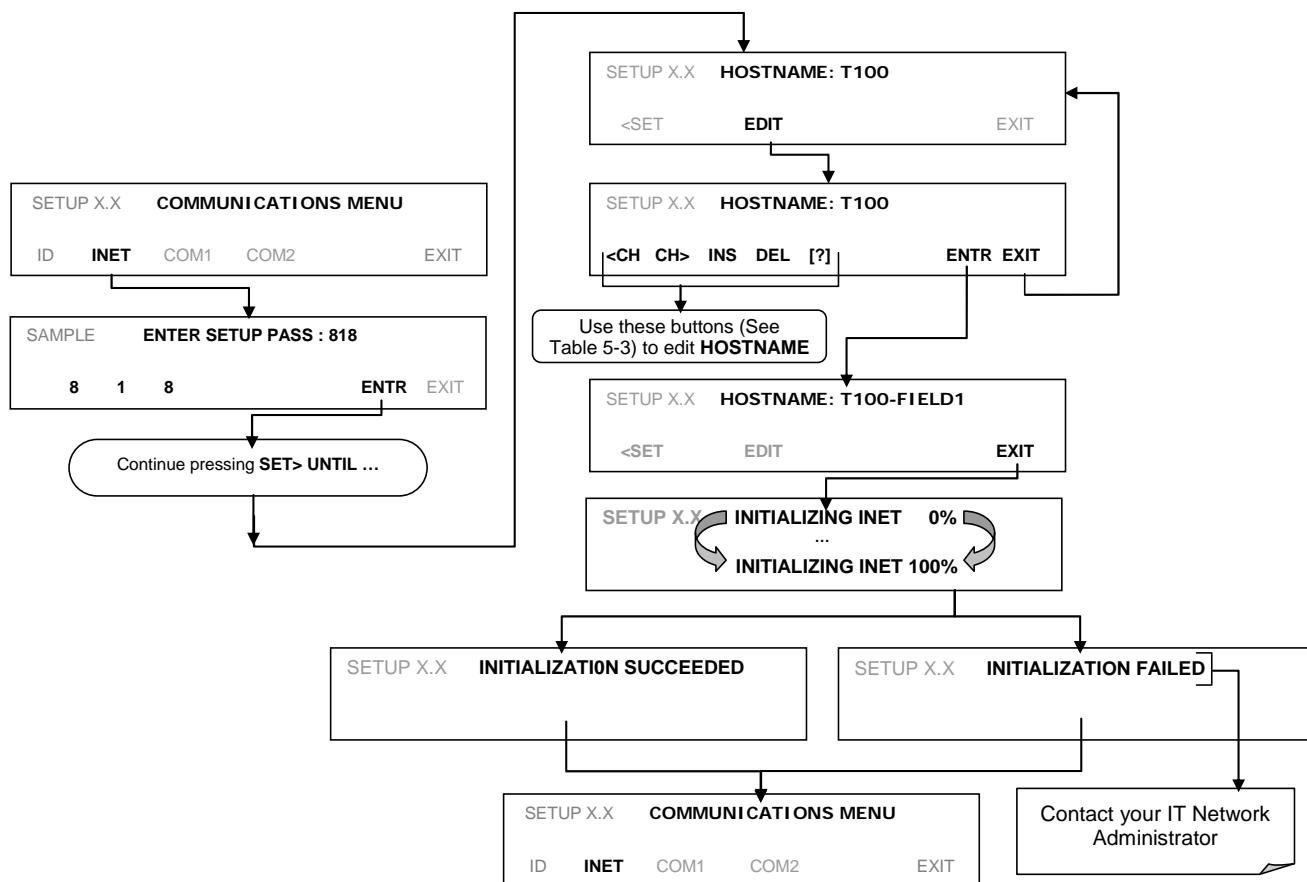

Figure 6-5: COMM – Change Hostname

Table 6-4: Hostname Editing Button Functions

Button	Function
<CH	Moves the cursor one character to the left.
CH>	Moves the cursor one character to the right.
INS	Inserts a character before the cursor location.
DEL	Deletes a character at the cursor location.
[?]	Press this button to cycle through the range of numerals and characters available for insertion.: 0-9, A-Z, space ' ~ ! © # \$ % ^ & * ( ) - _ = + [ ] { } < > \   ; : , . / ?
ENTR	Accepts the new setting and returns to the previous menu.
EXIT	Ignores the new setting and returns to the previous menu.

Buttons only appear when applicable.



### 6.4.3. USB Port

Using the USB port disallows use of the rear panel COM2 port. USB configuration requires matching the baud rates of the instrument and the PC to which it is connected. To view or change the instrument baud rate:

1. Go to SETUP>MORE>COMM>COM2 menu.
2. Press the SET> button until "COM2 BAUD RATE:xxxxx" appears in the Param field of the instrument display. (Figure 6-1 shows the menu sequence).
3. Check that the baud rate of the instrument matches the baud rate of your PC (if needed change either one to match the other).
4. Press the ENTR button to accept any changes.

**This page intentionally left blank.**





## 7. DATA ACQUISITION SYSTEM (DAS) AND APICOM

The 6200T analyzer contains a flexible and powerful, internal data acquisition system (DAS) that enables the analyzer to store concentration and calibration data as well as a host of diagnostic parameters.

For information on configuring and using the DAS, please see the DAS Manual (available separately).

APICOM is an easy-to-use, yet powerful interface program that allows a user to access and control any of Teledyne Analytical Instruments's main line of ambient and stack-gas instruments from a remote connection through direct cable, modem or Ethernet.

For more information on APICOM, please contact the factory and refer to the APICOM Manual (available separately).





**This page intentionally left blank.**

## 8. REMOTE OPERATION OF THE ANALYZER

This section provides information needed when using external digital and serial I/O for remote operation. It also provides references to communications-related manuals.

### 8.1. Remote Operation Using the External Digital I/O

#### 8.1.1. Status Outputs

The status outputs report analyzer conditions via optically isolated NPN transistors, which sink up to 50 mA of DC current. These outputs can interface with devices that accept logic-level digital inputs, such as programmable logic controllers (PLC's). Each Status bit is an open collector output that can withstand up to 40 VDC. All of the emitters of these transistors are tied together and available at D.

#### ATTENTION

#### COULD DAMAGE INSTRUMENT AND VOID WARRANTY

Most PLC's have internal provisions for limiting the current that the input will draw from an external device. When connecting to a unit that does not have this feature, an external dropping resistor must be used to limit the current through the transistor output to less than 50 mA. At 50 mA, the transistor will drop approximately 1.2V from its collector to emitter.

The status outputs are accessed through a 12 pin connector on the analyzer's rear panel labeled STATUS (refer to Figure 3-4). The function of each pin is defined in Table 8-1.

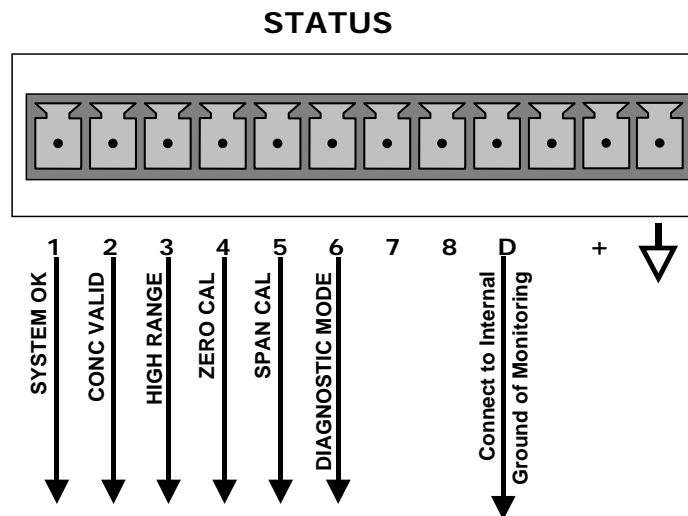



Figure 8-1: Status Output Connector



Table 8-1: Status Output Pin Assignments

CONNECTOR PIN	STATUS	CONDITION (ON=CONDUCTING)
1	System Ok	ON if no faults are present.
2	Conc Valid	ON if concentration measurement is valid, OFF when invalid.
3	High Range	ON if unit is in high range of any AUTO range mode.
4	Zero Cal	ON whenever the instrument is in ZERO calibration mode.
5	Span Cal	ON whenever the instrument is in SPAN calibration mode.
6	Diag Mode	ON whenever the instrument is in DIAGNOSTIC mode.
7-8		Unused
D	Emitter Bus	The emitters of the transistors on pins 1-8 are bussed together. For most applications, this pin should be connected to the circuit ground of the receiving device.
+	DC Power	+ 5 VDC source, 30 mA maximum (combined rating with Control Inputs)
	Digital Ground	The ground from the analyzer's internal, 5/±15 VDC power supply.

### 8.1.2. Control Inputs

Control inputs allow the user to remotely initiate ZERO and SPAN calibration modes are provided through a 10-pin connector labeled CONTROL IN on the analyzer's rear panel. These are opto-isolated, digital inputs that are activated when a 5 VDC signal from the "U" pin is connected to the respective input pin.

Table 8-2: Control Input Pin Assignments

INPUT	STATUS	CONDITION WHEN ENABLED
A	External Zero Cal	Zero calibration mode is activated. The mode field of the display will read ZERO CAL R.
B	External Span Cal	Span calibration mode is activated. The mode field of the display will read SPAN CAL R.
C		Unused
D		Unused
E		Unused
F		Unused
	Digital Ground	Provided to ground an external device (e.g., recorder).
U	DC Power for Input Pull Ups	Input for +5 VDC required to activate inputs A - F. This voltage can be taken from an external source or from the "+" pin.
+	Internal +5V Supply	Internal source of +5V which can be used to activate inputs when connected to pin U.

There are two methods to activate control inputs. The internal +5V available from the "+" pin is the most convenient method (Figure 8-2). However, to ensure that these inputs are truly isolated, a separate, external 5 VDC power supply should be used (Figure 8-3).

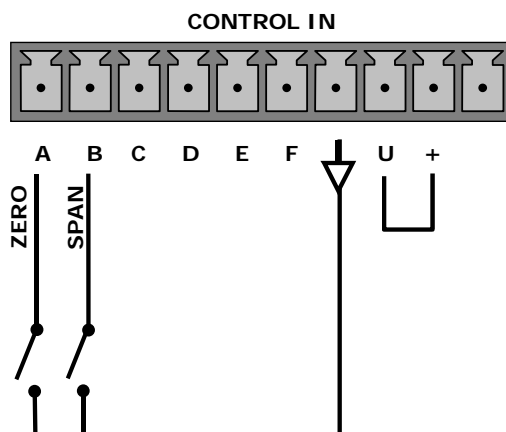

Figure 8-2: Control Inputs with Local 5 V Power Supply

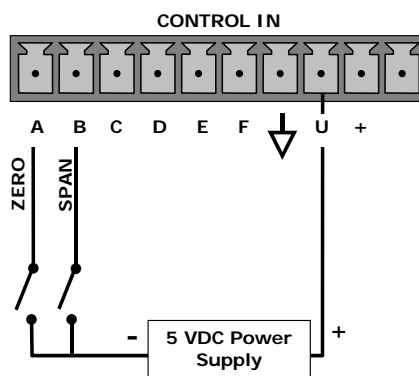

Figure 8-3: Control Inputs with External 5 V Power Supply

## 8.2. Remote Operation Using the External Serial I/O

This section describes the serial communications protocol which is available when “TAI Protocol” is disabled on the communications port.

### 8.2.1. Terminal Operating Modes

The 6200T can be remotely configured, calibrated or queried for stored data through the serial ports. As terminals and computers use different communication schemes, the analyzer supports two communication modes specifically designed to interface with these two types of devices.

**Computer mode** is used when the analyzer is connected to a computer with a dedicated interface program such as APICOM. More information regarding APICOM can be found in later in this section.

**Interactive mode** is used with a terminal emulation programs such as HyperTerminal or a “dumb” computer terminal. The commands that are used to operate the analyzer in this mode are listed in Table 8-3.



## 8.2.2. Help Commands in Terminal Mode

**Table 8-3: Terminal Mode Software Commands**

Command	Function
Control-T	Switches the analyzer to terminal mode (echo, edit). If mode flags 1 & 2 are OFF, the interface can be used in interactive mode with a terminal emulation program.
Control-C	Switches the analyzer to computer mode (no echo, no edit).
CR (carriage return)	A carriage return is required after each command line is typed into the terminal/computer. The command will not be sent to the analyzer to be executed until this is done. On personal computers, this is achieved by pressing the ENTER button.
BS (backspace)	Erases one character to the left of the cursor location.
ESC (escape)	Erases the entire command line.
? [ID] CR	This command prints a complete list of available commands along with the definitions of their functionality to the display device of the terminal or computer being used. The ID number of the analyzer is only necessary if multiple analyzers are on the same communications line, such as the multi-drop setup.
Control-C	Pauses the listing of commands.
Control-P	Restarts the listing of commands.

## 8.2.3. Command Syntax

Commands are not case-sensitive and all arguments within one command (i.e. ID numbers, keywords, data values, etc.) must be separated with a space character.

All Commands follow the syntax:

**X [ID] COMMAND <CR>**

Where:

**X** is the command type (one letter) that defines the type of command. Allowed designators are listed in Table 6-25 and Appendix A-6.

**[ID]** is the analyzer identification number (refer to Section 6.10.1.). Example: the Command “? 200” followed by a carriage return would print the list of available commands for the revision of software currently installed in the instrument assigned ID Number 200.

**COMMAND** is the command designator: This string is the name of the command being issued (LIST, ABORT, NAME, EXIT, etc.). Some commands may have additional arguments that define how the command is to be executed. **<CR>** is a carriage return. All commands must be terminated by a carriage return (usually achieved by pressing the ENTER button on a computer).

**Table 8-4: Command Types**

COMMAND	COMMAND TYPE
C	Calibration
D	Diagnostic
L	Logon
T	Test measurement
V	Variable
W	Warning

## 8.2.4. Data Types

Data types consist of integers, hexadecimal integers, floating-point numbers, Boolean expressions and text strings.

**Integer** data are used to indicate integral quantities such as a number of records, a filter length, etc. They consist of an optional plus or minus sign, followed by one or more digits. For example, *+1*, *-12*, *123* are all valid integers.

**Hexadecimal** integer data are used for the same purposes as integers. They consist of the two characters "0x," followed by one or more hexadecimal digits (0-9, A-F, a-f), which is the 'C' programming language convention. No plus or minus sign is permitted. For example, *0x1*, *0x12*, *0x1234abcd* are all valid hexadecimal integers.

**Floating-point numbers** are used to specify continuously variable values such as temperature set points, time intervals, warning limits, voltages, etc. They consist of an optional plus or minus sign, followed by zero or more digits, an optional decimal point, and zero or more digits. (At least one digit must appear before or after the decimal point.) Scientific notation is not permitted. For example, *+1.0*, *1234.5678*, *-0.1*, *1* are all valid floating-point numbers.

**Boolean expressions** are used to specify the value of variables or I/O signals that may assume only two values. They are denoted by the keywords *ON* and *OFF*.

**Text strings** are used to represent data that cannot be easily represented by other data types, such as data channel names, which may contain letters and numbers. They consist of a quotation mark, followed by one or more printable characters, including spaces, letters, numbers, and symbols, and a final quotation mark. For example, *"a"*, *"1"*, *"123abc"*, and *"()[<>"* are all valid text strings. It is not possible to include a quotation mark character within a text string.

Some commands allow you to access variables, messages, and other items, such as DAS data channels, by name. When using these commands, you must type the entire name of the item; you cannot abbreviate any names.

## 8.2.5. Status Reporting

Reporting of status messages as an audit trail is one of the three principal uses for the RS-232 interface (the other two being the command line interface for controlling the instrument and the download of data in electronic format). You can effectively disable the reporting feature by setting the interface to quiet mode (refer to Section **Error! Reference source not found.** and Table 6-1.

Status reports include DAS data (when reporting is enabled), warning messages, calibration and diagnostic status messages. Refer to Appendix A-3 for a list of the possible messages, and this section for information on controlling the instrument through the RS-232 interface.

### 8.2.5.1. General Message Format

All messages from the instrument (including those in response to a command line request) are in the format:

**X DDD:HH:MM [Id] MESSAGE<CRLF>**

Where:

**X** is a command type designator, a single character indicating the message type.



- DDD:HH:MM** is the time stamp, the date and time when the message was issued. It consists of the Day-of-year (DDD) as a number from 1 to 366, the hour of the day (HH) as a number from 00 to 23, and the minute (MM) as a number from 00 to 59.
- [ID]** is the analyzer ID, a number with 1 to 4 digits.
- MESSAGE** is the message content that may contain warning messages, test measurements, DAS reports, variable values, etc.
- <CRLF>** is a carriage return / line feed pair, which terminates the message.

The uniform nature of the output messages makes it easy for a host computer to parse them into an easy structure. Keep in mind that the front panel display does not give any information on the time a message was issued, hence it is useful to log such messages for trouble-shooting and reference purposes. Terminal emulation programs such as HyperTerminal can capture these messages to text files for later review.

### 8.3. Remote Access by Modem

The 6200T can be connected to a modem for remote access. This requires a cable between the analyzer's COM port and the modem, typically a DB-9F to DB-25M cable (available from Teledyne Analytical Instruments with P/N WR0000024).

Once the cable has been connected, check to ensure that the DTE-DCE is in the correct position (refer to Section 6.1). Also ensure that the 6200T COM port is set for a baud rate that is compatible with the modem, which needs to operate with an 8-bit word length with one stop bit.

The first step is to turn on the **MODEM ENABLE** communication mode (Mode 64, Section **Error! Reference source not found.**). Once this is completed, the appropriate setup command line for your modem can be entered into the analyzer. The default setting for this feature is:

**AT Y0 &D0 &H0 &I0 S0=2 &B0 &N6 &M0 E0 Q1 &W0**

This string can be altered to match your modem's initialization and can be up to 100 characters long.

To change this setting, access the COMMUNICATIONS (COMM) Menu by pressing SETUP and then MORE, then select the COM port to which the modem is connected (COM1 or COM2)



Move to the Modem Initit screen by pressing SET twice.

Press EDIT to advance to the next screen where you can enter or edit the initialization command.

The following buttons are available for use in editing the command:

- CH</CH> Moves the brackets indicating the currently editable digit.
- INS Inserts a character before the cursor loction.
- DEL Deletes the character at the cursor location.
- [A] Cycles through the available character set.
- ENTR Accepts the new string and returns to the previous menu.
- EXIT Ignores the input and returns to the previous menu.





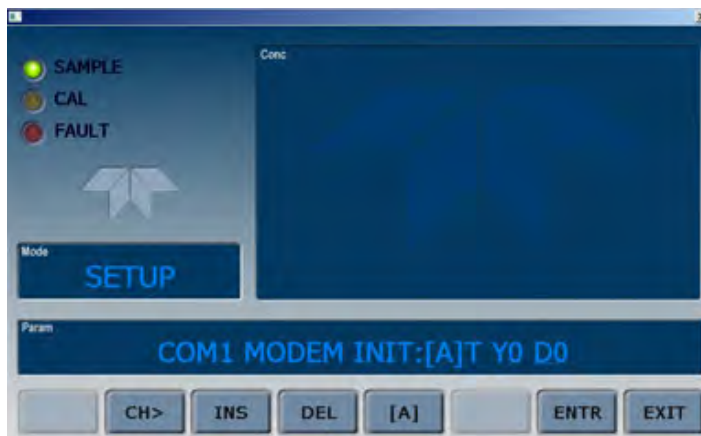

To initialize the modem, access the COMMUNICATIONS Menu), then press COM 1(or COM2) and then EDIT. Press the NEXT button until the COM1 (or COM2) ENABLE MODEM screen appears.

Use the ON/OFF button to switch the modem on or off.

## 8.4. COM Port Password Security

In order to provide security for remote access of the 6200T, a LOGON feature can be enabled to require a password before the instrument will accept commands. This is done by turning on the **SECURITY MODE** (refer to Section 5.5). Once the **SECURITY MODE** is enabled, the following items apply.

- A password is required before the port will respond or pass on commands.
- If the port is inactive for one hour, it will automatically logoff, which can also be achieved with the LOGOFF command.
- Three unsuccessful attempts to log on with an incorrect password will cause subsequent logins to be disabled for 1 hour, even if the correct password is used.
- If not logged on, the only active command is the '?' request for the help screen.
- The following messages will be returned at logon:

- LOGON SUCCESSFUL - Correct password given
- LOGON FAILED - Password not given or incorrect
- LOGOFF SUCCESSFUL - Connection terminated successfully

To log on to the 6200T analyzer with **SECURITY MODE** feature enabled, type:

```
LOGON 940331
```

940331 is the default password. To change the default password, use the variable RS-232\_PASS issued as follows:

```
V RS-232_PASS=NNNNNN
```

Where N is any numeral between 0 and 9.

## 8.5. Additional Communications Documentation

**Table 8-5: Serial Interface Documents**

Interface / Tool	Document Title	Part Number
APICOM	APICOM User Manual	058130000
DAS Manual	Detailed description of the DAS	028370000



## 8.6. Additional Calibration Details

### 8.6.1. Calibration with Remote Contact Closures

Contact closures for controlling calibration and calibration checks are located on the rear panel **CONTROL IN** connector. Instructions for setup and use of these contacts can be found in Section 8.1.2.

When the appropriate contacts are closed for at least 5 seconds, the instrument switches into zero, low span or high span mode and the internal zero/span valves will be automatically switched to the appropriate configuration. The remote calibration contact closures may be activated in any order. It is recommended that contact closures remain closed for at least 10 minutes to establish a reliable reading; the instrument will stay in the selected mode for as long as the contacts remain closed.

If contact closures are used in conjunction with the analyzer's AutoCal (refer to Section 8.7) feature and the AutoCal attribute **CALIBRATE** is enabled, the 6200T will not re-calibrate the analyzer until the contact is opened. At this point, the new calibration values will be recorded before the instrument returns to SAMPLE mode.

If the AutoCal attribute **CALIBRATE** is disabled, the instrument will return to SAMPLE mode, leaving the instrument's internal calibration variables unchanged.

## 8.7. Automatic Calibration (AutoCal)

### NOTE

**Auto Calibration is only available when the TAI PROTOCOL is OFF**

### 8.7.1. Switching TAI Protocol ON/OFF

To engage the autocal function, the TAI PROTOCOL communication mode must be switched off. Perform the following steps for both COM1 and COM2:

- Enter the COMM function, from the main screen display press SETUP, then MORE and then COM.
- Select COM1 or COM2.

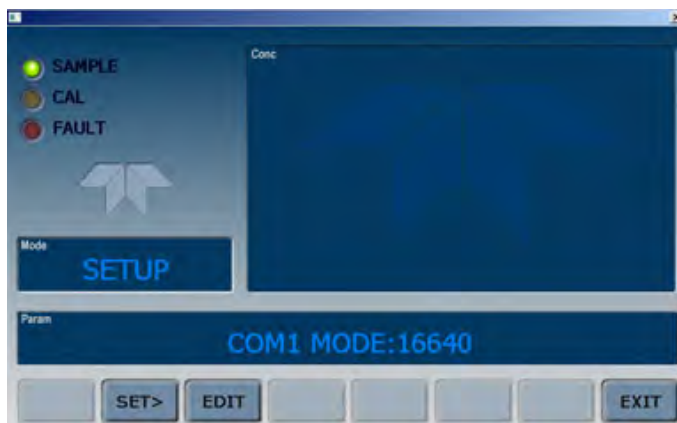

- Press EDIT and then NEXT repeatedly until COM1(2) TAI PROTOCOL:ON appears on the display.



- If TAI PROTOCOL is ON, press the ON button to turn it OFF. Then press ENTR to save the change.

### 8.7.2. AutoCal Modes

The AutoCal system allows unattended, periodic operation of the zero/span valve options by using the analyzer's internal time of day clock. AutoCal operates by executing user-defined sequences to initiate the various calibration modes of the analyzer and to open and close valves appropriately. It is possible to program and run up to three separate sequences (**SEQ1**, **SEQ2** and **SEQ3**). Each sequence can operate in one of three modes or be disabled.

**Table 8-6: AutoCal Modes**

MODE	ACTION
DISABLED	Disables the sequence
ZERO	Causes the sequence to perform a zero calibration or check
ZERO-SPAN	Causes the sequence to perform a zero and span concentration calibration or check
SPAN	Causes the sequence to perform a span concentration calibration or check

Each mode has seven setup parameters (Table 8-7) that control operational details of the sequence.



Table 8-7: AutoCal Attribute Setup Parameters

PARAMETER	ACTION
Timer Enabled	Turns on the Sequence timer
Starting Date	Sequence will operate on Starting Date
Starting Time	Sequence will operate at Starting Time <sup>1,2</sup>
Delta Days	Number of days to skip between each sequence
Delta Time	Incremental delay on each Delta Day that the sequence starts.
Duration	Duration of the sequence in minutes
Calibrate	Enable to do dynamic zero/span calibration, disable to do a cal check only. This must be set to OFF for units used in US EPA applications and with IZS option installed.

<sup>1</sup> The programmed STARTING\_TIME must be a minimum of 5 minutes later than the real time clock (refer to Section 6.6 for setting real time clock).

<sup>2</sup> Avoid setting two or more sequences at the same time of the day. Any new sequence which is initiated whether from a timer, the COMM ports, or the contact closure inputs will override any sequence which is in progress.

## Note

If at any time an inapplicable entry is selected (Example: Delta Days > 367) the ENTR button will disappear from the display.

## Note

The CALIBRATE attribute must always be set to OFF for analyzers used in US EPA controlled applications that have IZS option installed.

Calibration of instruments used in US EPA related applications should only be performed using external sources of zero air and span gas with an accuracy traceable to EPA or NIST standards and supplied through the analyzer's sample port (refer to Section Error! Reference source not found.).

The following example sets Sequence 2 to carry out a zero-span calibration every other day starting at 01:00 on September 4, 2002, lasting 15 minutes. This sequence will start 0.5 hours later each day.

Table 8-8: Example Auto-Cal Sequence

MODE / ATTRIBUTE	VALUE	COMMENT
SEQUENCE	2	Define Sequence #2
MODE	ZERO-SPAN	Select Zero and Span Mode
TIMER ENABLE	ON	Enable the timer
STARTING DATE	Sept. 4, 2002	Start after Sept 4, 2002
STARTING TIME	01:00	First Span starts at 01:00
DELTA DAYS	2	Do Sequence #2 every other day
DELTA TIME	00:30	Do Sequence #2 0.5 h later each day
DURATION	15.0	Operate Span valve for 15 min
CALIBRATE	ON	The instrument will re-set the slope and offset values for the SO <sub>2</sub> channel at the end of the AutoCal sequence

To program the sample sequence shown in Table 8-8:

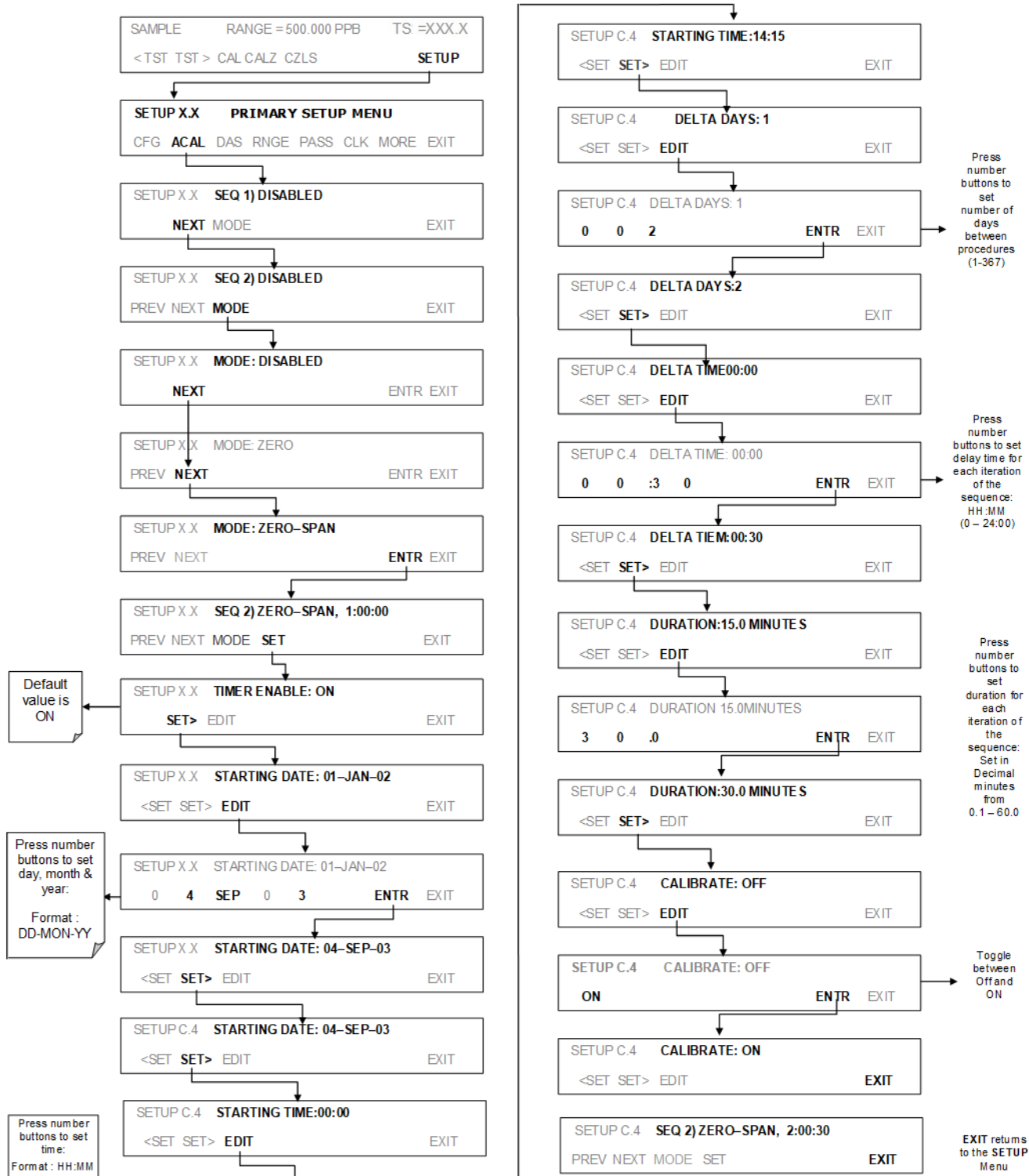

Figure 8-4: AUTO CAL – User Defined Sequence



With dynamic calibration turned on, the state of the internal setup variables **DYN\_SPAN** and **DYN\_ZERO** is set to **ON** and the instrument will reset the slope and offset values for the SO<sub>2</sub> response each time the AutoCal program runs. This continuous re-adjustment of calibration parameters can often mask subtle fault conditions in the analyzer. It is recommended that, if dynamic calibration is enabled, the analyzer's test functions, slope and offset values be checked frequently to assure high quality and accurate data from the instrument.

## 8.8. Calibration Quality

After completing one of the calibration procedures described above, it is important to evaluate the analyzer's calibration **SLOPE** and **OFFSET** parameters. These values describe the linear response curve of the analyzer. The values for these terms, both individually and relative to each other, indicate the quality of the calibration. To perform this quality evaluation, you will need to record the values of both test functions (refer to Section 4.1.1), all of which are automatically stored in the DAS channel **CALDAT** for data analysis, documentation and archival.

Ensure that these parameters are within the limits listed in the following Table.

**Table 8-9: Calibration Data Quality Evaluation**

<b>FUNCTION</b>	<b>MINIMUM VALUE</b>	<b>OPTIMUM VALUE</b>	<b>MAXIMUM VALUE</b>
<b>SLOPE</b>	0.700	1.000	1.300
<b>OFFS</b>	50.0 mV	n/a	250.0 mV

These values should not be significantly different from the values recorded on the Teledyne Analytical Instruments *Final Test and Validation Data* sheet that was shipped with your instrument. If they are, refer to troubleshooting in Section 10.

**PART III**  
**MAINTENANCE AND SERVICE**





**This page intentionally left blank.**

## 9. INSTRUMENT MAINTENANCE

Predictive diagnostic functions including data acquisition, failure warnings and alarms built into the analyzer allow the user to determine when repairs are necessary. However, preventive maintenance procedures that, when performed regularly, will help to ensure that the analyzer continues to operate accurately and reliably over its lifetime. Maintenance procedures are covered in this section, followed by troubleshooting and service procedures in Section 10 of this manual.

**Note:** To support your understanding of the technical details of maintenance, Section 11, *Principles of Operation*, provides information about how the instrument works.

### IMPORTANT

#### IMPACT ON READINGS OR DATA

A span and zero calibration check must be performed following some of the maintenance procedures listed below. Refer to Section 8.6.



### WARNING! RISK OF ELECTRICAL SHOCK

Disconnect power before performing any operations that require entry into the interior of the analyzer.



### CAUTION

The operations outlined in this section must be performed by qualified maintenance personnel only.

### Note

The front panel of the analyzer is hinged at the bottom and may be opened by two fasteners located in the upper right and left corners to gain access to various components that are either mounted on the panel itself or located near the front of the instrument (such as the particulate filter).



## 9.1. Maintenance Schedule

Table 9-1 is the recommended maintenance schedule for the 6200T. Please note that in certain environments with high levels of dust, humidity or pollutant levels some maintenance procedures may need to be performed more often than shown.

**Table 9-1: 6200T Preventive Maintenance Schedule**

ITEM	ACTION	FREQUENCY	CAL CHECK	MANUAL SECTION
<sup>1</sup> Particulate filter	Change particle filter	Weekly	No	9.3.1
Verify test functions	Review and evaluate	Weekly	No	9.2
Zero/span check	Evaluate offset and slope	Weekly	--	Error! Reference source not found., Error! Reference source not found., 8.8
<sup>1</sup> Zero/span calibration	Zero and span calibration	Every 3 months	--	Error! Reference source not found., Error! Reference source not found., Error! Reference source not found., 8.7
<sup>1</sup> TS and zero air scrubbers	Exchange chemical	Every 3 months	No	9.3.3
<sup>1</sup> Perform flow check	Check Flow	Every 6 Months	No	9.3.7
Internal IZS Permeation Tube	Replace	Annually	YES	9.3.2
Perform pneumatic leak check	Verify Leak Tight	Annually or after repairs involving pneumatics	Yes	9.3.6
<sup>2</sup> Pump diaphragm	Replace	Annually	Yes	Refer to diaphragm kit instructions
Calibrate UV Lamp Output	Perform LAMP CAL	Prior to zero/span calibration or PMT hardware calibration	--	5.9.6 & 10.6.1.5
<sup>3</sup> PMT sensor hardware calibration	Low-level hardware calibration	On PMT/ preamp changes if $0.7 < \text{SLOPE}$ or $\text{SLOPE} > 1.3$	Yes	10.6.1.8
<sup>1</sup> Sample chamber optics	Clean chamber, windows and filters	As necessary	Yes	10.6.1
<sup>1</sup> Critical flow orifice & sintered filters	Replace	As necessary	Yes	9.3.4
<sup>1</sup> These Items are required to maintain full warranty; all other items are strongly recommended. <sup>2</sup> A pump rebuild kit is available from Teledyne Analytical Instruments's Customer Service including all instructions and required parts (refer to Appendix B for part numbers). <sup>3</sup> Replace desiccant bags each time the inspection plate for the sensor assembly is removed.				

## 9.2. Predictive Diagnostics

The analyzer's test functions can be used to predict failures by looking at trends in their values (refer to Table 9-2) and by comparing them values recorded for them at the factory and recorded on the *6200T Final Test and Validation Data Form* (Teledyne Analytical Instruments P/N 04551) that was shipped with your analyzer.

A convenient way to record and track changes to these parameters is the internal data acquisition system (DAS). Also, APICOM control software can be used to download and record these data for review even from remote locations (Section **Error! Reference source not found.** discusses APICOM).

**Table 9-2: Predictive Uses for Test Functions**

TEST FUNCTION	DAS FUNCTION	CONDITION	BEHAVIOR		INTERPRETATION
			EXPECTED	ACTUAL	
PRES	SMPPRS	sample gas	Constant within atmospheric changes	Fluctuating	<ul style="list-style-type: none"> <li>Developing leak in pneumatic system</li> </ul>
				Slowly increasing	<ul style="list-style-type: none"> <li>Flow path is clogging up.               <ul style="list-style-type: none"> <li>Check critical flow orifice &amp; sintered filter.</li> <li>Replace particulate filter</li> </ul> </li> </ul>
				Slowly decreasing	<ul style="list-style-type: none"> <li>Developing leak in pneumatic system to vacuum (developing valve failure)</li> </ul>
DRK PMT	DRKPMT	PMT output when UV Lamp shutter closed	Constant within $\pm 20$ of check-out value	Significantly increasing	<ul style="list-style-type: none"> <li>PMT cooler failure</li> <li>Shutter Failure</li> </ul>
H <sub>2</sub> S concentration	CONC1	At span with IZS option installed	Constant response from day to day	Decreasing over time	<ul style="list-style-type: none"> <li>Change in instrument response</li> <li>Degradation of IZS permeation tube</li> </ul>
		Standard configuration at span	stable for constant concentration	Decreasing over time	<ul style="list-style-type: none"> <li>Drift of instrument response; UV Lamp output is excessively low.</li> </ul>
SAMP FL	SMPFLW	Standard Operation	Stable	Slowly Decreasing	<ul style="list-style-type: none"> <li>Flow path is clogging up.               <ul style="list-style-type: none"> <li>Check critical flow orifice &amp; sintered filter.</li> <li>Replace particulate filter</li> </ul> </li> </ul>
				Fluctuating	<ul style="list-style-type: none"> <li>Leak in gas flow path.</li> </ul>
LAMP RATIO	LAMPR	Standard Operation	Stable and near 100%	Fluctuating or Slowly increasing	<ul style="list-style-type: none"> <li>UV detector wearing out</li> <li>UV source Filter developing pin holes</li> </ul>
				Slowly decreasing	<ul style="list-style-type: none"> <li>UV detector wearing out</li> <li>Opaque oxides building up on UV source Filter</li> <li>UV lamp aging</li> </ul>



## 9.3. Maintenance Procedures

The following procedures need to be performed regularly as part of the standard maintenance of the 6200T.

### 9.3.1. Changing the Sample Particulate Filter

The particulate filter should be inspected often for signs of plugging or excess dirt. It should be replaced according to the service interval in Table 9-1 even without obvious signs of dirt. Filters with 1 and 5  $\mu\text{m}$  pore size can clog up while retaining a clean look. We recommend handling the filter and the wetted surfaces of the filter housing with gloves and tweezers.

**IMPORTANT****IMPACT ON READINGS OR DATA**

**Do not touch any part of the housing, filter element, PTFE retaining ring, glass cover and the O-ring with bare hands, as contamination can negatively impact accuracy of readings..**

To change the filter according to the service interval in Table 9-1:

1. Turn OFF the analyzer to prevent drawing debris into the sample line.
2. Open the analyzer's hinged front panel and unscrew the knurled retaining ring of the filter assembly.

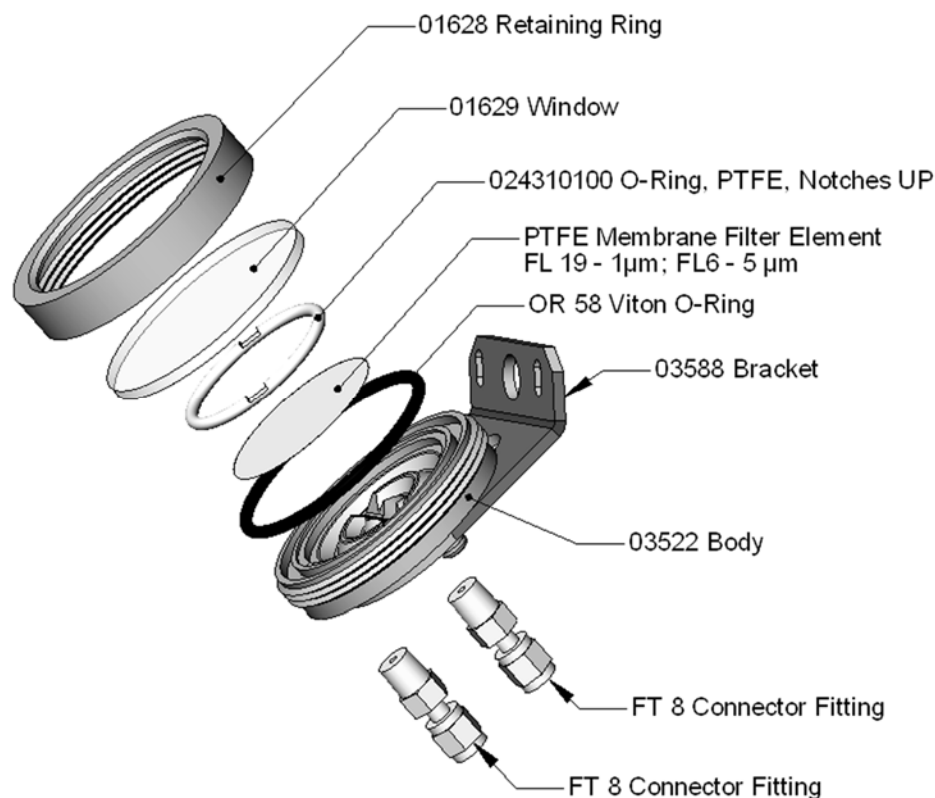

**Figure 9-1: Sample Particulate Filter Assembly**

3. Carefully remove the retaining ring, glass window, PTFE O-ring and filter element.
4. Replace the filter element, carefully centering it in the bottom of the holder.

5. Re-install the PTFE O-ring with the notches facing up, the glass cover, then screw on the hold-down ring and hand-tighten the assembly. Inspect the (visible) seal between the edge of the glass window and the O-ring to assure proper gas tightness.
6. Re-start the analyzer.

### 9.3.2. Changing the IZS Permeation Tube

1. Turn off the analyzer, unplug the power cord and remove the cover.
2. Locate the IZS oven in the rear left of the analyzer.
3. Remove the top layer of insulation if necessary.
4. Unscrew the black aluminum cover of the IZS oven (3 screws) using a medium Phillips-head screw driver. Leave the fittings and tubing connected to the cover.
5. Remove the old permeation tube if necessary and replace it with the new tube. Ensure that the tube is placed into the larger of two holes and that the open permeation end of the tube (Teflon) is facing up.
6. Re-attach the cover with three screws and ensure that the sealing O-ring is properly in place and that the three screws are tightened evenly.
7. Replace the analyzer cover, plug the power cord back in and turn on the analyzer.
8. Carry out an IZS span check to see if the new permeation device works properly. The permeation rate may need several days to stabilize.

#### ATTENTION

---

#### COULD DAMAGE INSTRUMENT AND VOID WARRANTY

**Do not leave instrument turned off for more than 8 hours without removing the permeation tube. Do not ship the instrument without removing the permeation tube. The tube continues to emit gas, even at room temperature and will contaminate the entire instrument.**

---

### 9.3.3. Changing the TS and Zero Air Scrubber Materials

The 6200T has one standard charcoal scrubber on the rear panel of the SO<sub>2</sub> analyzer instrument chassis, and another special charcoal scrubber inside the chassis. The zero calibration (and thus the overall accuracy of the instrument) is dependent on high quality zero air.

The chemicals in the external and internal scrubbers need to be replaced periodically according to Table 9-1 or as needed. This procedure can be carried out while the instrument is running. Ensure that the analyzer is not in either the ZERO or SPAN calibration modes.

**Make sure that the charcoal is replaced at the 3-month interval suggested in the 6400T maintenance schedule. Also be sure not to mix charcoal between the inner and outer scrubber canisters, they are different materials.**

1. Locate the scrubber on the outside rear panel.



2. Remove the old scrubber by disconnecting the 1/4" plastic tubing from the particle filter using 9/16" and 1/2" wrenches.
3. Remove the particle filter from the cartridge using 9/16" wrenches.
4. Unscrew the top of the scrubber canister and discard charcoal contents. Ensure to abide by local laws for discarding these chemicals. The rebuild kit See Section 13.1) comes with a Material and Safety Data Sheet, which contains more information on these chemicals.
5. Refill the scrubber with charcoal at the bottom.
6. Tighten the cap on the scrubber - hand-tight only.
7. Replace the DFU filter, if required, with a new unit and discard the old.
8. Replace the scrubber assembly into its clips on the rear panel.
9. Reconnect the plastic tubing to the fitting of the particle filter.
10. Adjust the scrubber cartridge such that it does not protrude above or below the analyzer in case the instrument is mounted in a rack. If necessary, squeeze the clips for a tighter grip on the cartridge.

### 9.3.4. Changing the Critical Flow Orifice

A critical flow orifice, located on the exhaust manifold maintains the proper flow rate of gas through the 6200T analyzer. Despite the fact this device is protected by sintered stainless steel filters, it can, on occasion, clog, particularly if the instrument is operated without a sample filter or in an environment with very fine, sub-micron particle-size dust.

1. Turn off power to the instrument and vacuum pump.
2. Locate the critical flow orifice on the pressure sensor assembly (called out in Figure 9-2).
3. Disconnect the pneumatic line.
4. Unscrew the NPT fitting.

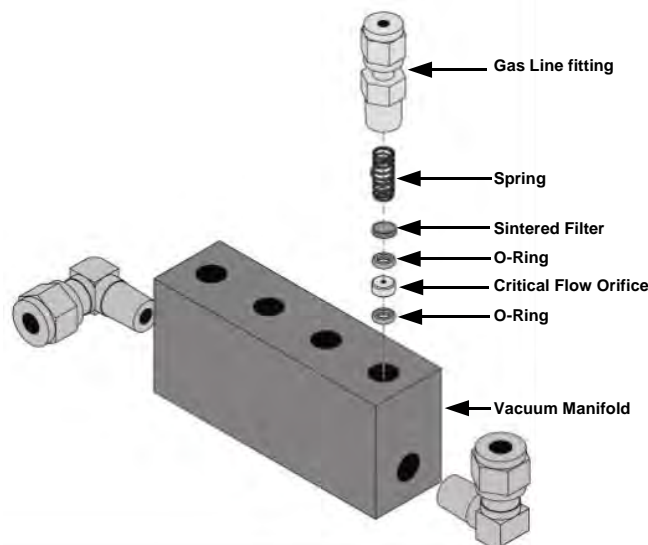

Figure 9-2: Critical Flow Orifice Assembly

5. Take out the components of the assembly: a spring, a sintered filter, two O-rings and the critical flow orifice.
6. You may need to use a scribe or pressure from the vacuum port to get the parts out of the manifold.
7. Discard the two O-rings and the sintered filter.
8. Replace the critical flow orifice.
9. Let the part dry.
10. Re-assemble the parts as shown in Figure 9-2 using a new filter and o-rings.
11. Reinstall the NPT fitting and connect all tubing.
12. Power up the analyzer and allow it to warm up for 60 minutes.
13. Perform a leak check (refer to Section 9.3.6).

### 9.3.5. Checking for Light Leaks

When re-assembled after maintenance, repair or improper operation, the 6200T can develop small leaks around the PMT, allowing stray light from the analyzer surroundings into the PMT housing. To find light leaks, follow the below procedures:



#### CAUTION

**This procedure must be carried out by qualified personnel, as it must be performed while the analyzer is powered up and running and its cover removed.**



#### WARNING RISK OF ELECTRICAL SHOCK

**Some operations need to be carried out with the analyzer open and running. Exercise caution to avoid electrical shocks and electrostatic or mechanical damage to the analyzer. Do not drop tools into the analyzer or leave those after your procedures. Do not shorten or touch electric connections with metallic tools while operating inside the analyzer. Use common sense when operating inside a running analyzer.**

1. Scroll the TEST functions to PMT.
2. Supply zero gas to the analyzer.
3. With the instrument still running, carefully remove the analyzer cover. Take extra care not to touch any of the inside wiring with the metal cover or your body. Do not drop screws or tools into a running analyzer!
4. Shine a powerful flashlight or portable incandescent light at the inlet and outlet fitting and at all of the joints of the sample chamber as well as around the PMT





housing. The PMT value should not respond to the light, the PMT signal should remain steady within its usual noise performance.

5. If there is a PMT response to the external light, symmetrically tighten the sample chamber mounting screws or replace the 1/4" vacuum tubing with new, black PTFE tubing (this tubing will fade with time and become transparent). Often, light leaks are also caused by O-rings being left out of the assembly.
6. Carefully replace the analyzer cover.
7. If tubing was changed, carry out a leak check (refer to Section 9.3.6).

### 9.3.6. Detailed Pressure Leak Check

Obtain a leak checker similar to Teledyne Analytical Instruments P/N 01960, which contains a small pump, shut-off valve, and pressure gauge to create both over-pressure and vacuum. Alternatively, a tank of pressurized gas, with the two stage regulator adjusted to  $\leq 15$  psi, a shutoff valve and pressure gauge may be used.

#### ATTENTION

-----  
**COULD DAMAGE INSTRUMENT AND VOID WARRANTY**

**Once tube fittings have been wetted with soap solution under a pressurized system, do not apply or re-apply vacuum as this will cause soap solution to be sucked into the instrument, contaminating inside surfaces.**

**Do not exceed 15 psi when pressurizing the system.**  
-----

1. Turn OFF power to the instrument and remove the instrument cover.
2. Install a leak checker or a tank of gas (compressed, oil-free air or nitrogen) as described above on the sample inlet at the rear panel.
3. Pressurize the instrument with the leak checker or tank gas, allowing enough time to fully pressurize the instrument through the critical flow orifice.
4. Check each tube connection (fittings, hose clamps) with soap bubble solution, looking for fine bubbles.
5. Once the fittings have been wetted with soap solution, do not re-apply vacuum as it will draw soap solution into the instrument and contaminate it.
6. Do not exceed 15 psi pressure.
7. If the instrument has the zero and span valve option, the normally closed ports on each valve should also be separately checked. Connect the leak checker to the normally closed ports and check with soap bubble solution.
8. If the analyzer is equipped with an IZS Option, connect the leak checker to the Dry Air inlet and check with soap bubble solution.
9. Once the leak has been located and repaired, the leak-down rate of the indicated pressure should be less than 1 in-Hg-A (0.4 psi) in 5 minutes after the pressure is turned off.

- Clean soap solution from all surfaces, re-connect the sample and exhaust lines and replace the instrument cover. Restart the analyzer.

### 9.3.7. Performing a Sample Flow Check

#### IMPORTANT

#### IMPACT ON READINGS OR DATA

Use a separate, calibrated flow meter capable of measuring flows between 0 and 1000 cm<sup>3</sup>/min to measure the gas flow rate through the analyzer. For this procedure, do not refer to the built in flow measurement shown in the front panel display screen.

Sample flow checks are useful for monitoring the actual flow of the instrument, to monitor drift of the internal flow measurement. A decreasing, actual sample flow may point to slowly clogging pneumatic paths, most likely critical flow orifices or sintered filters. To perform a sample flow check:

- Disconnect the sample inlet tubing from the rear panel SAMPLE port (Figure 3-4).
- Attach the outlet port of a flow meter to the sample inlet port on the rear panel. Ensure that the inlet to the flow meter is at atmospheric pressure.
- The sample flow measured with the external flow meter should be 650 cm<sup>3</sup>/min  $\pm$  10%.
- Low flows indicate blockage somewhere in the pneumatic pathway. Refer to troubleshooting Section 10.2 for more information on how to fix this.

### 9.3.8. Hydrocarbon Scrubber (*Kicker*)

There are two possible types of problems that can occur with the scrubber: pneumatic leaks and contamination that ruins the inner tube's ability to absorb hydrocarbons.

#### 9.3.8.1. Checking the Scrubber for Leaks

Leaks in the outer tubing of the scrubber can be found using the procedure described in Section 9.3.6. Use the following method to determine if a leak exists in the inner tubing of the scrubber.

This procedure requires a pressurized source of air (chemical composition is unimportant) capable of supplying up to 15 psiA and a leak checking fixture such as the one illustrated in Figure 9-3.

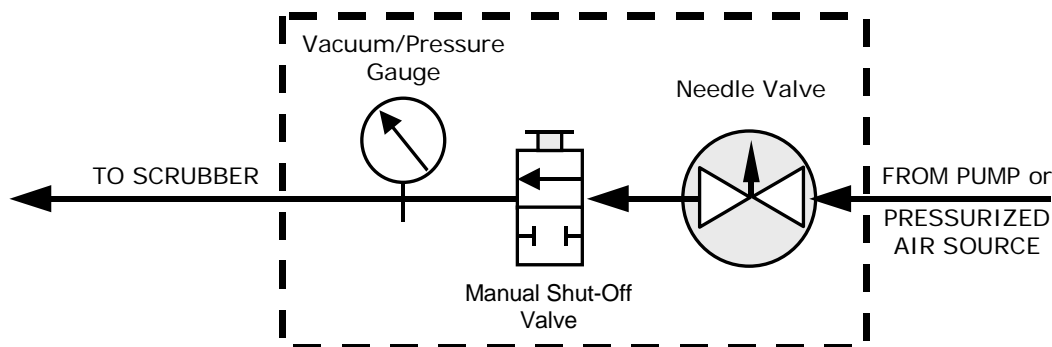
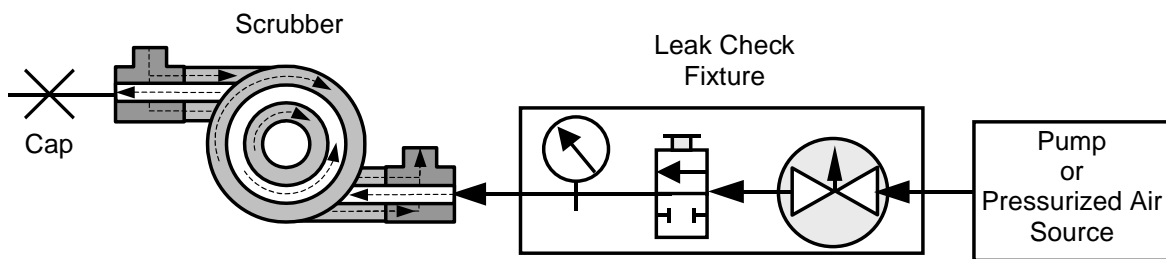

Figure 9-3: Simple Leak Check Fixture



1. Turn off the analyzer.
2. Disconnect the pneumatic tubing attached to both ends of the scrubber's inner tubing.
3. One end is connected to the sample particulate filter assembly and the other end is connected to the reaction cell assembly.
4. Both ends are made of the 1/8" black Teflon tubing.
5. Cap one end of the hydrocarbon scrubber.
6. Attach the pressurized air source to the other end of the scrubber inner tubing with the leak check fixture in line.



**Figure 9-4: Hydrocarbon Scrubber Leak Check Setup**

7. Use the needle valve to adjust the air input until the gauge reads 15 psiA.

**ATTENTION**

-----  
**COULD DAMAGE INSTRUMENT AND VOID WARRANTY**

**Do not exceed a pressure of more than 15 psia.**

**Do not pull the vacuum through the scrubber.**  
 -----

8. Close the shut-off valve.
9. Wait 5 minutes.

If the gauge pressure drops >1 psi within 5 minutes, then the hydrocarbon scrubber has an internal leak and must be replaced. Contact Teledyne Analytical Instruments's Customer Service.

## 10. TROUBLESHOOTING & SERVICE

This section contains a variety of methods for identifying and solving performance problems with the analyzer.

**Note:**

To support your understanding of the technical details of maintenance, Section 11, *Principles of Operation*, provides information about how the instrument works.



**CAUTION**

THE OPERATIONS OUTLINED IN THIS SECTION MUST BE PERFORMED BY QUALIFIED MAINTENANCE PERSONNEL ONLY.



**WARNING**

**RISK OF ELECTRICAL SHOCK**

SOME OPERATIONS NEED TO BE CARRIED OUT WITH THE ANALYZER OPEN AND RUNNING. EXERCISE CAUTION TO AVOID ELECTRICAL SHOCKS AND ELECTROSTATIC OR MECHANICAL DAMAGE TO THE ANALYZER. DO NOT DROP TOOLS INTO THE ANALYZER OR LEAVE THOSE AFTER YOUR PROCEDURES. DO NOT SHORTEN OR TOUCH ELECTRIC CONNECTIONS WITH METALLIC TOOLS WHILE OPERATING INSIDE THE ANALYZER. USE COMMON SENSE WHEN OPERATING INSIDE A RUNNING ANALYZER.

**Note**

The front panel of the analyzer is hinged at the bottom and may be opened to gain access to various components mounted on the panel itself or located near the front of the instrument (such as the particulate filter).

Remove the locking screw located at the right-hand side of the front panel.

### 10.1. General Troubleshooting

The 6200T has been designed so that problems can be rapidly detected, evaluated and repaired. During operation, it continuously performs diagnostic tests and provides the ability to evaluate its key operating parameters without disturbing monitoring operations.

The following table provides a general guide to troubleshooting the Model 6200T.

Problem	Corrective Action
NO POWER:	Plugged in? Switched on? Circuit breaker Tripped?
NOT HEATING:	PV/SV switch to PV. Is it heating? PV/SV switch to SV. Set point correct? Socket in place on back of temperature controller?



Problem	Corrective Action
	Check M501TS Wiring Diagram in the Appendix Thermocouple has failed? 'UUUU' shown on front panel of 501TS. Also, check thermocouple resistance.
TS ANALYZER UNSTABLE:	Quick Leak-check.
EFFICIENCY <90%:	Leaking? Leak-check. Plugged? Compare flow through and bypassing converter. Flow too high? Set-point temperature optimized? Span gas correct? Contaminated? Check inside of Teflon tubing
CONVERTER TEMP UNSTABLE:	Perform Auto-Tune procedure in Section 3.4.1.1.

A systematic approach to troubleshooting will generally consist of the following five steps:

1. Note any **WARNING MESSAGES** and take corrective action as necessary.
2. Examine the values of all TEST functions and compare them to factory values. Note any major deviations from the factory values and take corrective action.
3. Use the internal electronic status LEDs to determine whether the electronic communication channels are operating properly.
4. Verify that the DC power supplies are operating properly by checking the voltage test points on the relay PCA.
5. Note that the analyzer's DC power wiring is color-coded and these colors match the color of the corresponding test points on the relay PCA.
6. Suspect a leak first!
  - Customer service data indicate that the majority of all problems are eventually traced to leaks in the internal pneumatics of the analyzer or the diluent gas and source gases delivery systems.
  - Check for gas flow problems such as clogged or blocked internal/external gas lines, damaged seals, punctured gas lines, a damaged / malfunctioning pumps, etc.
7. Follow the procedures defined in Section 10.5 to confirm that the analyzer's vital functions are working (power supplies, CPU, relay PCA, touch-screen display, PMT cooler, etc.).
  - Refer to Figure 3-5 for the general layout of components and sub-assemblies in the analyzer.

### 10.1.1. Fault Diagnostics with Warning Messages

The most common and/or serious instrument failures will result in a warning message displayed on the front panel.

Table 10-1 contains a list of warning messages, along with their meaning and recommended corrective action.

It should be noted that if more than two or three warning messages occur at the same time, it is often an indication that some fundamental analyzer sub-system (power supply, relay board, motherboard) has failed rather than an indication of the specific failures referenced by the warnings. In this case, a combined-error analysis needs to be performed.

The analyzer will alert the user that a Warning message is active by flashing the FAULT LED and displaying the Warning message in the Param field along with the CLR button (press to clear Warning message). The MSG button displays if there is more than one warning in queue or if you are in the TEST menu and have not yet cleared the message. The following display/touchscreen examples provide an illustration of each:

To view or clear a warning message press:

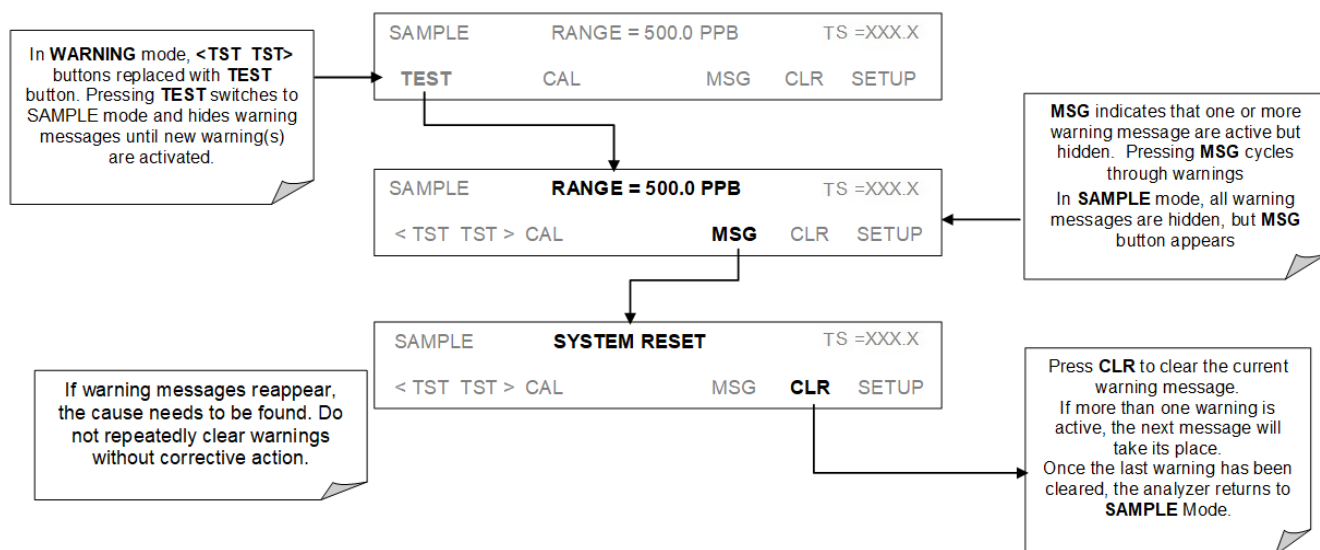

Figure 10-1: Viewing and Clearing Warning Messages

Table 10-1: Warning Messages - Indicated Failures

Warning Message	Fault Condition	Possible Causes
<b>ANALOG CAL WARNING</b>	The instruments A/D circuitry or one of its analog outputs is not calibrated	<ul style="list-style-type: none"> <li>A parameter for one of the analog outputs, even one not currently being used, has been changed and the analog output calibration routine was not re-run.</li> <li>A/D circuitry failure on motherboard.</li> <li>Other motherboard electronic failure</li> </ul>
<b>BOX TEMP WARNING</b>	Box Temp is < 5°C or > 48°C.	<p>NOTE: Box temperature typically runs ~7°C warmer than ambient temperature.</p> <ul style="list-style-type: none"> <li>Poor/blocked ventilation to the analyzer.</li> <li>Stopped exhaust-fan.</li> <li>Ambient temperature outside of specified range</li> </ul>



Warning Message	Fault Condition	Possible Causes
CANNOT DYN SPAN	Dynamic Span operation failed	<ul style="list-style-type: none"> <li>Measured concentration value is too high or low.</li> <li>Concentration slope value too high or too low</li> </ul>
CANNOT DYN ZERO	Dynamic Zero operation failed	<ul style="list-style-type: none"> <li>Measured concentration value is too high.</li> <li>Concentration offset value too high.</li> </ul>
CONFIG INITIALIZED	Configuration and Calibration data reset to original Factory state.	<ul style="list-style-type: none"> <li>Failed disk on module</li> <li>User erased data</li> </ul>
DARK CAL WARNING	The Dark Cal signal is higher than 200 mV.	<ul style="list-style-type: none"> <li>Light leak in reaction cell</li> <li>Shutter solenoid is not functioning</li> <li>Failed relay board</li> <li>I<sup>2</sup>C bus failure</li> <li>Loose connector/wiring</li> <li>PMT preamp board bad or out of cal</li> </ul>
DATA INITIALIZED	Data Storage in DAS was erased	<ul style="list-style-type: none"> <li>Failed disk on module</li> <li>User cleared data</li> </ul>
HVPS WARNING	High voltage power supply output is <400 V or >900 V	<ul style="list-style-type: none"> <li>High voltage power supply is bad</li> <li>High voltage power supply is out of cal</li> <li>A/D converter circuitry is bad</li> </ul>
IZS TEMP WARNING	On units with IZS options installed: The permeation tube temperature is Sample chamber temperature is < 45°C or > 55°C	<ul style="list-style-type: none"> <li>Bad IZS heater</li> <li>Bad IZS temperature sensor</li> <li>Bad relay controlling the IZS heater</li> <li>Entire relay board is malfunctioning</li> <li>I<sup>2</sup>C bus malfunction</li> <li>Failure of thermistor interface circuitry on motherboard</li> </ul>
PMT DET WARNING	PMT detector output is > 4995 mV	<ul style="list-style-type: none"> <li>Failed PMT</li> <li>Malfunctioning PMR preamp board</li> <li>A/D converter circuitry failure</li> </ul>
PMT TEMP WARNING	PMT temperature is < 2°C or > 12°C	<ul style="list-style-type: none"> <li>Bad PMT thermo-electric cooler</li> <li>Failed PMT TEC driver circuit</li> <li>Bad PMT preamp board</li> <li>Failed PMT temperature sensor</li> <li>Loose wiring between PMT temperature sensor and PMT Preamp board</li> <li>Malfunction of analog sensor input circuitry on motherboard</li> </ul>
RCELL TEMP WARNING	Sample chamber temperature is < 45°C or > 55°C	<ul style="list-style-type: none"> <li>Bad reaction cell heater</li> <li>Bad reaction cell temperature sensor</li> <li>Bad relay controlling the reaction cell heater</li> <li>Entire relay board is malfunctioning</li> <li>I<sup>2</sup>C bus malfunction</li> </ul>
REAR BOARD NOT DET	Mother Board not detected on power up.	<ul style="list-style-type: none"> <li>Warning only appears on serial I/O COMM port(s)</li> <li>Front panel display will be frozen, blank or will not respond.</li> <li>Massive failure of mother board.</li> </ul>
SAMPLE FLOW WARN	Sample flow rate is < 500 cc/min or > 1000 cc/min.	<ul style="list-style-type: none"> <li>Failed sample pump</li> <li>Blocked sample inlet/gas line</li> <li>Dirty particulate filter</li> <li>Leak downstream of critical flow orifice</li> <li>Failed flow sensor/circuitry</li> </ul>

Warning Message	Fault Condition	Possible Causes
SAMPLE PRES WARN	Sample Pressure is <10 in-Hg or > 35 in-Hg <sup>1</sup>	<ul style="list-style-type: none"> <li>• If sample pressure is &lt; 10 in-hg:               <ul style="list-style-type: none"> <li>○ Blocked particulate filter</li> <li>○ Blocked sample inlet/gas line</li> <li>○ Failed pressure sensor/circuitry</li> </ul> </li> <li>• If sample pressure is &gt; 35 in-hg:               <ul style="list-style-type: none"> <li>○ Blocked vent line on pressurized sample/zero/span gas supply.</li> <li>○ Bad pressure sensor/circuitry</li> </ul> </li> </ul>
SYSTEM RESET	The computer has rebooted.	<ul style="list-style-type: none"> <li>• This message occurs at power on. If it is confirmed that power has not been interrupted:</li> <li>• Failed +5 VDC power,</li> <li>• Fatal error caused software to restart</li> <li>• Loose connector/wiring</li> </ul>
UV LAMP WARNING	The UV lamp intensity is < 600mV or > 4995 mV	<ul style="list-style-type: none"> <li>• UV lamp is bad.</li> <li>• Reference detector is bad or out of adjustment.</li> <li>• Mother board analog sensor input circuitry has failed.</li> <li>• Fogged or damaged lenses/filters in UV light path</li> <li>• A/D converter circuitry failure.</li> <li>• Light leak in reaction cell</li> <li>• Shutter solenoid stuck closed</li> </ul>

<sup>1</sup> Normally 29.92 in-Hg at sea level decreasing at 1 in-Hg per 1000 ft of altitude (with no flow – pump disconnected).

**IMPORTANT****IMPACT ON READINGS OR DATA**

**A failure of the analyzer's CPU, motherboard or power supplies can result in any or ALL of the above messages.**

### 10.1.2. Fault Diagnosis with Test Functions

Besides being useful as predictive diagnostic tools, the TEST functions, viewable from the front panel, can be used to isolate and identify many operational problems when combined with a thorough understanding of the analyzer's principles of operation (refer to Section 11). The acceptable ranges for these test functions are listed in Table 10-2. The actual values for these test functions on checkout at the factory were also listed in the *Final Test and Validation Data Sheet*, which was shipped with the instrument. Values outside the acceptable ranges indicate a failure of one or more of the analyzer's subsystems. Functions with values that are within the acceptable range but have significantly changed from the measurements recorded on the factory data sheet may also indicate a failure or a maintenance item. Table 10-2 contains some of the more common causes for these values to be out of range.

**IMPORTANT****IMPACT ON READINGS OR DATA**

**A value of "XXXX" displayed for any of these TEST functions indicates an OUT OF RANGE reading.**





Note

Sample Pressure measurements are represented in terms of absolute pressure because this is the least ambiguous method reporting gas pressure. Absolute atmospheric pressure is about 29.92 in-Hg-A at sea level. It decreases about 1 in-Hg per 1000 ft gain in altitude. A variety of factors such as air conditioning systems, passing storms, and air temperature, can also cause changes in the absolute atmospheric pressure.

Table 10-2: Test Functions - Possible Causes for Out-Of-Range Values

TEST FUNCTION	NOMINAL VALUE(S)	POSSIBLE CAUSE(S)
STABIL	≤1 ppb with Zero Air	Faults that cause high stability values are: pneumatic leak; low or very unstable UV lamp output; light leak; faulty HVPS; defective preamp board; aging detectors; PMT recently exposed to room light; dirty/contaminated reaction cell.
SAMPLE FL	650 cm <sup>3</sup> /min ± 10%	Faults are caused due to: clogged critical flow orifice; pneumatic leak; faulty flow sensor; sample line flow restriction.
PMT	-20 TO 150 mV with Zero Air	High or noisy readings could be due to: calibration error; pneumatic leak; excessive background light; aging UV filter; low UV lamp output; PMT recently exposed to room light; light leak in reaction cell; reaction cell contaminated HVPS problem. <i>It takes 24-48 hours for the PMT exposed to ambient light levels to adapt to dim light.</i>
NORM PMT	0-5000 mV, 0-20,000 ppb @ Span Gas Concentration	Noisy Norm PMT value (assuming unchanging SO <sub>2</sub> concentration of sample gas): Calibration error; HVPS problem; PMT problem.
UV LAMP SIGNAL	2000 - 4000 mV	This is the instantaneous reading of the UV lamp intensity. Low UV lamp intensity could be due to: aging UV lamp; UV lamp position out of alignment; faulty lamp transformer; aging or faulty UV detector; UV detector needs adjusting; dirty optical components. Intensity lower than 600 mV will cause <b>UV LAMP WARNING</b> . Most likely cause is a UV lamp in need of replacement.
LAMP RATIO	30% TO 120%	The current output of the UV reference detector divided by the reading stored in the CPU's memory from the last time a UV Lamp calibration was performed. Out of range lamp ratio could be due to: malfunctioning UV lamp; UV lamp position out of alignment; faulty lamp transformer; aging or faulty UV detector; dirty optical components; pin holes or scratches in the UV optical filters; light leaks.
STR LGT	≤ 100 ppb / Zero Air	High stray light could be caused by: aging UV filter; contaminated reaction cell; light leak; pneumatic leak.
DRK PMT	-50 to +200 mV	High dark PMT reading could be due to: light leak; shutter not closing completely; high pmt temperature; high electronic offset.
DRK LMP	-50 to +200 mV	High dark UV detector could be caused by: light leak; shutter not closing completely; high electronic offset.
HVPS	≈ 400 V to 900 V	Incorrect HVPS reading could be caused by; HVPS broken; preamp board circuit problems.

TEST FUNCTION	NOMINAL VALUE(S)	POSSIBLE CAUSE(S)
RCELL TEMP	50°C ± 1°C	Incorrect temperature reading could be caused by: malfunctioning heater; relay board communication (I <sup>2</sup> C bus); relay burnt out
BOX TEMP	Ambient + ≈ 5°C	Incorrect temperature reading could be caused by: Environment out of temperature operating range; broken thermistor; runaway heater
PMT TEMP	7°C ± 2°C Constant	Incorrect temperature reading could be caused by: TEC cooling circuit broken; High chassis temperature; 12V power supply
IZS TEMP (option)	50°C ± 1°C	Malfunctioning heater; relay board communication (I <sup>2</sup> C bus); relay burnt out
PRESS	Ambient ± 2 IN-HG-A	Incorrect sample gas pressure could be due to: pneumatic leak; malfunctioning valve; malfunctioning pump; clogged flow orifices; sample inlet overpressure; faulty pressure sensor
SLOPE	1.0 ± 0.3	Slope out of range could be due to: poor calibration quality; span gas concentration incorrect; leaks; UV Lamp output decay.
OFFSET	< 250 mV	High offset could be due to: incorrect span gas concentration/contaminated zero air/leak; low-level calibration off; light leak; aging UV filter; contaminated reaction cell; pneumatic leak.
TIME OF DAY	Current Time	Incorrect Time could be caused by: Internal clock drifting; move across time zones; daylight savings time?

### 10.1.3. Using the Diagnostic Signal I/O Functions

The signal I/O parameters found under the diagnostics (DIAG) menu combined with a thorough understanding of the instrument's principles of operation are useful for troubleshooting in three ways:

- The technician can view the raw, unprocessed signal level of the analyzer's critical inputs and outputs.
- All of the components and functions that are normally under instrument control can be manually changed.
- Analog and digital output signals can be manually controlled.

This allows a user to systematically observe the effect of these functions on the operation of the analyzer.

Figure 10-2 shows an example of how to use the signal I/O menu to view the raw voltage of an input signal or to control the state of an output voltage or control signal. The specific parameter will vary depending on the situation. Please note that the analyzer will freeze its concentration output while in the diagnostic signal I/O menu. This is because manually changing I/O outputs can invalidate the instrument reading.



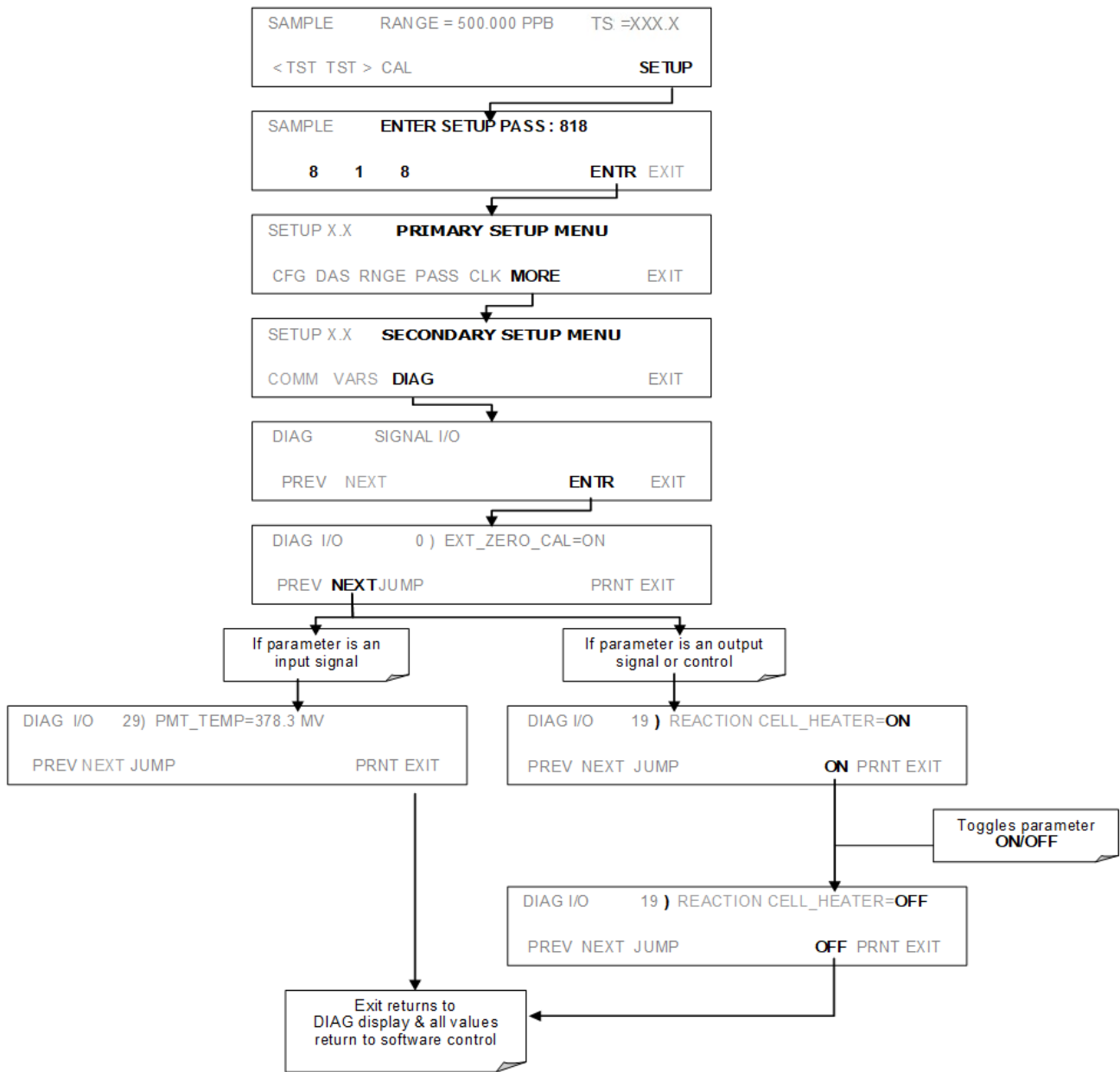

Figure 10-2: Example of Signal I/O Function

## 10.2. Gas Flow Problems

The standard analyzer has one main flow path. With the IZS option installed, there is a second flow path through the IZS oven that runs whenever the IZS is on standby to purge SO<sub>2</sub> from the oven chamber. The IZS flow is not measured so there is no reading for it on the front panel display. The full flow diagrams (refer to Figure 3- and Figure 3-) help in troubleshooting flow problems. In general, flow problems can be divided into three categories:

- Flow is too high
- Flow is greater than zero, but is too low, and/or unstable
- Flow is zero (no flow)

When troubleshooting flow problems, it is essential to confirm the actual flow rate without relying on the analyzer's flow display. The use of an independent, external flow meter to perform a flow check as described in Section 9.3.7 is essential.

### 10.2.1. Zero or Low Sample Flow

If the pump is operating but the unit reports a **XXXX** gas flow, do the following three steps:

- Check for actual sample flow
- Check pressures
- Carry out a leak check

To check the actual sample flow, disconnect the sample tube from the sample inlet on the rear panel of the instrument. Ensure that the unit is in basic SAMPLE mode. Place a finger over the inlet and see if it gets sucked in by the vacuum or, more properly, use a flow meter to measure the actual flow. If a proper flow of approximately 650 cm<sup>3</sup>/min exists, contact customer service. If there is no flow or low flow, continue with the next step.

Check that the sample pressure is at or around 28 (or about 1 in-Hg-A below ambient atmospheric pressure).

### 10.2.2. High Flow

Flows that are significantly higher than the allowed operating range (typically  $\pm 10$ -11% of the nominal flow) should not occur in the M unless a pressurized sample, zero or span gas is supplied to the inlet ports. Be sure to vent excess pressure and flow just before the analyzer inlet ports.

When supplying sample, zero or span gas at ambient pressure, a high flow would indicate that one or more of the critical flow orifices are physically broken (very unlikely case), allowing more than nominal flow, or were replaced with an orifice of wrong specifications. If the flows are more than 15% higher than normal, we recommend that the technician find and correct the cause of the flow problem,

## 10.3. Calibration Problems

This section provides information regarding possible causes of various calibration problems.

### 10.3.1. Negative Concentrations

Negative concentration values may be caused due to the following:

- A slight, negative signal is normal when the analyzer is operating under zero gas and the signal is drifting around the zero calibration point. This is caused by the analyzer's zero noise and may cause reported concentrations to be negative for a few seconds at a time down to -5 ppb, but should alternate with similarly high, positive values.



- Mis-calibration is the most likely explanation for negative concentration values. If the zero air contained some SO<sub>2</sub> gas (contaminated zero air or a worn-out zero air scrubber) and the analyzer was calibrated to that concentration as “zero”, the analyzer may report negative values when measuring air that contains little or no SO<sub>2</sub>. The same problem occurs, if the analyzer was zero-calibrated using ambient air or span gas.
- If the response offset test function for SO<sub>2</sub> (**OFFSET**) are greater than 150 mV, a failed PMT or high voltage supply, or sample chamber contamination, could be the cause.

### 10.3.2. No Response

If the instrument shows no response (display value is near zero) even though sample gas is supplied properly and the instrument seems to perform correctly,

- Confirm response by supplying SO<sub>2</sub> span gas of about 80% of the range value to the analyzer.
- Check the sample flow rate for proper value.
- Check for disconnected cables to the sensor module.
- Carry out an electrical test with the **ELECTRICAL TEST** procedure in the diagnostics menu, refer to Section 5.9.5. If this test produces a concentration reading, the analyzer’s electronic signal path is working.
- Carry out an optical test using the OPTIC TEST procedure in the diagnostics menu, refer to Section 5.9.4. If this test results in a concentration signal, then the PMT sensor and the electronic signal path are operating properly. If the M passes both ETEST and OTEST, the instrument is capable of detecting light and processing the signal to produce a reading. Therefore, the problem must be in the pneumatics, optics or the UV lamp/lamp driver.

### 10.3.3. Unstable Zero and Span

Leaks in the 6200T or in the external gas supply and vacuum systems are the most common source of unstable and non-repeatable concentration readings.

- Check for leaks in the pneumatic systems as described in Section 9.3.6. Consider pneumatic components in the gas delivery system outside the 6200T such as a change in zero air source (ambient air leaking into zero air line or a worn-out zero air scrubber) or a change in the span gas concentration due to zero air or ambient air leaking into the span gas line.
- Once the instrument passes a leak check, perform a flow check (refer to Section 9.3.7) to ensure that the instrument is supplied with adequate sample gas.
- Confirm the UV lamp, sample pressure and sample temperature readings are correct and steady.
- Verify that the sample filter element is clean and does not need to be replaced.



### 10.3.4. Inability to Span - No SPAN Button

In general, the 6200T will not display certain control buttons whenever the actual value of a parameter is outside of the expected range for that parameter. If the calibration menu does not show a SPAN button when carrying out a span calibration, the actual concentration must be outside of the range of the expected span gas concentration, which can have several reasons.

- Verify that the expected concentration is set properly to the actual span gas concentration in the **CONC** sub-menu.
- Confirm that the SO<sub>2</sub> span gas source is accurate.
- If you are using bottle calibration gas and have recently changed bottles, bottle to bottle variation may be the cause.
- Check for leaks in the pneumatic systems as described in Section 10.5.1. Leaks can dilute the span gas and, hence, the concentration that the analyzer measures may fall short of the expected concentration defined in the **CONC** sub-menu.
- If the physical, low-level calibration has drifted (changed PMT response) or was accidentally altered by the user, a low-level calibration may be necessary to get the analyzer back into its proper range of expected values. One possible indicator of this scenario is a slope or offset value that is outside of its allowed range (0.7-1.3 for slope, -20 to 150 for offsets).

### 10.3.5. Inability to Zero - No ZERO Button

In general, the 6200T will not display certain control buttons whenever the actual value of a parameter is outside of the expected range for that parameter. If the calibration menu does not show a ZERO button when carrying out a zero calibration, the actual gas concentration must be significantly different from the actual zero point (as per last calibration), which can have several reasons.

- Confirm that there is a good source of zero air. If the IZS option is installed, compare the zero reading from the IZS zero air source to an external zero air source using SO<sub>2</sub>-free air. Check any zero air scrubber for performance and replacement (refer to Section 9.3.3).
- Check to ensure that there is no ambient air leaking into the zero air line. Check for leaks in the pneumatic systems as described in Section 9.3.6.

### 10.3.6. Non-Linear Response

The 6200T was factory calibrated and should be linear to within 1% of full scale. Common causes for non-linearity are:

- Leaks in the pneumatic system. Leaks can add a constant of ambient air, zero air or span gas to the current sample gas stream, which may be changing in concentrations as the linearity test is performed. Check for leaks as described in Section 9.3.6.
- The calibration device is in error. Check flow rates and concentrations, particularly when using low concentrations. If a mass flow calibrator is used and the flow is less than 10% of the full scale flow on either flow controller, you may need to purchase lower concentration standards.



- The standard gases may be mislabeled as to type or concentration. Labeled concentrations may be outside the certified tolerance.
- The sample delivery system may be contaminated. Check for dirt in the sample lines or sample chamber.
- Calibration gas source may be contaminated.
- Dilution air contains sample or span gas.
- Sample inlet may be contaminated with SO<sub>2</sub> exhaust from this or other analyzers. Verify proper venting of the analyzer's exhaust.
- Span gas overflow is not properly vented and creates a back-pressure on the sample inlet port. Also, if the span gas is not vented at all and does not supply enough sample gas, the analyzer may be evacuating the sample line. Ensure to create and properly vent excess span gas.
- If the instrument is equipped with an internal IZS valve option and the SO<sub>2</sub> span value is continuously trending downward, the IZS permeation tube may require replacement.

### 10.3.7. Discrepancy Between Analog Output and Display

If the concentration reported through the analog outputs does not agree with the value reported on the front panel, you may need to re-calibrate the analog outputs. This becomes more likely when using a low concentration or low analog output range. Analog outputs running at 0.1 V full scale should always be calibrated manually. Refer to the Configurable Analog Outputs Addendum P/N MQ7859.

## 10.4. Other Performance Problems

Dynamic problems (i.e. problems which only manifest themselves when the analyzer is monitoring sample gas) can be the most difficult and time consuming to isolate and resolve. The following section provides an itemized list of the most common dynamic problems with recommended troubleshooting checks and corrective actions.

### 10.4.1. Excessive noise

Excessive noise levels under normal operation usually indicate leaks in the sample supply or the analyzer itself. Ensure that the sample or span gas supply is leak-free and carry out a detailed leak check as described earlier in this section.

Another possibility of excessive signal noise may be the preamplifier board, the high voltage power supply and/or the PMT detector itself. Contact the factory on trouble-shooting these components.

### 10.4.2. Slow Response

If the analyzer starts responding too slowly to any changes in sample, zero or span gas, check for the following:

- Dirty or plugged sample filter or sample lines.
- Sample inlet line is too long.
- Dirty or plugged critical flow orifices. Check flows, pressures and, if necessary, change orifices (refer to Section 9.3.4).
- Wrong materials in contact with sample - use Teflon materials only.



- Sample vent line is located too far from the instrument sample inlet causing a long mixing and purge time. Locate sample inlet (overflow) vent as close as possible to the analyzer's sample inlet port.
- Dirty sample chamber.
- Insufficient time allowed for purging of lines upstream of the analyzer.
- Insufficient time allowed for SO<sub>2</sub> calibration gas source to become stable.

### 10.4.3. The Analyzer Doesn't Appear on the LAN or Internet

Most problems related to Internet communications via the Ethernet card will be due to problems external to the analyzer (e.g. bad network wiring or connections, failed routers, malfunctioning servers, etc.) However, there are several symptoms that indicate the problem may be with the Ethernet card itself.

If neither of the Ethernet cable's two status LED's (located on the back of the cable connector) is lit while the instrument is connected to a network:

- Verify that the instrument is being connected to an active network jack.
- Check the internal cable connection between the Ethernet card and the CPU board.

## 10.5. Subsystem Checkout

The preceding sections of this manual discussed a variety of methods for identifying possible sources of failures or performance problems within the analyzer. In most cases this included a list of possible causes and, in some cases, quick solutions or at least a pointer to the appropriate sections describing them. This section describes how to determine if a certain component or subsystem is actually the cause of the problem being investigated.

### 10.5.1. AC Power Configuration

The 6200T digital electronic systems will operate with any of the specified power regimes. As long as instrument is connected to 100-120 VAC or 220-240 VAC at either 50 or 60 Hz it will turn on and after about 30 seconds show a front panel display. Internally, the status LEDs located on the Motherboard, the Relay PCA and the CPU should turn on as soon as the power is supplied.

On the other hand, the analyzer's various non-digital components, such as the pump and the AC powered heaters, require that the relay board be properly configured for the type of power being supplied to the instrument.

#### ATTENTION

---

#### COULD DAMAGE INSTRUMENT AND VOID WARRANTY

**Plugging the analyzer into a power supply that is too high a voltage or frequency can damage the pump and the AC Heaters.**

**Plugging the analyzer into a power supply that is too low a voltage or frequency will cause these components to not operate properly.**

---

If the pump and the heaters are not working correctly and incorrect power configuration is suspected, check the serial number label located on the instrument's rear panel (refer to





Figure 3-4) to ensure that the instrument was configured for the same voltage and frequency being supplied.

If the information included on the label matches the line voltage, but you still suspect an AC power configuration problem:

For the heaters, check the power configuration jumpers located on the relay board (refer to Figure 10-3).

- If the Jumper block is WHITE the heaters are configured for 115 VAC at 60 Hz.
- If the Jumper block is BLUE the heaters are configured for 220, 240 VAC at 50 Hz.

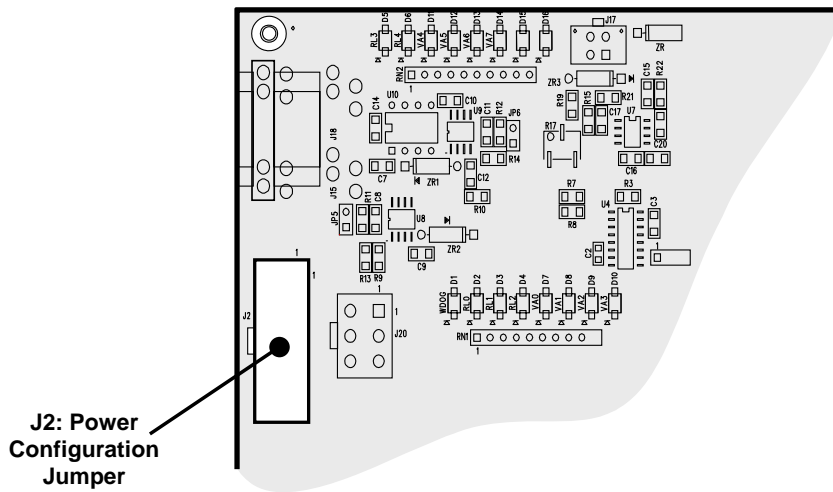

Figure 10-3: Location of Relay Board Power Configuration Jumper

AC Configuration of the pump is accomplished via an in-line, hard wired, set of connections. Call Teledyne Analytical Instruments’s Customer Service Department for more information.

### 10.5.2. DC Power Supply

If you have determined that the analyzer’s AC main power is working, but the unit is still not operating properly, there may be a problem with one of the instrument’s switching power supplies, which convert AC power to 5 and ±15 V (PS1) as well as +12 V DC power (PS2). The supplies can either have DC output at all or a noisy output (fluctuating).

To assist tracing DC Power Supply problems, the wiring used to connect the various printed circuit assemblies and DC powered components and the associated test points on the relay board follow a standard color-coding scheme as defined in Table 10-3.

Table 10-3: DC Power Test Point and Wiring Color Code

NAME	TEST POINT#	COLOR	DEFINITION
DGND	1	Black	Digital ground
+5V	2	Red	
AGND	3	Green	Analog ground
+15V	4	Blue	
-15V	5	Yellow	
+12V	6	Purple	
+12R	7	Orange	12 V return (ground) line

A voltmeter should be used to verify that the DC voltages are correct as listed in Table 10-3. An oscilloscope, in AC mode and with band limiting turned on, can be used to evaluate if the supplies are excessively noisy (>100 mV peak-to-peak).

**Table 10-4: DC Power Supply Acceptable Levels**

POWER SUPPLY	VOLTAGE	CHECK RELAY BOARD TEST POINTS				MIN V	MAX V
		FROM TEST POINT		TO TEST POINT			
		NAME	#	NAME	#		
PS1	+5	DGND	1	+5	2	+4.80	+5.25
PS1	+15	AGND	3	+15	4	+13.5	+16.0
PS1	-15	AGND	3	-15V	5	-14.0	-16.0
PS1	AGND	AGND	3	DGND	1	-0.05	+0.05
PS1	Chassis	DGND	1	Chassis	N/A	-0.05	+0.05
PS2	+12	+12V Ret	6	+12V	7	+11.8	+12.5
PS2	DGND	+12V Ret	6	DGND	1	-0.05	+0.05

### 10.5.3. I<sup>2</sup>C Bus

Operation of the I<sup>2</sup>C bus can be verified by observing the behavior of D1 on the relay PCA & D2 on the Valve Driver PCA . Assuming that the DC power supplies are operating properly, the I<sup>2</sup>C bus is operating properly if: D1 on the relay PCA and D2 of the Valve Driver PCA are flashing

There is a problem with the I<sup>2</sup>C bus if both D1 on the relay PCA and D2 of the Valve Driver PCA are ON/OFF constantly.

### 10.5.4. Touch-screen Interface

Verify the functioning of the touch screen by observing the display when pressing a touch-screen control button. Assuming that there are no wiring problems and that the DC power supplies are operating properly, but pressing a control button on the touch screen does not change the display, any of the following may be the problem:

- The touch-screen controller may be malfunctioning.
- The internal USB bus may be malfunctioning.

You can verify this failure by logging on to the instrument using APICOM or a terminal program. If the analyzer responds to remote commands and the display changes accordingly, the touch-screen interface may be faulty.

### 10.5.5. LCD Display Module

Verify the functioning of the front panel display by observing it when power is applied to the instrument. Assuming that there are no wiring problems and that the DC power supplies are operating properly, the display screen should light and show the splash screen and other indications of its state as the CPU goes through its initialization process.



### 10.5.6. Relay Board

The relay board circuit can most easily be checked by observing the condition of its status LEDs and the associated output when toggled on and off through the **SIGNAL I/O** function in the **DIAG** menu, refer to Section 5.9.1.

- If the front panel display responds to button presses and D1 on the relay board is not flashing, then either the I<sup>2</sup>C connection between the motherboard and the relay board is bad, or the relay board itself is bad.
- If D1 on the relay board is flashing, but toggling an output in the **Signal I/O** function menu does not toggle the output's status LED, then there is a circuit problem, or possibly a blown driver chip, on the relay board.
- If D1 on the Relay board is flashing and the status indicator for the output in question (heater, valve, etc.) toggles properly using the **Signal I/O** function, but the output device does not turn on/off, then the associated device (valve or heater) or its control device (valve driver, heater relay) is malfunctioning.

Several of the control devices are in sockets and can easily be replaced. The table below lists the control device associated with a particular function:

**Table 10-5: Relay Board Control Devices**

FUNCTION	CONTROL DEVICE	SOCKETED
Valve0 – Valve3	U5	Yes
Valve4 – Valve7	U6	Yes
All heaters	K1-K5	Yes

### 10.5.7. Motherboard

#### 10.5.7.1. A/D functions

A basic check of the analog to digital (A/D) converter operation on the motherboard is to use the **Signal I/O** function under the **DIAG** menu. Check the following two A/D reference voltages and input signals that can be easily measured with a voltmeter. Using the **Signal I/O** function (refer to Section 5.9.1), view the value of **REF\_4096\_MV** and **REF\_GND**.

- The nominal value for **REF\_4096\_MV** is 4096 mV ± 10 mV.
- The nominal value for **REF\_GND** is 0 mV ± 3 mV, respectively, of their nominal values (4096 and 0) and are
- If these signals are stable to within ±0.5 mV, the basic A/D converter is functioning properly.
- If these values fluctuate largely or are off by more than specified above, one or more of the analog circuits may be overloaded or the motherboard may be faulty.
- Choose one parameter in the Signal I/O function such as **SAMPLE\_PRESSURE** (refer to previous section on how to measure it). Compare its actual voltage with the voltage displayed through the **SIGNAL I/O** function. If the wiring is intact but there is a difference of more than ±10 mV between the measured and displayed voltage, the motherboard may be faulty.

### 10.5.7.2. Analog Output Voltages

To verify that the analog outputs are working properly, connect a voltmeter to the output in question and perform an analog output step test as described in Section 5.9.2.

For each of the steps, taking into account any offset that may have been programmed into the channel, the output should be within 1% of the nominal value listed in the Table 11-7 except for the 0% step, which should be within 2-3 mV. If one or more of the steps is outside of this range, a failure of one or both D/A converters and their associated circuitry on the motherboard is likely.

**Table 10-6: Analog Output Test Function - Nominal Values**

		FULL SCALE OUTPUT VOLTAGE			
		100MV	1V	5V	10V*
STEP	%	NOMINAL OUTPUT VOLTAGE			
1	0	0 mV	0	0	0
2	20	20 mV	0.2	1	2
3	40	40 mV	0.4	2	4
4	60	60 mV	0.6	3	6
5	80	80 mV	0.8	4	8
6	100	100 mV	1.0	5	10

\* Increase the Analog Out (AOUT) Cal Limits in the DIAG>Analog I/O Config menu.

### 10.5.7.3. Status Outputs

The procedure below can be used to test the Status outputs.

1. Connect a cable jumper between the "D" pin and the "▽" pin on the status output connector.
2. Connect a 1000 Ω resistor between the +5 V and the pin for the status output that is being tested.

**Table 10-7: Status Outputs Check Pin Out**

PIN (left to right)	STATUS
1	System Ok
2	Conc Valid
3	High Range
4	Zero Cal
5	Span Cal
6	Diag Mode
7	Spare
8	Spare

3. Connect a voltmeter between the "-" pin and the pin of the output being tested.
4. Under the **DIAG → SIGNAL I/O** menu (refer to Section 5.9.1), scroll through the inputs and outputs until you get to the output in question. Alternately turn on and off the output noting the voltage on the voltmeter, it should vary between 0 volts for ON and 5 volts for OFF.



#### 10.5.7.4. Control Inputs

The control input bits can be tested by the following procedure:

1. Connect a jumper from the +5 V pin on the STATUS connector to the U on the CONTROL IN connector.
2. Connect a second jumper from the  $\nabla$  pin on the STATUS connector to the A pin on the CONTROL IN connector. The instrument should switch from **SAMPLE** mode to **ZERO CAL R** mode.
3. Connect a second jumper from the  $\nabla$  pin on the STATUS connector to the B pin on the CONTROL IN connector. The instrument should switch from **SAMPLE** mode to **SPAN CAL R** mode.

In each case, the 6200T should return to SAMPLE mode when the jumper is removed.

#### 10.5.8. CPU

There are two major types of CPU board failures, a complete failure and a failure associated with the Disk-On-Module (DOM). If either of these failures occurs, contact the factory.

For complete failures, assuming that the power supplies are operating properly and the wiring is intact, the CPU is faulty if on power-on, the watchdog LED on the motherboard is not flashing.

In some rare circumstances, this failure may be caused by a bad IC on the motherboard, specifically U57, the large, 44 pin device on the lower right hand side of the board. If this is true, removing U57 from its socket will allow the instrument to start up but the measurements will be invalid.

If the analyzer stops during initialization (the front panel display shows a fault or warning message), it is likely that the DOM, the firmware or the configuration and data files have been corrupted.

#### 10.5.9. RS-232 Communication

This section provides general RS-232 communication information.

##### 10.5.9.1. General RS-232 Troubleshooting

Teledyne Analytical Instruments's analyzers use the RS-232 protocol as the standard, serial communications protocol. RS-232 is a versatile standard, which has been used for many years but, at times, is difficult to configure. Teledyne Analytical Instruments conforms to the standard pin assignments in the implementation of RS-232. Problems with RS-232 connections usually center around 4 general areas:

- Incorrect cabling and connectors. This is the most common problem. Refer to Section 3.3.1.7 for connector, pin-out and setup information.
- The communications (baud) rate and protocol parameters are incorrectly configured. Refer to 3.3.1.7 and 6.2 for baud rate information.
- The COMM port communications mode is set incorrectly (refer to Section **Error! Reference source not found.**).
- If a modem is used, additional configuration and wiring rules must be observed. Refer to Section 8.3.
- Incorrect setting of the DTE - DCE Switch. Refer to Section 6.1.



### 10.5.9.2. Modem or Terminal Operation

These are the general steps for troubleshooting problems with a modem connected to a Teledyne Analytical Instruments analyzer.

- Check cables for proper connection to the modem, terminal or computer.
- Check the correct position of the DTE/DCE switch as described in Section 6.1.
- Check the correct setup command (refer to Section 8.3).
- Verify that the Ready to Send (RTS) signal is at logic high. The 6200T sets Pin 7 (RTS) to greater than 3 volts to enable modem transmission.
- Ensure that the baud rate, word length, and stop bit settings between modem and analyzer match (refer to Sections 6.2.2 and 8.3).
- Use the RS-232 test function to send “w” characters to the modem, terminal or computer. Refer to Section 6.2.3.
- Get your terminal, modem or computer to transmit data to the analyzer (holding down the space bar is one way). The green LED on the rear panel should flicker as the instrument is receiving data.
- Ensure that the communications software is functioning properly.

### 10.5.10. Shutter System

To check the functionality of the UV light Shutter by manually activating it:

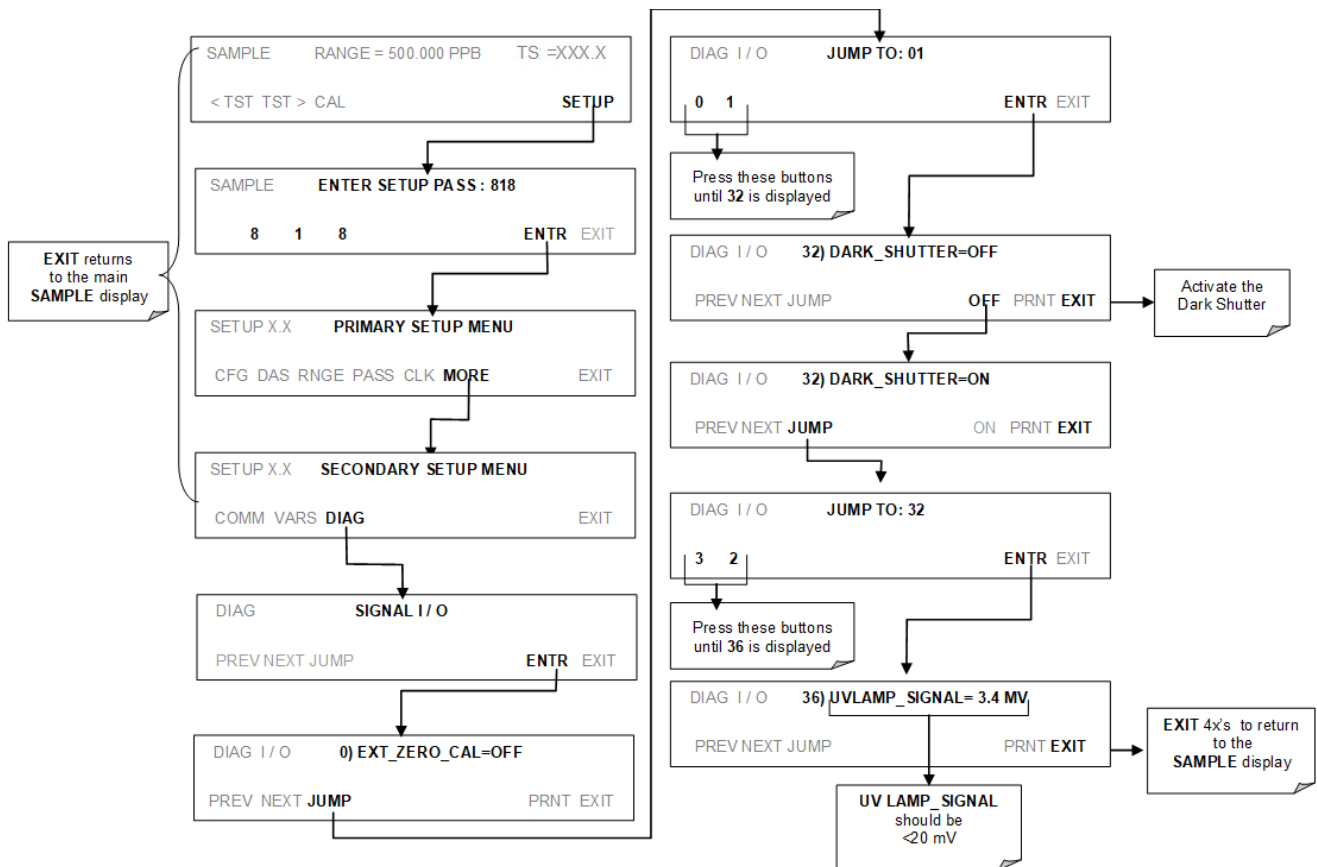

**Figure 10-4: Manual Activation of the UV Light Shutter**

### 10.5.11. PMT Sensor

The photo multiplier tube detects the light emitted by the UV excited fluorescence of SO<sub>2</sub>. It has a gain of about 500000 to 1000000. It is not possible to test the detector outside of the instrument in the field. The best way to determine if the PMT is working properly is by using the optical test (**OTEST**), which is described in Section 5.9.4. The basic method to diagnose a PMT fault is to eliminate the other components using **ETEST**, **OTEST** and specific tests for other sub-assemblies.

### 10.5.12. PMT Preamp Board

To check the correct operation of the preamplifier board, we suggest the technician carry out the electrical and optical tests described in 5.9.4 and 5.9.5.

If the **ETEST** fails, the preamplifier board may be faulty.

### 10.5.13. PMT Temperature Control PCA

The TEC control printed circuit assembly is located on the sensor housing assembly, under the slanted shroud, next to the cooling fins and directly above the cooling fan.

- If the red LED located on the top edge of this assembly is not glowing the control circuit is not receiving power.
- Check the analyzer's power supply, the relay board's power distribution circuitry and the wiring connecting them to the PMT temperature control PCA.

#### 10.5.13.1. TEC Control Test Points

Four test points are also located at the top of this assembly they are numbered left to right start with the T1 point immediately to the right of the power status LED. These test points provide information regarding the functioning of the control circuit.

To determine the current running through the control circuit, measure the voltage between **T1** and **T2**. Multiply that voltage by 10.

To determine the drive voltage being supplied by the control circuit to the TEC, measure the voltage between **T2** and **T3**.

- If this voltage is zero, the TEC circuitry is most likely open.
- If the voltage between T2 and T3 = 0 VDC and the voltage measured between T1 and T2 = 0 VDC there is most likely an open circuit or failed op amp on control PCA itself
- If the voltage between T2 and T3 = 0 VDC and the voltage measured between T1 to T2 is some voltage other than 0 VDC, the TEC is most likely shorted

**T4** is tied directly to ground. To determine the absolute voltage on any one of the other test points make a measurement between that test point and T4.

### 10.5.14. High Voltage Power Supply

The HVPS is located in the interior of the sensor module and is plugged into the PMT tube (refer to Figure 11-12). It requires 2 voltage inputs. The first is +15 which powers the supply. The second is the programming voltage which is generated on the Preamp Board. This power supply is unlike a traditional PMT HVPS. It is like having 10 independent power

supplies, one to each pin of the PMT. The test procedure below allows you to test each supply.

1. Check the **HVPS** test function via the front panel and record the reading level. Adjustment of the HVPS output level is covered in the hardware calibration procedure in Section 10.6.1.8.
2. Turn off the instrument.
3. Remove the cover and disconnect the 2 connectors at the front of the PMT housing.
4. Remove the end plate from the PMT housing.
5. Remove the HVPS/PMT assembly from the cold block inside the sensor. Un-plug the PMT.
6. Re-connect the 7 pin connector to the Sensor end cap, and power-up the instrument.
7. Check the voltages between the pairs of pins listed in Table 10-8. The result for each pair should be equal and approximately 10% of the reading level recorded in Step 1.

**Table 10-8: Example of HVPS Power Supply Outputs**

If HVPS reading = 700 VDC	
PIN PAIR	NOMINAL READING
1 → 2	70 VDC
2 → 3	70 VDC
3 → 4	70 VDC
4 → 5	70 VDC
5 → 6	70 VDC
6 → 7	70 VDC
7 → 8	70 VDC

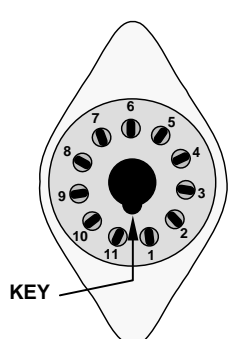

8. Turn off the instrument power, and re-connect the PMT tube, and then re-assemble the sensor.

If any faults are found in the test, the HVPS must be replaced. There are no user serviceable parts inside the HVPS.

### 10.5.15. Pneumatic Sensor Assembly

The pressure/flow sensor circuit board, located behind the sensor assembly, can be checked with a voltmeter using the following procedure, which assumes that the wiring is intact and that the motherboard and the power supplies are operating properly.

- Measure the voltage across TP1 and TP2, it should be  $10.0 \pm 0.25$  V. If not, the board may be faulty.
- Measure the voltage across capacitor C2; it should be  $5.0 \pm 0.25$  V. If not, the board may be faulty.





### 10.5.16. Sample Pressure

Measure the voltage across test points TP1 and TP4. With the sample pump disconnected or turned off, this voltage should be  $4500 \pm 250$  mV. With the pump running, it should be about 0.2 V less as the sample pressure drops by about 1 in-Hg-A from ambient pressure. If this voltage is significantly different, the pressure transducer S2 or the board may be faulty. A leak in the sample system to vacuum may also cause this voltage to be between about 0.6 and 4.5. Ensure that the front panel reading of the sample pressure is at about 1 in-Hg-A less than ambient pressure.

### 10.5.17. IZS Option

The zero/span valves and IZS options need to be enabled in the software (contact the factory on how to do this). Refer to Figure 3- and Figure 3- for a flow diagram with zero/span valve or IZS option.

- Check for the physical presence of the valves or the IZS option.
- Check that a working perm-tube is installed in the IZS oven assembly.
- Check front panel for correct software configuration. When the instrument is in SAMPLE mode, the front panel display should show CALS and CALZ buttons in the second line of the display. The presence of the buttons indicates that the option has been enabled in software. In addition, the IZS option is enabled if the TEST functions show a parameter named IZS TEMP.

The IZS option is heated with a proportional heater circuit and the temperature is maintained at  $50^{\circ}\text{C} \pm 1^{\circ}$ . Check the **IZS TEMP** function via front panel display (refer to Section 4.1.1) and the **IZS\_TEMP** signal voltage using the **SIGNAL I/O** function under the **DIAG** Menu (refer to Section 5.9.1).

At  $50^{\circ}\text{C}$ , the temperature signal from the IZS thermistor should be around 2500 mV.

### 10.5.18. Box Temperature

The box temperature sensor (thermistor) is mounted on the motherboard at the bottom, right corner of the CPU board when looking at it from the front. It cannot be disconnected to check its resistance. Box temperature will vary with, but will always read about  $5^{\circ}\text{C}$  higher than, ambient (room) temperature because of the internal heating zones sample chamber and other devices.

To check the box temperature functionality, we recommend checking the **BOX\_TEMP** signal voltage using the **SIGNAL I/O** function under the **DIAG** Menu (refer to Section 5.9.1).

At about  $30^{\circ}\text{C}$  ( $5^{\circ}$  above typical room temperature), the signal should be around 1500 mV. We recommend using a certified or calibrated external thermometer / temperature sensor to verify the accuracy of the box temperature.



### 10.5.19. PMT Temperature

PMT temperature should be low and constant. It is more important that this temperature is maintained constant than it is to maintain it low. The PMT cooler uses a Peltier, thermoelectric element powered by 12 VDC from the switching power supply PS2. The temperature is controlled by a proportional temperature controller located on the preamplifier board. Voltages applied to the cooler element vary from +/- 0.1 to +/- 12 VDC. The temperature set point (hard-wired into the preamplifier board) will vary by about  $\pm 1^\circ$  C due to component tolerances. The actual temperature will be maintained to within  $0.1^\circ$  C around that set point.

On power-up of the analyzer, the front panel enables the user to watch that temperature drop from about ambient temperature down to its set point of 6 to  $8^\circ$  C.

- If the temperature fails to drop after 20 minutes, there is a problem in the cooler circuit.
- If the control circuit on the preamplifier board is faulty, a temperature of  $-1^\circ$  C is reported.



## 10.6. Service Procedures

This section contains some procedures that may need to be performed when a major component of the analyzer requires repair or replacement.

### 10.6.1. Sensor Module Repair & Cleaning



**CAUTION - GENERAL SAFETY HAZARD**

Do not look at the UV lamp while the unit is operating. UV light can cause eye damage. Always use safety glasses made from UV blocking material when working with the UV Lamp Assembly. (Generic plastic glasses are not adequate).

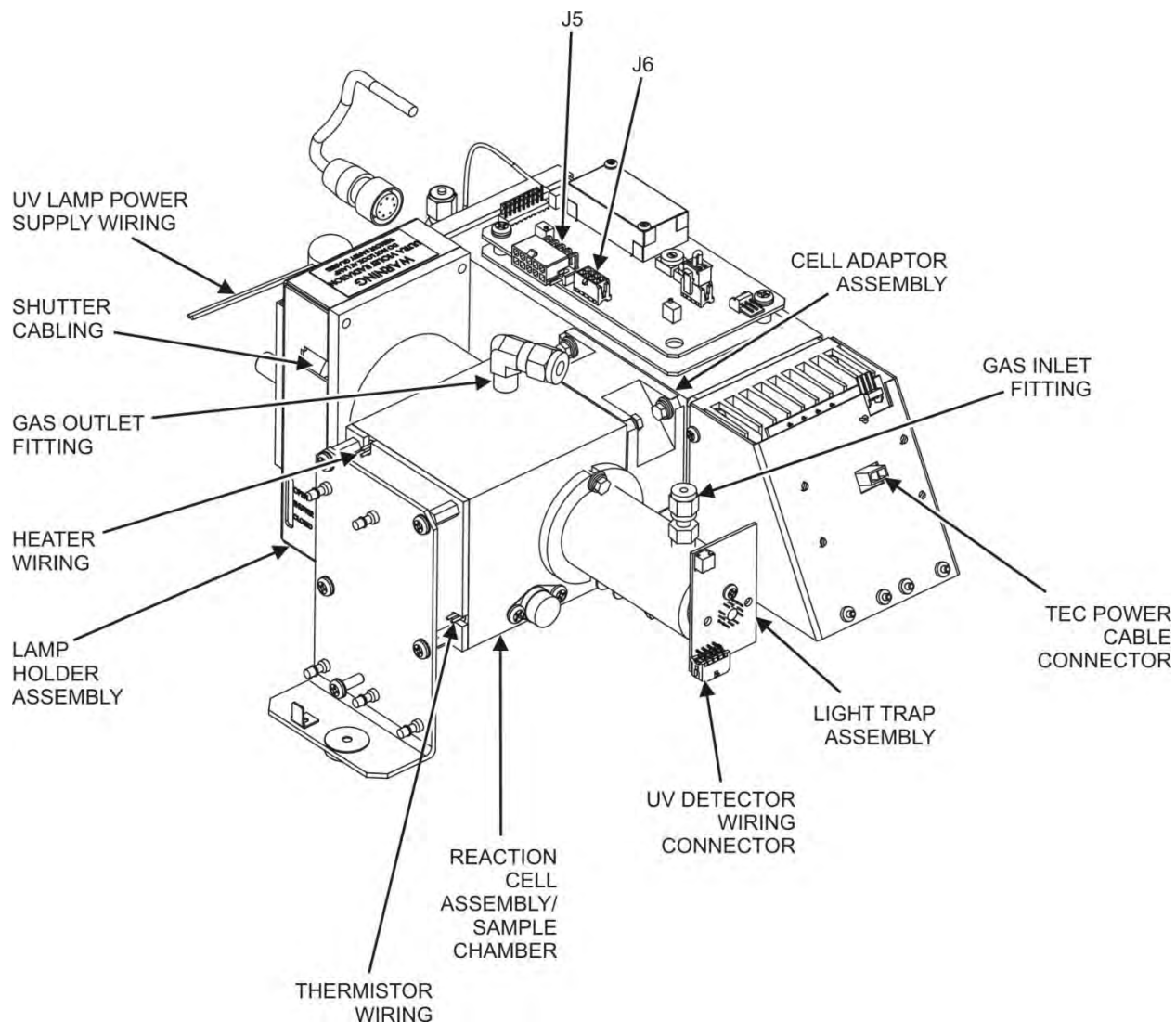

**Figure 10-5: Sensor Module Wiring and Pneumatic Fittings**

---

**IMPORTANT****IMPACT ON READINGS OR DATA**

**After any repair or service has been performed on the sensor module, the 6200T should be allowed to warm up for 60 minutes.**

**Always perform a leak check (refer to Section 9.3.6) and calibrate the analyzer (refer to Section 8.6) before placing it back in service.**

---

**10.6.1.1. Removing and Reinstalling the Sensor Module**

Several of the procedures in this section either require the sensor module to be removed from the instrument or are easier to perform if it has been removed.

To remove the Sensor Module:

1. Turn off the instrument power.
2. Open the top cover of the instrument:
  - Remove the set screw located in the top, center of the rear panel.
  - Remove the screws fastening the top cover to the unit (four per side).
  - Lift the cover straight up.
3. Disconnect the sensor module pneumatic lines (refer to Figure 10-5)
  - Gas inlet line: 1/8" black Teflon® line with stainless steel fitting.
  - Gas outlet line: 1/4" black Teflon® line with brass fitting.
4. Disconnect all electrical wiring to the Sensor Module:
  - UV lamp power supply wiring
  - Shutter cabling
  - Reaction cell thermistor wiring (yellow)
  - Reaction cell heater wiring (red)
  - UV detector wiring
  - TEC power cable
  - PMT wiring (connectors J5 & J6 on the PMT preamplifier PCA)
5. Remove the three sensor module mounting screws.



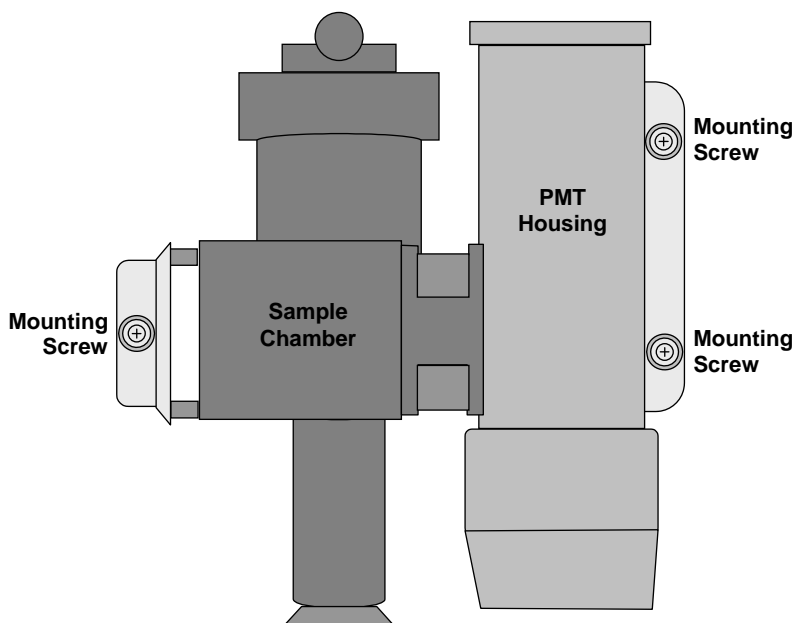

**Figure 10-6: Sensor Module Mounting Screws**

Follow the above steps in reverse order to reinstall the sensor module.

**10.6.1.2. Cleaning the Sample chamber**

**IMPORTANT**

**IMPACT ON READINGS OR DATA**

**The sample chamber should only be opened or cleaned on instructions from the Teledyne Analytical Instruments customer service department.**

**Be careful not to leave thumbprints on the interior of the sample chamber. The various oils that make up fingerprints fluoresce brightly under UV light and will significantly affect the accuracy of the analyzer’s SO<sub>2</sub> measurement)**

To clean the sample chamber:

1. Remove the sensor module as described in Section 10.6.1.1.
2. Remove the sample chamber mounting bracket by unscrewing the four bracket screws.

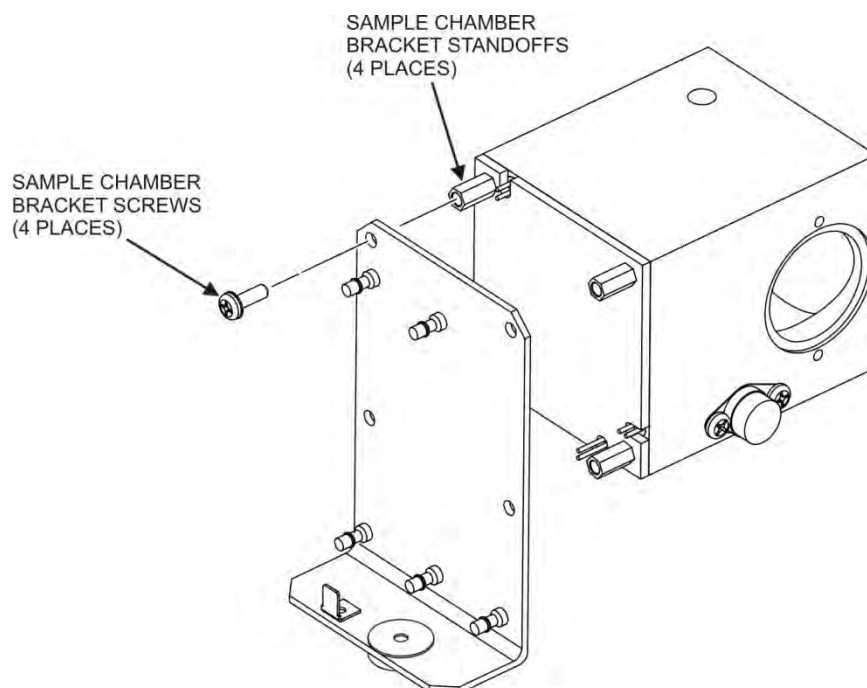

**Figure 10-7: Sample Chamber Mounting Bracket**

3. Unscrew the 4 hexagonal standoffs.
4. Gently remove the chamber cover.
5. Using a lint-free cloth dampened with distilled water, wipe the inside surface of the chamber and the chamber cover.
6. Dry the chamber surfaces with a 2nd lint-free cloth.
7. Re-assemble the chamber and re-install the sensor module.

### 10.6.1.3. Cleaning the PMT Lens and PMT filter

#### IMPORTANT

#### IMPACT ON READINGS OR DATA

The sample chamber should only be opened or cleaned on instructions from the Teledyne Analytical Instruments Customer Service Department.

Be careful not to leave thumbprints on the interior of the sample chamber. The various oils that make up fingerprints fluoresce brightly under UV light and will significantly affect the accuracy of the analyzer's SO<sub>2</sub> measurement).



To clean the PMT Lens and filter:

1. Remove the sensor module as described in Section 10.6.1.1.

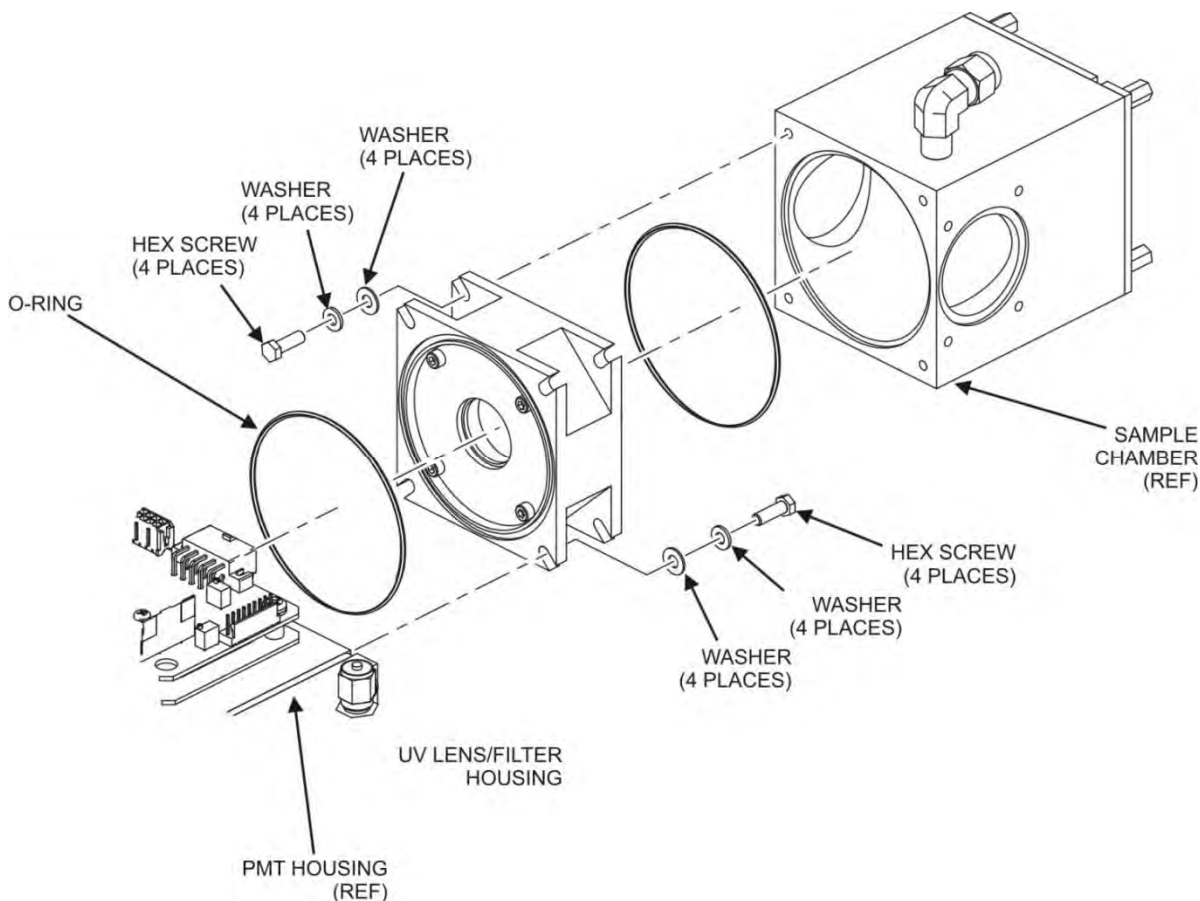

**Figure 10-8: Hex Screw Between Lens Housing and Sample Chamber**

2. Remove the sample chamber from the PMT lens and filter housing by unscrewing the 4 hex screws that fasten the chamber to the housing.
3. Remove the four lens cover screws.

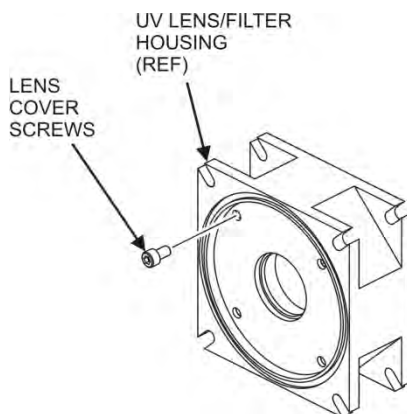

**Figure 10-9: UV Lens Housing / Filter Housing**

4. Remove the lens/filter cover.
5. Carefully remove the PMT lens and set it aside on soft, lint-free cloth.
6. Remove the 3-piece, lens/filter spacer.
7. Carefully remove the PMT filter and set it aside on soft, lint-free cloth.

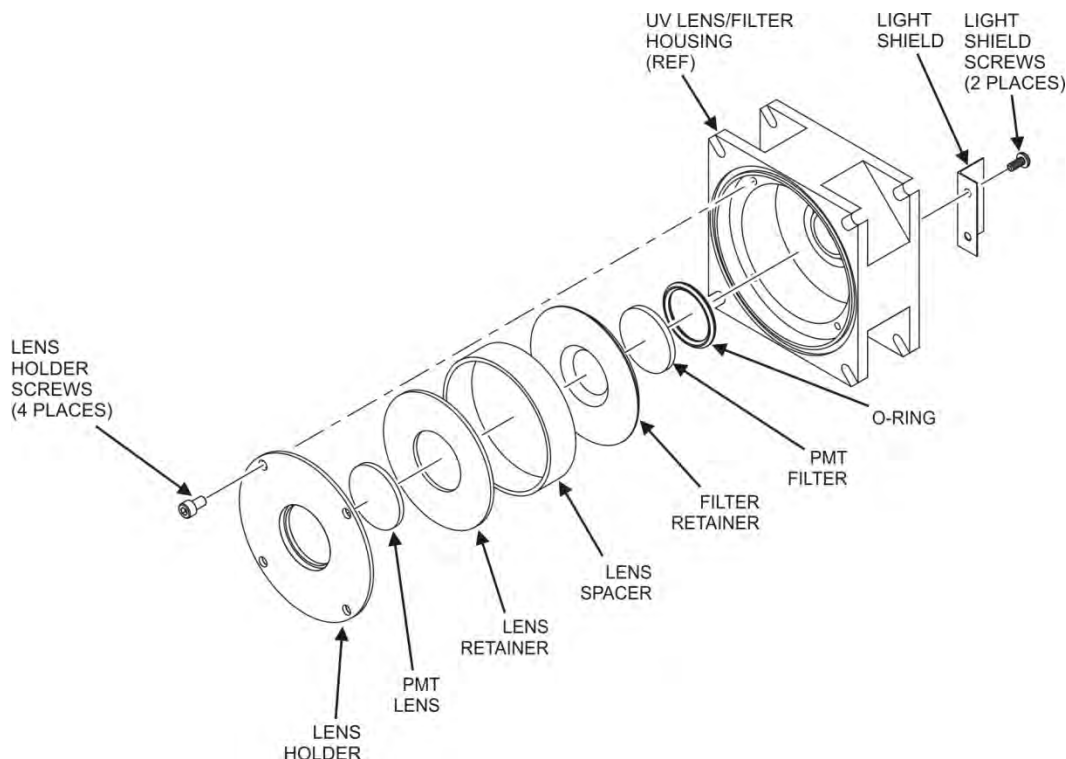

**Figure 10-10: PMT UV Filter Housing Disassembled**

8. Using a lint-free cloth dampened with distilled water, clean the lens, the filter and all of the housing assembly mechanical parts.
9. Dry everything with a 2nd lint-free cloth.
10. Reassemble the lens/filter housing (refer to
11. Figure 10-10 and Figure 10-9).

**IMPORTANT**

**IMPACT ON READINGS OR DATA**

**Use gloves and a clean plastic covered surface during assembly. Cleanliness of the inside of the light shield, the UV lens filter housing and the PMT lens is especially important.**

**Note**

**Apply Loctite to the four lens holder screws and the two light shield screws.**





12. Reattach the lens / filter housing to the sample chamber.
13. Reattach the sample chamber to the PMT housing.
14. Reinstall the sensor module into the 6200T.
15. Close the instrument.
16. Turn the 6200T on and let it warm up for 60 minutes.
17. Perform a leak check (refer to Section 9.3.6).
18. Calibrate the analyzer (refer to Sections 3 and 5).

**10.6.1.4. Replacing the UV filter/lens**

**IMPORTANT**

**IMPACT ON READINGS OR DATA**

**Be careful not to leave thumbprints on the interior of the sample chamber. The various oils that make up fingerprints fluoresce brightly under UV light and will significantly affect the accuracy of the analyzer’s SO<sub>2</sub> measurement).**

**CAUTION - GENERAL SAFETY HAZARD**



**Do not look at the UV lamp while the unit is operating. UV light can cause eye damage. Always use safety glasses made from UV blocking material when working with the UV Lamp Assembly. (Generic plastic glasses are not adequate).**

To replace the UV filter lens:

1. Turn off the instrument’s power and remove the power cord from the instrument.
2. Unplug J4 connector from the motherboard to allow tool access.
3. Alternatively, remove the sensor module as described in Section 10.6.1.1.
4. Remove 4 screws from the shutter cover (refer to Figure 10-12) and remove the cover.
5. Remove 4 screws from the UV filter retainer.

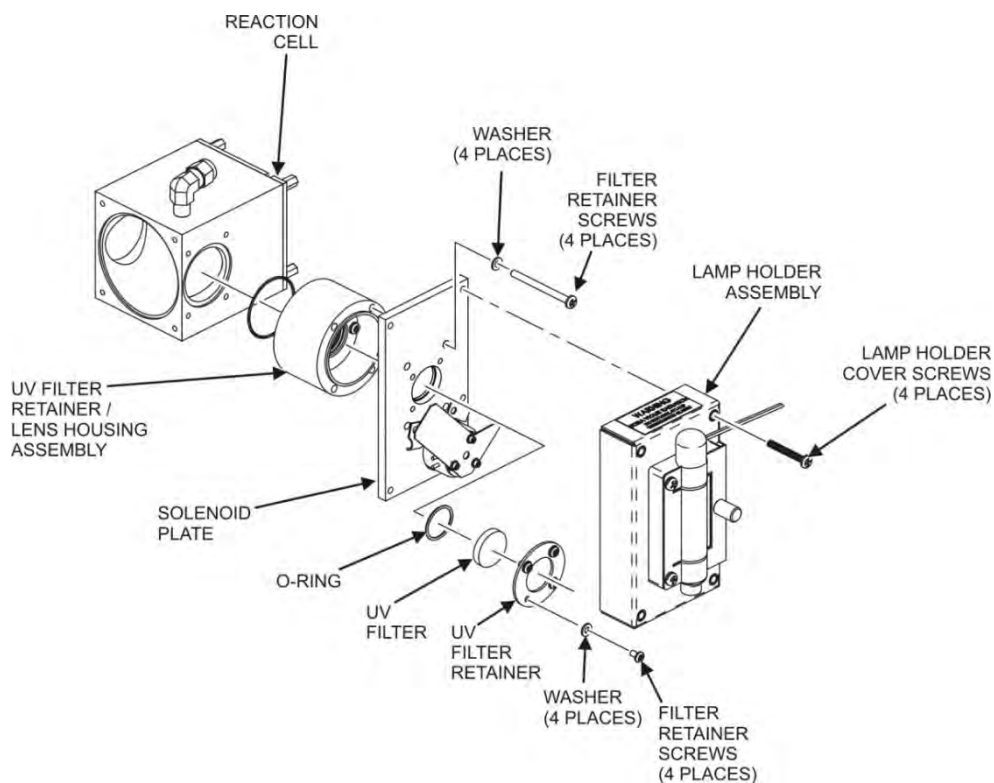

**Figure 10-11: Disassembling the Shutter Assembly**

6. Carefully remove the UV filter.
7. Install the UV filter.
8. Handle carefully and never touch the filter's surface.
9. UV filter's wider ring side should be facing out.
10. Install UV filter retainer and tighten screws.
11. Install the shutter cover and minifit connector. Tighten 4 shutter cover screws.
12. Reinstall the sensor module and Plug J4 connector into the motherboard.

#### 10.6.1.5. Adjusting the UV Lamp (*Peaking the Lamp*)

There are three ways in which ambient conditions can affect the UV Lamp output and therefore the accuracy of the SO<sub>2</sub> concentration measurement. These are:

**Line Voltage Change:** UV lamp energy is directly proportional to the line voltage. This can be avoided by installing adequate AC Line conditioning equipment such as a UPS/surge suppressor.

**Lamp Aging** - Over a period of months, the UV energy will show a downward trend and can be up to 50% in the first 90 days, and then a slower rate, until the end of useful life of the lamp. Periodically running the UV lamp calibration routine (refer to Section 5.9.6) will compensate for this until the lamp output becomes too low to function at all.

#### Note

**As the lamp degrades over time, the software for the CPU compensates for the loss of UV output.**



**Lamp Positioning** – The UV output level of the lamp is not even across the entire length of the lamp. Some portions of the lamp shine slightly more brightly than others. At the factory the position of the UV lamp is adjusted to optimize the amount of UV light shining through the UV filter/lens and into the reaction cell. Changes to the physical alignment of the lamp can affect the analyzers ability to accurately measure SO<sub>2</sub>.

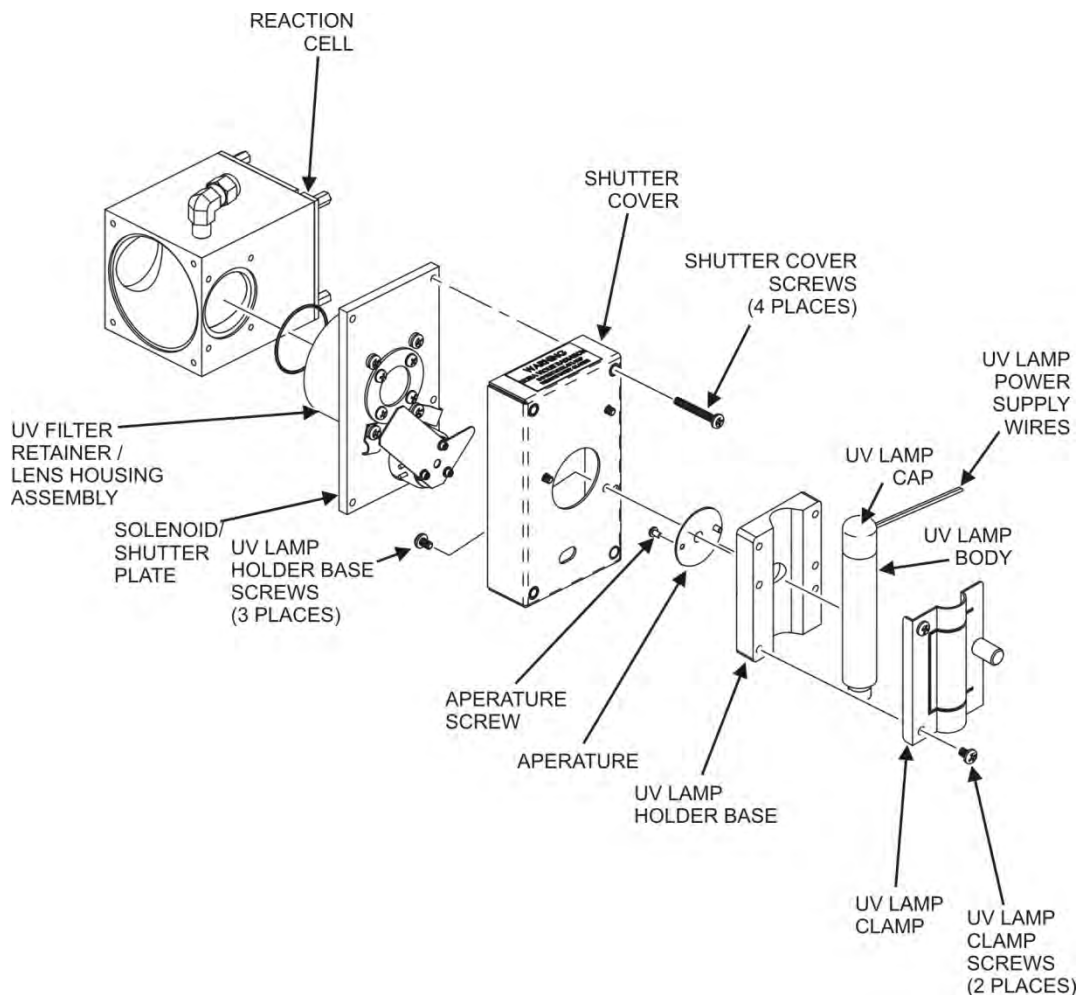

Figure 10-12: Shutter Assembly



**CAUTION - GENERAL SAFETY HAZARD**

Do not look at the UV lamp while the unit is operating. UV light can cause eye damage. Always use safety glasses made from UV blocking material when working with the UV Lamp Assembly. (Generic plastic glasses are not adequate).

1. Set the analyzer display to show the signal I/O function, **UVLAMP\_SIGNAL** (refer to Section 10.1.3). **UVLAMP\_SIGNAL** is function 33.
2. Slightly loosen the large brass thumbscrew located on the shutter housing (refer to Figure 10-13) so that the lamp can be moved.

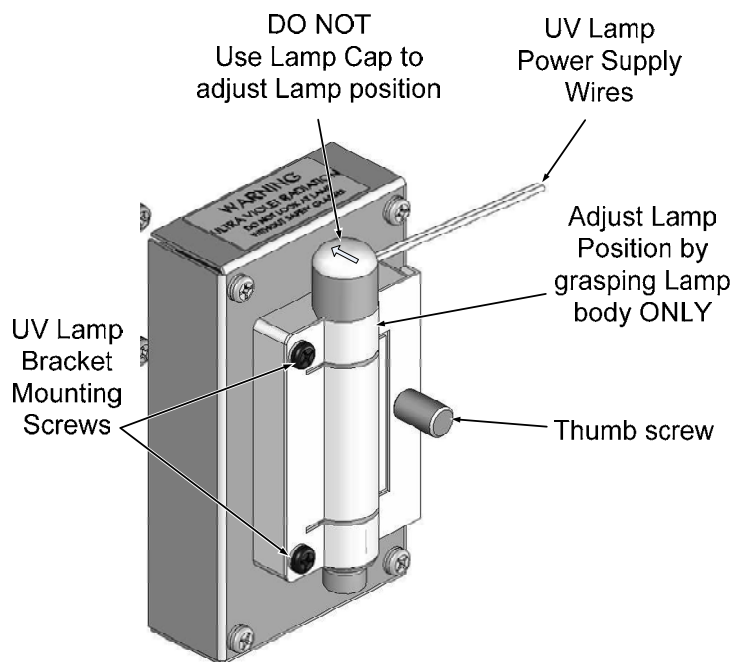

Figure 10-13. UV Lamp Adjustment

**ATTENTION**

**COULD DAMAGE INSTRUMENT AND VOID WARRANTY**

**DO NOT** grasp the UV lamp by its cap when changing its position - always grasp the main body of the lamp (refer to Figure 10-12). Inattention to this detail could twist and potentially disconnect the lamp's power supply wires.

3. While watching the **UVLAMP\_SIGNAL** reading, slowly rotate the lamp or move it back and forth vertically until the **UVLAMP\_SIGNAL** reading is at its maximum.
4. Compare the **UVLAMP\_SIGNAL** reading to the information in Table 10-9 and follow the instructions there.

Table 10-9: UV Lamp Signal Troubleshooting

UVLAMP_SIGNAL	ACTION TO BE TAKEN
3500mV±200mV.	No Action Required
> 4900mV at any time.	Adjust the UV reference detector potentiometer ( Figure 10-14) until <b>UVLAMP_SIGNAL</b> reads approximately 3600mV before continuing to adjust the lamp position.
>3700mV or < 3300mV	Adjust the UV reference detector potentiometer ( Figure 10-14) until <b>UVLAMP_SIGNAL</b> reads as close to 3500mV as possible.
< 600mV	Replace the lamp (Section 10.6.1.6.



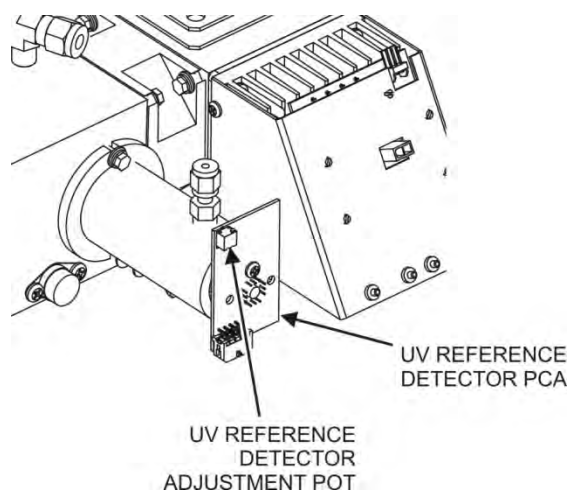

**Figure 10-14: Location of UV Reference Detector Potentiometer**

5. Finger tighten the thumbscrew.



**CAUTION - GENERAL SAFETY HAZARD**

**DO NOT** over tighten the thumbscrew, as over-tightening can cause breakage to the lamp and consequently release mercury into the area.

**10.6.1.6. Replacing the UV Lamp**



**CAUTION - GENERAL SAFETY HAZARD**

**Do not look at the UV lamp while the unit is operating. UV light can cause eye damage. Always use safety glasses made from UV blocking material when working with the UV Lamp Assembly. (Generic plastic glasses are not adequate).**

1. Turn off the analyzer.
2. Disconnect the UV lamp from its power supply.
3. You can find the power supply connector by following the two, white UV Lamp power supply wires from the lamp to the power supply.
4. Loosen, but do not remove the two UV lamp bracket screws and the large brass thumbscrew located (refer to Figure 10-12 and Figure 10-13) on the shutter housing so that the lamp can be moved.

**ATTENTION**

**-----  
COULD DAMAGE INSTRUMENT AND VOID WARRANTY**

**DO NOT** grasp the UV lamp by its cap when changing its position - always grasp the main body of the lamp (refer to Figure 10-12) Inattention to this detail could twist and potentially disconnect the lamp's power supply wires.

**-----**

5. Remove the UV Lamp by pulling it straight up.
6. Insert the new UV lamp into the bracket.
7. Tighten the two UV lamp bracket screws, but leave the brass thumb screw un-tightened.
8. Connect the new UV lamp to the power supply.
9. Turn the instrument on and perform the UV adjustment procedure as defined in section 10.6.1.5.
10. Finger tighten the thumbscrew.

**CAUTION - GENERAL SAFETY HAZARD**

**DO NOT over tighten the thumbscrew, as over-tightening can cause breakage to the lamp and consequently release mercury into the area.**

11. Perform a lamp calibration procedure (refer to Section 5.9.6) and a zero point and span point calibration (refer to Sections 3 and 5).

**10.6.1.7. Replacing the PMT, HVPS or TEC**

The PMT should last for the lifetime of the analyzer. However, in some cases, the high voltage power supply (HVPS) or the thermo-electric cooler (TEC) may fail.

**IMPORTANT**

-----  
**When removing the PMT housing end plate cover for the Sensor Assembly, ensure to replace the 5 desiccant bags inside the housing.**  
-----



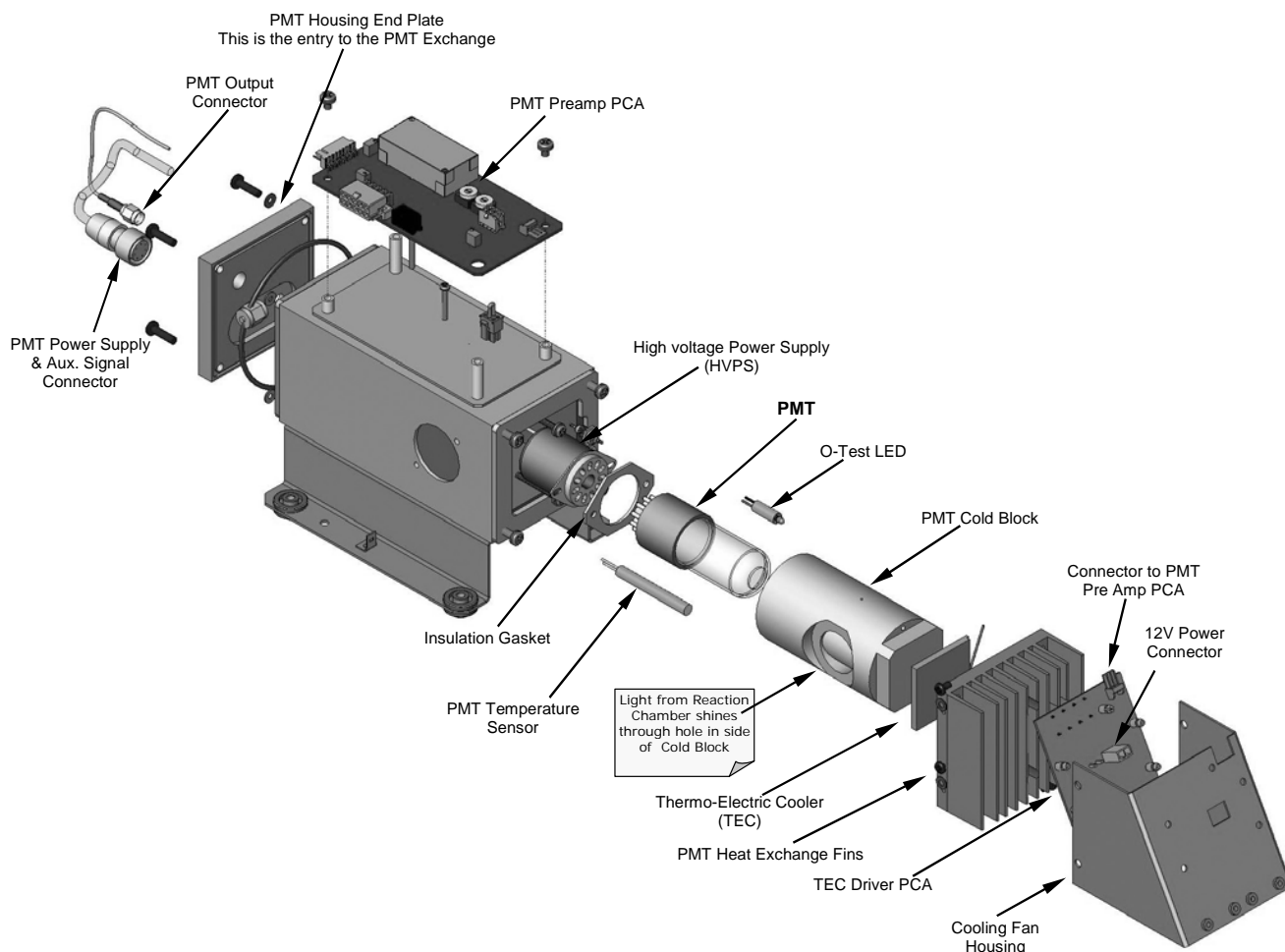

**Figure 10-15: PMT Assembly - Exploded View**

To replace the PMT, the HVPS or the TEC:

1. Remove the sensor module as described in Section 10.6.1.1.
2. Remove the entire sensor module assembly from the.
3. Remove the reaction cell assembly.
4. Remove the two connectors on the PMT housing end plate facing towards the front panel.
5. Remove the end plate itself (4 screws with plastic washers).
6. Remove the desiccant bags inside the PMT housing.
7. Along with the plate, slide out the OPTIC TEST LED and the thermistor that measures the PMT temperature.
  - Both may be coated with a white, thermal conducting paste. Do not contaminate the inside of the housing or the PMT tube with this grease.
8. Unscrew the PMT assembly. It is held to the cold block by two plastic screws.
  - Because the threads of the plastic screws are easily damaged it is highly recommended to use new screws when reassembling the unit.
9. Carefully take out the assembly consisting of the HVPS, the gasket and the PMT.

10. Change the PMT or the HVPS or both, clean the PMT glass tube with a clean, anti-static wipe and **DO NOT TOUCH** it after cleaning.
11. If the cold block or TEC is to be changed disconnect the TEC driver board from the preamplifier board.
  - Remove the cooler fan duct (4 screws on its side) including the driver board.
  - Disconnect the driver board from the TEC and set the sub-assembly aside.
  - Remove the end plate with the cooling fins (4 screws) and slide out the PMT cold block assembly, which contains the TEC.
  - Unscrew the TEC from the cooling fins and the cold block and replace it with a new unit.
12. Re-assemble the TEC subassembly in reverse order.

**ATTENTION**

---

**COULD DAMAGE INSTRUMENT AND VOID WARRANTY**

**The thermo-electric cooler needs to be mounted flat to the heat sink. If there is any significant gap, the TEC might burn out. Ensure to apply heat sink paste before mounting it and tighten the screws evenly and cross-wise.**

---

- Ensure to use thermal grease between TEC and cooling fins as well as between TEC and cold block.
  - Align the side opening in the cold block with the hole in the PMT housing where the sample Chamber attaches.
  - Evenly tighten the long mounting screws for good thermal conductivity.
13. Re-insert the TEC subassembly. Ensure that the O-ring is placed properly and the assembly is tightened evenly.
  14. Re-insert the PMT/HVPS subassembly.
    - Don't forget the gasket between HVPS and PMT.
    - Use new plastic screws to mount the PMT assembly on the PMT cold block.
  15. Insert the LED and thermistor into the cold block.
  16. Replace the desiccant bags with five new desiccant bags.
  17. Carefully replace the end plate.
    - Ensure that the O-ring is properly in place. Improperly placed O-rings will cause leaks, which – in turn – cause moisture to condense on the inside of the cooler causing the HVPS to short out.
  18. Reconnect the cables and the reaction cell
    - Be sure to tighten these screws evenly.
  19. Replace the sensor assembly into the chassis and fasten with four screws and washers.
  20. Perform a leak check the system.





21. Power up the analyzer and verify the basic operation of the analyzer using the ETEST and OTEST features (refer to Section 5.9.4) or by measuring calibrated zero and span gases.
22. Allow the instrument to warm up for 60 minutes.
23. Perform a PMT Hardware calibration (refer to Section 10.6.1.8).
24. Perform a zero point and span calibration (refer to Section 5).

**10.6.1.8. PMT Hardware Calibration (*Factory Cal*)**

The sensor module hardware calibration adjusts the slope of the PMT output when the instrument’s slope and offset values are outside of the acceptable range and all other more obvious causes for this problem have been eliminated.

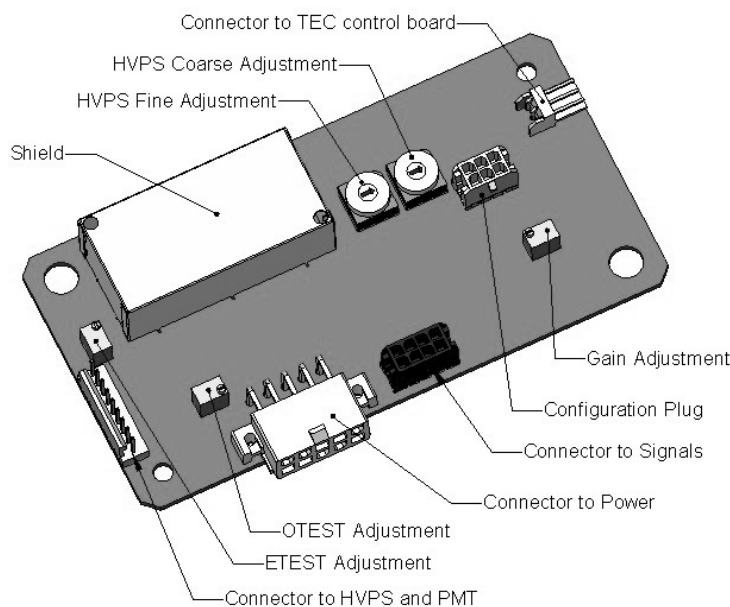

**Figure 10-16: Pre-Amplifier Board (Preamp PCA) Layout**

1. Set the instrument reporting range type to **SNGL** (refer to Section **Error! Reference source not found.**).
2. Perform a zero–point calibration using zero air (refer to Section 8.6).
3. Let the instrument stabilize by allowing it to run for one hour.
4. Adjust the UV Lamp (refer to Section 10.6.1.5).
5. Perform a **LAMP CALIBRATION** procedure (refer to Section 5.9.6).
6. Locate the Preamp PCA (refer to Figure 10-15).
7. Locate the Following Components On the Preamp PCA (Figure 10-16).

Figure 10-16::

- HVPS coarse adjustment switch (Range 0-9, then A-F).
- HVPS fine adjustment switch (Range 0-9, then A-F).
- Gain adjustment potentiometer (Full scale is 10 to 12 turns).

8. Set the HVPS coarse adjustment to its minimum setting (0).
9. Set the HVPS fine adjustment switch to its maximum setting (F).
10. Turn the gain adjustment potentiometer clockwise to its maximum setting.
11. Set the front panel display to show stabil (refer to Section 4.1.1).
12. Feed span gas into the analyzer.
13. Wait until the **STABIL** value is below 0.5 ppb.

**IMPORTANT**-----  
**IMPACT ON READINGS OR DATA**

**Use a span gas equal to 80% of the reporting range.  
Example: for a reporting range of 500 ppb, use a span gas of 400 ppb.**

14. Scroll to the **OFFSET** function and record the value.
15. Scroll to the **NORM PMT** value.

**ATTENTION**-----  
**COULD DAMAGE INSTRUMENT AND VOID WARRANTY**

**Do not overload the PMT by accidentally setting both adjustment switches to their maximum setting. This can cause permanent damage to the PMT.**

16. Determine the target **NORM PMT** value according to the following formulas.
  - If the reporting range is set for  $\leq 2,000$  ppb (the instrument will be using the 2,000 ppb physical range):  
Target **NORM PMT** = (2 x span gas concentration) + **OFFSET**
  - If the reporting range is set for  $\geq 2,001$  ppb (the instrument will be using the 20,000 ppb physical range):  
Target **NORM PMT** = (0.181 x span gas concentration) + **OFFSET**

**EXAMPLE:** If the **OFFSET** IS 33 mV, the Reporting Range is 500 ppb, the span gas should be 400 ppb and the calculation would be:  
Target **NORM PMT** = (2 x 400) + 33 mV  
Target **NORM PMT** = 833 mV
17. Set the HVPS coarse adjustment switch to the lowest setting that will give you more than the target **NORM PMT** signal from Step 16.
  - The coarse adjustment typically increments the **NORM PMT** signal in 100-300 mV steps.
18. Adjust the HVPS fine adjustment such that the **NORM PMT** value is at or just above the target **NORM PMT** signal from Step 16.
19. Continue adjusting the both the coarse and fine switches until norm PMT is as close to (but not below) the target **NORM PMT** signal from Step 16.
20. Adjust gain adjustment potentiometer until the **NORM PMT** value is  $\pm 10$  mV of the target level from Step 16.



21. Perform span and zero-point calibrations (refer to Section 8.6) to normalize the sensor response to its new PMT sensitivity.
22. Review the slope and offset values, and compare them to the values in Table 8-9.

## 10.7. M501TS Converter Maintenance

Maintenance on the M501TS Thermal Converter includes:

- Changing the Quartz Tube
- Checking the Converter Efficiency
- Sample Diluter Maintenance
- Replacing a Thermocouple.

### 10.7.1. Changing the Quartz Tube

1. Turn off M501TS and allow it to cool to room temperature (~2 hours).
2. See below Figure, 501TS Layout.

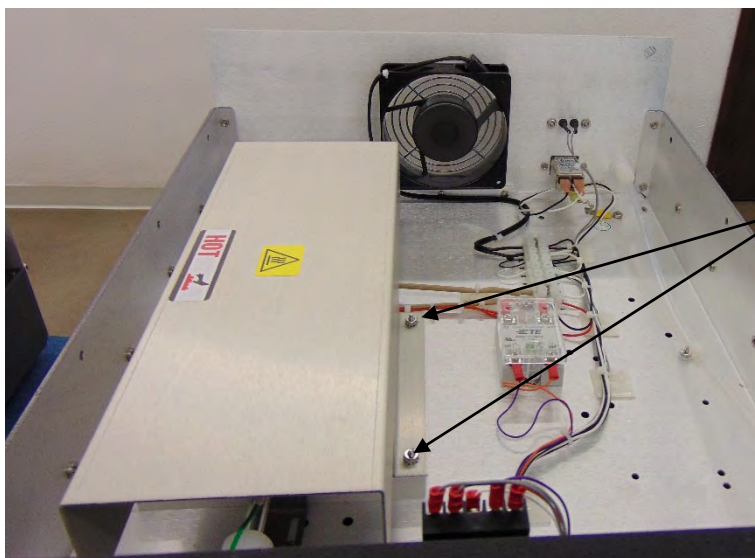

Unscrew the (3) nuts that secure the inner cover protecting the Heater Block and quartz tube. Remove this cover.

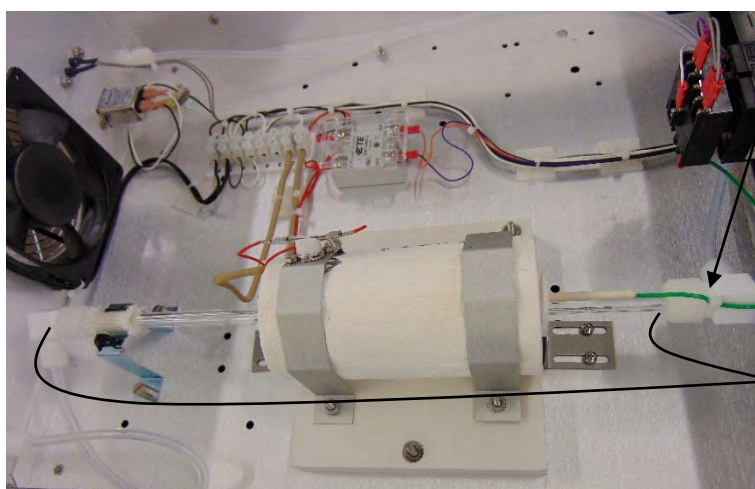

Cut the tie-wrap that secures the thermocouple to the fitting at the end of the quartz

Loosen the Teflon fitting at the end of the quartz tube taking care not to put any stress on the tube and slide the fitting off the tube.

**Figure: 10-17: 501TS, Quartz Tube Replacement Procedure**

3. Remove the screws from the top inside of the front panel and fold panel downward.
4. Loosen front and rear fittings at each end of the tube.
5. Carefully slide the tube out of the heater – the ceramic bushings at each end of the heater are very fragile.



6. Slide the new tube into the heater and re-connect the fittings.
7. Leak check the unit.
8. Replace the thermocouple making sure that it is fully inserted into the indentation in the body of the quartz tube.
9. Check the converter efficiency. See the Section below.

### 10.7.2. Checking the Converter Efficiency

After maintenance it is good practice to check the converter efficiency. To check the converter efficiency, perform the following procedure:

1. Produce a calibration gas of 400 ppb H<sub>2</sub>S in CO<sub>2</sub> at a flow greater than the demand of the instrument; vent the excess gas out of the room.
  - When using a calibrator or gas blender to generate H<sub>2</sub>S span gas (either permeation tube or tank) with CO<sub>2</sub> gas as the diluent, please remember that rotameters and mass flow controllers are calibrated with air or nitrogen. Using them with CO<sub>2</sub> will produce large calibration errors (as large as 30% or more), since CO<sub>2</sub> gas has considerably different characteristics. Contact the manufacturer of your mass flow measurement/control device for instructions on how to use it to measure CO<sub>2</sub> flow. Or use a flowmeter such as a soap bubble, or BIOS – DryCal flowmeter that measures volume flow.
2. Allow the 6200T to stabilize at span for at least 30 minutes.
3. Check the converter efficiency by adjusting the converter's temperature controller set point:
  - Starting at the converters normal set-point of 1000°C, lower the set-point temperature of the Converter in 5°C increments (allowing 10 minutes minimum settling time between increments) until a drop of approximately 5% of Full Scale is observed. Note the Thermal Converter temperature at this point.
  - Verify that the converter efficiency does not drop by 5% until the temperature has dropped by at least 40°C,
  - Return the temperature set point to 1000°C.



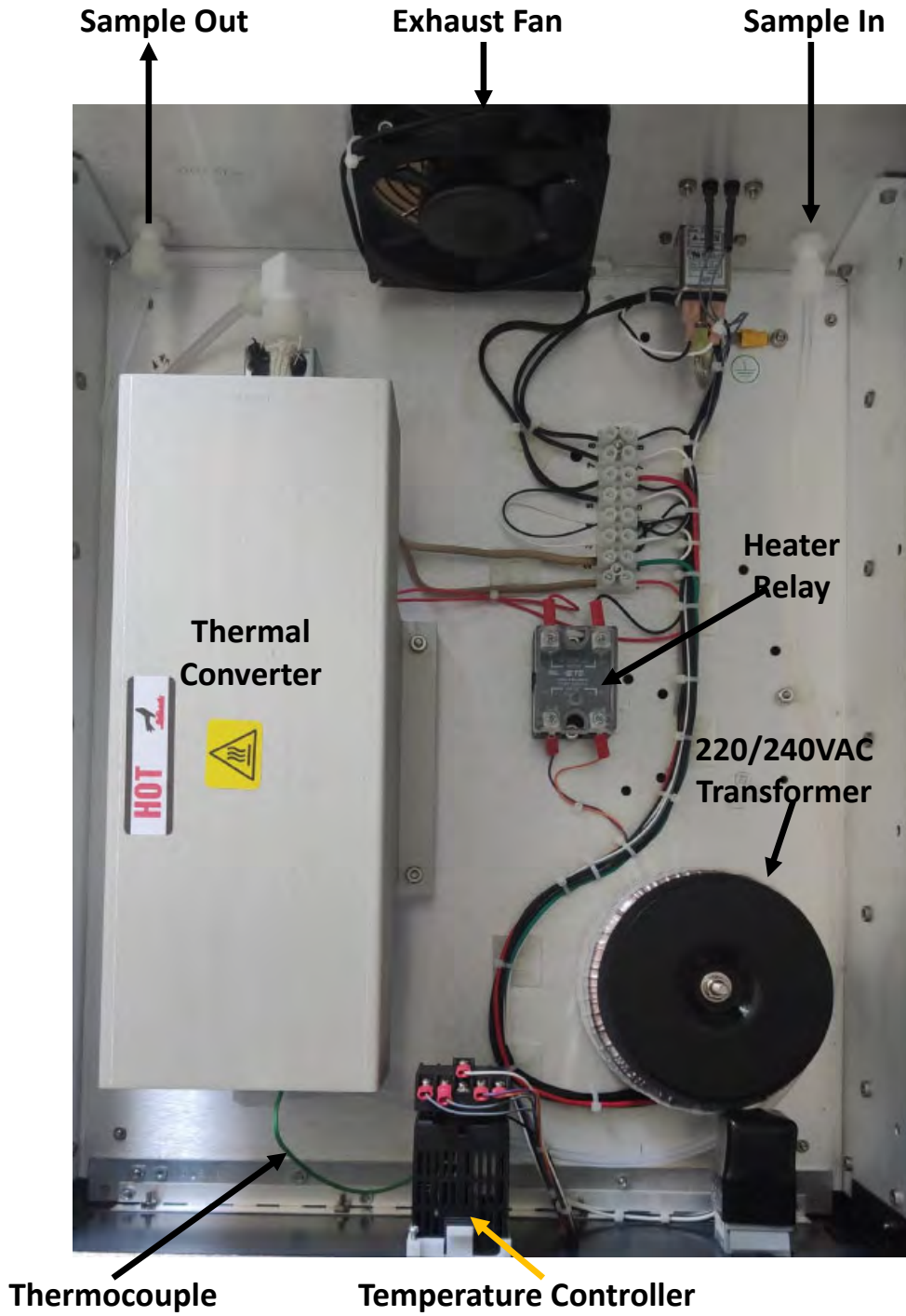

Figure 10-18: 501TS, Internal Layout of Converter(220VAC Version)



### 10.7.3. Sample Diluter Maintenance

The sample diluter is used to inject a small amount of ambient air into the sample stream to provide oxygen for the converter. The diluter is located on the inside rear panel of the SO<sub>2</sub> analyzer. It consists of a stainless steel block and 2 orifices to control the amount of sample and air that is blended.

There should be no periodic maintenance required on this assembly, but a diagram is included in case rebuilding of this assembly is required. The assembly is shown in Figure 10-18.

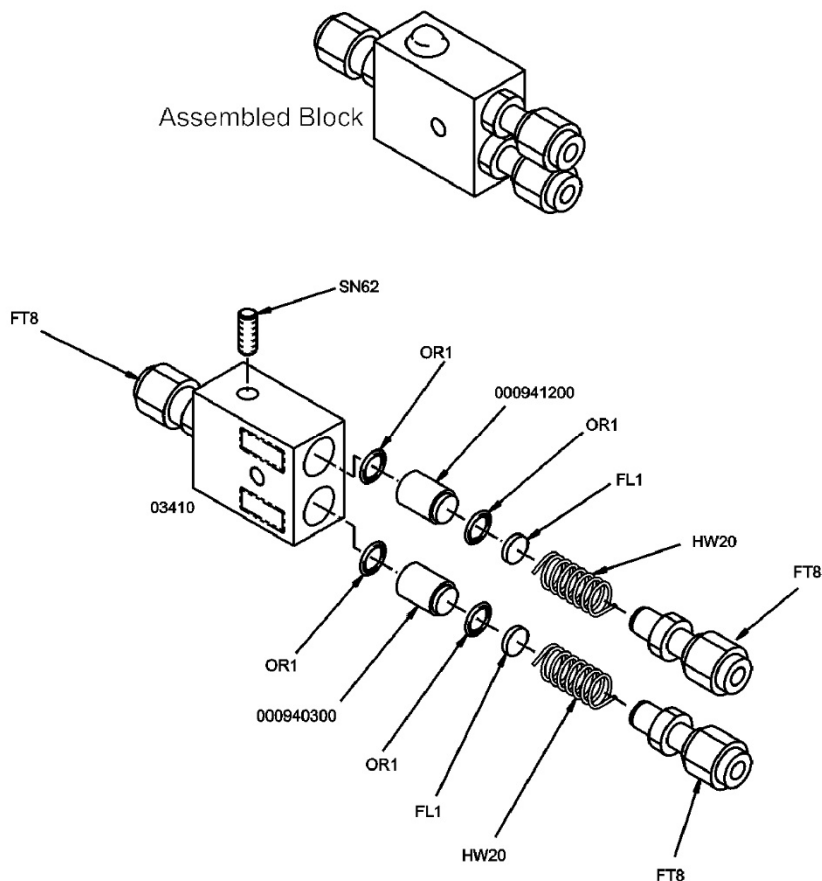

Figure 10-19: Diluter Flow Block Assembly

### 10.7.4. Thermocouple Replacement

Continuous operation at 1000 °C will eventually degrade the performance of the thermocouple used to sense the temperature of the quartz oven. The following instructions describe how to install a new thermocouple into the Converter Heater Block. This is a replacement thermocouple (KIT000255). The following instructions provide the necessary information to remove the existing thermocouple and replace it with the new one supplied in Kit 255.

You will need the following tools:

- Nutdriver, 5/16
- Nutdriver, 11/32
- Diagonal Cutter
- Philips head Screwdriver #2

Once you have the right tools and parts, replace the thermocouple as follows:

1. Ensure power is removed from the M501TS Converter. If the Converter has been operational you will need to wait for 2 hours for the Converter oven to cool before continuing with the replacement of the thermocouple.
2. Remove the cover from the Converter chassis.
3. Unscrew the (4) nuts that secure the front panel to the chassis. They are located just behind the Front Panel along the top.
4. Lower the Front Panel to gain easier access to the end of the quartz tube.
5. Unscrew the (3) nuts that secure the inner cover protecting the Heater Block and quartz tube. Remove this cover.
6. Cut the tie-wrap that secures the thermocouple to the fitting at the end of the quartz tube.
7. Loosen the Teflon fitting at the end of the quartz tube taking care not to put any stress on the tube and slide the fitting off the tube.
8. Remove the thermocouple.
9. Disconnect the thermocouple wires from the Temperature Controller. Figure 2.5

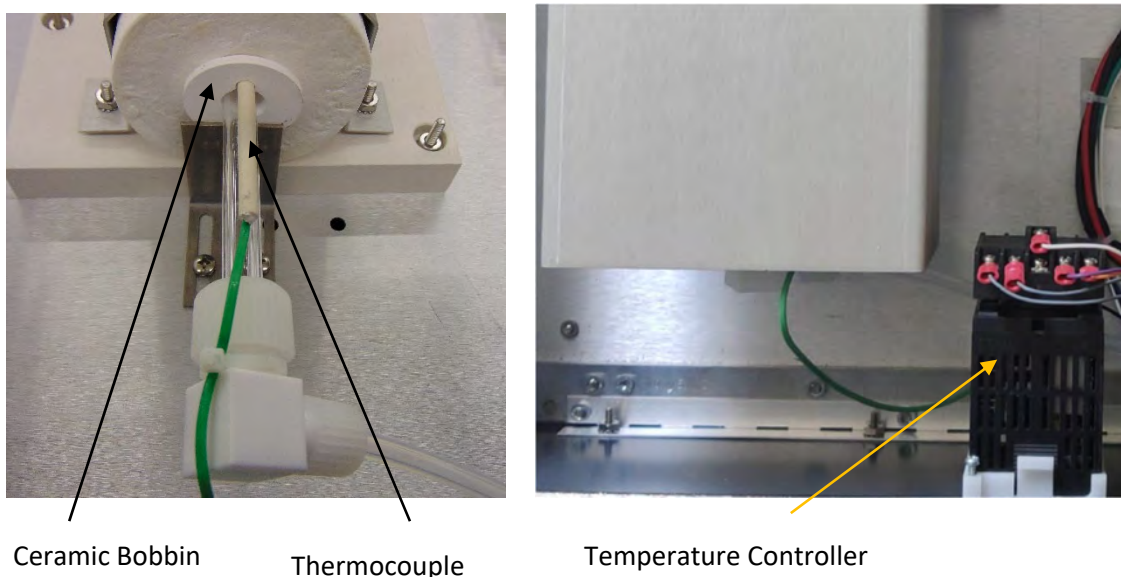
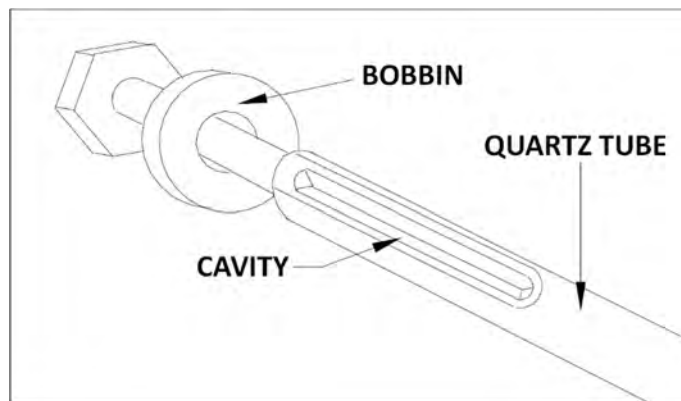

**Figure: 10-20: 501TS, Thermocouple & Temperature Controller Location**





10. In preparation for installing the new thermocouple, look into the end of the Heater Block. You will see that there is an indentation (cavity) in the fat part of the quartz tube. This is where the thermocouple you are installing will reside.



**Figure: 10-21: 501TS, Quartz Tube Cavity for Thermocouple**

11. The thermocouple should slide into the Heater Block and into the indentation of the quartz.
12. Align the thermocouple with this cavity and carefully push the thermocouple all the way into the cavity until it comes to a stop, which is the end of the cavity of the quartz tube.
13. The thermocouple should now be properly seated in the cavity of the quartz tube. Refer to Figure 2.7

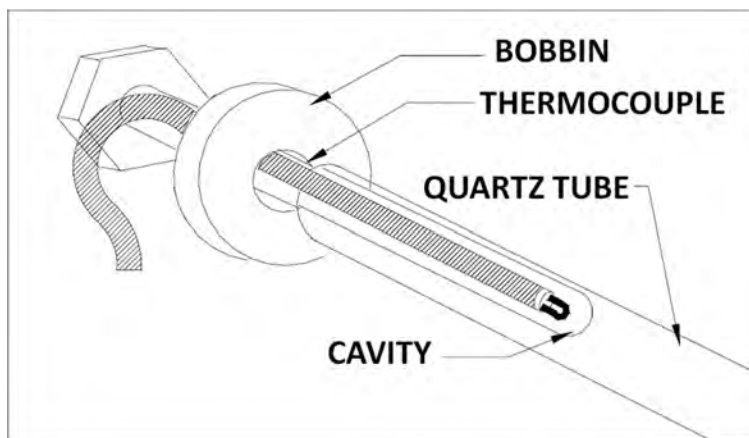
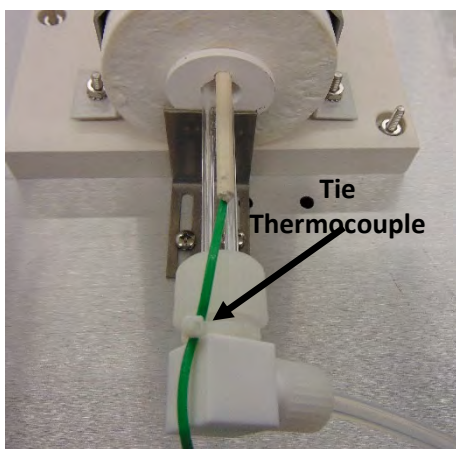

**Figure: 10-22: 501TS, Thermocouple Installation Procedure**

14. Reconnect the Teflon fitting that was removed earlier from the end of the quartz tube. Take care not to put any stress on the quartz tube as the Teflon fitting is tightened.
15. Form the Thermocouple wire so that it rests in the cavity with little movement.
16. Connect the (2) wires of the thermocouple to the Temperature Controller. The Black wire should be connected to Pin 1 and the Red wire should be connected to Pin 2. (If the wires are of any other colour, STOP. Get the correct part from TAI Sales or call Customer Service).

## 10.8. Frequently Asked Questions (FAQs)

The following list contains some of the most commonly asked questions relating to the 6200T,TS Analyzer.

QUESTION	ANSWER
Why is the <b>ZERO</b> or <b>SPAN</b> button not displayed during calibration?	The 6200T disables these buttons when the expected span or zero value entered by the users is too different from the gas concentration actually measured value at the time. This is to prevent the accidental recalibration of the analyzer to an out-of-range response curve.-EXAMPLE: The span set point is 400 ppb but gas concentration being measured is only 50 ppb.-For more information, refer to Section 10.3.4 and Section 10.3.5.
Why does the <b>ENTR</b> button sometimes disappear on the Front Panel Display?	During certain types of adjustments or configuration operations, the <b>ENTR</b> button will disappear if you select a setting that is nonsensical (such as trying to set the 24-hour clock to 25:00:00) or out of the allowable range for that parameter (such as selecting a DAS hold off period of more than 20 minutes).- Once you adjust the setting in question to an allowable value, the <b>ENTR</b> button will re-appear.
How do I enter or change the value of my Span Gas?	Press the <b>CONC</b> button found under the <b>CAL</b> or <b>CALS</b> menus of the main SAMPLE menu to enter the expected SO <sub>2</sub> span concentration.-Refer to Section 3.4.4.1 or for more information.
Why does the analyzer not respond to span gas?	Section 10.3.4 has some possible answers to this question.
Can I automate the calibration of my analyzer?	Any analyzer with zero/span valve or IZS option can be automatically calibrated using the instrument's AutoCal feature.-However, the accuracy of the IZS option's permeation tube is $\pm 5\%$ . While this may be acceptable for basic calibration checks, the IZS option is not permitted as a calibration source in applications following US EPA protocols. -To achieve highest accuracy, it is recommended to use cylinders of calibrated span gases in combination with a zero air source. Teledyne Analytical Instruments offers a zero air generator Model 701 and a gas dilution calibrator Model T700 for this purpose.
What do I do if the concentration on the instrument's front panel display does not match the value recorded or displayed on my data logger even if both instruments are properly calibrated?	This most commonly occurs for one of the following reasons: -A difference in circuit ground between the analyzer and the data logger or a wiring problem;-A scale problem with the input to the data logger. -The analog outputs of the 6200T can be manually adjusted to compensate for either or both of these effects, refer to <b>Error! Reference source not found.</b> ; -The analog outputs are not calibrated, which can happen after a firmware upgrade. -Both the electronic scale and offset of the analog outputs can be adjusted (refer to Section <b>Error! Reference source not found.</b> ). Alternately, use the data logger itself as the metering device during calibrations procedures.
How do I perform a leak check?	Refer to Section 9.3.6.
How do I measure the sample flow?	Sample flow is measured by attaching a calibrated flow meter to the sample inlet port when the instrument is operating. The sample flow should be 650



QUESTION	ANSWER
	cm <sup>3</sup> /min ±10%. Section 9.3.6 includes detailed instructions on performing a check of the sample gas flow.
How often do I need to change the particulate filter?	Once per week. Table 9-1 contains a maintenance schedule listing the most important, regular maintenance tasks.
What is the averaging time for an 6200T?	The default averaging time, optimized for ambient pollution monitoring, is 240 seconds for stable concentrations and 20 seconds for rapidly changing concentrations; Refer to 11.5.1 for more information.
My analyzer has the optional, user - configurable analog output channels. How do I program and use them?	Instructions for this can be found in the Manual Addendum for Configurable Analog Output, PN 06270.
How long does the sample pump last?	The sample pump should last about one year and the pump diaphragms should to be replaced annually or when necessary. Use the <b>PRES</b> test function displayed via the front panel to see if the diaphragm needs replacement.
Do I need a strip chart recorder or external data logger?	No, the 6200T is equipped with a very powerful internal data acquisition system.

## 10.9. Technical Assistance

If this manual and its troubleshooting / repair sections do not solve your problems, technical assistance may be obtained from:

Teledyne Analytical Instruments, Customer Service,  
 16830 Chestnut Street  
 City of Industry, California 91748, USA  
 TEL: 626-934-1500 or 888-789-8168  
 FAX: 626-934-1651  
 EMAIL: [TETCI\\_customerservice@teledyne.com](mailto:TETCI_customerservice@teledyne.com)  
[www.teledyne-ai.com](http://www.teledyne-ai.com)

## 11. PRINCIPLES OF OPERATION

This section describes the principles of operation for the 6200T, TS analyzer. It also describes the principles of operation for pneumatics (Section 11.2), electronics (Section 11.3), communication interfaces (11.4) and software (11.5).

### 11.1. Sulfur Dioxide (SO<sub>2</sub>) Sensor Principles of operation

The 6200T UV Fluorescence SO<sub>2</sub> Analyzer is a microprocessor controlled analyzer that determines the concentration of sulfur dioxide (SO<sub>2</sub>), in a sample gas drawn through the instrument. It requires that sample and calibration gases be supplied at ambient atmospheric pressure in order to establish a constant gas flow through the sample chamber where the sample gas is exposed to ultraviolet light; this exposure causes the SO<sub>2</sub> molecules to change to an excited state (SO<sub>2</sub>\*). As these SO<sub>2</sub>\* molecules decay into SO<sub>2</sub> they fluoresce. The instrument measures the amount of fluorescence to determine the amount of SO<sub>2</sub> present in the sample gas.

Calibration of the instrument is performed in software and usually does not require physical adjustments to the instrument. During calibration, the microprocessor measures the sensor output signal when gases with known amounts of SO<sub>2</sub> at various concentrations are supplied and stores these measurements in memory. The microprocessor uses these calibration values along with other performance parameters such as the PMT dark offset, UV lamp ratio and the amount of stray light present and measurements of the temperature and pressure of the sample gas to compute the final SO<sub>2</sub> concentration.

This concentration value and the original information from which it was calculated are stored in the unit's internal data acquisition system and reported to the user through a vacuum fluorescent display or as electronic data via several communication ports.

This concentration value and the original information from which it was calculated are stored in the unit's internal data acquisition system (refer to Section 0) and reported to the user through a vacuum fluorescent display or several communication ports.

#### 11.1.1. SO<sub>2</sub> Ultraviolet Fluorescence Measurement Principle

The physical principle upon which the 6200T's measurement method is based is the fluorescence that occurs when sulfur dioxide (SO<sub>2</sub>) is excited by ultraviolet light with wavelengths in the range of 190 nm-230 nm. This reaction is a two-step process.

The first stage (Equation 11-1) occurs when SO<sub>2</sub> molecules are struck by photons of the appropriate ultraviolet wavelength. In the case of the 6200T, a band pass filter between the source of the UV light and the affected gas limits the wavelength of the light to approximately 214 nm. The SO<sub>2</sub> molecules absorb some of energy from the UV light causing one of the electrons of each of the affected molecules to move to a higher energy orbital state.

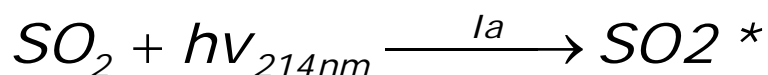

(Equation 11-1)

The amount SO<sub>2</sub> converted to excited SO<sub>2</sub>\* in the sample chamber is dependent on the average intensity of the UV light (*Ia*) and not its peak intensity because the intensity of UV light is not constant in every part of the sample chamber. Some of the photons are absorbed by the SO<sub>2</sub> as the light travels through the sample gas.



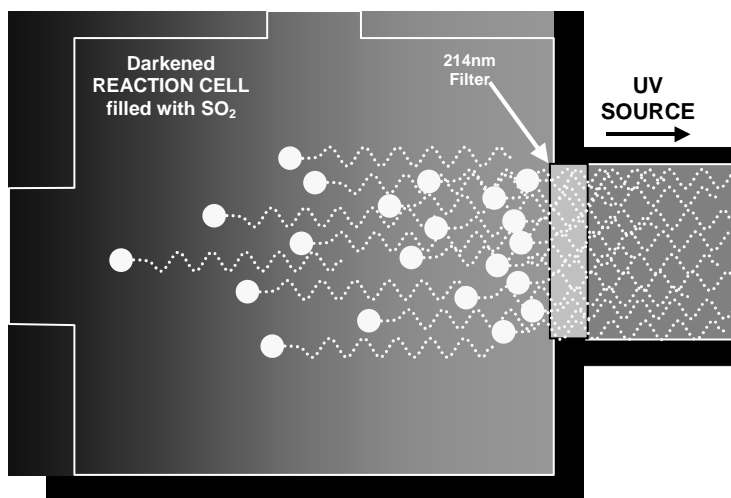

**Figure 11-1: UV Absorption**

The equation for defining the average intensity of the UV light ( $I_a$ ) is:

$$I_a = I_0 [1 - \exp(-ax(SO_2))]$$

(Equation 11-2)

Where:

$I_0$  = Intensity of the excitation UV light.

$a$  = The absorption coefficient of SO<sub>2</sub> (a constant).

$SO_2$  = Concentration of SO<sub>2</sub> in the sample chamber.

$x$  = The distance between the UV source and the SO<sub>2</sub> molecule(s) being affected (path length).

second stage of this reaction occurs after the SO<sub>2</sub> reaches its excited state (SO<sub>2</sub>\*). Because the system will seek the lowest available stable energy state, the SO<sub>2</sub>\* molecule quickly returns to its ground state (Equation 10-3) by giving off the excess energy in the form of a photon ( $h\nu$ ). The wavelength of this fluoresced light is also in the ultraviolet band but at a longer (lower energy) wavelength centered at 330nm.

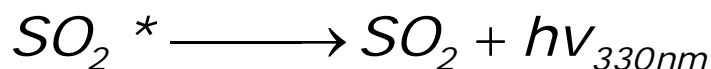

(Equation 11-3)

The amount of detectable UV given off by the decay of the SO<sub>2</sub>\* is affected the rate at which this reaction occurs ( $k$ ).

$$F = k(SO_2^*)$$

(Equation 11-4)

Where:

**F** = the amount of fluorescent light given off.**k** = The rate at which the  $SO_2^*$  decays into  $SO_2$ . **$SO_2^*$**  = Amount of excited  $SO_2$  in the sample chamber.

Therefore:

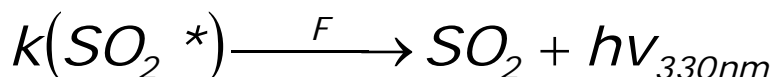

(Equation 11-5)

Finally, the function (**k**) is affected by the temperature of the gas. The warmer the gas, the faster the individual molecules decay back into their ground state and the more photons of UV light are given off per unit of time.

In summary, given that the absorption rate of  $SO_2$  (**a**) is constant, the amount of fluorescence (**F**) is a result of:

- The amount of excited  $SO_2^*$  created which is affected by the variable factors from (Equation 11-2) above: concentration of  $SO_2$ ; intensity of UV light ( **$I_0$** ); path length of the UV light (**x**) and;
- The amount of fluorescent light created which is affected by the variable factors from (Equation 11-5): the amount of  $SO_2^*$  present and the rate of decay (**k**) which changes based on the temperature of the gas.

When and the intensity of the light ( **$I_0$** ) is known; path length of excited light is short (**x**); the temperature of the gas is known and compensated for so that the rate of  $SO_2^*$  decay is constant (**k**). and; no interfering conditions are present (such as interfering gases or stray light); the amount of fluorescent light emitted (**F**) is directly related to the concentration of the  $SO_2$  in the Sample Chamber.

The Model 6200T, UV Fluorescence TS Analyzer is specifically designed to create these circumstances.

- The light path is very short (**x**).
- A reference detector measures the intensity of the available excitation UV light and is used to remove effects of lamp drift ( **$I_0$** ).
- The temperature of the sample gas is measured and controlled via heaters attached to the sample chamber so that the rate of decay (**k**) is constant.
- A special hydrocarbon scrubber removes the most common interfering gases from the sample gas.
- And finally, the design of the sample chamber reduces the effects of stray light via its optical geometry and spectral filtering.

The net result is that any variation in UV fluorescence can be directly attributed to changes in the concentration of  $SO_2$  in the sample gas.



### 11.1.2. The UV Light Path

The optical design of the 6200T's sample chamber optimizes the fluorescent reaction between  $\text{SO}_2$  and UV Light (refer to Figure 11-2) and assure that only UV light resulting from the decay of  $\text{SO}_2^*$  into  $\text{SO}_2$  is sensed by the instruments fluorescence detector.

UV radiation is generated by a lamp specifically designed to produce a maximum amount of light of the wavelength needed to excite  $\text{SO}_2$  into  $\text{SO}_2^*$  (214 nm) and a special reference detector circuit constantly measures lamp intensity (refer to (Equation 11-2)). A Photo Multiplier Tube (PMT) detects the UV given off by the  $\text{SO}_2^*$  decay (330 nm) and outputs an analog signal. Several focusing lenses and optical filters ensure that both detectors are exposed to an optimum amount of only the right wavelengths of UV. To further assure that the PMT only detects light given off by decaying  $\text{SO}_2^*$  the pathway of the excitation UV and field of view of the PMT are perpendicular to each other and the inside surfaces of the sample chamber are coated with a layer of black Teflon<sup>®</sup> that absorbs stray light.

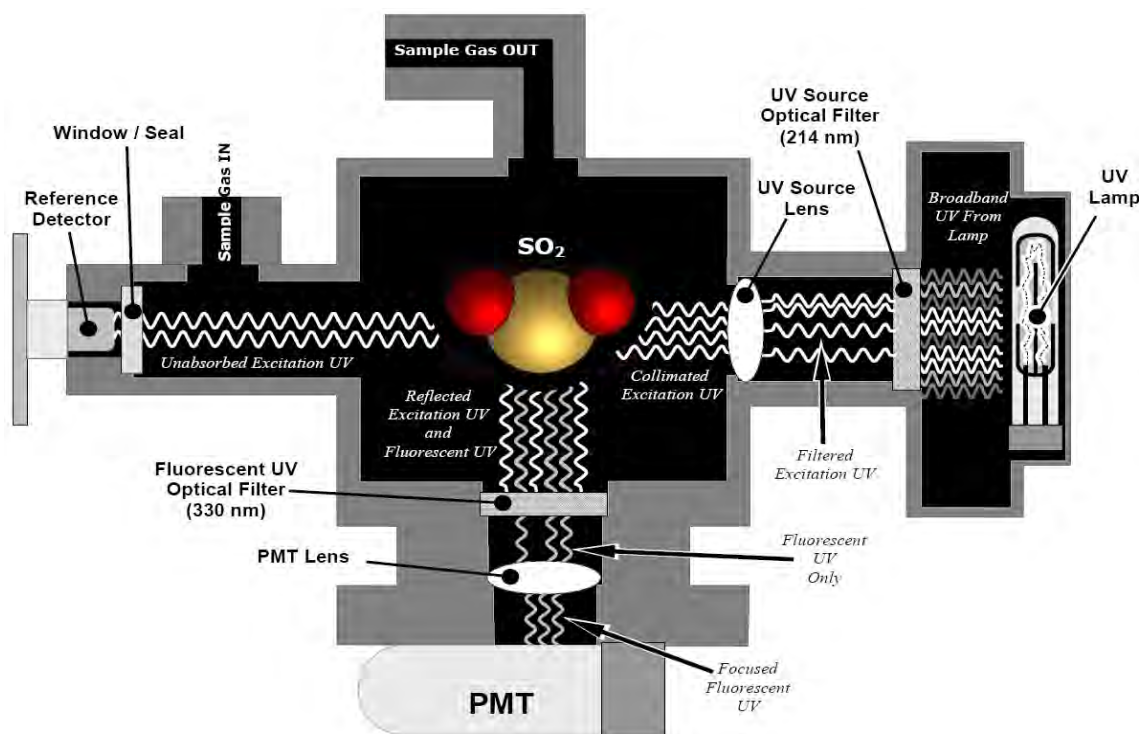

Figure 11-2: UV Light Path

### 11.1.3. UV Source Lamp

The source of excitation UV light for the 6200T is a low pressure zinc-vapor lamp. An AC voltage heats up and vaporizes zinc contained in the lamp element creating a light-producing plasma arc. Zinc-vapor lamps are preferred over the more common mercury-vapor lamps for this application because they produce very strong emission levels at the wavelength required to convert  $\text{SO}_2$  to  $\text{SO}_2^*$ , 213.9 nm (refer to Figure 11-4).

The lamp used in the 6200T is constructed with a vacuum jacket surrounding a double-bore lamp element (refer to Figure 11-3). The vacuum jacket isolates the plasma arc from most external temperature fluctuations. The jacket also contains thermal energy created by the lamp's

operation therefore helping the lamp to heat up and maintain proper vaporization temperature. Light is emitted through a 20 mm x 5 mm portal.

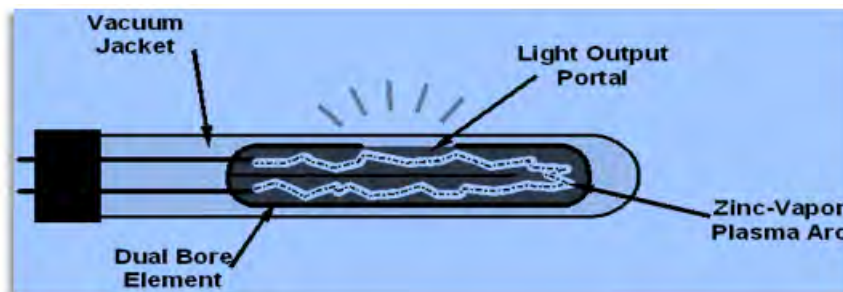

Figure 11-3: Source UV Lamp Construction

#### 11.1.4. The Reference Detector

A vacuum diode, UV detector that converts UV light to a DC current is used to measure the intensity of the excitation UV source lamp. It is located directly across from the source lamp at the back of a narrow tube-shaped light trap, which places it directly in the path of the excitation UV light. A window transparent to UV light provides an air-proof seal that prevents ambient gas from contaminating the sample chamber. The shape of the light trap and the fact that the detector is blind to wavelengths other than UV no extra optical filtering is needed.

#### 11.1.5. The PMT

The amount of fluoresced UV produced in the sample chamber is much less than the intensity of excitation UV source lamp (refer to Figure 11-4). Therefore a much more sensitive device is needed to detect this light with enough resolution to be meaningful. The 6200T uses a Photo Multiplier Tube or PMT for this purpose.

A PMT is typically a vacuum tube containing a variety of specially designed electrodes. Photons enter the PMT and strike a negatively charged photo cathode causing it to emit electrons. These electrons are accelerated by a high voltage applied across a series of special electrodes called dynodes that multiply the amount of electrons until a useable current signal is generated. This current increases or decreases with the amount of detected light (refer to Section 11.3.3 for more details regarding the electronic operation of the PMT).

#### 11.1.6. UV Lamp Shutter & PMT Offset

Inherent in the operation of both the reference detector and the PMT are a minor electronic offsets. The degree of offset differs from detector to detector and from PMT to PMT and can change over time as these components age.

To account for these offsets the 6200T includes a shutter, located between the UV Lamp and the source filter that periodically cuts off the UV light from the sample chamber. This happens every 30 minutes. The analyzer records the outputs of both the reference detector and the PMT during this dark period and factors them into the SO<sub>2</sub> concentration calculation.

- The reference detector offset is stored as and viewable via the front panel as the test function **DRK LMP**.
- The PMT offset is stored as and viewable via the front panel as the test function **DRK PMT**.





### 11.1.7. Optical Filters

The 6200T analyzer uses two stages of optical filters to enhance performance. The first stage conditions the UV light used to excite the  $\text{SO}_2$  by removing frequencies of light that are not needed to produce  $\text{SO}_2^*$ . The second stage protects the PMT detector from reacting to light not produced by the  $\text{SO}_2^*$  returning to its ground state.

#### 11.1.7.1. UV Source Optical Filter

Zinc-vapor lamps output light at other wavelengths beside the 214nm required for the  $\text{SO}_2 \rightarrow \text{SO}_2^*$  transformation including a relatively bright light of the same wavelength at which  $\text{SO}_2^*$  fluoresces as it returns to its  $\text{SO}_2$  ground state (330 nm). In fact, the intensity of light emitted by the UV lamp at 330nm is so bright, nearly five orders of magnitude brighter than that resulting from the  $\text{SO}_2^*$  decay, it would drown out the  $\text{SO}_2^*$  fluorescence.

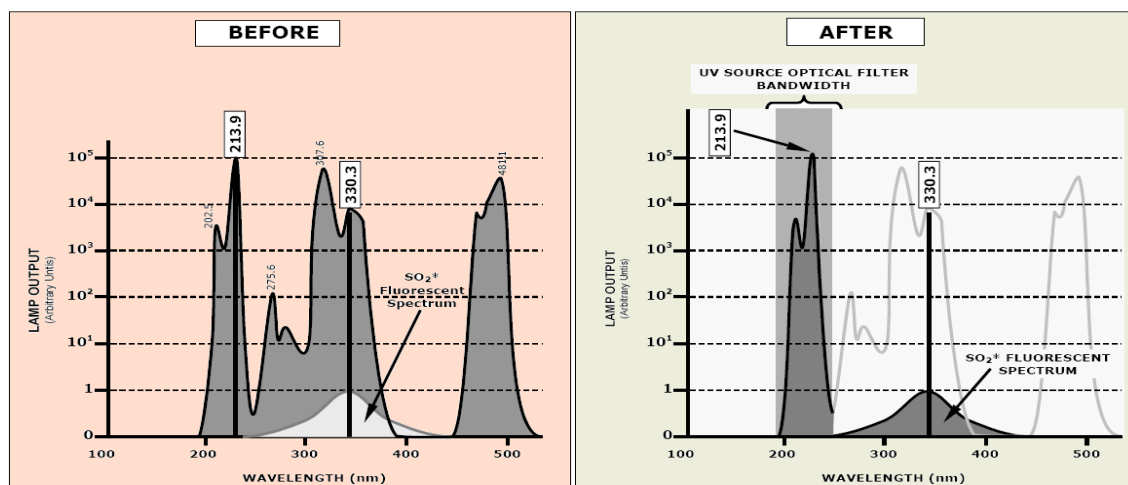

**Figure 11-4: Excitation Lamp UV Spectrum Before/After Filtration**

To solve this problem, the light emitted by the excitation UV lamp passes through a band pass filter that screens out photons with wavelengths outside the spectrum required to excite  $\text{SO}_2$  into  $\text{SO}_2^*$  (refer to Figure 11-4).

## 11.1.7.2. PMT Optical Filter

The PMT used in the 6200T reacts to a wide spectrum of light which includes much of the visible spectrum and most of the UV spectrum. Even though the 214 nm light used to excite the  $\text{SO}_2$  is focused away from the PMT, some of it scatters in the direction of the PMT as it interacts with the sample gas. A second optical band pass filter placed between the sample chamber (refer to Figure 11-2) and the PMT strips away light outside of the fluorescence spectrum of decaying  $\text{SO}_2^*$  (refer to

Figure 11-5) including reflected UV from the source lamp and other stray light.

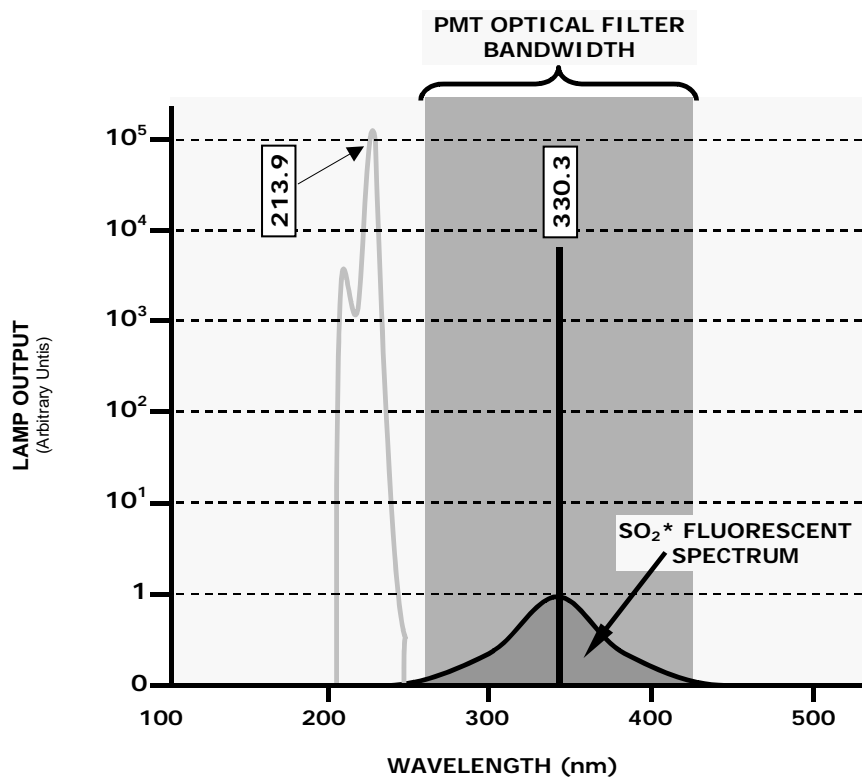
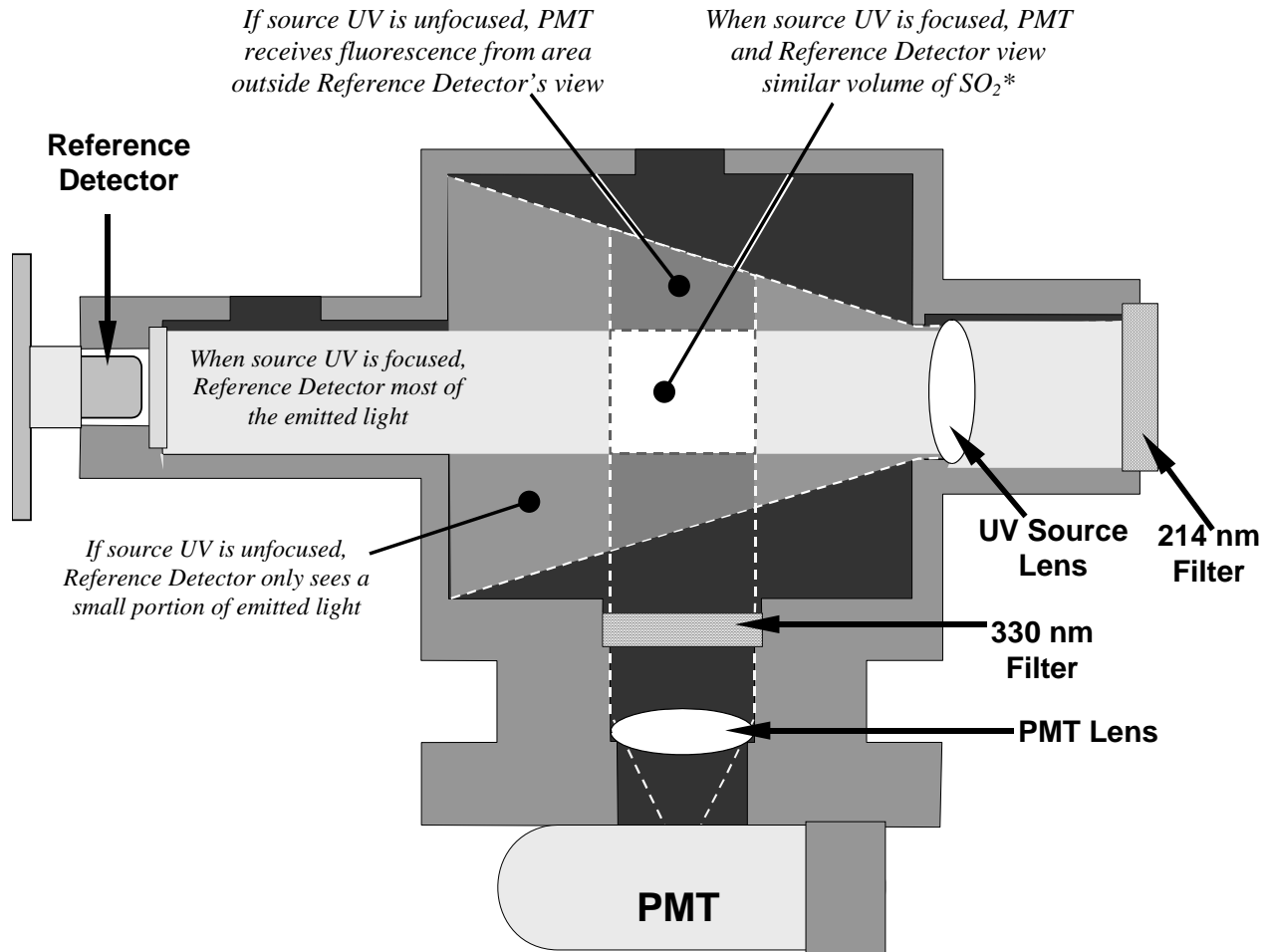

Figure 11-5: PMT Optical Filter Bandwidth



### 11.1.8. Optical Lenses

Two optical lenses are used to focus and optimize the path of light through the sample chamber.



**Figure 11-6: Effects of Focusing Source UV in Sample Chamber**

A lens located between PMT and the sample chamber collects as much of the fluoresced UV created there as possible and focuses it on the most sensitive part of the PMT's photo cathode.

Another lens located between the excitation UV source lamp and the sample chamber collimates the light emitted by the lamp into a steady, circular beam and focuses that beam directly onto the reference detector. This allows the reference detector to accurately measure the effective intensity of the excitation UV by eliminating the effect of flickering inherent in the plasma arc that generates the light.

Ensure that all of the light emitted by the source lamp, passes through the 214 nm filter and not absorbed by the SO<sub>2</sub> reaches the reference detector. Conversely, this also makes sure that the volume of sample gas affected by the excitation beam is similar to the volume of fluorescing SO<sub>2</sub>\* being measured by the PMT, eliminating a possible source of measurement offset.

### 11.1.9. Measurement Interferences

It should be noted that the fluorescence method for detecting SO<sub>2</sub> is subject to interference from a number of sources. The 6200T has been successfully tested for its ability to reject interference from most of these sources.

#### 11.1.9.1. Direct Interference

The most common source of interference is from other gases that fluoresce in a similar fashion to SO<sub>2</sub> when exposed to UV Light. The most significant of these is a class of hydrocarbons called polynuclear aromatics (PNA) of which xylene and naphthalene are two prominent examples. Nitrogen oxide fluoresces in a spectral range near to SO<sub>2</sub>. For critical applications where high levels of NO are expected an optional optical filter is available that improves the rejection of NO (contact customer service for more information).

- The 6200T Analyzer has several methods for rejecting interference from these gases:
- A special scrubber (kicker) mechanism removes any PNA chemicals present in the sample gas before it reaches the sample chamber.
- The exact wavelength of light needed to excite a specific non-SO<sub>2</sub> fluorescing gas is removed by the source UV optical filter.
- The light given off by Nitrogen Oxide and many of the other fluorescing gases is outside of the bandwidth passed by the PMT optical filter.

#### 11.1.9.2. UV Absorption by Ozone

Because ozone absorbs UV Light over a relatively broad spectrum it could cause a measurement offset by absorbing some of the UV given off by the decaying SO<sub>2</sub>\* in the sample chamber. The 6200T prevents this from occurring by having a very short light path between the area where the SO<sub>2</sub>\* fluorescence occurs and the PMT detector. Because the light path is so short, the amount of O<sub>3</sub> needed to cause a noticeable effect would be much higher than could be reasonably expected in any application for which this instrument is intended.

#### 11.1.9.3. Dilution

Certain gases with higher viscosities can lower the flow rate through the critical flow orifice that controls the movement of sample gas through the analyzer reducing the amount of sample gas in the sample chamber and thus the amount of SO<sub>2</sub> available to react with the UV light. While this can be a significant problem for some analyzers, the design of the 6200T is very tolerant of variations in sample gas flow rate and therefore does not suffer from this type of interference.

#### 11.1.9.4. Third Body Quenching

While the decay of SO<sub>2</sub>\* to SO<sub>2</sub> happens quickly, it is not instantaneous. Because it is not instantaneous it is possible for the extra energy possessed by the excited electron of the SO<sub>2</sub>\* molecule to be given off as kinetic energy during a collision with another molecule. This in effect heats the other molecule slightly and allows the excited electron to move into a lower energy orbit without emitting a photon.

The most significant interferents in this regard are nitrogen oxide (NO), carbon dioxide (CO<sub>2</sub>), water vapor (H<sub>2</sub>O) and molecular oxygen (O<sub>2</sub>). In ambient applications the quenching effect of these gases is negligible. For stack applications where the concentrations of some or all of these may be very high, specific steps MUST be taken to remove them from the sample gas before it enters the analyzer.



### 11.1.9.5. Light Pollution

Because the 6200T measures light as a means of calculating the amount of SO<sub>2</sub> present, obviously stray light can be a significant interfering factor. The 6200T removes this interference source in several ways.

- The sample chamber is designed to be completely light tight to light from sources other than the excitation UV source lamp.
- All pneumatic tubing leading into the sample chamber is completely opaque in order to prevent light from being piped into the chamber by the tubing walls.
- The optical filters discussed in Section 11.1.7; remove UV with wavelengths extraneous to the excitation and decay of SO<sub>2</sub>/SO<sub>2</sub>\*.
- Most importantly, during instrument calibration the difference between the value of the most recently recorded PMT offset (refer to Section 11.1.6) and the PMT output while measuring zero gas (calibration gas devoid of SO<sub>2</sub>) is recorded as the test function **OFFSET**. This **OFFSET** value is used during the calculation of the SO<sub>2</sub> concentration.

Since this offset is assumed to be due to stray light present in the sample chamber is also multiplied by the **SLOPE** and recorded as the function **STR. LGT**. Both **OFFSET** & **STR. LGT** are viewable via the front panel (refer to Section 4.1.1).

## 11.2. Pneumatic Operation

IMPORTANT

### IMPACT ON READINGS OR DATA

It is important that the sample airflow system is leak-tight and not pressurized over ambient pressure. Regular leak checks should be performed on the analyzer as described in the maintenance schedule, Table 9-1. Procedures for correctly performing leak checks can be found in Section 9.3.6.

IMPORTANT

### Relative Pressure versus Absolute Pressure

In this manual vacuum readings are given in inches of mercury absolute pressure (in-Hg-A), i.e. indicate an absolute pressure referenced against zero (a perfect vacuum).



11.2.1. Sample Gas Flow

The flow of gas through the 6200T UV Fluorescence SO<sub>2</sub> Analyzer is created by a small internal pump that pulls air through the instrument.

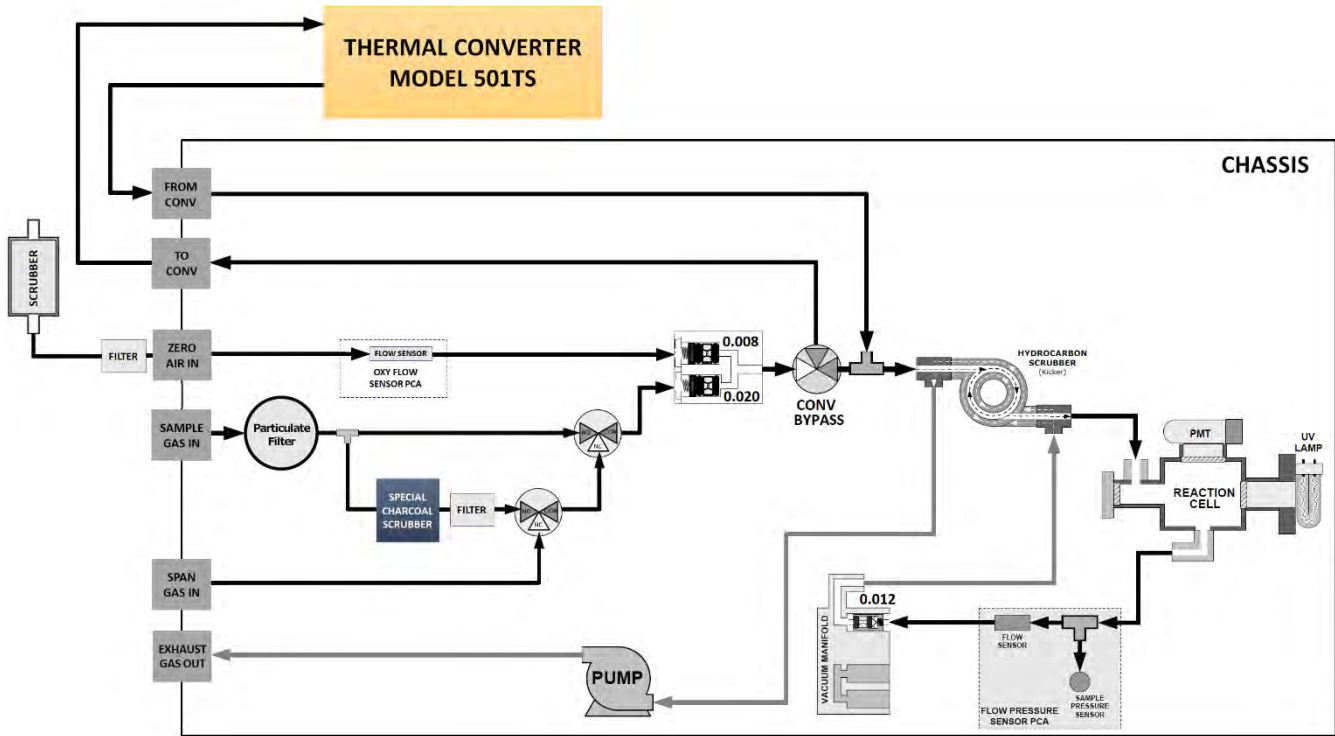

Figure 11-7: 6200T, Gas Flow



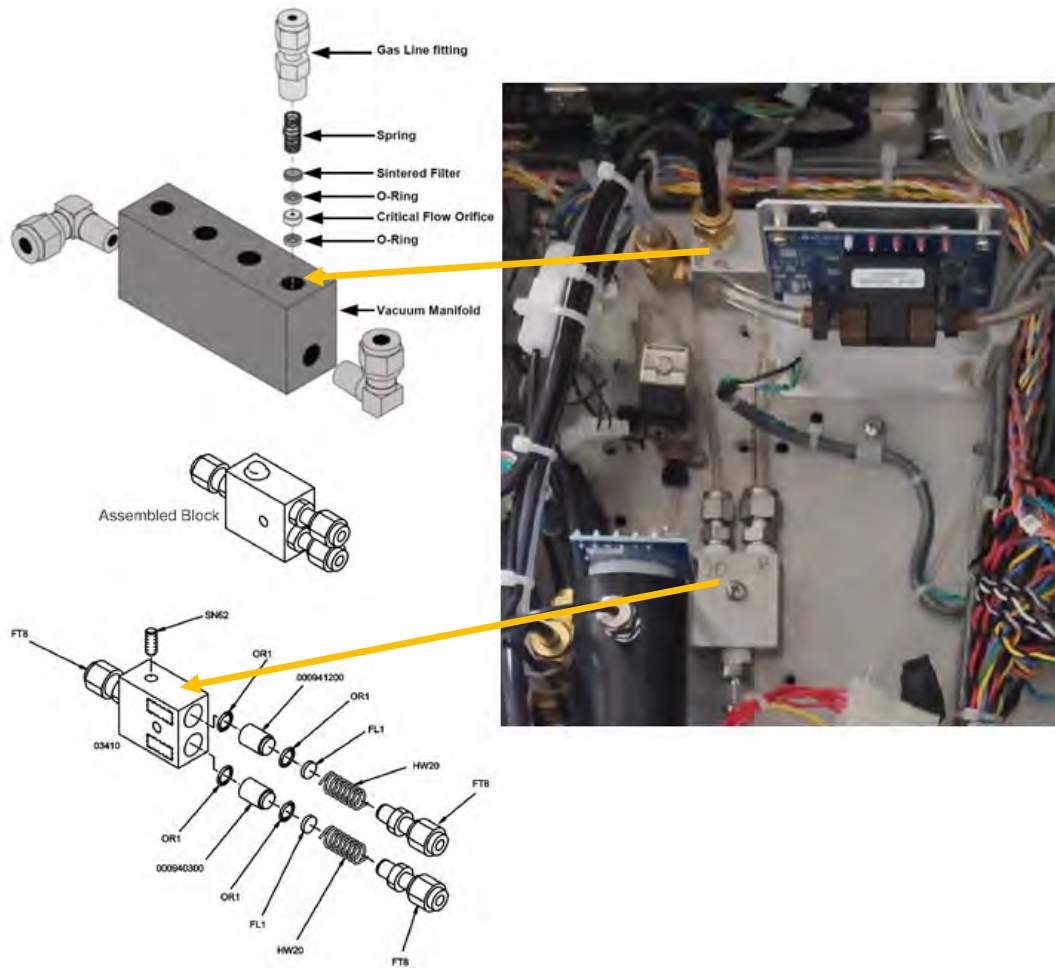

Figure 11-8: Location of Critical Flow Orifice

### 11.2.2. Flow Rate Control



fer to

Figure 11-8) to maintain a constant flow rate of the sample gas through the instrument. This assembly consists of:

- A critical flow orifice.
- Two o-rings: Located just before and after the critical flow orifice, the o-rings seal the gap between the walls of assembly housing and the critical flow orifice.
- A spring: Applies mechanical force needed to form the seal between the o-rings, the critical flow orifice and the assembly housing.

#### 11.2.2.1. Critical Flow Orifice

The most important component of this flow control assembly is the critical flow orifice. Critical flow orifices are a simple way to regulate stable gas flow rates. They operate without moving parts by taking advantage of the laws of fluid dynamics. Restricting the flow of gas through

the orifice creates a pressure differential. This pressure differential combined with the action of the analyzer's pump draws the gas through the orifice.

As the pressure on the downstream side of the orifice (the pump side) continues to drop, the speed that the gas flows through the orifice continues to rise. Once the ratio of upstream pressure to downstream pressure is greater than 2:1, the velocity of the gas through the orifice reaches the speed of sound. As long as that ratio stays at least 2:1 the gas flow rate is unaffected by any fluctuations, surges, or changes in downstream pressure because such variations only travel at the speed of sound themselves and are therefore cancelled out by the sonic shockwave at the downstream exit of the critical flow orifice.

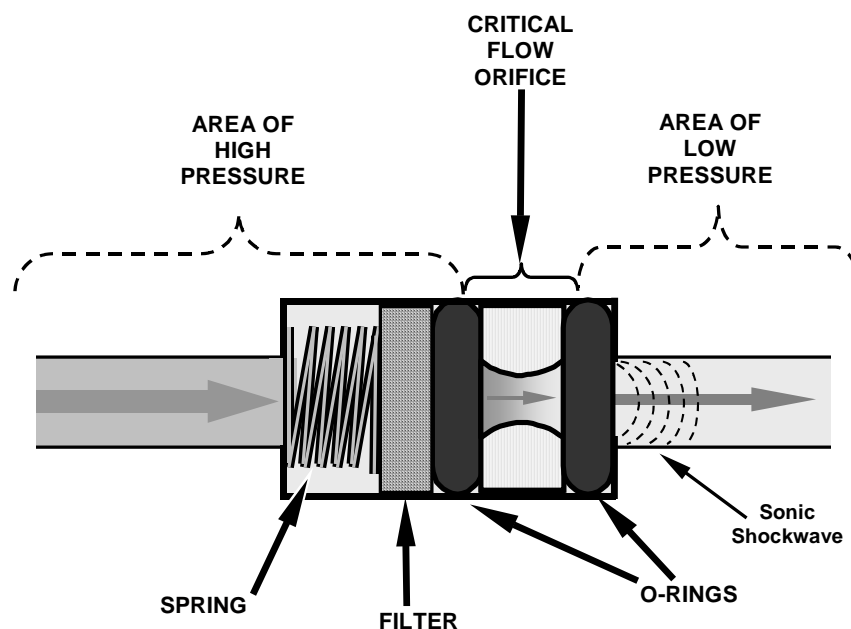

**Figure 11-9: Flow Control Assembly & Critical Flow Orifice**

The actual flow rate of gas through the orifice (volume of gas per unit of time), depends on the size and shape of the aperture in the orifice. The larger the hole, the more gas molecules, moving at the speed of sound, pass through the orifice. Because the flow rate of gas through the orifice is only related to the minimum 2:1 pressure differential and not absolute pressure the flow rate of the gas is also unaffected by degradations in pump efficiency due to age.

The critical flow orifice used in the 6200T is designed to provide a flow rate of 650 cm<sup>3</sup>/min.

#### 11.2.2.2. Sample Particulate Filter

To remove particles in the sample gas, the analyzer is equipped with a Teflon membrane filter of 47 mm diameter (also referred to as the sample filter) with a 1 μm pore size. The filter is accessible through the front panel, which folds down, and should be changed according to the suggested maintenance schedule listed in Table 9-1.

#### 11.2.3. Hydrocarbon Scrubber (Kicker)

It is very important to ensure that the air supplied sample chamber is clear of hydrocarbons. To accomplish this task the 6200T uses a single tube permeation scrubber. The scrubber consists of a single tube of a specialized plastic that absorbs hydrocarbons very well. This tube is located within outer flexible plastic tube shell. As gas flows through the inner tube, hydrocarbons are





absorbed into the membrane walls and transported through the membrane wall and into the hydrocarbon free, purge gas flowing through the outer tube. This process is driven by the hydrocarbon concentration gradient between the inner and outer of the tubes.

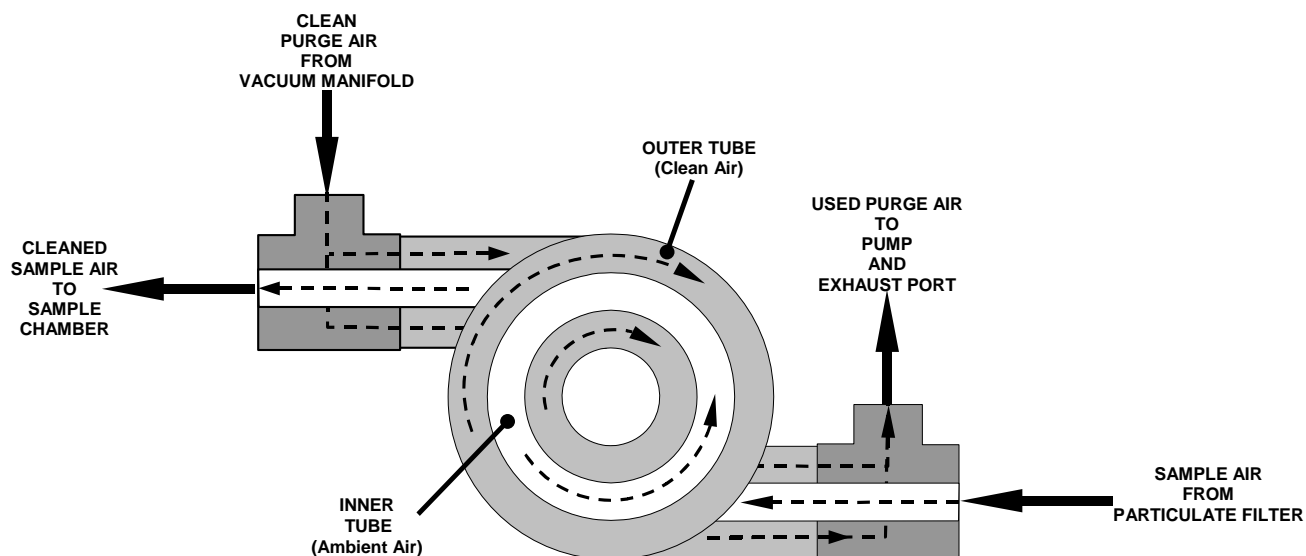

**Figure 11-10: 6200T Hydrocarbon Scrubber (Kicker)**

In the 6200T some of the cleaned air from the inner tube is returned to be used as the purge gas in the outer tube (refer to

Figure 11-10). This means that when the analyzer is first started, the concentration gradient between the inner and outer tubes is not very large and the scrubber's efficiency is relatively low. When the instrument is turned on after having been off for more than 30 minutes, it takes a certain amount of time for the gradient to become large enough for the scrubber to adequately remove hydrocarbons from the sample air.

#### 11.2.4. Pneumatic Sensors

The 6200T uses two pneumatic sensors to verify gas streams. These sensors are located on a printed circuit assembly, called the pneumatic pressure/flow sensor board. The flow simultaneously enters the sample pressure sensor and the flow sensor from the outlet of the reaction cell.

##### 11.2.4.1. Sample Pressure Sensor

An absolute pressure transducer plumbed to the input of the analyzer's sample chamber is used to measure the pressure of the sample gas before it enters the chamber. This upstream used to validate the critical flow condition (2:1 pressure ratio) through the instrument's critical flow orifice (refer to Section 11.2.2). Also, if the Temperature/Pressure Compensation (TPC) feature is turned on (refer to Section 11.5.3), the output of this sensor is also used to supply pressure data for that calculation.

The actual pressure measurement is viewable through the analyzer's front panel display as the test function **PRESS**.

##### 11.2.4.2. Sample Flow Sensor

A thermal-mass flow sensor is used to measure the sample flow through the analyzer. This sensor is also mounted on the pneumatic pressure/flow sensor board upstream of the sample chamber. The flow rate is monitored by the CRT which issues a warning message (**SAMP FLOW WARN**) if the flow rate is too high or too low.

The flow rate of the sample gas is viewable via the front panel as the **SAMP FL** test function.

### 11.3. Electronic Operation

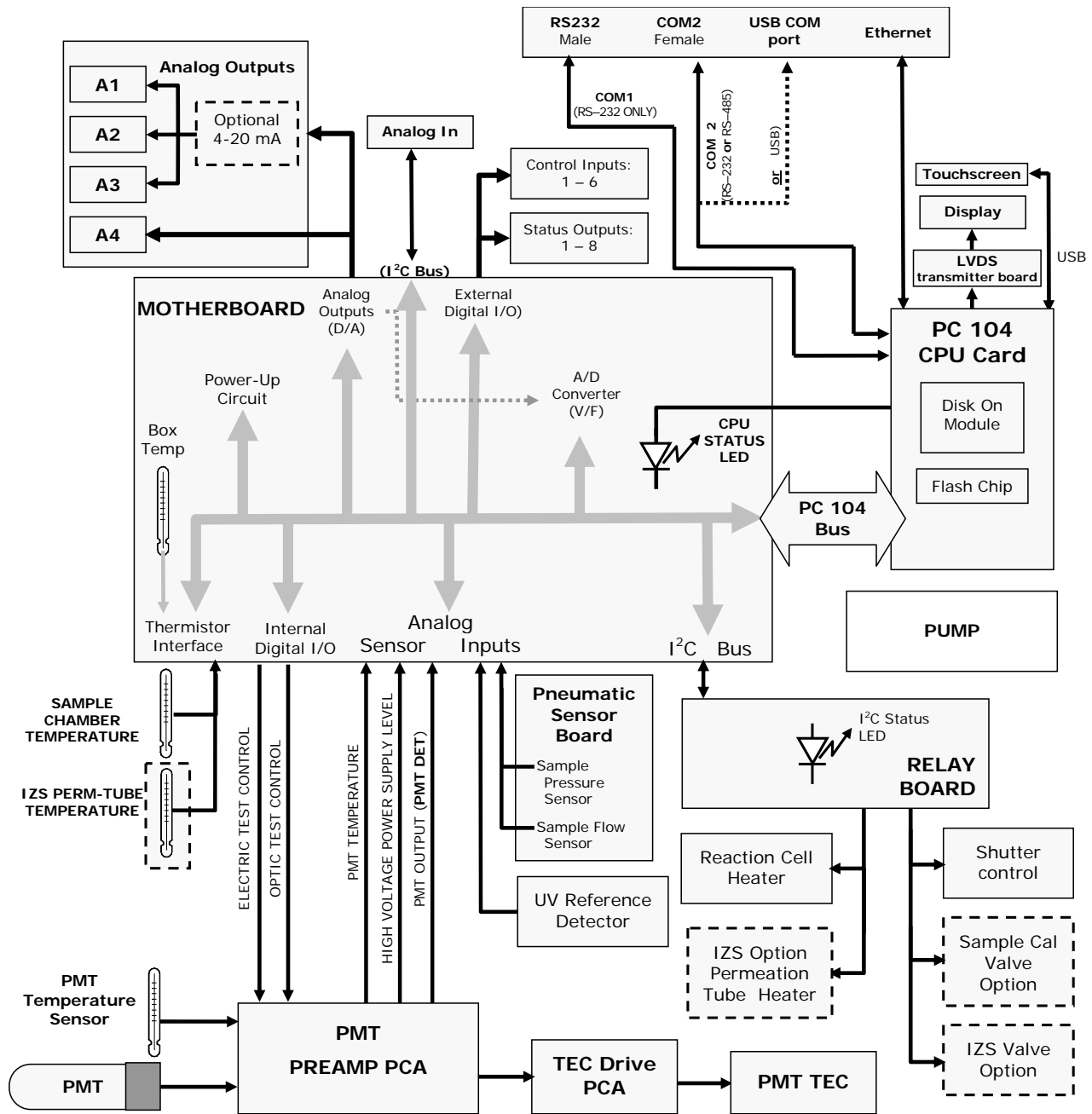

Figure 11-8: 6200T Electronic Block Diagram

The core of the analyzer is a microcomputer that controls various internal processes, interprets data, makes calculations, and reports results using specialized firmware developed by Teledyne Analytical Instruments. It communicates with the user as well as receives data from and issues commands to a variety of peripheral devices through a separate printed circuit assembly to which the CPU is mounted: the motherboard.



The motherboard is directly mounted to the rear panel and collects data, performs signal conditioning duties and routes incoming and outgoing signals between the CPU and the analyzer's other major components.

Concentration data of the 6200T are generated by the Photo Multiplier Tube (PMT), which produces an analog current signal corresponding to the brightness of the fluorescence reaction in the sample chamber. This current signal is amplified to a DC voltage signal (front panel test parameter **PMT**) by a PMT preamplifier printed circuit assembly (located on top of the sensor housing). **PMT** is converted to digital data by a bi-polar, analog-to-digital converter, located on the motherboard.

In addition to the PMT signal, a variety of sensors report the physical and operational status of the analyzer's major components, again through the signal processing capabilities of the motherboard. These status reports are used as data for the SO<sub>2</sub> concentration calculation (e.g. pressure and temperature reading used by the temperature/pressure compensation feature) and as trigger events for certain warning messages and control commands issued by the CPU. They are stored in the CPU's memory and, in most cases, can be viewed through the front panel display.

The CPU communicates with the user and the outside world in a variety of ways:

- Through the analyzer's front panel LCD touch-screen interface
- RS-232 and RS-485 serial I/O channels
- Various analog voltage and current outputs
- Several digital I/O channels
- Ethernet

Finally, the CPU issues commands (also over the I<sup>2</sup>C bus) to a series of relays and switches located on a separate printed circuit assembly, the relay board (located in the rear of the chassis on its own mounting bracket) to control the function of key electromechanical devices such as valves and heaters.

### 11.3.1. CPU

The unit's CPU card, installed on the motherboard located inside the rear panel, is a low power (5 VDC, 720mA max), high performance, Vortex 86SX-based microcomputer running Windows CE. Its operation and assembly conform to the PC 104 specification..

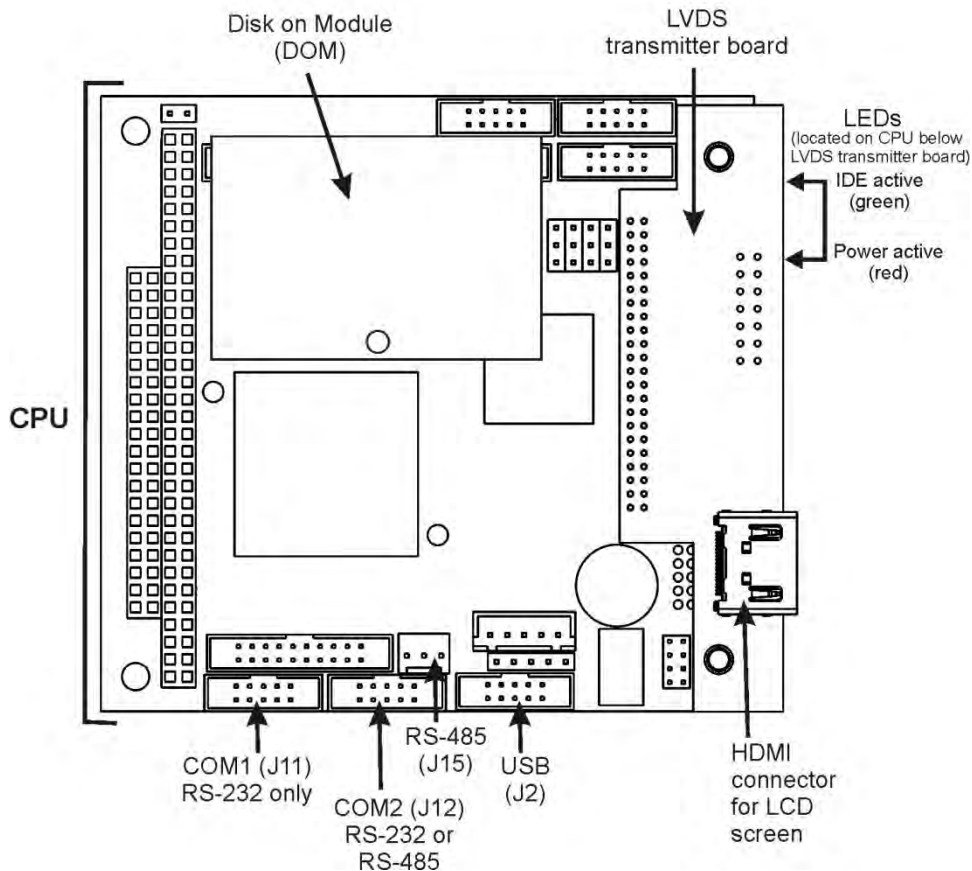

**Figure 11-9: CPU Board Annotated**

The CPU includes two types of non-volatile data storage: a Disk on Module (DOM) and an embedded flash chip.

#### 11.3.1.1. Disk On Module (DOM)

The DOM is a 44-pin IDE flash chip with storage capacity to 256 MB. It is used to store the computer's operating system, the Teledyne Analytical Instruments firmware, and most of the operational data generated by the analyzer's internal data acquisition system (DAS). Embedded in the DOM is a flash chip.

#### 11.3.1.2. Flash Chip

This non-volatile, embedded flash chip includes 2MB of storage for calibration data as well as a backup of the analyzer configuration. Storing these key data onto a less heavily accessed chip significantly decreases the chance data corruption.

In the unlikely event that the flash chip should fail, the analyzer will continue to operate with just the DOM. However, all configuration information will be lost, requiring that the unit be recalibrated.



### 11.3.2. Sensor Module

Electronically, the 6200T sensor module is a group of components that: create the UV light that initiates the fluorescence reaction between SO<sub>2</sub> and O<sub>3</sub>; sense the intensity of that fluorescence; generate various electronic signals needed by the analyzer to determine the SO<sub>2</sub> concentration of the sample gas (refer to Section 11.1.1), and sense and control key environmental conditions such as the temperature of the sample gas and the PMT.

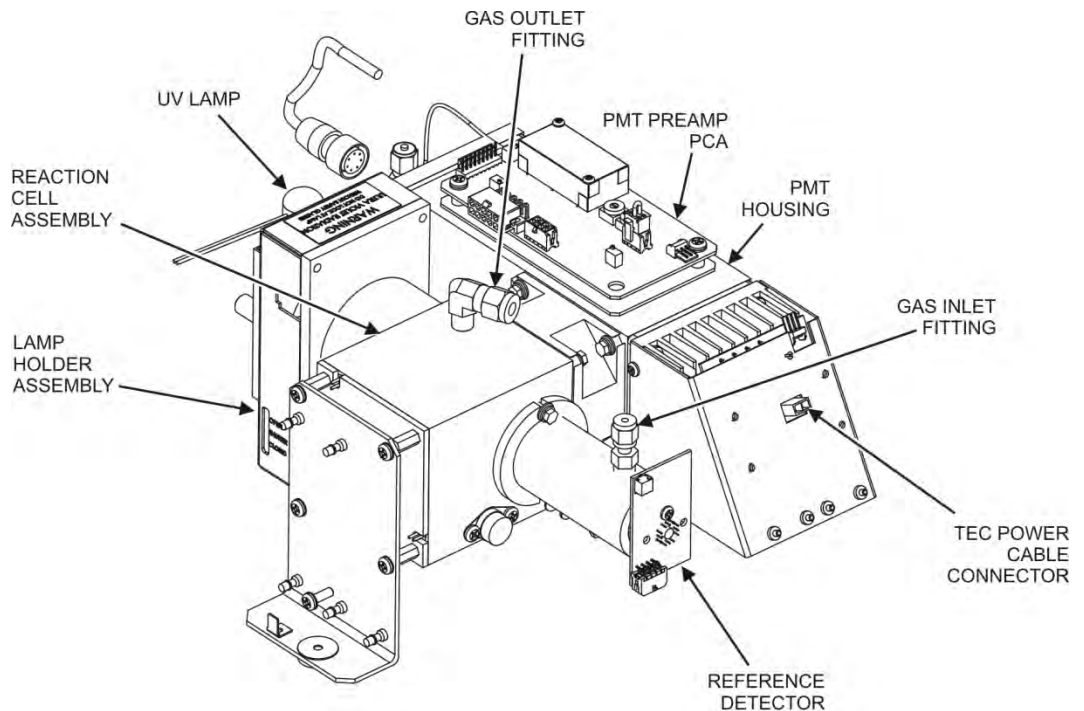

**Figure 11-10: 6200T Sensor Module**

These components are divided into two significant subassemblies: the sample chamber and the PMT assembly.

Figure 11-11 shows an exploded view of the sample chamber assembly

Figure 11-12 shows an exploded view of the PMT Assembly

### 11.3.2.1. Sample Chamber

The main electronic components of the sample chamber are the reference detector (refer to Section 11.1.4); the UV Lamp (refer to Section 11.1.3) and its electronically operated shutter (refer to Section 11.1.6); and the sample chamber heating circuit.

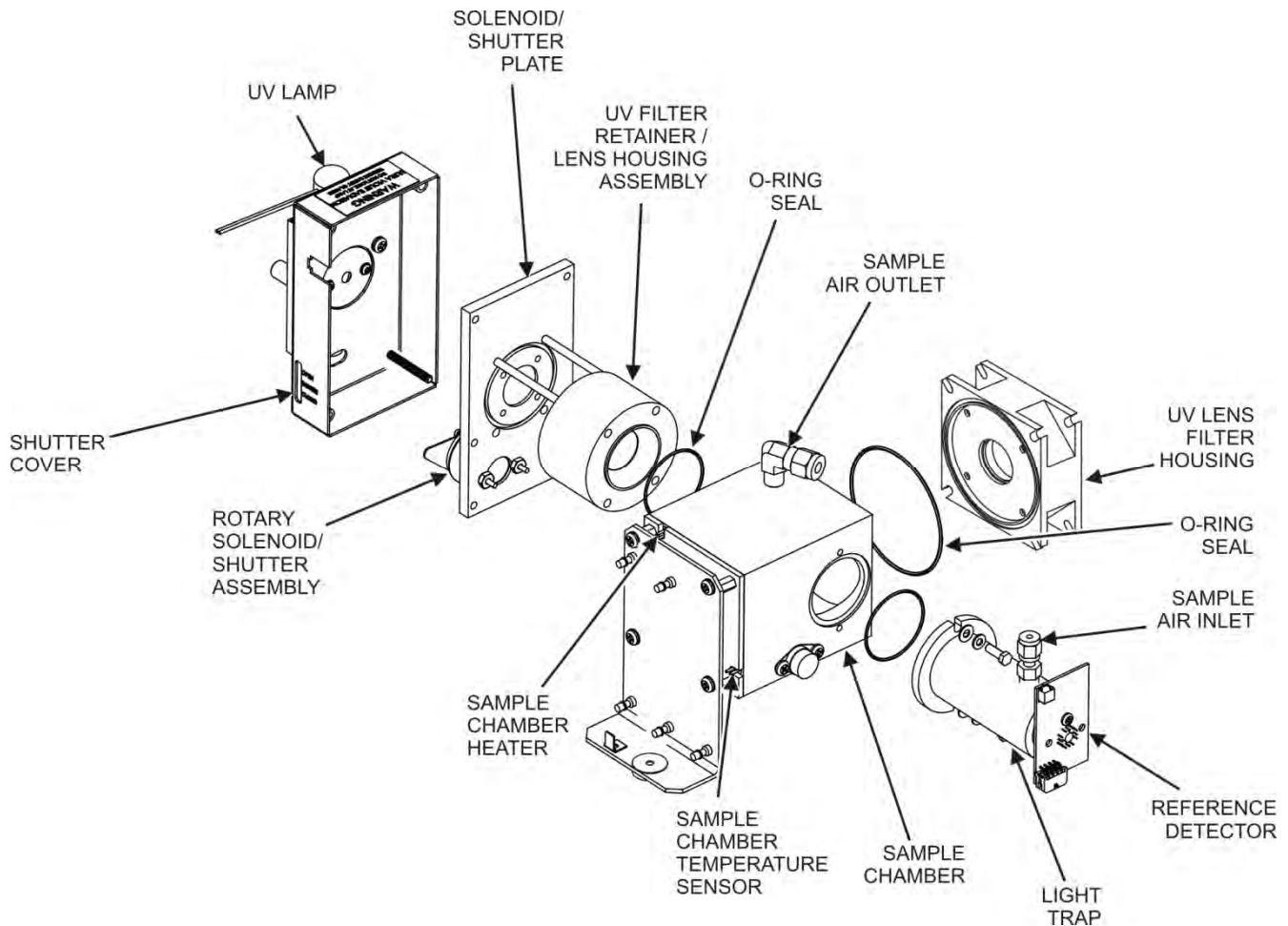

Figure 11-11: 6200T Sample Chamber

### 11.3.2.2. Sample Chamber Heating Circuit

In order to reduce temperature effects, the sample chamber is maintained at a constant 50°C, just above the high end of the instrument's operation temperature range. Two AC heaters, one embedded into the top of the sample chamber, the other embedded directly below the reference detector's light trap, provide the heat source. These heaters operate off of the instrument's main AC power and are controlled by the CPU through a power relay on the relay board. A thermistor, also embedded in the bottom of the sample chamber, reports the cell's temperature to the CPU through the thermistor interface circuitry of the motherboard.



### 11.3.3. Photo Multiplier Tube (PMT)

The 6200T uses a photo multiplier tube (PMT) to detect the amount of fluorescence created by the  $\text{SO}_2$  and  $\text{O}_3$  reaction in the sample chamber.

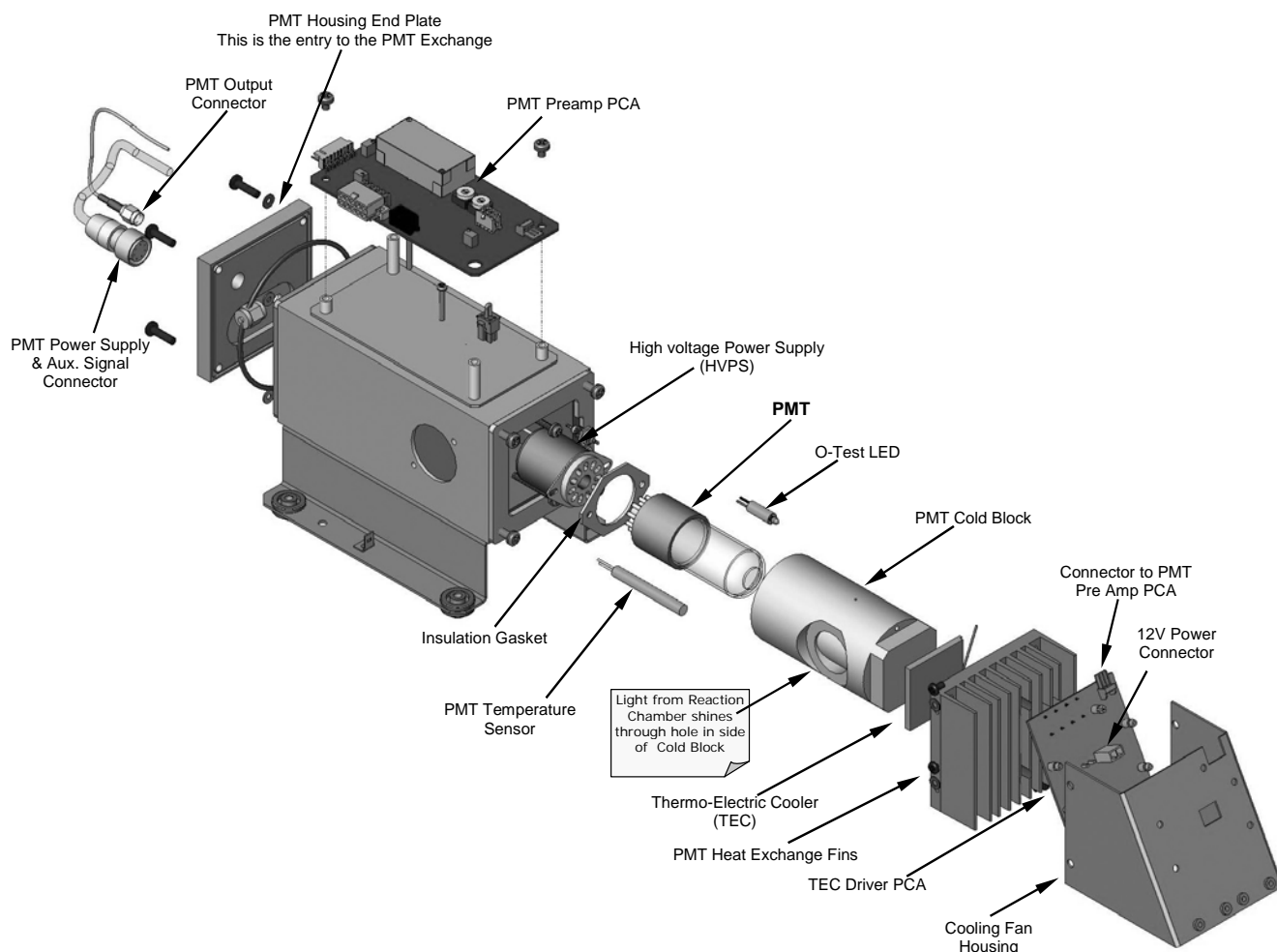

**Figure 11-12: PMT Housing Assembly**

A typical PMT is a vacuum tube containing a variety of specially designed electrodes. Photons from the reaction are filtered by an optical high-pass filter, enter the PMT and strike a negatively charged photo cathode causing it to emit electrons. A high voltage potential across these focusing electrodes directs the electrons toward an array of high voltage dynodes. The dynodes in this electron multiplier array are designed so that each stage multiplies the number of emitted electrons by emitting multiple, new electrons. The greatly increased number of electrons emitted from one end of electron multiplier is collected by a positively charged anode at the other end, which creates a useable current signal. This current signal is amplified by the preamplifier board and then reported to the motherboard.

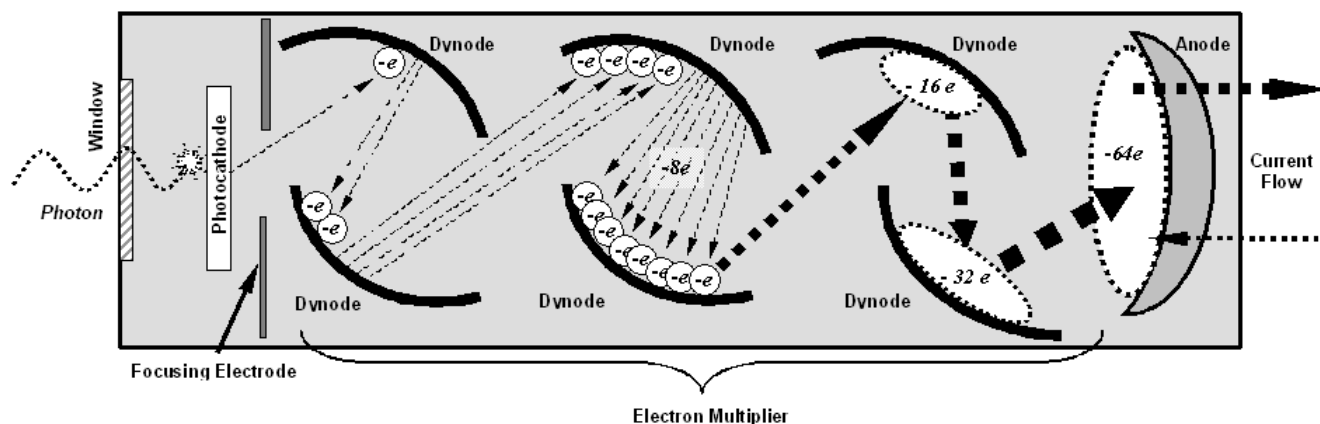

Figure 11-13: Basic PMT Design

A significant performance characteristic of the PMT is the voltage potential across the electron multiplier. The higher the voltage, the greater is the number of electrons emitted from each dynode of the electron multiplier, making the PMT more sensitive and responsive to small variations in light intensity but also more noisy (dark noise). The gain voltage of the PMT used in the 6200T is usually set between 450 V and 800 V. This parameter is viewable through the front panel as test function **HVPS** (refer to Section 4.1.1). For information on when and how to set this voltage, refer to Section 10.6.1.8.

The PMT is housed inside the PMT module assembly (refer to Figure 11-10 and Figure 11-12). This assembly also includes the high voltage power supply required to drive the PMT, an LED used by the instrument's optical test function, a thermistor that measures the temperature of the PMT and various components of the PMT cooling system including the Thermo-Electric Cooler (TEC).

#### 11.3.4. PMT Cooling System

The performance of the analyzer's PMT is significantly affected by temperature. Variations in PMT temperature are directly reflected in the signal output of the PMT. Also the signal to noise ratio of the PMT output is radically influenced by temperature as well. The warmer the PMT is, the noisier its signal becomes until the noise renders the concentration signal useless. To





alleviate this problem a special cooling system exists that maintains the PMT temperature at a stable, low level.

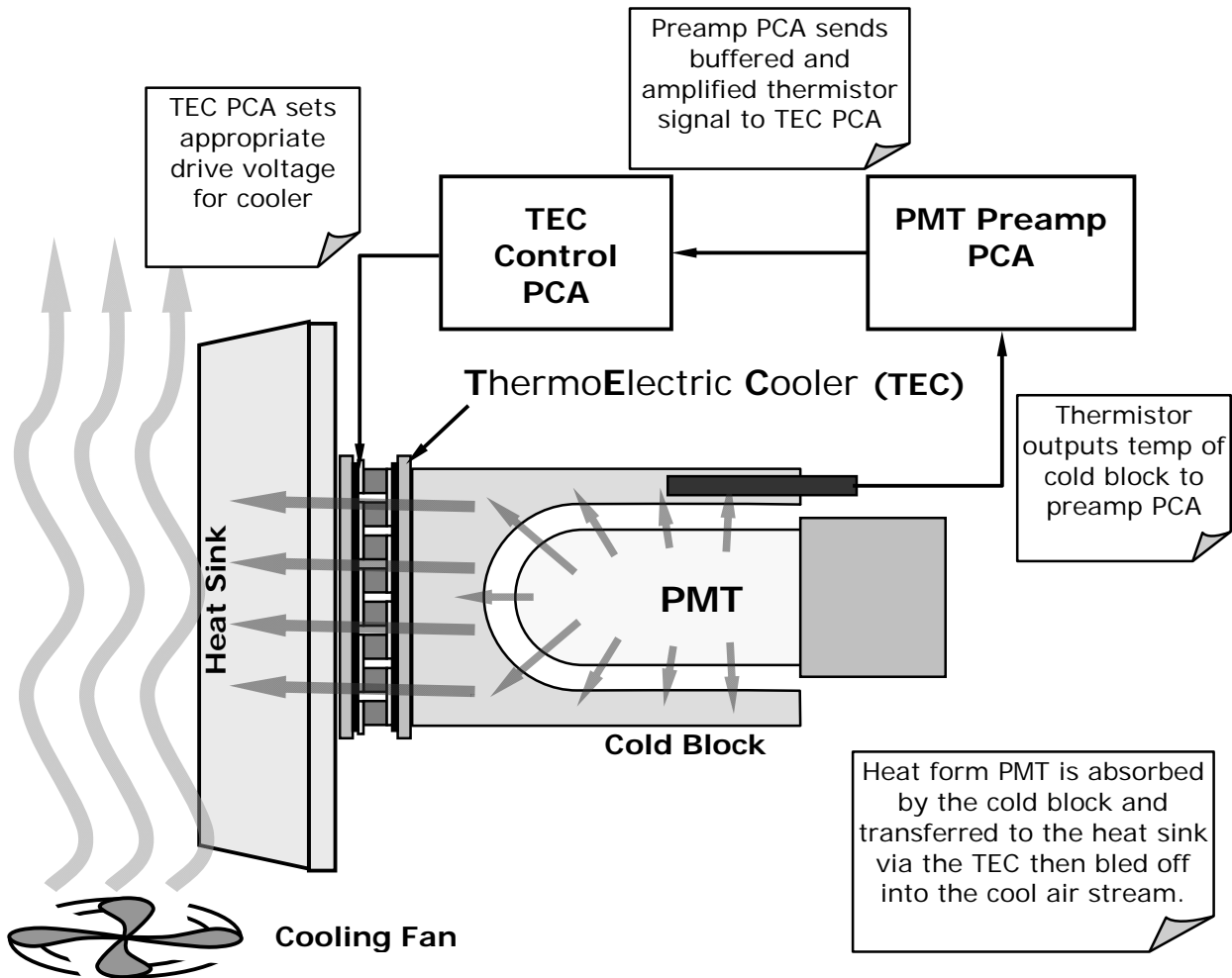

Figure 11-14: PMT Cooling System

#### 11.3.4.1. Thermoelectric Cooler (TEC)

The core of the 6200T PMT cooling system is a solid state heat pump called a thermoelectric cooler (TEC). Thermoelectric coolers transfer heat from a one side of a special set of semiconductor junctions to the other when a DC current is applied. The heat is pumped at a rate proportional to the amount of current applied. In the 6200T the TEC is physically attached to a cold block that absorbs heat directly from the PMT and a heat sink that is cooled by moving air (refer to Figure 11-14). A Thermocouple embedded into the cold block generates an analog voltage corresponding to the current temperature of the PMT. The PMT Preamp PCA conditions and amplifies this signal then passes it on to the TEC Control PCA.

#### 11.3.4.2. TEC Control Board

The TEC control printed circuit assembly is located on the sensor housing assembly, under the slanted shroud, next to the cooling fins and directly above the cooling fan. Using the amplified PMT temperature signal from the PMT preamplifier board (refer to Section 11.3.5), it sets the drive voltage for the thermoelectric cooler. The warmer the PMT gets, the more current is passed through the TEC causing it to pump more heat to the heat sink.

A red LED located on the top edge of this circuit board indicates that the control circuit is receiving power. Four test points are also located at the top of this assembly. For the definitions and acceptable signal levels of these test points refer to Section 10.1.2.

### 11.3.5. PMT Preamplifier

The PMT preamplifier board amplifies the PMT signal into a useable analog voltage that can be processed by the motherboard into a digital signal to be used by the CPU to calculate the SO<sub>2</sub> concentration of the gas in the sample chamber.

The output signal of the PMT is controlled by two different adjustments. First, the voltage across the electron multiplier array of the PMT is adjusted with a set of two hexadecimal switches. Adjusting this voltage directly affects the HVPS voltage and, hence, the signal from the PMT. Secondly, the gain of the amplified signal can further be adjusted through a potentiometer. These adjustments should only be performed when encountering problems with the software calibration that cannot be rectified otherwise. Refer to Section 10.6.1.8 for this hardware calibration.



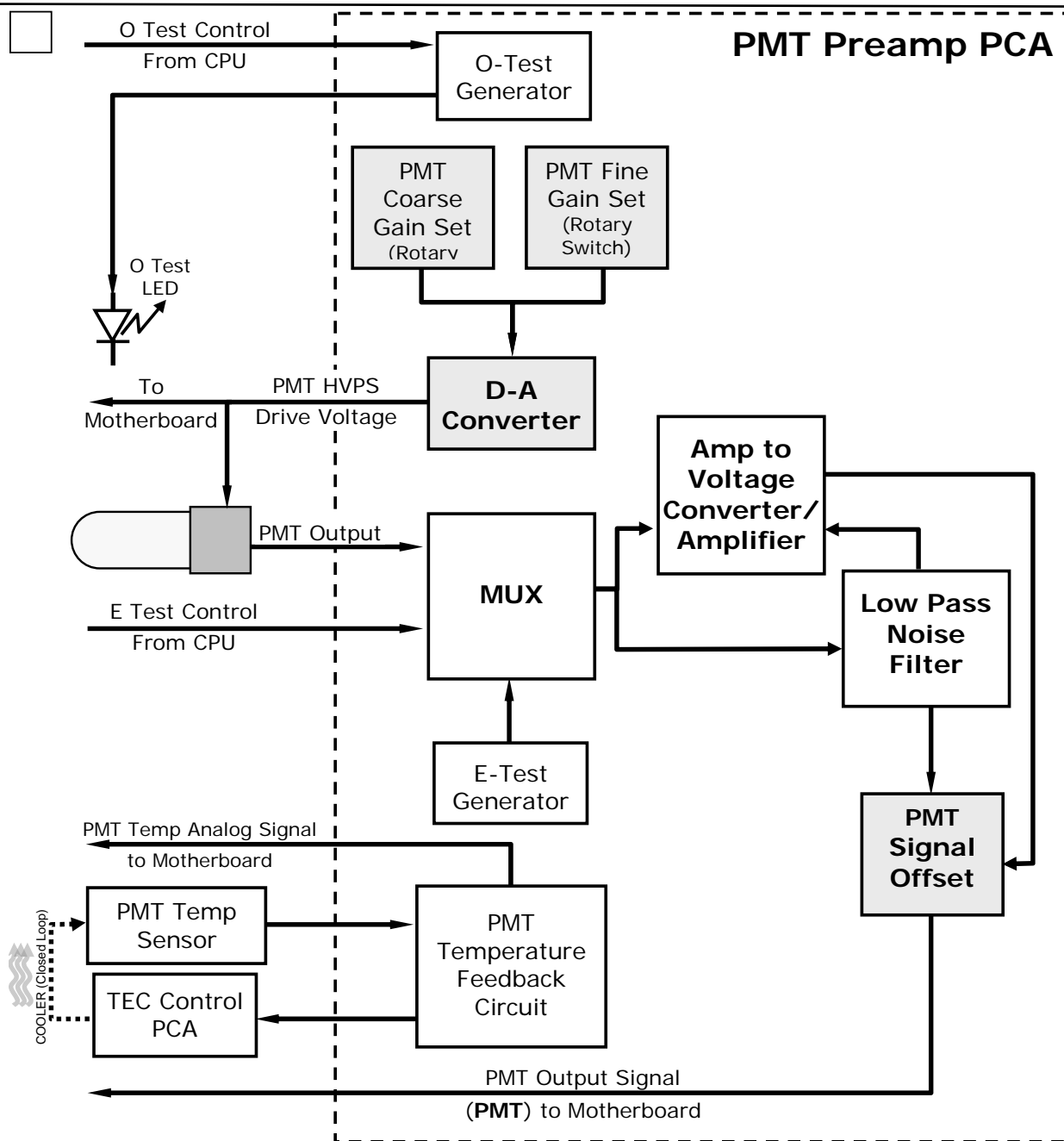

Figure 11-15: PMT Preamp Block Diagram

The PMT temperature control loop maintains the PMT temperature around 7° C and can be viewed as test function **PMT TEMP** on the front panel (refer to Section 4.1.1).

The electrical test (**ETEST**) circuit generates a constant, electronic signal intended to simulate the output of the PMT (after conversion from current to voltage). By bypassing the detector's actual signal, it is possible to test most of the signal handling and conditioning circuitry on the PMT preamplifier board. Refer to Section 5.9.5 for instructions on performing this test.

The optical test (**OTEST**) feature causes an LED inside the PMT cold block to create a light signal that can be measured with the PMT. If zero air is supplied to the analyzer, the entire measurement capability of the sensor module can be tested including the PMT and the current

to voltage conversion circuit on the PMT preamplifier board. Refer to Section 5.9.4 for instructions on performing this test.

### 11.3.6. Pneumatic Sensor Board

The flow and pressure sensors of the 6200T are located on a printed circuit assembly just behind the PMT sensor. Refer to Section 10.5.15 on how to test this assembly. The signals of this board are supplied to the motherboard for further signal processing. All sensors are linearized in the firmware and can be span calibrated from the front panel.

### 11.3.7. Relay Board

The relay board is the central switching unit of the analyzer. It contains power relays, status LEDs for all heated zones and valves, as well as valve drivers, thermocouple amplifiers, power distribution connectors and the two switching power supplies of the analyzer. The relay board communicates with the motherboard over the I<sup>2</sup>C bus and is the main board for trouble-shooting power problems of any kind.

#### 11.3.7.1. Heater Control

The 6200T uses a variety of heaters for its individual components. All heaters are AC powered and can be configured for 100/120 VAC or 220/230VAC at 50-60 Hz.

The two sample chamber heaters are electronically connected in parallel for analyzers at 100/120 VAC line power and in series for units configured for 220/230 VAC. One configuration plug on the relay board determines the power configuration for the entire analyzer.

On units with IZS options installed, an additional set of AC heaters is attached to the IZS permeation tube. Some special 6200T models may have other, non-standard heating zones installed, such as a dilution manifold.

#### 11.3.7.2. Valve Control

The relay board also hosts two valve driver chips, each of which can drive up four valves. In its basic configuration the 6200T requires no valve control to operate. However, on units with either the zero/span valve or the IZS option installed, the valve control is used. Manifold valves, which may also be present in certain special versions of the analyzer, would also use valve control.



11.3.7.3. Status LEDs & Watch Dog Circuitry

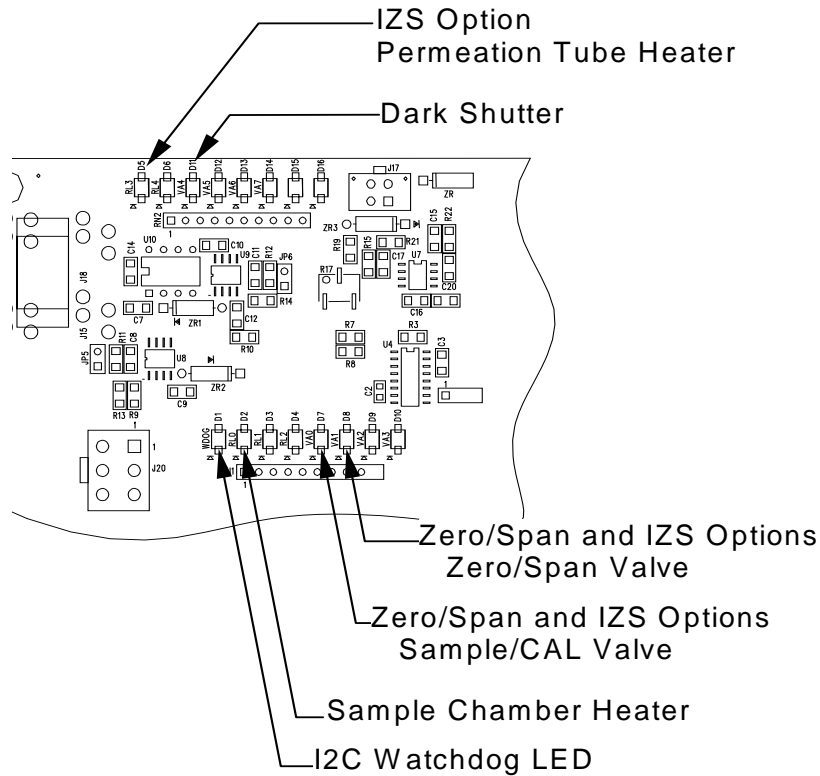

Figure 11-16: Relay Board Status LED Locations

Thirteen LEDs are located on the analyzer’s relay board to indicate the status of the analyzer’s heating zones and valves as well as a general operating watchdog indicator. Table 11-1 shows the state of these LEDs and their respective functionality.

Table 11-1: Relay Board Status LED’s

LED	COLOR	FUNCTION	STATUS WHEN LIT	STATUS WHEN UNLIT
D1	RED	Watchdog circuit	Cycles On/Off every 3 seconds under control of the CPU.	
D2	YELLOW	Sample chamber (RCELL) heater	HEATING	NOT HEATING
D3, D4	YELLOW	Unused	N/A	N/A
D5	YELLOW	IZS heater (option)	HEATING	NOT HEATING
D6	YELLOW	Unused	N/A	N/A
D7	GREEN	Zero / Span Valve	Valve open to Span Gas path	Valve open to Zero Gas (normal state)
D8	GREEN	Sample / Cal Valve	Valve open to calibration gas path	Valve open to sample gas inlet on rear panel (normal state)
D9, D10	GREEN	Unused	N/A	N/A
D11	GREEN	UV Lamp Shutter	Shutter open	Shutter closed
D12-14	GREEN	Unused	N/A	N/A

As a safety measure, special circuitry on the relay board watches the status of LED D1. Should this LED ever stay **ON** or **OFF** for 30 seconds, indicating that the CPU or I<sup>2</sup>C bus has stopped functioning, the Watchdog Circuit will automatically shut off all valves as well as turn off the UV Source(s) and all heaters. The Sample pump will still be running.

### 11.3.8. Motherboard

This printed circuit assembly provides a multitude of functions including A/D conversion, digital input/output, PC-104 to I<sup>2</sup>C translation, temperature sensor signal processing and is a pass through for the RS-232 and RS-485 signals.

#### 11.3.8.1. A to D Conversion

Analog signals, such as the voltages received from the analyzer's various sensors, are converted into digital signals that the CPU can understand and manipulate by the Analog to Digital converter (A/D). Under the control of the CPU, this functional block selects a particular signal input and then converts the selected voltage into a digital word.

The A/D consists of a Voltage-to-Frequency (V-F) converter, a Programmable Logic Device (PLD), three multiplexers, several amplifiers and some other associated devices. The V-F converter produces a frequency proportional to its input voltage. The PLD counts the output of the V-F during a specified time period, and sends the result of that count, in the form of a binary number, to the CPU.

The A/D can be configured for several different input modes and ranges but it is used in uni-polar mode with a +5V full scale. The converter includes a 1% over and under-range. This allows signals from -0.05V to +5.05V to be fully converted.

For calibration purposes, two reference voltages are supplied to the A/D converter: Reference ground and +4.096 VDC. During calibration, the device measures these two voltages, outputs their digital equivalent to the CPU. The CPU uses these values to compute the converter's offset and slope and uses these factors for subsequent conversions. Refer to Section 5.9.3.1 for instructions on performing this calibration.

#### 11.3.8.2. Sensor Inputs

The key analog sensor signals are coupled to the A/D through the master multiplexer from two connectors on the motherboard. 100K terminating resistors on each of the inputs prevent cross talk from appearing on the sensor signals.

**PMT DETECTOR OUTPUT:** This signal, output by the PMT preamp PCA, is used in the computation of the SO<sub>2</sub>, CO<sub>2</sub> and O<sub>2</sub> concentrations displayed in the front panel display screen and output through the instrument's analog outputs and **COMM** ports.

**PMT HIGH VOLTAGE POWER SUPPLY LEVEL:** This input is based on the drive voltage output by the PMT preamp board to the PMT's high voltage power supply (HVPS). It is digitized and sent to the CPU where it is used to calculate the voltage setting of the HVPS and stored in the instrument's memory as the test function **HVPS**. **HVPS** is viewable as a test function (refer to Section 4.1.1) through the analyzer's front panel.

**PMT TEMPERATURE:** This signal is the output of the thermistor attached to the PMT cold block amplified by the PMT temperature feedback circuit on the PMT preamp board. It is digitized and sent to the CPU where it is used to calculate the current temperature of the PMT.

This measurement is stored in the analyzer's memory as the test function **PMT TEMP** and is viewable as a test function (refer to Section 4.1.1) through the analyzer's front panel.

**SAMPLE GAS PRESSURE SENSOR:** This sensor measures the gas pressure at the exit of the sample chamber.

**SAMPLE FLOW SENSOR:** This sensor measures the flow rate of the sample gas as it exits the sample chamber.



### 11.3.8.3. Thermistor Interface

This circuit provides excitation, termination and signal selection for several negative-coefficient, thermistor temperature sensors located inside the analyzer. They are as follows:

**SAMPLE CHAMBER TEMPERATURE SENSOR:** The source of this signal is a thermistor imbedded in the of the sample chamber block. It measures the temperature of the sample gas in the chamber. The data are used by the CPU to control sample chamber the heating circuit and as part of the SO<sub>2</sub> calculations when the instrument's Temperature/Pressure Compensation feature is enabled.

This measurement is stored in the analyzer. Memory as the Test Function **RCEL TEMP** and is viewable as a test function (refer to Section 4.1.1) in the analyzer's front panel display.

**IZS OPTION PERMEATION TUBE TEMPERATURE SENSOR:** This thermistor, attached to the permeation tube in the IZS option, reports the current temperature of that tube to the CPU as part of control loop that keeps the tube at a constant temperature.

**BOX TEMPERATURE SENSOR:** A thermistor is attached to the motherboard. It measures the analyzer's internal temperature. This information is stored by the CPU and can be viewed by the user for troubleshooting purposes through the front panel display. This measurement is stored in the analyzer's memory as the test function **BOX TEMP** and is viewable as a test function (refer to Section 4.1.1) in the analyzer's front panel display.

### 11.3.9. Analog Outputs

The analyzer comes equipped with four Analog Outputs: **A1, A2, A3** and a fourth that is a spare. For more information, see the Configurable Analog Outputs Manual P/N MQ7859.

### 11.3.10. External Digital I/O

This External Digital I/O performs two functions.

**STATUS OUTPUTS:** Logic-Level voltages are output through an optically isolated 8-pin connector located on the rear panel of the analyzer. These outputs convey good/bad and on/off information about certain analyzer conditions. They can be used to interface with certain types of programmable devices (refer to Section 8.1.1).

**CONTROL INPUTS:** By applying +5VDC power supplied from an external source such as a PLC or Data logger (refer to Section 8.1.2), Zero and Span calibrations can be initiated by contact closures on the rear panel.

### 11.3.11. I<sup>2</sup>C Data Bus

I<sup>2</sup>C is a two-wire, clocked, bi-directional, digital serial I/O bus that is used widely in commercial and consumer electronic systems. A transceiver on the Motherboard converts data and control signals from the PC-104 bus to I<sup>2</sup>C. The data is then fed to the relay board and optional analog input circuitry.

### 11.3.12. Power up Circuit

This circuit monitors the +5V power supply during start-up and sets the Analog outputs, External Digital I/O ports, and I<sup>2</sup>C circuitry to specific values until the CPU boots and the instrument software can establish control.

### 11.3.13. Power Supply/ Circuit Breaker

The analyzer operates on 100 VAC, 115 VAC or 230 VAC power at either 50Hz or 60Hz. Individual units are set up at the factory to accept any combination of these five attributes. As illustrated in

Figure 11-17 below, power enters the analyzer through a standard IEC 320 power receptacle located on the rear panel of the instrument. From there it is routed through the ON/OFF switch located in the lower right corner of the front panel.

AC line power is converted stepped down and converted to DC power by two DC power supplies. One supplies +12 VDC, for various valves and valve options, while a second supply provides +5

VDC and  $\pm 15$  VDC for logic and analog circuitry as well as the TEC cooler. All AC and DC Voltages are distributed through the relay board.

A 6.75 ampere circuit breaker is built into the ON/OFF switch. In case of a wiring fault or incorrect supply power, the circuit breaker will automatically turn off the analyzer.

WARNING



**Should the power circuit breaker trip, correct the condition causing this situation before turning the analyzer back on.**

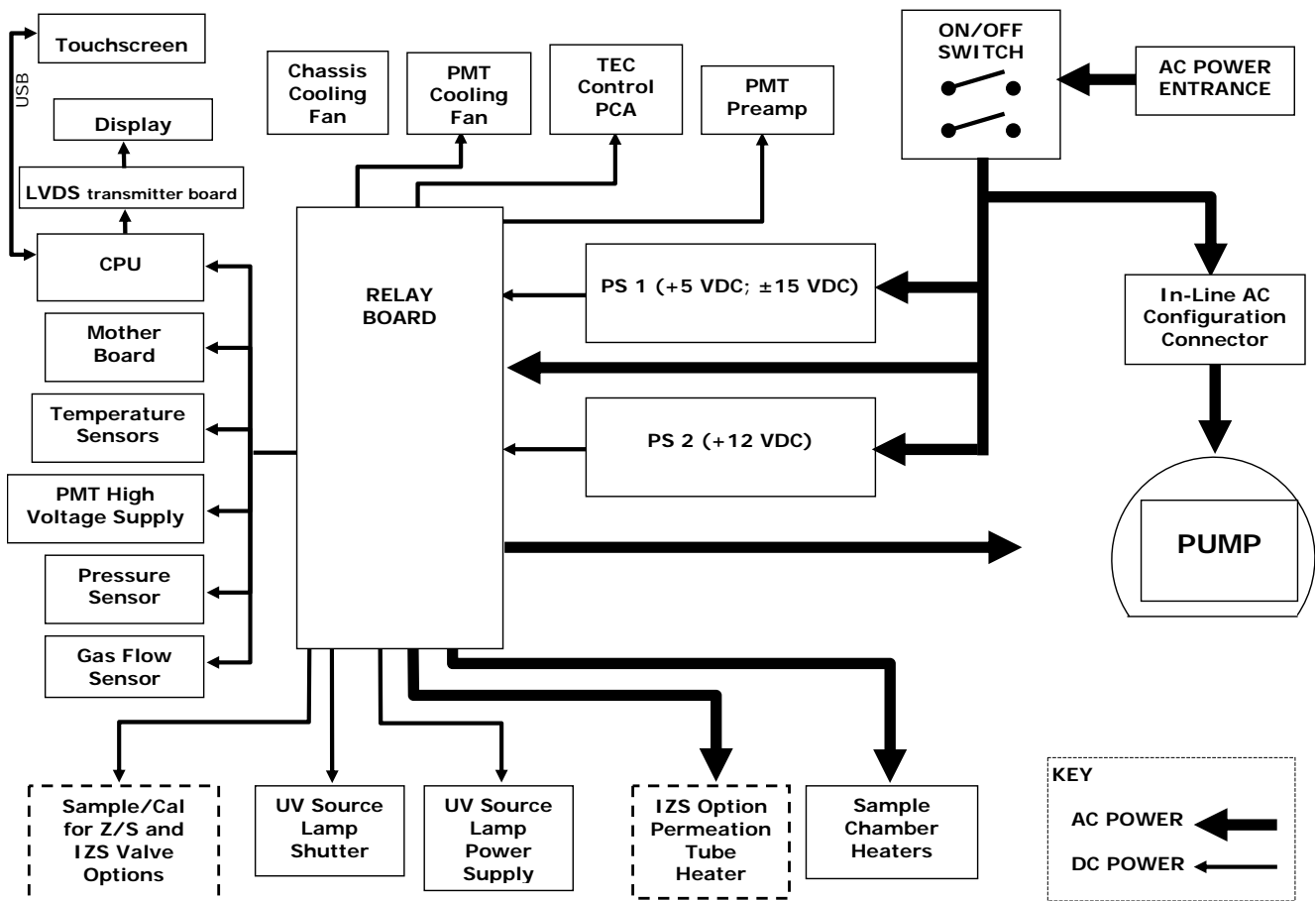

Figure 11-17: Power Distribution Block Diagram





### 11.4. Front Panel/Display Interface

Two types of Front Panel Display Interface used in Model 6200T. initially TS1 Version used in Model 6200T. later Model 6200T shipped with TS2 Version Front Panel Display Interface. Refer the below details of TS1 & TS2 interfaces.



Figure 11-2118: TS1, Front Panel Display

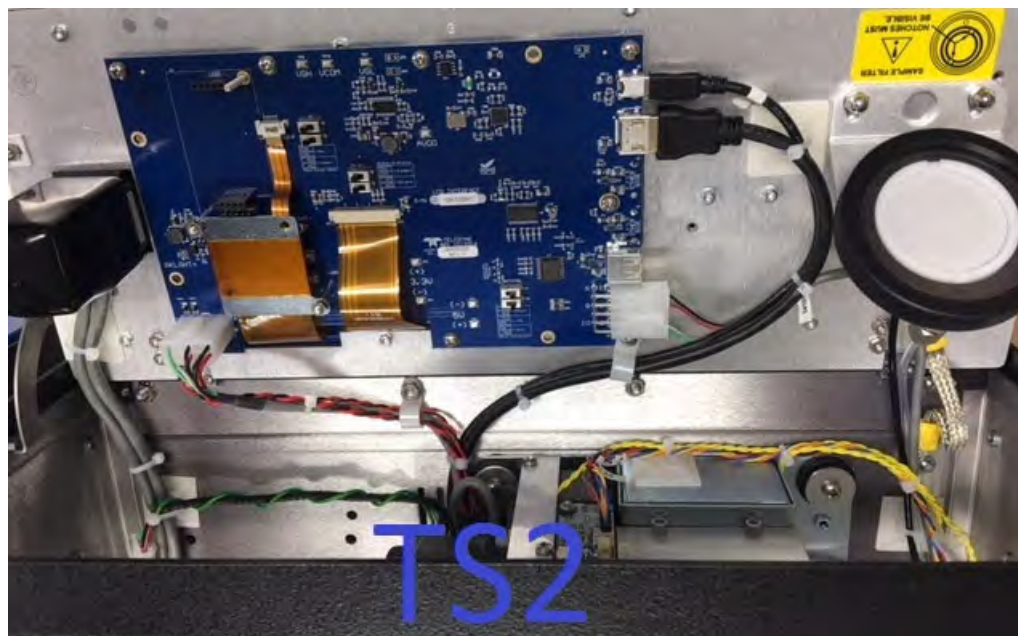

Figure 11-2219: TS2, Front Panel Display

Users can input data and receive information directly through the front panel touch-screen display. The LCD display is controlled directly by the CPU board. The touchscreen is interfaced to the CPU by means of a touchscreen controller that connects to the CPU via the internal USB bus and emulates a computer mouse.

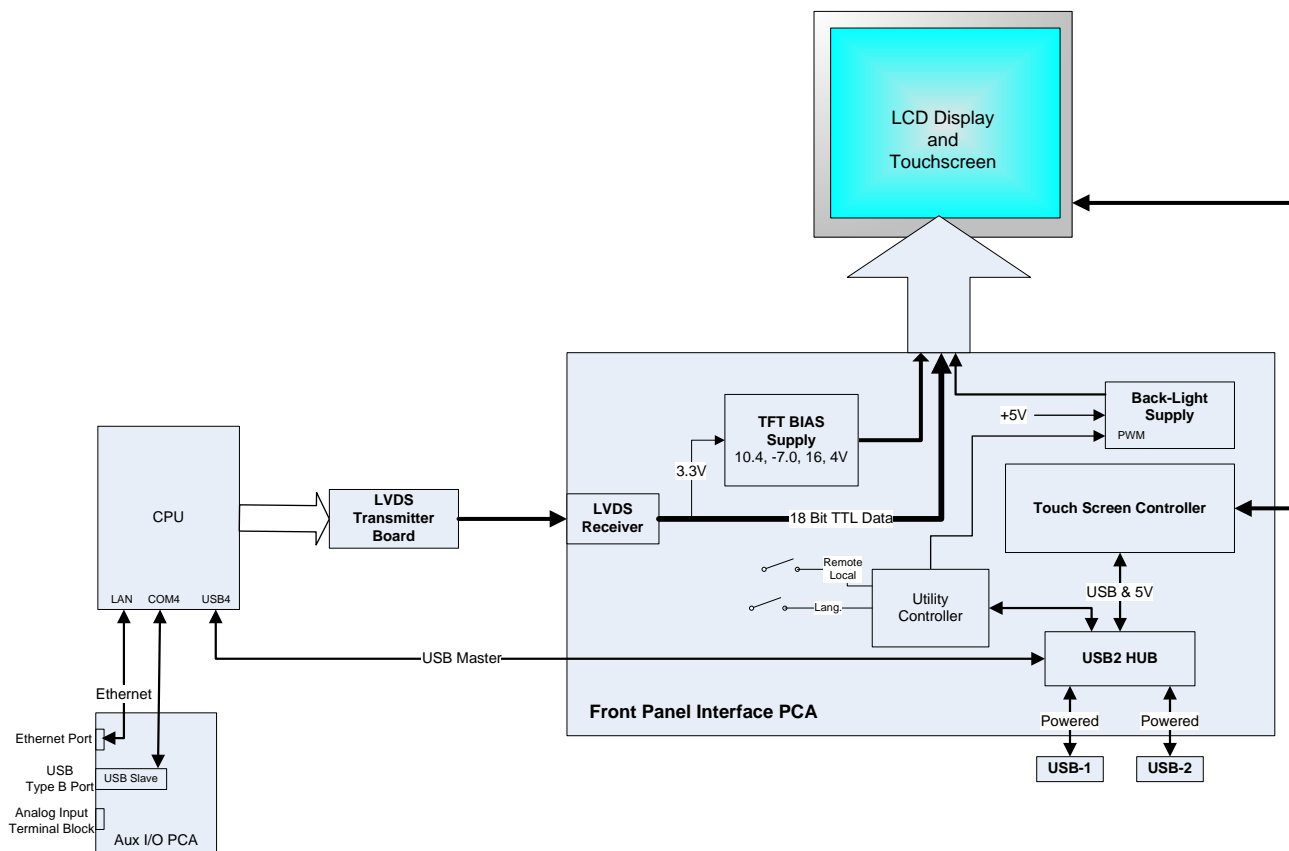

Figure 11-20: Front Panel and Display Interface Block Diagram

#### 11.4.1. LVDS Transmitter Board

The LVDS (low voltage differential signaling) transmitter board converts the parallel display bus to a serialized, low voltage, differential signal bus in order to transmit the video signal to the LCD interface PCA.

#### 11.4.2. Front Panel Interface PCA

The front panel interface PCA controls the various functions of the display and touchscreen. For driving the display it provides connection between the CPU video controller and the LCD display module. This PCA also contains:

- power supply circuitry for the LCD display module
- a USB hub that is used for communications with the touchscreen controller and the two front panel USB device ports
- the circuitry for powering the display backlight



### 11.4.3. TS1, Display Calibration Procedure

- The touchscreen display for the T series analyzer can be calibrated for the user's individual touch. To calibrate the display, you will need a USB keyboard. With the keyboard plugged into either USB port on the front panel, power off the instrument and then re-power.
- A Teledyne logo will appear and flash, wait until a logo appears again with the words **System Booting** and a loading bar appear below the logo, and hold down the left shift and left control key on the keyboard throughout the rest of the boot up. This may take several minutes to reach the destination screen.
- Once the screen becomes solid blue and a mouse cursor appears on the centre of the display, release the left shift and left control keys. A red and white target will appear near the centre of the screen. Press the target to start the calibration. The target will now appear in a different location. Press and hold each target following the instructions on the display until you are asked to hit either ACCEPT or CANCEL. Hit accept to accept the changes or cancel to decline the changes. After you hit accept, remove the keyboard and re-power the instrument.

### 11.4.4 How to Troubleshoot 6200T Display Touchscreen Issues

#### 11.4.4.1 How to Troubleshoot TS2 Touchscreen Display Issue.

1. Check both DC Voltages 3.3VDC and 5VDC are fine or not.
2. Connect a USB mouse to the front panel of the instrument. If you can actuate the buttons on the interface with the mouse but not with the touchscreen, then the touchscreen display itself (P/N 083500000) most likely is defective.
3. If the touchscreen is not working **and** the USB mouse does not actuate the buttons (freezing cursor), then try replacing P/N 066970000 PCA, INTRF. LCD TOUCH SCR, F/P.

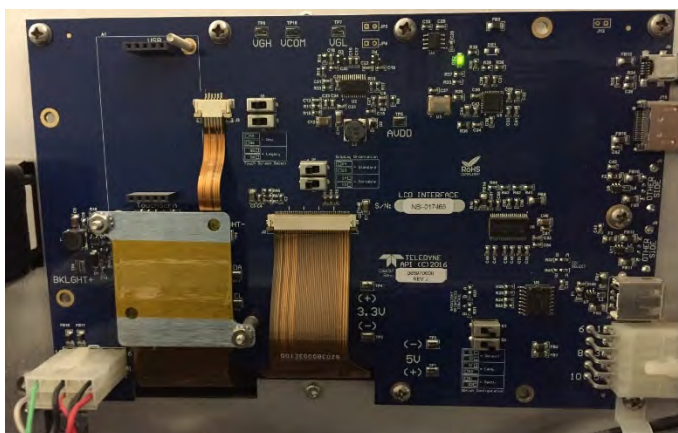

### 11.4.4.2 How to Troubleshoot TS1 Touchscreen Display Issue

The electronics used in TAI analyzers are sensitive to Electrostatic Discharge (ESD). When working on any TAI device, please ensure that you are properly grounded prior to handling or touching any electronic circuitry in the analyzers! For more information on how to protect sensitive components from ESD during handling,

#### REFERENCE: T SERIES TOUCH PANEL CALIBRATION

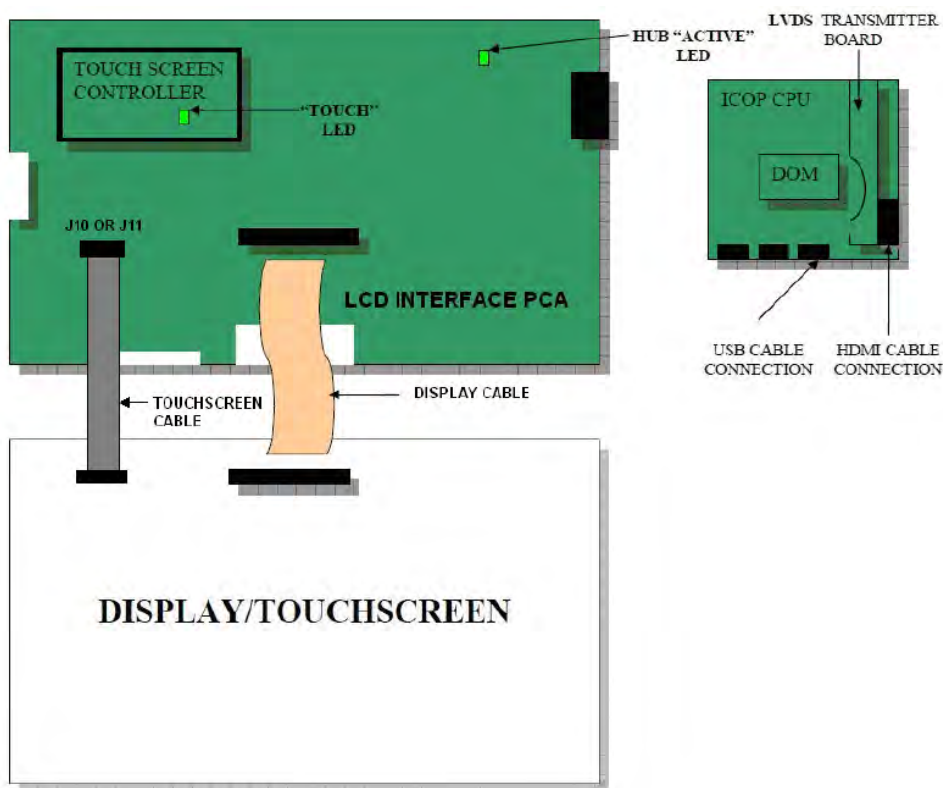

#### PROCEDURE

##### TOUCH SCREEN IS ERRATIC OR NOT CALIBRATED

Symptoms:

Buttons are unreliable.

Buttons may not respond when pressing on top of the actual button, but will respond when pressing off to one side of the actual button.

Actions:

- 1) Recalibrate the touch screen. (See reference section on page 1)
- 2) Replace the touch screen controller.

##### TOUCH SCREEN NOT RESPONDING

Symptoms:

A. Pointer may stay on.



During boot up you will notice a pointer on the display. Is on when you press a button on the touch screen.

B. "Touch" LED on touch screen controller never lights.

The "Touch" LED should blink anytime the front panel is pressed.

**Actions:**

1. If both the "Touch" LED and the "Hub Active" LED are OFF then with the power ON, check the USB cable (J9 of the LCD interface) to the CPU (see CPU connection above) and disconnect and reconnect the cable in either locations in attempt to reinitialize the hub. If this works you will hear two beeps, and see two flashes of the "Touch" LED on the touch screen controller.
2. If the "Touch" LED is inactive when touched (turns on when any area is pressed on front panel) but the "Hub Active" LED on the LCD INTERFACE PCA is ON then replace the Touch Screen. Controller.

## DISPLAY IS GREEN OR RAINBOW

**Symptoms:**

Display is green or rainbow coloured

**Actions:**

1. Power OFF instrument, verify that the ribbon cable from the display to the LCD INTERFACE BOARD is seated properly by gently lifting the brown tab (be careful as this connector is delicate), inspecting the connector, and then carefully re-inserting the cable pushing the cable into the socket and lowering the tab back into place. (J2 see below). Re-seat HDMI cable at the LCD INTERFACE PCA and at the CPU, and re-seat LVDS transmitter board on the CPU itself.
2. Reseat cable and turn ON instrument. Verify if display is working. If not working, then problem could be related to an I<sup>2</sup>C problem elsewhere in the instrument.

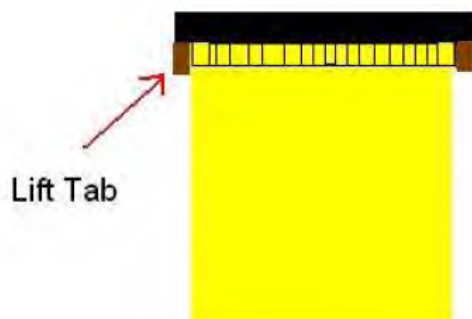

**Note:** TS2 Display, the Touchscreen control is integrated into the Display itself and there is no Calibration Menu available for this, as these Displays are self calibrating.

## 11.5. Software Operation

The instrument's core module is a high performance, X86-based microcomputer running Windows CE. Inside Windows CE, special software developed by Teledyne Analytical Instruments interprets user commands from the various interfaces, performs procedures and tasks, stores data in the CPU's various memory devices and calculates the concentration of the gas being sampled.

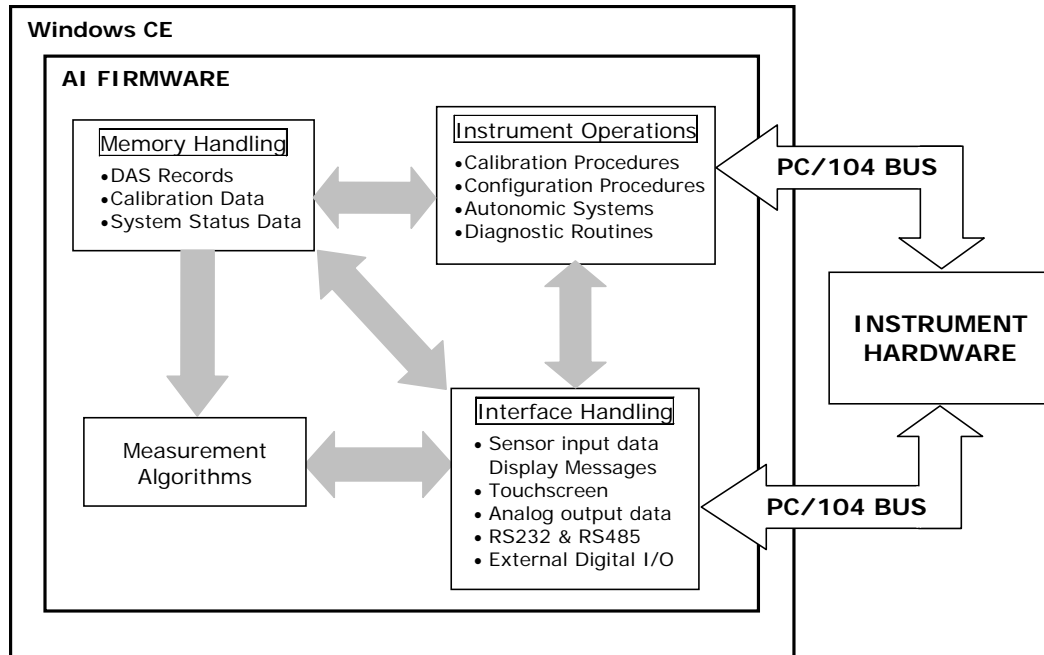

Figure 11-21: Basic Software Operation

### 11.5.1. Adaptive Filter

The 6200T TS analyzer software processes sample gas measurement and reference data through an adaptive filter built into the software. Unlike other analyzers that average the sensor output signal over a fixed time period, the 6200T calculates averages over a set number of samples where each sample is 1 second. During operation, the software automatically switches between two filters of different lengths based on the conditions at hand.

During conditions of constant or nearly constant concentration the software computes an average of the last 240 samples or 240 seconds. This provides the calculation portion of the software with smooth, stable readings. If a rapid change in concentration is detected, the adaptive filter switches modes and only averages the last 20 samples or 20 seconds. This allows the analyzer to respond to the rapidly changing concentration more quickly. Once triggered, the short filter remains engaged for a fixed time period to prevent chattering.

Two conditions must be simultaneously met to switch to the short filter. First the instantaneous concentration must exceed the average in the long filter by a fixed amount. Second, the instantaneous concentration must exceed the average in the long filter by a portion, or percentage, of the average in the long filter.

If necessary, these filter lengths of these two modes may be changed to any value between 1 and 1000 samples. Long sample lengths provide better signal to noise rejection, but poor response times. Conversely shorter filter lengths result in poor signal to noise rejection, but quicker response times.



### 11.5.2. Calibration - Slope and Offset

Calibration of the analyzer is performed exclusively in software. During instrument calibration the user enters expected values for zero and span through the front panel touch-screen control buttons and commands the instrument to make readings of sample gases with known concentrations of TS. The readings taken are adjusted, linearized, and compared to the expected values as input. With this information the software computes values for instrument both slope and offset and stores these values in memory for use in calculating the TS concentration of the sample gas.

Instrument slope and offset values recorded during the last calibration can be viewed by pressing the following control buttons sequence

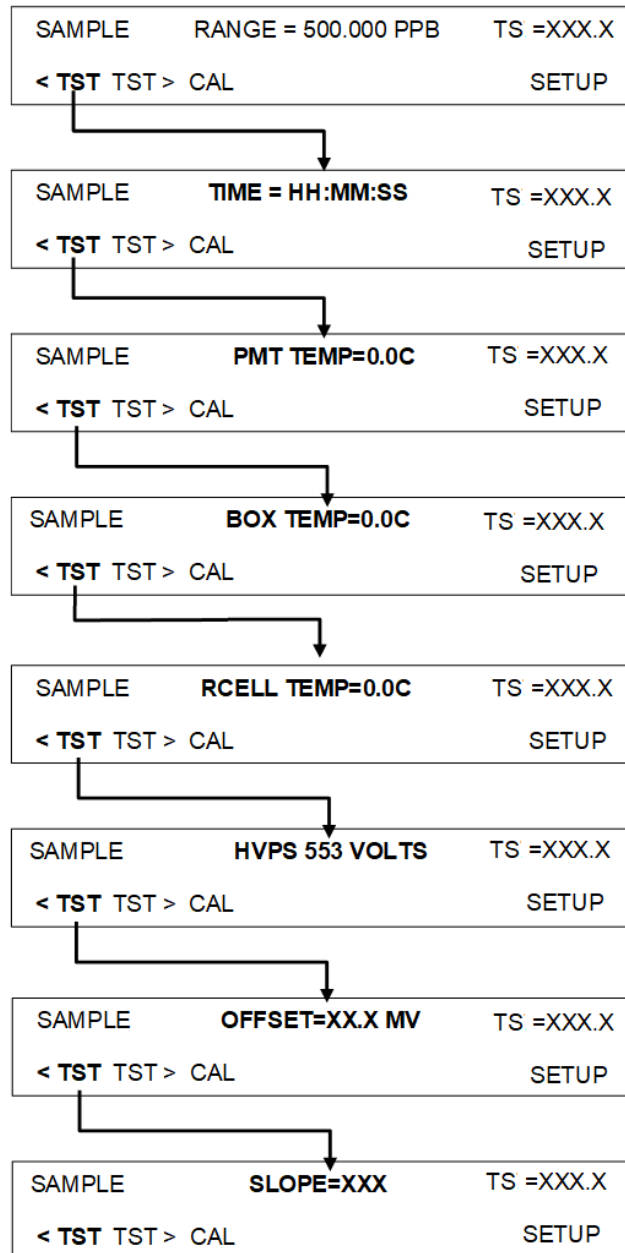

Figure 11-22: Calibration Slope and Offset

### 11.5.3. Temperature and Pressure Compensation (TPC) Feature

As explained in the principles of operation, changes in temperature can significantly affect the amount of fluoresced UV light generated in the instrument's sample chamber. To negate this effect the 6200T maintains the sample gas at a stable, raised temperature.

Pressure changes can also have a noticeable, if more subtle, effect on the TS concentration calculation. To account for this, the 6200T software includes a feature which allows the instrument to compensation of the TS calculations based on changes in ambient pressure.

When the TPC feature is enabled, the analyzer's TS concentration divided by a factor call PRESSCO which is based on the difference between the ambient pressure of the sample gas normalized to standard atmospheric pressure (Equation 11-6). As ambient pressure increases, the compensated TS concentration is decreased.

$$PRESSCO = \frac{SAMPLE\_PRESSURE (" HG - A) \times SAMP\_PRESS\_SLOPE}{29.92 (" HG - A)}$$

(Equation 11-6)

**SAMPLE-PRESSURE:** The ambient pressure of the sample gas as measured by the instrument's sample pressure sensor in "Hg-A.

**SAMP\_PRESS\_SLOPE:** Sample pressure slope correction factor. The default setting for Section 6.8 describes the method for enabling/disabling the TPC feature.

### 11.5.4. Internal Data Acquisition System (DAS)

The DAS is designed to implement predictive diagnostics that stores trending data for users to anticipate when an instrument will require service. Large amounts of data can be stored in non-volatile memory and retrieved in plain text format for further processing with common data analysis programs. The DAS has a consistent user interface in all Teledyne Analytical Instruments instruments. New data parameters and triggering events can be added to the instrument as needed.

Depending on the sampling frequency and the number of data parameters the DAS can store several months of data, which are retained even when the instrument is powered off or a new firmware is installed. The DAS permits users to access the data through the instrument's front panel or the remote interface. The latter can automatically download stored data for further processing. For information on using the DAS, refer to Section 0.





**This page intentionally left blank.**

## 12. GLOSSARY

Note: Some terms in this glossary may not occur elsewhere in this manual.

Term	Description/Definition
10Base-T	an Ethernet standard that uses twisted ("T") pairs of copper wires to transmit at 10 megabits per second (Mbps)
100Base-T	same as 10BaseT except ten times faster (100 Mbps)
APICOM	name of a remote control program offered by Teledyne-AI to its customers
ASSY	<i>Assembly</i>
CAS	<i>Code-Activated Switch</i>
CD	<i>Corona Discharge</i> , a frequently luminous discharge, at the surface of a conductor or between two conductors of the same transmission line, accompanied by ionization of the surrounding atmosphere and often by a power loss
CE	<i>Converter Efficiency</i> , the percentage of light energy that is actually converted into electricity
CEM	<i>Continuous Emission Monitoring</i>
Chemical formulas that may be included in this document:	
CO <sub>2</sub>	carbon dioxide
C <sub>3</sub> H <sub>8</sub>	propane
CH <sub>4</sub>	methane
H <sub>2</sub> O	water vapor
HC	general abbreviation for hydrocarbon
HNO <sub>3</sub>	nitric acid
H <sub>2</sub> S	hydrogen sulfide
NO	nitric oxide
NO <sub>2</sub>	nitrogen dioxide
NO <sub>x</sub>	nitrogen oxides, here defined as the sum of NO and NO <sub>2</sub>
NO <sub>y</sub>	nitrogen oxides, often called odd nitrogen: the sum of NO <sub>x</sub> plus other compounds such as HNO <sub>3</sub> (definitions vary widely and may include nitrate (NO <sub>3</sub> ), PAN, N <sub>2</sub> O and other compounds as well)

Term	Description/Definition
NH <sub>3</sub>	ammonia
O <sub>2</sub>	molecular oxygen
O <sub>3</sub>	ozone
SO <sub>2</sub>	sulfur dioxide
cm <sup>3</sup>	metric abbreviation for <i>cubic centimeter</i> (replaces the obsolete abbreviation "cc")
CPU	<i>Central Processing Unit</i>
DAC	<i>Digital-to-Analog Converter</i>
DAS	<i>Data Acquisition System</i>
DCE	<i>Data Communication Equipment</i>
DFU	<i>Dry Filter Unit</i>
DHCP	<i>Dynamic Host Configuration Protocol</i> . A protocol used by LAN or Internet servers to automatically set up the interface protocols between themselves and any other addressable device connected to the network
DIAG	<i>Diagnostics</i> , the diagnostic settings of the analyzer.
DOM	<i>Disk On Module</i> , a 44-pin IDE flash drive with up to 128MB storage capacity for instrument's firmware, configuration settings and data
DOS	<i>Disk Operating System</i>
DRAM	<i>Dynamic Random Access Memory</i>
DR-DOS	<i>Digital Research DOS</i>
DTE	<i>Data Terminal Equipment</i>
EEPROM	<i>Electrically Erasable Programmable Read-Only Memory</i> also referred to as a FLASH chip or drive
ESD	<i>Electro-Static Discharge</i>
ETEST	<i>Electrical Test</i>
Ethernet	a standardized (IEEE 802.3) computer networking technology for local area networks (LANs), facilitating communication and sharing resources
FEP	<i>Fluorinated Ethylene Propylene</i> polymer, one of the polymers that Du Pont markets as <i>Teflon</i> <sup>®</sup>
Flash	non-volatile, solid-state memory

Term	Description/Definition
FPI	<i>Fabry-Perot Interface</i> : a special light filter typically made of a transparent plate with two reflecting surfaces or two parallel, highly reflective mirrors
GFC	<i>Gas Filter Correlation</i>
I <sup>2</sup> C bus	a clocked, bi-directional, serial bus for communication between individual analyzer components
IC	<i>Integrated Circuit</i> , a modern, semi-conductor circuit that can contain many basic components such as resistors, transistors, capacitors etc in a miniaturized package used in electronic assemblies
IP	<i>Internet Protocol</i>
IZS	<i>Internal Zero Span</i>
LAN	<i>Local Area Network</i>
LCD	<i>Liquid Crystal Display</i>
LED	<i>Light Emitting Diode</i>
LPM	<i>Liters Per Minute</i>
MFC	<i>Mass Flow Controller</i>
M/R	<i>Measure/Reference</i>
MOLAR MASS	<p>the mass, expressed in grams, of 1 mole of a specific substance. Conversely, one mole is the amount of the substance needed for the molar mass to be the same number in grams as the atomic mass of that substance.</p> <p>EXAMPLE: The atomic weight of Carbon is 12 therefore the molar mass of Carbon is 12 grams. Conversely, one mole of carbon equals the amount of carbon atoms that weighs 12 grams.</p> <p>Atomic weights can be found on any Periodic Table of Elements.</p>
NDIR	<i>Non-Dispersive Infrared</i>
NIST-SRM	<i>National Institute of Standards and Technology - Standard Reference Material</i>
PC	<i>Personal Computer</i>
PCA	<i>Printed Circuit Assembly</i> , the PCB with electronic components, ready to use
PC/AT	<i>Personal Computer / Advanced Technology</i>
PCB	<i>Printed Circuit Board</i> , the bare board without electronic component
PFA	<i>Perfluoroalkoxy</i> , an inert polymer; one of the polymers that <i>Du Pont</i> markets as <i>Teflon</i> <sup>®</sup>
PLC	<i>Programmable Logic Controller</i> , a device that is used to control instruments based on a logic level signal coming from the analyzer

Term	Description/Definition
PLD	<i>Programmable Logic Device</i>
PLL	<i>Phase Lock Loop</i>
PMT	<i>Photo Multiplier Tube</i> , a vacuum tube of electrodes that multiply electrons collected and charged to create a detectable current signal
P/N (or PN)	<i>Part Number</i>
PSD	<i>Prevention of Significant Deterioration</i>
PTFE	<i>Polytetrafluoroethylene</i> , a very inert polymer material used to handle gases that may react on other surfaces; one of the polymers that <i>Du Pont</i> markets as <i>Teflon</i> <sup>®</sup>
PVC	<i>Poly Vinyl Chloride</i> , a polymer used for downstream tubing
Rdg	Reading
RS-232	specification and standard describing a serial communication method between DTE (Data Terminal Equipment) and DCE (Data Circuit-terminating Equipment) devices, using a maximum cable-length of 50 feet
RS-485	specification and standard describing a binary serial communication method among multiple devices at a data rate faster than RS-232 with a much longer distance between the host and the furthest device
SAROAD	<i>Storage and Retrieval of Aerometric Data</i>
SLAMS	<i>State and Local Air Monitoring Network Plan</i>
SLPM	<i>Standard Liters Per Minute</i> of a gas at standard temperature and pressure
STP	<i>Standard Temperature and Pressure</i>
TCP/IP	<i>Transfer Control Protocol / Internet Protocol</i> , the standard communications protocol for Ethernet devices
TEC	<i>Thermal Electric Cooler</i>
TPC	<i>Temperature/Pressure Compensation</i>
USB	<i>Universal Serial Bus</i> : a standard connection method to establish communication between peripheral devices and a host controller, such as a mouse and/or keyboard and a personal computer or laptop
VARS	<i>Variables</i> , the variable settings of the instrument
V-F	<i>Voltage-to-Frequency</i>
Z/S	<i>Zero / Span</i>

## 13. SPARE PARTS

This section presents the Spare Parts Lists for the 6200T. Please note that the internal scrubber cartridge takes a special scrubber material. TAI's standard Sox scrubber material is not appropriate for use in the internal scrubber assembly. The external scrubber does take standard scrubber material.

### 13.1. Spare Parts and Annual Maintenance Kit

**Table 13-1. 6200T Spare Parts List, (Reference: 01/07/2020)**

S.No	P/N	Description
1	000940100	"CD, ORIFICE, .003 GREEN (KB)"
2	000940300	"CD, ORIFICE, .020 VIOLET"
3	000940400	"CD, ORIFICE, .004 BLUE (KB)"
4	000940800	"CD, ORIFICE, .012 (NO PAINT) (KB)"
5	000941200	"CD, ORIFICE, .008, RED/NONE"
6	002690000	"CD, LENS, PL-CON (PA)"
7	002700000	"CD, LENS, BI-CON (KB)"
8	5960000	"AKIT, EXP, ACT CHARCOAL, (2 BTL@64 FL-OZ EA)"
9	009690000	"AKIT, TFE FLTR ELEM (FL6 100=1) 47mm"
10	009690100	"AKIT, TFE FLTR ELEM (FL6, 30=1) 47mm"
11	013140000	"ASSY, COOLER FAN (NOX/SOX, E/T)"
12	013210000	"ASSY, VACUUM MANIFOLD, SOx"
13	013390000	"ASSY, KICKER"
14	013400000	"CD, PMT, SOx, (R1527) (PA)"
15	013420000	"ASSY, ROTARY SOLENOID"
16	014080100	"ASSY, HVPS, SOX/NOX, AMB"
17	014400100	"OPTION, ZERO AIR SCRUBBER"
18	014750000	"ANNUAL MAINTENANCE KIT, IZS, T10x, T10xU"
19	016290000	"WINDOW, SAMPLE FILTER, 47MM (KB)"
20	016300700	"ASSY, SAMPLE FILTER, 47MM, ANG BKT"
21	025730000	"ASSY, HEATSINK/COOLER"
22	037100000	"TUBE, CONVERTER (PA)"
23	040010000	"ASSY, FAN REAR PANEL (B/F)"
24	041620100	"ASSY, SO2 SENSOR, AMB (KB)"
25	041800400	"PCA, PMT PREAMP, SOx"
26	043570000	"ANNUAL MAINTENANCE KIT, T100, T101, & T102"
27	045230200	"PCA, RELAY CARD"
28	046250000	"ASSY, RXCELL HEATER/SWITCH"
29	046260000	"ASSY, THERMISTOR, RXCELL (KB)"
30	050630100	"PCA, UV DET, w/OP20, DUAL OUT, 100"
31	055560000	"ASSY, VALVE, VA59 W/DIODE, 5" LEADS"
32	058021100	"PCA, MTHEBD, GEN 5-ICOP (PA)"
33	062610100	"ANNUAL MAINTENANCE KIT, T108"
34	066970000	"PCA, INTRF. LCD TOUCH SCRNM, F/P"
35	067240000	"CPU, PC-104, V SX-6154E, ICOP, T SERIES, LEGACY, (PA) *"

S.No	P/N	Description
36	068810000	"PCA, LVDS TRANSMITTER BOARD"
37	072150000	"ASSY. TOUCHSCREEN CONTROL MODULE"
38	073210400	PCA, PNEU SNSOR BD, 15PA, 1LPM, (PA)
39	075880000	"PCA, PMT TEC COOLER DRIVER(PA)"
40	077480200	"ASSY, PMP, INT, Univ-V, 6 OC"
41	079390000	"PCA, UV LAMP DRIVER, CONST CURR"
42	081730000	"CPU, PC-104, VDX-6534RD, ICOP, T SERIES, NVS (PA) *"
43	083500000	"LCD MODULE, W/TOUCHSCREEN, TS2 (PA)"
44	089200000	"ASSY, OMRON CONTROLLER, W/SOFTWARE, 501TS"
45	FL0000001	"FILTER, SS"
46	FL0000003	"FILTER, DFU (PA)"
47	HW0000020	"SPRING (VMI)"
48	KIT000093	"AKIT, REPLCMNT(3187)214NM FLTR (BF)"
49	KIT000095	"AKIT, REPLACEMENT COOLER"
50	KIT000136	"REBUILD, RXCELL, CD FILTER 330NM (00272)"
51	KIT000137	"AKIT, REBUILD, RXCELL, CD FILTER 360NM ("
52	KIT000219	"AKIT, 4-20MA CURRENT OUTPUT"
53	KIT000236	"KIT, UV LAMP, w/ADAPTER (BIR)"
54	KIT000253	"ASSY & TEST, SPARE PS37"
55	KIT000254	"ASSY & TEST, SPARE PS38"
56	KIT000255	"AKIT, RETROFIT, M501TS, TC TYPE S RPLCMN"
57	KIT000369	"KIT, PNEU SNSR BD, 15PA, 1LPM, SOx, SEALED"
58	KIT000383	"KIT, UPDATE, TS1 TO TS2, DISPLAY"
59	KIT000387	"DOM, REPLACEMENT, E SERIES, *"
60	KIT000388	"DOM, REPLACEMENT, T SERIES, LEGACY, TS1, *"
61	KIT000389	"DOM, REPLACEMENT, T SERIES, NVS, *"
62	KIT000390	"KIT, RETROFIT, LEGACY TO NVS, WITH TS2 *"
63	OR0000001	"ORING, 2-006VT *(PA)"
64	***	"REBUILD KIT
65	RL0000020	"SSRT RELAY, TD2410, CE MARK (PA)"
66	SW0000058	"SWITCH, THERMAL, 450 DEG F"
67	SW0000059	"SENSOR, PRES, 0-15, PSIA, ALL SENS"

\*\*\*

REFER STICKER INSTALLED ON PUMP HEAD TO GET REBUILT KIT P/N

Table 13-2. 6200T, 2 YEARS RECOMMENDED SPARES LIST (Reference: 01/07/2020)

S.No	P/N	Description	Qty
1	013140000	"ASSY, COOLER FAN (NOX/SOX, E/T)"	1
2	040010000	"ASSY, FAN REAR PANEL (B/F)"	1
3	041800400	"PCA, PMT PREAMP, SOX"	1
4	062610100	"ANNUAL MAINTENANCE KIT, T108"	1
5	***	"KIT REBUILT, PUMP"	1
6	079390000	"PCA, UV LAMP DRIVER, CONST CURR"	1
7	FLO000003	"FILTER, DFU (PA)"	2
8	KIT000236	"KIT, UV LAMP, w/ADAPTER (BIR)"	1
9	KIT000253	"ASSY & TEST, SPARE PS37"	1
10	KIT000254	"ASSY & TEST, SPARE PS38"	1
11	KIT000255	"AKIT, RETROFIT, M501TS, TC TYPE S RPLCMN"	1
12	037100000	"TUBE, CONVERTER (PA)", 501TS	1
13	073210400	PCA, PNEU SNSOR BD, 15PA, 1LPM, (PA)	1
	***	PUMP REBUILT KIT SHOULD BE AS PER PUMP SUPPLIED WITH SYSTEM	

Table 13.3, P/N 062610100, MAINTENANCE KIT HAVING BELOW ITEMS

S.No	ITEM NUMBER	ITEM DESCRIPTION	QTY
1	005960000	ACTIVATED CHARCOAL, (2 BTL@64 FL-OZ EACH)	1
2	009690000	TEFLON FILTER ELEMENT (FL6, QTY 30) 47mm	1
3	018080000	DESSICANT BAGGIES (QTY 12)	1
4	039620100	IMPREG CHARCOAL, TS	1
5	FLO000001	FILTER, SS (KB)	2
6	HW0000020	SPRING	2
7	OR0000001	ORING, FLOW CONTROL	4
8	000940300	CD, ORIFICE, .020 VIOLET	1
9	000941200	CD, ORIFICE, .008 RED/NONE	1
10	000940800	CD, ORIFICE, .012 NO PAINT	1