

Use and Disclosure of Data

Information contained herein is classified as EAR99 under the
U.S. Export Administration Regulations.
Export, reexport or diversion contrary to U.S. law is prohibited.

Operation Manual for

Model GFC 7000T

CO₂ Analyzer



P/N M90878
DATE 10/06/16

TELEDYNE ELECTRONIC TECHNOLOGIES

Analytical Instruments

16830 Chestnut Street
City of Industry, CA 91748
Telephone: (626) 934-1500
Fax: (626) 961-2538
Web: www.teledyne-ai.com

DECLARATION OF CONFORMITY

Teledyne declares that the products specified below meet the current health and safety requirements of the above mentioned European Directives. Representative instrumentation has been tested by an NRTL certified test lab and is individually identified with the CE mark.

Product description: Model GFC7000T

Serial number: Each instrument has an identifiable serial number

Year of Construction: Each Instrument has an identifiable year of construction

Power Requirements: Each Instrument has power requirements specified on instrument labeling.

Applicable Standards: (Directive 2004/108/EC): EN61326-1
(Direction 2006/95/EC): EN61010-1 (3rd Edition)

I, THE UNDERSIGNED, HEREBY DECLARE THAT THE EQUIPMENT SPECIFIED ABOVE CONFORMS TO THE ABOVE STANDARD(S):

SIGNATURE:  _____

FULL NAME: Steve Broy

POSITION: Director of Engineering

DATE: 7-1-14

PLACE: City of Industry, California

Copyright © 2016 Teledyne Analytical Instruments

All Rights Reserved. No part of this manual may be reproduced, transmitted, transcribed, stored in a retrieval system, or translated into any other language or computer language in whole or in part, in any form or by any means, whether it be electronic, mechanical, magnetic, optical, manual, or otherwise, without the prior written consent of Teledyne Analytical Instruments, 16830 Chestnut Street, City of Industry, CA 91748.

Warranty

This equipment is sold subject to the mutual agreement that it is warranted by us free from defects of material and of construction, and that our liability shall be limited to replacing or repairing at our factory (without charge, except for transportation), or at customer plant at our option, any material or construction in which defects become apparent within one year from the date of shipment, except in cases where quotations or acknowledgements provide for a shorter period. Components manufactured by others bear the warranty of their manufacturer. This warranty does not cover defects caused by wear, accident, misuse, neglect or repairs other than those performed by Teledyne or an authorized service center. We assume no liability for direct or indirect damages of any kind and the purchaser by the acceptance of the equipment will assume all liability for any damage which may result from its use or misuse.

We reserve the right to employ any suitable material in the manufacture of our apparatus, and to make any alterations in the dimensions, shape or weight of any parts, in so far as such alterations do not adversely affect our warranty.

Important Notice

This instrument provides measurement readings to its user, and serves as a tool by which valuable data can be gathered. The information provided by the instrument may assist the user in eliminating potential hazards caused by his process; however, it is essential that all personnel involved in the use of the instrument or its interface be properly trained in the process being measured, as well as all instrumentation related to it.

The safety of personnel is ultimately the responsibility of those who control process conditions. While this instrument may be able to provide early warning of imminent danger, it has no control over process conditions, and it can be misused. In particular, any alarm or control systems installed must be tested and understood, both as to how they operate and as to how they can be defeated. Any safeguards required such as locks, labels, or redundancy, must be provided by the user or specifically requested of Teledyne at the time the order is placed.

Therefore, the purchaser must be aware of the hazardous process conditions. The purchaser is responsible for the training of personnel, for providing hazard warning methods and instrumentation per the appropriate standards, and for ensuring that hazard warning devices and instrumentation are maintained and operated properly.

Teledyne Analytical Instruments, the manufacturer of this instrument, cannot accept responsibility for conditions beyond its knowledge and control. No statement expressed or implied by this document or any information disseminated by the manufacturer or its agents, is to be construed as a warranty of adequate safety control under the user's process conditions.

Trademarks

All trademarks, registered trademarks, brand names or product names appearing in this document are the property of their respective owners and are used herein for identification purposes only.

ABOUT THIS MANUAL

This manual describes operation, specifications, and maintenance for the Model GFC 7000T.

In addition this manual contains important SAFETY messages for this instrument. It is strongly recommended that you read that operation manual in its entirety before operating the instrument.

This page intentionally left blank.

SAFETY MESSAGES

Important safety messages are provided throughout this manual for the purpose of avoiding personal injury or instrument damage. Please read these messages carefully. Each safety message is associated with a safety alert symbol, and are placed throughout this manual; the safety symbols are also located inside the instrument. **It is imperative that you pay close attention to these messages, the descriptions of which are as follows:**



WARNING: Electrical Shock Hazard



HAZARD: Strong oxidizer



GENERAL WARNING/CAUTION: Read the accompanying message for specific information.



CAUTION: Hot Surface Warning



Do Not Touch: Touching some parts of the instrument without protection or proper tools could result in damage to the part(s) and/or the instrument.



Technician Symbol: All operations marked with this symbol are to be performed by qualified maintenance personnel only.



Electrical Ground: This symbol inside the instrument marks the central safety grounding point for the instrument.

CAUTION



This instrument should only be used for the purpose and in the manner described in this manual. If you use this instrument in a manner other than that for which it was intended, unpredictable behavior could ensue with possible hazardous consequences.

NEVER use any gas analyzer to sample combustible gas(es)!

Note: Technical Assistance regarding the use and maintenance of the GFC7001TA or any other Teledyne product can be obtained by contacting Teledyne Customer Service Department:

Phone: 888-789-8168

Email: ask_tai@teledyne.com

or by accessing various service options on our website at

<http://www.teledyne-ai.com/>



CONSIGNES DE SÉCURITÉ

Des consignes de sécurité importantes sont fournies tout au long du présent manuel dans le but d'éviter des blessures corporelles ou d'endommager les instruments. Veuillez lire attentivement ces consignes. Chaque consigne de sécurité est représentée par un pictogramme d'alerte de sécurité; ces pictogrammes se retrouvent dans ce manuel et à l'intérieur des instruments. Les symboles correspondent aux consignes suivantes :



AVERTISSEMENT : Risque de choc électrique



DANGER : Oxydant puissant



AVERTISSEMENT GÉNÉRAL / MISE EN GARDE : Lire la consigne complémentaire pour des renseignements spécifiques



MISE EN GARDE : Surface chaude



Ne pas toucher : Toucher à certaines parties de l'instrument sans protection ou sans les outils appropriés pourrait entraîner des dommages aux pièces ou à l'instrument.



Pictogramme « technicien » : Toutes les opérations portant ce symbole doivent être effectuées uniquement par du personnel de maintenance qualifié.



Mise à la terre : Ce symbole à l'intérieur de l'instrument détermine le point central de la mise à la terre sécuritaire de l'instrument.

MISE EN GARDE



Cet instrument doit être utilisé aux fins décrites et de la manière décrite dans ce manuel. Si vous utilisez cet instrument d'une autre manière que celle pour laquelle il a été prévu, l'instrument pourrait se comporter de façon imprévisible et entraîner des conséquences dangereuses.

NE JAMAIS utiliser un analyseur de gaz pour échantillonner des gaz combustibles!

TABLE OF CONTENTS

SAFETY MESSAGES	v
CONSIGNES DE SÉCURITÉ.....	vi
TABLE OF CONTENTS	vii
1. INTRODUCTION.....	1
1.1. Features	1
1.2. Using This Manual.....	2
2. SPECIFICATIONS AND APPROVALS	5
2.1. Specifications	5
3. GETTING STARTED	7
3.1. Unpacking and Initial Set Up	7
3.2. Front Panel.....	9
3.3. Rear Panel	13
3.4. Internal Layout	15
3.5. Electrical Connections	16
3.5.1. Power Connection	17
3.5.2. Connecting Analog Inputs (Option 64).....	17
3.5.3. Connecting Analog Outputs.....	18
3.5.4. Connecting the Status Outputs.....	20
3.5.5. Connecting the Control Inputs	21
3.5.6. Connecting the Communications Interfaces	22
3.5.7. Alarms	22
3.6. Pneumatic Connections	23
3.6.1. Basic Pneumatic Connections	23
3.6.2. Connections with Internal Valve Options Installed.....	27
3.6.3. Pneumatic Connections in Multipoint Calibration Applications.....	29
3.6.4. Setting the Internal Purge Air Pressure	29
3.7. Initial Operation	30
3.7.1. Startup	30
3.7.2. Warm Up.....	31
3.7.3. Warning Messages	31
3.7.4. Functional Check.....	33
3.8. Initial Calibration Procedure	34
3.8.1. Initial O ₂ Sensor Calibration Procedure	37
4. FREQUENTLY ASKED QUESTIONS	41
4.1. FAQ's	41
4.2. Glossary	42
5. OPTIONAL HARDWARE AND SOFTWARE	47
5.1. Rack Mount Kits (Options 20A, 20B, 21 and 23).....	47
5.2. Current Loop Analog Outputs (Option 41).....	47
5.2.1. Converting Current Loop Analog Outputs to Standard Voltage Outputs.....	48
5.3. Expendable Kits (Options 42C, 42D and 43).....	49
5.4. Calibration Valves Options	50
5.5. Communication Options	51
5.5.1. Communications Cables.....	51
5.5.2. RS-232 Multidrop (Option 62).....	51
5.6. Oxygen Sensor (OPT 65).....	52
5.6.1. Theory of Operation.....	52
5.7. Special Features	55
5.7.1. Dilution Ratio Option.....	55
5.7.2. Maintenance Mode Switch.....	55
5.7.3. Second Language Switch	55
6. OPERATING INSTRUCTIONS.....	57
6.1. Overview of Operating modes	57
6.2. Sample Mode	58
6.2.1. Test Functions	59
6.2.2. Warning Messages	61
6.3. Calibration Mode	62
6.4. SETUP MODE.....	63
6.5. SETUP → CFG: Viewing the Analyzer's Configuration Information	64

6.6. SETUP → ACAL: Automatic Calibration	64
6.7. SETUP → DAS: Using the Data Acquisition System (DAS)	65
6.7.1. DAS Structure	66
6.7.2. Default DAS Channels	68
6.7.3. Remote DAS Configuration	82
6.8. SETUP → RNGE: Analog Output Reporting Range Configuration	83
6.8.1. Physical Range versus Analog Output Reporting Ranges	84
6.8.2. Reporting Range Modes	84
6.8.3. Single Range Mode (SNGL)	86
6.8.4. Dual Range Mode (DUAL)	87
6.8.5. Auto Range Mode (AUTO)	88
6.8.6. Range Units	89
6.8.7. Dilution Ratio	90
6.9. SETUP → PASS: Password Feature	91
6.10. SETUP → CLK: Setting the Internal Time-of-Day Clock	93
6.11. SETUP → MORE → COMM: Using the Analyzer's Communication Ports	95
6.11.1. Analyzer ID	95
6.11.2. COM Port Default Settings	96
6.11.3. RS-485 Configuration of COM2	99
6.11.4. DTE and DCE Communication	99
6.11.5. COM Port Communication Modes	100
6.11.6. Remote Access via the Ethernet	102
6.11.7. Multidrop RS-232 Set Up	108
6.11.8. COM Port Baud Rate	110
6.11.9. COM Port Testing	111
6.12. SETUP → MORE → VARS: Internal Variables (VARS)	112
6.13. SETUP → MORE → DIAG: Using the Diagnostics Functions	114
6.13.1. Accessing the Diagnostic Features	115
6.13.2. Signal I/O	115
6.13.3. Analog Output Step Test	116
6.13.4. Analog I/O Configuration	117
6.13.5. Electric Test	130
6.13.6. Dark Calibration Test	131
6.13.7. Pressure Calibration	132
6.13.8. Flow Calibration	133
6.13.9. Test Channel Output	134
6.14. SETUP → MORE → ALRM: Using the Gas Concentration Alarms	135
6.14.1. Setting the Concentration Alarm Limits	136
6.15. Remote Operation of the Analyzer	136
6.15.1. Remote Operation Using the External Digital I/O	136
6.15.2. Remote Operation Using the External Serial I/O	140
7. CALIBRATION PROCEDURES	147
7.1. Before Calibration	147
7.1.1. Zero Air and Span Gas	147
7.1.2. Calibration Gas Traceability	148
7.1.3. Data Recording Devices	148
7.2. Manual Calibration without Zero/Span Valves	148
7.3. Manual Calibration Checks	152
7.4. Manual Calibration with Zero/Span Valves	153
7.5. Manual Calibration Checks with Zero/Span Valves	156
7.5.1. Zero/Span Calibration on Auto Range or Dual Ranges	157
7.5.2. Use of Zero/Span Valves with Remote Contact Closure	158
7.6. Automatic Zero/Span Cal/Check (AutoCal)	158
7.6.1. AutoCal with Auto or Dual Reporting Ranges Modes Selected	161
7.7. Calibration Quality	161
8. MAINTENANCE SCHEDULE & PROCEDURES	163
8.1. Maintenance Schedule	163
8.2. Predicting Failures Using the Test Functions	167
8.3. Maintenance Procedures	168
8.3.1. Replacing the Sample Particulate Filter	168
8.3.2. Performing Leak Checks	169
8.3.3. Performing a Sample Flow Check	170

8.3.4. Cleaning the Optical Bench	170
8.3.5. Cleaning Exterior Surfaces of the GFC 7000T	170
9. THEORY OF OPERATION	171
9.1. Measurement Method	171
9.1.1. Beer's Law	171
9.1.2. Measurement Fundamentals	171
9.1.3. Gas Filter Correlation	172
9.1.4. Interference and Signal to Noise Rejection	174
9.2. Pneumatic Operation	177
9.2.1. Sample Gas Flow	177
9.2.2. Flow Rate Control	177
9.2.3. Critical Flow Orifice	178
9.2.4. Purge Gas Pressure Control	179
9.2.5. Particulate Filter	179
9.2.6. Pneumatic Sensors	179
9.3. Electronic Operation	180
9.3.1. Overview	180
9.3.2. CPU	182
9.3.3. Optical Bench & GFC Wheel	183
9.3.4. Synchronous Demodulator (Sync/Demod) Assembly	185
9.3.5. Relay Board	188
9.3.6. Mother Board	190
9.3.7. I ² C Data Bus	193
9.3.8. Power Supply/ Circuit Breaker	194
9.4. Front Panel Touchscreen/Display Interface	195
9.4.1. LVDS Transmitter Board	195
9.4.2. Front Panel Touchscreen/Display Interface PCA	195
9.5. Software Operation	196
9.5.1. Adaptive Filter	196
9.5.2. Calibration - Slope and Offset	197
9.5.3. Measurement Algorithm	197
9.5.4. Temperature and Pressure Compensation	198
9.5.5. Internal Data Acquisition System (DAS)	198
10. TROUBLESHOOTING & REPAIR PROCEDURES	199
10.1. General Troubleshooting Hints	199
10.1.1. Interpreting WARNING Messages	200
10.1.2. Fault Diagnosis with TEST Functions	203
10.1.3. Using the Diagnostic Signal I/O Function	205
10.1.4. Internal Electronic Status LEDs	206
10.2. Gas Flow Problems	210
10.2.1. GFC 7000T Internal Gas Flow Diagrams	211
10.2.2. Typical Sample Gas Flow Problems	213
10.2.3. Poor or Stopped Flow of Purge Gas	214
10.3. Calibration Problems	215
10.3.1. Miscalibrated	215
10.3.2. Non-Repeatable Zero and Span	216
10.3.3. Inability to Span – Touchscreen SPAN Button Not Visible	216
10.3.4. Inability to Zero – Touchscreen ZERO Button Not Visible	216
10.4. Other Performance Problems	217
10.4.1. Temperature Problems	217
10.4.2. Excessive Noise	219
10.5. Subsystem Checkout	220
10.5.1. AC Mains Configuration	220
10.5.2. DC Power Supply	220
10.5.3. I ² C Bus	221
10.5.4. Touchscreen Interface	221
10.5.5. LCD Display Module	221
10.5.6. Relay Board	222
10.5.7. Sensor Assembly	222
10.5.8. Motherboard	224
10.5.9. CPU	227
10.5.10. RS-232 Communications	227

10.6. Repair Procedures	229
10.6.1. Removing/Replacing the GFC Wheel	229
10.6.2. Disk-On-Module Replacement Procedure	230
11. A PRIMER ON ELECTRO-STATIC DISCHARGE.....	233
11.1. How Static Charges are Created.....	233
11.2. How Electro-Static Charges Cause Damage	234
11.3. Common Myths About ESD Damage	235
11.4. Basic Principles of Static Control.....	235

LIST OF APPENDICES

APPENDIX A - VERSION SPECIFIC SOFTWARE DOCUMENTATION, L.8

APPENDIX A-1: Models GFC 7000T and GFC 7000E Software Menu Trees

APPENDIX A-2: GFC 7000 Series Setup Variables

APPENDIX A-3: GFC 7000 Series Warnings and Test Measurements

APPENDIX A-4: GFC 7000 Series Signal I/O Definitions

APPENDIX A-5: GFC 7000 Series DAS Triggering Events

APPENDIX A-6: GFC 7000 Series DAS Parameters

APPENDIX A-7: Terminal Command Designators

APPENDIX A-8: Terminal Key Assignments

APPENDIX B - SPARE PARTS LIST and RECOMMENDED SPARES STOCKING LEVELS

APPENDIX C - REPAIR QUESTIONNAIRE

APPENDIX D - ELECTRONIC SCHEMATICS



LIST OF FIGURES

Figure 3-1:	Front Panel Layout	9
Figure 3-2:	Display Screen and Touch Control	10
Figure 3-3:	Display/Touch Control Screen Mapped to Menu Charts	12
Figure 3-4:	Rear Panel Layout.....	13
Figure 3-5:	Internal Chassis Layout.....	15
Figure 3-6:	Optical Bench Layout	16
Figure 3-7:	Analog Input Connector.....	17
Figure 3-8:	Status Connector.....	20
Figure 3-9:	Internal Gas Flow–Basic Configuration.....	26
Figure 3-10:	Pneumatic Connections with Zero/ Span Valves (OPT 50A).....	27
Figure 3-11:	Pneumatic Connections with Zero/Span Valves (Opt 50A) and External Zero Air Scrubber	28
Figure 3-12:	Example of Pneumatic Set up for Multipoint Calibration.....	29
Figure 3-13:	O2 Sensor Calibration Set Up	37
Figure 5-1:	Current Loop Option Installed on the Motherboard.....	48
Figure 5-2:	Internal Pneumatic Flow –with Zero/Span Valve Option.....	51
Figure 5-3:	Multi-drop/LVDS PCA Seated on CPU	52
Figure 5-4:	Oxygen Sensor - Principle of Operation.....	53
Figure 5-5:	GFC 7000T – Internal Pneumatics with O2 Sensor Option 65	54
Figure 6-1:	Front Panel Display	57
Figure 6-2:	Viewing TEST Functions	60
Figure 6-3:	Viewing and Clearing GFC 7000T WARNING Messages	62
Figure 6-4:	Default DAS Channels Setup	69
Figure 6-5:	APICOM User Interface for DAS Configuration	82
Figure 6-6:	Analog Output Connector Pin Out.....	83
Figure 6-7:	Rear Panel Connector Pin-Outs for COM1 & COM2 in RS-232 Mode	97
Figure 6-8:	CPU Connector Pin-Outs for COM1 & COM2 in RS-232 Mode	98
Figure 6-9:	Multidrop/LVDS PCA Seated on CPU.....	108
Figure 6-10:	RS232-Multidrop PCA Host/Analyzer Interconnect Diagram.....	109
Figure 6-11:	Setup for Calibrating Analog Voltage Outputs	124
Figure 6-12:	Setup for Calibrating Current Outputs	126
Figure 6-13:	Status Output Connector.....	137
Figure 6-14:	Control Inputs	139
Figure 6-15:	APICOM Remote Control Program Interface	145
Figure 7-1:	Pneumatic Connections–Basic Configuration–Using Bottled Span Gas	149
Figure 7-2:	Pneumatic Connections–Basic Configuration–Using Gas Dilution Calibrator	149
Figure 7-3:	Pneumatic Connections – Zero/ Span Valves.....	153
Figure 7-4:	Pneumatic Connections – Ambient Zero/Pressurized Span Valves and External Zero Air Scrubber	153
Figure 8-1:	Sample Particulate Filter Assembly	168
Figure 9-1:	Measurement Fundamentals.....	172
Figure 9-2:	GFC Wheel.....	172
Figure 9-3:	Measurement Fundamentals with GFC Wheel	173
Figure 9-4:	Affect of CO2 in the Sample on CO2 MEAS & CO2 REF	174
Figure 9-5:	Effects of Interfering Gas on CO2 MEAS & CO2 REF	175
Figure 9-6:	Chopped IR Signal	175
Figure 9-7:	Internal Pneumatic Flow – Basic Configuration	177
Figure 9-8:	Flow Control Assembly & Critical Flow Orifice	178
Figure 9-9:	GFC 7000T Electronic Block Diagram	181
Figure 9-10:	CPU Board	182
Figure 9-11:	GFC Light Mask	184
Figure 9-12:	Segment Sensor and M/R Sensor Output.....	185
Figure 9-13:	GFC 7000T Sync / Demod Block Diagram	186



Figure 9-14:	Sample & Hold Timing.....	187
Figure 9-15:	Location of relay board Status LED's.....	190
Figure 9-16:	Power Distribution Block Diagram.....	194
Figure 9-17:	Front Panel and Display Interface Block Diagram.....	195
Figure 9-18:	Basic Software Operation.....	196
Figure 10-1:	Viewing and Clearing Warning Messages.....	201
Figure 10-2:	Example of Signal I/O Function.....	206
Figure 10-3:	CPU Status Indicator.....	207
Figure 10-4:	Sync/Demod Board Status LED Locations.....	208
Figure 10-5:	Relay Board Status LEDs.....	208
Figure 10-6:	GFC 7000T – Basic Internal Gas Flow.....	211
Figure 10-7:	Internal Pneumatic Flow –Zero/Span Valves.....	212
Figure 10-8:	Internal Pneumatic Flow – with O ₂ Sensor Option 65A.....	213
Figure 10-11:	Opening the GFC Wheel Housing.....	229
Figure 10-12:	Removing the GFC Wheel.....	230
Figure 11-1:	Triboelectric Charging.....	233
Figure 11-2:	Basic anti-ESD Work Station.....	236

LIST OF TABLES

Table 2-1:	Model GFC 7000T Specifications and Agency Approvals.....	5
Table 3-1:	Display and Touchscreen Control Description.....	11
Table 3-2:	Rear Panel Description.....	14
Table 3-3:	Analog Input Pin Assignments.....	18
Table 3-4:	GFC 7000T Analog Output Pin Outs.....	19
Table 3-5:	Status Output Pin-outs.....	20
Table 3-6:	Control Input Pin-outs.....	21
Table 3-7:	Rear Panel Pneumatic Connections.....	24
Table 3-8:	Front Panel Display During System Warm-Up.....	31
Table 3-9:	Possible Warning Messages at Start-Up.....	32
Table 5-1:	Zero/Span Valve Operating States.....	50
Table 6-1:	Analyzer Operating modes.....	58
Table 6-2:	Test Functions Defined.....	59
Table 6-3:	List of Warning Messages.....	61
Table 6-4:	Primary Setup Mode Features and Functions.....	63
Table 6-5:	Secondary Setup Mode Features and Functions.....	63
Table 6-6:	Front Panel Sample LED Status Indicators for DAS.....	65
Table 6-7:	DAS Data Channel Properties.....	66
Table 6-8:	DAS Data Parameter Functions.....	67
Table 6-9:	Password Levels.....	91
Table 6-10:	Com Port Communication Modes.....	100
Table 6-11:	Ethernet Status Indicators.....	102
Table 6-12:	LAN/Internet Configuration Properties.....	103
Table 6-13:	Internet Configuration Touchscreen Functions.....	107
Table 6-14:	Variable Names (VARS) Revision B.3.....	112
Table 6-15:	GFC 7000T Diagnostic (DIAG) Functions.....	114
Table 6-16:	DIAG - Analog I/O Functions.....	117
Table 6-17:	Analog Output Voltage Ranges.....	118
Table 6-18:	Analog Output Current Loop Range.....	119
Table 6-19:	Analog Output Pin Assignments.....	119
Table 6-20:	Voltage Tolerances for Analog Output Calibration.....	123
Table 6-21:	Current Loop Output Calibration with Resistor.....	127
Table 6-22:	Test Parameters Available for Analog Output A4.....	134
Table 6-23:	CO ₂ Concentration Alarm Default Settings.....	135
Table 6-24:	Status Output Pin Assignments.....	138



Table 6-25: Control Input Pin Assignments	139
Table 6-26: Terminal Mode Software Commands	140
Table 6-27: Command Types	141
Table 7-1: AUTOCAL Modes	158
Table 7-2: AutoCal ATTRIBUTE Setup Parameters	158
Table 7-3: Calibration Data Quality Evaluation	161
Table 8-1: GFC 7000T Maintenance Schedule	165
Table 8-2: GFC 7000T Test Function Record	166
Table 8-3: Predictive uses for Test Functions	167
Table 9-1: Sync/Demod Status LED Activity	187
Table 9-2: Relay Board Status LED's	189
Table 10-1: Warning Messages - Indicated Failures	202
Table 10-2: Test Functions - Indicated Failures	204
Table 10-3: Sync/Demod Board Status Failure Indications	207
Table 10-4: I2C Status LED Failure Indications	208
Table 10-5: Relay Board Status LED Failure Indications	209
Table 10-6: DC Power Test Point and Wiring Color Codes	220
Table 10-7: DC Power Supply Acceptable Levels	221
Table 10-8: Relay Board Control Devices	222
Table 10-9: Opto Pickup Board Nominal Output Frequencies	223
Table 10-10: Analog Output Test Function - Nominal Values Voltage Outputs	225
Table 10-11: Analog Output Test Function - Nominal Values Current Outputs	225
Table 10-12: Status Outputs Check	226
Table 11-1: Static Generation Voltages for Typical Activities	233
Table 11-2: Sensitivity of Electronic Devices to Damage by ESD	234

This page intentionally left blank.

1. INTRODUCTION

The GFC 7000T is a sophisticated instrument designed to measure carbon dioxide (CO₂) by comparing infrared energy absorbed by a sample to that absorbed by a reference according to the Beer-Lambert law. It uses a Gas Filter Wheel which alternately allows a high energy infrared light source to pass through a CO₂ filled chamber and a chamber with no CO₂ present.

The light then travels through the sample cell, which has a folded path. The energy loss through the sample cell is compared with the zero reference signal provided by the gas filter to produce an output proportional to concentration, with little effect from interfering gases within the sample. When required, a nitrogen purge system is provided for the GFC wheel assembly to eliminate the effects of ambient CO₂.

This design produces superior zero and span stability and a high signal-to-noise ratio, allowing excellent sensitivity. Multi-tasking software gives real time indication of numerous operating parameters and provides automatic alarms if diagnostic limits are exceeded

The Model GFC 7000T CO₂ Analyzer is related to other models in Teledyne's GFC instrument offering. For instance, the Model GFC 7000T is a close derivative of the Model GFC 7000TA CO₂ Analyzer with the main differences as follows:

- The optical bench is longer (14 m), making the instrument more sensitive at low CO₂ levels. The instrument has a user-selectable full scale range of 0-100 PPB to 0-100 PPM of CO₂.
- The rear panel is different. There is an extra pneumatic port for the exhaust of the purge gas to the GFC wheel. Also, there are relay alarm outputs available on the rear panel.

This manual covers the model GFC 7000T for pressurized applications. Other applications or modifications may be present and if so, an Addendum to this manual is included at the front which describes the modifications made to the Model GFC 7000T and any operational details and specifications that change as a result.

1.1. Features

- Ranges: User selectable to any full scale range from 0-2 ppm to 0-2,000 ppm
- Gas Filter Wheel for CO₂ specific measurement
- LCD Graphical User Interface with capacitive touch screen
- Multi-tasking software allows viewing of test variables during operation
- Continuous self checking with alarms
- Bi-directional RS-232 and 10/100Base-T Ethernet (optional USB and RS-485) ports for remote operation
- Front panel USB ports for peripheral devices
- Digital status outputs to indicate instrument operating condition
- Adaptive signal filtering to optimize response time
- Temperature & Pressure compensation
- Internal data logging with 1 min to 24 hour averages

1.2. Using This Manual

This manual has the following data structures:

1 TABLE OF CONTENTS:

Outlines the contents of the manual in the order the information is presented. This is a good overview of the topics covered in the manual. There is also a list of tables, a list of figures and a list of appendices.

2 SPECIFICATIONS

This section contains a list of the analyzer's performance specifications. See also the Addendum in the front of this manual.

3 GETTING STARTED:

Instructions for setting up, installing, and performing a functional check and initial calibration.

4 FAQ

Answers to the most frequently asked questions about operating the analyzer.

5 OPTIONAL HARDWARE & SOFTWARE

A description of optional equipment to add functionality to your analyzer.

6 OPERATION INSTRUCTIONS

This section includes step-by-step instructions for operating the analyzer and using its various features and functions.

7 CALIBRATION PROCEDURES

General information and step by step instructions for calibrating your analyzer.

8 EPA PROTOCOL CALIBRATION

Because CO₂ is not declared a criteria air pollutant by the US EPA, EPA equivalency is not required for this type of analyzer. Therefore no special calibration methods are needed to satisfy EPA requirements.

9 INSTRUMENT MAINTENANCE

Description of certain preventative maintenance procedures that should be regularly performed on you instrument to keep it in good operating condition. This section also includes information on using the DAS to record diagnostic functions useful in predicting possible component failures before they happen.

10 THEORY OF OPERATION

An in-depth look at the various principals by which your analyzer operates as well as a description of how the various electronic, mechanical and pneumatic components of the instrument work and interact with each other. A close reading of this section is invaluable for understanding the instrument's operation.

11 TROUBLESHOOTING

This section includes pointers and instructions for diagnosing problems with the instrument, such as excessive noise or drift, as well as instructions on performing repairs of the instrument's major subsystems.

12. A PRIMER ON ELECTRO-STATIC DISCHARGE

Very important information on how static electricity occurs, why it is so dangerous to electronic components and assemblies as well as how to prevent that damage from occurring.

APPENDICES:



These include: software menu trees, warning messages, definitions of DAS & serial I/O variables, spare parts list, repair questionnaire, interconnect listing and drawings, and electronic schematics.

NOTE

<p>Throughout this manual, words printed in capital, bold letters, such as SETUP or ENTR represent messages as they appear on the analyzer's front panel display. Also, flowcharts in this manual contain typical representations of the analyzer's display during the various operations being described. These representations are not intended to be exact and may differ slightly from the actual display of your instrument.</p>
--



This page intentionally left blank.

2. SPECIFICATIONS AND APPROVALS

2.1. Specifications

Table 2-1: Model GFC 7000T Specifications and Agency Approvals

PARAMETER	SPECIFICATION
Ranges	User selectable to any full scale range from 0-2 ppm to 0-2,000 ppm
Measurement Units	ppb, ppm, $\mu\text{g}/\text{m}^3$, mg/m^3 (user selectable)
Zero Noise	< 0.1 ppm RMS
Span Noise	< 1% of reading RMS
Lower Detectable Limit	< 0.2 ppm
Zero Drift (24 hours)	< 0.25 ppm
Span Drift (24 hours)	< 0.5% of reading
Linearity	1% of full scale
Precision	0.5% reading
Lag Time	10 sec
Rise/Fall Time	<60 sec to 95%
Sample Flow Rate	800 cm^3/min . \pm 10%
Temperature Range	5 - 40°C operating
Humidity Range	0-95% RH, Non-Condensing
Temp Coefficient	< 0.05 % of reading per °C
Voltage Coefficient	< 0.05 % of reading per V
Dimensions (HxWxD)	7" x 17" x 23.5" (178 mm x 432 mm x 597 mm)
Weight	40 lb (18.1 kg)
AC Power	100 – 120V 50/60 Hz, 220 – 240 V 50/60 Hz
Environmental Conditions	Installation Category (Over voltage Category) II Pollution Degree 2
Standard I/O	1 Ethernet: 10/100Base-T 2 RS-232 (300 – 115,200 baud) 2 USB device ports 8 opto-isolated digital status outputs 6 opto-isolated digital control inputs 4 analog outputs
Optional I/O	1 USB com port 1 RS485 8 analog inputs (0-10V, 12-bit) 4 digital alarm outputs Multidrop RS232 3 4-20mA current outputs





PARAMETER	SPECIFICATION
Analog Output Resolution	1 part in 4096 of selected full-scale voltage
Certifications	CE: IEC 61010-1:2001, EN61326 - Class A North American: cNEMKO (Canada): CAN/CSA-C22.2 No. 61010-1-04 NEMKO-CCL (US):UL No.61010-1 (2 nd Edition)

3. GETTING STARTED

3.1. Unpacking and Initial Set Up

	CAUTION To avoid personal injury, always use two persons to lift and carry the Model GFC 7000T.
---	---

	WARNING Never disconnect PCAs, wiring harnesses or electronic subassemblies while the instrument is under power.
---	--

	CAUTION – Avoid Warranty Invalidation Printed circuit assemblies (PCAs) are sensitive to electro-static discharges too small to be felt by the human nervous system. Damage resulting from failure to use ESD protection when working with electronic assemblies will void the instrument warranty. See <i>A Primer on Electro-Static Discharge</i> in this manual for more information on preventing ESD damage.
---	--

NOTE It is recommended that you store shipping containers/materials for future use if/when the instrument should be returned to the factory for repair and/or calibration service. See Warranty section in this manual on page ii. Contact TAI at: http://www.teledyne-ai.com for obtaining a Return Authorization.
--

1. Verify that there is no apparent external shipping damage. If damage has occurred, please advise the shipper first, then Teledyne Instruments.
2. Included with your analyzer is a printed record of the final performance characterization performed on your instrument at the factory. This record, titled *Final Test and Validation Data Sheet* (P/N 04596) is an important quality assurance and calibration record for this instrument. It should be placed in the quality records file for this instrument.
3. Carefully remove the top cover of the analyzer and check for internal shipping damage.
 - Remove the set-screw located in the top, center of the Front panel.
 - Remove the 2 screws fastening the top cover to the unit (one per side towards the rear).
 - Slide the cover backwards until it clears the analyzer's front bezel.
Lift the cover straight up.
4. Inspect the interior of the instrument to make sure all circuit boards and other components are in good shape and properly seated.
5. Check the connectors of the various internal wiring harnesses and pneumatic hoses to make sure they are firmly and properly seated.

6. Verify that all of the optional hardware ordered with the unit has been installed. These are listed on the paperwork accompanying the analyzer.

VENTILATION CLEARANCE: Whether the analyzer is set up on a bench or installed into an instrument rack, be sure to leave sufficient ventilation clearance.

AREA	MINIMUM REQUIRED CLEARANCE
Back of the instrument	4 in.
Sides of the instrument	1 in.
Above and below the instrument	1 in.

Various rack mount kits are available for this analyzer. See Section 5.1 of this manual for more information.

3.2. Front Panel

Figure 3-1 shows the analyzer's front panel layout, followed by a close-up of the display screen in Figure 3-2, which is described in Table 3-1. The two USB ports on the front panel are provided for the connection of peripheral devices:

- Plug-in mouse (not included) to be used as an alternative to the touchscreen interface
- Thumb drive (not included) to download updates to instruction software (contact TAI Customer Service for information).

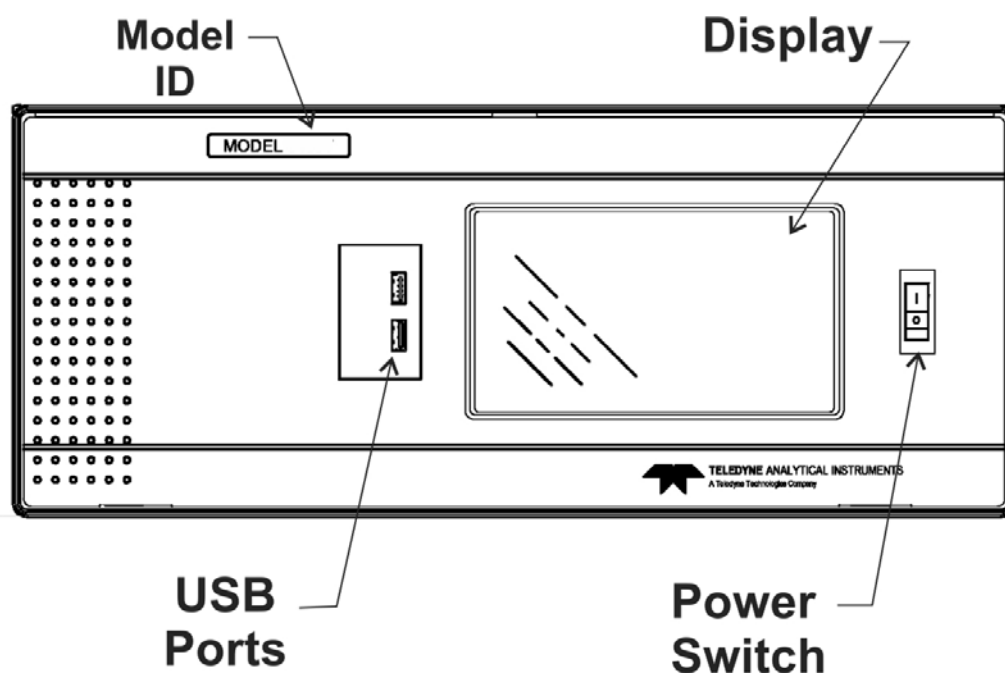

Figure 3-1: Front Panel Layout

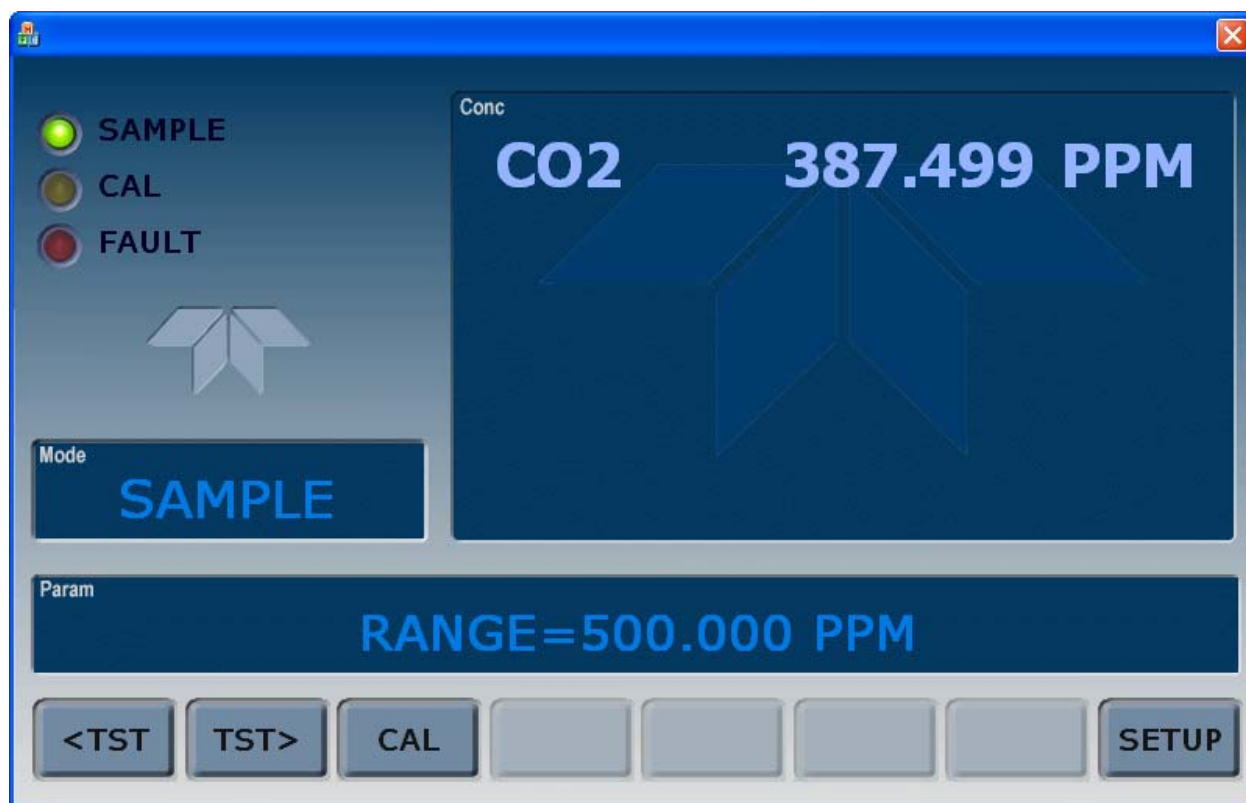

Figure 3-2: Display Screen and Touch Control



CAUTION – Avoid Damaging Touchscreen

Do not use hard-surfaced instruments such as pens to operate the touchscreen.

The front panel liquid crystal display includes touch control. Upon analyzer start-up, the display shows a splash screen and other initialization indicators before the main display appears, similar to Figure 3-2 above (may or may not display a Fault alarm). The LEDs on the display screen indicate the Sample, Calibration and Fault states; also on the screen is the gas concentration field (Conc), which displays real-time readouts for the primary gas and for the secondary gas if installed. The display screen also shows which mode the analyzer is currently in (Mode field), as well as messages and data (Param field). Along the bottom of the screen is a row of touch control buttons; only those that are currently applicable will have a label. Table 3-1 provides detailed information for each component of the screen.

Table 3-1: Display and Touchscreen Control Description

Field	Description/Function			
Status	LEDs indicating the states of Sample, Calibration and Fault, as follows:			
	Name	Color	State	Definition
	SAMPLE	Green	Off	Unit is not operating in sample mode, DAS is disabled.
			On	Sample Mode active; Front Panel Display being updated; DAS data being stored.
			Blinking	Unit is operating in sample mode, front panel display being updated, DAS hold-off mode is ON, DAS disabled
CAL	Yellow	Off	Auto Cal disabled	
		On	Auto Cal enabled	
		Blinking	Unit is in calibration mode	
FAULT	Red	Off	No warnings exist	
		Blinking	Warnings exist	
Conc	Displays the actual concentration of the sample gas currently being measured by the analyzer in the currently selected units of measure			
Mode	Displays the name of the analyzer's current operating mode			
Param	Displays a variety of informational messages such as warning messages, operational data, test function values and response messages during interactive tasks.			
Control Buttons	Displays dynamic, context sensitive labels on each button, which is blank when inactive until applicable.			

Figure 3-3 shows how the front panel display is mapped to the menu charts illustrated in this manual. The Mode, Param (parameters), and Conc (gas concentration) fields in the display screen are represented across the top row of each menu chart. The eight touchscreen control buttons along the bottom of the display screen are represented in the bottom row of each menu chart.

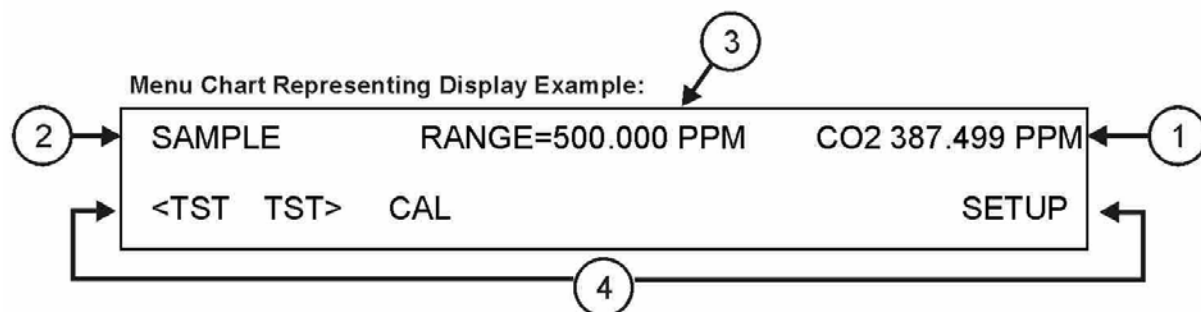
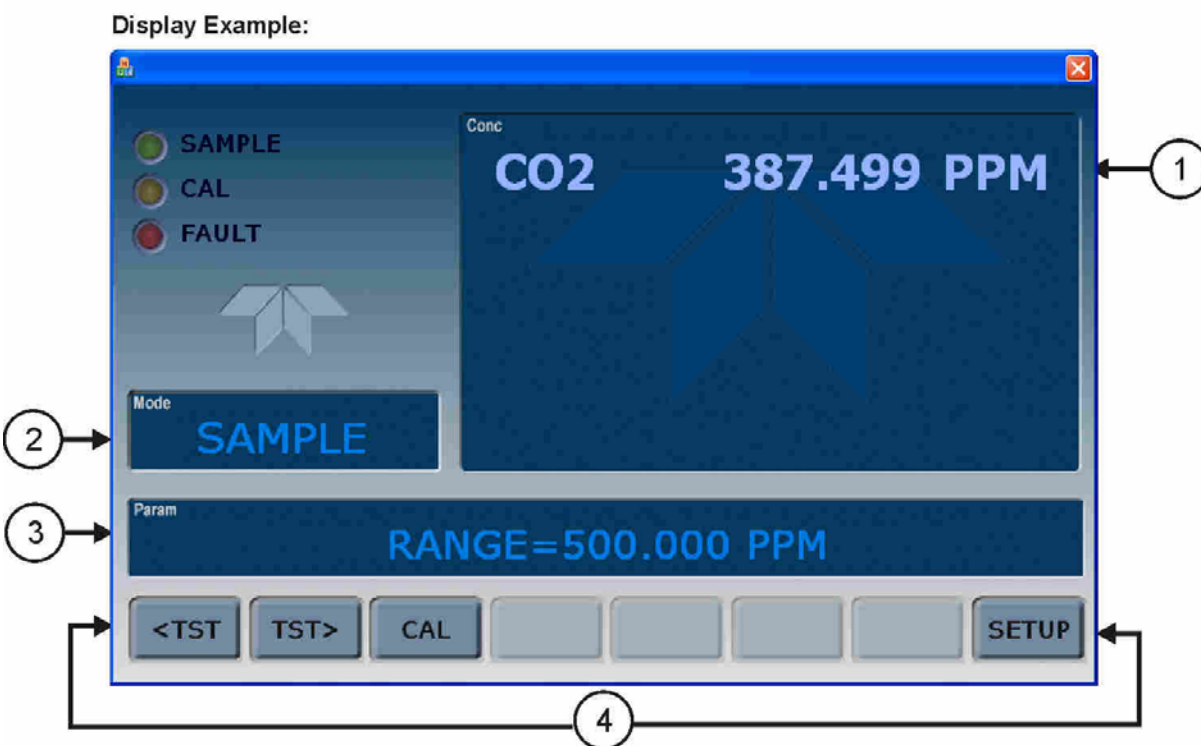
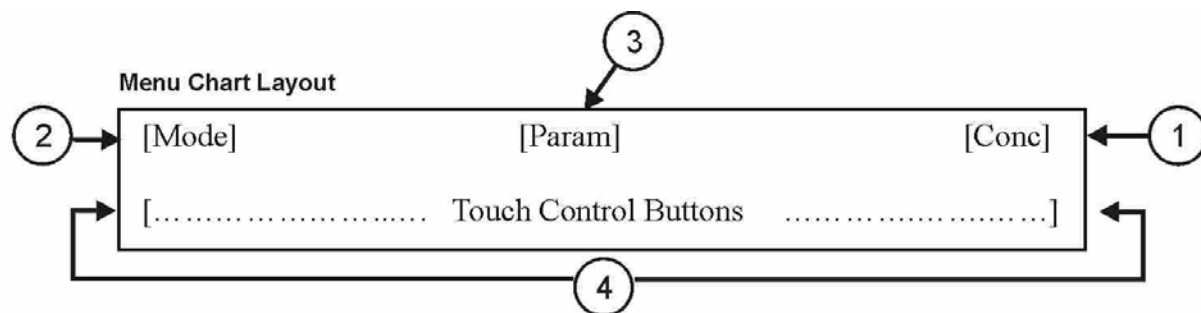

Figure 3-3: Display/Touch Control Screen Mapped to Menu Charts

3.3. Rear Panel

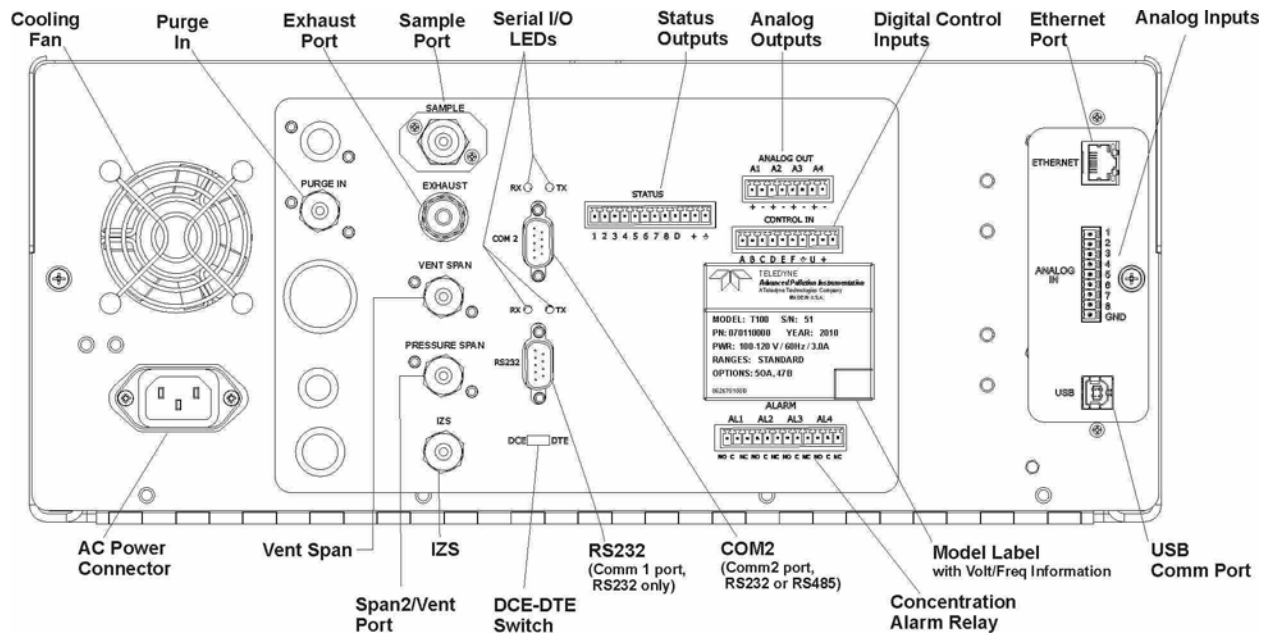



Figure 3-4: Rear Panel Layout

Table 3-2 provides a description of each component on the rear panel.

Table 3-2: Rear Panel Description

Component	Function
cooling fan	Pulls ambient air into chassis through side vents and exhausts through rear
 AC power connector	Connector for three-prong cord to apply AC power to the analyzer CAUTION! The cord's power specifications (specs) MUST comply with the power specs on the analyzer's rear panel Model number label
Model/specs label	Identifies the analyzer model number and provides power specs
PURGE IN	
PURGE OUT	(Applicable only for Model GFC 7000TU)
SAMPLE	Connect a gas line from the source of sample gas here Calibration gases are also inlet here on units without zero/span valve options installed
EXHAUST	Connect an exhaust gas line of not more than 10 meters long here that leads outside the shelter or immediate area surrounding the instrument
VENT SPAN	Span gas vent outlet for units with zero/span valve options installed Connect an exhaust gas line of not more than 10 meters long here
PRESSURE SPAN	On units with zero/span valve options installed, connect a gas line to the source of calibrated span gas here
IZS	Internal Zero Air: On units with zero/span valve options installed but no internal zero air scrubber attach a gas line to the source of zero air here
RX TX	LEDs indicate receive (RX) and transmit (TX) activity on the when blinking
COM 2	Serial communications port for RS-232 or RS-485
RS-232	Serial communications port for RS-232 only
DCE DTE	Switch to select either data terminal equipment or data communication equipment during RS-232 communication
STATUS	For outputs to devices such as Programmable Logic Controllers (PLCs)
ANALOG OUT	For voltage or current loop outputs to a strip chart recorder and/or a data logger
CONTROL IN	For remotely activating the zero and span calibration modes
ALARM	Option for concentration alarms and system warnings
ETHERNET	Connector for network or Internet remote communication, using Ethernet cable
ANALOG IN	Option for external voltage signals from other instrumentation and for logging these signals
USB	Com port optional connector for direct connection to laptop computer, using USB cable
Information Label	Includes voltage and frequency specifications

3.4. Internal Layout

Figure 3-5 shows a top-down view of the analyzer. The shown configuration includes the Ethernet board, IZS option, zero-air scrubber and an additional sample dryer. See Section 5 for optional equipment.

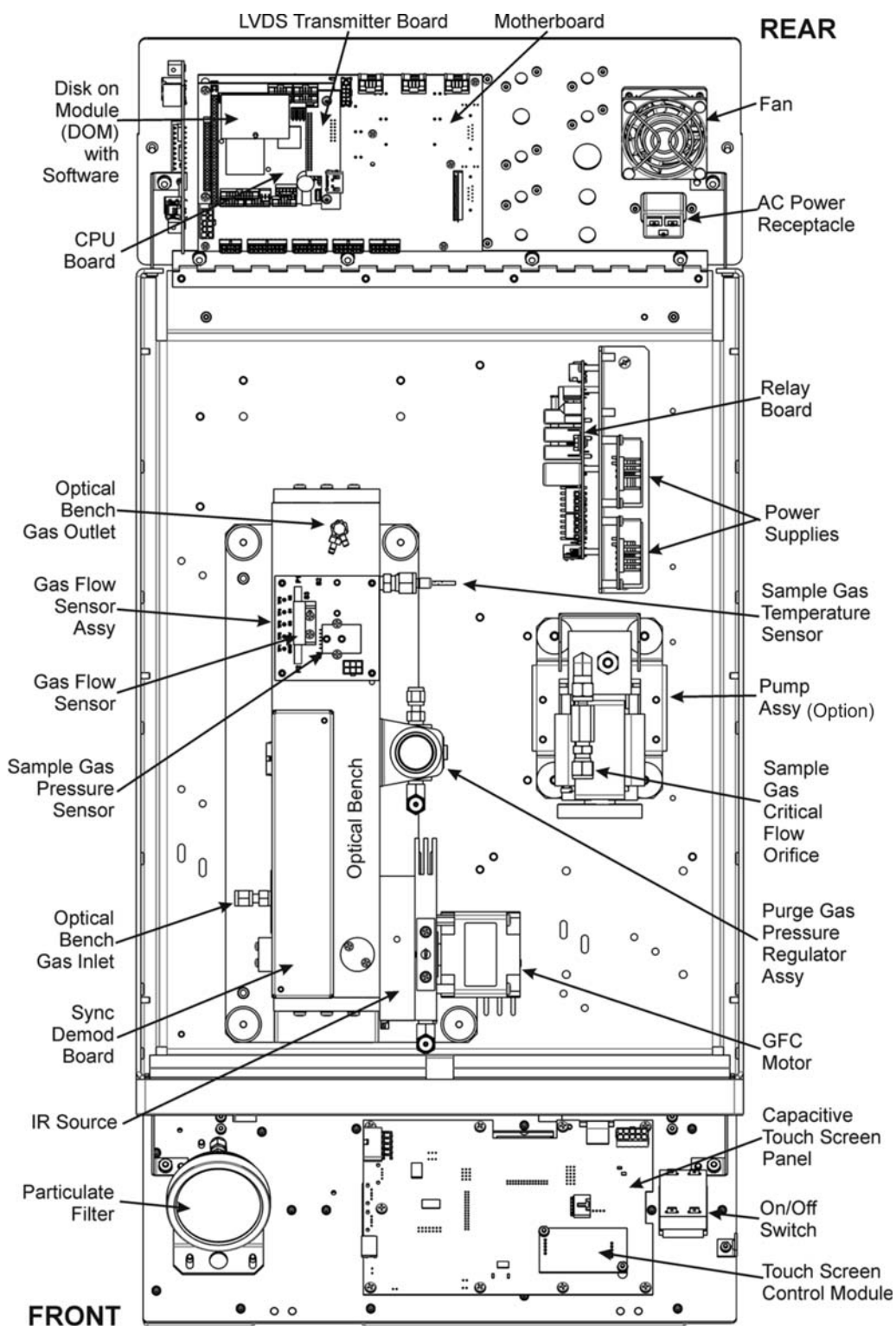

Figure 3-5: Internal Chassis Layout

Note: Models such as GFC 7000T used in pressurized sample applications do not have an internal pump assembly.

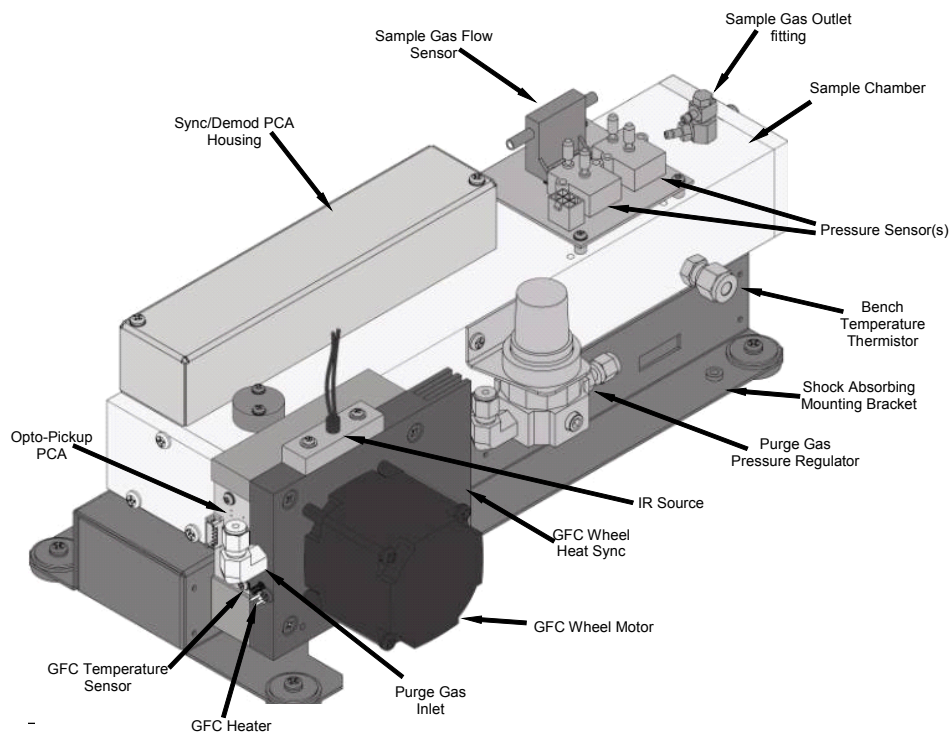



Figure 3-6: Optical Bench Layout

3.5. Electrical Connections

	<p>WARNING</p> <p>Never disconnect PCAs, wiring harnesses or electronic subassemblies while the instrument is under power.</p>
---	---

<p>NOTE</p> <p>To maintain compliance with EMC standards, it is required that the cable length be no greater than 3 meters for all I/O connections, which include Analog In, Analog Out, Status Out, Control In, Ethernet/LAN, USB, RS-232, and RS-485.</p>
--

Refer to Figure 3-4 for the locations of the rear panel connections.

3.5.1. Power Connection

	<p>WARNING</p> <p>Power connection must have functioning ground connection.</p> <p>Do not defeat the ground wire on power plug.</p> <p>Turn off analyzer power before disconnecting or connecting electrical subassemblies.</p> <p>Do not operate with cover off.</p>
---	--

	<p>CAUTION</p> <p>Check the voltage and frequency specifications on the rear panel Model Label for compatibility with the local power before plugging the analyzer into line power.</p> <p>Do not plug in the power cord if the voltage or frequency is incorrect.</p>
---	---

The GFC 7000T analyzer can be configured for both 100-130 V and 210-240 V at either 50 or 60 Hz. To avoid damage to your analyzer, make sure that the AC power voltage matches the voltage indicated on the rear panel serial number label and that the frequency is between 47 and 63 Hz.

Attach the power cord to the analyzer and plug it into a power outlet capable of carrying at least 10 A current at your AC voltage and that it is equipped with a functioning earth ground.

3.5.2. Connecting Analog Inputs (Option 64)

The Analog In connector is used for connecting external voltage signals from other instrumentation (such as meteorological instruments) and for logging these signals in the analyzer's internal DAS. The input voltage range for each analog input is 0-10 VDC.

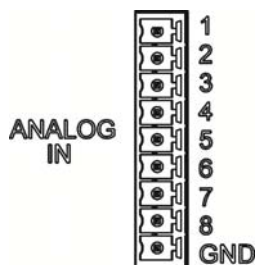

Figure 3-7: Analog Input Connector

Pin assignments for the Analog In connector are presented in Table 3-3.

Table 3-3: Analog Input Pin Assignments

PIN	DESCRIPTION	DAS PARAMETER ¹
1	Analog input # 1	AIN 1
2	Analog input # 2	AIN 2
3	Analog input # 3	AIN 3
4	Analog input # 4	AIN 4
5	Analog input # 5	AIN 5
6	Analog input # 6	AIN 6
7	Analog input # 7	AIN 7
8	Analog input # 8	AIN 8
GND	Analog input Ground	N/A

¹ See Section 6.7 for details on setting up the DAS.

3.5.3. Connecting Analog Outputs

The GFC 7000T is equipped with several analog output channels accessible through a connector on the back panel of the instrument. The standard configuration for these outputs is mVDC. An optional current loop output is available for each.

When the instrument is in its default configuration, channels A1 and A2 output a signal that is proportional to the CO₂ concentration of the sample gas. Either can be used for connecting the analog output signal to a chart recorder or for interfacing with a data logger.

Output A3 is only used if the optional O₂ sensor is installed.

Channel A4 is special. It can be set by the user (see Section 6.13.9) to output any one of the parameters accessible through the <TST TST> keys of the units sample display.

To access these signals attach a strip chart recorder and/or data-logger to the appropriate analog output connections on the rear panel of the analyzer.

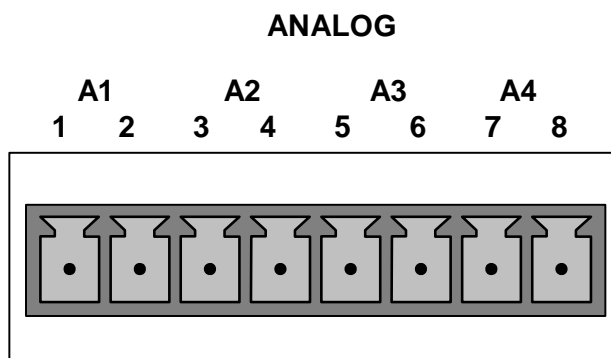

Pin-outs for the analog output connector at the rear panel of the instrument are:

Table 3-4: GFC 7000T Analog Output Pin Outs

PIN	ANALOG OUTPUT	VDC SIGNAL	MADC SIGNAL
1	A1	V Out	I Out +
2		Ground	I Out -
3	A2	V Out	I Out +
4		Ground	I Out -
5	A3 (Only used if O ₂ sensor is installed)	V Out	I Out +
6		Ground	I Out -
7	A4	V Out	Not used
8		Ground	Not used

- The default analog output voltage setting of the GFC 7000T CO₂ Analyzer is 0 – 5 VDC with a range of 0 – 500 ppm.
- To change these settings, see Sections 6.13.4 and 6.8 respectively.

3.5.4. Connecting the Status Outputs

If you wish utilize the analyzer's status outputs to interface with a device that accepts logic-level digital inputs, such as programmable logic controllers (PLC's) they are accessed via a 12-pin connector on the analyzer's rear panel labeled STATUS.

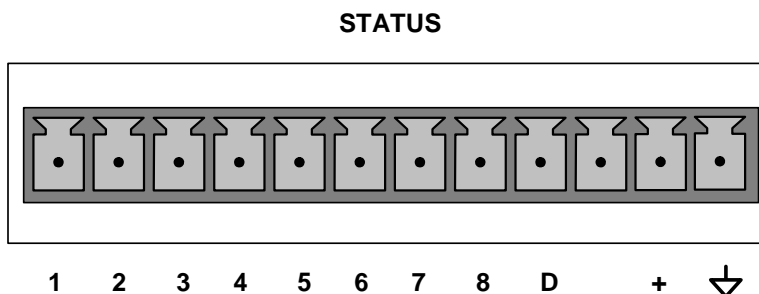

Figure 3-8: Status Connector

NOTE

Most PLC's have internal provisions for limiting the current the input will draw. When connecting to a unit that does not have this feature, external resistors must be used to limit the current through the individual transistor outputs to $\leq 50\text{mA}$ ($120\ \Omega$ for 5V supply).

The pin assignments for the status outputs can be found in the table below:

Table 3-5: Status Output Pin-outs

OUTPUT #	STATUS DEFINITION	CONDITION
1	SYSTEM OK	On if no faults are present.
2	CONC VALID	On if CO ₂ concentration measurement is valid. If the CO ₂ concentration measurement is invalid, this bit is OFF.
3	HIGH RANGE	On if unit is in high range of DUAL or AUTO range modes.
4	ZERO CAL	On whenever the instruments ZERO point is being calibrated.
5	SPAN CAL	On whenever the instruments SPAN point is being calibrated.
6	DIAG MODE	On whenever the instrument is in DIAGNOSTIC mode.
7	ALARM1	On whenever the measured CO ₂ concentration is above the set point for ALM1
8	ALARM2	On whenever the measured CO ₂ concentration is above the set point for ALM2
D	EMITTER BUS	The emitters of the transistors on pins 1-8 are bused together.
+	DC POWER	+ 5 VDC
⚡	Digital Ground	The ground level from the analyzer's internal DC power supplies.

3.5.5. Connecting the Control Inputs

If you wish to use the analyzer to remotely activate the zero and span calibration modes, several digital control inputs are provided through a 10-pin connector labeled CONTROL IN on the analyzer's rear panel.

There are two methods for energizing the control inputs. The internal +5V available from the pin labeled "+" is the most convenient method. However, if full isolation is required, an external 5 VDC power supply should be used.

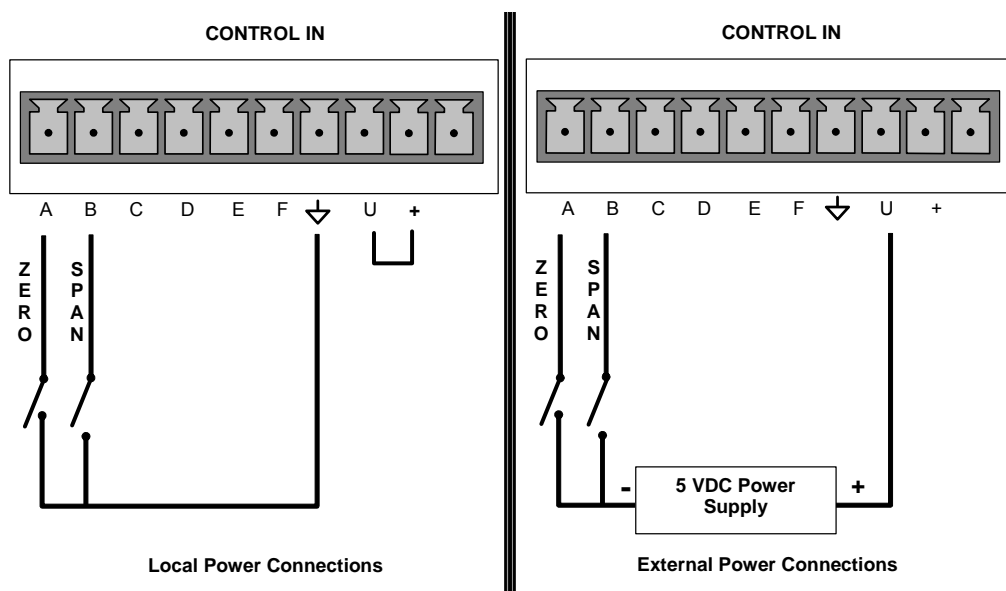

The pin assignments for the digital control inputs can be found in the table below:

Table 3-6: Control Input Pin-outs

INPUT #	STATUS DEFINITION	ON CONDITION
A	REMOTE ZERO CAL	The Analyzer is placed in Zero Calibration mode. The mode field of the display will read ZERO CAL R.
B	REMOTE SPAN CAL	The Analyzer is placed in Span Calibration mode. The mode field of the display will read SPAN CAL R.
C	SPARE	Used in Air Products Configuration only. Input 'C' is used to select the range for remote calibration. When input C is low, the instrument selects high range during contact closure calibration.
D	SPARE	
E	SPARE	
F	SPARE	
⏚	Digital Ground	May be connected to the ground of the data logger/recorder.
U	Pull-up supply for inputs	Input pin for +5 VDC required to activate pins A – F. This can be from an external source or from the "+" pin of the instruments STATUS connector.
+	Internal +5V Supply	Internal source of +5V which can be used to actuate control inputs when connected to the U pin.

3.5.6. Connecting the Communications Interfaces

For RS-232 or RS-485 communications through the analyzer's serial interface com ports, refer to Section 6.11 of this manual for instructions on their configuration and usage.

3.5.6.1. Connecting to a LAN or the Internet

For network or Internet communication with the analyzer, connect an Ethernet cable from the analyzer's rear panel Ethernet interface connector to an Ethernet access port.

NOTE:

The GFC 7000T firmware supports dynamic IP addressing or DHCP.

If your network also supports DHCP, the analyzer will automatically configure its LAN connection appropriately,

If your network does not support DHCP, see Section 6.11.6.3 for instructions on manually configuring the LAN connection.

3.5.6.2. Connecting to a Personal Computer (PC)

If the analyzer is configured with the USB com option, connect a USB cable between the USB ports of the analyzer's rear panel and a desktop or laptop PC for direct communication between the two. Their baud rates must match (see Section 6.11.8).

3.5.6.3. Connecting to a Multidrop Network

If your unit has a Teledyne Instruments RS-232 multidrop card (Option 62), see Section 6.11.7 for instructions on setting it up.

3.5.7. Alarms

3.5.7.1. Relay Alarm Outputs — Standard Configuration

There are 4 relay alarm outputs (AL1-AL4) on the rear panel.

- AL1 is for system okay,
- AL2 is for concentration limit 1 exceeded and
- AL3 is for concentration limit 2 exceeded.
- AL4 is not used

The relay alarm output AL1 is enabled all the time, whereas the AL2 and AL3 can be enabled/disabled by going into the diagnostics menu (with 929 password), then factory options, then turning conc. Alarm Relays ON or OFF.

When the concentration alarm relays are enabled, concentration alarms status is no longer available through the "Status output" pins. So, either the alarm relays or the status bits could be used to monitor the

concentration alarms but not both at the same time. The default factory setting is to enable the concentration alarm relays.

The AL1 relay is energized when the system is okay and de-energized when the system has a fault. The AL2 and AL3 relays energize when the corresponding concentration limits are exceeded.

3.5.7.2. Relay Alarm Outputs — Air Products Configuration

In the Air Products configuration, the 4 relay alarm outputs (AL1-AL4) on the rear panel are configured differently..

- AL1 is for “system okay”,
- AL2 is for “high range status”
- AL3 is for “zero calibration status”
- AL4 is not used

The AL1 relay is energized when the system is okay and de-energized when the system has a fault. The AL2 relay is energized when the high auto-range is in use and and AL3 relays energize when the the instrument is in zero calibration mode.

Also, in the Air Products configuration, an additional control input is available on this instrument. Control input “C” is used to select the range for remote calibration. When input C is low, the instrument selects high range during contact closure calibration. See Section 6.15.12.

3.6. Pneumatic Connections



CAUTION!

Do not operate this instrument until you've removed dust plugs from SAMPLE and EXHAUST ports on the rear panel!

3.6.1. Basic Pneumatic Connections

NOTE

In order to prevent dust from getting into the gas flow channels of your analyzer, it was shipped with small plugs inserted into each of the pneumatic fittings on the back panel. Remove these plugs before operating the analyzer. It is recommended that they be stored for future use (moving, storing or shipping the analyzer).

Pneumatic connections are made to the rear panel at the labeled tube fittings and are described in Table 3-7.

NOTE

Sample and calibration gases should only come into contact with PTFE (Teflon), FEP, glass, stainless steel or brass.

Table 3-7: Rear Panel Pneumatic Connections

Rear Panel Label	Function
SAMPLE	Connect a gas line from the source of sample gas here. Calibration gasses are also inlet here on units without zero/span valve option installed.
EXHAUST	Connect an exhaust gas line of not more than 10 meters long here.
PRESSURE SPAN	On units with zero/span valve option installed, connect a gas line to the source of calibrated span gas here.
VENT SPAN	Not used
ZERO	On units with zero/span valve option installed, attach a gas line to the source of zero air here.
TO PURGE	This inlet supplies purge air to the GFC wheel housing Connect a source of dried air that has been scrubbed of CO ₂ .
FROM PURGE	This exhausts purge air to the GFC wheel housing. Connect an exhaust gas line of not more than 10 meters long here. It is only used on the GFC 7000TU instrument.

1. Attach a sample inlet line to the sample inlet port. The SAMPLE input line should not be more than 2 meters long.
2. Attach sources of zero air and span gas
3. Span Gas is a gas specifically mixed to match the chemical composition of the type of gas being measured at near full scale of the desired measurement range.

When CO₂ measurements are to be made with the Teledyne Instruments Model GFC 7000T Analyzer it is recommended that you use a gas calibrated to have a CO₂ content equaling 80% of the range of compositions being measured.

EXAMPLE: If the application is to measure between 0 ppm and 50 ppm, an appropriate Span Gas would be 40 ppm. If the application is to measure between 0 ppm and 100 ppm, an appropriate Span Gas would be 80 ppm.

Zero Air is similar in chemical composition to the earth's atmosphere but scrubbed of all components that might affect the analyzer's readings. In the case of CO₂ measurements this means CO₂ less than 0.1 ppm of CO₂ and Water Vapor.

Zero Air can be purchased in pressurized canisters or created using a Teledyne Instruments Model 701 Zero Air Generator in combination with a canister of indicating soda-lime.

4. Attach an exhaust line to the exhaust outlet port.

The exhaust from the analyzer and vent lines should be vented to atmospheric pressure using maximum of 10 meters of 1/4" PTFE tubing.

5. Attach a source of dried air scrubbed of CO₂ to the purge inlet port

The source of purge gas should be at least 10 psig and capable of maintaining a flow of at least 1 liter/min.

Purge source gas pressure should not exceed 30 psig. The purge exhaust is only used on the GFC 7000TU model.

6. Once the appropriate pneumatic connections have been made, check all pneumatic fittings for leaks.

**CAUTION**

Venting should be outside the shelter or immediate area surrounding the instrument.

NOTE

The minimum gas pressure of the source of purge air should be 7.5 psig.

If the source of the purge air is shared by a Teledyne Instruments T700 (as shown in figure 3-7) the minimum gas pressure should be 25 psig and should not exceed 35 psig.

3.6.1.1. Inlet Pressure Rating/Consideration

This instrument has no significant internal restriction or adjustable valve to control/adjust flow. Sample must be introduced to the inlet fitting at a fraction of a PSI above ambient pressure, just enough to drive the flow to the proper value range. Depending on the ultimate sample source pressure, a needle valve, restrictor, critical orifice or combination there should be deployed to achieve this. Do not directly apply significant pressure to the inlet of the unit under any circumstances, as damage / and or personal injury may result.

Figure 3-8 illustrates the internal gas flow through the Model GFC 7000T Analyzer in its basic configuration. See also the pneumatic diagrams in any Addendum located at the front of this manual if your application required modification to the sample system.

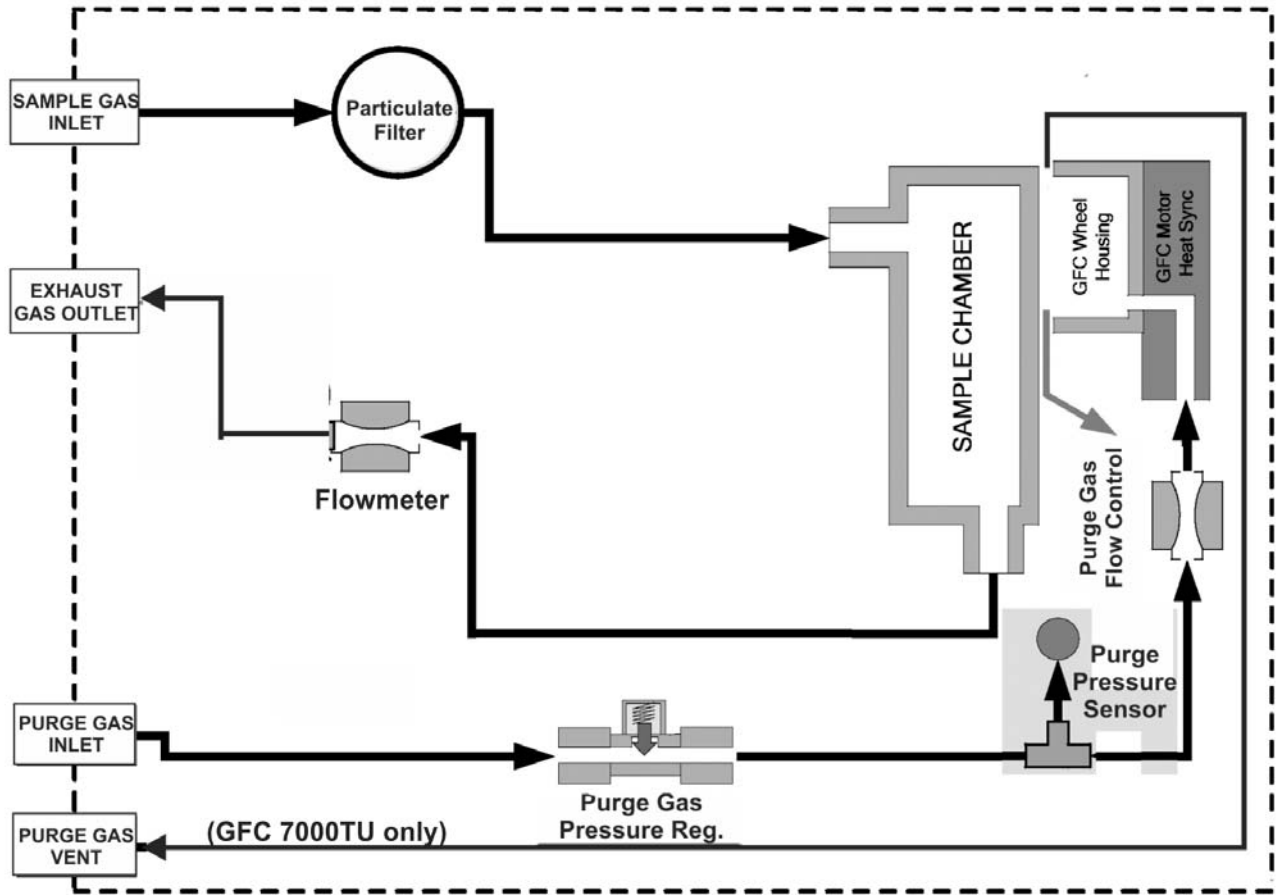

Figure 3-7: Internal Gas Flow–Basic Configuration

3.6.2. Connections with Internal Valve Options Installed

Figure 3-8 and Figure 3-9 show the pneumatic connections for the ambient zero and ambient span valve option (Option 50A). See also the Addendum in the front of this manual for pressurized sample applications with valve option.

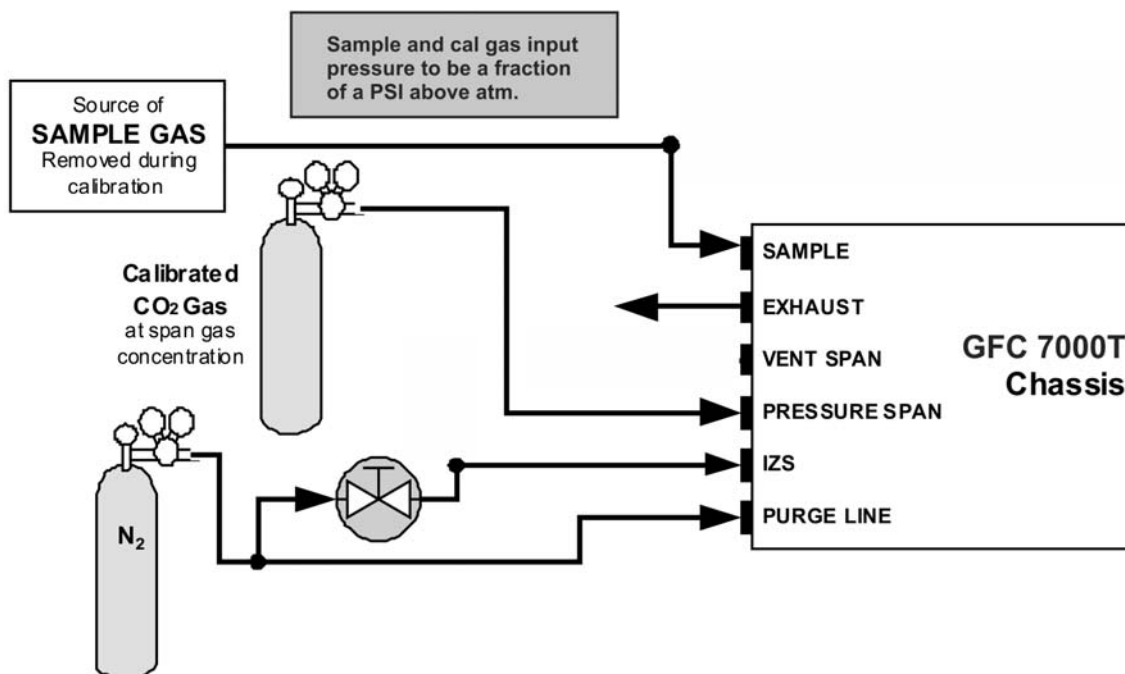

Figure 3-80: Pneumatic Connections with Zero/ Span Valves (OPT 50A)

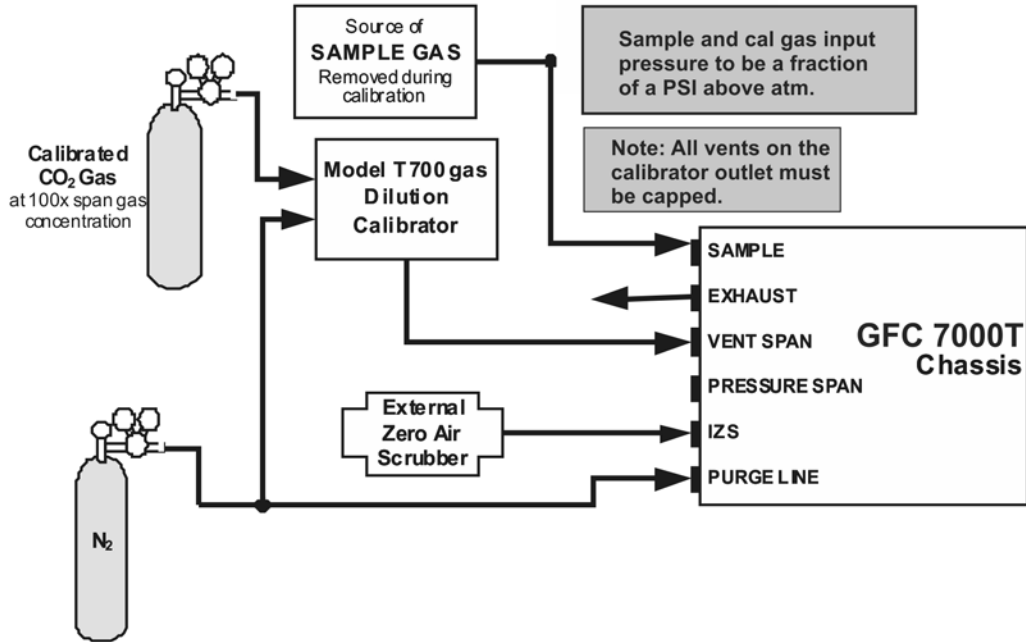

Figure 3-91: Pneumatic Connections with Zero/Span Valves (Opt 50A) and External Zero Air Scrubber

3.6.3. Pneumatic Connections in Multipoint Calibration Applications

Some applications may require multipoint calibration checks where span gas of several different concentrations is needed. We recommend using high-concentration, certified, calibration gas supplied to the analyzer through a Gas Dilution Calibrator such as a Teledyne Instruments Model T700. This type of calibrator precisely mixes Span Gas and Zero Air to produce any concentration level between 0 ppm and the concentration of the calibrated gas.

Figure 3-12 depicts the pneumatic set up in this sort of application of a Model GFC 7000T CO₂ Analyzer with ambient zero/ambient span valve option 50A installed (a common configuration for this type of application).

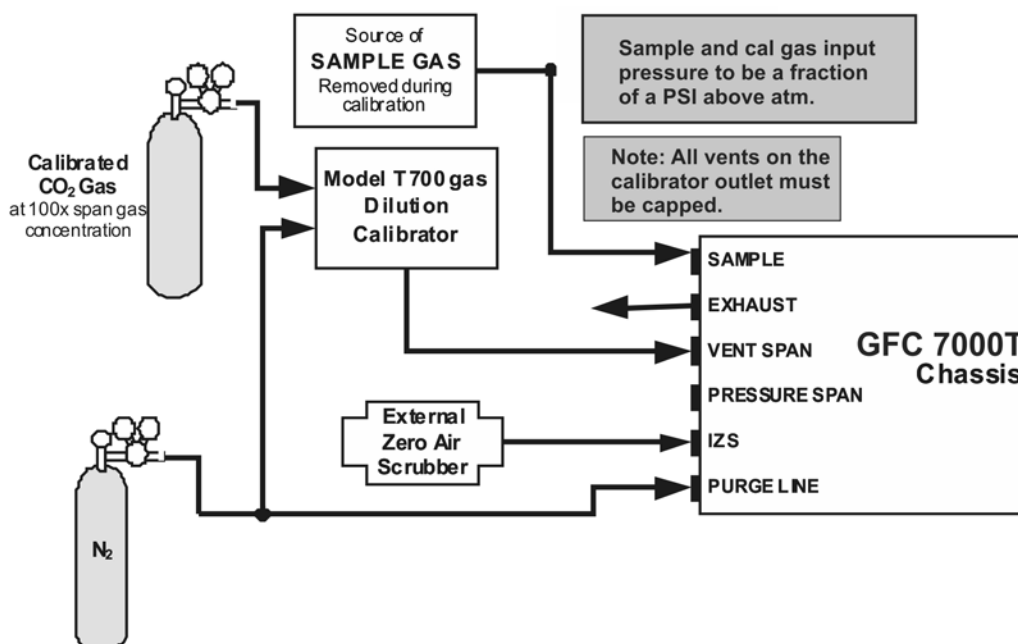

Figure 3-102: Example of Pneumatic Set up for Multipoint Calibration

3.6.4. Setting the Internal Purge Air Pressure

In order to maintain proper purge air flow through the GFC wheel housing, a manually adjustable pressure regulator is provided (see Figure 3-5). This regulator includes two output ports. One is used to supply purge air to the GFC wheel. The other may be used to attach a pressure gauge.

To adjust the internal purge air pressure of the GFC 7000T:

1. Turn off the instrument.
2. Remove the source of zero air attached to the purge line inlet port at the back of the analyzer.
3. Remove the analyzer's top cover.
4. Remove the cap from the second, unused, output port on the pressure regulator.
5. Attach a pressure gauge capable of measuring in the 5-10 psig range with 0.5 psig resolution to the port.

6. Turn the instrument on.
7. Make sure the zero air supply to the analyzer's purge line inlet is supplying gas at a stable pressure above 7.5 psig.
8. Adjust the GFC 7000T's pressure regulator until the attached gauge reads 7.5 psig.
9. Turn off the instrument.
10. Remove the source of zero air attached to the purge line inlet port at the back of the analyzer.
11. Remove the pressure gauge and reattach the end cap removed in step 4 above.
12. Replace the analyzer's top cover.

3.7. Initial Operation

If you are unfamiliar with the GFC 7000T theory of operation, we recommend that you read Section 10. For information on navigating the analyzer's software menus, see the menu trees described in Appendix A.

NOTE

The analyzer's cover must be installed to ensure that the temperatures of the GFC wheel and absorption cell assemblies are properly controlled.

3.7.1. Startup

After electrical and pneumatic connections are made, and initial functional check is required. Turn on the instrument. The pump, exhaust fan and PMT cooler fan should start immediately. The display will briefly show a logo splash screen at the start of initialization.

The analyzer should automatically switch to Sample Mode after completing the boot-up sequence and start monitoring CO₂ gas. However, there is an approximately one hour warm-up period before reliable gas measurements can be taken. During the warm-up period, the front panel display may show messages in the Parameters field.

3.7.2. Warm Up

During the warm-up period various portions of the instrument's front panel may behave as indicated in Table 3-8.

Table 3-8: Front Panel Display During System Warm-Up

NAME	COLOR	BEHAVIOR	SIGNIFICANCE
Conc field	N/A	Displays current, compensated CO ₂ Concentration	This is normal operation, but deemed inaccurate during the warm-up period.
Mode field	N/A	Displays current mode, e.g., "SAMPLE"	Instrument is in Sample mode but is still in the process of warming up. (DAS holdoff period is active)
Param field	N/A	Displays menu items and messages.	Refer to Table 3-9 for a list and descriptions of warning messages.
STATUS LEDs			
Sample	Green	On	Unit is operating in sample mode; front panel display is being updated. Flashes On/Off when adaptive filter is active
Cal	Yellow	Off	The instrument's calibration is not enabled.
Fault	Red	Blinking	The analyzer is warming up and hence out of specification for a fault-free reading. Various warning messages appear in the Param field.

3.7.3. Warning Messages

Because internal temperatures and other conditions may be outside specified limits during the analyzer's warm-up period, the software will suppress most warning conditions for 30 minutes after power up. If warning messages persist after the 30 minutes warm up period is over, investigate their cause using the troubleshooting guidelines in Section 11 of this manual.

To view and clear warning messages, press:

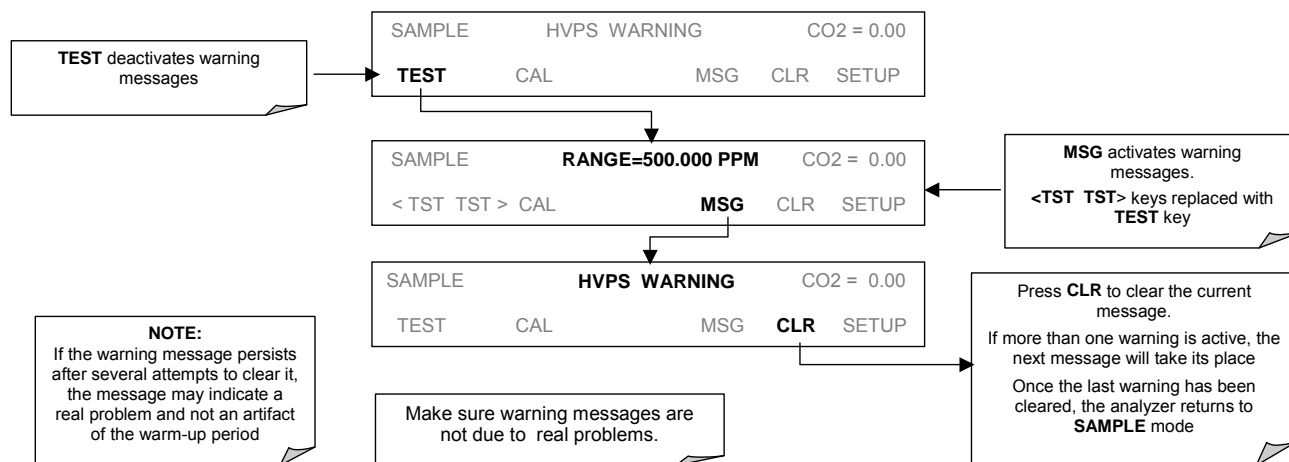

Table 3-6 lists brief descriptions of the warning messages that may occur during start up.

Table 3-9: Possible Warning Messages at Start-Up

MESSAGE	MEANING
ANALOG CAL WARNING	The instrument's A/D circuitry or one of its analog outputs is not calibrated.
BENCH TEMP WARNING	The optical bench Temperature is outside the specified limits.
BOX TEMP WARNING	Remote span calibration failed while the dynamic span feature was set to turned on.
CANNOT DYN SPAN	Remote zero calibration failed while the dynamic zero feature was set to turned on.
CANNOT DYN ZERO	Configuration was reset to factory defaults or was erased.
CONC ALRM1 WARNING	Concentration alarm 1 is enabled and the measured CO ₂ level is ≥ the set point.
CONC ALRM2 WARNING	Concentration alarm 2 is enabled and the measured CO ₂ level is ≥ the set point.
CONFIG INITIALIZED	Configuration storage was reset to factory configuration or erased.
DATA INITIALIZED	DAS data storage was erased.
O2 CELL TEMP WARN	O ₂ sensor cell temperature outside of warning limits.
PHOTO TEMP WARNING	The temperature of the IR photometer is outside the specified limits.
PURGE PRESS WARN	(GFC7000TU only) Purge pressure is outside of warning limits specified by the PURGE_PRESS_SET variable. Default limits are 2.5 to 12.5 PSIG
REAR BOARD NOT DET	The CPU is unable to communicate with the motherboard.
RELAY BOARD WARN	The firmware is unable to communicate with the relay board.
SAMPLE FLOW WARN	The flow rate of the sample gas is outside the specified limits.
SAMPLE PRESS WARN	Sample gas pressure outside of operational parameters.
SAMPLE TEMP WARN	The temperature of the sample gas is outside the specified limits.
SOURCE WARNING	The IR source may be faulty.
SYSTEM RESET	The computer was rebooted.
WHEEL TEMP WARNING	The Gas Filter Correlation wheel temperature is outside the specified limits.

3.7.4. Functional Check

1. After the analyzer's components has warmed up for at least 30 minutes, verify that the software properly supports any hardware options that were installed.
2. Check to make sure that the analyzer is functioning within allowable operating parameters. Appendix C includes a list of test functions viewable from the analyzer's front panel as well as their expected values. These functions are also useful tools for diagnosing performance problems with your analyzer (Section 11.1.2). The enclosed Final Test and Validation Data sheet (part number 04307) lists these values before the instrument left the factory.

To view the current values of these parameters press the following button sequence on the analyzer's front panel. Remember until the unit has completed its warm up these parameters may not have stabilized.

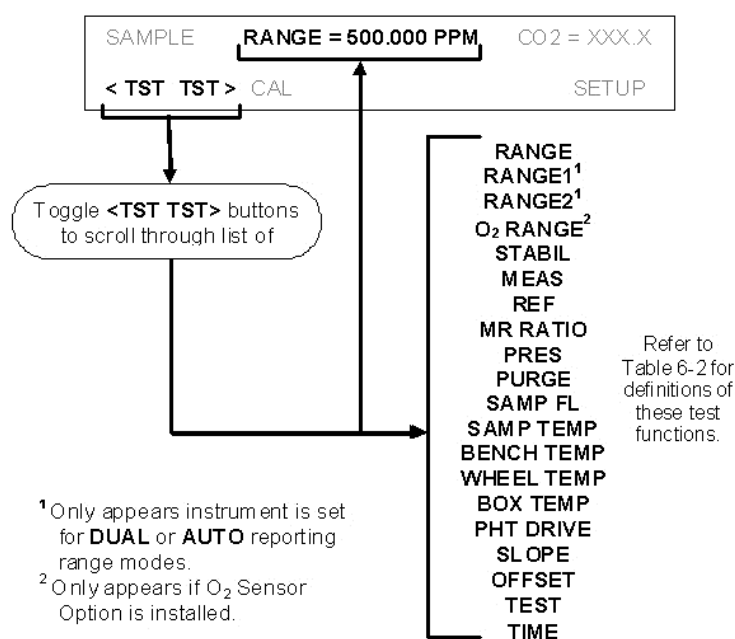

If your network is running a dynamic host configuration protocol (DHCP) software package, the Ethernet feature will automatically configure its interface with your LAN. (See Section 6.11.6.2). This configuration is useful for quickly getting an instrument up and running on a network. However, for permanent Ethernet connections, a static IP address should be used. (See Section 6.11.6.3).

3.8. Initial Calibration Procedure

The next task is to calibrate the analyzer.

To perform the following calibration you must have sources for zero air and span gas available for input into the sample port on the back of the analyzer. See Section 3.6.1 for instructions for connecting these gas sources.

While it is possible to perform this procedure with any range setting we recommend that you perform this initial checkout using the 500 ppm range.

	<p>NOTE</p> <p>The following procedure assumes that the instrument does not have any of the available Zero/Span Valve Options installed.</p> <p>See Section 7.4 for instructions for calibrating instruments possessing Z/S valve options.</p>
---	---

1. Set the Analog Output Range:

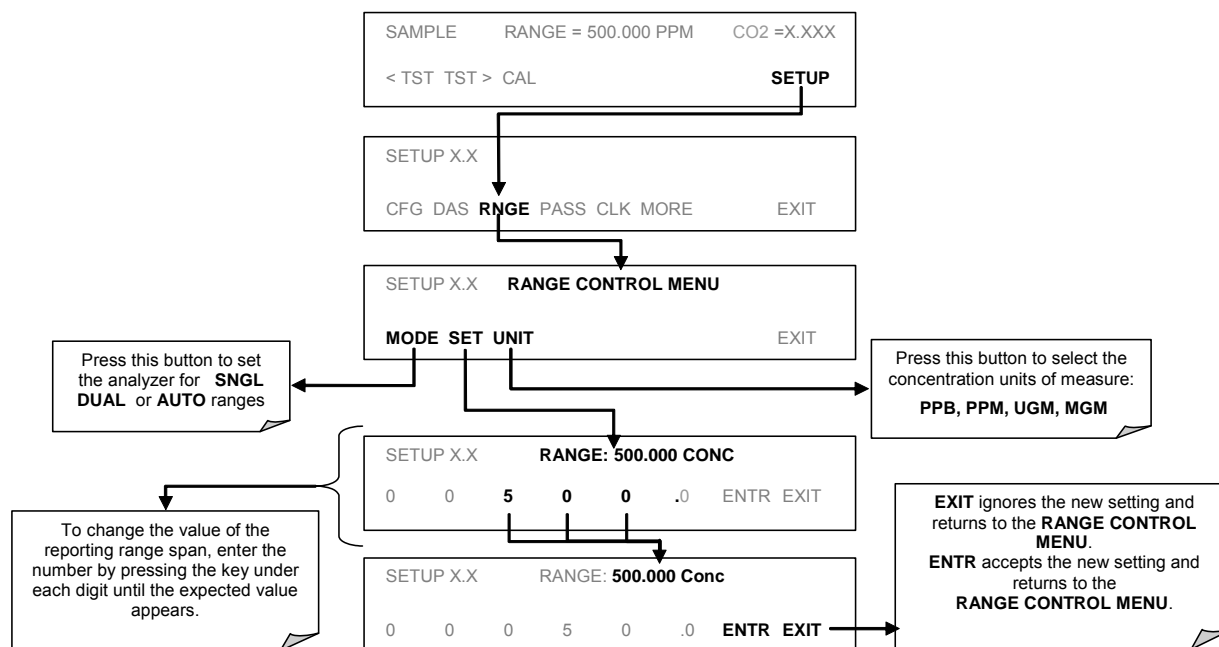

- Set the expected CO₂ span gas concentration

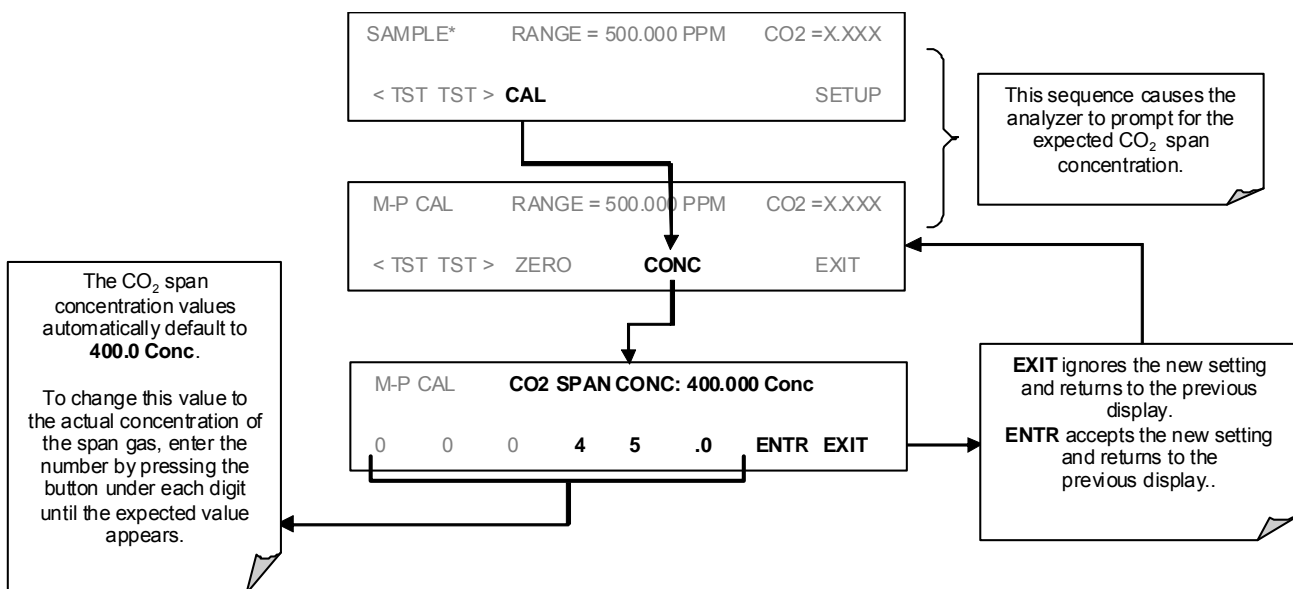

NOTE

For this Initial Calibration it is important to independently verify the precise CO₂ Concentration Value of the SPAN gas.

If the source of the Span Gas is from a Calibrated Bottle, use the exact concentration value printed on the bottle.

3. Perform the Zero/Span Calibration Procedure

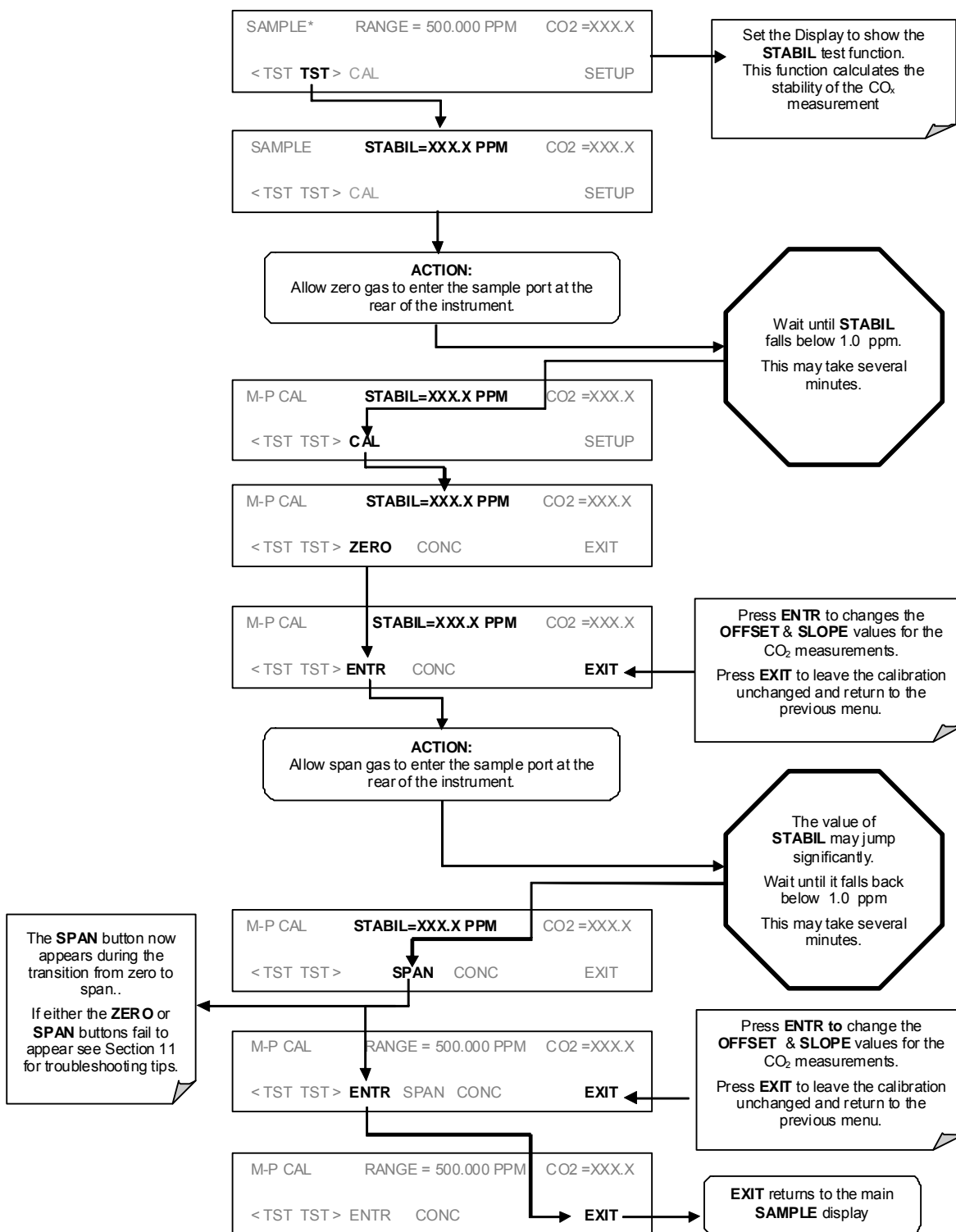

3.8.1. Initial O₂ Sensor Calibration Procedure

If your instrument has an O₂ sensor option installed that should be calibrated as well.

3.8.1.1. O₂ Calibration Setup

The pneumatic connections for calibrating are as follows:

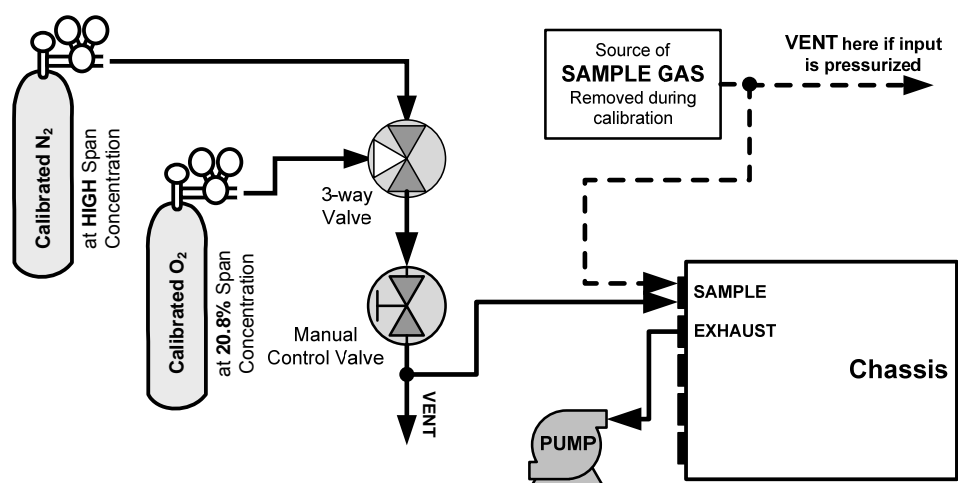

Figure 3-113: O₂ Sensor Calibration Set Up

O₂ SENSOR ZERO GAS: Teledyne Instruments' recommends using pure N₂ when calibration the zero point of your O₂ sensor option.

O₂ SENSOR SPAN GAS: Teledyne Instruments' recommends using 21% O₂ in N₂ when calibration the span point of your O₂ sensor option.

3.8.1.2. O₂ Calibration Method

STEP 1 – SET O₂ SPAN GAS CONCENTRATION:

Set the expected O₂ span gas concentration.

This should be equal to the percent concentration of the O₂ span gas of the selected reporting range (default factory setting = 20.8%; the approximate O₂ content of ambient air).

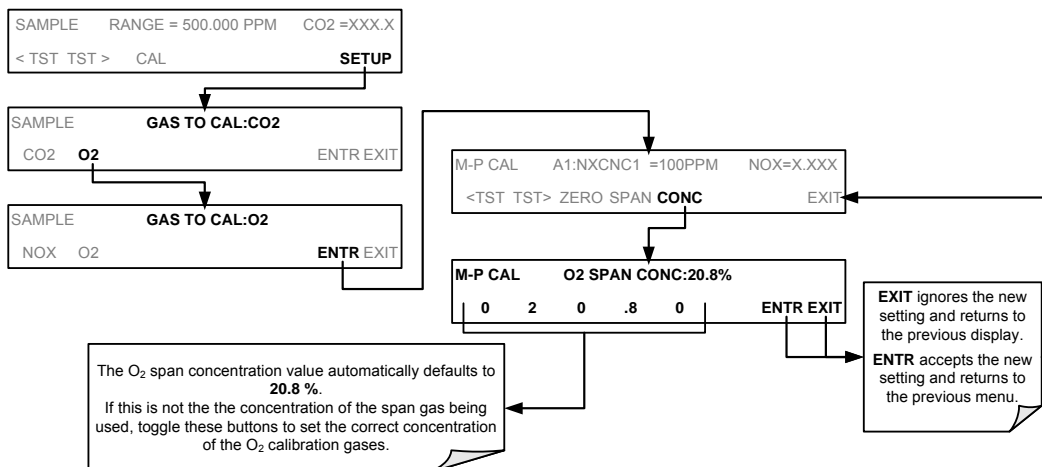

STEP 2 – ACTIVATE O₂ SENSOR STABILITY FUNCTION

To change the stability test function from NO_x concentration to the O₂ sensor output, press:

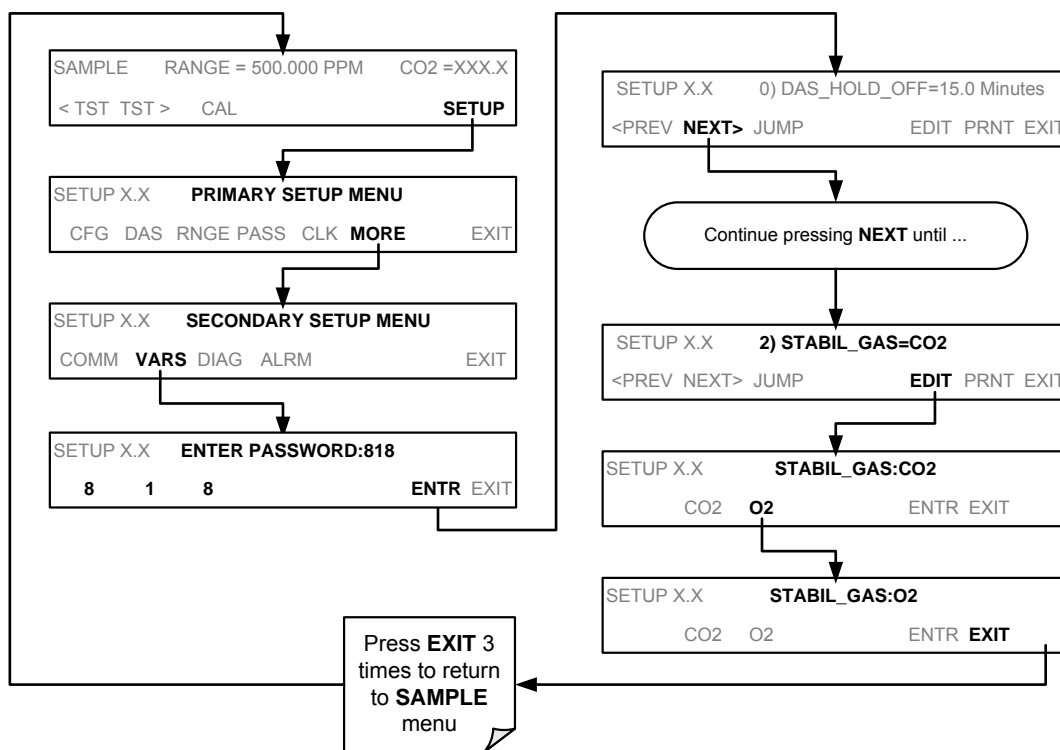

NOTE

Use the same procedure to reset the STB test function to CO₂ when the O₂ calibration procedure is complete.

STEP 3 – O₂ Zero/Span Calibration perform by pressing:

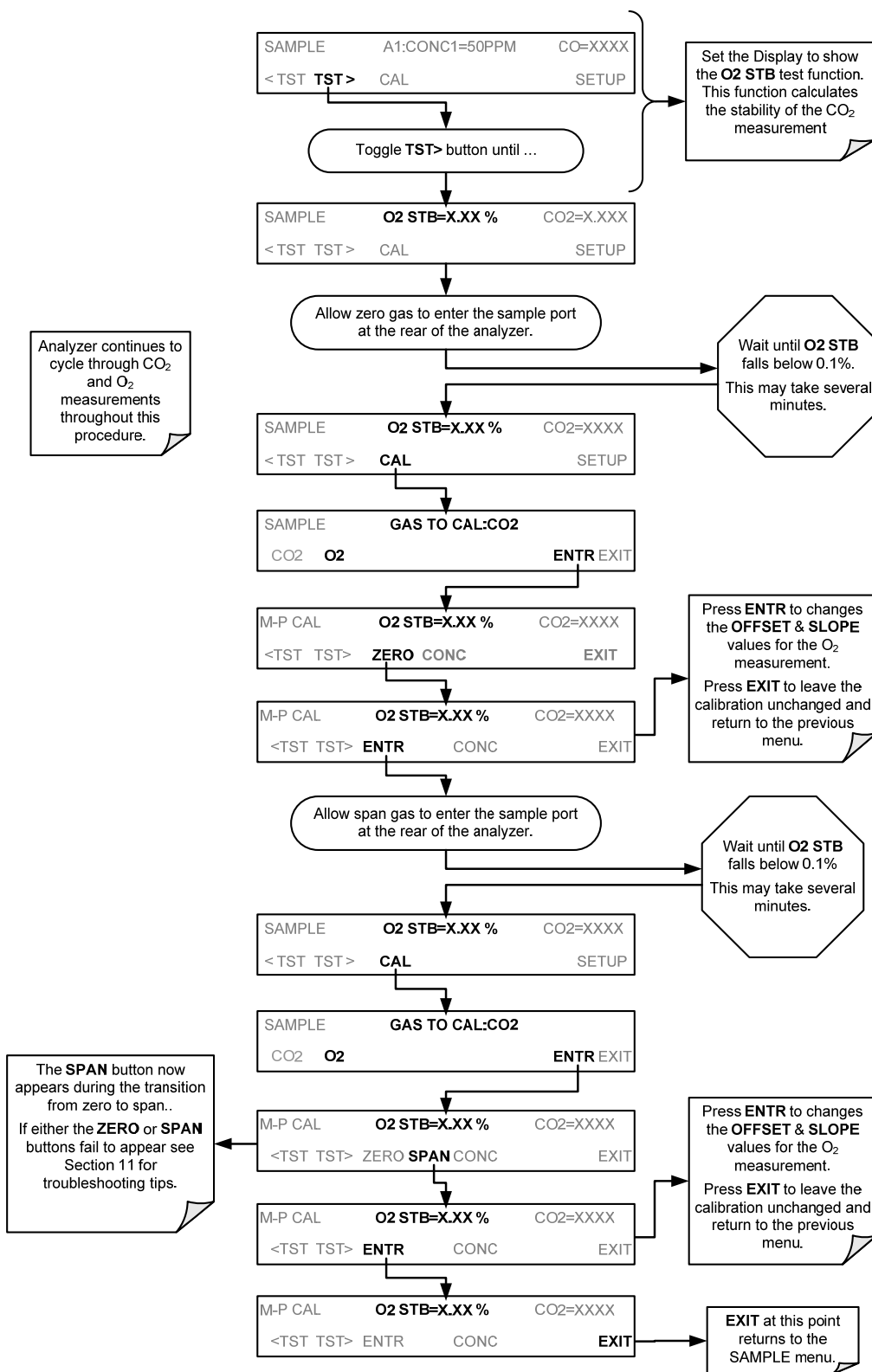

The Model GFC 7000T Analyzer is now ready for operation.

NOTE

Once you have completed the above set-up procedures, please fill out the Quality Questionnaire that was shipped with your unit and return it to Teledyne Instruments.

This information is vital to our efforts in continuously improving our service and our products.

THANK YOU.

4. FREQUENTLY ASKED QUESTIONS

4.1. FAQ's

The following is a list from the Teledyne Instruments' Customer Service Department of the most commonly asked questions relating to the Model CO₂ Analyzer.

Q: How do I get the instrument to zero / Why is the zero key not displayed?

A: See Section 11.3.4 Inability to zero.

Q: How do I get the instrument to span / Why is the span key not displayed?

A: See Section 11.3.3 Inability to span.

Q: Why does the **ENTR** key sometimes disappear on the Front Panel Display?

A: During certain types of adjustments or configuration operations, the **ENTR** key will disappear if you select a setting that is nonsensical (such as trying to set the 24-hour clock to 25:00:00) or out of the allowable range for that parameter (such as selecting a DAS Holdoff period of more than 20 minutes).

Once you adjust the setting in question to an allowable value, the **ENTR** key will re-appear.

Q: Is there an optional midpoint calibration?

A: There is an optional mid point linearity adjustment; however, midpoint adjustment is applicable only to applications where CO₂ measurements are expected above 100 ppm. Call Teledyne Instruments' Service Department for more information on this topic.

Q: How do I make the display and data logger analog input agree?

A: This most commonly occurs when an independent metering device is used besides the data logger/recorded to determine gas concentration levels while calibrating the analyzer. These disagreements result from the analyzer, the metering device and the data logger having slightly different ground levels.

Both the electronic scale and offset of the analog outputs can be adjusted (see Section 6.13.4.3). Alternately, use the data logger itself as the metering device during calibrations procedures.

Q: How do I perform a leak check?

A: See Section 8.3.2.

Q: How do I measure the sample flow?

A: Sample flow is measured by attaching a calibrated rotameter, wet test meter, or other flow-measuring device to the sample inlet port when the instrument is operating. The sample flow should be 800 cm³/min ±10%. See Section 9.3.4.

Q: How long does the IR source last?

A: Typical lifetime is about 2-3 years.



Q: How do I set up a SEQUENCE to run a nightly calibration check?

A: The setup of this option is located in Section 7.6.

Q: How do I set the analog output signal range and offset?

A: Instructions for this can be found in Section 6.13.4 which describes analog I/O configuration.

Q: What is the averaging time for the GFC 7000T?

A: The default averaging time, optimized for ambient pollution monitoring, is 150 seconds for stable concentrations and 10 seconds for rapidly changing concentrations; See Section 10.5.1 for more information. However, it is adjustable over a range of 0.5 second to 200 seconds (please contact customer service for more information).

4.2. Glossary

Note: Some terms in this glossary may not occur elsewhere in this manual.

Term	Description/Definition
10BaseT	an Ethernet standard that uses twisted ("T") pairs of copper wires to transmit at 10 megabits per second (Mbps)
100BaseT	same as 10BaseT except ten times faster (100 Mbps)
APICOM	name of a remote control program offered by Teledyne to its customers
ASSY	<i>Assembly</i>
CAS	<i>Code-Activated Switch</i>
CD	<i>Corona Discharge</i> , a frequently luminous discharge, at the surface of a conductor or between two conductors of the same transmission line, accompanied by ionization of the surrounding atmosphere and often by a power loss
CE	<i>Converter Efficiency</i> , the percentage of light energy that is actually converted into electricity
CEM	<i>Continuous Emission Monitoring</i>
Chemical formulas that may be included in this document:	
CO ₂	carbon dioxide
C ₃ H ₈	propane
CH ₄	methane
H ₂ O	water vapor
HC	general abbreviation for hydrocarbon
HNO ₃	nitric acid
H ₂ S	hydrogen sulfide
NO	nitric oxide
NO ₂	nitrogen dioxide

Term	Description/Definition
NO _x	nitrogen oxides, here defined as the sum of NO and NO ₂
NO _y	nitrogen oxides, often called odd nitrogen: the sum of NO _x plus other compounds such as HNO ₃ (definitions vary widely and may include nitrate (NO ₃), PAN, N ₂ O and other compounds as well)
NH ₃	ammonia
O ₂	molecular oxygen
O ₃	ozone
SO ₂	sulfur dioxide
cm ³	metric abbreviation for <i>cubic centimeter</i> (replaces the obsolete abbreviation "cc")
CPU	<i>Central Processing Unit</i>
DAC	<i>Digital-to-Analog Converter</i>
DAS	<i>Data Acquisition System</i>
DCE	<i>Data Communication Equipment</i>
DFU	<i>Dry Filter Unit</i>
DHCP	<i>Dynamic Host Configuration Protocol</i> . A protocol used by LAN or Internet servers to automatically set up the interface protocols between themselves and any other addressable device connected to the network
DIAG	<i>Diagnostics</i> , the diagnostic settings of the analyzer.
DOM	<i>Disk On Module</i> , a 44-pin IDE flash drive with up to 128MB storage capacity for instrument's firmware, configuration settings and data
DOS	<i>Disk Operating System</i>
DRAM	<i>Dynamic Random Access Memory</i>
DR-DOS	<i>Digital Research DOS</i>
DTE	<i>Data Terminal Equipment</i>
EEPROM	<i>Electrically Erasable Programmable Read-Only Memory</i> also referred to as a FLASH chip or drive
ESD	<i>Electro-Static Discharge</i>
ETEST	<i>Electrical Test</i>
Ethernet	a standardized (IEEE 802.3) computer networking technology for local area networks (LANs), facilitating communication and sharing resources
FEP	<i>Fluorinated Ethylene Propylene</i> polymer, one of the polymers that Du Pont markets as <i>Teflon</i> [®]
Flash	non-volatile, solid-state memory
FPI	<i>Fabry-Perot Interface</i> : a special light filter typically made of a transparent plate with two reflecting surfaces or two parallel, highly reflective mirrors
GFC	<i>Gas Filter Correlation</i>
I ² C bus	a clocked, bi-directional, serial bus for communication between individual analyzer components
IC	<i>Integrated Circuit</i> , a modern, semi-conductor circuit that can contain many basic components such as resistors, transistors, capacitors etc in a miniaturized

Term	Description/Definition
	package used in electronic assemblies
IP	<i>Internet Protocol</i>
IZS	<i>Internal Zero Span</i>
LAN	<i>Local Area Network</i>
LCD	<i>Liquid Crystal Display</i>
LED	<i>Light Emitting Diode</i>
LPM	<i>Liters Per Minute</i>
MFC	<i>Mass Flow Controller</i>
M/R	<i>Measure/Reference</i>
MOLAR MASS	<p>the mass, expressed in grams, of 1 mole of a specific substance. Conversely, one mole is the amount of the substance needed for the molar mass to be the same number in grams as the atomic mass of that substance.</p> <p>EXAMPLE: The atomic weight of Carbon is 12 therefore the molar mass of Carbon is 12 grams. Conversely, one mole of carbon equals the amount of carbon atoms that weighs 12 grams.</p> <p>Atomic weights can be found on any Periodic Table of Elements.</p>
NDIR	<i>Non-Dispersive Infrared</i>
NIST-SRM	<i>National Institute of Standards and Technology - Standard Reference Material</i>
PC	<i>Personal Computer</i>
PCA	<i>Printed Circuit Assembly, the PCB with electronic components, ready to use</i>
PC/AT	<i>Personal Computer / Advanced Technology</i>
PCB	<i>Printed Circuit Board, the bare board without electronic component</i>
PFA	<i>Per-Fluoro-Alkoxy, an inert polymer; one of the polymers that Du Pont markets as Teflon®</i>
PLC	<i>Programmable Logic Controller, a device that is used to control instruments based on a logic level signal coming from the analyzer</i>
PLD	<i>Programmable Logic Device</i>
PLL	<i>Phase Lock Loop</i>
PMT	<i>Photo Multiplier Tube, a vacuum tube of electrodes that multiply electrons collected and charged to create a detectable current signal</i>
P/N (or PN)	<i>Part Number</i>
PSD	<i>Prevention of Significant Deterioration</i>
PTFE	<i>Poly-Tetra-Fluoro-Ethylene, a very inert polymer material used to handle gases that may react on other surfaces; one of the polymers that Du Pont markets as Teflon®</i>
PVC	<i>Poly Vinyl Chloride, a polymer used for downstream tubing</i>
Rdg	Reading
RS-232	specification and standard describing a serial communication method between DTE (Data Terminal Equipment) and DCE (Data Circuit-terminating Equipment) devices, using a maximum cable-length of 50 feet
RS-485	specification and standard describing a binary serial communication method

Term	Description/Definition
	among multiple devices at a data rate faster than RS-232 with a much longer distance between the host and the furthest device
SAROAD	<i>Storage and Retrieval of Aerometric Data</i>
SLAMS	<i>State and Local Air Monitoring Network Plan</i>
SLPM	<i>Standard Liters Per Minute</i> of a gas at standard temperature and pressure
STP	<i>Standard Temperature and Pressure</i>
TCP/IP	<i>Transfer Control Protocol / Internet Protocol</i> , the standard communications protocol for Ethernet devices
TEC	<i>Thermal Electric Cooler</i>
TPC	<i>Temperature/Pressure Compensation</i>
USB	<i>Universal Serial Bus</i> : a standard connection method to establish communication between peripheral devices and a host controller, such as a mouse and/or touchscreen and a personal computer or laptop
VARS	<i>Variables</i> , the variable settings of the instrument
V-F	<i>Voltage-to-Frequency</i>
Z/S	<i>Zero / Span</i>

This page intentionally left blank.

5. OPTIONAL HARDWARE AND SOFTWARE

This includes a brief description of the hardware and software options available for the Model GFC 7000T Gas Filter Correlation Carbon Dioxide Analyzer. For assistance with ordering these options please contact the Sales department of Teledyne Analytical Instruments at:

TELEDYNE ELECTRONIC TECHNOLOGIES *Analytical Instruments*

16830 Chestnut Street
City of Industry, CA 91748
Telephone: (626) 934-1500
Fax: (626) 961-2538
Web: www.teledyne-ai.com

5.1. Rack Mount Kits (Options 20A, 20B, 21 and 23)

OPTION NUMBER	DESCRIPTION
20A	Rack mount brackets with 26 in. chassis slides.
20B	Rack mount brackets with 24 in. chassis slides.
21	Rack mount brackets only
23	Rack Mount for External Pump Pack (No Slides).

Each of these options permits the Analyzer to be mounted in a standard 19" x 30" RETMA rack.

5.2. Current Loop Analog Outputs (Option 41)

This option adds isolated, voltage-to-current conversion circuitry to the analyzer's analog outputs. This option may be ordered separately for any of the analog outputs; it can be installed at the factory or added later. Call TAI sales for pricing and availability.

The current loop option can be configured for any output range between 0 and 20 mA. Figure 5-1 provides installation instructions and illustrates a sample combination of one current output and two voltage outputs configuration. Information on calibrating or adjusting these outputs can be found in Section 6.13.4.4.

J19, J21, J23 Analog Output Setup:

- For **voltage** output of any one, two, or all:
 1. Jumper two leftmost pins.
 2. Jumper next two leftmost pins.
 3. Calibrate per Analog I/O Configuration menu.
- For **current** output of any one, two, or all:
 1. Remove jumper shunts.
 2. Install Current Loop option.
 3. Calibrate per Analog I/O Configuration menu.

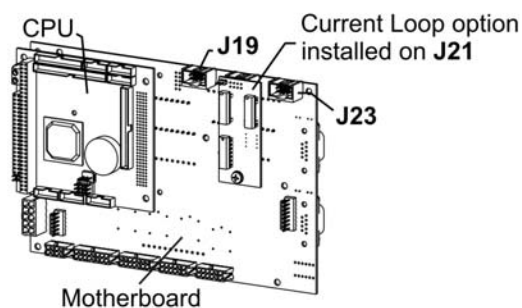
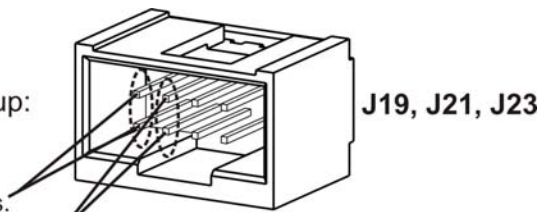

Example setup: install jumper shunts for voltage output on J19 and J23; remove jumper shunts and install Current Loop option for current output on J21.

Figure 5-1: Current Loop Option Installed on the Motherboard

5.2.1. Converting Current Loop Analog Outputs to Standard Voltage Outputs

NOTE

Servicing or handling of circuit components requires electrostatic discharge protection, i.e. ESD grounding straps, mats and containers. Failure to use ESD protection when working with electronic assemblies will void the instrument warranty.

See Section 12 for more information on preventing ESD damage.

To convert an output configured for current loop operation to the standard 0 to 5 VDC output operation:

1. Turn off power to the analyzer.
2. If a recording device was connected to the output being modified, disconnect it.
3. Remove the top cover

- Remove the set screw located in the top, center of the rear panel
- Remove the screws fastening the top cover to the unit (four per side).
- Slide the cover back and lift straight up .
4. Disconnect the current loop option PCA from the appropriate connector on the motherboard (see Figure 5-1).
5. Place a shunt between the leftmost two pins of the connector (see Figure 5-1).
6. Reattach the top case to the analyzer.
7. The analyzer is now ready to have a voltage-sensing, recording device attached to that output

5.3. Expendable Kits (Options 42C, 42D and 43)

OPTION NUMBER	DESCRIPTION
OPT 42C	1 year's supply of replacement of 47mm dia. particulate filters
OPT 42D	1 full replacement's volume of indicating soda-lime for the external CO ₂ scrubber included with options 51 & 53 (approximate active lifetime: 1 year)
OPT 43	Options 42 C & 42D

5.4. Calibration Valves Options

In the basic configuration, sample source and calibration gas are switched either manually by disconnecting/connecting gas lines or through the customer's own switching manifold. This option provides a convenient way for introducing calibration gases to the analyzer without having to manually disconnect the sample input line.

This option requires that both zero air and span gas be supplied from external sources such as a pressurized bottle of calibrated CO₂ gas or where zero air is supplied by a zero air generator like a bottle of N₂ and span gas are being supplied by Gas Dilution Calibrator like the Teledyne Instruments Model 700 or 702. Internal zero/span and sample/cal valves control the flow of gas through the instrument.

Keep in mind, however, that the standard Model GFC 7000T has no significant internal restriction or adjustable valve to control/adjust flow. Sample or cal gas must be introduced to the inlet fitting at a fraction of a PSI above ambient pressure, just enough to drive the flow to the proper value range. Depending on the ultimate sample source pressure, a needle valve, restrictor, critical orifice or combination there should be deployed to achieve this. Do not directly apply significant pressure to the inlet of the unit under any circumstances, as damage / and or personal injury may result.

In order to ensure that span gas does not migrate backwards through the vent line and alter the concentration of the span gas, a gas line not less than 2 meters in length should be attached to the vent span outlet on the rear panel of the analyzer. To prevent the buildup of back pressure, this vent line should not be greater than 10 meters in length.

The following table describes the state of each valve during the analyzer's various operational modes.

Table 5-1: Zero/Span Valve Operating States

Mode	Valve	Condition
SAMPLE (Normal State)	Sample/Cal	Open to SAMPLE inlet
	Zero/Span	Open to IZS inlet
ZERO CAL	Sample/Cal	Open to ZERO/SPAN valve
	Zero/Span	Open to IZS inlet
SPAN CAL	Sample/Cal	Open to ZERO/SPAN valve
	Zero/Span	Open to PRESSURE SPAN inlet

The minimum span gas flow rate required for this option is 800 cm³/min.

The state of the zero/span valves can also be controlled:

- Manually from the analyzer's front panel by using the **SIGNAL I/O** controls located under the **DIAG** Menu (Section 6.13.2),
- By activating the instrument's AutoCal feature (Section 7.6),
- Remotely by using the external digital control inputs (Section 6.15.1.2 and Section 7.5.2), or;
- Remotely through the RS-232/485 serial I/O ports (see Appendix A-6 for the appropriate commands).

Figure 5-2 depicts the internal gas flow for models with zero/span valve option. It also shows an optional external CO₂ scrubber on the zero gas input line.

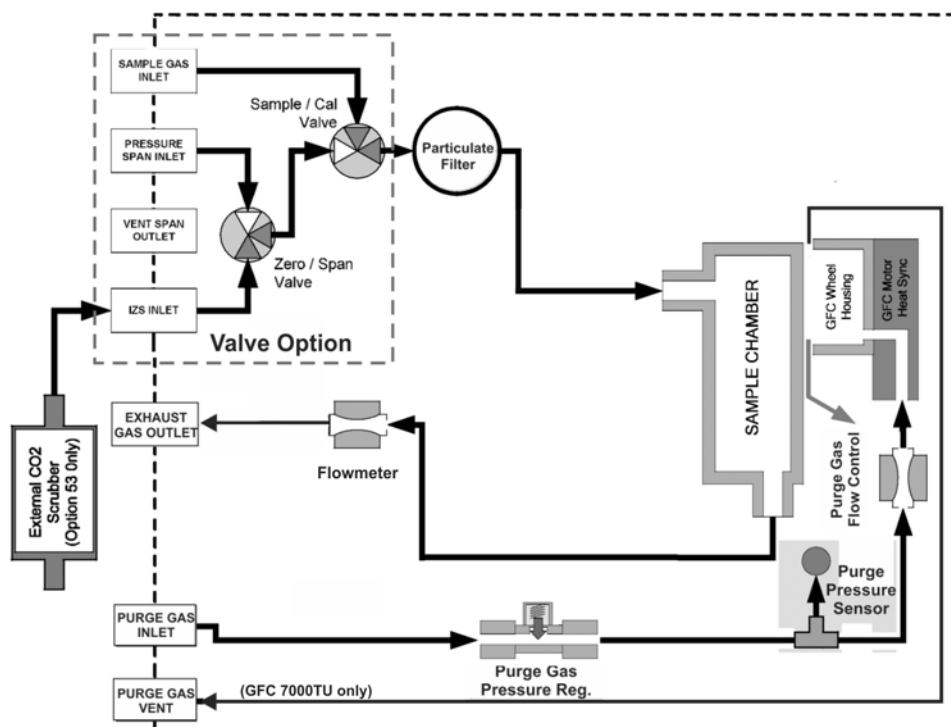

Figure 5-2: Internal Pneumatic Flow –with Zero/Span Valve Option

5.5. Communication Options

5.5.1. Communications Cables

Type	Description
60A	RS-232 Shielded, straight-through DB-9F to DB-25M cable, about 1.8 m long. Used to interface with older computers or code activated switches with DB-25 serial connectors.
60B	RS-232 Shielded, straight-through DB-9F to DB-9F cable of about 1.8 m length.
60C	Ethernet Patch cable, 2 meters long, used for Internet and LAN communications.
60D	USB Cable for direct connection between instrument (rear panel USB port) and PC or laptop computer.

5.5.2. RS-232 Multidrop (Option 62)

The multidrop option is used with any of the RS-232 serial ports to enable communications of up to eight analyzers with the host computer over a chain of RS-232 cables via the instruments COM1 port (labeled **RS232**). It is subject to the distance limitations of the RS 232 standard.

The option consists of a small printed circuit assembly, which is seated on the analyzer's CPU card (see Figure 5-3) and is connected to the RS-232 and COM2 DB9 connectors on the instrument's back panel via a cable to the motherboard. One option 62 is required for each analyzer along with one 6' straight-through, DB9 male → DB9 Female cable (P/N WR0000101).

For information on using and setting up this option (See Section 6.11.7)

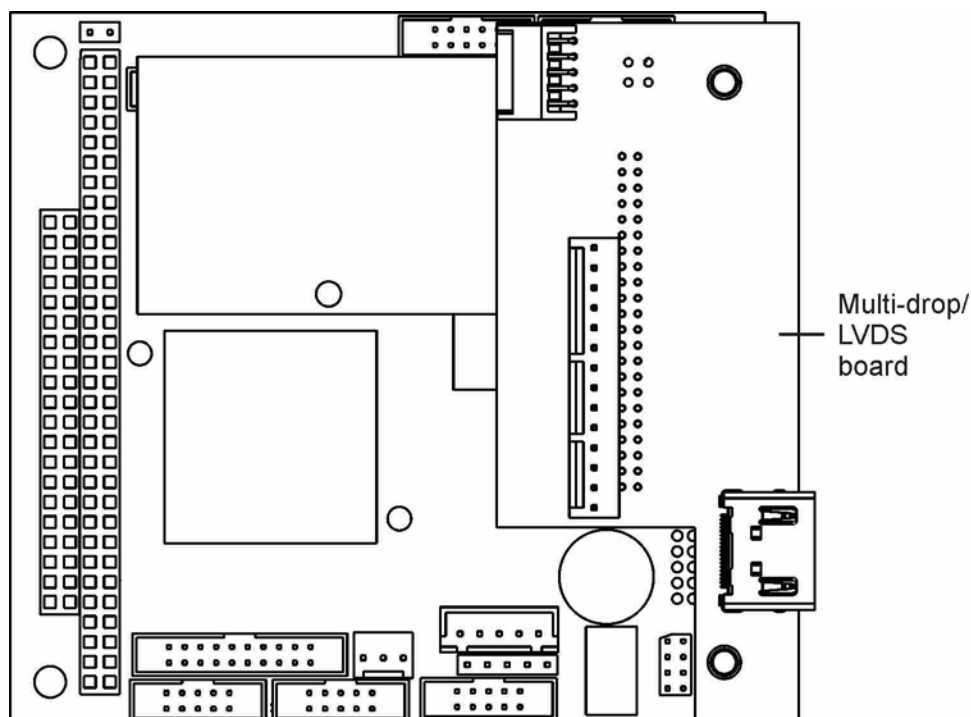

Figure 5-3: Multi-drop/LVDS PCA Seated on CPU

5.6. Oxygen Sensor (OPT 65)

5.6.1. Theory of Operation

5.6.1.1. Paramagnetic measurement of O₂

The oxygen sensor used in the GFC 7000T analyzer utilizes the fact that oxygen is attracted into strong magnetic field; most other gases are not, to obtain fast, accurate oxygen measurements.

The sensor's core is made up of two nitrogen filled glass spheres, which are mounted on a rotating suspension within a magnetic field (Figure 5-4). A mirror is mounted centrally on the suspension and light is shone onto the mirror that reflects the light onto a pair of photocells. The signal generated by the photocells is passed to a feedback loop, which outputs a current to a wire winding (in effect, a small DC electric motor) mounted on the suspended mirror.

Oxygen from the sample stream is attracted into the magnetic field displacing the nitrogen filled spheres and causing the suspended mirror to rotate. This changes the amount of light reflected onto the photocells and therefore the output levels of the photocells. The feedback loop increases the amount of current fed into the winding in order to move the mirror back into its original position. The more O₂ present, the more the mirror moves and the more current is fed into the winding by the feedback control loop.

A sensor measures the amount of current generated by the feedback control loop which is directly proportional to the concentration of oxygen within the sample gas mixture (see Figure 5-7).

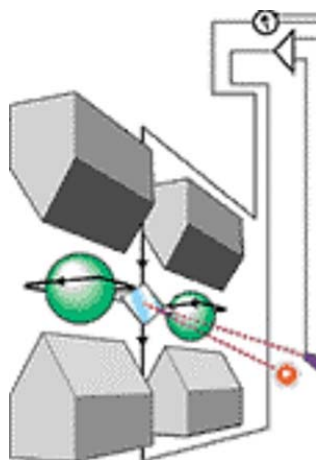

Figure 5-4: Oxygen Sensor - Principle of Operation

5.6.1.2. Operation within the GFC 7000T Analyzer

The oxygen sensor option is transparently integrated into the core analyzer operation. All functions can be viewed or accessed through the front panel, just like the functions for CO₂

- The O₂ concentration is displayed in the upper right-hand corner, alternating with CO₂ concentration.
- Test functions for O₂ slope and offset are viewable from the front panel along with the analyzer's other test functions.
- O₂ sensor calibration is performed via the front panel **CAL** function and is performed in a nearly identical manner as the standard CO₂ calibration. See Section 3.3.1 for more details.
- Stability of the O₂ sensor can be viewed via the front panel (see Section 3.3.2.1).
- A signal representing the currently measured O₂ concentration is available.

The O₂ concentration range is 0-100% (user selectable) with 0.1% precision and accuracy and is available to be output via the instrument's analog output channel **A3** (See Section 6.13.4).

The temperature of the O₂ sensor is maintained at a constant 50° C by means of a PID loop and can be viewed on the front panel as test function **O2 TEMP**.

The O₂ sensor assembly itself does not have any serviceable parts and is enclosed in an insulated canister.

5.6.1.3. Pneumatic Operation of the O₂ Sensor

- Pneumatically, the O₂ sensor is connected to the bypass manifold and draws a flow of about 120 cm³/min in addition to the normal sample flow rate and is separately controlled with its own critical flow orifice. Figure 5-5 shows the internal pneumatics of the GFC 7000T with the O₂ Sensor installed.

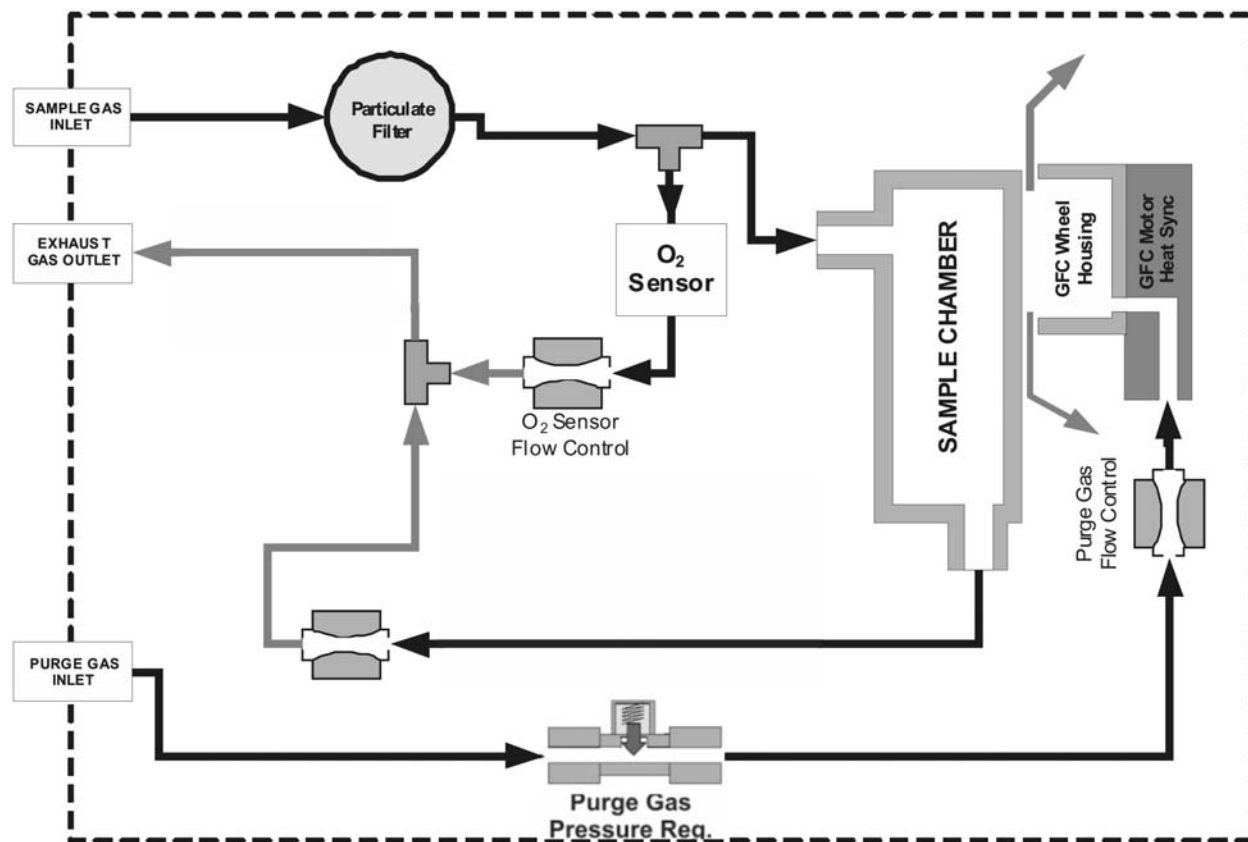

Figure 5-5: GFC 7000T – Internal Pneumatics with O₂ Sensor Option 65

5.7. Special Features

5.7.1. Dilution Ratio Option

The Dilution Ratio Option is a software option that is designed for applications where the Sample gas is diluted before being analyzed by the Model GFC 7000T. Typically this occurs in Continuous Emission Monitoring (CEM) applications where the quality of gas in a smoke stack is being tested and the sampling method used to remove the gas from the stack dilutes the gas.

Once the degree of dilution is known, this feature allows the user to add an appropriate scaling factor to the analyzer's CO₂ concentration calculation so that the Measurement Range and concentration values displayed on the instrument's Front Panel Display and reported via the Analog and Serial Outputs reflect the undiluted values.

Instructions for using the dilution ratio option can be found in Section 6.8.7.

5.7.2. Maintenance Mode Switch

TAI's instruments can be equipped with a switch that places the instrument in maintenance mode. When present, the switch accessed by opening the hinged front panel and is located on the rearward facing side of the display/touchscreen driver PCA; on the left side; near the particulate filter.

When in maintenance mode the instrument ignores all commands received via the com ports that alter the operation state of the instrument. This includes all calibration commands, diagnostic menu commands and the reset instrument command. The instrument continues to measure concentration and send data when requested.

This option is of particular use for instruments connected to multidrop networks.

5.7.3. Second Language Switch

TAI's instruments can be equipped with switch that activates an alternate set of display message in a language other than the instruments default language. When present, the switch accessed by opening the hinged front panel and is located on the rearward facing side of the display/touchscreen driver PCA; on the right side.

To activate this feature, the instrument must also have a specially programmed Disk on Chip containing the second language.

This page intentionally left blank.

6. OPERATING INSTRUCTIONS

To assist in navigating the analyzer's software, a series of menu trees can be found in Appendix A-1 of this manual.

NOTES

The flow charts appearing in this contain typical representations of the analyzer's display during the various operations being described. These representations may differ slightly from the actual display of your instrument.

The ENTR button may disappear if you select a setting that is invalid or out of the allowable range for that parameter, such as trying to set the 24-hour clock to 25:00:00. Once you adjust the setting to an allowable value, **the ENTR button will re-appear.**

6.1. Overview of Operating modes

The GFC 7000T software has a variety of operating modes. Most commonly, the analyzer will be operating in **SAMPLE** mode. In this mode, a continuous read-out of the CO₂ concentration is displayed on the front panel and output as an analog voltage from rear panel terminals, calibrations can be performed, and **TEST** functions and **WARNING** messages can be examined.

The second most important operating mode is **SETUP** mode. This mode is used for performing certain configuration operations, such as for the DAS system, the reporting ranges, or the serial (RS-232/RS-485/Ethernet) communication channels. The **SET UP** mode is also used for performing various diagnostic tests during troubleshooting.

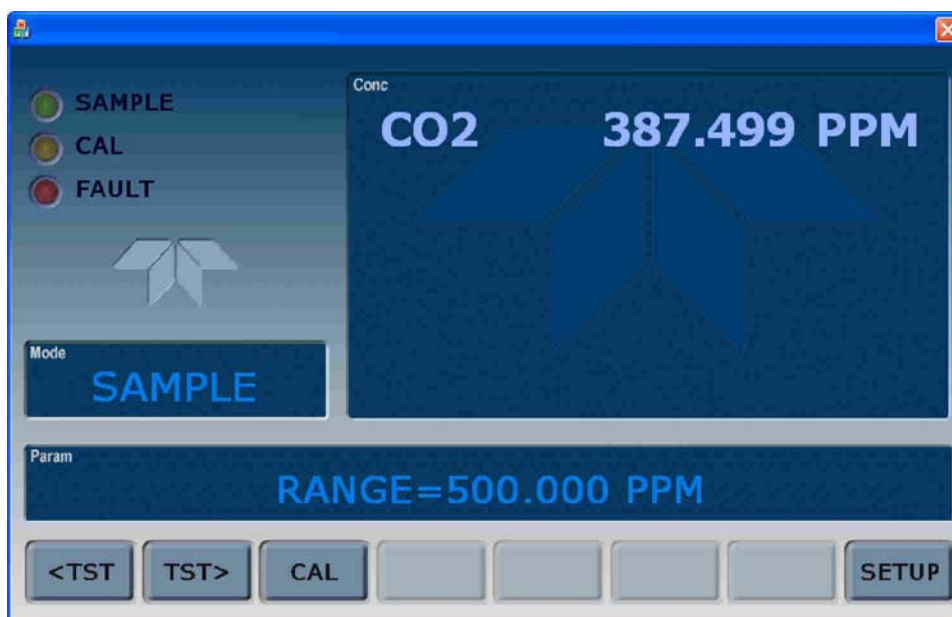

Figure 6-1: Front Panel Display

The Mode field of the front panel display indicates to the user which operating mode the unit is currently running.

Besides **SAMPLE** and **SETUP**, other modes the analyzer can be operated in are:

Table 6-1: Analyzer Operating modes

MODE	MEANING
DIAG	One of the analyzer's diagnostic modes is being utilized (See Section 6.13).
M-P CAL	This is the basic, multi-point calibration mode of the instrument and is activated by pressing the CAL key.
SAMPLE	Sampling normally, flashing indicates adaptive filter is on.
SAMPLE A	Indicates that unit is in SAMPLE Mode and AUTOCAL feature is activated.
SETUP ¹	SETUP mode is being used to configure the analyzer (CO ₂ sampling will continue during this process).
SPAN CAL A	Unit is performing span cal procedure initiated automatically by the analyzer's AUTOCAL feature.
SPAN CAL M	Unit is performing span cal procedure initiated manually by the user.
SPAN CAL R	Unit is performing span cal procedure initiated remotely via the RS-232, RS-4485 or digital i/o control inputs.
ZERO CAL A	Unit is performing zero cal procedure initiated automatically by the analyzer's AUTOCAL feature.
ZERO CAL M	Unit is performing zero cal procedure initiated manually by the user.
ZERO CAL R	Unit is performing zero cal procedure initiated remotely via the RS-232, RS-4485 or digital I/O control inputs.

¹ The revision of the Teledyne Instruments software installed in this analyzer will be displayed following the word **SETUP**. E.g. "SETUP G.4"

Finally, the various **CAL** modes allow calibration of the analyzer. Because of its importance, this mode is described separately in Section 7.

6.2. Sample Mode

This is the analyzer's standard operating mode. In this mode the instrument is analyzing the gas in the sample chamber, calculating CO₂ concentration and reporting this information to the user via the front panel display, the analog outputs and, if set up properly, the RS-232/485/Ethernet ports.

NOTE

A value of "XXXX" displayed in the CO₂ Concentration field means that the M/R ratio is invalid because CO₂ REF is either too high (> 4950 mVDC) or too low (< 1250 VDC).

6.2.1. Test Functions

Test functions are shown on the front panel display while the analyzer is in **SAMPLE** mode. They provide information about the present operating status of the instrument and can be used troubleshooting and can be recorded in one of the DAS channels (Section 6.7) for data analysis. To view, press the <TST TST> buttons.

Table 6-2: Test Functions Defined

PARAMETER	DISPLAY	UNITS	MEANING
Range	RANGE RANGE1¹ RANGE2¹	PPB, PPM, UGM, MGM	The full scale limit at which the reporting range of the analyzer is currently set. THIS IS NOT the Physical Range of the instrument. See Section 6.8.1 for more information.
O ₂ Range	O2 RANGE	%	The range setting for the O ₂ Sensor
Stability	STABIL	PPB, PPM UGM, MGM	Standard deviation of CO ₂ concentration readings. Data points are recorded every ten seconds using the last 25 data points.
CO ₂ Measure	MEAS	MV	The demodulated, peak IR detector output during the measure portion of the GFC Wheel cycle.
CO ₂ Reference	REF	MV	The demodulated, peak IR detector output during the reference portion of the GFC wheel cycle.
Measurement / Reference Ratio	MR Ratio	-	The result of CO2 MEAS divided by CO2 REF . This ratio is the primary value used to compute CO ₂ concentration. The value displayed is not linearized.
Sample Pressure	PRES	In-Hg-A	The absolute pressure of the Sample gas as measured by a pressure sensor located inside the sample chamber.
Purge Pressure ³	PURGE	PSIG	Wheel housing purge pressure.
Sample Flow	SAMPLE FL	cc/min	Sample mass flow rate. This is computed from the differential between the pressures measured up-stream and down-stream of the sample critical flow orifice pressures.
Sample Temperature	SAMP TEMP	°C	The temperature of the gas inside the sample chamber.
Bench Temperature	BENCH TEMP	°C	Optical bench temperature.
Wheel Temperature	WHEEL TEMP	°C	Filter wheel temperature.
Box Temperature	BOX TEMP	°C	The temperature inside the analyzer chassis.
O ₂ Cell Temperature ²	O2 CELL TEMP²	°C	O ₂ sensor cell temperature.
Photo-detector Temp. Control Voltage	PHT DRIVE	mV	The drive voltage being supplied to the thermoelectric coolers of the IR photo-detector by the sync/demod Board.
Slope	SLOPE	-	The sensitivity of the instrument as calculated during the last calibration activity. The SLOPE parameter is used to set the span calibration point of the analyzer.
Offset	OFFSET	-	The overall offset of the instrument as calculated during the last calibration activity. The OFFSET parameter is used to set the zero point of the analyzer response.
O ₂ Sensor Slope ²	O2 SLOPE	-	O ₂ slope, computed during zero/span calibration.
O ₂ Sensor Offset ²	O2 OFFSET	-	O ₂ offset, computed during zero/span calibration.
Test channel output signal	TEST	mV, mA	Displays the signal level of the TEST analog output channel. Only appears when the TEST channel has been activated.
Current Time	TIME	-	The current time. This is used to create a time stamp on DAS readings, and by the AUTOCAL feature to trigger calibration events.

¹ Only appears when the instrument's reporting range mode is set for **DUAL** or **AUTO**

² Only appears when the optional O₂ sensor is installed.

³ GFC7000TU only.

To view the TEST Functions press:

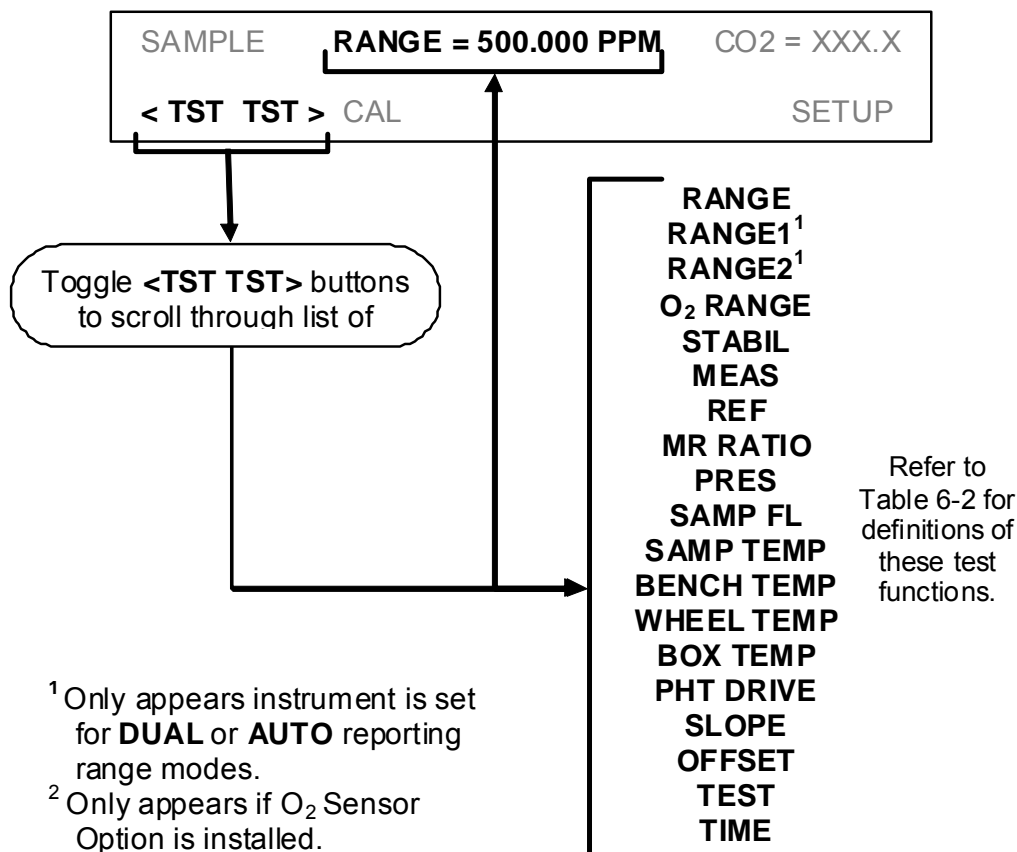

¹ Only appears instrument is set for **DUAL** or **AUTO** reporting range modes.

² Only appears if O₂ Sensor Option is installed.

Figure 6-2: Viewing TEST Functions

NOTE

A value of "XXXX" displayed for any of the TEST functions indicates an out-of-range reading or the analyzer's inability to calculate it.

All pressure measurements are represented in terms of absolute pressure. Absolute, atmospheric pressure is 29.92 in-Hg-A at sea level. It decreases about 1 in-Hg per 300 m gain in altitude. A variety of factors such as air conditioning and passing storms can cause changes in the absolute atmospheric pressure.

6.2.2. Warning Messages

The most common instrument failures will be reported as a warning on the analyzer's front panel and through the COM ports. Section 11.1.1 explains how to use these messages to troubleshoot problems. Section 3.2.3 shows how to view and clear warning messages.

Table 6-3 lists all warning messages for the current version of software.

Table 6-3: List of Warning Messages

MESSAGE	MEANING
ANALOG CAL WARNING	The instrument's A/D circuitry or one of its analog outputs is not calibrated.
BENCH TEMP WARNING	The Temperature of the optical bench is outside the specified limits.
BOX TEMP WARNING	Remote span calibration failed while the dynamic span feature was set to turned on
CANNOT DYN SPAN	Remote zero calibration failed while the dynamic zero feature was set to turned on
CANNOT DYN ZERO	Configuration was reset to factory defaults or was erased.
CONC ALRM1 WARNING	Concentration alarm 1 is enabled and the measured CO ₂ level is \geq the set point.
CONC ALRM2 WARNING	Concentration alarm 2 is enabled and the measured CO ₂ level is \geq the set point.
CONFIG INITIALIZED	Configuration storage was reset to factory configuration or erased.
DATA INITIALIZED	DAS data storage was erased.
O2 CELL TEMP WARN	O ₂ sensor cell temperature outside of warning limits.
PHOTO TEMP WARNING	The temperature of the IR photometer is outside the specified limits.
REAR BOARD NOT DET	The CPU is unable to communicate with the motherboard.
RELAY BOARD WARN	The firmware is unable to communicate with the relay board.
SAMPLE FLOW WARN	The flow rate of the sample gas is outside the specified limits.
SAMPLE PRESS WARN	Sample gas pressure outside of operational parameters.
SAMPLE TEMP WARN	The temperature of the sample gas is outside the specified limits.
SOURCE WARNING	The IR source may be faulty.
SYSTEM RESET	The computer was rebooted.
WHEEL TEMP WARNING	The Gas Filter Correlation wheel temperature is outside the specified limits.

To view and clear warning messages:

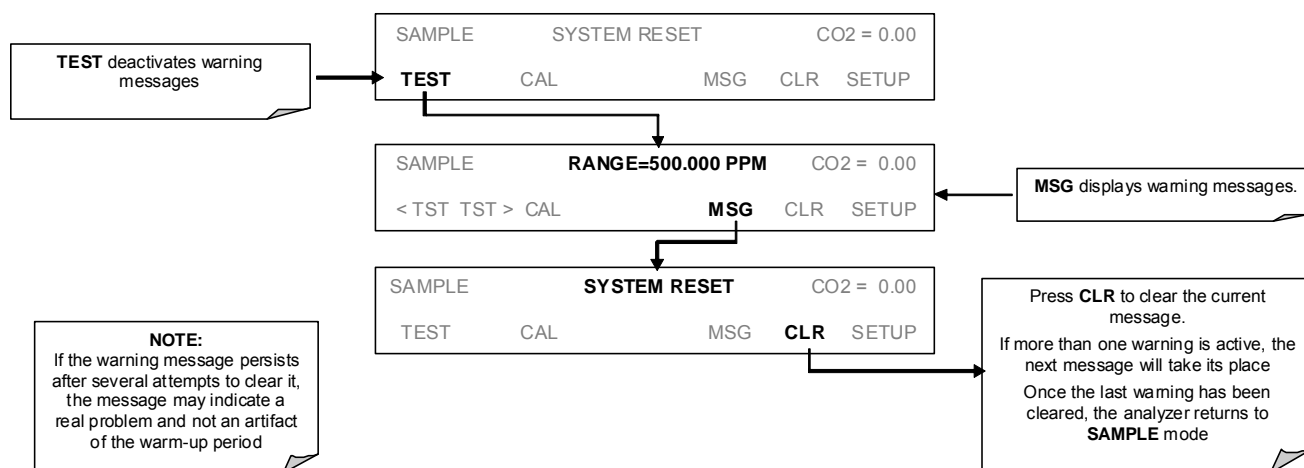

Figure 6-3: Viewing and Clearing GFC 7000T WARNING Messages

6.3. Calibration Mode

Pressing the **CAL** key switches the GFC 7000T into multi-point calibration mode. In this mode, the user can calibrate the instrument or check the instrument's calibration with the use of calibrated zero or span gases.

If the instrument includes either the zero/span valve option or IZS option, the display will also include **CALZ** and **CALS** keys. Pressing either of these keys also puts the instrument into multipoint calibration mode.

- The **CALZ** key is used to initiate a calibration of the zero point.
- The **CALS** key is used to calibrate the span point of the analyzer. It is recommended that this span calibration is performed at 90% of full scale of the analyzer's currently selected reporting range.

Because of their critical importance and complexity, calibration operations are described in detail in Section 7 of this manual. For more information concerning the zero/span, zero/span and IZS valve options, See Section 5.4.

6.4. SETUP MODE

The **SETUP** mode contains a variety of choices that are used to configure the analyzer's hardware and software features, perform diagnostic procedures, gather information on the instruments performance and configure or access data from the internal data acquisition system (DAS). For a visual representation of the software menu trees, refer to Appendix A. The areas access under the Setup mode are:

Table 6-4: Primary Setup Mode Features and Functions

MODE OR FEATURE	TOUCHSCREEN BUTTON	DESCRIPTION	MANUAL SECTION
Analyzer Configuration	CFG	Lists key hardware and software configuration information	6.5
Auto Cal Feature	ACAL	Used to set up and operate the AutoCal feature. Only appears if the analyzer has one of the internal valve options installed	7.6
Internal Data Acquisition (DAS)	DAS	Used to set up the DAS system and view recorded data	6.7
Analog Output Reporting Range Configuration	RNGE	Used to configure the output signals generated by the instruments Analog outputs.	6.8
Calibration Password Security	PASS	Turns the calibration password feature ON/OFF	6.9
Internal Clock Configuration	CLK	Used to Set or adjust the instrument's internal clock	6.10
Advanced SETUP Features	MORE	This button accesses the instruments secondary setup menu	See Table 6-5

Table 6-5: Secondary Setup Mode Features and Functions

MODE OR FEATURE	TOUCHSCREEN BUTTON	DESCRIPTION	MANUAL SECTION
External Communication Channel Configuration	COMM	Used to set up and operate the analyzer's various external I/O channels including RS-232; RS-485, modem communication and/or Ethernet access.	6.11 & 6.15
System Status Variables	VARs	Used to view various variables related to the instruments current operational status	6.12
System Diagnostic Features	DIAG	Used to access a variety of functions that are used to configure, test or diagnose problems with a variety of the analyzer's basic systems	6.13
CO ₂ Concentration Alarms	ALRM	Used to activate the analyzer's two gas concentration status alarms and set the alarm limits	6.14

NOTE

Any changes made to a variable during one of the following procedures is not acknowledged by the instrument until the ENTR button is pressed

If EXIT is pressed before the ENTR button, the analyzer will beep alerting the user that the newly entered value has been lost.

6.5. SETUP → CFG: Viewing the Analyzer’s Configuration Information

Pressing the CFG button displays the instrument configuration information. This display lists the analyzer model, serial number, firmware revision, software library revision, CPU type and other information. Use this information to identify the software and hardware when contacting customer service. Special instrument or software features or installed options may also be listed here.

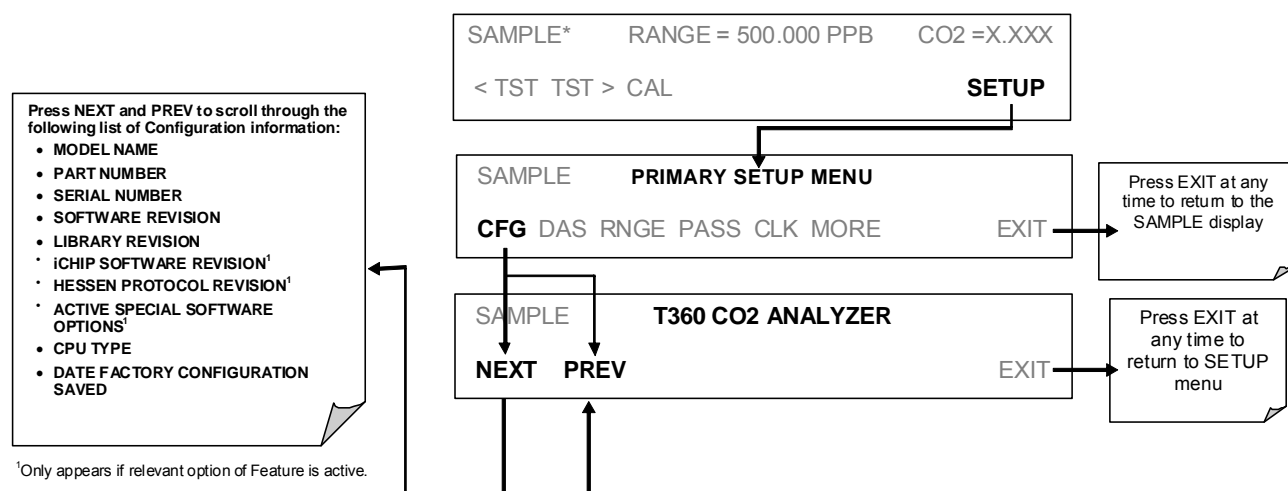

6.6. SETUP → ACAL: Automatic Calibration

Instruments with one of the internal valve options installed can be set to automatically run calibration procedures and calibration checks. These automatic procedures are programmed using the submenus and functions found under the **ACAL** menu.

A menu tree showing the **ACAL** menu’s entire structure can be found in Appendix A-1 of this manual.

Instructions for using the **ACAL** feature are located in the Section 7.6 of this manual along with all other information related to calibrating the analyzer.

6.7. SETUP → DAS: Using the Data Acquisition System (DAS)

The GFC 7000T analyzer contains a flexible and powerful, internal data acquisition system (DAS) that enables the analyzer to store concentration and calibration data as well as a host of diagnostic parameters. The DAS of the GFC 7000T can store up to about one million data points, which can, depending on individual configurations, cover days, weeks or months of valuable measurements. The data are stored in non-volatile memory and are retained even when the instrument is powered off. Data are stored in plain text format for easy retrieval and use in common data analysis programs (such as spreadsheet-type programs).

The DAS is designed to be flexible, users have full control over the type, length and reporting time of the data. The DAS permits users to access stored data through the instrument's front panel or its communication ports. Using APICOM, data can even be retrieved automatically to a remote computer for further processing.

The principal use of the DAS is logging data for trend analysis and predictive diagnostics, which can assist in identifying possible problems before they affect the functionality of the analyzer. The secondary use is for data analysis, documentation and archival in electronic format.

To support the DAS functionality, Teledyne Instruments offers APICOM, a program that provides a visual interface for remote or local setup, configuration and data retrieval of the DAS (Section 6.7). The APICOM manual, which is included with the program, contains a more detailed description of the DAS structure and configuration.

The GFC 7000T is configured with a basic DAS configuration, which is enabled by default. New data channels are also enabled by default but each channel may be turned off for later or occasional use. Note that DAS operation is suspended while its configuration is edited through the front panel. To prevent such data loss, it is recommended to use the APICOM graphical user interface for DAS changes.

The green SAMPLE LED on the instrument front panel, which indicates the analyzer status, also indicates certain aspects of the DAS status:

Table 6-6: Front Panel Sample LED Status Indicators for DAS

LED STATE	DAS Status
OFF	System is in calibration mode. Data logging can be enabled or disabled for this mode. Calibration data are typically stored at the end of calibration periods, concentration data are typically not sampled, diagnostic data should be collected.
BLINKING	Instrument is in hold-off mode, a short period after the system exits calibrations. IDAS channels can be enabled or disabled for this period. Concentration data are typically disabled whereas diagnostic should be collected.
ON	Sampling normally.

The DAS can be disabled only by disabling or deleting its individual data channels.

6.7.1. DAS Structure

The DAS is designed around the feature of a “record”. A record is a single data point of one parameter, stored in one (or more) data channels and generated by one of several triggering event. The entire DAS configuration is stored in a script, which can be edited from the front panel or downloaded, edited and uploaded to the instrument in form of a string of plain-text lines through the communication ports.

DAS data are defined by the PARAMETER type and are stored through different triggering EVENTS in data CHANNELS, which relate triggering events to data parameters and define certain operational functions related to the recording and reporting of the data.

6.7.1.1. DAS Channels

The key to the flexibility of the DAS is its ability to store a large number of combinations of triggering events and data parameters in the form of data channels. Users may create up to 20 data channels and each channel can contain one or more parameters. For each channel one triggering event is selected and up to 50 data parameters, which can be the same or different between channels. Each data channel has several properties that define the structure of the channel and allow the user to make operational decisions regarding the channel (Table 6-7).

Table 6-7: DAS Data Channel Properties

PROPERTY	DESCRIPTION	DEFAULT	SETTING RANGE
NAME	The name of the data channel.	“NONE”	Up to 6 letters and digits (more with APICOM, but only the first six are displayed on the front panel).
TRIGGERING EVENT	The event that triggers the data channel to measure and store its data parameters. See APPENDIX A-5 for a list of available triggering events.	ATIMER	See Appendix A-5 For a complete list.
NUMBER & PARAMETER LIST	A user-configurable list of data types to be recorded in any given channel. See APPENDIX A-5 for a list of available parameters	1 – DETMES	See Appendix A-5 For a complete list.
STARTING DATE	The starting date when a channel starts collecting data	01-JAN-03	Any actual date in the past or future.
SAMPLE PERIOD	The amount of time between each data point that is averaged into one mean reported every REPORT PERIOD.	000:01:00	000:00:01 to 366:23:59 (Days:Hours:Minutes)
REPORT PERIOD	The amount of time between each channel data point.	000:01:00	000:00:01 to 366:23:59 (Days:Hours:Minutes)
NUMBER OF RECORDS	The number of reports that will be stored in the data file. Once the specified limit has been exceeded, the oldest data are over-written to make space for new data.	100	1 to 1 million, limited by available storage space.
RS-232 REPORT	Enables the analyzer to automatically report channel values to the RS-232 ports.	OFF	OFF or ON
CHANNEL ENABLED	Enables or disables the channel. Provides a convenient means to temporarily disable a data channel.	ON	OFF or ON
CAL HOLD OFF	Disables sampling of data parameters while instrument is in calibration mode. When enabled here – there is also a length of the DAS HOLD OFF after calibration mode, which is set in the VARS menu.	OFF	OFF or ON (Section 6.7.2.11.)

6.7.1.2. DAS Parameters

Data parameters are types of data that may be measured and stored by the DAS. For each Teledyne Instruments analyzer model, the list of available data parameters is different, fully defined and not customizable. Appendix A-5 lists firmware specific data parameters for the analyzer. DAS parameters include things like CO₂ concentration measurements, temperatures of the various heaters placed around the analyzer, pressures and flows of the pneumatic subsystem and other diagnostic measurements as well as calibration data such as slope and offset.

Most data parameters have associated measurement units, such as mV, ppb, cm³/min, etc., although some parameters have no units. With the exception of concentration readings, none of these units of measure can be changed. To change the units of measure for concentration readings See Section 6.8.6.

Note

DAS does not keep track of the unit of each concentration value and DAS data files may contain concentrations in multiple units if the unit was changed during data acquisition.

Each data parameter has user-configurable functions that define how the data are recorded:

Table 6-8: DAS Data Parameter Functions

FUNCTION	EFFECT
PARAMETER	Instrument-specific parameter name.
SAMPLE MODE	INST: Records instantaneous reading. AVG: Records average reading during reporting interval. MIN: Records minimum (instantaneous) reading during reporting interval. MAX: Records maximum (instantaneous) reading during reporting interval. SDEV: Records the standard deviation of the data points recorded during the reporting interval.
PRECISION	Decimal precision of parameter value (0-4).
STORE NUM. SAMPLES	OFF: stores only the average (default). ON: stores the average and the number of samples in each average for a parameter. This property is only useful when the AVG sample mode is used. Note that the number of samples is the same for all parameters in one channel and needs to be specified only for one of the parameters in that channel.

Users can specify up to 50 parameters per data channel (the GFC 7000T provides about 30 parameters). However, the number of parameters and channels is ultimately limited by available memory.

6.7.1.3. DAS Triggering Events

Triggering events define when and how the DAS records a measurement of any given data channel. Triggering events are firmware-specific and a complete list of Triggers for this model analyzer can be found in Appendix A-5. The most commonly used triggering events are:

- **ATIMER:** Sampling at regular intervals specified by an automatic timer. Most trending information is usually stored at such regular intervals, which can be instantaneous or averaged.
- **EXITZR, EXITSP, SLPCHG** (exit zero, exit span, slope change): Sampling at the end of (irregularly occurring) calibrations or when the response slope changes. These triggering events create instantaneous data points, e.g., for the new slope and offset (concentration response) values at the end of a calibration. Zero and slope values are valuable to monitor response drift and to document when the instrument was calibrated.
- **WARNINGS:** Some data may be useful when stored if one of several warning messages appears such as **WTEMPW** (GFC wheel temperature warning) or **PPRESW** (purge pressure warning). This is helpful for trouble-shooting by monitoring when a particular warning occurred.

6.7.2. Default DAS Channels

A set of default Data Channels has been included in the analyzer's software for logging CO₂ concentration and certain predictive diagnostic data. These default channels include but are not limited to:

CONC: Samples CO₂ concentration at one minute intervals and stores an average every hour with a time and date stamp. Readings during calibration and calibration hold off are not included in the data. By default, the last 800 hourly averages are stored.

PNUMTC: Collects sample flow and sample pressure data at five minute intervals and stores an average once a day with a time and date stamp. This data is useful for monitoring the condition of the pump and critical flow orifice (sample flow) and the sample filter (clogging indicated by a drop in sample pressure) over time to predict when maintenance will be required. The last 360 daily averages (about 1 year) are stored.

CALDAT: Logs new slope and offset every time a zero or span calibration is performed. This Data Channel also records the instrument readings just prior to performing a calibration. This information is useful for performing predictive diagnostics as part of a regular maintenance schedule (See Section 9.1).

STBZRO: Logs the concentration stability, the electronic output of the IR detector of the most recent measure phase and the measure/reference ratio every time the instrument exits the zero calibration mode. Data from the last 200 zero calibrations is stored. A time and date stamp is recorded for every data point logged. This information is useful for performing predictive diagnostics as part of a regular maintenance schedule (See Section 9.1).

STBSPN: Logs the electronic output of the IR detector of the most recent measure phase and the measure/reference ratio every time the instrument exits span calibration mode. Data from the last 200 zero calibrations is stored. A time and date stamp is recorded for every data point logged. This information is useful for performing predictive diagnostics as part of a regular maintenance schedule (See Section 9.1).

TEMP: Samples the analyzer's bench temperature, box temperature and PHT cooler drive voltage every five minutes and records an average once every six hours. Data from the last 400 averaging periods is recorded. A time and date stamp is recorded for every data point logged. This information is useful for performing predictive diagnostics as part of a regular maintenance schedule (See Section 9.1).

Note

The CALDAT, STBZRO and STBSPN channels collect data based on events (e.g. a calibration operation) rather than a timed interval. This does not represent any specific length of time since it is dependent on how often calibrations are performed.

Triggering Events and Data Parameters/Functions for these default channels are:

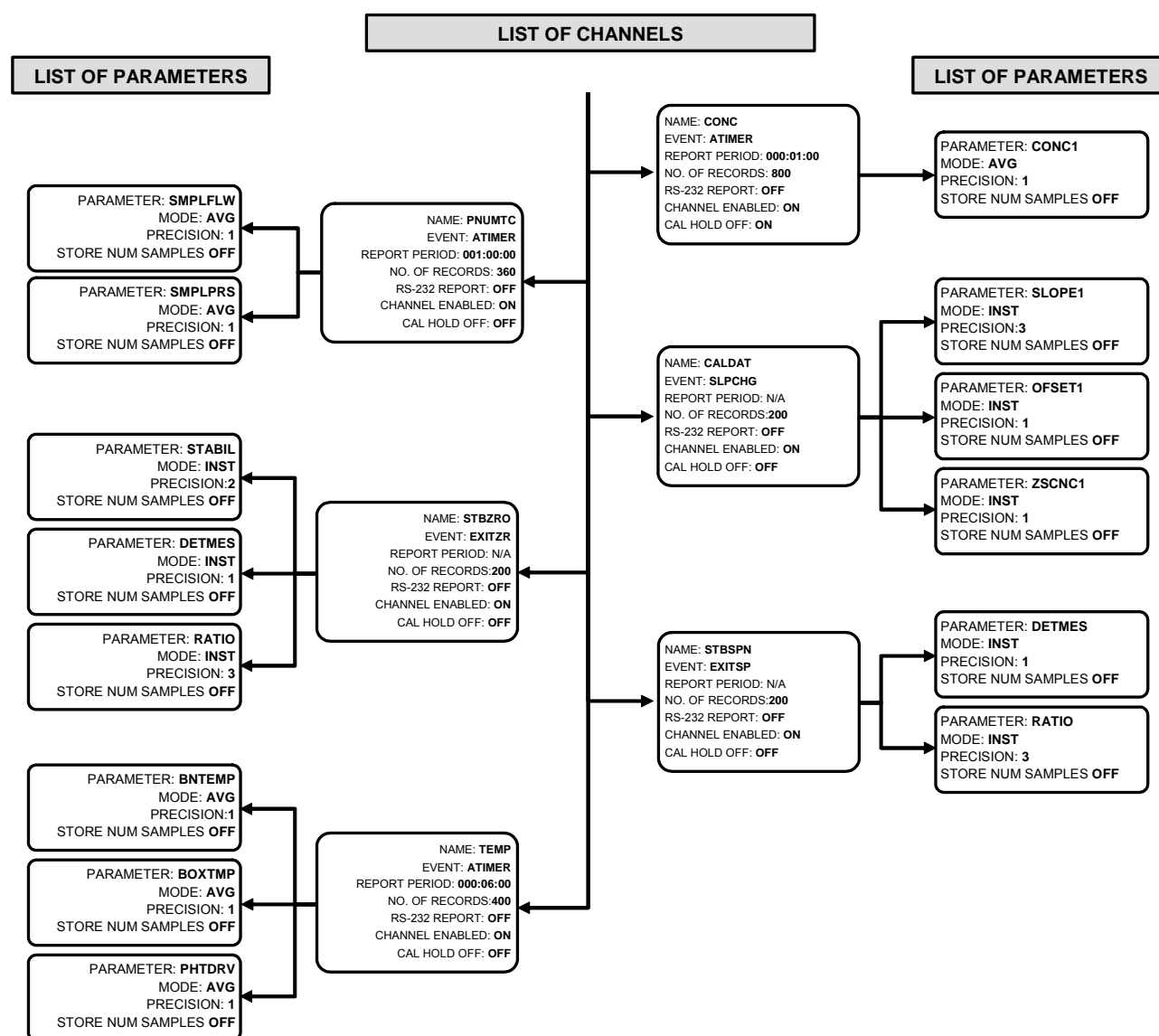

Figure 6-4: Default DAS Channels Setup

These default Data Channels can be used as they are, or they can be customized from the front panel to fit a specific application. They can also be deleted to make room for custom user-programmed Data Channels.

Appendix A-5 lists the firmware-specific DAS configuration in plain-text format. This text file can either be loaded into APICOM and then modified and uploaded to the instrument or can be copied and pasted into a terminal program to be sent to the analyzer.

NOTE

Sending an DAS configuration to the analyzer through its COM ports will replace the existing configuration and will delete all stored data. Back up any existing data and the DAS configuration before uploading new settings.

These default Data Channels can be used as they are, or they can be customized from the front panel to fit a specific application. They can also be deleted to make room for custom user-programmed Data Channels.

Appendix A-5 lists the firmware-specific DAS configuration in plain-text format. This text file can either be loaded into APICOM and then modified and uploaded to the instrument or can be copied and pasted into a terminal program to be sent to the analyzer.

NOTE

Sending an DAS configuration to the analyzer through its COM ports will replace the existing configuration and will delete all stored data. Back up any existing data and the DAS configuration before uploading new settings.

6.7.2.1. DAS Configuration Limits

The number of DAS objects are limited by the instrument's finite storage capacity. For information regarding the maximum number of channels, parameters, and records and how to calculate the file size for each data channel, refer to the DAS manual downloadable from the TAI website at <http://www.teledyne-api.com/manuals/>.

6.7.2.2. Viewing DAS Data and Settings

DAS data and settings can be viewed on the front panel through the following touchscreen buttons sequence.

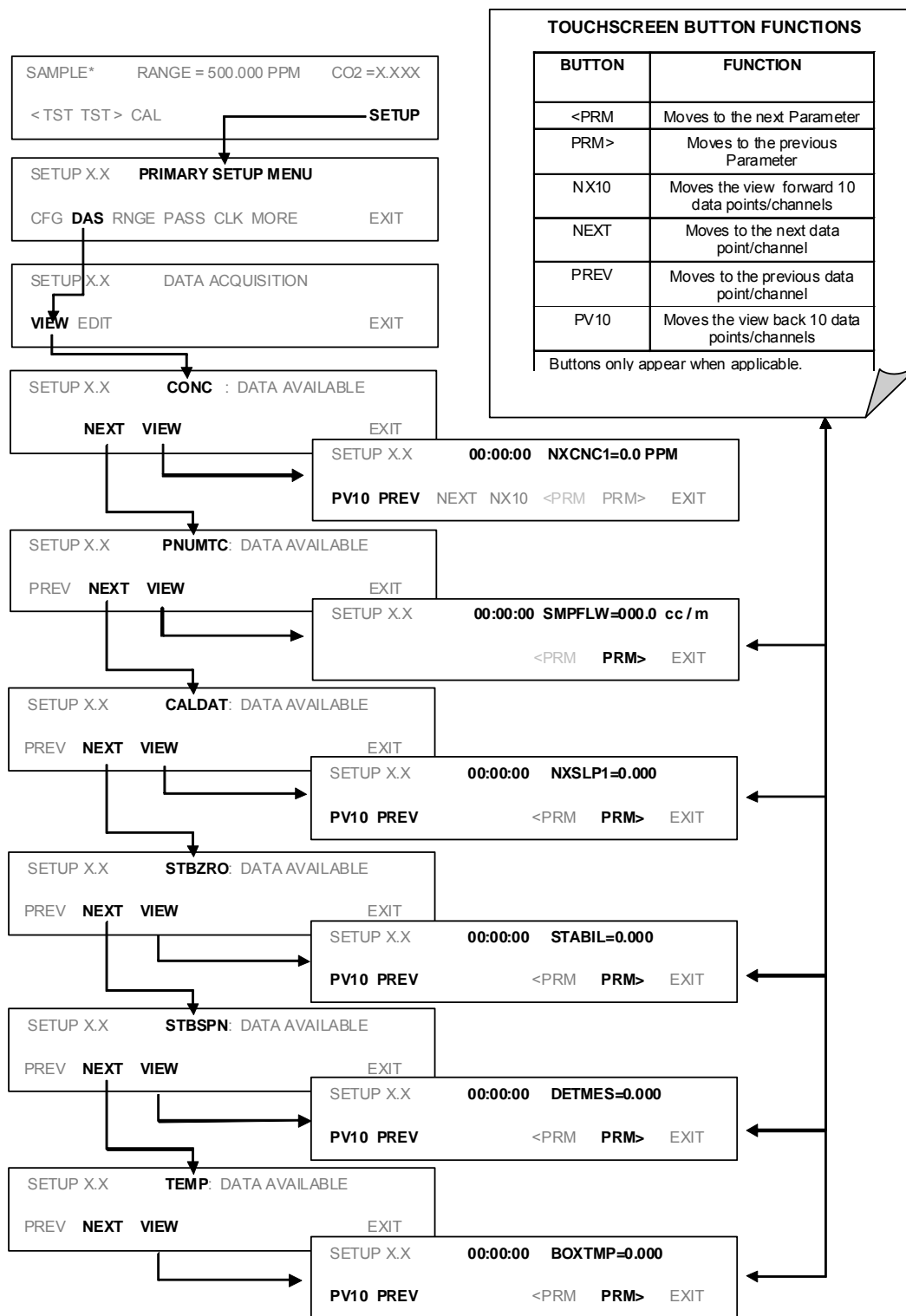

6.7.2.3. Editing DAS Data Channels

DAS configuration is most conveniently done through the APICOM remote control program. The following list of key strokes shows how to edit using the front panel.

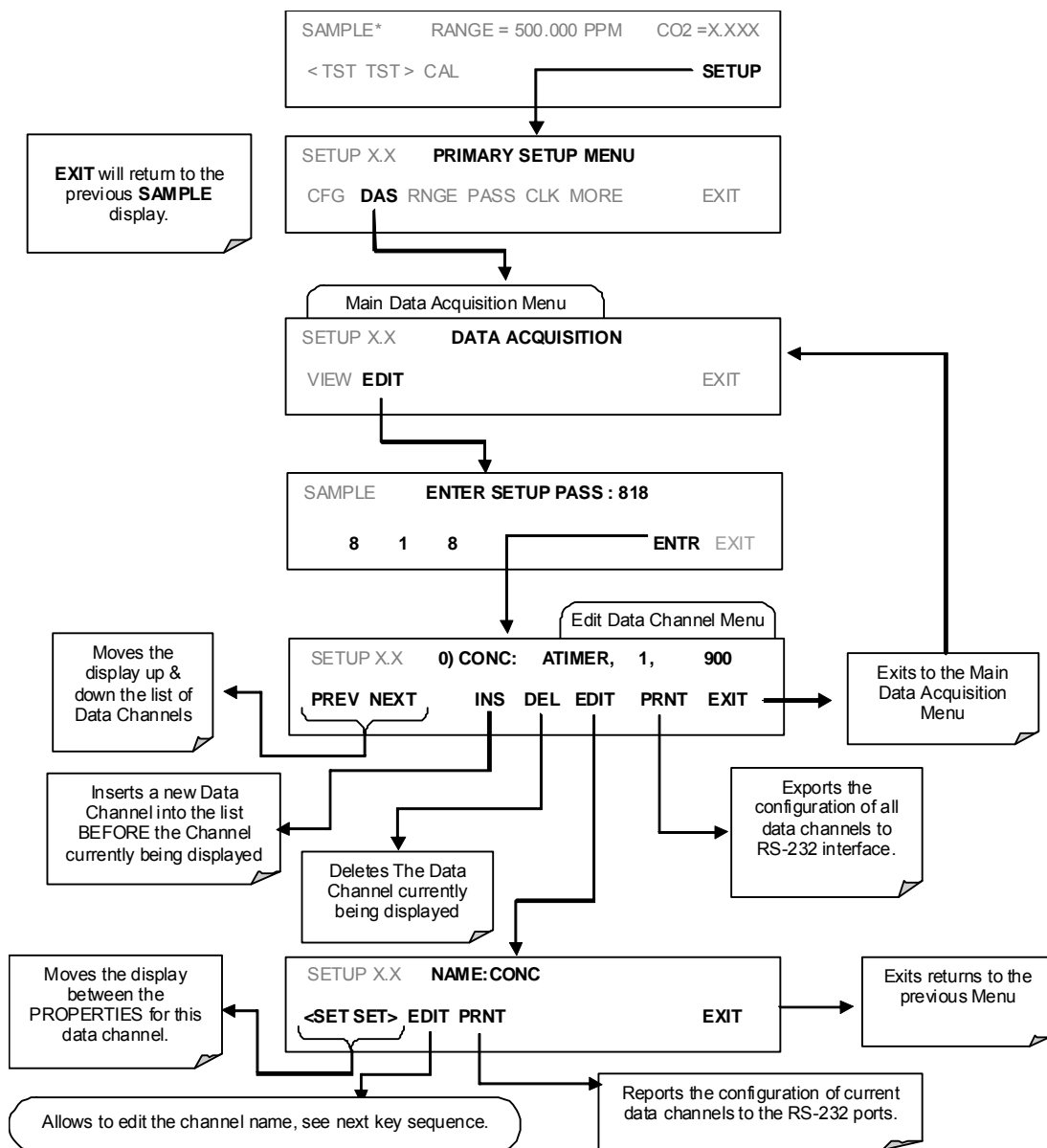

When editing the data channels, the top line of the display indicates some of the configuration parameters. For example, the display line:

0) CONC: ATIMER, 4, 800

translates to the following configuration:

Channel No.: 0

NAME: CONC

TRIGGER EVENT: ATIMER

PARAMETERS: Four parameters are included in this channel

EVENT: This channel is set up to record 800 data points.

To edit the name of a data channel, follow the above touchscreen button sequence and then press:

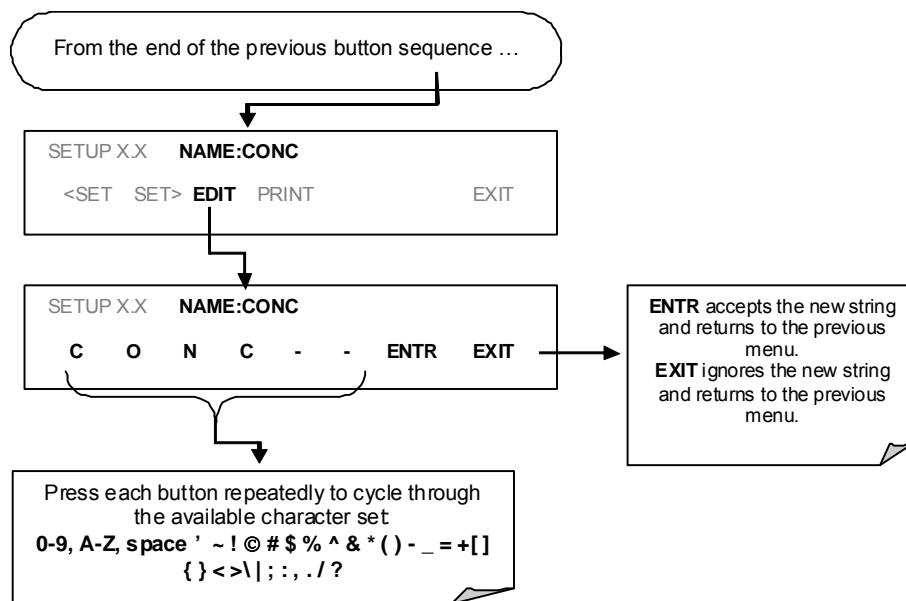

6.7.2.4. Trigger Events

To edit the list of data parameters associated with a specific data channel, press:

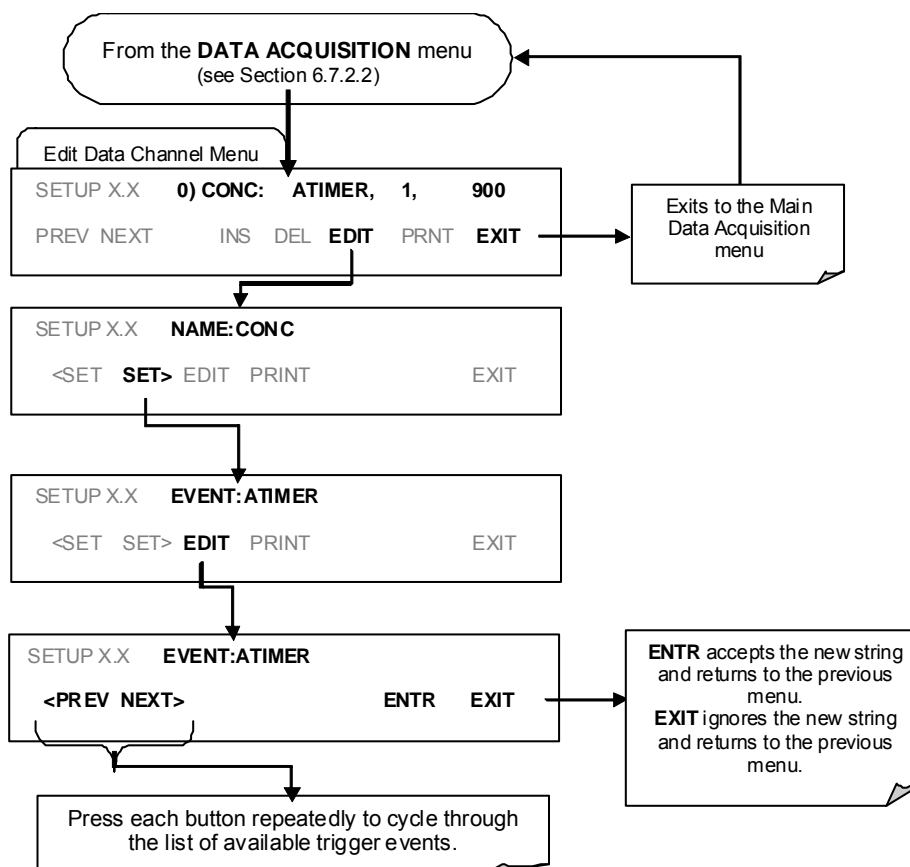

6.7.2.5. Editing DAS Parameters

Data channels can be edited individually from the front panel without affecting other data channels. However, when editing a data channel, such as during adding, deleting or editing parameters, all data for that particular channel will be lost, because the DAS can store only data of one format (number of parameter columns etc.) for any given channel. In addition, an DAS configuration can only be uploaded remotely as an entire set of channels. Hence, remote update of the DAS will always delete all current channels and stored data.

To modify, add or delete a parameter, follow the instruction shown in Section 6.7.2.2 then press:

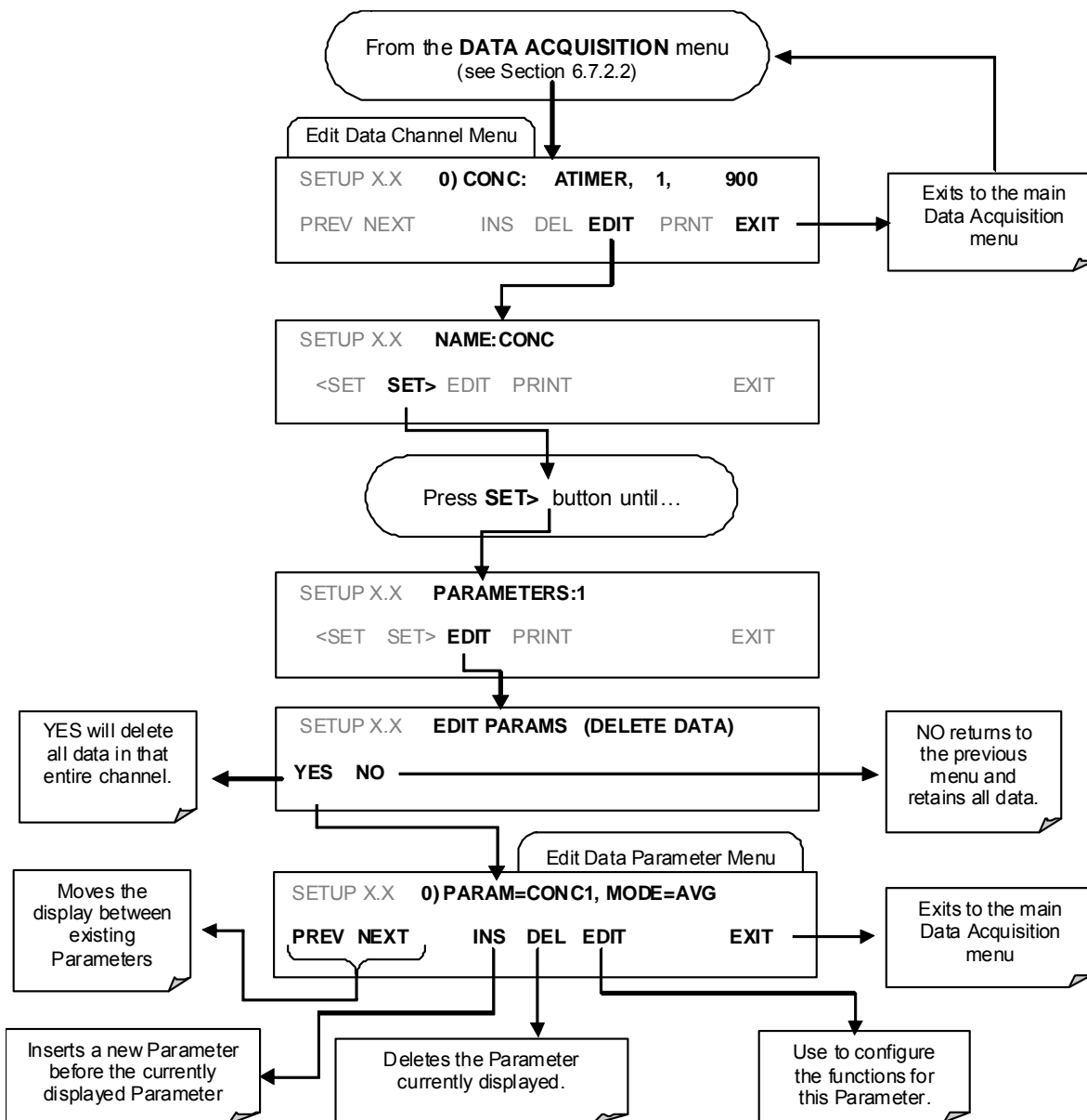

To configure a specific data parameter, press:

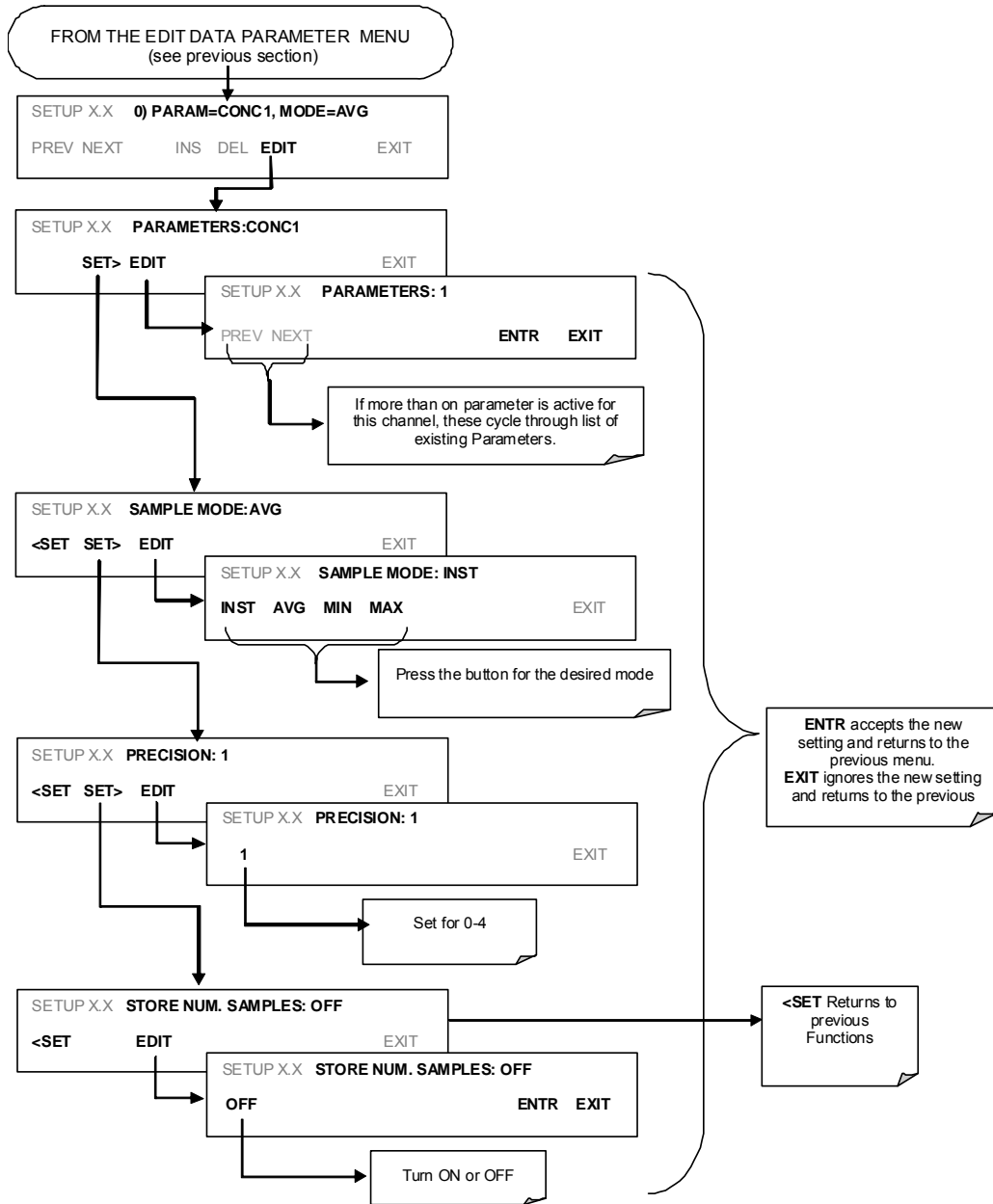

6.7.2.6. Sample Period and Report Period

The DAS defines two principal time periods by which sample readings are taken and permanently recorded:

- **SAMPLE PERIOD:** Determines how often DAS temporarily records a sample reading of the parameter in volatile memory. The **SAMPLE PERIOD** is set to one minute by default and generally cannot be accessed from the standard DAS front panel menu, but is available via the instruments communication ports by using APICOM or the analyzer's standard serial data protocol.

SAMPLE PERIOD is only used when the DAS parameter's sample mode is set for **AVG**, **MIN** or **MAX**.

- **REPORT PERIOD:** Sets how often the sample readings stored in volatile memory are processed, (e.g. average, minimum or maximum are calculated) and the results stored permanently in the instruments Disk-on-Chip as well as transmitted via the analyzer's communication ports. The **REPORT PERIOD** may be set from the front panel.

If the **INST** sample mode is selected the instrument stores and reports an instantaneous reading of the selected parameter at the end of the chosen **REPORT PERIOD**

In **AVG**, **MIN** or **MAX** sample modes, the settings for the **SAMPLE PERIOD** and the **REPORT PERIOD** determine the number of data points used each time the average, minimum or maximum is calculated, stored and reported to the com ports. The actual sample readings are not stored past the end of the of the chosen **REPORT PERIOD**.

Also, the **SAMPLE PERIOD** and **REPORT PERIOD** intervals are synchronized to the beginning and end of the appropriate interval of the instruments internal clock.

- If **SAMPLE PERIOD** were set for one minute the first reading would occur at the beginning of the next full minute according to the instrument's internal clock.
- If the **REPORT PERIOD** were set for of one hour the first report activity would occur at the beginning of the next full hour according to the instrument's internal clock.

EXAMPLE: Given the above settings, if DAS were activated at 7:57:35 the first sample would occur at 7:58 and the first report would be calculated at 8:00 consisting of data points for 7:58, 7:59 and 8:00.

During the next hour (from 8:01 to 9:00) the instrument will take a sample reading every minute and include 60 sample readings.

When the **STORE NUM. SAMPLES** feature is turned on the instrument will also store how many sample readings were used for the **AVG**, **MIN** or **MAX** calculation but not the readings themselves.

REPORT PERIODS IN PROGRESS WHEN INSTRUMENT IS POWERED OFF

If the instrument is powered off in the middle of a **REPORT PERIOD**, the samples accumulated so far during that period are lost. Once the instrument is turned back on, the DAS restarts taking samples and temporarily them in volatile memory as part of the **REPORT PERIOD** currently active at the time of restart. At the end of this **REPORT PERIOD** only the sample readings taken since the instrument was turned back on will be included in any **AVG**, **MIN** or **MAX** calculation. Also, the **STORE NUM. SAMPLES** feature will report the number of sample readings taken since the instrument was restarted.

To define the **REPORT PERIOD**, follow the instruction shown in Section 6.7.2.2 then press:

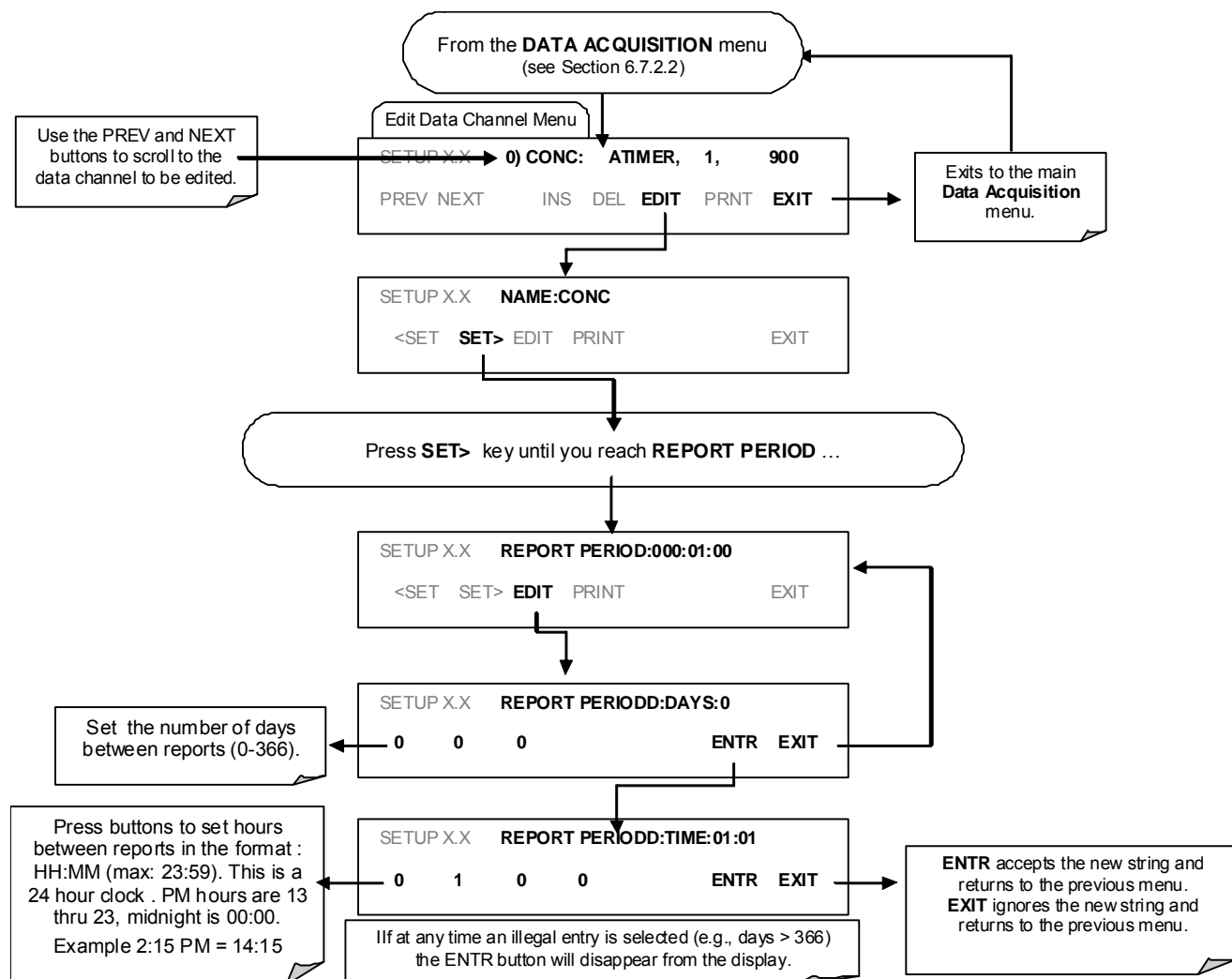

6.7.2.7. Number of Records

The number of data records in the GFC 7000T is limited to about a cumulative one million data points in all channels (one megabyte of space on the disk-on-chip). However, the actual number of records is also limited by the total number of parameters and channels and other settings in the DAS configuration. Every additional data channel, parameter, number of samples setting etc. and will reduce the maximum amount of data points somewhat. In general, however, the maximum data capacity is divided amongst all channels (max: 20) and parameters (max: 50 per channel).

The DAS will check the amount of available data space and prevent the user from specifying too many records at any given point. If, for example, the DAS memory space can accommodate 375 more data records, the ENTR key will disappear when trying to specify more than that number of records. This check for memory space may also make an upload of an DAS configuration with APICOM or a Terminal program fail, if the combined number of records would be exceeded. In this case, it is suggested to either try from the front panel what the maximum number of records can be or use trial-and-error in designing the DAS script or calculate the number of records using the DAS or APICOM manuals. To set the number of records for one channel from the front panel, press SETUP-DAS-EDIT-ENTR and the following touchscreen button sequence.

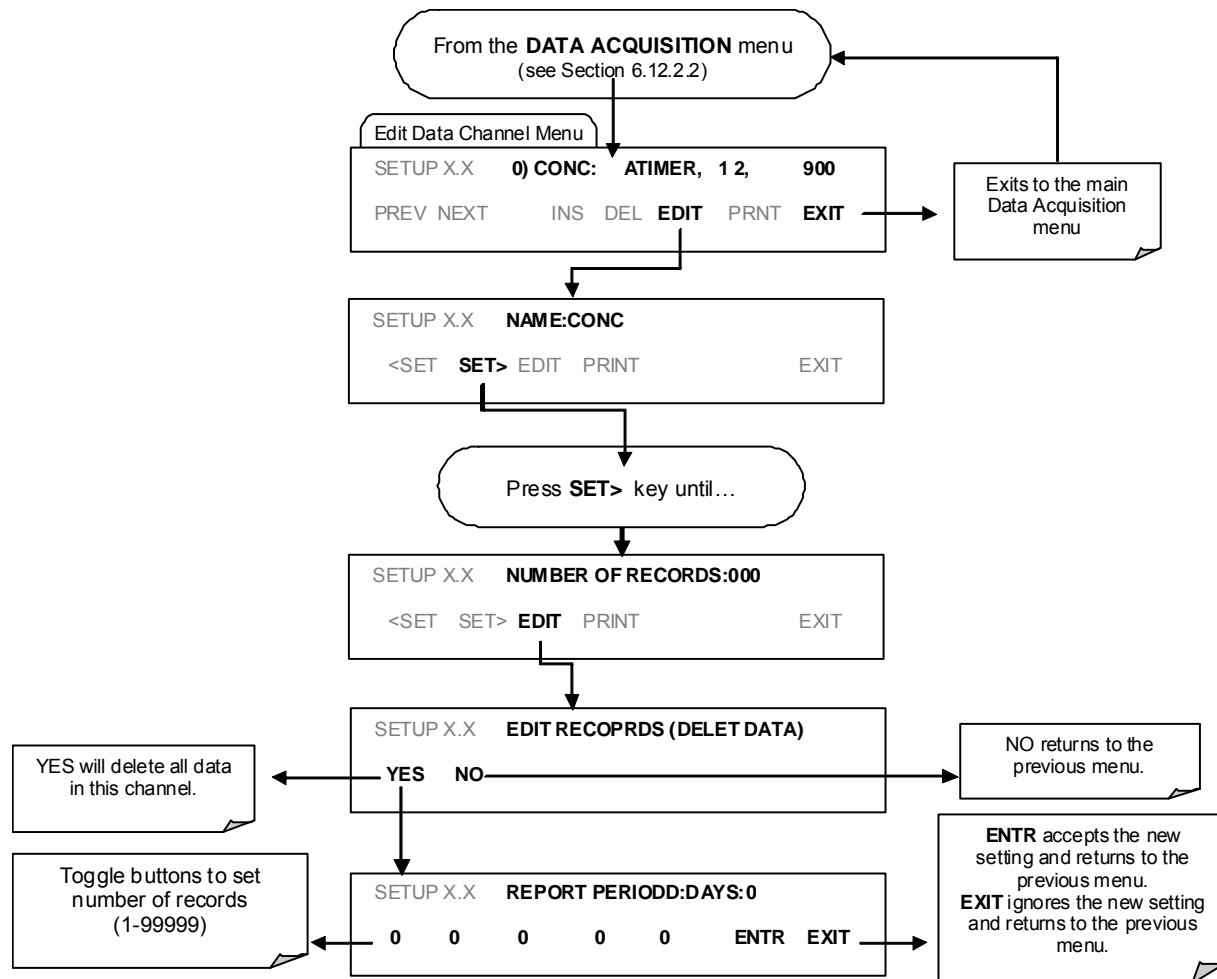

6.7.2.8. RS-232 Report Function

The GFC 700T DAS can automatically report data to the communications ports, where they can be captured with a terminal emulation program or simply viewed by the user.

To enable automatic COM port reporting, follow the instruction shown in Section 6.7.2.2 then press:

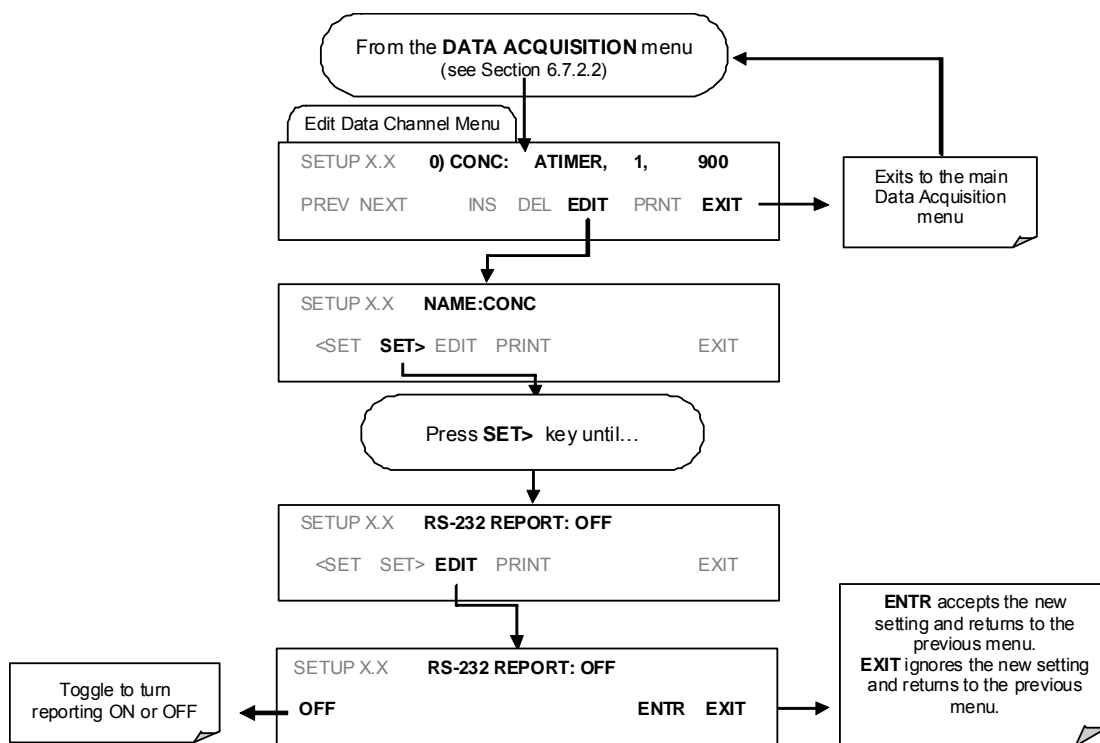

6.7.2.9. Compact Report

When enabled, this option avoids unnecessary line breaks on all RS-232 reports. Instead of reporting each parameter in one channel on a separate line, up to five parameters are reported in one line.

6.7.2.10. Starting Date

This option allows to specify a starting date for any given channel in case the user wants to start data acquisition only after a certain time and date. If the **Starting Date** is in the past, the DAS ignores this setting.

6.7.2.11. Disabling/Enabling Data Channels

Data channels can be temporarily disabled, which can reduce the read/write wear on the disk-on-chip. The ALL_01 channel of the GFC 7000T, for example, is disabled by default.

To disable a data channel, follow the instruction shown in Section 6.7.2.2 then press:

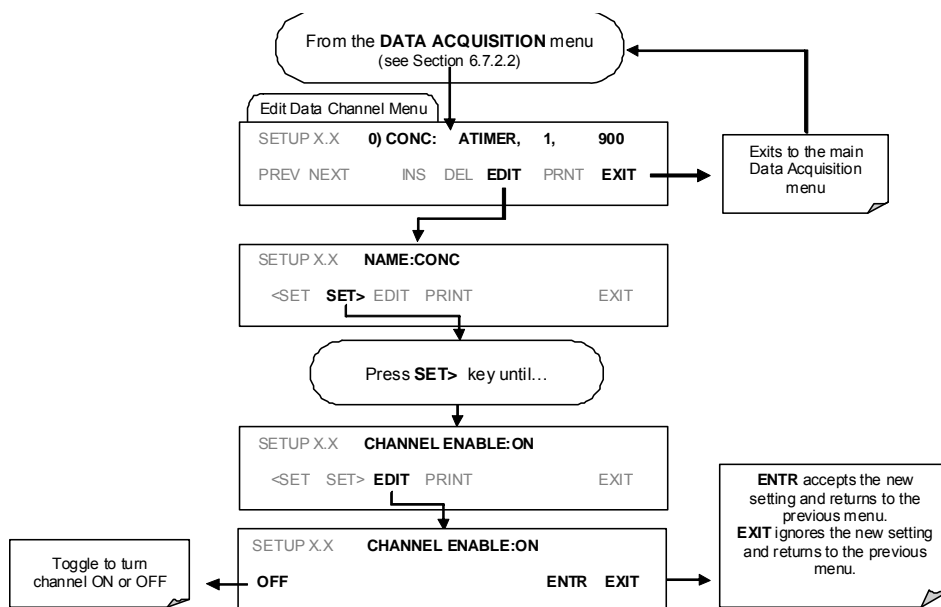

6.7.2.12. HOLDOFF Feature

The DAS HOLDOFF feature allows to prevent data collection during calibrations and during the **DAS_HOLDOFF** period enabled and specified in the VARS (Section 6.12). To enable or disable the HOLDOFF, follow the instruction shown in Section 6.7.2.2 then press:

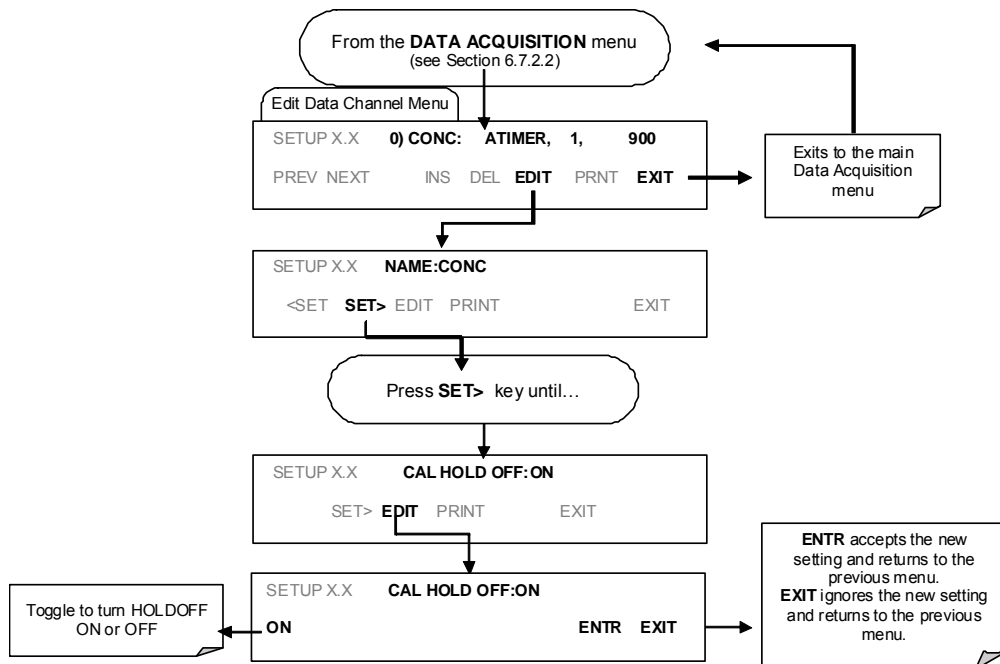

6.7.3. Remote DAS Configuration

Editing channels, parameters and triggering events as described in this can be performed via the APICOM remote control program using the graphic interface shown in Figure 6-5. Refer to Section 6.15 for details on remote access to the GFC 7000T analyzer.

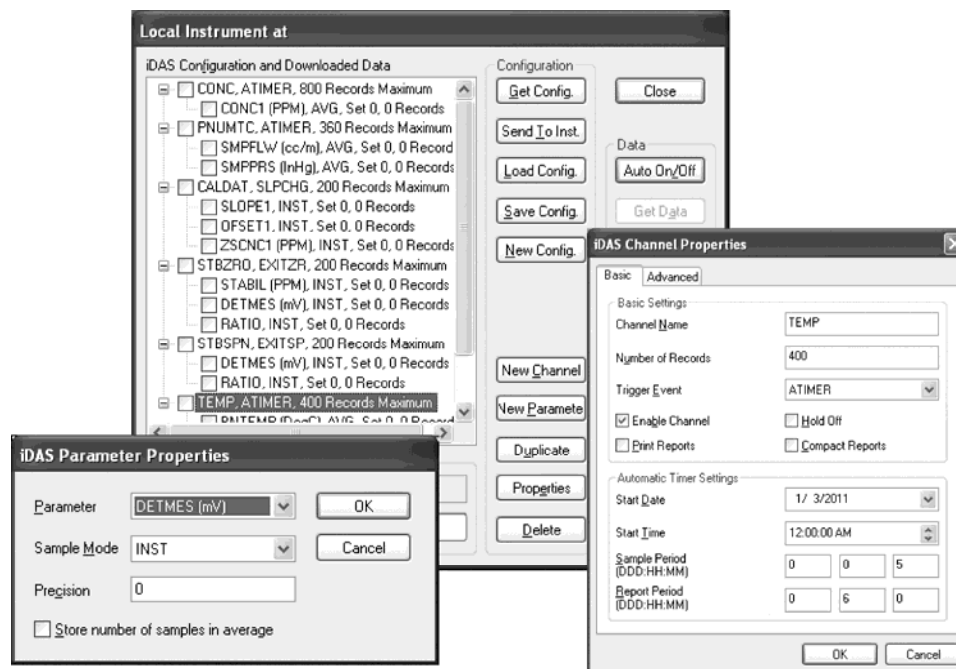

Figure 6-5: APICOM User Interface for DAS Configuration

Once a DAS configuration is edited (which can be done offline and without interrupting DAS data collection), it is conveniently uploaded to the instrument and can be stored on a computer for later review, alteration or documentation and archival. Refer to the APICOM manual for details on these procedures. The APICOM user manual (Teledyne Instruments part number 039450000) is included in the APICOM installation file, which can be downloaded at <http://www.teledyne-api.com/software/apicom/>. It is recommended that you start by downloading the default DAS configuration, getting familiar with its command structure and syntax conventions, and then altering a copy of the original file offline before uploading the new configuration.

CAUTION

Whereas the editing, adding and deleting of DAS channels and parameters of one channel through the front-panel touchscreen can be done without affecting the other channels, uploading an DAS configuration script to the analyzer through its communication ports will erase all data, parameters and channels by replacing them with the new DAS configuration. Backup of data and the original DAS configuration is advised before attempting any DAS changes.

6.8. SETUP → RNGE: Analog Output Reporting Range Configuration

The analyzer has three active analog output signals, accessible through a connector on the rear panel.

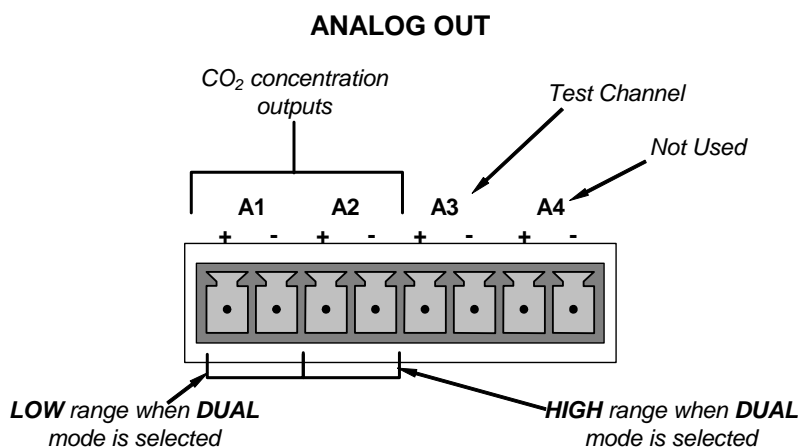

Figure 6-6: Analog Output Connector Pin Out

All three outputs can be configured either at the factory or by the user for full scale outputs of 0.1 VDC, 1VDC, 5VDC or 10VDC. Additionally **A1** and **A2** may be equipped with optional 0-20 mADC current loop drivers and configured for any current output within that range (e.g. 0-20, 2-20, 4-20, etc.). The user may also adjust the signal level and scaling of the actual output voltage or current to match the input requirements of the recorder or data logger (See Section 6.13.4).

The **A1** and **A2** channels output a signal that is proportional to the CO₂ concentration of the sample gas. Several modes are available which allow them to operate independently or be slaved together (See Section 6.7). The user may also select between a variety of reporting range spans (See Sections 6.8.3, 6.8.4 and 6.8.5).

EXAMPLE:

A1 OUTPUT: Output Signal = 0-5 VDC representing 0-1000 ppm concentration values

A2 OUTPUT: Output Signal = 0 – 10 VDC representing 0-500 ppm concentration values.

Output **A3** is only active if the O₂ sensor option is installed. In this case a signal representing the currently measured O₂ concentration is output on this channel.

The output, labeled **A4** is special. It can be set by the user (See Section 6.13.9) to output several of the test functions accessible through the <TST TST> keys of the units sample display.

6.8.1. Physical Range versus Analog Output Reporting Ranges

Functionally, the Gas Filter Correlation CO₂ Analyzer has one hardware Physical Range that is capable of determining CO₂ concentrations between 50 ppm and 2,000 ppm. This architecture improves reliability and accuracy by avoiding the need for extra, switchable, gain-amplification circuitry. Once properly calibrated, the analyzer's front panel will accurately report concentrations along the entire span of its 50 ppm and 2,000 ppm physical range.

Because, most applications use only a small part of the analyzer's physical range, the width of the Model GFC 7000T's physical range can create data resolution problems for most analog recording devices. For example, in an application where the expected concentration of CO₂ is typically less than 500 ppm, the full scale of expected values is only 25% of the instrument's 2,000 ppm physical range. Unmodified, the corresponding output signal would also be recorded across only 25% of the range of the recording device.

The GFC 7000T solves this problem by allowing the user to select a scaled reporting range for the analog outputs that only includes that portion of the physical range relevant to the specific application. Only the reporting range of the analog outputs is scaled, the physical range of the analyzer and the readings displayed on the front panel remain unaltered.

6.8.2. Reporting Range Modes

The GFC 7000T provides three analog output range modes to choose from.

- Single range (**SNGL**) mode sets a single maximum range for the analog output. If single range is selected (See Section 6.78.3) both outputs are slaved together and will represent the same measurement span (e.g. 0-50 ppm), however their electronic signal levels may be configured for different ranges (e.g. 0-10 VDC vs. 0-.1 VDC – See Section 6.9.4.1).

Dual range (**DUAL**) allows the A1 and A2 outputs to be configured with different measurement spans (See Section 6.8.4) as well as separate electronic signal levels (See Section 6.9.4.1).
- Auto range (**AUTO**) mode gives the analyzer to ability to output data via a low range and high range. When this mode is selected (See Section 6.8.5) the GFC 7000T will automatically switch between the two ranges dynamically as the concentration value fluctuates.

Range status is also output via the external digital I/O status outputs (See Section 6.15.1.1).

To select the Analog Output Range Type press:

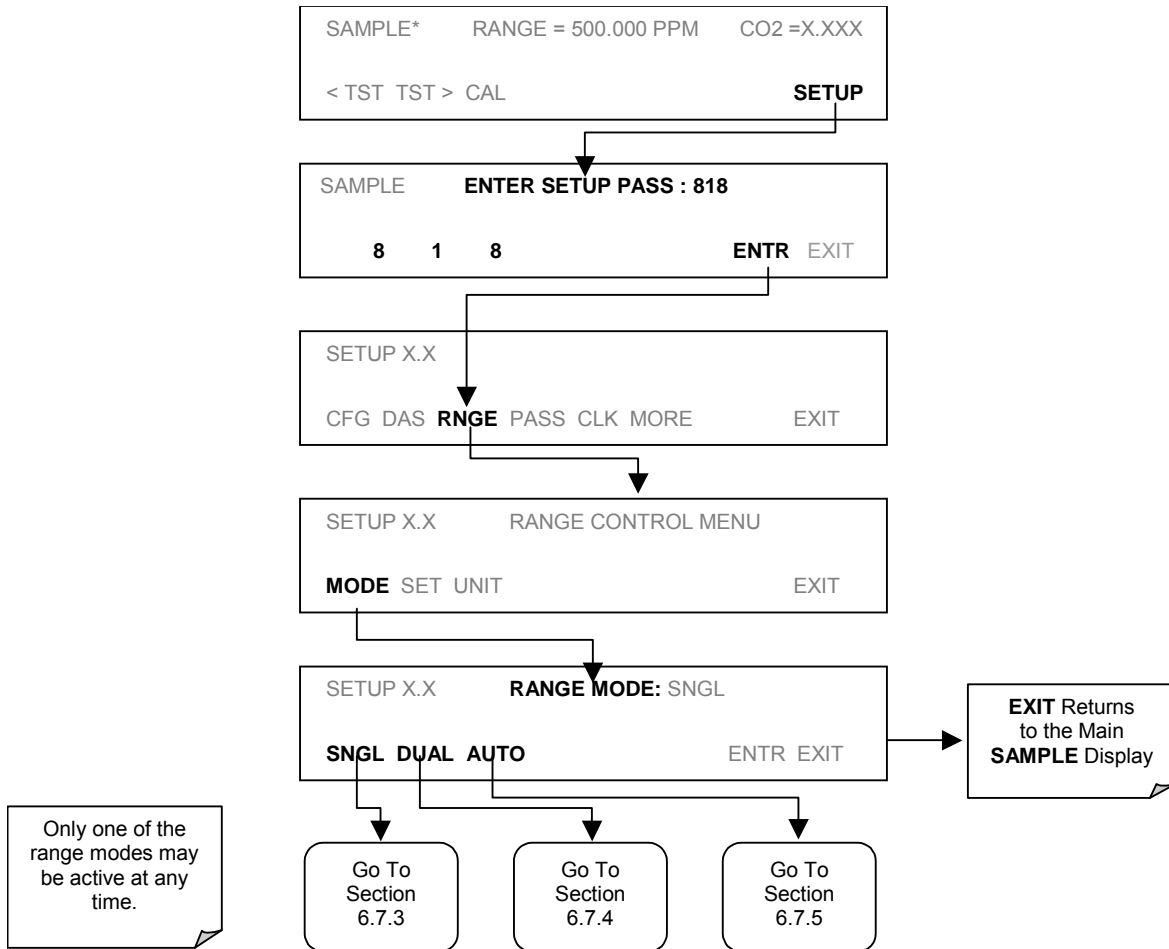

NOTE

Upper span limit setting for the individual range modes are shared. Resetting the span limit in one mode also resets the span limit for the corresponding range in the other modes as follows:

SNGL		DUAL		AUTO
Range	↔	Range1	↔	Low Range
		Range2	↔	High Range

6.8.3. Single Range Mode (SNGL)

This is the default reporting range mode for the analyzer. In single range mode both **A1** and **A2** are set to the same reporting range. This reporting range can be any value between 50 ppm and 2 000 ppm.

While the two outputs always have the same reporting range, the span, signal offset and scaling of their electronic signals may be configured for differently (e.g., **A1** = 0-10 V; **A2** = 0-0.1 V). See Section 6.13.4 for instructions on adjusting these parameters.

To select **SNGL** range mode and to set the upper limit of the range, press:

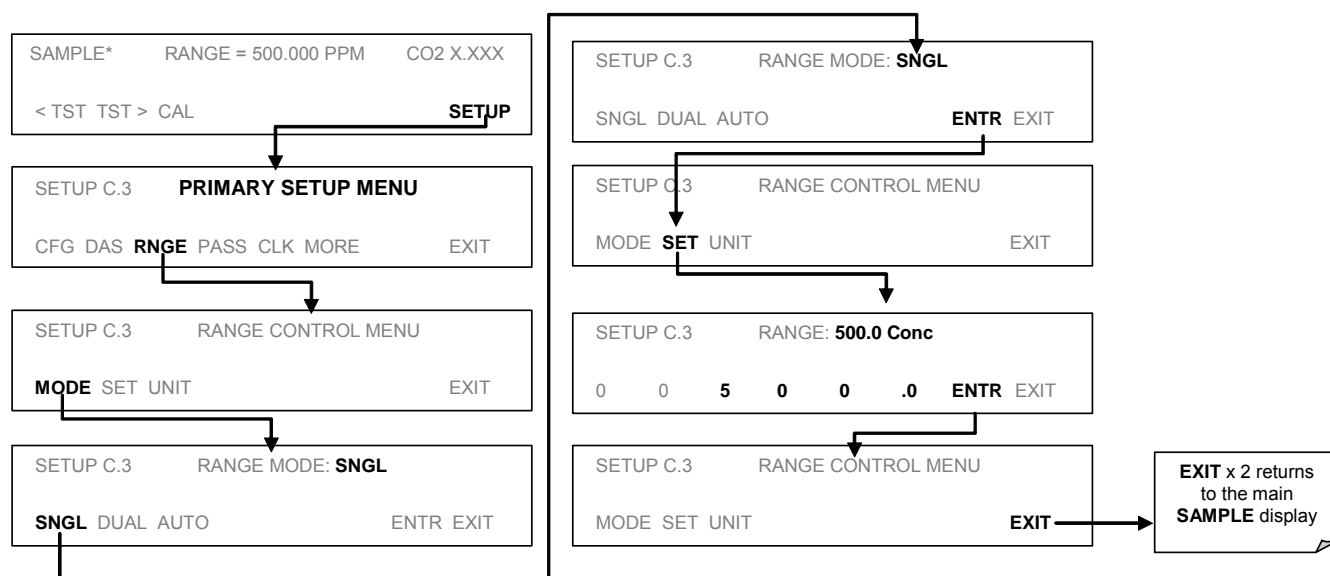

6.8.4. Dual Range Mode (DUAL)

Selecting Dual Range mode allows the **A1** and **A2** outputs to be configured with different reporting ranges. The analyzer software calls these two ranges low and high. The low range setting corresponds with the analog output labeled **A1** on the Rear Panel of the instrument. The high Range Setting corresponds with the **A2** output. While the software names these two ranges low and high, they do not have to be configured that way. For example: The low range can be set for a span of 0-1000 ppm while the high range is set for 0-500 ppm.

In **DUAL** range mode the **RANGE** test function displayed on the front panel will be replaced by two separate functions:

- **RANGE1**: The range setting for the **A1** output.
- **RANGE2**: The range setting for the **A2** output.

To set the ranges press following keystroke sequence

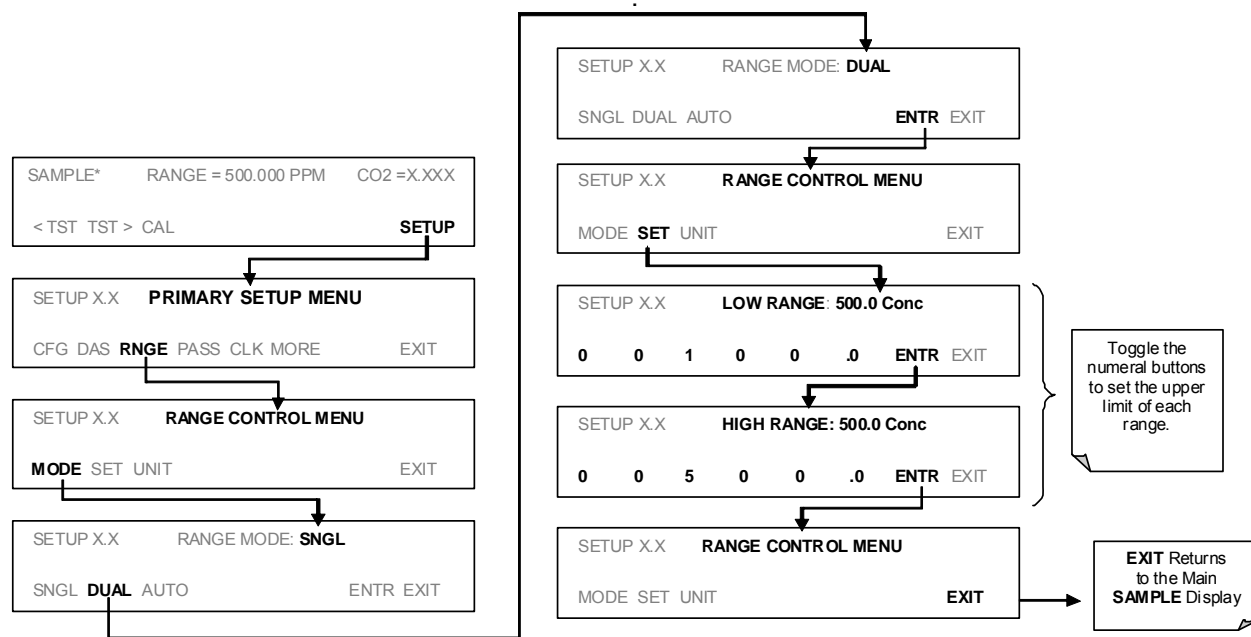

When the instrument's range mode is set to **DUAL** the concentration field in the upper right hand corner of the display alternates between displaying the low range value and the high range value. The concentration currently being displayed is identified as follows: C1 = Low (or **A1**) and C2 = High (or **A2**).

NOTE

In DUAL range mode the LOW and HIGH ranges have separate slopes and offsets for computing CO₂ concentration.

The two ranges must be independently calibrated.

6.8.5. Auto Range Mode (AUTO)

In **AUTO** range mode, the analyzer automatically switches the reporting range between two user-defined ranges (low and high). The unit will switch from low range to high range when the CO₂ concentration exceeds 98% of the low range span. The unit will return from high range back to low range once both the CO₂ concentration falls below 75% of the low range span.

In **AUTO** Range mode the instrument reports the same data in the same range on both the **A1** and **A2** outputs and automatically switches both outputs between ranges as described above. Also, the **RANGE** test function displayed on the front panel will automatically switch to show which range is in effect.

The high/low range status is also reported through the external, digital status outputs (Section 6.15.1.1).

To set individual ranges press the following keystroke sequence.

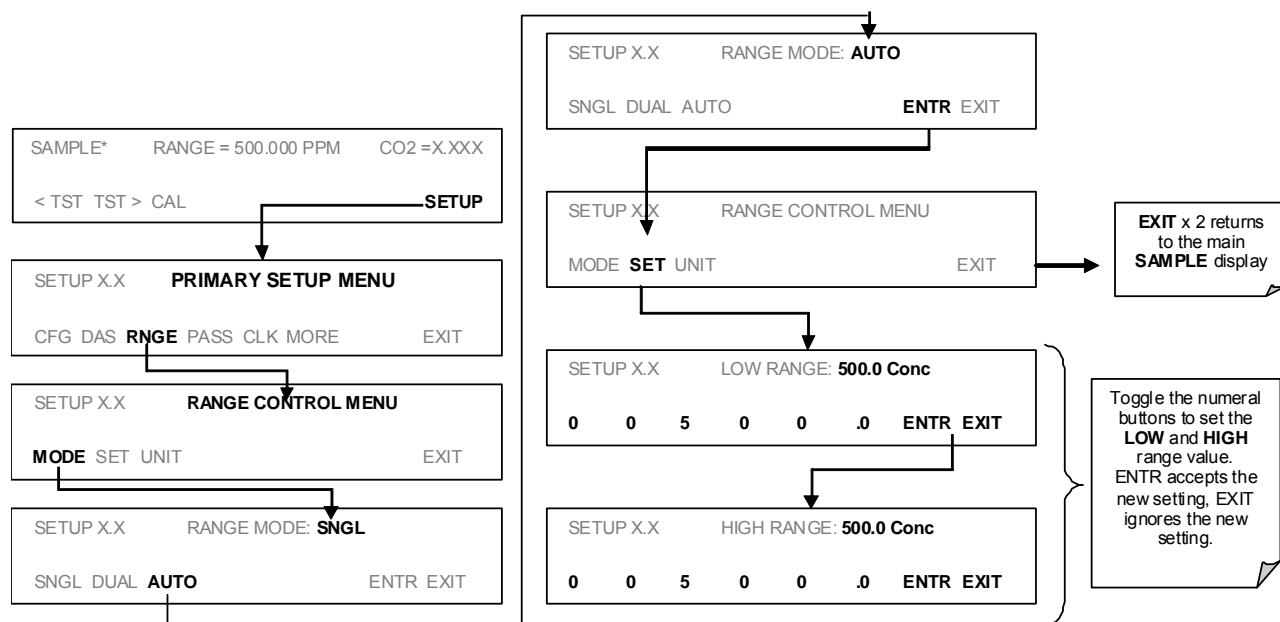

CAUTION

In AUTO range mode the LOW and HIGH ranges have separate slopes and offsets for computing CO₂ concentration.

The two ranges must be independently calibrated.

NOTE

Avoid accidentally setting the low range of the instrument with a higher span limit than the high range. This will cause the unit to stay in the low reporting range perpetually and defeat the function of the AUTO range mode.

6.8.6. Range Units

The GFC 7000T can display concentrations in parts per billion (10^9 mols per mol, **PPB**), parts per million (10^6 mols per mol, **PPM**), micrograms per cubic meter ($\mu\text{g}/\text{m}^3$, **UG**), milligrams per cubic meter (mg/m^3 , **MG**) or percent (volume CO_2 /volume sample gas, %). Changing units affects all of the display, analog outputs, COM port and DAS values for all reporting ranges regardless of the analyzer's range mode.

NOTE

Concentrations displayed in mg/m^3 and $\mu\text{g}/\text{m}^3$ use 0°C , 760 mmHg for Standard Temperature and Pressure (STP). Consult your local regulations for the STP used by your agency.

Conversion factors from volumetric to mass units are:
 $\text{CO}_2: \text{ppb} \times 1.96 = \mu\text{g}/\text{m}^3; \text{ppm} \times 1.96 = \text{mg}/\text{m}^3$

To change the concentration units:

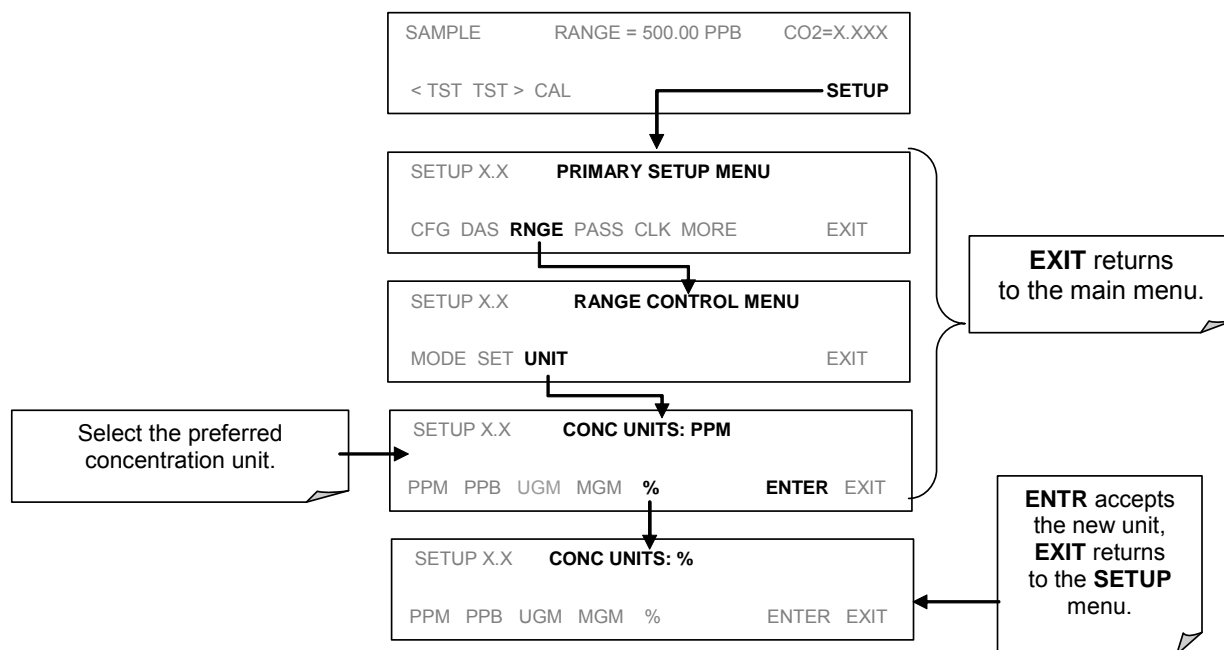

NOTE

Once the units of measurement have been changed the unit **MUST be recalibrated, as the "expected span values" previously in effect will no longer be valid. Simply entering new expected span values without running the entire calibration routine is not sufficient.**

6.8.7. Dilution Ratio

The dilution ratio is a software option that allows the user to compensate for any dilution of the sample gas before it enters the sample inlet. Using the dilution ratio option is a 4-step process:

1. Select reporting range units: Follow the procedure in Section 6.8.6.
2. Select the range: Use the procedures in Sections 6.8.2 – 6.8.5. Make sure that the **SPAN** value entered is the maximum expected concentration of the undiluted calibration gas and that the span gas is either supplied through the same dilution inlet system as the sample gas or has an appropriately lower actual concentration. For example, with a dilution set to 100, a 10 ppm gas can be used to calibrate a 1000 ppm sample gas if the span gas is not routed through the dilution system. On the other hand, if a 1000 ppm span gas is used, it needs to pass through the same dilution steps as the sample gas.
3. Set the dilution factor as a gain (e.g., a value of 20 means 20 parts diluting gas and 1 part of sample gas):

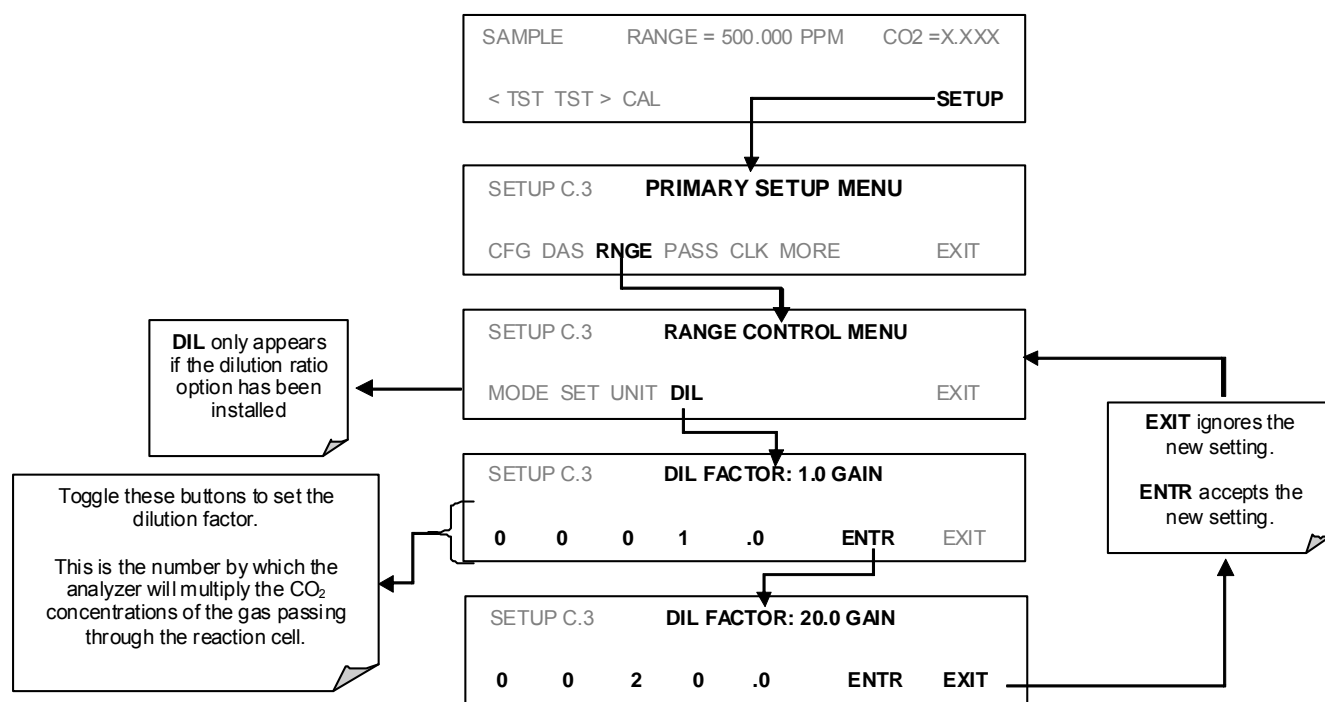

The analyzer multiplies the measured gas concentrations with this dilution factor and displays the result.

NOTE

Once the above settings have been entered, the instrument needs to be recalibrated using one of the methods discussed in Section 7.

6.9. SETUP → PASS: Password Feature

The GFC 7000T provides password protection of the calibration and setup functions to prevent unauthorized adjustments. When the passwords have been enabled in the **PASS** menu item, the system will prompt the user for a password anytime a password-protected function is requested.

There are three levels of password protection, which correspond to operator, maintenance, and configuration functions. Each level allows access to all of the functions in the previous level.

Table 6-9: Password Levels

PASSWORD	LEVEL	MENU ACCESS ALLOWED
No password	Operator	TEST, MSG, CLR
818	Maintenance	CAL, CALZ, CALS
929	Configuration	SETUP, VARS, DIAG

To enable or disable passwords, press the following keystroke sequence:

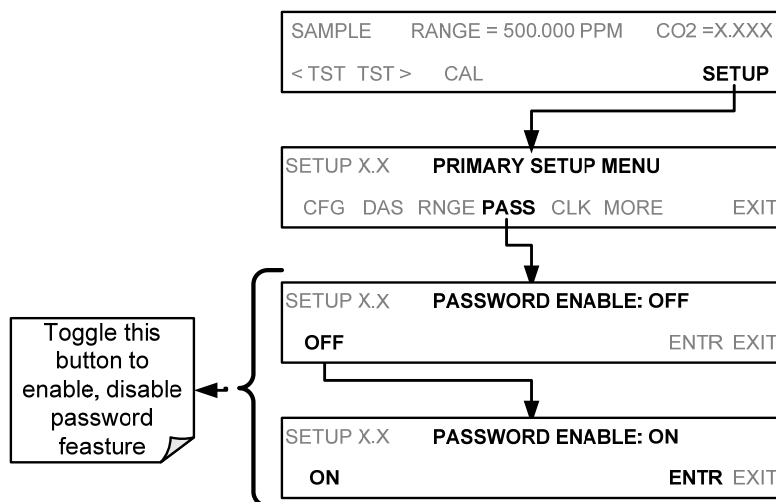

Example: If all passwords are enabled, the following keypad sequence would be required to enter the SETUP menu:

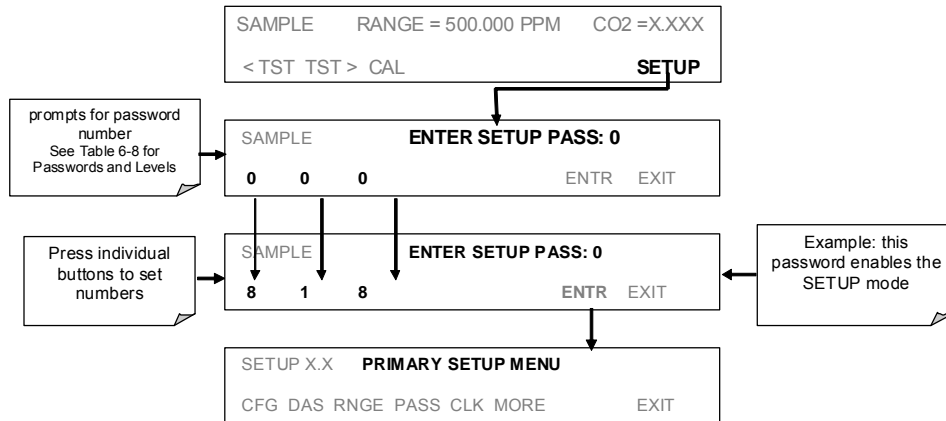

Note that the instrument still prompts for a password when entering the VARS and DIAG menus, even if passwords are disabled, but it displays the default password (818) upon entering these menus. The user only has to press ENTR to access the password-protected menus but does not have to enter the required number code.

6.10. SETUP → CLK: Setting the Internal Time-of-Day Clock

The GFC 7000T has a time of day clock that supports the AutoCal timer, time of day TEST function, and time stamps on most COM port messages. To set the time-of-day, press:

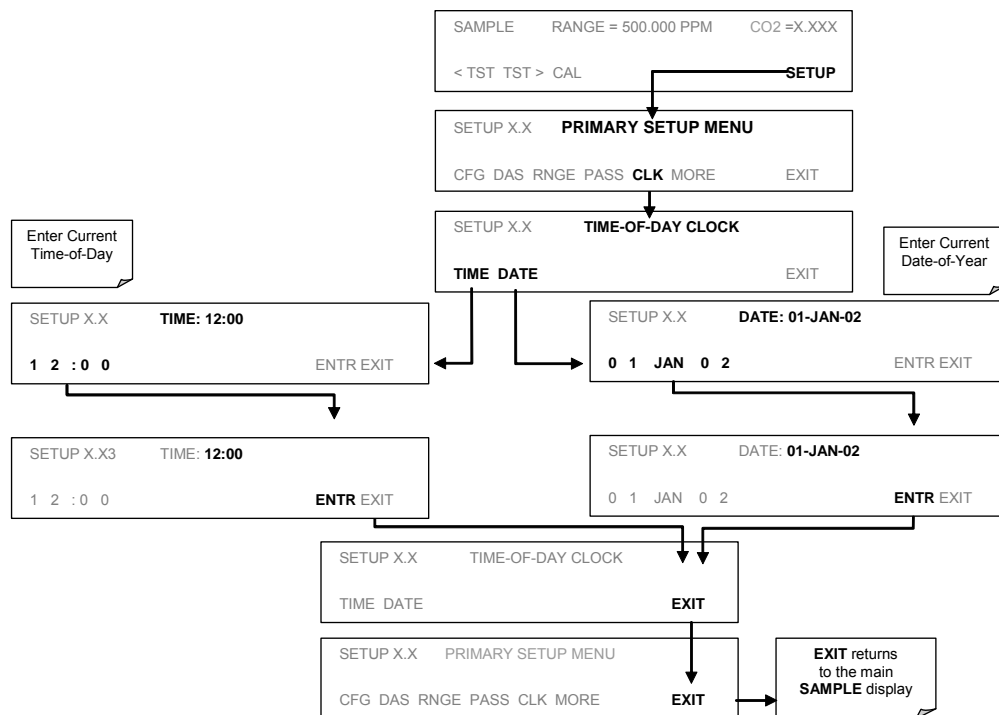

In order to compensate for CPU clocks which run faster or slower, you can adjust a variable called **CLOCK_ADJ** to speed up or slow down the clock by a fixed amount every day. To change this variable, press:

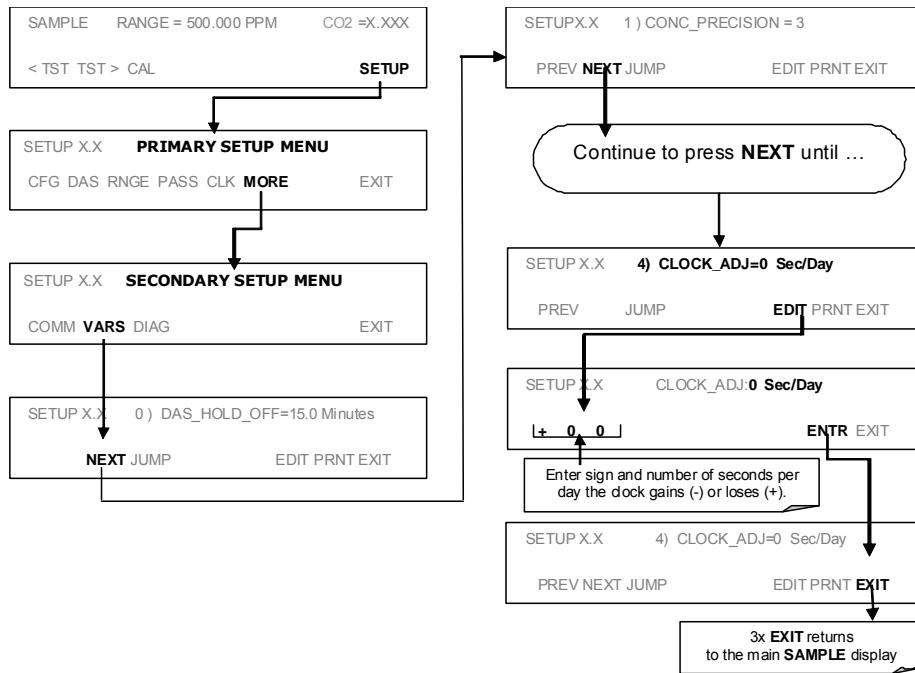

6.11. SETUP → MORE → COMM: Using the Analyzer's Communication Ports

The GFC 7000T is equipped with an Ethernet port, a USB port and two serial communication (COMM) ports located on the rear panel (Figure 3-2). Both com ports operate similarly and give the user the ability to communicate with, issue commands to, and receive data from the analyzer through an external computer system or terminal.

By default, both com ports operate on the RS-232 protocol.

- The RS232 port (used as COM1) can also be configured to operate in single or RS-232 multidrop mode (option 62; See Section 5.5.2 and 6.11.7).
- The COM2 port can be configured for standard RS-232 operation or half-duplex RS-485 communication (For RS-485 communication, please contact the factory).

A code-activated switch (CAS), can also be used on either port to connect typically between 2 and 16 send/receive instruments (host computer(s) printers, data loggers, analyzers, monitors, calibrators, etc.) into one communications hub. Contact Teledyne Instruments sales for more information on CAS systems.

6.11.1. Analyzer ID

Each type of Teledyne Instruments analyzer is configured with a default ID code. The default ID code for all GFC 7000T analyzers is **360**. The ID number is only important if more than one analyzer is connected to the same communications channel such as when several analyzers are on the same Ethernet LAN (See Section 6.11.6); in a RS-232 multidrop chain (See Section 6.11.7) or operating over a RS-485 network. If two analyzers of the same model type are used on one channel, the ID codes of one or both of the instruments needs to be changed.

To edit the instrument's ID code, press:

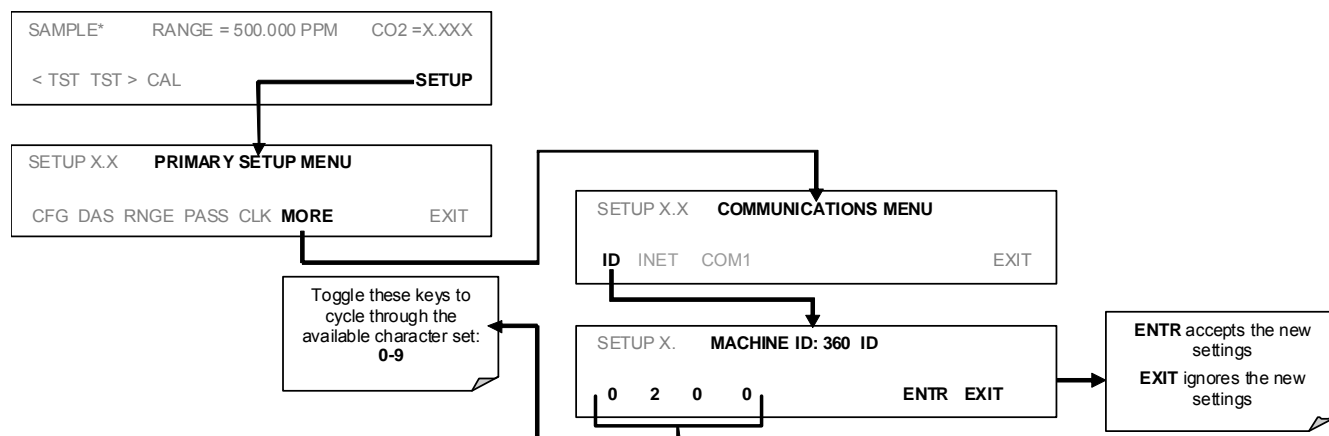

The ID number is only important if more than one analyzer is connected to the same communications channel (e.g., a multi-drop setup). Different models of Teledyne Instruments analyzers have different default ID numbers, but if two analyzers of the same model type are used on one channel (for example, two GFC 7000T's), the ID of one instrument needs to be changed.

The ID can also be used for to identify any one of several analyzers attached to the same network but situated in different physical locations.

6.11.2. COM Port Default Settings

Received from the factory, the analyzer is set up to emulate a DCE or modem, with pin 3 of the DB-9 connector designated for receiving data and pin 2 designated for sending data.

- **COM1:** RS-232 (fixed) DB-9 male connector.
 - **Baud rate:** 19200 bits per second (baud).
 - **Data Bits:** 8 data bits with 1 stop bit.
 - **Parity:** None.
- **COM2:** RS-232 (configurable), DB-9 female connector.
 - **Baud rate:** 115000 bits per second (baud).
 - **Data Bits:** 8 data bits with 1 stop bit.
 - **Parity:** None.

NOTE

Cables that appear to be compatible because of matching connectors may incorporate internal wiring that make the link inoperable. Check cables acquired from sources other than Teledyne Instruments for pin assignments before using.

In its default configuration, the GFC 7000T analyzer has two available RS-232 Com ports accessible via 2 DB-9 connectors on the back panel of the instrument. The COM1 connector is a male DB-9 connector and the COM2 is a female DB9 connector.

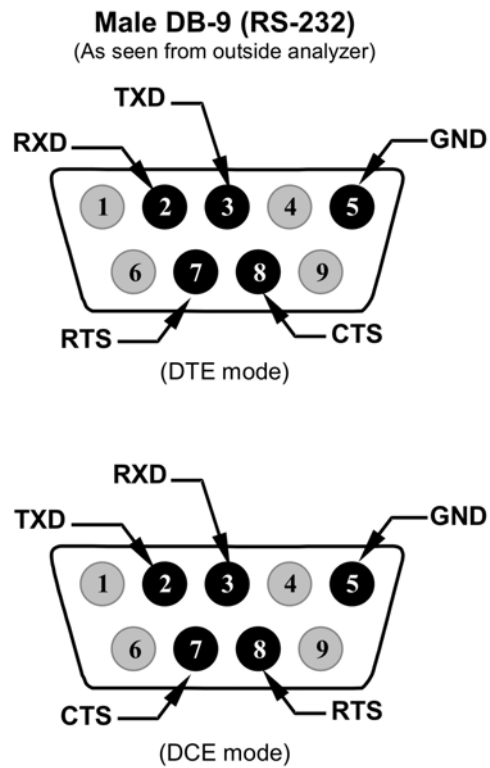

Figure 6-7: Rear Panel Connector Pin-Outs for COM1 & COM2 in RS-232 Mode

The signals from these two connectors are routed from the motherboard via a wiring harness to two 10-pin connectors on the CPU card, J11 and J12.

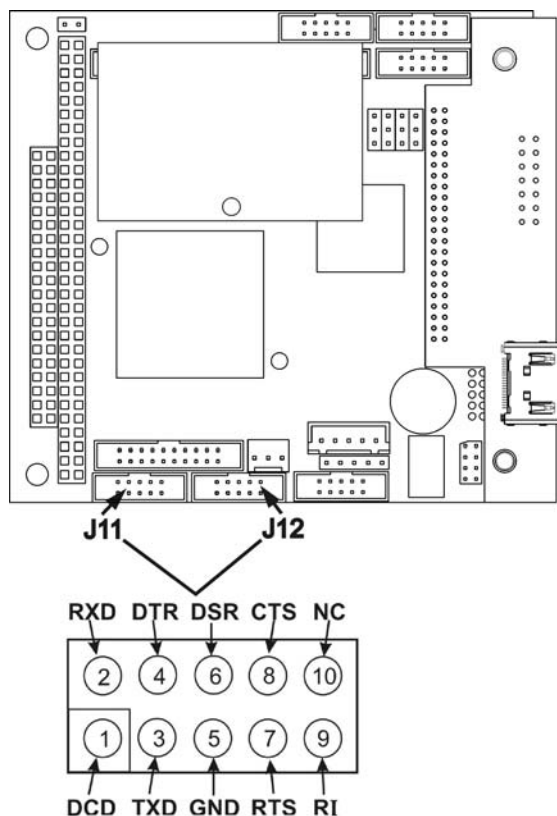

Figure 6-8: CPU Connector Pin-Outs for COM1 & COM2 in RS-232 Mode

Teledyne Instruments offers two mating cables, one of which should be applicable for your use.

- Part number WR000077, a DB-9 female to DB-9 female cable, 6 feet long. Allows connection of COM1 with the serial port of most personal computers. Also available as Option 60 (See Section 5.5.1).
- Part number WR000024, a DB-9 female to DB-25 male cable. Allows connection to the most common styles of modems (e.g. Hayes-compatible) and code activated switches.

Both cables are configured with straight-through wiring and should require no additional adapters.

To assist in properly connecting the serial ports to either a computer or a modem, there are activity indicators just above the RS-232 port. Once a cable is connected between the analyzer and a computer or modem, both the red and green LEDs should be on. If the lights for COM 1 are not lit, use small switch on the rear panel to switch it between DTE and DCE modes (See Section 6.11.4). If both LEDs are still not illuminated, check the cable for proper wiring.

6.11.3. RS-485 Configuration of COM2

As delivered from the factory, COM2 is configured for RS-232 communications. To configure this port for RS-485 communication, please contact the factory. If COM2 is configured for RS-485, the USB com port is no longer enabled.

6.11.4. DTE and DCE Communication

RS-232 was developed for allowing communications between data terminal equipment (DTE) and data communication equipment (DCE). Basic terminals always fall into the DTE category whereas modems are always considered DCE devices. The difference between the two is the pin assignment of the Data Receive and Data Transmit functions. DTE devices receive data on pin 2 and transmit data on pin 3; DCE devices receive data on pin 3 and transmit data on pin 2.

To allow the analyzer to be used with terminals (DTE), modems (DCE) and computers (which can be either), a switch mounted below the serial ports on the rear panel allows the user to switch between the two functions.

6.11.5. COM Port Communication Modes

Each of the analyzer's serial ports can be configured to operate in a number of different modes, listed in Table 6-10 which can be combined by adding the mode ID numbers. For example, quiet mode, computer mode and internet-enabled mode would carry a combined mode ID of 11, the standard configuration on the GFC 7000T **COM2** port. Note that each COM port needs to be configured independently.

Table 6-10: Com Port Communication Modes

MODE ¹	ID	DESCRIPTION
QUIET	1	Quiet mode suppresses any feedback from the analyzer (DAS reports, and warning messages) to the remote device and is typically used when the port is communicating with a computer program such as APICOM. Such feedback is still available but a command must be issued to receive them.
COMPUTER	2	Computer mode inhibits echoing of typed characters and is used when the port is communicating with a computer program, such as APICOM.
SECURITY	4	When enabled, the serial port requires a password before it will respond. The only command that is active is the help screen (? CR).
TAI PROTOCOL	16384	Protocol for communication with a TAI Valve Box.
E, 7, 1	2048	When turned on this mode switches the com port settings from No parity; 8 data bits; 1 stop bit to Even parity; 7 data bits; 1 stop bit
RS-485	1024	Configures the COM2 Port for RS-485 communication. RS-485 mode has precedence over multidrop mode if both are enabled.
MULTIDROP PROTOCOL	32	Multidrop protocol allows a multi-instrument configuration on a single communications channel. Multidrop requires the use of instrument IDs.
ENABLE MODEM	64	Enables to send a modem initialization string at power-up. Asserts certain lines in the RS-232 port to enable the modem to communicate.
ERROR CHECKING ²	128	Fixes certain types of parity errors.
XON/XOFF HANDSHAKE ²	256	Disables XON/XOFF data flow control also known as software handshaking.
HARDWARE HANDSHAKE	8	Enables CTS/RTS style hardwired transmission handshaking. This style of data transmission handshaking is commonly used with modems or terminal emulation protocols as well as by Teledyne Instrument's APICOM software.
HARDWARE FIFO ²	512	Improves data transfer rate when on of the com ports.
COMMAND PROMPT	4096	Enables a command prompt when in terminal mode.
¹ Modes are listed in the order in which they appear in the SETUP → MORE → com → COM[1 OR 2] → MODE menu		
² The default sting for this feature is ON . Do not disable unless instructed to by Teledyne Instruments Customer Service personnel.		

Press the following touchscreen buttons to select a communication mode for one of the com Ports, such as the following example where **TAI PROTOCOL** mode is enabled:

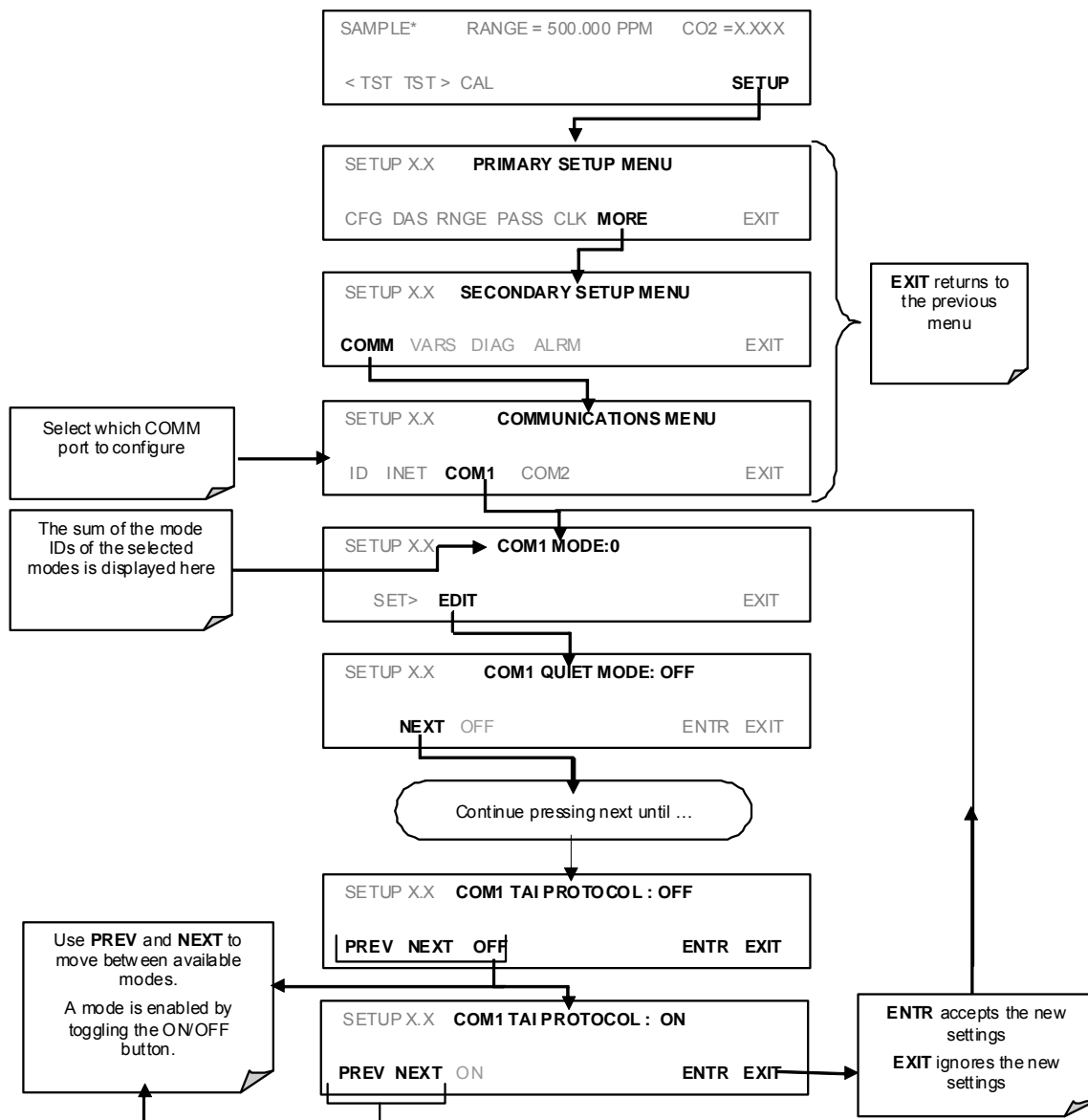

6.11.6. Remote Access via the Ethernet

When using the Ethernet interface, the analyzer can be connected to any standard 10BaseT or 100Base T Ethernet network via low-cost network hubs, switches or routers. The interface operates as a standard TCP/IP device on a user selectable port, which otherwise defaults to port 3000. This allows a remote computer to connect through the internet to the analyzer using APICOM, terminal emulators or other programs.

The Ethernet connector has two LEDs that are on the connector itself, indicating its current operating status.

Table 6-11: Ethernet Status Indicators

LED	Function
amber (link)	On when connection to the LAN is valid.
green (activity)	Flickers during any activity on the LAN.

6.11.6.1. Configuring the Ethernet Interface using DHCP

The Ethernet option for your analyzer uses Dynamic Host Configuration Protocol (DHCP) to automatically configure its interface with your LAN. This requires your network servers also be running DHCP. The analyzer will do this the first time you turn the instrument on after it has been physically connected to your network. Once the instrument is connected and turned on it will appear as an active device on your network without any extra set up steps or lengthy procedures.

Table 6-12: LAN/Internet Configuration Properties

PROPERTY	DEFAULT STATE	DESCRIPTION
DHCP	ON	This displays whether the DHCP is turned ON or OFF. Press EDIT and toggle ON for automatic configuration after first consulting network administrator. (
INSTRUMENT IP ADDRESS		This string of four packets of 1 to 3 numbers each (e.g. 192.168.76.55.) is the address of the analyzer itself.
GATEWAY IP ADDRESS	0.0.0.0	Can only be edited when DHCP is set to OFF. A string of numbers very similar to the Instrument IP address (e.g. 192.168.76.1.) that is the address of the computer used by your LAN to access the Internet.
SUBNET MASK	0.0.0.0	Can only be edited when DHCP is set to OFF. Also a string of four packets of 1 to 3 numbers each (e.g. 255.255.252.0) that identifies the LAN to which the device is connected. All addressable devices and computers on a LAN must have the same subnet mask. Any transmissions sent to devices with different subnets are assumed to be outside of the LAN and are routed through the gateway computer onto the Internet.
TCP PORT ¹	3000	This number defines the terminal control port by which the instrument is addressed by terminal emulation software, such as Internet or Teledyne's APICOM.
HOST NAME	T100	The name by which your analyzer will appear when addressed from other computers on the LAN or via the Internet. To change, see Section 6.11.6.3.
¹ Do not change the setting for this property unless instructed to by Teledyne Customer Service personnel.		

NOTE

It is a good idea to check these settings the first time you power up your analyzer after it has been physically connected to the LAN/Internet to make sure that the DHCP has successfully downloaded the appropriate information from you network server(s).

If the gateway IP, instrument IP and the subnet mask are all zeroes (e.g. "0.0.0.0"), the DCHP was not successful.

You may have to manually configure the analyzer's Ethernet properties. See your network administrator.



To view the above properties, press:

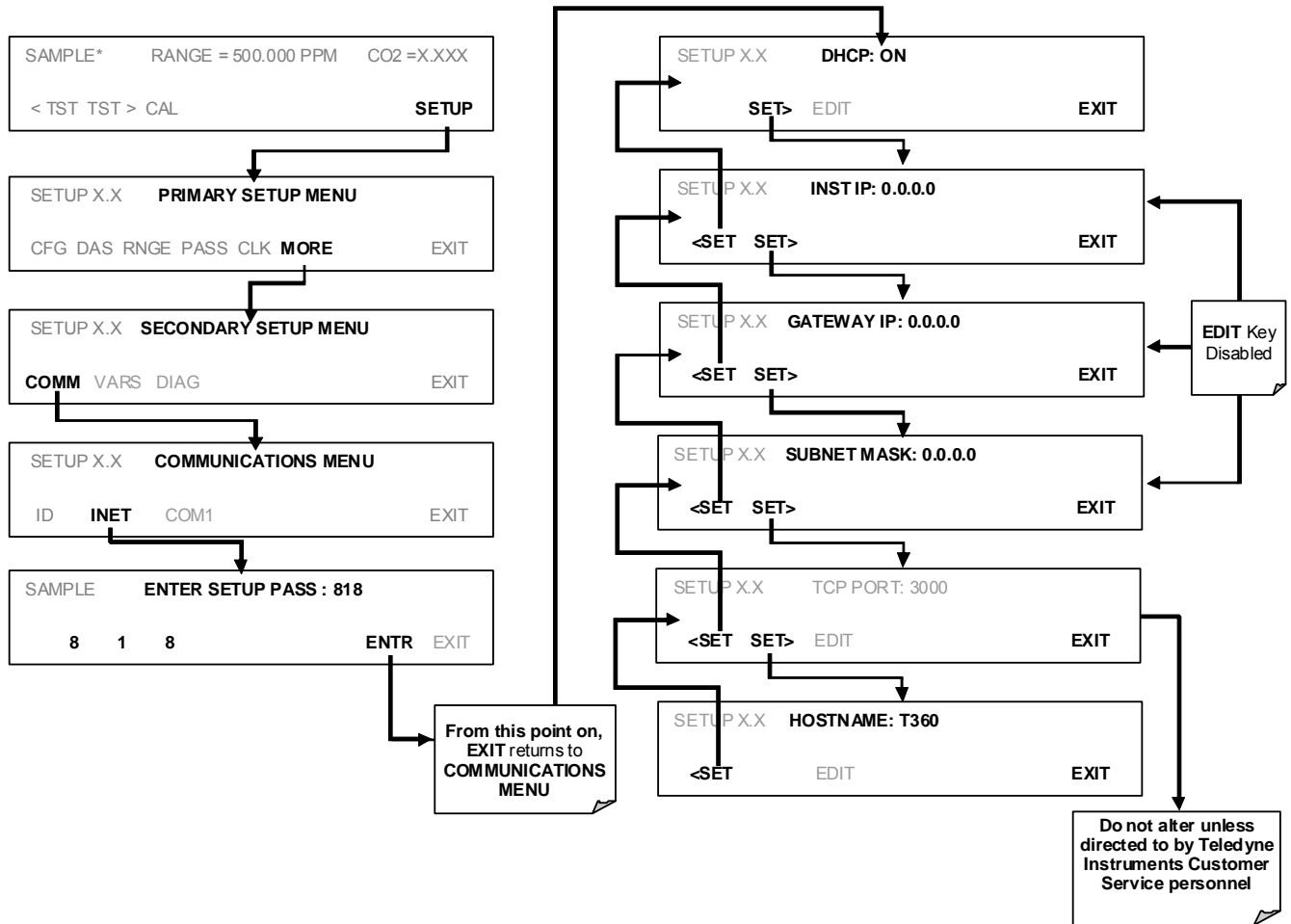

6.11.6.2. Manually Configuring the Ethernet (Static IP Address)

To configure Ethernet communication manually:

1. Connect a cable from the analyzer's Ethernet port to a Local Area Network (LAN) or Internet port.
2. From the analyzer's front panel touchscreen, access the Communications Menu as shown below, turning DHCP mode to OFF.

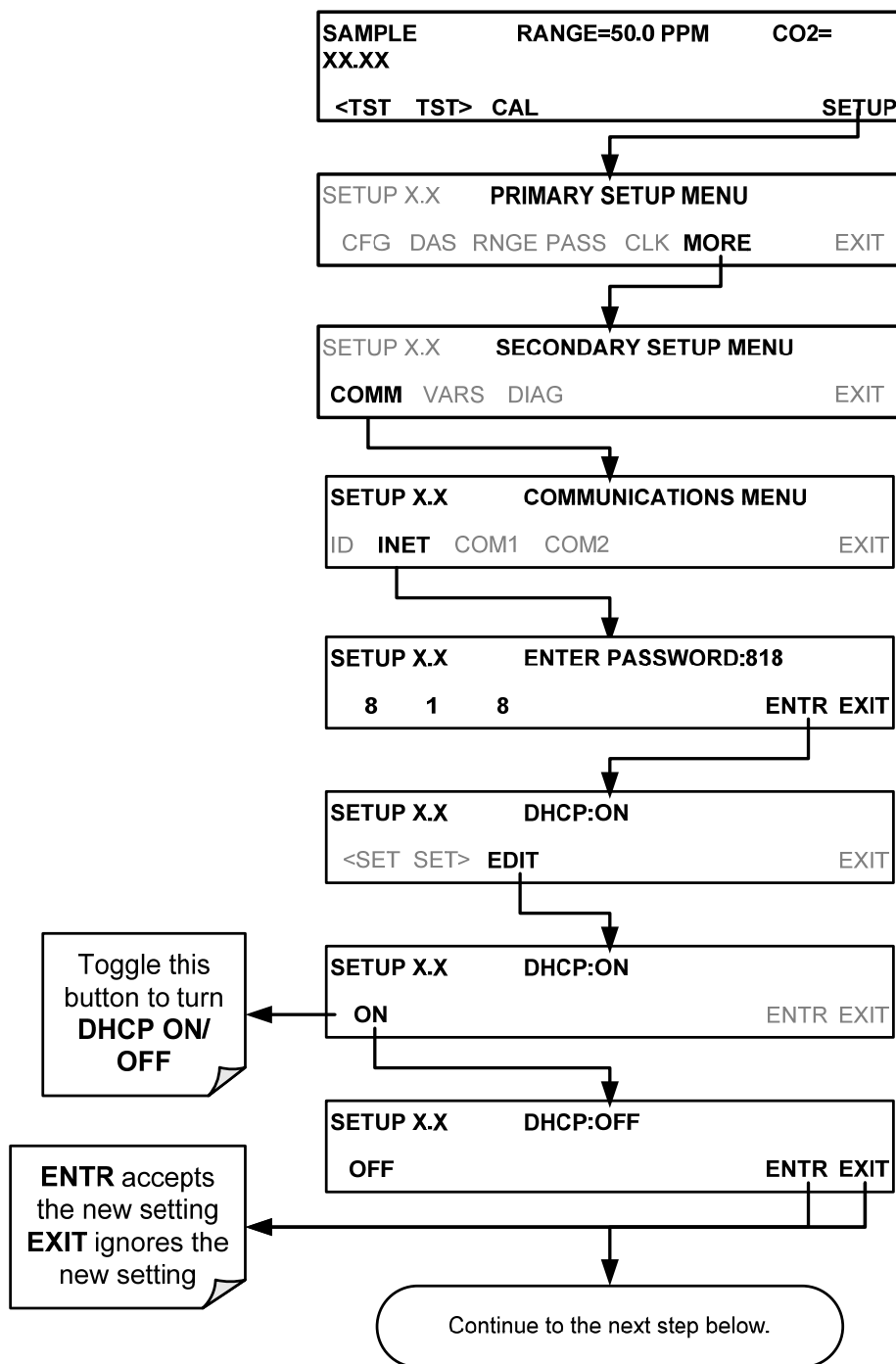

Next, refer to Table 6-12 for the default Ethernet configuration settings and configure the **INSTRUMENT IP** addresses by pressing:

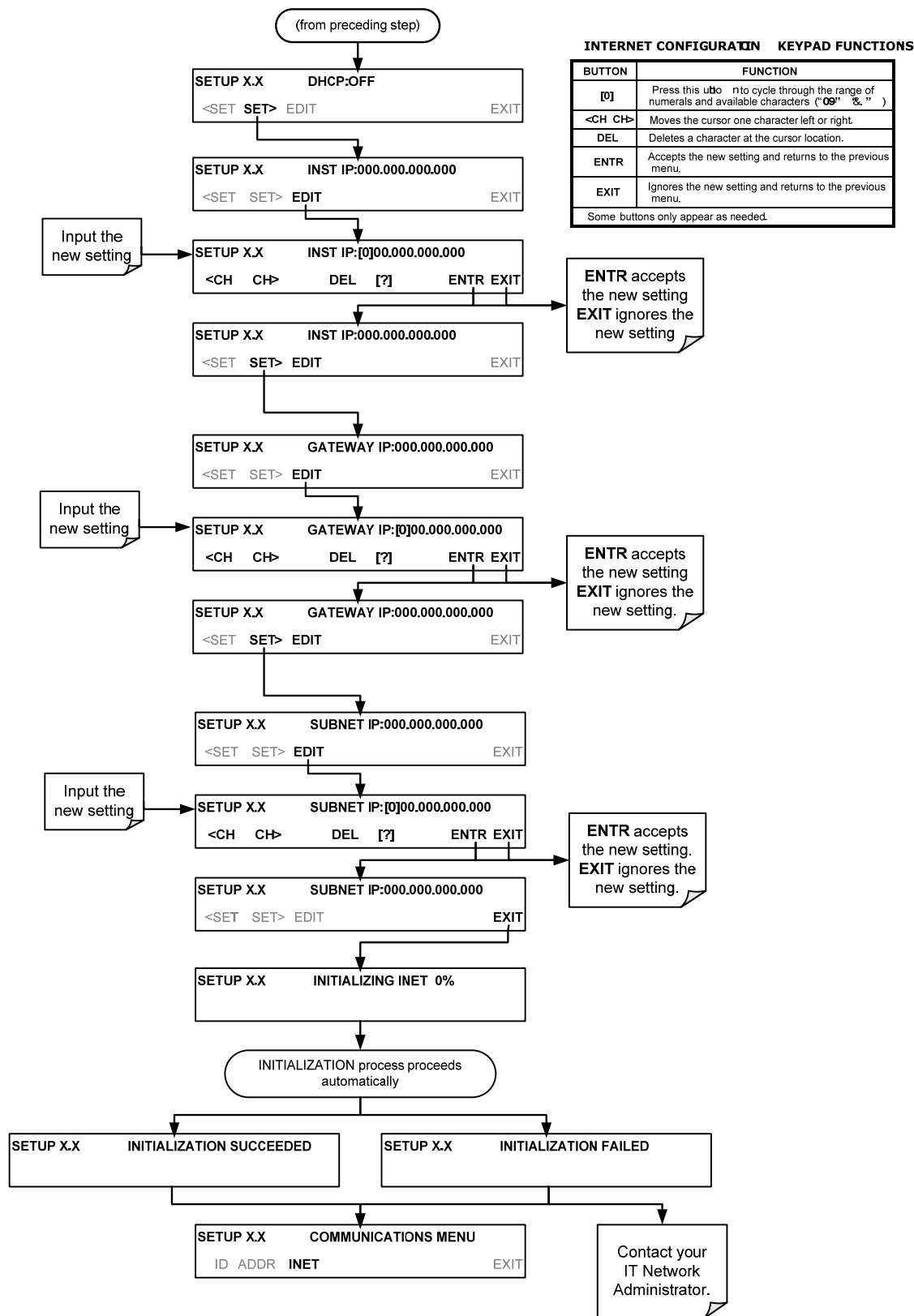

6.11.6.3. Changing the Analyzer's HOSTNAME

The **HOSTNAME** is the name by which the analyzer appears on your network. The default name for all Teledyne Instruments Model GFC 7000T analyzers is **GFC 7000T**. To change this name (particularly if you have more than one Model GFC 7000T analyzer on your network), press.

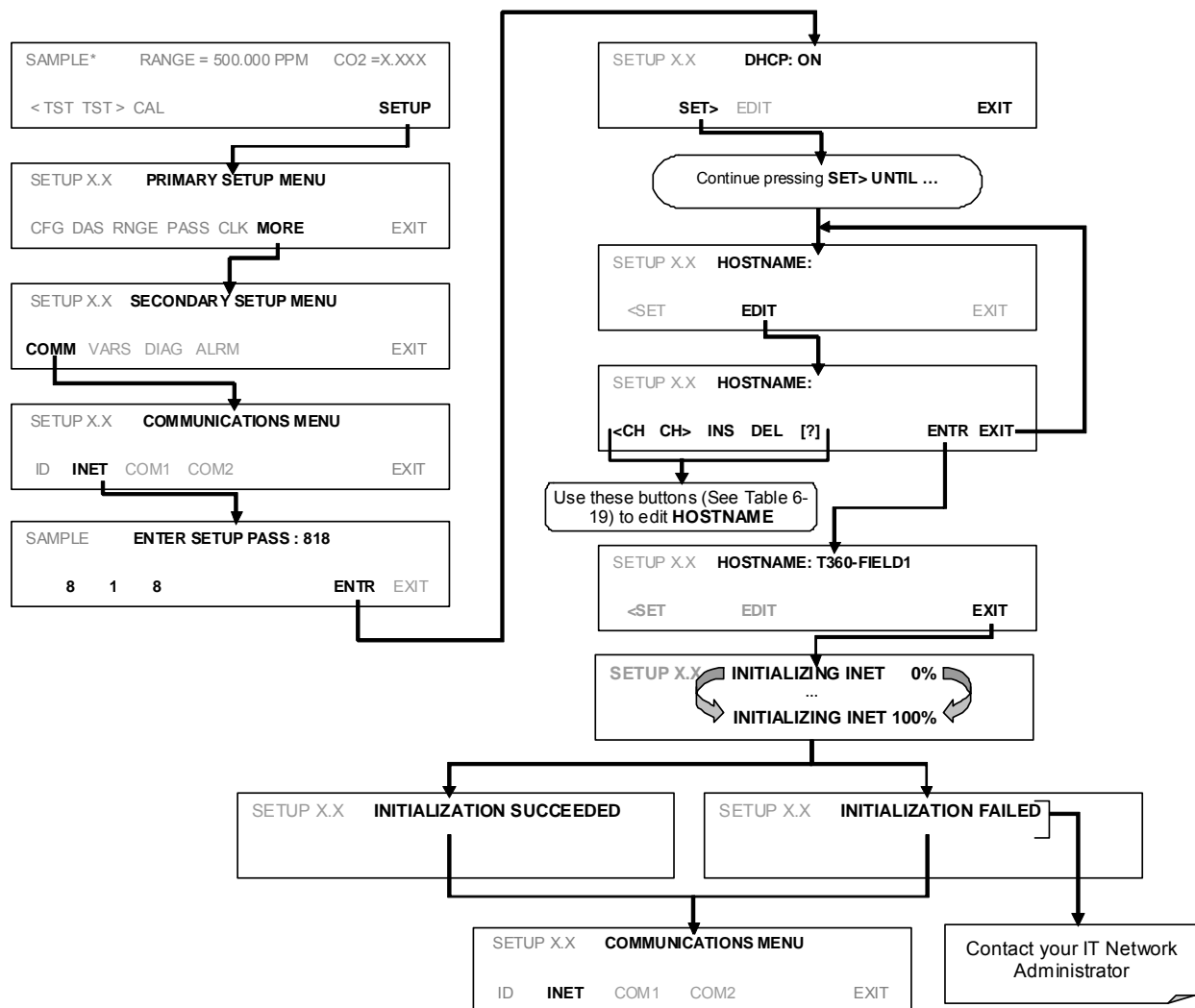

Table 6-13: Internet Configuration Touchscreen Functions

BUTTON	FUNCTION
<CH	Moves the cursor one character to the left.
CH>	Moves the cursor one character to the right.
INS	Inserts a character before the cursor location.
DEL	Deletes a character at the cursor location.
[?]	Press this button to cycle through the range of numerals and characters available for insertion. 0-9, A-Z, space ' ~ ! @ # \$ % ^ & * () - _ = + [] { } < > \ ; : , . / ?
ENTR	Accepts the new setting and returns to the previous menu.
EXIT	Ignores the new setting and returns to the previous menu.
Some buttons only appear as applicable.	

6.11.7. Multidrop RS-232 Set Up

The RS-232 multidrop consists of a printed circuit assembly that is seated on the analyzer's CPU card (see Figures 6-10 and 6-13) and is connected to the CPU and the motherboard. This PCA includes all circuitry required to enable your analyzer for multidrop operation. It converts the instrument's RS232 port to multidrop configuration allowing up to eight analyzers to be connected the same I/O port of the host computer.

Because both of the DB9 connectors on the analyzer's back panel are needed to construct the multidrop chain, COM2 is no longer available for separate RS-232 or RS-485 operation; however, the USB com port is available.

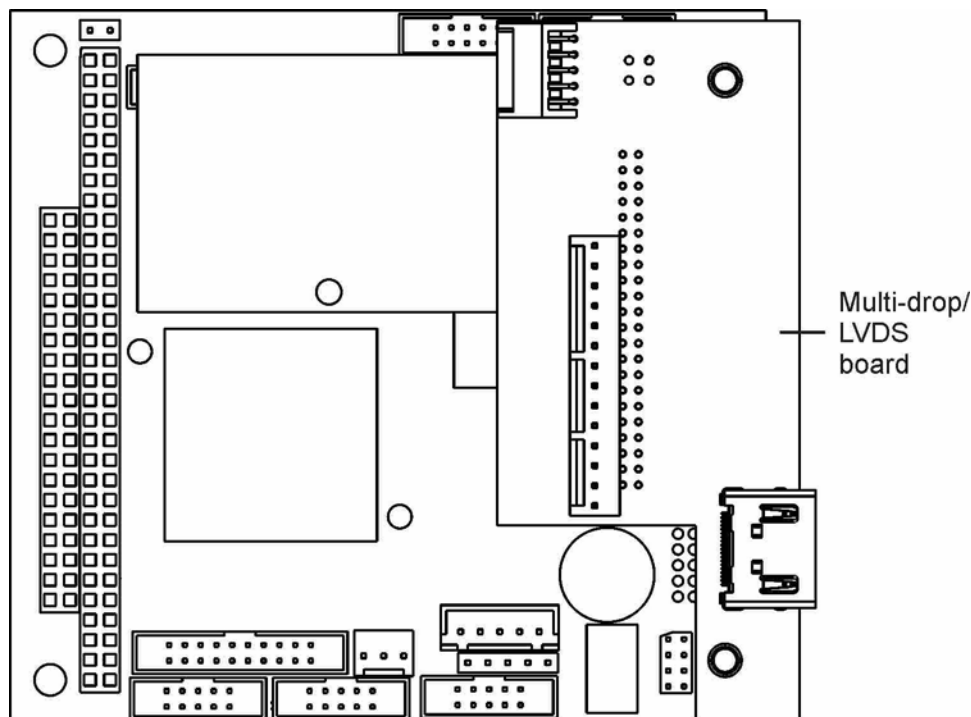

Figure 6-9: Multidrop/LVDS PCA Seated on CPU

Each analyzer in the multidrop chain must have:

- One Teledyne Instruments option 62 installed.
- One 6' straight-through, DB9 male → DB9 Female cable (Teledyne Instruments P/N WR0000101) is required for each analyzer.

To set up the network, for each analyzer:

1. With NO power to the instrument, open the rear panel and locate the CPU.
2. On the LVDS card, disconnect the cable that's connected to J1 and remove the LVDS card from the CPU card.
3. Mount the Multidrop/LVDS card onto the CPU and reconnect the LVDS cable to J1.

4. Connect a cable between the Multidrop/LVDS card J4 and the motherboard P12.
5. Connect a cable between the Multidrop/LVDS card J3 and the CPU COM1 connector.
6. Close the instrument.
7. Using straight-through, DB9 male → DB9 Female cable, interconnect the host and the analyzers as shown in Figure 6-14.
8. BEFORE communicating from the host, power on the instruments and check that the Machine ID code is unique for each (see Section Analyzer ID). On the front panel menu, use SETUP>MORE>COMM>ID. Note that the default ID is typically the model number; to change the 4-digit identification number, press the button of the digit to be changed)..

NOTE:

Teledyne Instruments recommends setting up the first link, between the Host and the first analyzer and testing it before setting up the rest of the chain.

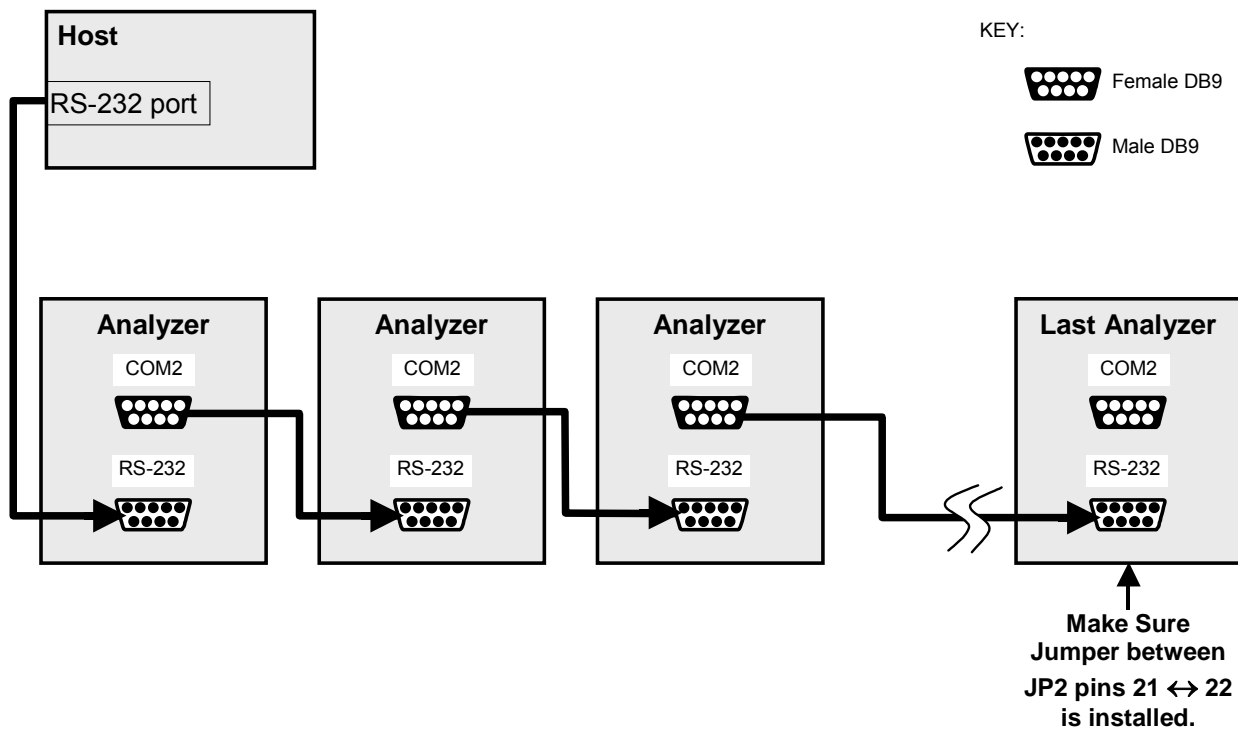
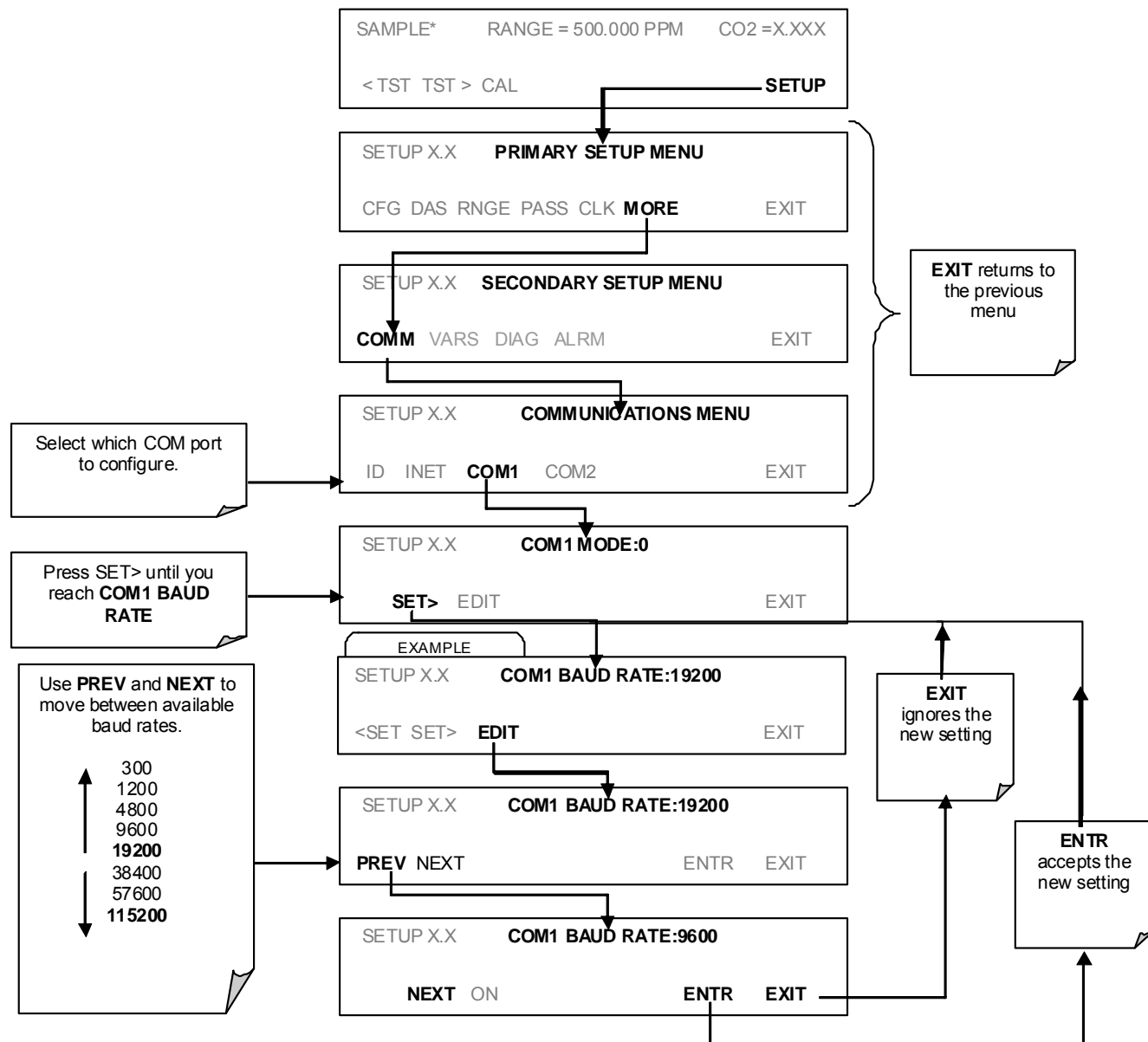

Figure 6-10: RS232-Multidrop PCA Host/Analyzer Interconnect Diagram

6.11.8. COM Port Baud Rate

To select the baud rate of one of the COM Ports, press:



6.11.9. COM Port Testing

The serial ports can be tested for correct connection and output in the com menu. This test sends a string of 256 'w' characters to the selected COM port. While the test is running, the red LED on the rear panel of the analyzer should flicker.

To initiate the test press the following touchscreen button sequence.

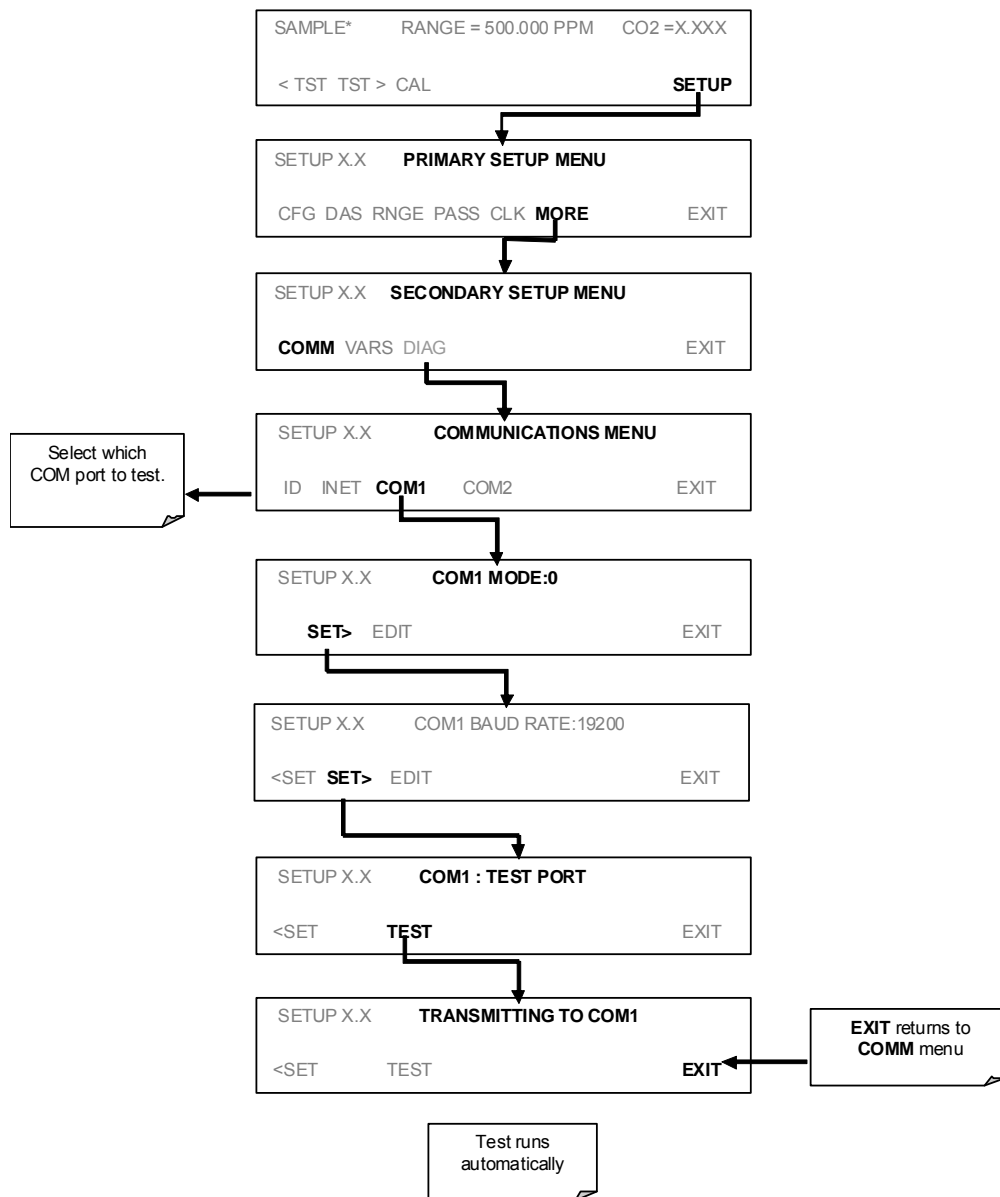

6.12. SETUP → MORE → VARS: Internal Variables (VARS)

The GFC 7000T has several-user adjustable software variables, which define certain operational parameters. Usually, these variables are automatically set by the instrument's firmware, but can be manually re-defined using the VARS menu. Table 6-14 lists all variables that are available within the 818 password protected level.

Table 6-14: Variable Names (VARS) Revision B.3

NO.	VARIABLE	DESCRIPTION	ALLOWED VALUES
0	DAS_HOLD_OFF	Changes the internal data acquisition system (DAS) hold-off time, which is the duration when data are not stored in the DAS because the software considers the data to be questionable. That is the case during warm-up or just after the instrument returns from one of its calibration modes to SAMPLE mode. DAS_HOLD_OFF can be disabled entirely in each DAS channel.	Can be between 0.5 and 20 minutes Default=15 min.
1	CONC_PRECISION	Allows the user to set the number of significant digits to the right of the decimal point display of concentration and stability values.	AUTO, 1, 2, 3, 4 Default=AUTO
2	STABIL_GAS	Selects which gas measurement is displayed when the STABIL test function is selected.	CO ₂ & O ₂ ¹
3	DYN_ZERO	Dynamic zero automatically adjusts offset and slope of the CO ₂ response when performing a zero point calibration during an AutoCal (Section 7).	ON/OFF
4	DYN_SPAN	Dynamic span automatically adjusts slope and slope of the CO ₂ response when performing a zero point calibration during an AutoCal (Section 7). Note that the DYN_ZERO and DYN_SPAN features are not allowed for applications requiring EPA equivalency.	ON/OFF
5	CLOCK_ADJ	Adjusts the speed of the analyzer's clock. Choose the + sign if the clock is too slow, choose the - sign if the clock is too fast.	-60 to +60 s/day

¹ O₂ option is only available in analyzers with O₂ sensor options installed.

To access and navigate the VARS menu, use the following touchscreen button sequence.

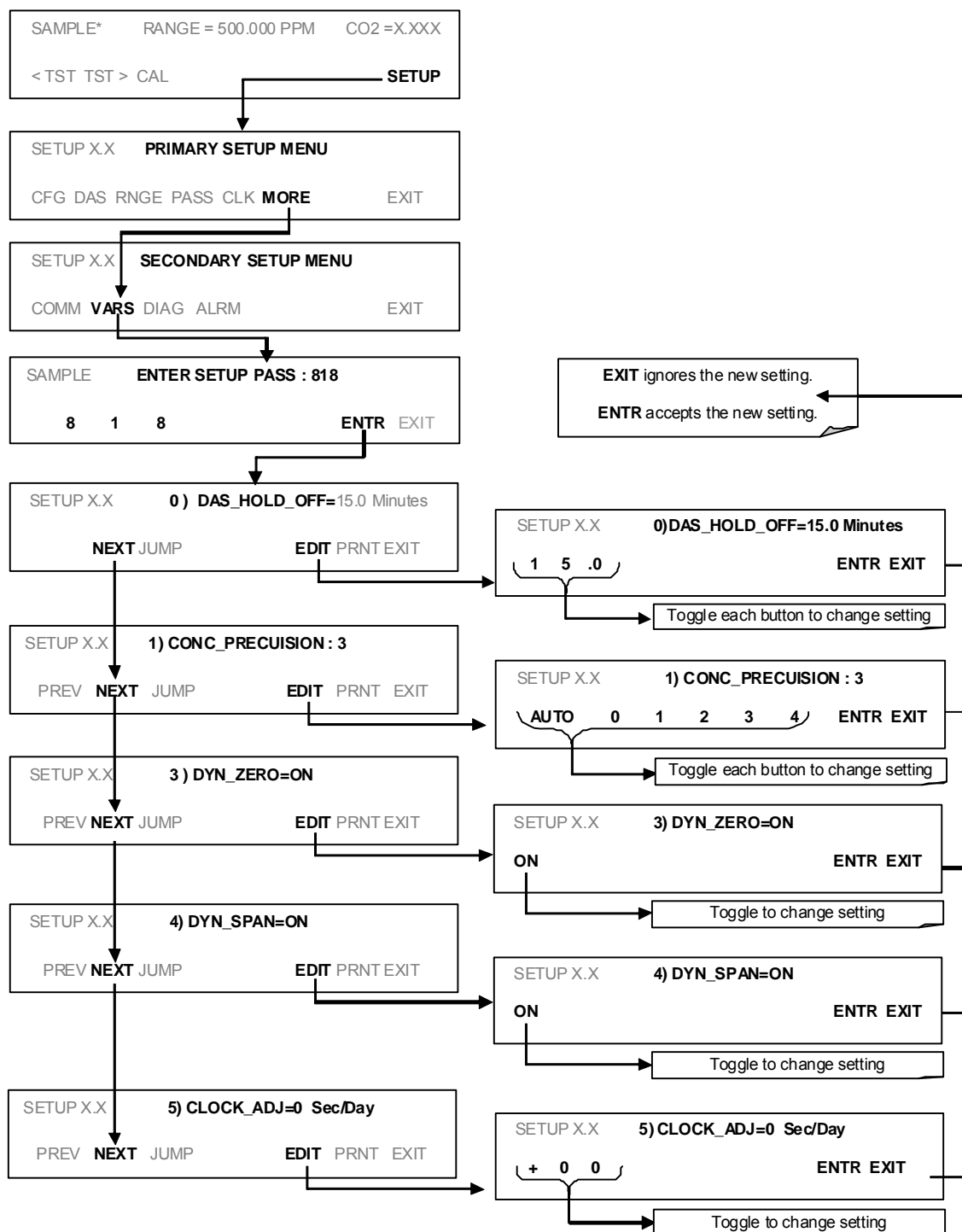

6.13. SETUP → MORE → DIAG: Using the Diagnostics Functions

A series of diagnostic tools is grouped together under the **SETUP→MORE→DIAG** menu. As these parameters are dependent on firmware revision (see Menu Tree A-6 in Appendix A). The individual parameters, however, are explained in more detail in the indicated in 6-15. These tools can be used in a variety of troubleshooting and diagnostic procedures and are referred to in many places of the maintenance and trouble-shooting s.

Table 6-15: GFC 7000T Diagnostic (DIAG) Functions

DIAGNOSTIC FUNCTION AND MEANING	Front Panel Mode Indicator	
SIGNAL I/O: Allows observation of all digital and analog signals in the instrument. Allows certain digital signals such as valves and heaters to be toggled ON and OFF.	DIAG I/O	6.13.2
ANALOG OUTPUT: When entered, the analyzer performs an analog output step test. This can be used to calibrate a chart recorder or to test the analog output accuracy.	DIAG AOUT	6.13.3
ANALOG I/O CONFIGURATION: the signal levels of the instruments analog outputs may be calibrated (either individually or as a group). Various electronic parameters such as signal span, and offset are available for viewing and configuration.	DIAG AIO	6.13.4
ELECTRIC TEST: The analyzer is performing an electric test. This test simulates IR detector signal in a known manner so that the proper functioning of the sync/demod board can be verified.	DIAG OPTIC	6.13.5
DARK CALIBRATION: The analyzer is performing a dark calibration procedure. This procedure measures and stores the inherent dc offset of the sync/demod board electronics.	DIAG ELEC	6.13.6
PRESSURE CALIBRATION: The analyzer records the current output of the sample gas pressure sensor. This value is used by the CPU to compensate the CO ₂ concentration.	DIAG PCAL	6.13.7
FLOW CALIBRATION: This function is used to calibrate the gas flow output signal. This setting is retained when exiting DIAG .	DIAG FCAL	6.13.8
TEST CHAN OUTPUT: Configures the A4 analog output channel.	DIAG TCHN	6.13.9

6.13.1. Accessing the Diagnostic Features

To access the **DIAG** functions press the following buttons:

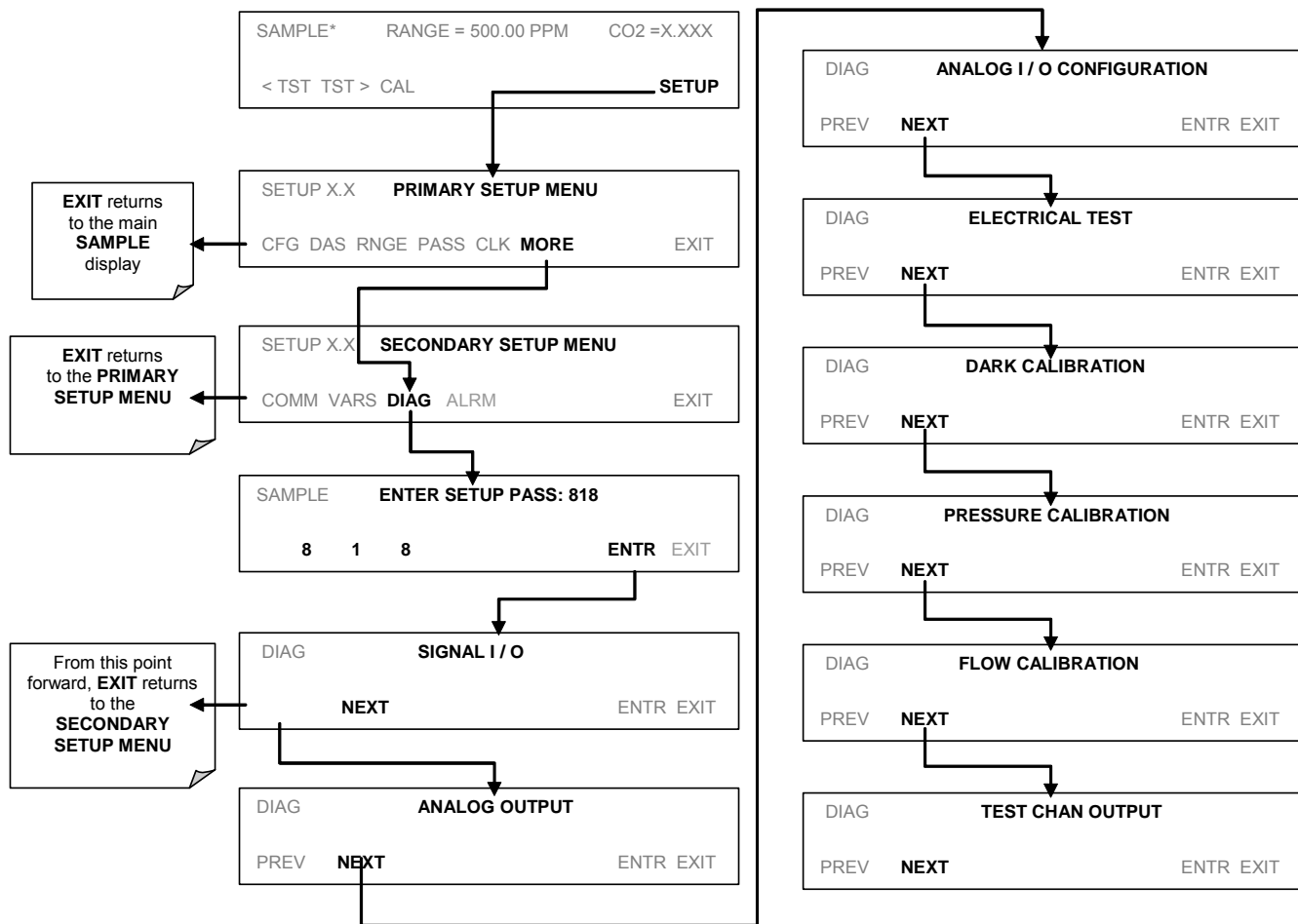

6.13.2. Signal I/O

The signal I/O diagnostic mode allows reviewing and changing the digital and analog input/output functions of the analyzer. See Appendix A-4 for a complete list of the parameters available for review under this menu.

NOTE

Any changes of signal I/O settings will remain in effect only until the signal I/O menu is exited. Exceptions are the ozone generator override and the flow sensor calibration, which remain as entered when exiting.

To enter the signal I/O test mode, press:

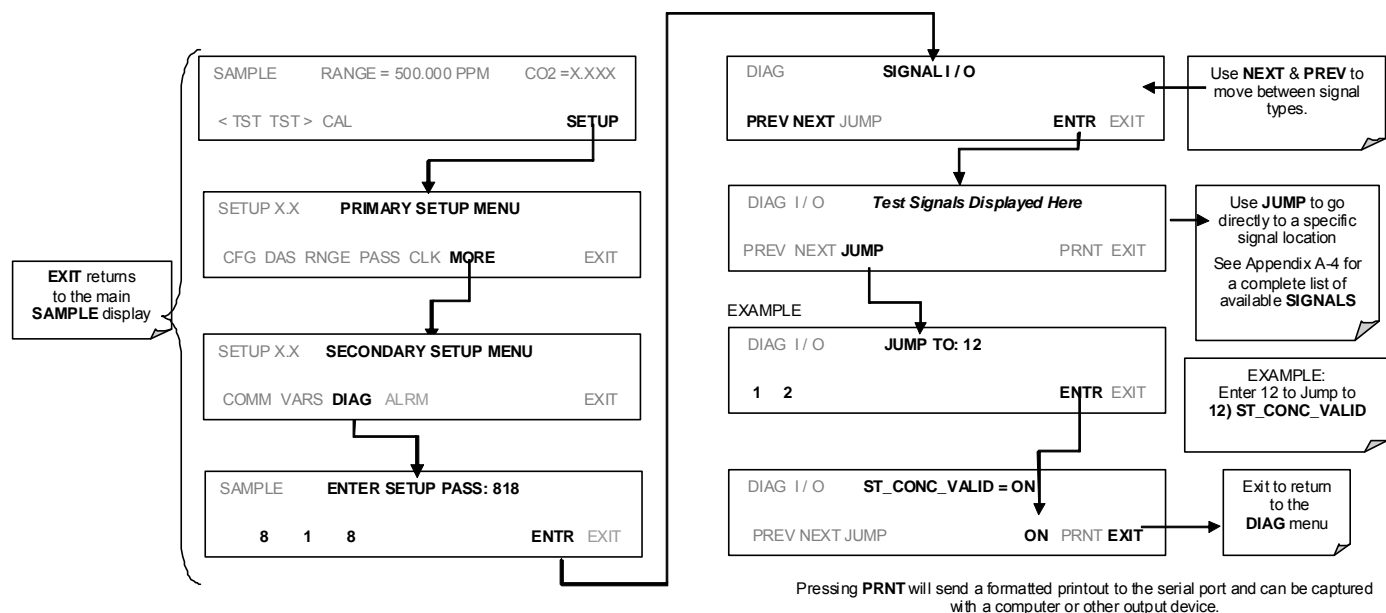

6.13.3. Analog Output Step Test

This test can be used to check the accuracy and proper operation of the analog outputs. The test forces all four analog output channels to produce signals ranging from 0% to 100% of the full scale range in 20% increments. This test is useful to verify the operation of the data logging/recording devices attached to the analyzer.

To begin the Analog Output Step Test press:

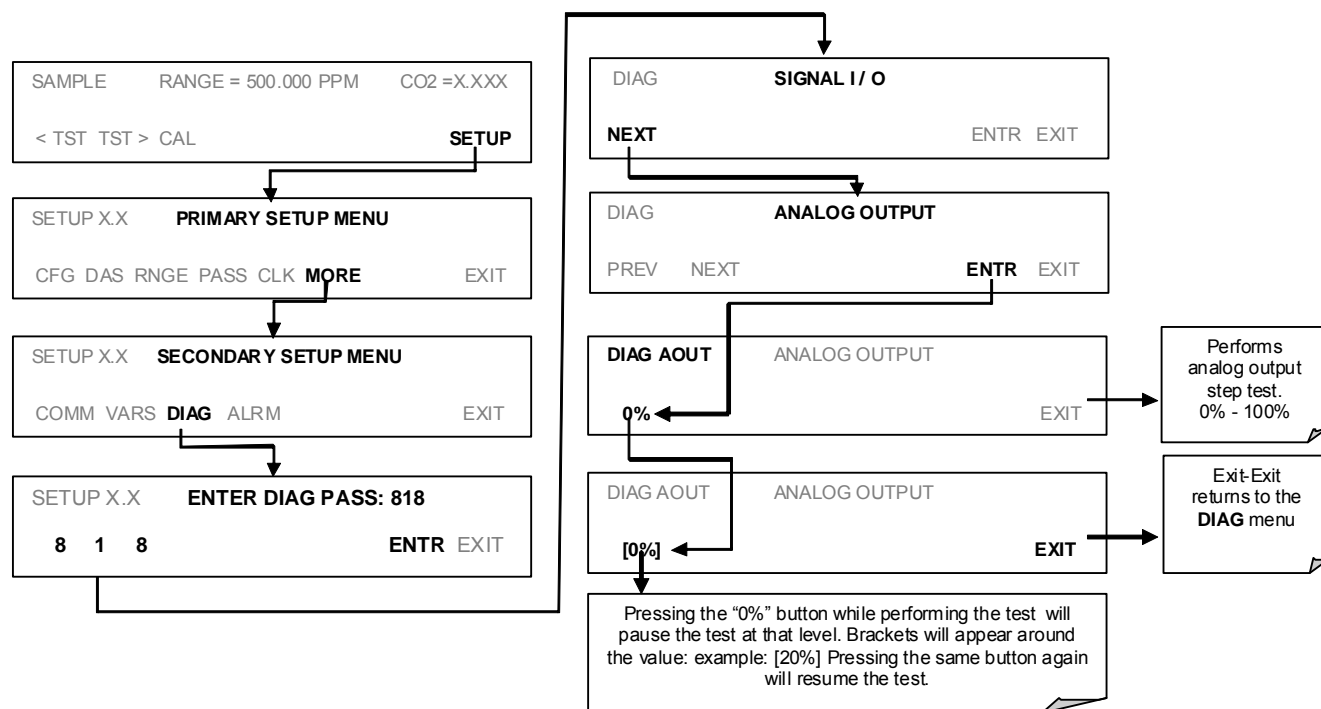

6.13.4. Analog I/O Configuration

The analog I/O functions that are available in the GFC 7000T are:

Table 6-16: DIAG - Analog I/O Functions

Sub Menu	Function
AOUTS CALIBRATED:	Shows the status of the analog output calibration (YES/NO) and initiates a calibration of all analog output channels.
CONC_OUT_1	Sets the basic electronic configuration of the A1 analog output (CO ₂). There are three options: Range: Selects the signal type (voltage or current loop) and full scale level of the output. REC_OFS: Allows setting a voltage offset (not available when RANGE is set to CURRent loop. Auto_CAL: Performs the same calibration as AOUT CALIBRATED, but on this one channel only. NOTE: Any change to RANGE or REC_OFS requires recalibration of this output.
CONC_OUT_2	Same as for CONC_OUT_1 but for analog channel 2 (CO ₂)
TEST OUTPUT	Same as for CONC_OUT_1 but for analog channel 4 (TEST)
AIN CALIBRATED	Shows the calibration status (YES/NO) and initiates a calibration of the analog to digital converter circuit on the motherboard.
XIN1 . . . XIN8	For each of 8 external analog input channels, shows the gain, offset, engineering units, and whether the channel is to show up as a Test function.

To configure the analyzer's three analog outputs, set the electronic signal type of each channel and calibrate the outputs. This consists of:

- Selecting an output type (voltage or current, if an optional current output driver has been installed) and the signal level that matches the input requirements of the recording device attached to the channel, See Section 6.13.4.1.
- Calibrating the output channel. This can be done automatically or manually for each channel, see Section 6.13.4.2 and 6.13.4.3.
- Adding a bipolar recorder offset to the signal, if required (Section 6.13.4.2.)

In its standard configuration, the analyzer's outputs can be set for the following DC voltages. Each range is usable from -5% to + 5% of the nominal range.

Table 6-17: Analog Output Voltage Ranges

RANGE	MINIMUM OUTPUT	MAXIMUM OUTPUT
0-0.1 V	-5 mV	+105 mV
0-1 V	-0.05 V	+1.05 V
0-5 V	-0.25 V	+5.25 V
0-10 V	-0.5 V	+10.5 V
The default offset for all ranges is 0 VDC.		

The following DC current output limits apply to the current loop modules:

Table 6-18: Analog Output Current Loop Range

RANGE	MINIMUM OUTPUT	MAXIMUM OUTPUT
0-20 mA	0 mA	20 mA
These are the physical limits of the current loop modules, typical applications use 2-20 or 4-20 mA for the lower and upper limits. Please specify desired range when ordering this option. The default offset for all ranges is 0 mA.		

Pin assignments for the output connector at the rear panel of the instrument are shown in Table 6-19.

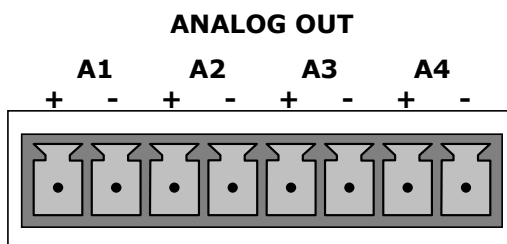

Table 6-19: Analog Output Pin Assignments

PIN	ANALOG OUTPUT	VOLTAGE SIGNAL	CURRENT SIGNAL
1	A1	V Out	I Out +
2		Ground	I Out -
3	A2	V Out	I Out +
4		Ground	I Out -
5	A3 ¹	V Out	I Out +
6		Ground	I Out -
7	A4	V Out	Not used
8		Ground	Not used

¹ Output A3 is only used when the O₂ sensor option is installed

See Figure 3-2 for the location of the analog output connector on the instrument's rear panel.

6.13.4.1. Analog Output Signal Type and Range Span Selection

To select an output signal type (DC Voltage or current) and level for one output channel, activate the ANALOG I/O CONFIGURATION MENU (See Section 6.13.1) then press:

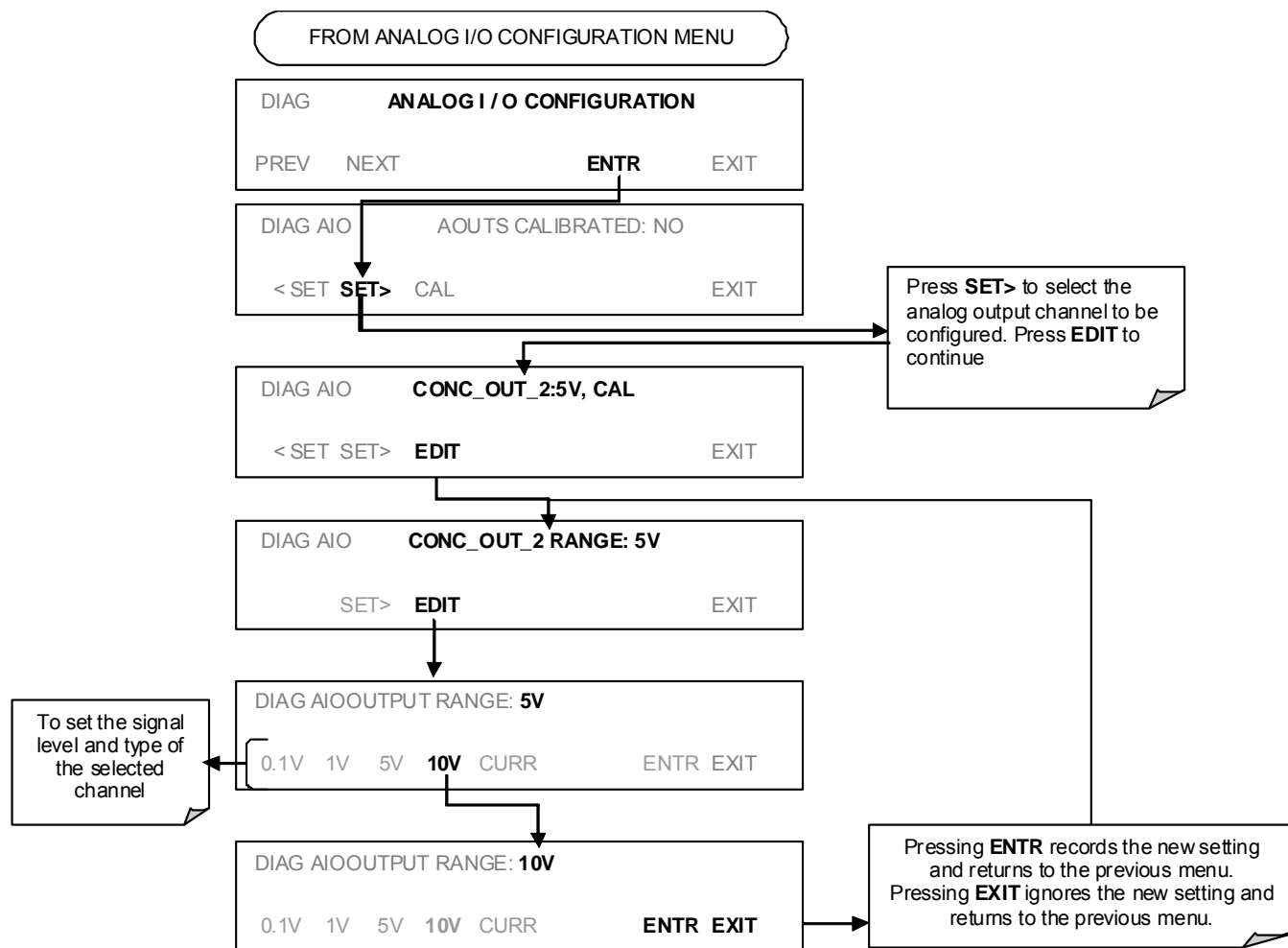

6.13.4.2. Analog Output Calibration Mode

The analog outputs can be calibrated automatically or manually. In its default mode, the instrument is configured for automatic calibration of all channels. Manual calibration should be used for the 0.1V range or in cases where the outputs must be closely matched to the characteristics of the recording device. Outputs configured for automatic calibration can be calibrated as a group or individually. Calibration of the analog outputs needs to be carried out on first startup of the analyzer (performed in the factory as part of the configuration process) or whenever re-calibration is required.

To calibrate the outputs as a group, activate the ANALOG I/O CONFIGURATION MENU (See Section 6.13.1), then press:

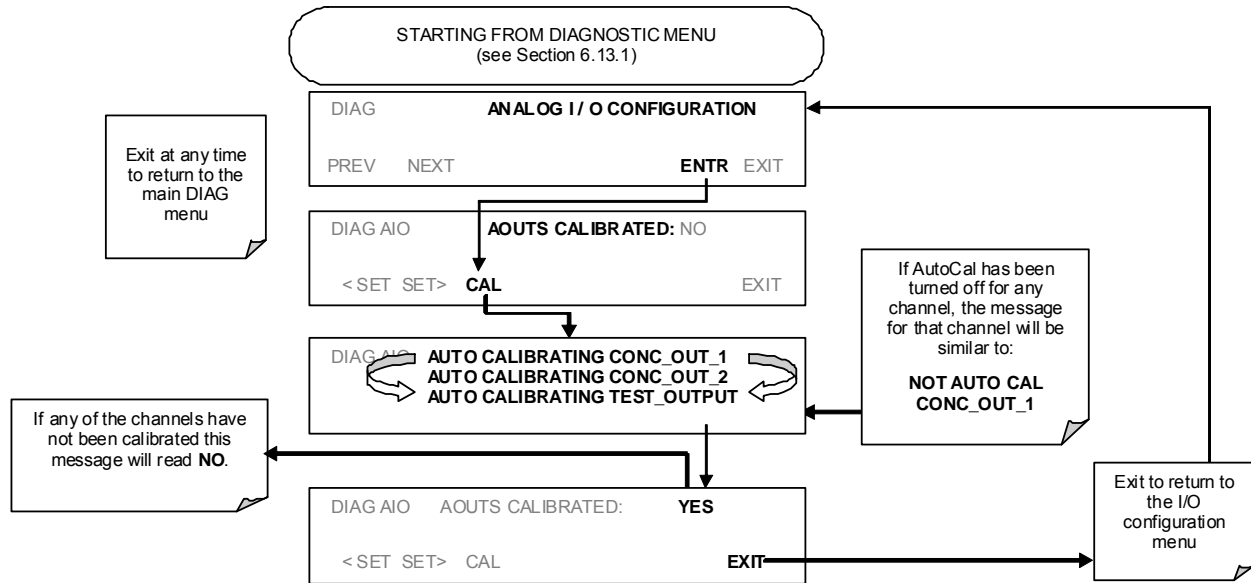

To automatically calibrate a single analog channel, activate the ANALOG I/O CONFIGURATION MENU (See Section 6.13.1), then press:

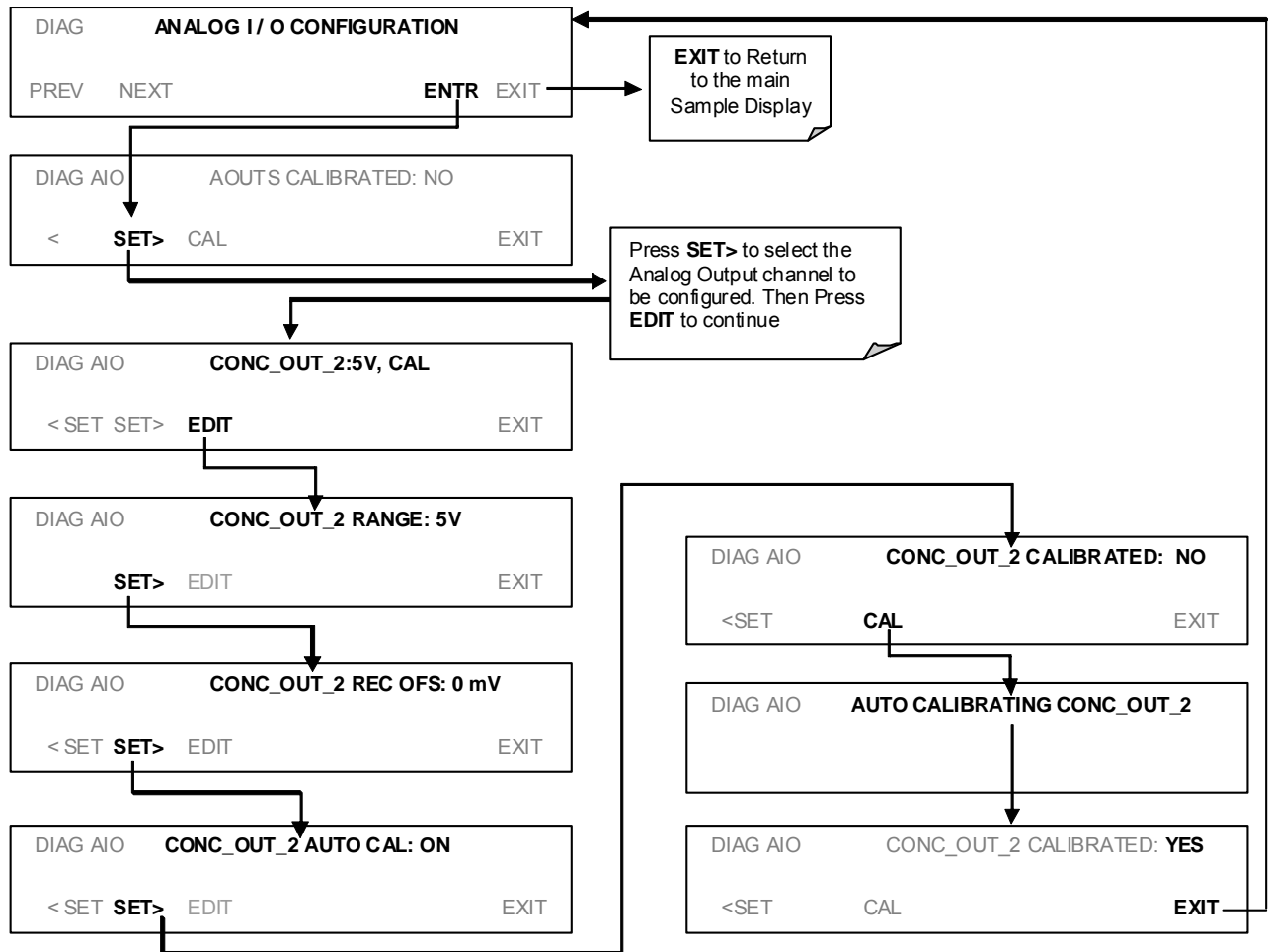

To select manual output calibration for a particular channel, activate the ANALOG I/O CONFIGURATION MENU (See Section 6.13.1), then press:

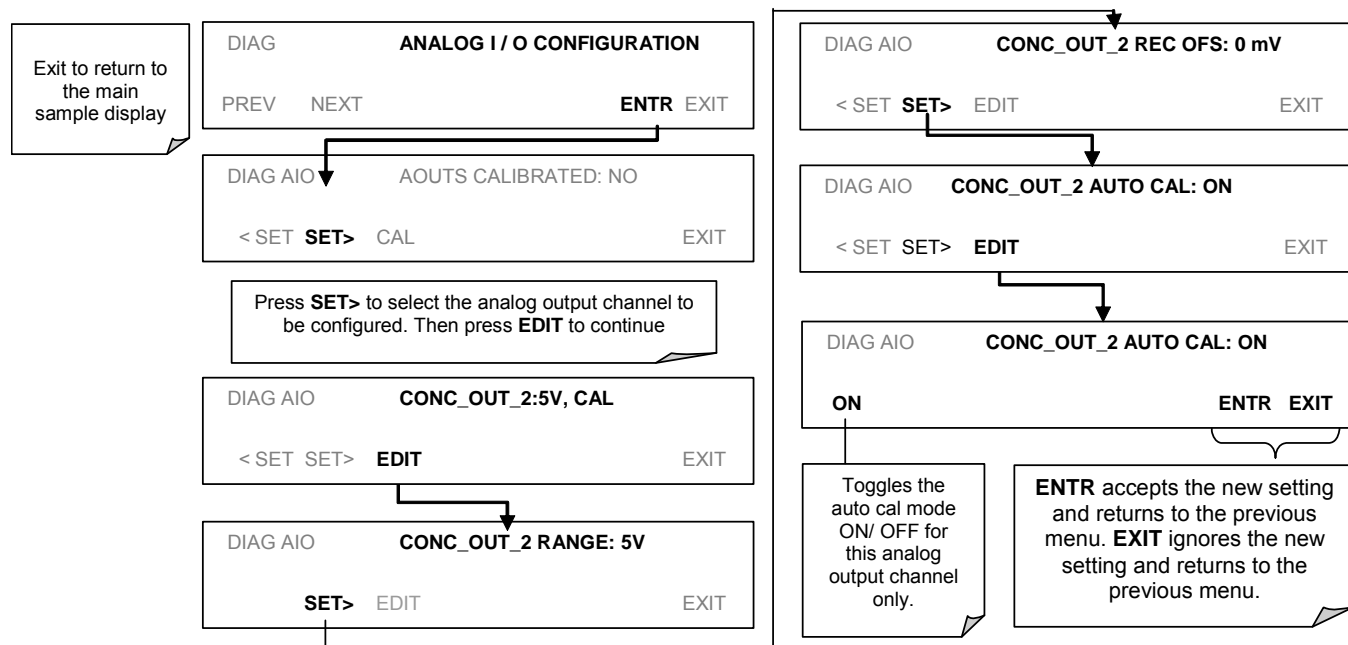

Now the analog output channels should either be automatically calibrated or they should be set to manual calibration, which is described next.

6.13.4.3. Manual Analog Output Calibration and Voltage Adjustment

For highest accuracy, the voltages of the analog outputs can be manually calibrated. Calibration is done through the instrument software with a voltmeter connected across the output terminals (Figure 6-15). Adjustments are made using the touchscreen buttons by setting the zero-point first and then the span-point (Table 6-20).

The software allows this adjustment to be made in 100, 10 or 1 count increments.

Table 6-20: Voltage Tolerances for Analog Output Calibration

Full Scale	Zero Tolerance	Span Voltage	Span Tolerance
0.1 VDC	±0.0005V	90 mV	±0.001V
1 VDC	±0.001V	900 mV	±0.001V
5 VDC	±0.002V	4500 mV	±0.003V
10 VDC	±0.004V	4500 mV	±0.006V

NOTE

Outputs configured for 0.1V full scale should always be calibrated manually

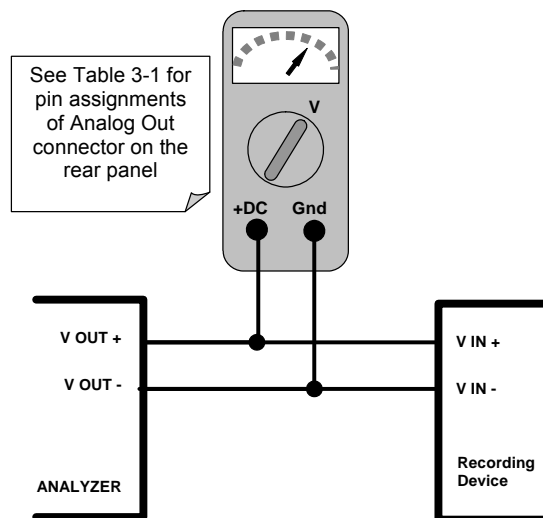
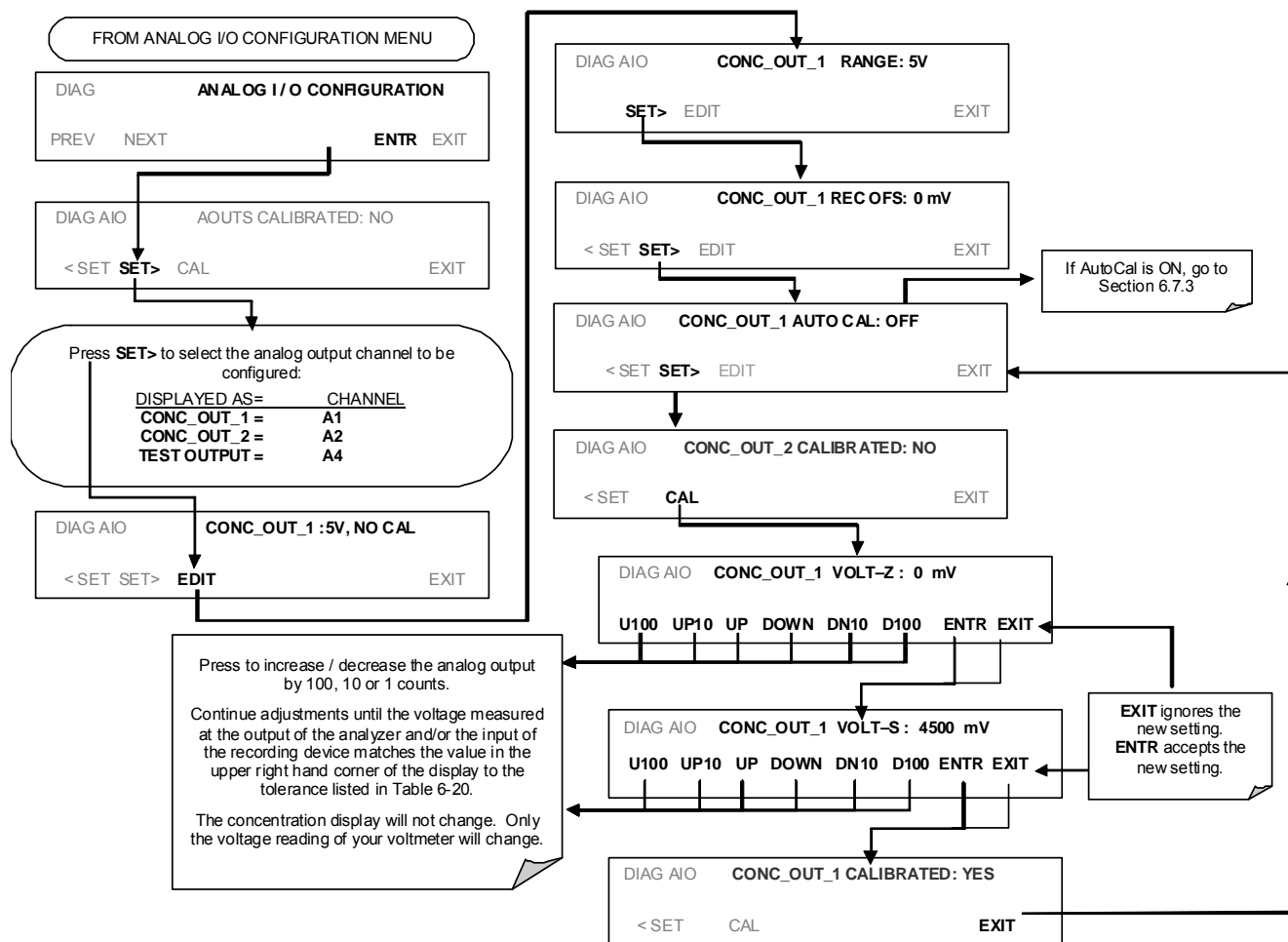

Figure 6-11: Setup for Calibrating Analog Voltage Outputs

To make these adjustments, the AOUT auto-calibration feature must be turned off (Section 6.13.4.2). Activate the ANALOG I/O CONFIGURATION MENU (See Section 6.13.1), then press:



6.13.4.4. Current Loop Output Adjustment

A current loop option is available and can be installed as a retrofit for each of the analog outputs of the analyzer (s 5.2). This option converts the DC voltage analog output to a current signal with 0-20 mA output current. The outputs can be scaled to any set of limits within that 0-20 mA range. However, most current loop applications call for either 2-20 mA or 4-20 mA range. All current loop outputs have a +5% over-range. Ranges with the lower limit set to more than 1 mA (e.g., 2-20 or 4-20 mA) also have a -5% under-range.

To switch an analog output from voltage to current loop after installing the current output printed circuit assembly, follow the instructions in Section 6.13.4.4 and select CURR from the list of options on the RANGE menu.

Adjusting the signal zero and span values of the current loop output is done by raising or lowering the voltage of the respective analog output. This proportionally raises or lowers the current produced by the current loop option.

Similar to the voltage calibration, the software allows this current adjustment to be made in 100, 10 or 1 count increments. Since the exact current increment per voltage count varies from output to output and from instrument to instrument, you will need to measure the change in the current with a current meter placed in series with the output circuit (Figure 6-16).

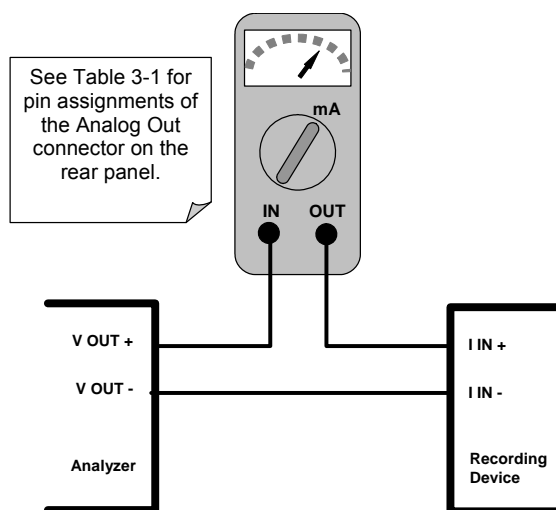
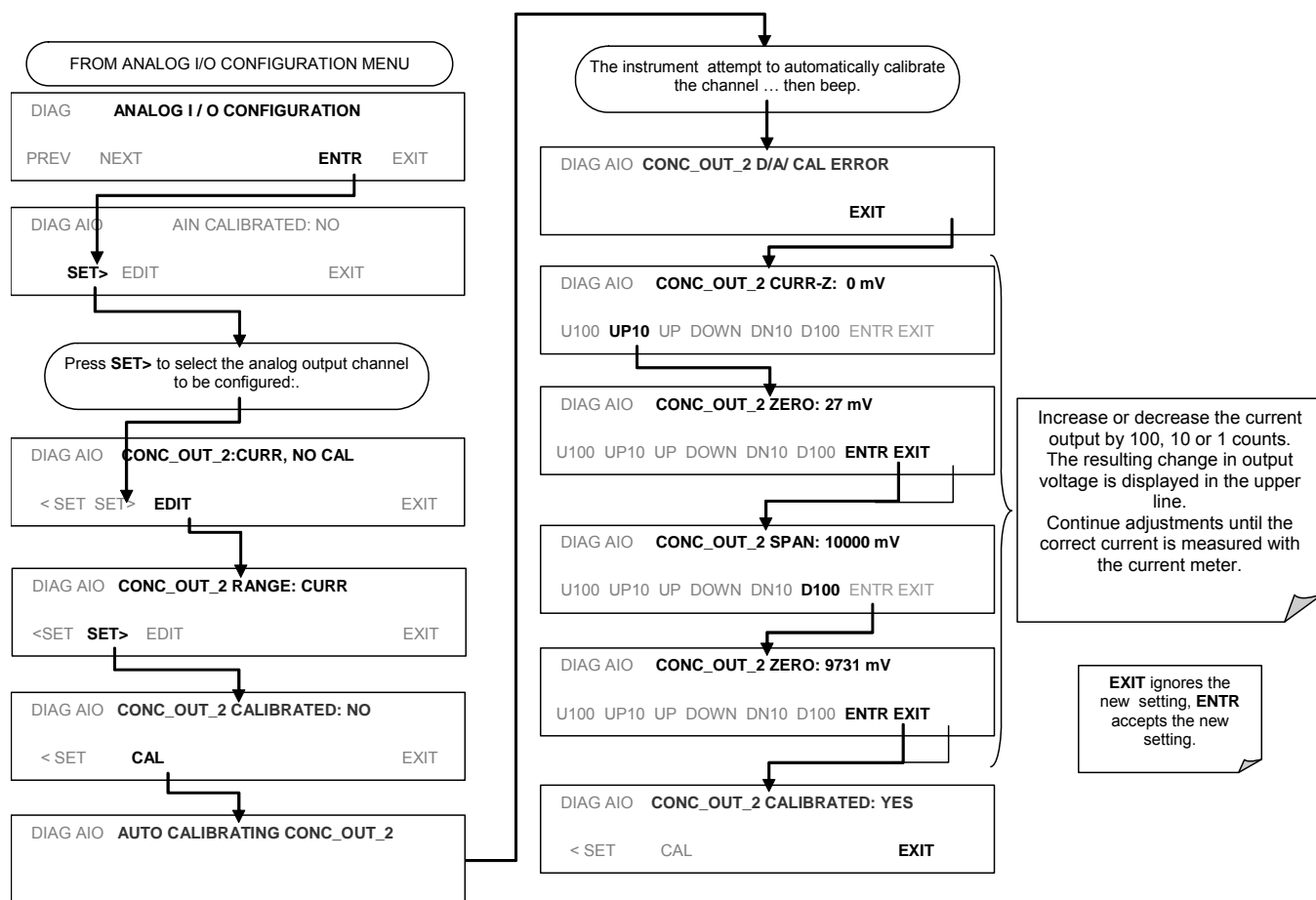

Figure 6-12: Setup for Calibrating Current Outputs

NOTE

Do not exceed 60 V between current loop outputs and instrument ground.

To adjust the zero and span values of the current outputs, activate the ANALOG I/O CONFIGURATION MENU (See Section 6.13.1), then press:



If a current meter is not available, an alternative method for calibrating the current loop outputs is to connect a $250 \Omega \pm 1\%$ resistor across the current loop output. Using a voltmeter connected across the resistor, follow the procedure above but adjust the output to the following values:

Table 6-21: Current Loop Output Calibration with Resistor

Full scale	Voltage for 2-20 mA (measured across resistor)	Voltage for 4-20 mA (measured across resistor)
0%	0.5 V	1.0 V
100%	5.0 V	5.0 V

6.13.4.5. AIN Calibration

This is the sub-menu to conduct the analog input calibration. This calibration should only be necessary after major repair such as a replacement of CPU, motherboard or power supplies. Activate the ANALOG I/O CONFIGURATION MENU (See Section 6.13.1), then press:

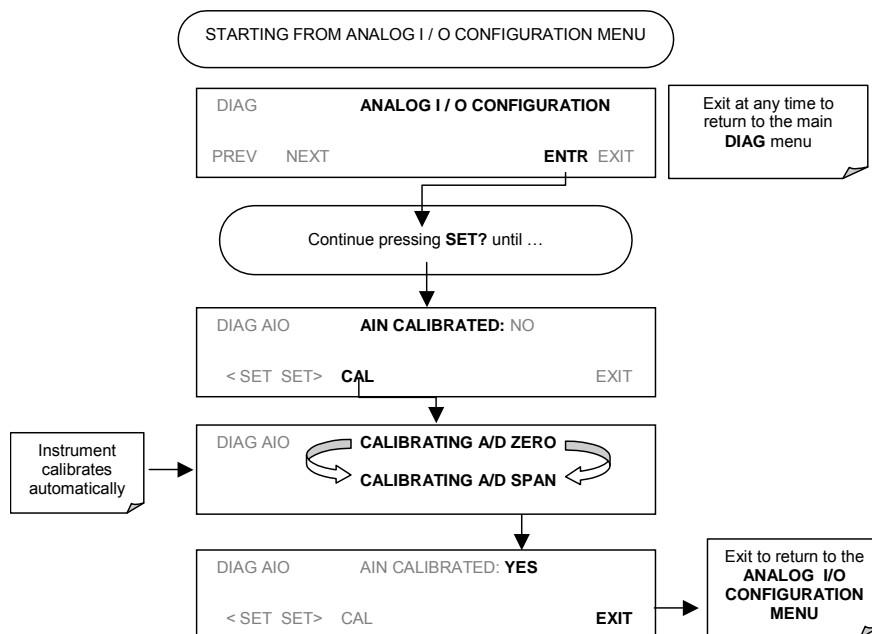

6.13.4.6. Configuring Analog Inputs (Option) Channels

To configure the analyzer's external analog inputs option, define for each channel:

- gain (number of units represented by 1 volt)
- offset (volts)
- engineering units to be represented in volts (each press of the touchscreen button scrolls the list of alphanumeric characters from A-Z and 0-9)
- whether to display the channel in the Test functions

To access and adjust settings for the external Analog Inputs option channels press:

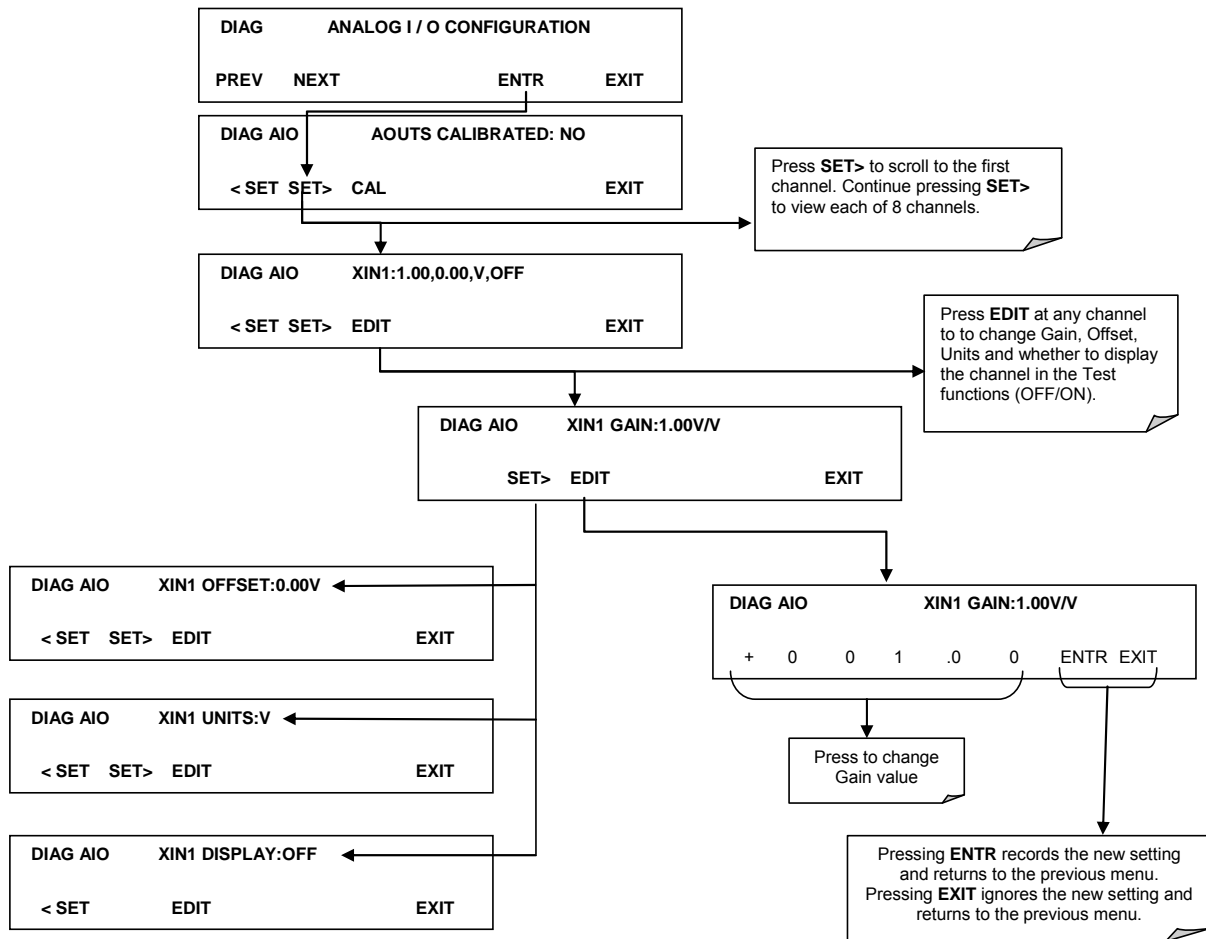

6.13.5. Electric Test

The electric test function substitutes simulated signals for **CO₂ MEAS** and **CO₂ REF**, generated by circuitry on the sync/demod board, for the output of the IR photo-detector. While in this mode the user can also view the same test functions viewable from the main **SAMPLE** display. When the test is running, the concentration reported on the front panel display should be **40.0** ppm.

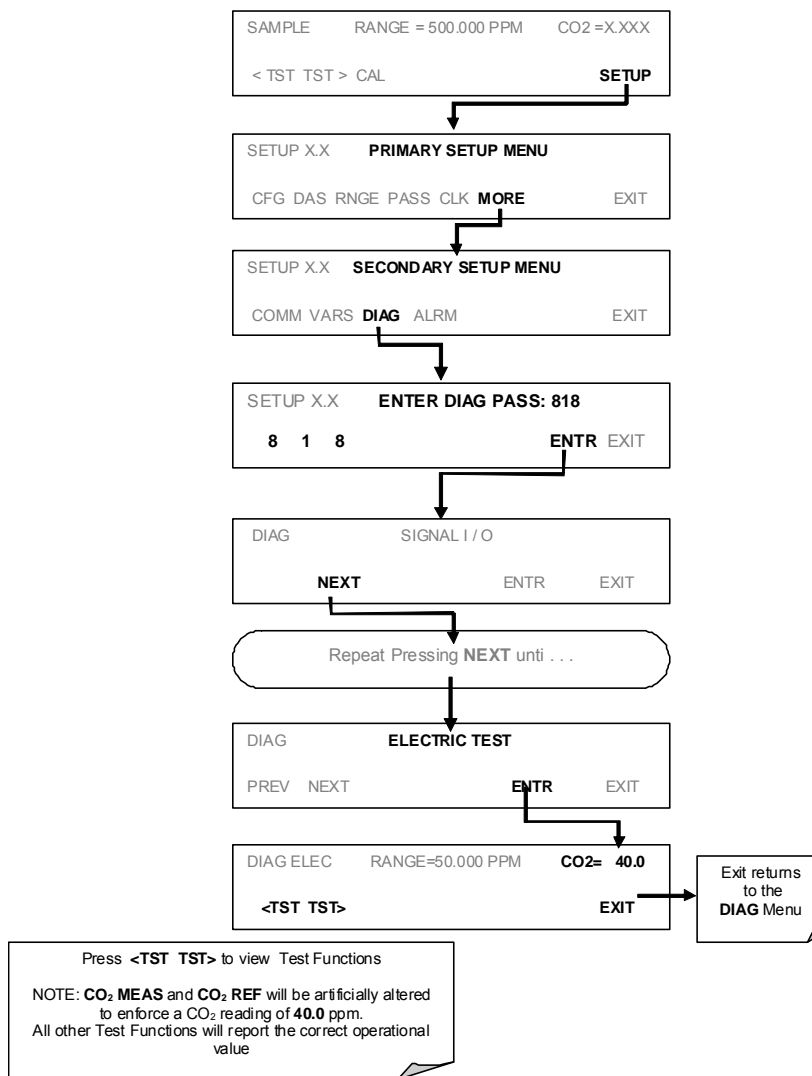

6.13.6. Dark Calibration Test

The dark calibration test interrupts the signal path between the IR photo-detector and the remainder of the sync/demod board circuitry. This allows the instrument to compensate for any voltage levels inherent in the sync/demod circuitry that might effect the calculation of CO₂ concentration. Performing this calibration returns two offset voltages, One for CO₂ MEAS and on for CO₂ REF that are automatically added to the CPU's calculation routine. The two offset voltages from the last calibration procedure may be reviewed by the user via the front panel display.

To activate the dark calibration procedure or review the results of a previous calibration, press:

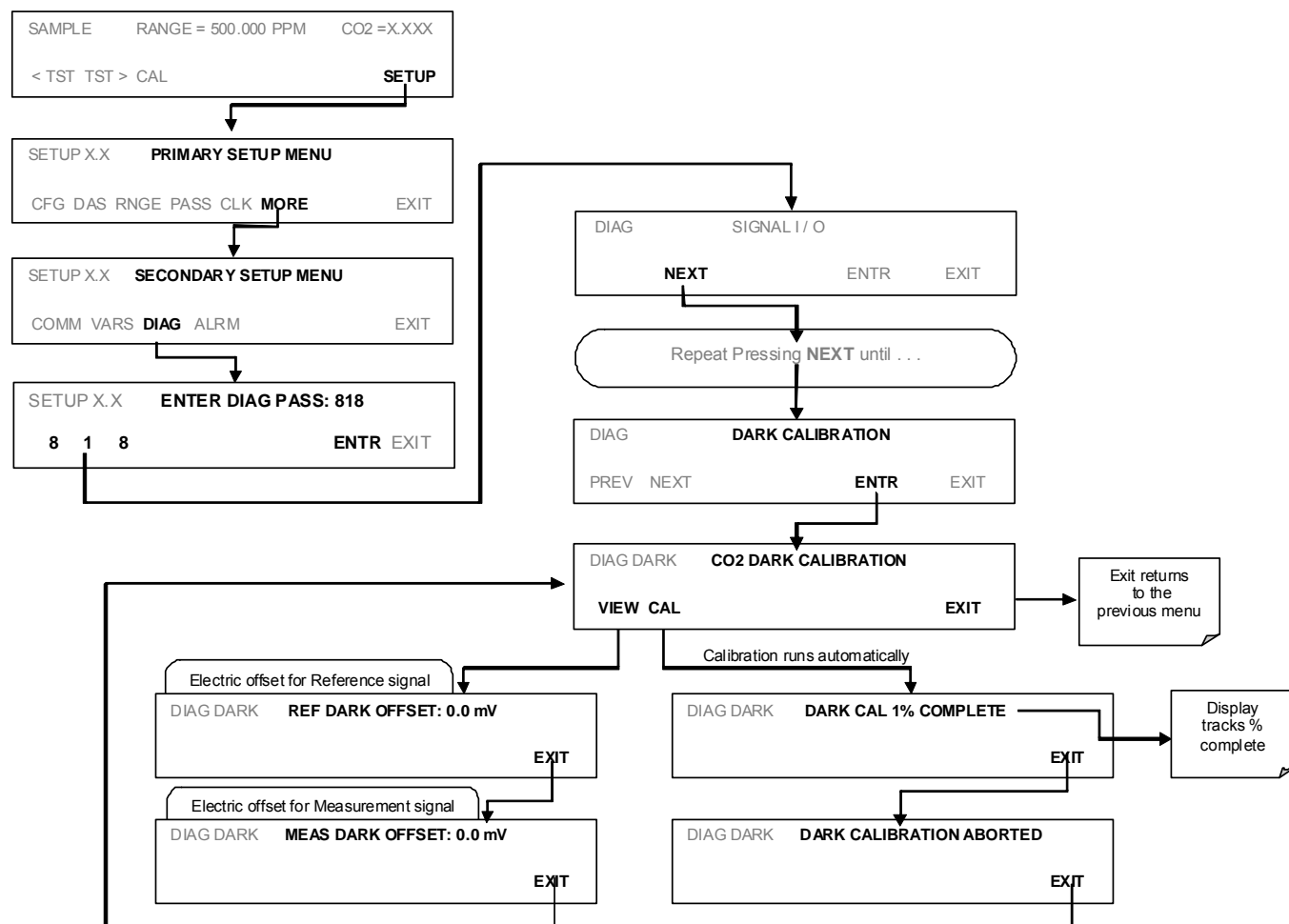

6.13.7. Pressure Calibration

A sensor at the exit of the sample chamber continuously measures the pressure of the sample gas. This data is used to compensate the final CO₂ concentration calculation for changes in atmospheric pressure and is stored in the CPU's memory as the test function **PRES** (also viewable via the front panel).

NOTE

This calibration must be performed when the pressure of the sample gas is equal to ambient atmospheric pressure.

If your instrument is equipped with a sample pump, disconnect the sample gas pump and the sample gas-line vent from the sample gas inlet on the instrument's rear panel before performing the following pressure calibration procedure.

To cause the analyzer to measure and record a value for **PRES**, press.

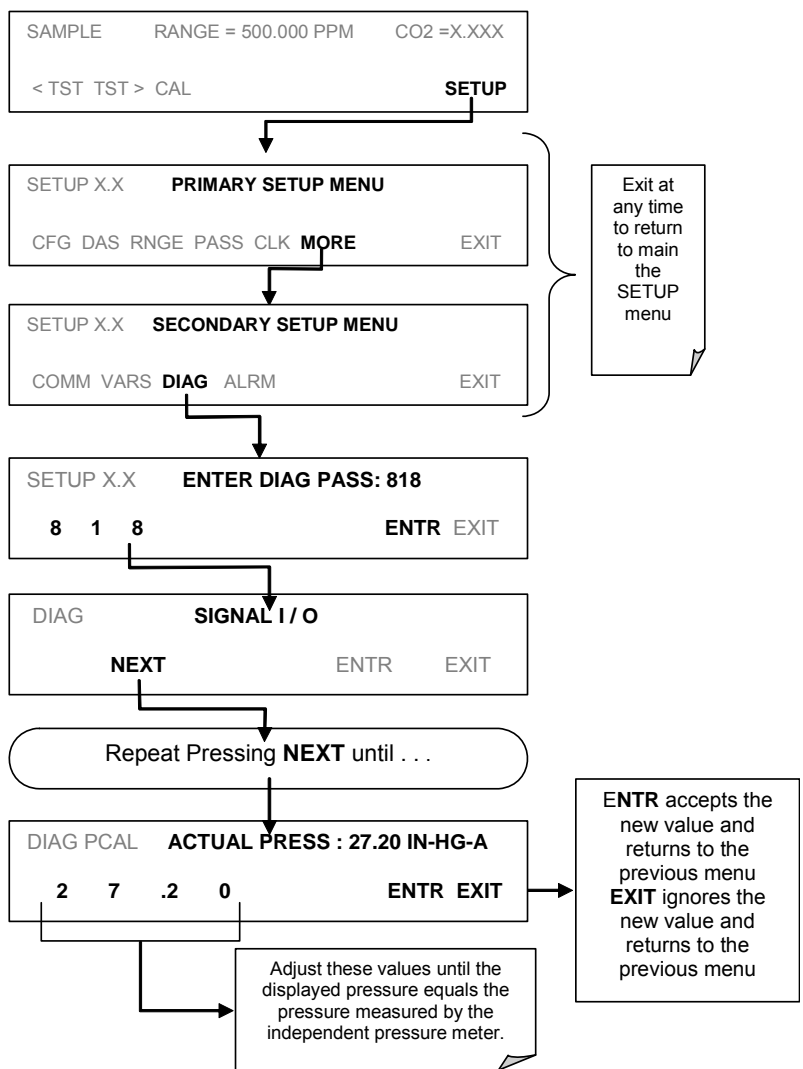

6.13.8. Flow Calibration

The flow calibration allows the user to adjust the values of the sample flow rates as they are displayed on the front panel and reported through COM ports to match the actual flow rate measured at the sample inlet. This does not change the hardware measurement of the flow sensors, only the software calculated values.

To carry out this adjustment, connect an external, sufficiently accurate flow meter to the sample inlet (see Section 11 for more details). Once the flow meter is attached and is measuring actual gas flow, press:

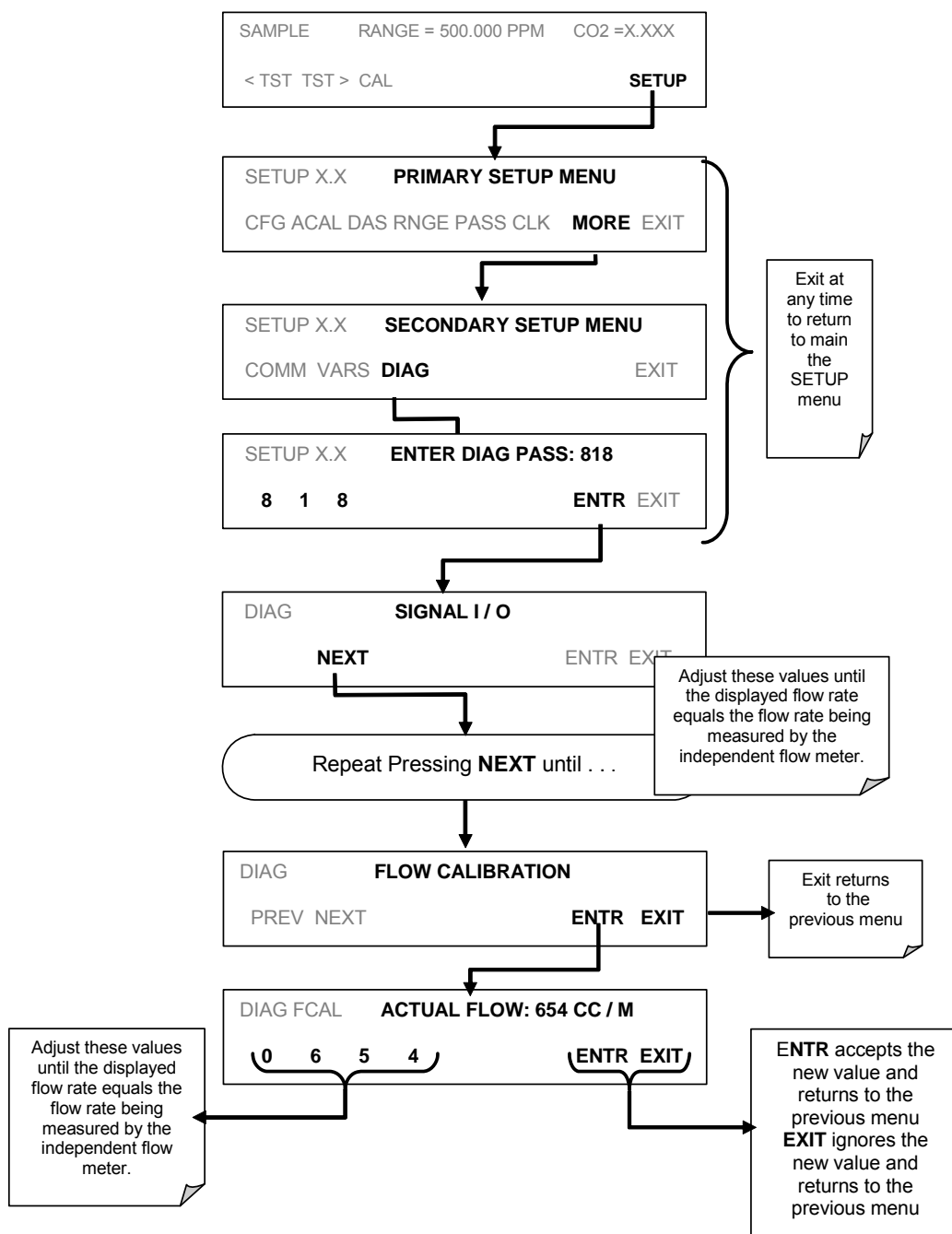

6.13.9. Test Channel Output

When activated, output channel **A4** can be used to report one of the test functions viewable from the **SAMPLE** mode display. To activate the **A4** channel and select a test function, follow this button sequence:

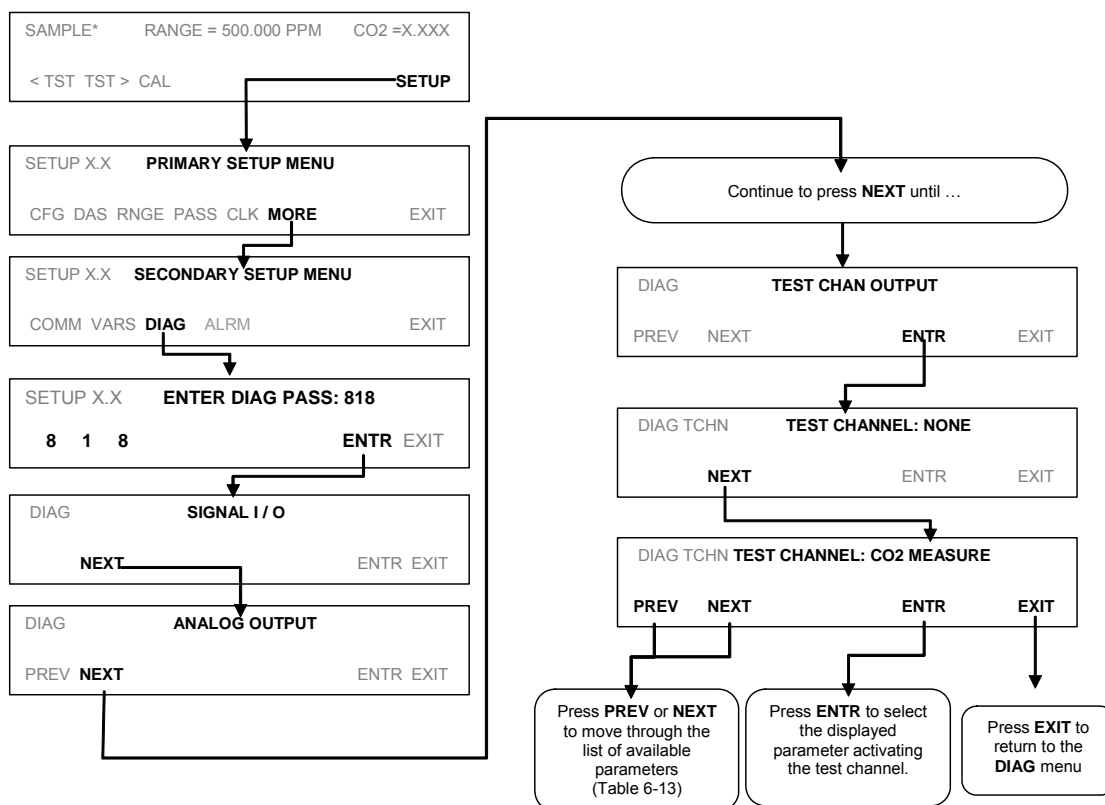

Table 6-22: Test Parameters Available for Analog Output A4

TEST CHANNEL	ZERO	FULL SCALE
NONE	Test Channel is turned off	
CO ₂ MEASURE	0 mV	5000 mV*
CO ₂ REFERENCE	0 mV	5000 mV*
SAMPLE PRESS	0 "Hg	40 "Hg
SAMPLE FLOW	0 cc/m	1000 cc/m
SAMPLE TEMP	0°C	70°C
BENCH TEMP	0°C	70°C
WHEEL TEMP	0°C	70°C
CHASSIS TEMP	0°C	70°C
PHT DRIVE	0 mV	5000 mV

* This refers to the internal voltage level of the function NOT the output signal level of the Test channel itself.

6.14. SETUP → MORE → ALRM: Using the Gas Concentration Alarms

There are 4 relay alarm outputs (AL1-AL4) on the rear panel.

- AL1 is for “system okay”,
- AL2 is for “high range status” and
- AL3 is for “zero calibration status”
- AL4 is not used

In the standard configuration, the AL1 relay is energized when the system is okay and de-energized when the system has a fault. The AL2 relay is energized when the high auto-range is in use and AL3 relays energize when the the instrument is in zero calibration mode.

The Model GFC 7000T includes two CO₂ concentration alarms. Each alarm has a user settable limit, and is associated with an opto-isolated TTL relay accessible via the status output connector on the instrument’s back panel (See Section 6.15.1.1). If the CO₂ concentration measured by the instrument rises above that limit, the alarm’s status output relay is closed.

The default settings for **ALM1** and **ALM2** are:

Table 6-23: CO₂ Concentration Alarm Default Settings

ALARM	STATUS	LIMIT SET POINT ¹
ALM1	Disabled	100 ppm
ALM2	Disabled	300 ppm

¹Set points listed are for PPM. Should the reporting range units of measure be changed (See Section 6.7.6) the analyzer will automatically scale the set points to match the new range unit setting.

Note

To prevent the concentration alarms from activating during span calibration operations make sure to press CAL or CALS button prior to introducing span gas into the analyzer.

6.14.1. Setting the Concentration Alarm Limits

To enable either of the CO₂ concentration alarms and set the Limit points, press:

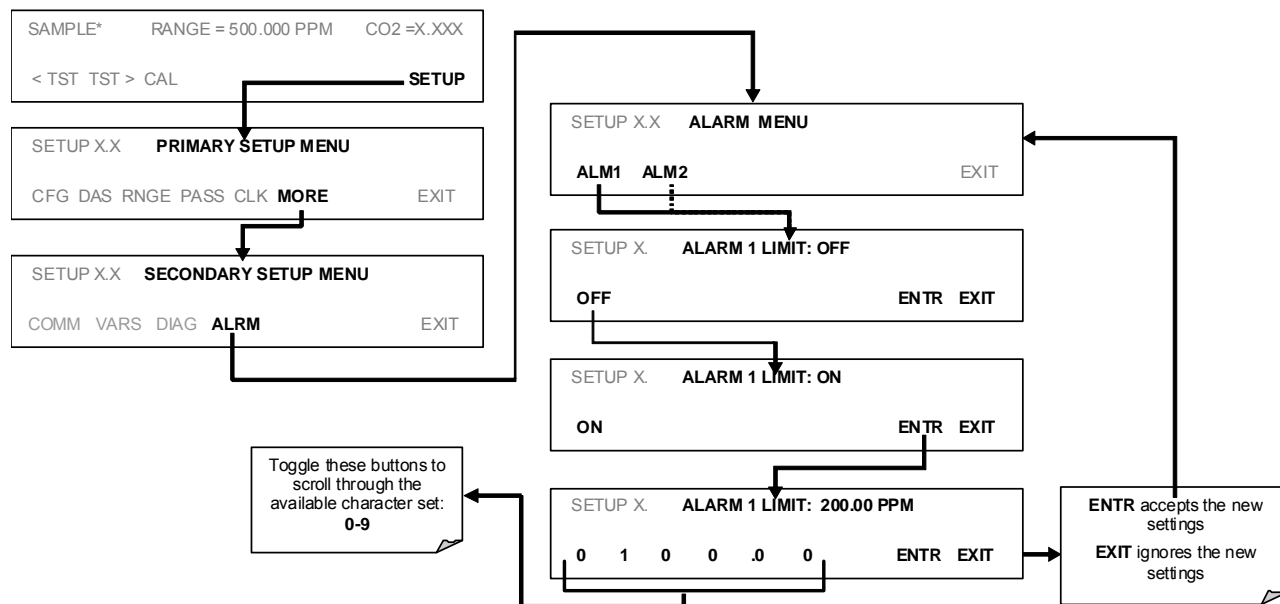

6.15. Remote Operation of the Analyzer

6.15.1. Remote Operation Using the External Digital I/O

6.15.1.1. Status Outputs

The status outputs report analyzer conditions via optically isolated NPN transistors, which sink up to 50 mA of DC current. These outputs can be used interface with devices that accept logic-level digital inputs, such as programmable logic controllers (PLC's). Each Status bit is an open collector output that can withstand up to 40 VDC. All of the emitters of these transistors are tied together and available at D.

NOTE

Most PLC's have internal provisions for limiting the current that the input will draw from an external device. When connecting to a unit that does not have this feature, an external dropping resistor must be used to limit the current through the transistor output to less than 50 mA. At 50 mA, the transistor will drop approximately 1.2V from its collector to emitter.

The status outputs are accessed via a 12-pin connector on the analyzer's rear panel labeled STATUS. The function of each pin is defined in Table 6-24.

STATUS

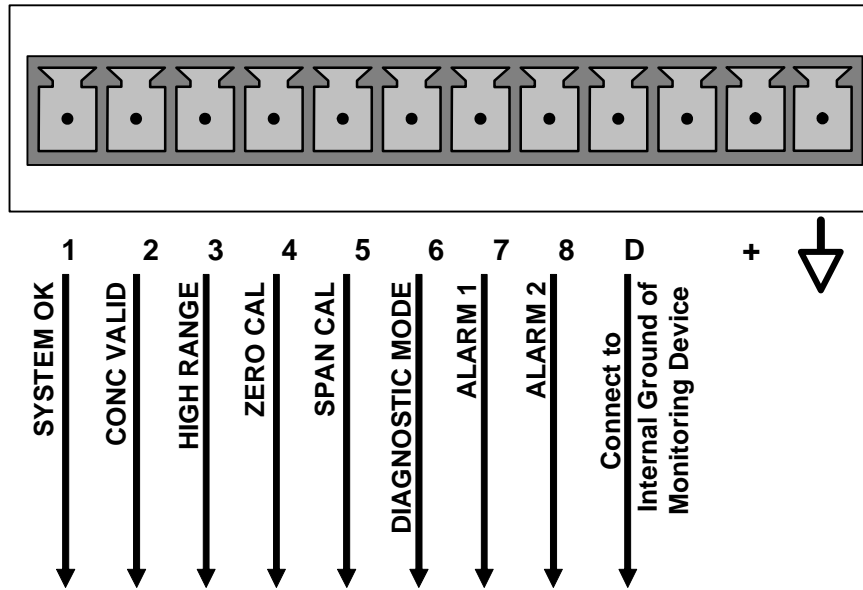



Figure 6-13: Status Output Connector

The pin assignments for the Status Outputs are:

Table 6-24: Status Output Pin Assignments

OUTPUT #	Status Definition	Condition
1	SYSTEM OK	On if no faults are present.
2	CONC VALID	On if CO ₂ concentration measurement is valid. If the CO ₂ concentration measurement is invalid, this bit is OFF.
3	HIGH RANGE	On if unit is in high range of DUAL or AUTO range modes.
4	ZERO CAL	On whenever the instruments zero point is being calibrated.
5	SPAN CAL	On whenever the instruments span point is being calibrated.
6	DIAG MODE	On whenever the instrument is in diagnostic mode.
7	ALARM1	On whenever the measured CO ₂ concentration is above the set point for ALM1
8	ALARM2	On whenever the measured CO ₂ concentration is above the set point for ALM2
D	EMITTER BUS	The emitters of the transistors on pins 1-8 are bused together.
+	DC POWER	+ 5 VDC
	Digital Ground	The ground level from the analyzer's internal DC power supplies.

6.15.1.2. Control Inputs

These inputs allow the user to remotely initiate Zero and Span calibrations. Two methods for energizing the inputs is provided below; the first using the internal +5V available on the CONTROL IN connector and the second, if an external, isolated supply is employed.

Table 6-25: Control Input Pin Assignments

INPUT	STATUS	CONDITION WHEN ENABLED
A	EXTERNAL ZERO CAL	Zero calibration mode is activated. The mode field of the display will read ZERO CAL R.
B	EXTERNAL SPAN CAL	Span calibration mode is activated. The mode field of the display will read SPAN CAL R.
C		Unused
D		Unused
E		Unused
F		Unused
↓	DIGITAL GROUND	Provided to ground an external device (e.g., recorder).
U	DC power for Input pull ups	Input for +5 VDC required to activate inputs A - F. This voltage can be taken from an external source or from the "+" pin.
+	Internal +5V Supply	Internal source of +5V which can be used to activate inputs when connected to pin U.

There are two methods to activate control inputs. The internal +5V available from the "+" pin is the most convenient method (Figure 6-18). However, to ensure that these inputs are truly isolated, a separate, external 5 VDC power supply should be used.

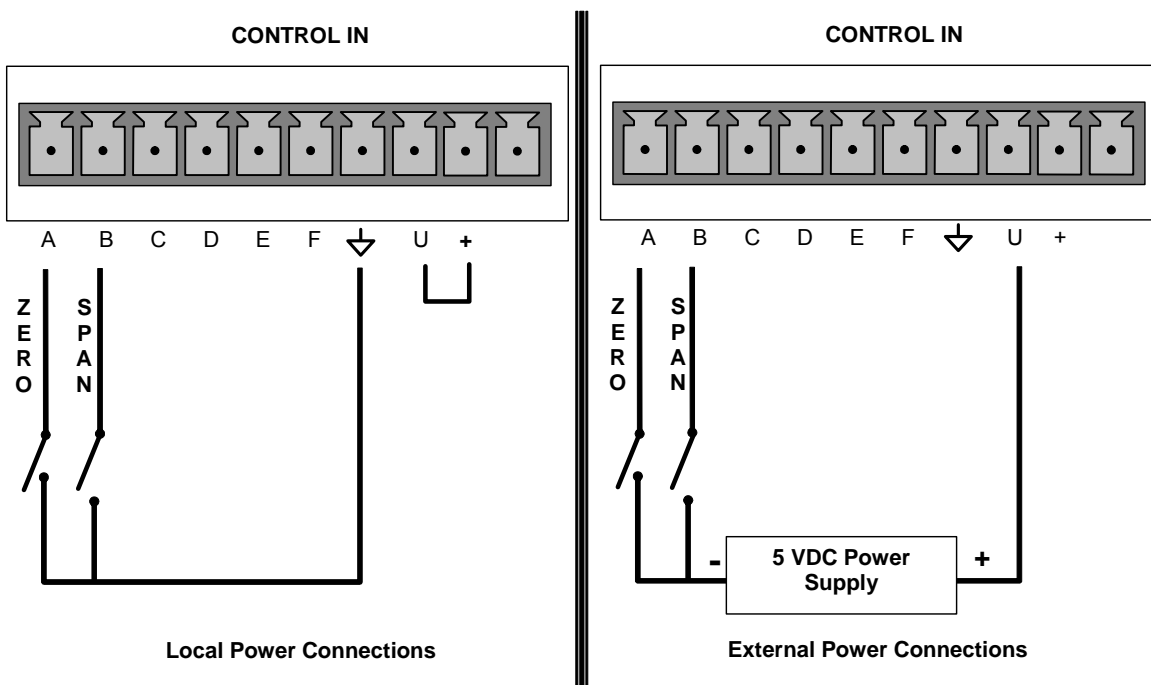

Figure 6-14: Control Inputs

6.15.2. Remote Operation Using the External Serial I/O

6.15.2.1. Terminal Operating Modes

The Model GFC 7000T can be remotely configured, calibrated or queried for stored data through the serial ports. As terminals and computers use different communication schemes, the analyzer supports two communicate modes specifically designed to interface with these two types of devices.

- **Computer mode** is used when the analyzer is connected to a computer with a dedicated interface program such as APICOM. More information regarding APICOM can be found in later in this or on the Teledyne Instruments website at <http://www.teledyne-api.com/software/apicom/>.
- **Interactive mode** is used with a terminal emulation programs such as HyperTerminal or a “dumb” computer terminal. The commands that are used to operate the analyzer in this mode are listed in Table 6-26.

6.15.2.2. Help Commands in Terminal Mode

Table 6-26: Terminal Mode Software Commands

COMMAND	Function
Control-T	Switches the analyzer to terminal mode (echo, edit). If mode flags 1 & 2 are OFF, the interface can be used in interactive mode with a terminal emulation program.
Control-C	Switches the analyzer to computer mode (no echo, no edit).
CR (carriage return)	A carriage return is required after each command line is typed into the terminal/computer. The command will not be sent to the analyzer to be executed until this is done. On personal computers, this is achieved by pressing the ENTER button.
BS (backspace)	Erases one character to the left of the cursor location.
ESC (escape)	Erases the entire command line.
? [ID] CR	This command prints a complete list of available commands along with the definitions of their functionality to the display device of the terminal or computer being used. The ID number of the analyzer is only necessary if multiple analyzers are on the same communications line, such as the multi-drop setup.
Control-C	Pauses the listing of commands.
Control-P	Restarts the listing of commands.



6.15.2.3. Command Syntax

Commands are not case-sensitive and all arguments within one command (i.e. ID numbers, keywords, data values, etc.) must be separated with a space character.

All Commands follow the syntax:

X [ID] COMMAND <CR>

Where

- X** is the command type (one letter) that defines the type of command. Allowed designators are listed in Table 6-27 and Appendix A-6.
- [ID]** is the analyzer identification number (Section 6.11.1.). Example: the Command “? 200” followed by a carriage return would print the list of available commands for the revision of software currently installed in the instrument assigned ID Number 200.
- COMMAND** is the command designator: This string is the name of the command being issued (LIST, ABORT, NAME, EXIT, etc.). Some commands may have additional arguments that define how the command is to be executed. Press ? <CR> or refer to Appendix A-6 for a list of available command designators.
- <CR>** is a carriage return. All commands must be terminated by a carriage return (usually achieved by pressing the ENTER button on a computer).

Table 6-27: Command Types

COMMAND	COMMAND TYPE
C	Calibration
D	Diagnostic
L	Logon
T	Test measurement
V	Variable
W	Warning

6.15.2.4. Data Types

Data types consist of integers, hexadecimal integers, floating-point numbers, Boolean expressions and text strings.

- Integer data are used to indicate integral quantities such as a number of records, a filter length, etc. They consist of an optional plus or minus sign, followed by one or more digits. For example, +1, -12, 123 are all valid integers.
- Hexadecimal integer data are used for the same purposes as integers. They consist of the two characters “0x,” followed by one or more hexadecimal digits (0-9, A-F, a-f), which is the ‘C’ programming language convention. No plus or minus sign is permitted. For example, 0x1, 0x12, 0x1234abcd are all valid hexadecimal integers.
- Floating point numbers are used to specify continuously variable values such as temperature set points, time intervals, warning limits, voltages, etc. They consist of an optional plus or minus sign,



followed by zero or more digits, an optional decimal point, and zero or more digits. (At least one digit must appear before or after the decimal point.) Scientific notation is not permitted. For example, *+1.0*, *1234.5678*, *-0.1*, *1* are all valid floating-point numbers.

- Boolean expressions are used to specify the value of variables or I/O signals that may assume only two values. They are denoted by the keywords *ON* and *OFF*.
- Text strings are used to represent data that cannot be easily represented by other data types, such as data channel names, which may contain letters and numbers. They consist of a quotation mark, followed by one or more printable characters, including spaces, letters, numbers, and symbols, and a final quotation mark. For example, *"a"*, *"1"*, *"123abc"*, and *"()[]<>"* are all valid text strings. It is not possible to include a quotation mark character within a text string.
- Some commands allow you to access variables, messages, and other items, such as DAS data channels, by name. When using these commands, you must type the entire name of the item; you cannot abbreviate any names.

6.15.2.5. Status Reporting

Reporting of status messages as an audit trail is one of the three principal uses for the RS-232 interface (the other two being the command line interface for controlling the instrument and the download of data in electronic format). You can effectively disable the reporting feature by setting the interface to quiet mode (Section 6.11.5., Table 6-10).

Status reports include DAS data (when reporting is enabled), warning messages, calibration and diagnostic status messages. Refer to Appendix A-3 for a list of the possible messages, and this for information on controlling the instrument through the RS-232 interface.

General Message Format

All messages from the instrument (including those in response to a command line request) are in the format:

X DDD:HH:MM [Id] MESSAGE<CRLF>

Where:

X	is a command type designator, a single character indicating the message type, as shown in the Table 6-27.
DDD:HH:MM	is the time stamp, the date and time when the message was issued. It consists of the Day-of-year (DDD) as a number from 1 to 366, the hour of the day (HH) as a number from 00 to 23, and the minute (MM) as a number from 00 to 59.
[ID]	is the analyzer ID, a number with 1 to 4 digits.
MESSAGE	is the message content that may contain warning messages, test measurements, DAS reports, variable values, etc.
<CRLF>	is a carriage return / line feed pair, which terminates the message.

The uniform nature of the output messages makes it easy for a host computer to parse them into an easy structure. Keep in mind that the front panel display does not give any information on the time a message was issued, hence it is useful to log such messages for trouble-shooting and reference purposes.

Terminal emulation programs such as HyperTerminal can capture these messages to text files for later review.

6.15.2.6. Remote Access by Modem

The GFC 7000T can be connected to a modem for remote access. This requires a cable between the analyzer's COM port and the modem, typically a DB-9F to DB-25M cable (available from Teledyne Instruments with part number WR0000024).

Once the cable has been connected, check to make sure the DTE-DCE is in the correct position. Also make sure the GFC 7000T COM port is set for a baud rate that is compatible with the modem, which needs to operate with an 8-bit word length with one stop bit.

The first step is to turn on the **MODEM ENABLE** communication mode (Mode 64, Section 6.11.5). Once this is completed, the appropriate setup command line for your modem can be entered into the analyzer. The default setting for this feature is

```
AT Y0 &D0 &H0 &I0 S0=2 &B0 &N6 &M0 E0 Q1 &W0
```

This string can be altered to match your modem's initialization and can be up to 100 characters long.

To change this setting press:

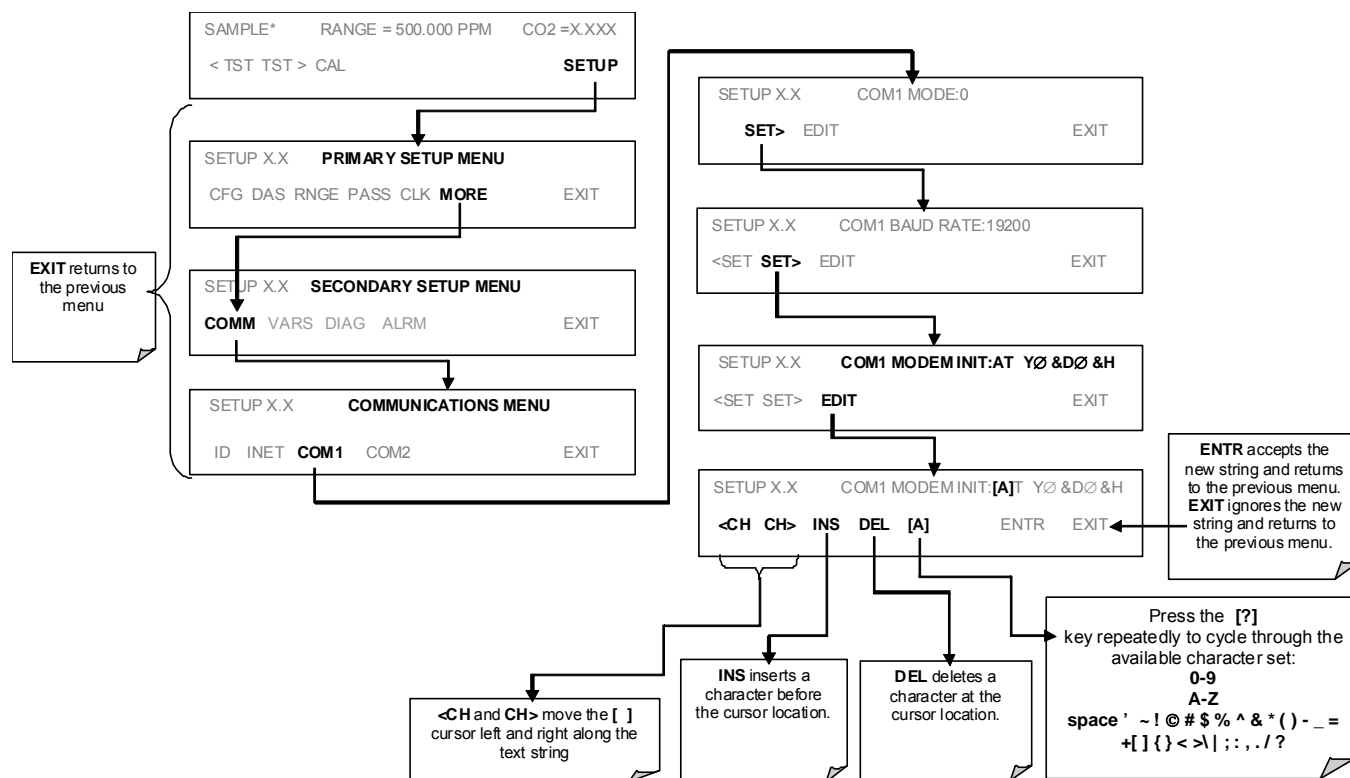

To initialize the modem press:

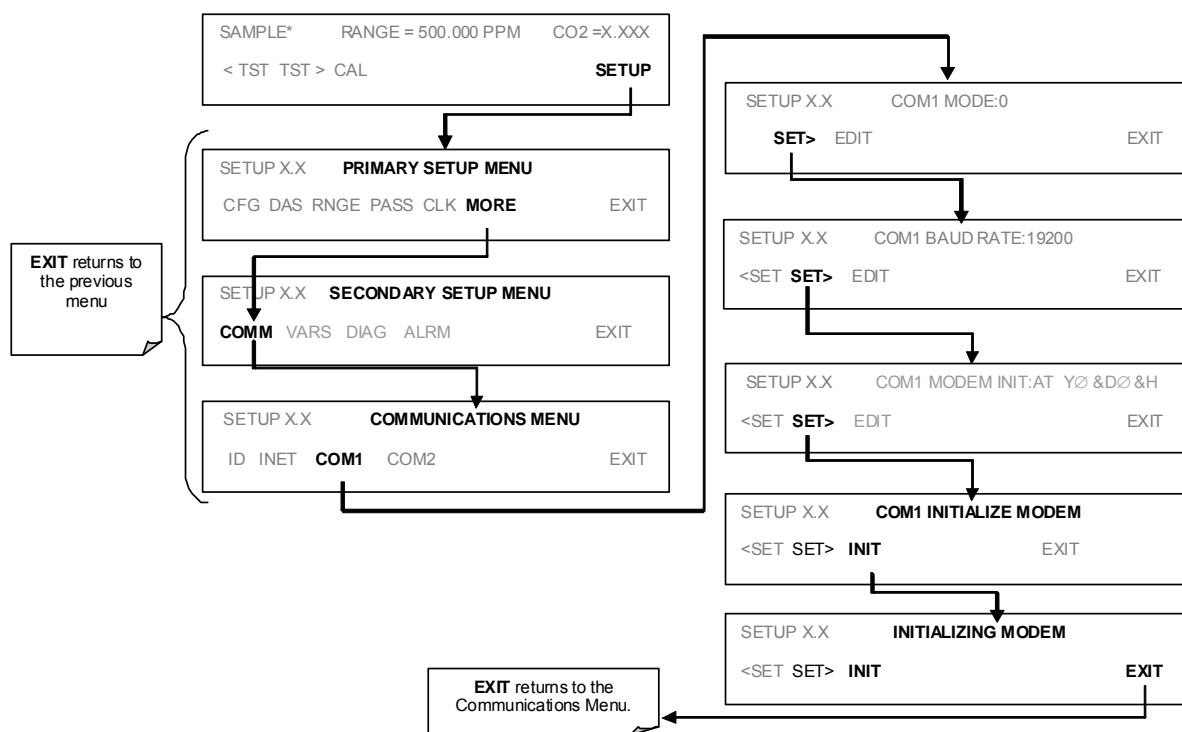

6.15.2.7. COM Port Password Security

In order to provide security for remote access of the GFC 7000T, a LOGON feature can be enabled to require a password before the instrument will accept commands. This is done by turning on the **SECURITY MODE** (Mode 4, Section 6.11.5). Once the **SECURITY MODE** is enabled, the following items apply.

- A password is required before the port will respond or pass on commands.
- If the port is inactive for one hour, it will automatically logoff, which can also be achieved with the LOGOFF command.
- Three unsuccessful attempts to log on with an incorrect password will cause subsequent logins to be disabled for 1 hour, even if the correct password is used.
- If not logged on, the only active command is the '?' request for the help screen.
- The following messages will be returned at logon:
 - LOGON SUCCESSFUL - Correct password given
 - LOGON FAILED - Password not given or incorrect
 - LOGOFF SUCCESSFUL - Connection terminated successfully

To log on to the Model GFC 7000T analyzer with **SECURITY MODE** feature enabled, type:

LOGON 940331

940331 is the default password. To change the default password, use the variable RS232_PASS issued as follows:

V RS232_PASS=NNNNNN

Where N is any numeral between 0 and 9.

6.15.2.8. APICOM Remote Control Program

APICOM is an easy-to-use, yet powerful interface program that allows accessing and controlling any of Teledyne Instruments' main line of ambient and stack-gas instruments from a remote connection through direct cable, modem or Ethernet. Running APICOM, a user can:

Establish a link from a remote location to the GFC 7000T through direct cable connection via RS-232 modem or Ethernet.

- View the instrument's front panel and remotely access all functions that could be accessed when standing in front of the instrument.
- Remotely edit system parameters and set points.
- Download, view, graph and save data for predictive diagnostics or data analysis.
- Retrieve, view, edit, save and upload DAS configurations.
- Check on system parameters for trouble-shooting and quality control.

APICOM is very helpful for initial setup, data analysis, maintenance and trouble-shooting. Figure 6-5 shows an example of APICOM being used to remotely configuration the instruments DAS feature. Figure 6-19 shows examples of APICOM's main interface, which emulates the look and functionality of the instruments actual front panel

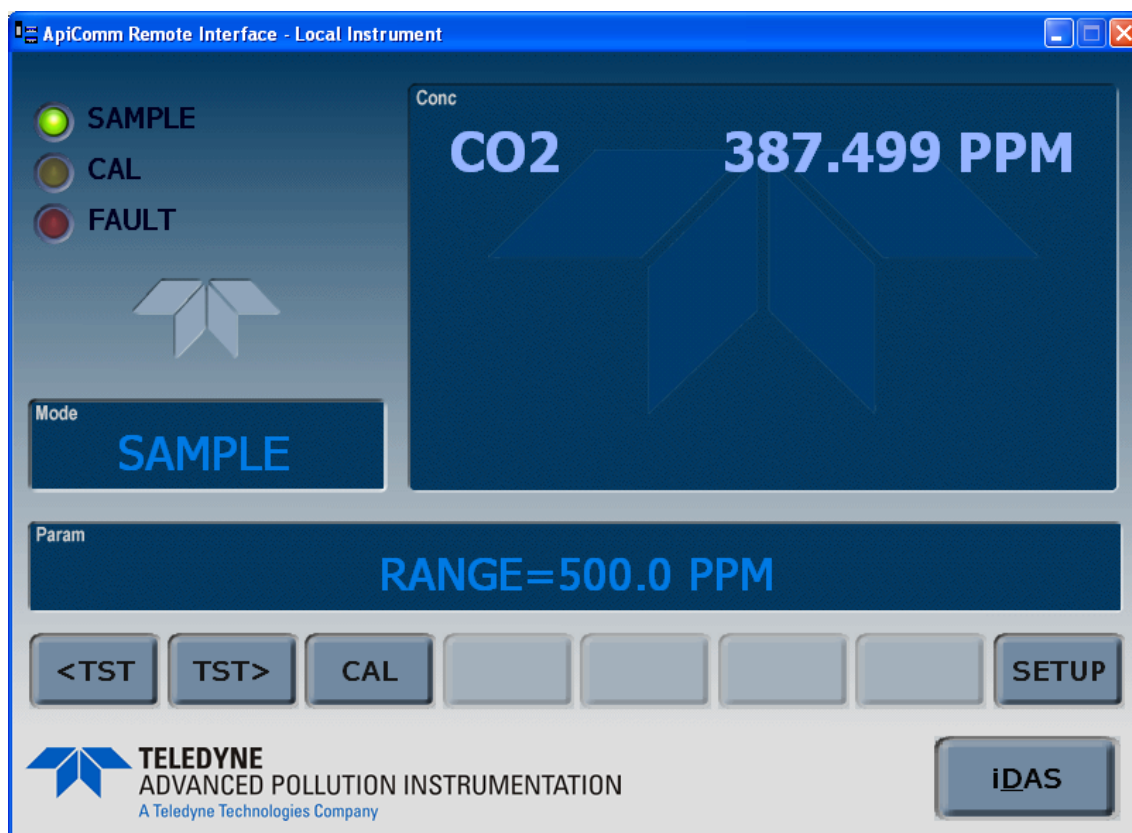

Figure 6-15: APICOM Remote Control Program Interface

APICOM is included free of cost with the analyzer and the latest versions can also be downloaded for free at <http://www.teledyne-api.com/software/apicom/>.



7. CALIBRATION PROCEDURES

This contains a variety of information regarding the various methods for calibrating a Model GFC 7000T CO₂ Analyzer as well as other supporting information.

NOTE

The procedures in this assume that the calibration password feature is disabled (the instruments default state). If it is enabled a password prompt screen (See Section 6.9) will appear after the CAL, CALZ or CALS buttons are pushed but before the instrument enters the associated calibration mode.

7.1. Before Calibration

The calibration procedures in this assume that the Range Type, Range Span and units of measure have already been selected for the analyzer. If this has not been done, please do so before continuing (See Section 6.8 for instructions).

All Gas lines should be PTFE (Teflon), FEP, glass, stainless steel or brass.

NOTE

If any problems occur while performing the following calibration procedures, refer to Section 11 of this manual for troubleshooting tips.

7.1.1. Zero Air and Span Gas

To perform the following calibration you must have sources for zero air and span gas available.

Zero Air is similar in chemical composition to the Earth's atmosphere but scrubbed of all components that might affect the analyzer's readings. Zero air should contain less than 25 ppb of CO₂ and other major interfering gases such as CO and Water Vapor. It should have a dew point of -5°C or less

Span Gas is a gas specifically mixed to match the chemical composition of the type of gas being measured at near full scale of the desired measurement range. It is recommended that the span gas used have a concentration equal to 80% of the full measurement range.

If Span Gas is sourced directly from a calibrated, pressurized tank, the gas mixture should be CO₂ mixed with Zero Air or N₂ at the required ratio.

Zero air generators that condition ambient air by drying and removal of pollutants are available on the commercial market such as the Teledyne Instruments Model 701 Zero Air Generator. We recommend this type of device, in conjunction with bottled N₂ for generating zero air.

7.1.2. Calibration Gas Traceability

All equipment used to produce calibration gases should be verified against standards of the National Institute for Standards and Technology (NIST). To ensure NIST traceability, we recommend acquiring cylinders of working gas that are certified to be traceable to NIST Standard Reference Materials (SRM). These are available from a variety of commercial sources.

7.1.3. Data Recording Devices

A strip chart recorder, data acquisition system or digital data acquisition system should be used to record data from the GFC 7000T's serial or analog outputs. If analog readings are used, the response of the recording system should be checked against a NIST traceable voltage source or meter. Data recording device should be capable of bi-polar operation so that negative readings can be recorded. For electronic data recording, the GFC 7000T provides an internal data acquisition system (DAS), which is described in detail in Section 6.7.

7.1.3.1. Input Pressure Limitation

This instrument has no significant internal restriction or adjustable valve to control/adjust flow. Calibration gas must be introduced to the inlet fitting at a fraction of a PSI above ambient pressure, just enough to drive the flow to the proper value range. Depending on the ultimate sample source pressure, a needle valve, restrictor, critical orifice or combination there should be deployed to achieve this. Do not directly apply significant pressure to the inlet of the unit under any circumstances, as damage / and or personal injury may result.

7.2. Manual Calibration without Zero/Span Valves

This is the basic method for manually calibrating the Model GFC 7000T CO₂ Analyzer without functioning zero/span valve options. It is identical to the method described in the GETTING STARTED (Section 3) of this manual and is repeated here for your convenience.

STEP ONE: Connect the Sources of Zero Air and Span Gas as shown below.



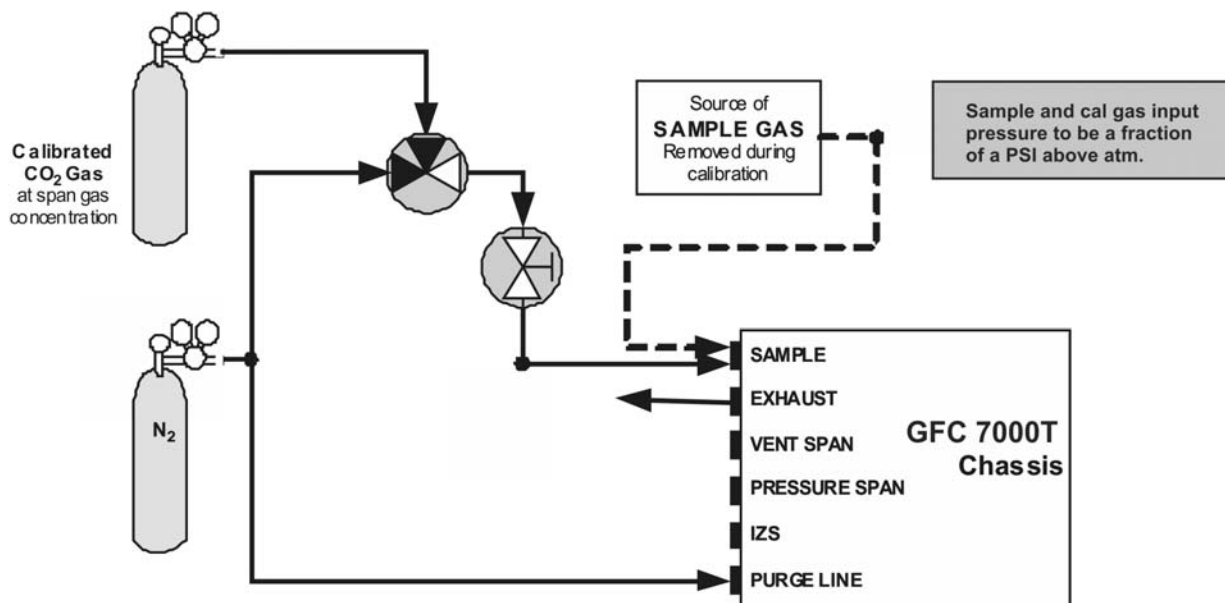

Figure 7-1: Pneumatic Connections—Basic Configuration—Using Bottled Span Gas

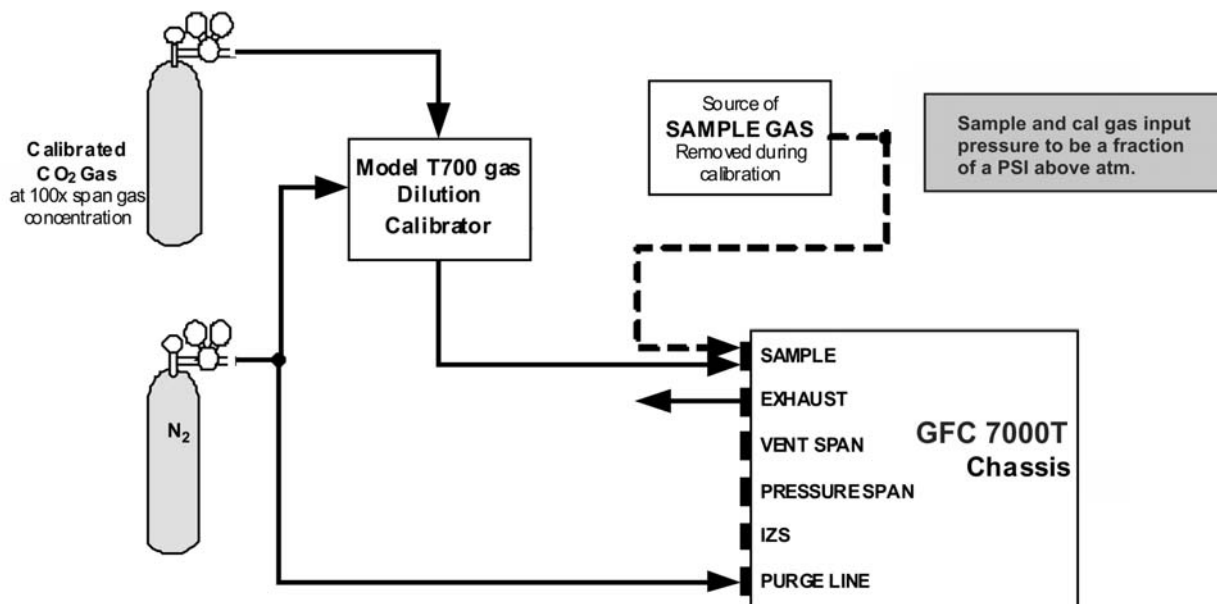
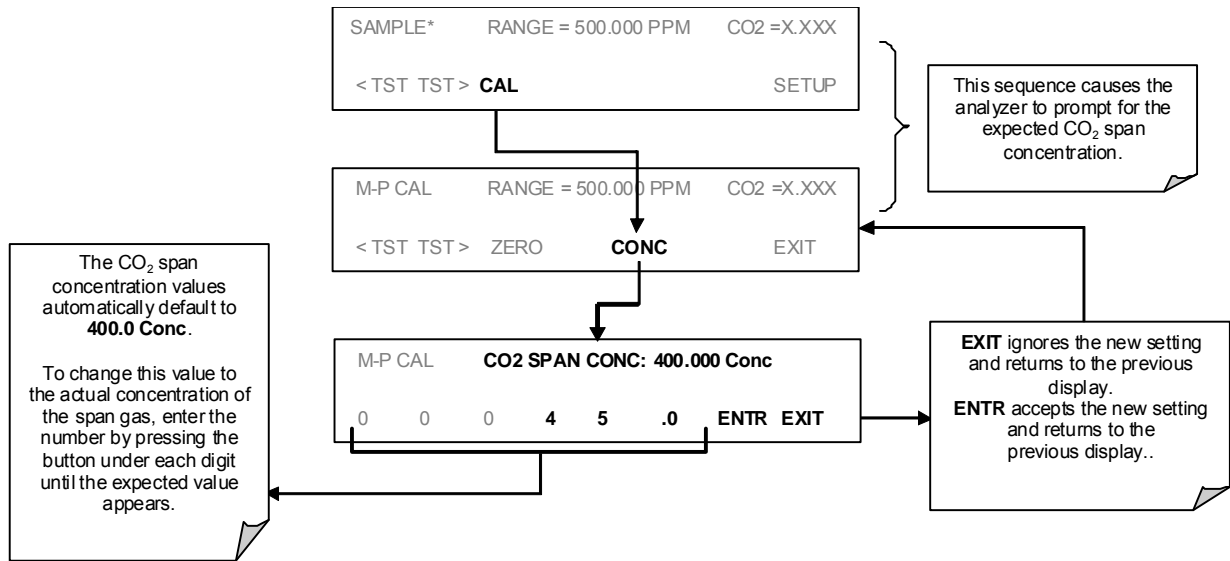

Figure 7-2: Pneumatic Connections—Basic Configuration—Using Gas Dilution Calibrator

STEP TWO: Set the expected CO₂ Span Gas concentration:



NOTE

For this Initial Calibration it is important to independently verify the PRECISE CO₂ Concentration Value of the SPAN gas.

If the source of the Span Gas is from a Calibrated Bottle, use the exact concentration value printed on the bottle.

STEP THREE: Perform the Zero/Span Calibration Procedure:

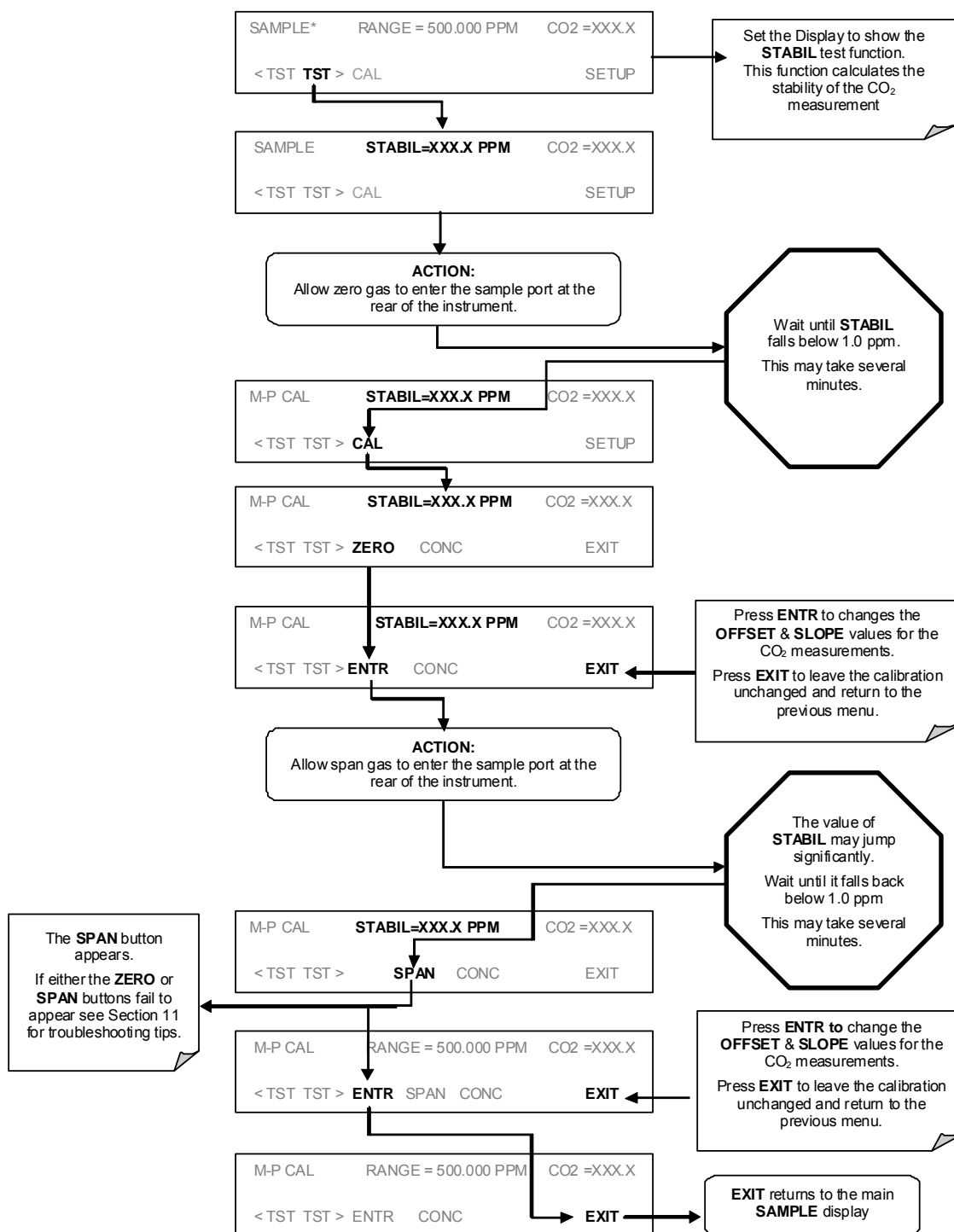

If the **ZERO** or **SPAN** buttons are not displayed, this means that the measurement made during that part of the procedure is too far out of the allowable range to do allow a reliable calibration. The reason for this must be determined before the analyzer can be calibrated. See Section 11 for troubleshooting tips.

7.3. Manual Calibration Checks

Informal calibration checks, which only evaluate but do not alter the analyzer’s response curve, are recommended as a regular maintenance item and in order to monitor the analyzer’s performance. To carry out a calibration check rather than a full calibration, follow these steps.

STEP ONE: Connect the sources of zero air and span gas as shown in Figures 7.1 or 7.2.

STEP TWO: Perform the zero/span calibration check procedure:

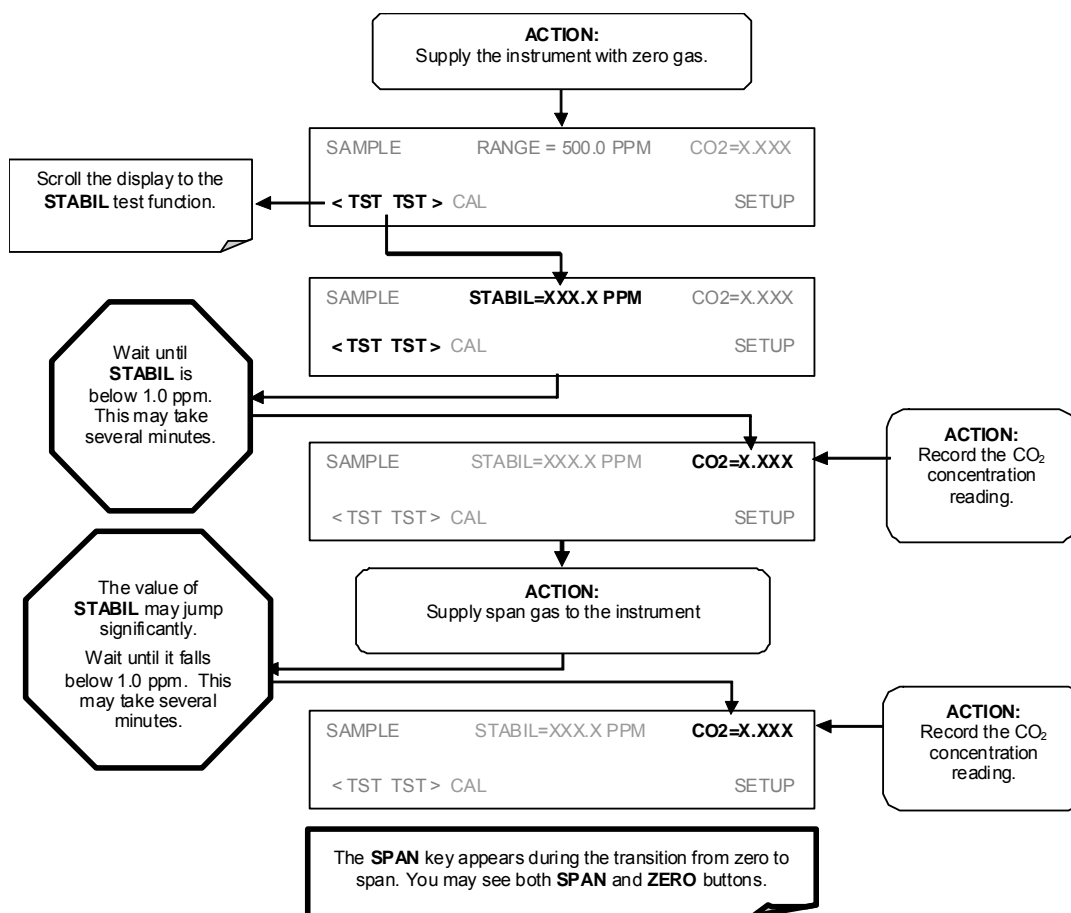

7.4. Manual Calibration with Zero/Span Valves

There are four different zero/span valve option configurations (See Section 5.4). They all operate identically, differing only in the method used to supply calibration gas to the Analyzer.

STEP ONE: Connect the sources of Zero Air and Span Gas as shown below.

Figure 7-3 shows the proper pneumatic connections for GFC 7000T with internal valve sets while Figure 7-4 adds the dilution calibrator and an external scrubber.

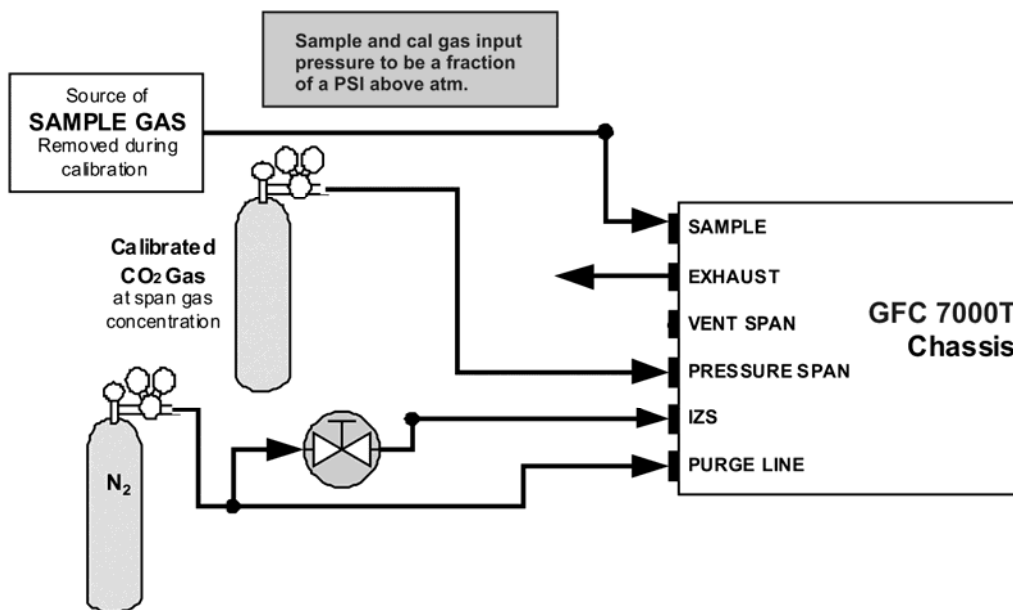

Figure 7-3: Pneumatic Connections – Zero/ Span Valves

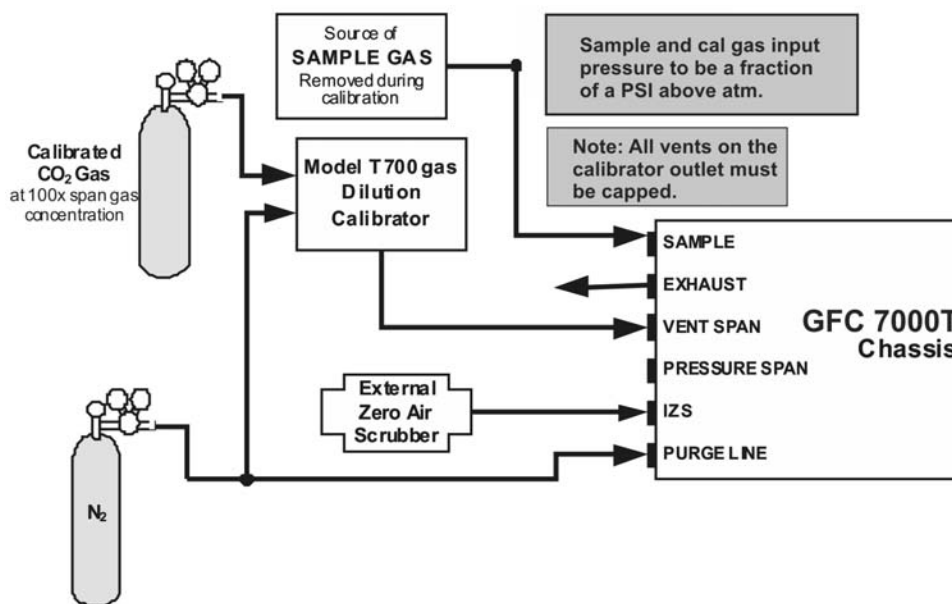
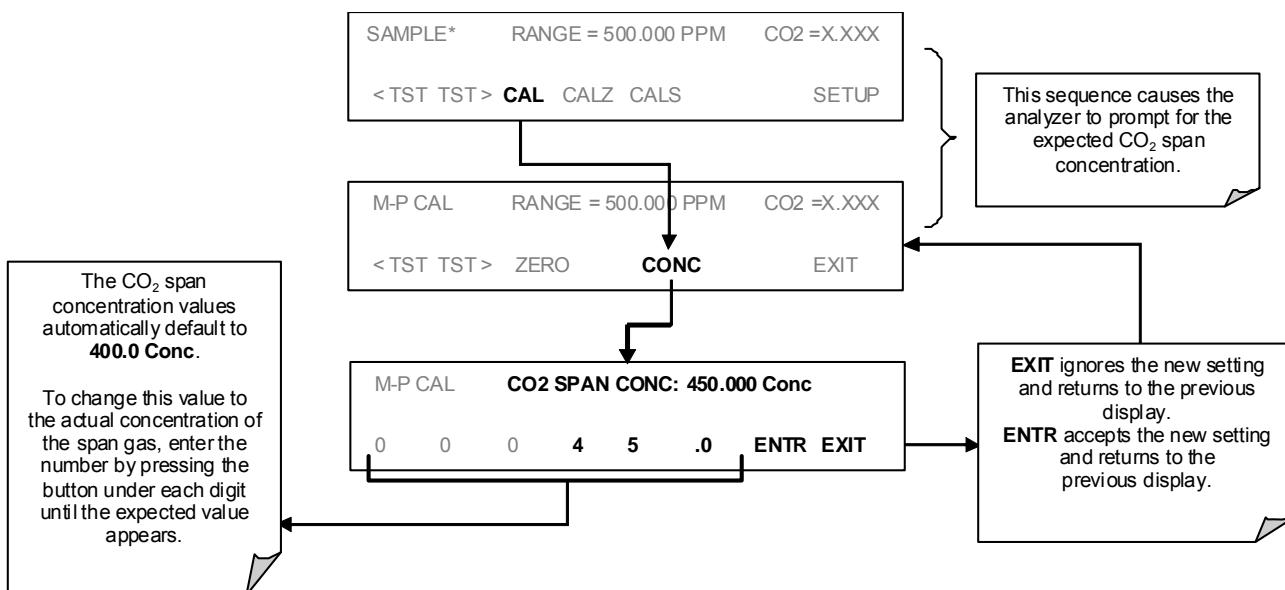

Figure 7-4: Pneumatic Connections – Ambient Zero/Pressurized Span Valves and External Zero Air Scrubber

STEP TWO: Set the expected CO₂ Span Gas concentration:



NOTE

For this Initial Calibration it is important to independently verify the PRECISE CO₂ Concentration Value of the SPAN gas.

If the source of the Span Gas is from a Calibrated Bottle, use the exact concentration value printed on the bottle.

STEP THREE: Perform the zero/span calibration. Zero and span checks using the zero/span valve option are similar to that described in Section 7.2, except that zero air and span gas is supplied to the analyzer through the zero/span valves rather than through the sample inlet port.

The zero and cal operations are initiated directly and independently with dedicated buttons (**CALZ & CALS**).

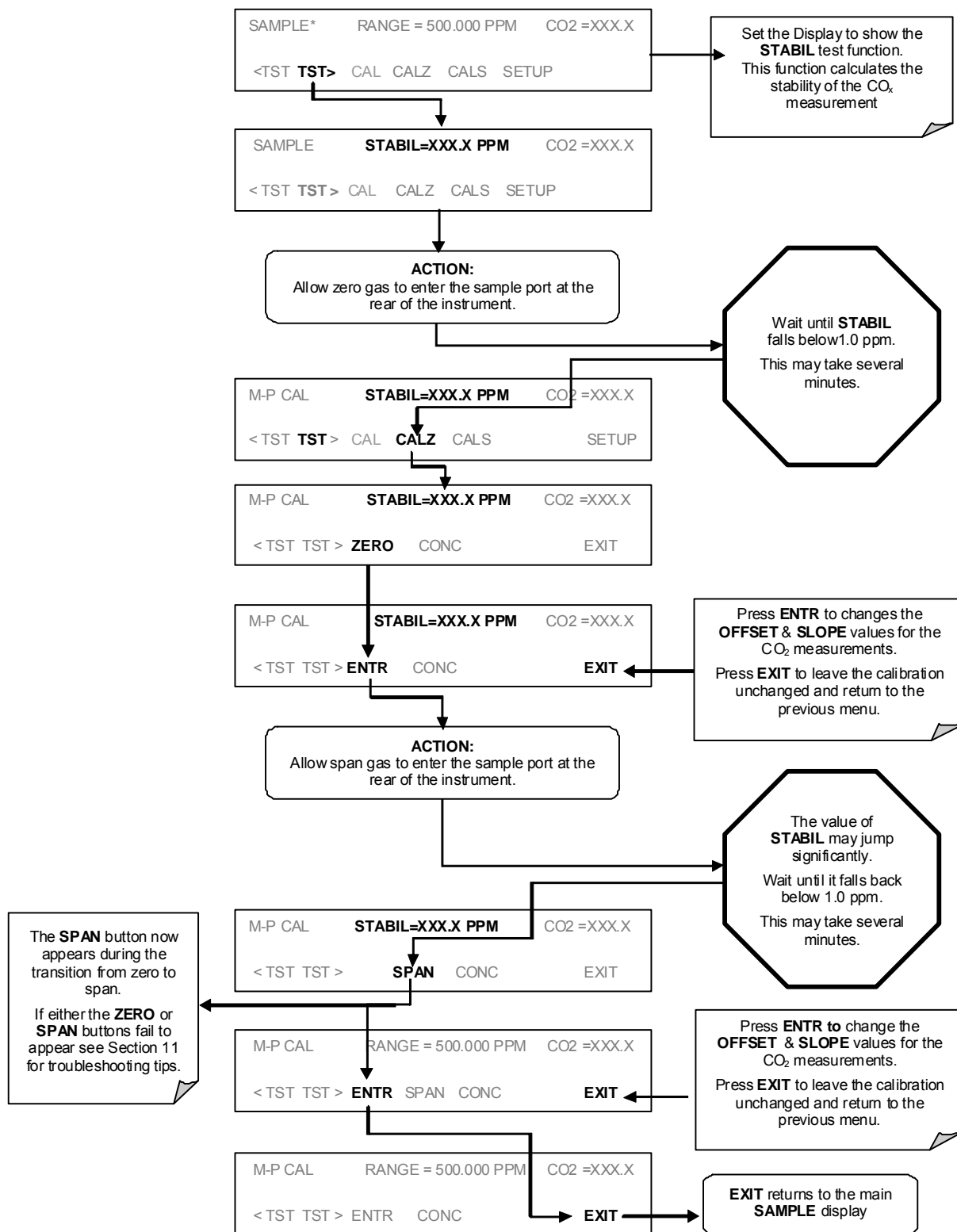

7.5. Manual Calibration Checks with Zero/Span Valves

Zero and span checks using the VARIOUS zero/span valve options available for the GFC 7000T are similar to that described in Section 7.3, except that the zero and calibration operations are initiated directly and independently with dedicated buttons CALZ and CALS.

To perform a manual calibration check of an analyzer with a valve option installed, use the following method.

STEP ONE: Connect the sources of Zero Air and Span Gas as shown in Figures 7-3 or 7-4.

STEP TWO: Perform the zero/span check.

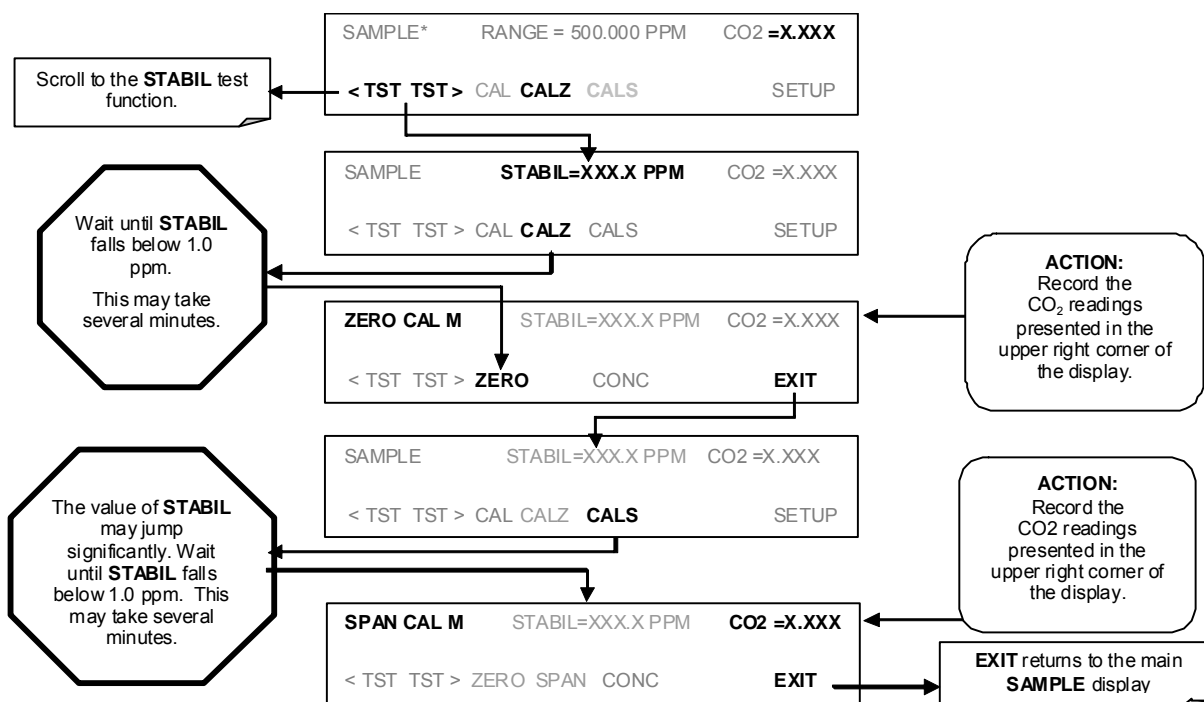

7.5.1. Zero/Span Calibration on Auto Range or Dual Ranges

If the analyzer is being operated in dual range mode or auto range mode, then the high and low ranges must be independently calibrated.

When the analyzer is in either dual or auto range modes the user must run a separate calibration procedure for each range. After pressing the **CAL**, **CALZ** or **CALS** buttons the user is prompted for the range that is to be calibrated as seen in the **CALZ** example below:

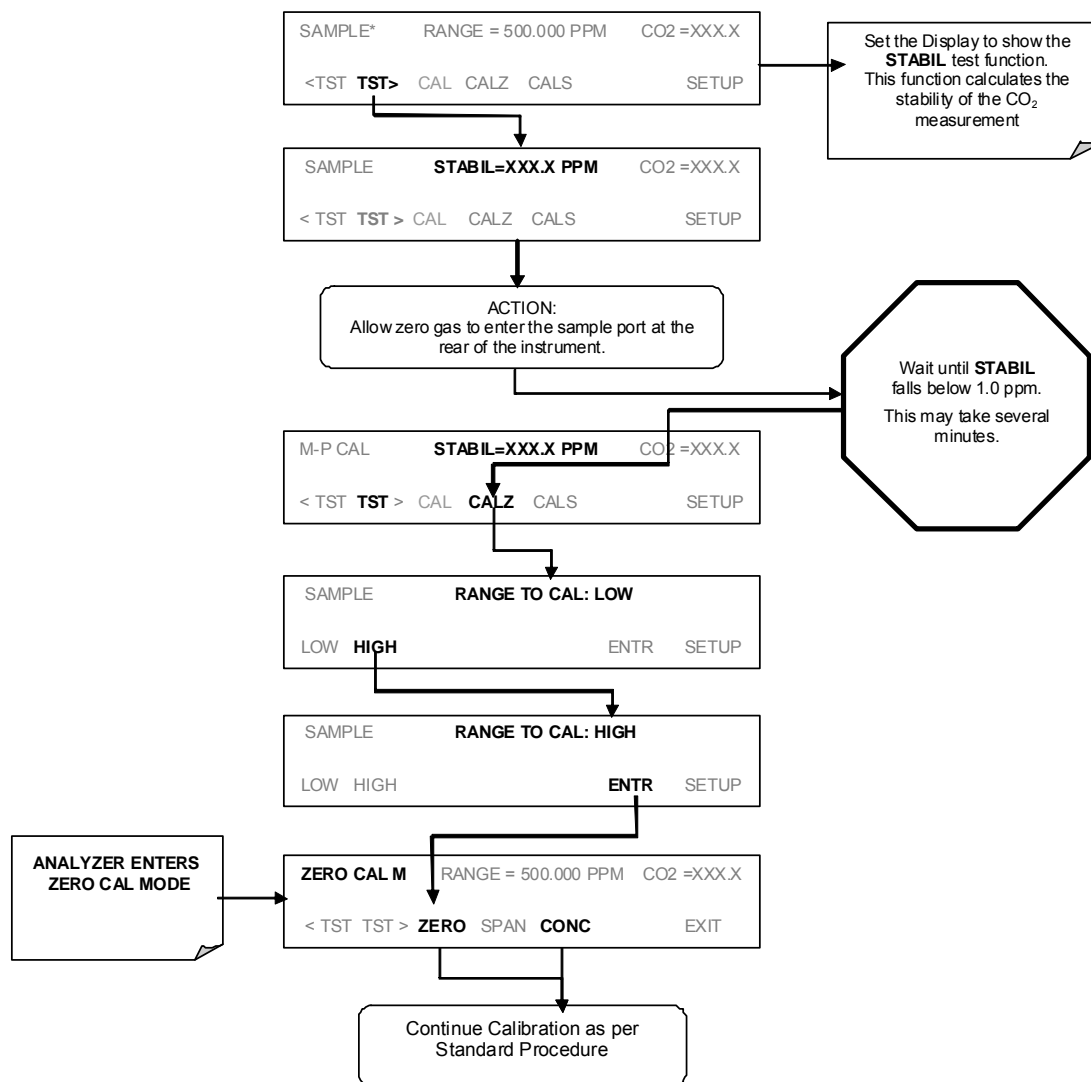

Once this selection is made, the calibration procedure continues as previously described in Section 7.2. The other range may be calibrated by starting over from the main **SAMPLE** display.

7.5.2. Use of Zero/Span Valves with Remote Contact Closure

Contact closures for controlling calibration are located on the rear panel CONTROL IN connector. Instructions for setup and use of these contacts are found in Section 6.15.1.2. When the contacts are closed for at least 5 seconds, the instrument switches into zero or span mode. The remote calibration contact closures may be activated in any order. It is recommended that contact closures remain closed for at least 10 minutes to establish a reliable reading.

The instrument will stay in the selected mode for as long as the contacts remain closed. If calibration is enabled, the GFC 7000T will re-calibrate when the contact is opened, then go into SAMPLE mode. If calibration is disabled, the instrument will return to SAMPLE mode, leaving the calibration unchanged.

7.6. Automatic Zero/Span Cal/Check (AutoCal)

The AutoCal system allows unattended periodic operation of the ZERO/SPAN valve options by using the GFC 7000T's internal time of day clock. AutoCal operates by executing SEQUENCES programmed by the user to initiate the various calibration modes of the analyzer and open and close valves appropriately. It is possible to program and run up to 3 separate sequences (**SEQ1**, **SEQ2** and **SEQ3**). Each sequence can operate in one of 3 Modes, or be disabled.

Table 7-1: AUTOCAL Modes

MODE NAME	ACTION
DISABLED	Disables the Sequence
ZERO	Causes the Sequence to perform a zero calibration/check
ZERO-SPAN	Causes the Sequence to perform a zero and span concentration calibration/check
SPAN	Causes the Sequence to perform a span concentration calibration/check

For each mode there are seven parameters that control operational details of the SEQUENCE. They are:

Table 7-2: AutoCal ATTRIBUTE Setup Parameters

ATTRIBUTE NAME	ACTION
TIMER ENABLED	Turns on the Sequence timer
STARTING DATE	Sequence will operate after Starting Date
STARTING TIME	Time of day sequence will run
DELTA DAYS	Number of days to skip between each Seq. execution
DELTA TIME	Number of hours later each "Delta Days" Seq is to be run
DURATION	Number of minutes the sequence operates
CALIBRATE	Enable to do a calibration – Disable to do a cal check only

The following example sets Sequence #2 to do a Zero-Span Calibration every other day starting at 1 am on September 4, 2001, lasting 15 minutes, without calibration. This will start ½ hour later each iteration.

MODE AND ATTRIBUTE	VALUE	COMMENT
Sequence	2	Define Sequence #2
Mode	ZERO-SPAN	Select Zero and Span Mode
Timer Enable	ON	Enable the timer
Starting Date	Sept. 4, 2001	Start after Sept 4, 2001
Starting Time	01:00	First Span starts at 1:00AM
Delta Days	2	Do Sequence #2 every other day
Delta Time	00:30	Do Sequence #2 ½ hr later each day
Duration	15.0	Operate Span valve for 15 min
Calibrate	NO	Do not calibrate at end of Sequence

NOTE

The programmed STARTING_TIME must be a minimum of 5 minutes later than the real time clock (See Section 6.10 for setting real time clock).

NOTE

Avoid setting two or more sequences at the same time of the day. Any new sequence which is initiated whether from a timer, the COM ports, or the contact closure inputs will override any sequence which is in progress.

NOTE

If at any time an illegal entry is selected (Example: Delta Days > 367) the ENTR button will disappear from the display.



To program the Sequence:

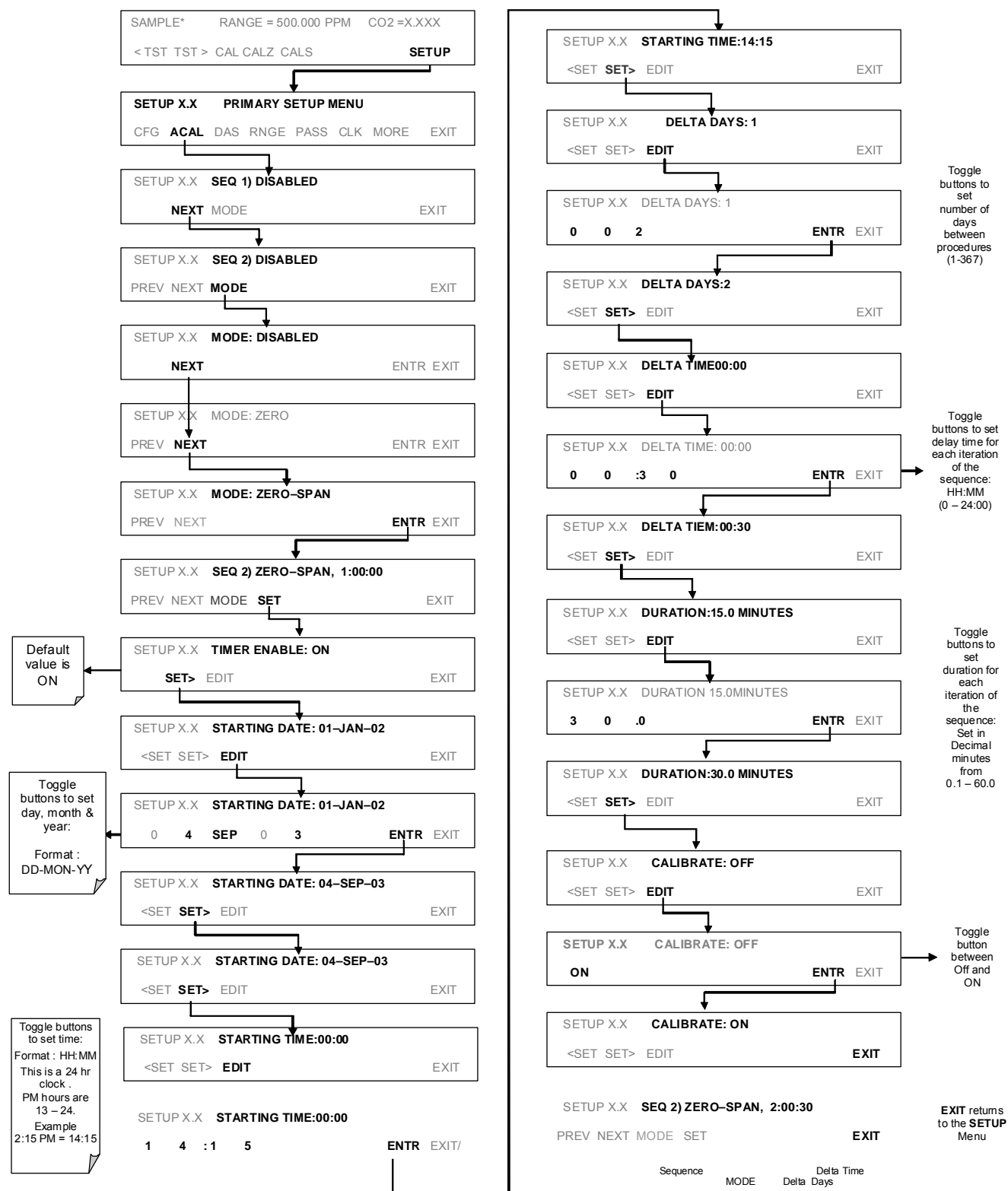

7.6.1. AutoCal with Auto or Dual Reporting Ranges Modes Selected

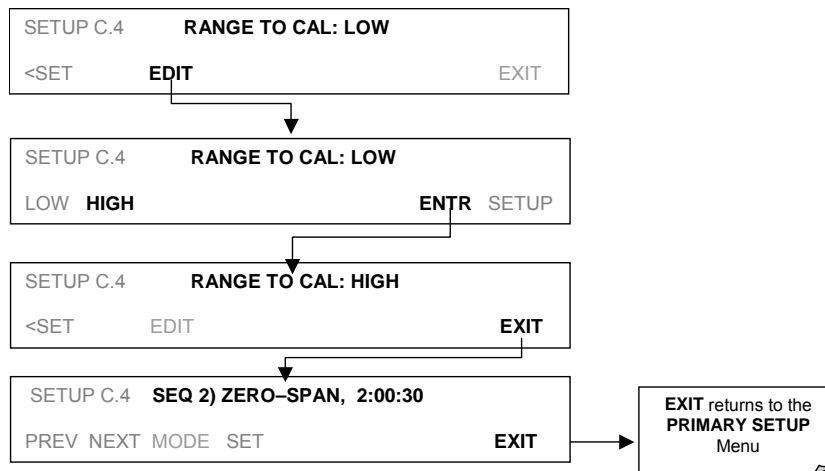

NOTE

In order to automatically calibrate both the HIGH and LOW ranges, you must set up a separate sequence for each.

7.7. Calibration Quality

After completing one of the calibration procedures described above, it is important to evaluate the analyzer’s calibration SLOPE and OFFSET parameters. These values describe the linear response curve of the analyzer. The values for these terms, both individually and relative to each other, indicate the quality of the calibration. To perform this quality evaluation, you will need to record the values of both test functions (Section 6.2.1 or Appendix A-3), all of which are automatically stored in the DAS channel CALDAT for data analysis, documentation and archival.

Make sure that these parameters are within the limits listed in Table 7-3 and frequently compare them to those values on the *Final Test and Checkout Sheet* that came attached to your manual, which should not be significantly different. If they are, refer to the troubleshooting Section 11.

Table 7-3: Calibration Data Quality Evaluation

FUNCTION	MINIMUM VALUE	OPTIMUM VALUE	MAXIMUM VALUE
SLOPE	0.700	1.000	1.300
OFFS	-0.500	0.000	0.500

These values should not be significantly different from the values recorded on the Teledyne Instruments *Final Test and Validation Data* sheet that was shipped with your instrument. If they are, refer to the troubleshooting Section 11.

The default DAS configuration records all calibration values in channel **CALDAT** as well as all calibration check (zero and span) values in its internal memory. Up to 200 data points are stored for up 4 years of data (on weekly calibration checks) and a lifetime history of monthly calibrations. Review these data to see if the zero and span responses change over time. These channels also store the STABIL value (standard deviation of CO concentration) to evaluate if the analyzer response has properly leveled off during the calibration procedure. Finally, the CALDAT channel also stores the converter efficiency for review and documentation.

If your instrument has an O₂ sensor option installed that should be calibrated as well.

8. MAINTENANCE SCHEDULE & PROCEDURES

Predictive diagnostic functions, including data acquisition records, failure warnings and test functions built into the analyzer, allow the user to determine when repairs are necessary without performing painstaking preventative maintenance procedures. There are, however, a minimal number of simple procedures that when performed regularly will ensure that the analyzer continues to operate accurately and reliably over its lifetime. Repairs and troubleshooting are covered in Section 11 of this manual.

8.1. Maintenance Schedule

Table 9-1 shows a typical maintenance schedule for the analyzer. Please note that in certain environments (i.e. dusty, very high ambient pollutant levels) some maintenance procedures may need to be performed more often than shown.

NOTE

A Span and Zero Calibration Check (see CAL CHECK REQ'D Column of Table 9-1) must be performed following certain of the maintenance procedure listed below.

See Sections 7.3, 7.5 and 7.6 for instructions on performing checks.



CAUTION

Risk of electrical shock. Disconnect power before performing any of the following operations that require entry into the interior of the analyzer.



NOTE

The operations outlined in this section are to be performed by qualified maintenance personnel only.

Table 8-1: GFC 7000T Maintenance Schedule

ITEM	ACTION	FREQ	CAL CHECK REQ'D.	MANUAL	DATE PERFORMED										
Particulate Filter	Replace	Weekly or as needed	Yes												
Verify Test Functions	Record and analyze	Weekly or after any Maintenance or Repair	No												
Perform Flow Check	Check Flow	Annually	No												
Perform Leak Check	Verify Leak Tight	Annually or after any Maintenance or Repair	No												
Pneumatic lines	Examine and clean	As needed	Yes if cleaned												
Cleaning	Clean	As needed	Only if cover remv'd												

Table 8-2: GFC 7000T Test Function Record

FUNCTION	OPERATING MODE*	DATE RECORDED											
STABILITY	ZERO CAL												
CO2 MEAS	ZERO CAL												
MR RATIO	Zero CAL												
	SPAN CAL												
PRES	SAMPLE												
PHT DRIVE	SAMPLE After Warm-up												
SLOPE	SPAN CAL												
OFFSET	ZERO CAL												

8.2. Predicting Failures Using the Test Functions

The Test Functions can be used to predict failures by looking at how their values change over time. Initially it may be useful to compare the state of these Test Functions to the values recorded on the printed record of the final calibration performed on your instrument at the factory, p/n 04307. Table 9-3 can be used as a basis for taking action as these values change with time. The internal data acquisition system (DAS) is a convenient way to record and track these changes. Use APICOM to download and review this data from a remote location.

Table 8-3: Predictive uses for Test Functions

FUNCTION	CONDITION	BEHAVIOR	INTERPRETATION
STABILITY	Zero Cal	Increasing	Pneumatic Leaks – instrument & sample system Detector deteriorating
CO2 MEAS	Zero Cal	Decreasing	Source Aging Detector deteriorating Optics getting dirty or contaminated
MR RATIO	Zero Cal	Increasing	Source Aging Detector deteriorating Contaminated zero gas (H ₂ O)
		Decreasing	Source Aging Detector deteriorating GFC Wheel Leaking Pneumatic Leaks Contaminated zero gas (CO ₂)
	Span Cal	Increasing	Source Aging Pneumatic Leaks – instrument & sample system Calibration system deteriorating
		Decreasing	Source Aging GFC Wheel Leaking Calibration system deteriorating
PRES	Sample	Increasing > 1"	Pneumatic Leak between sample inlet and Sample Cell Change in sampling manifold
		Decreasing > 1"	Dirty particulate filter Pneumatic obstruction between sample inlet and Sample Cell Obstruction in sampling manifold
PHT DRIVE	Any, but with Bench Temp at 48°C	Increasing	Mechanical Connection between IR-Detector and Sample Cell deteriorating IR-Photodetector deteriorating
OFFSET	Zero Cal	Increasing	See MR Ratio - Zero Cal Decreasing above
		Decreasing	See MR Ratio - Zero Cal Increasing above
SLOPE	Span Cal	Increasing	See MR Ratio - Span Cal Decreasing above
		Decreasing	See MR Ratio – Span Cal Increasing above

8.3. Maintenance Procedures

The following procedures are to be performed periodically as part of the standard maintenance of the Model GFC 7000T.

8.3.1. Replacing the Sample Particulate Filter

The particulate filter should be inspected often for signs of plugging or contamination. We recommend that when you change the filter, handle it and the wetted surfaces of the filter housing as little as possible. Do not touch any part of the housing, filter element, PTFE retaining ring, glass cover and the o-ring.

To change the filter:

1. Turn OFF the analyzer to prevent drawing debris into the instrument.
2. Open the GFC 7000T's hinged front panel and unscrew the knurled retaining ring on the filter assembly.

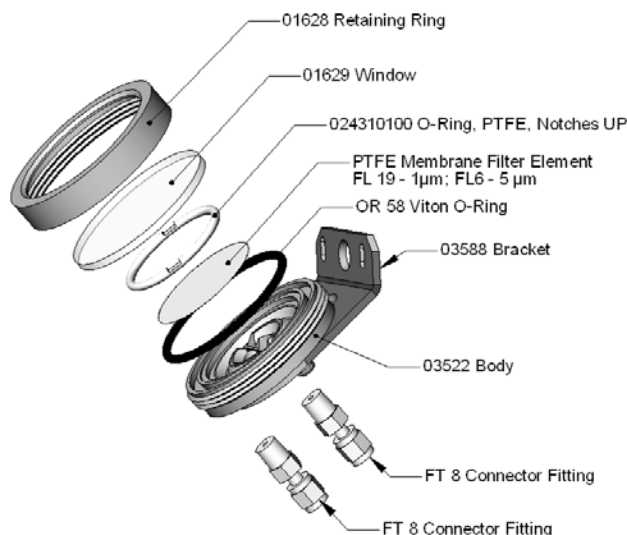

Figure 8-1: Sample Particulate Filter Assembly

3. Carefully remove the retaining ring, PTFE o-ring, glass filter cover and filter element.
4. Replace the filter, being careful that the element is fully seated and centered in the bottom of the holder.
5. Re-install the PTFE o-ring with the notches up, install the glass cover, then screw on the retaining ring and hand tighten. Inspect the seal between the edge of filter and the o-ring to assure a proper seal.
6. Re-start the Analyzer.

8.3.2. Performing Leak Checks

Leaks are the most common cause of analyzer malfunction; Section 8.3.2.1 presents a simple leak check procedure. Section 8.3.2.2 details a more thorough procedure.

8.3.2.1. Vacuum Leak Check and Pump Check

This method is easy and fast. It detects, but does not locate most leaks; it also verifies that the sample pump is in good condition.

1. Turn the analyzer ON, and allow enough time for flows to stabilize.
2. Cap the sample inlet port.
3. After several minutes, when the pressures have stabilized, note the following. In the **TEST** menu, note the **SAMPLE PRESSURE** reading.
4. If the reading is < 10 in-Hg, the pump is in good condition and there are no large leaks.
5. Check the sample gas flow. If the flow is <10 cm³/min and stable, there are no large leaks in the instrument's pneumatics.

8.3.2.2. Pressure Leak Check

If you can't locate the leak by the above procedure, use the following procedure. Obtain a leak checker similar to the Teledyne Instruments part number 01960, which contains a small pump, shut-off valve, and pressure gauge. Alternatively, a convenient source of low-pressure gas is a tank of span gas, with the two-stage regulator adjusted to less than 15 psi with a shutoff valve and pressure gauge.

	<p style="text-align: center;">CAUTION</p> <p style="text-align: center;">Do not use bubble solution with vacuum applied to the analyzer. The solution may contaminate the instrument. Do not exceed 15 PSIG pressure.</p>
---	--

1. Turn OFF power to the instrument.
2. Install a leak checker or tank of gas as described above on the sample inlet at the rear panel.
3. Remove the instrument cover and locate the inlet side of the sample pump. Remove the flow assembly from the pump and plug it with the appropriate gas-tight fitting.
4. Pressurize the instrument with the leak checker, allowing enough time to fully pressurize the instrument through the critical flow orifice. Check each fitting with soap bubble solution, looking for bubbles. Once the fittings have been wetted with soap solution, do not re-apply vacuum, as it will suck soap solution into the instrument and contaminate it. Do not exceed 15 psi pressure.
5. If the instrument has one of the zero and span valve options, the normally closed ports on each valve should also be separately checked. Connect the leak checker to the normally closed ports and check with soap bubble solution.
6. Once the leak has been located and repaired, the leak-down rate should be < 1 in-Hg (0.4 psi) in 5 minutes after the pressure is shut off.

8.3.3. Performing a Sample Flow Check

	<p>CAUTION</p> <p>Always use a separate calibrated flow meter capable of measuring flows in the 0 – 1000 cc/min range to measure the gas flow rate through the analyzer.</p> <p>DO NOT use the built in flow measurement viewable from the Front Panel of the instrument. This measurement is only for detecting major flow interruptions such as clogged or plugged gas lines.</p>
---	--

See Figure 3-4 for SAMPLE port location.

1. Attach the Flow Meter to the sample inlet port on the rear panel. Ensure that the inlet to the Flow Meter is at atmospheric f.
2. Sample flow should be 800 cc/min \pm 10%.
3. Once an accurate measurement has been recorded by the method described above, adjust the analyzer's internal flow sensors (See Section 6.13.8)

Low flows indicate blockage somewhere in the pneumatic pathway, typically a plugged sintered filter or critical flow orifice in one of the analyzer's flow control assemblies. High flows indicate leaks downstream of the Flow Control Assembly.

8.3.4. Cleaning the Optical Bench

The GFC 7000T sensor assembly and optical bench is complex and delicate. Disassembly and cleaning is not recommended. Please check with the factory before disassembling the optical bench.

8.3.5. Cleaning Exterior Surfaces of the GFC 7000T

If necessary, the exterior surfaces of the GFC 7000T can be cleaned with a clean damp cloth. Do not submerge any part of the instrument in water or cleaning solution.

9. THEORY OF OPERATION

The Model GFC 7000T Gas Filter Correlation Carbon Dioxide Analyzer is a microprocessor-controlled analyzer that determines the concentration of carbon dioxide (CO₂) in a sample gas drawn through the instrument. It requires that sample and calibration gasses be supplied at ambient atmospheric pressure in order to establish a stable gas flow through the sample chamber where the gases ability to absorb infrared radiation is measured.

Calibration of the instrument is performed in software and does not require physical adjustments to the instrument. During calibration the microprocessor measures the current state of the IR Sensor output and various other physical parameters of the instrument and stores them in memory.

The microprocessor uses these calibration values, the IR absorption measurements made on the sample gas along with data regarding the current temperature and pressure of the gas to calculate a final CO₂ concentration.

This concentration value and the original information from which it was calculated are stored in one of the unit's internal data acquisition system (DAS - See Sections 6.7) as well as reported to the user via a vacuum florescent display or a variety of digital and analog signal outputs.

9.1. Measurement Method

9.1.1. Beer's Law

The basic principle by which the analyzer works is called Beer's Law. It defines the how light of a specific wavelength is absorbed by a particular gas molecule over a certain distance. The mathematical relationship between these three parameters is:

$$I = I_0 e^{-\alpha Lc}$$

Where:

I₀ is the intensity of the light if there was no absorption.

I is the intensity with absorption.

L is the absorption path, or the distance the light travels as it is being absorbed.

C is the concentration of the absorbing gas. In the case of the Model GFC 7000T, carbon dioxide (CO₂).

α is the absorption coefficient that tells how well CO₂ absorbs light at the specific wavelength of interest.

9.1.2. Measurement Fundamentals

In the most basic terms, the Model GFC 7000T uses a high energy heated element to generate a beam of broad-band IR light with a known intensity (measured during Instrument calibration. This beam is

directed through multi-pass cell filled with sample gas. The sample cell uses mirrors at each end to reflect the IR beam back and forth through the sample gas to generate a 2.5 meter absorption path (see Figure 10-1). This length was chosen to give the analyzer maximum sensitivity to fluctuations in CO₂ density.

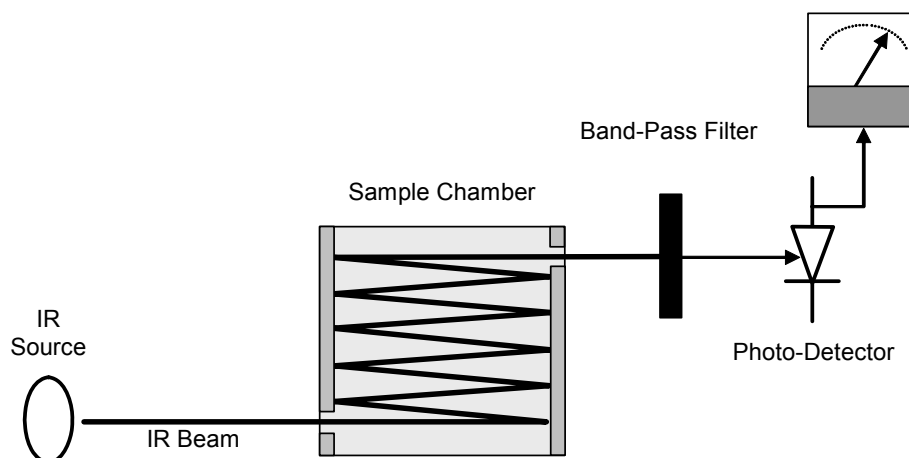

Figure 9-1: Measurement Fundamentals

Upon exiting the sample cell, the beam shines through a band-pass filter that allows only light at a wavelength of 4.3 μm to pass. Finally, the beam strikes a solid-state photo-detector that converts the light signal into a modulated voltage signal representing the attenuated intensity of the beam.

9.1.3. Gas Filter Correlation

Unfortunately, water vapor absorbs light at 4.3 μm too. To overcome the interfering effects of water vapor the Model GFC 700T adds another component to the IR light path called a gas filter correlation (GFC) wheel (see Figure 10-2).

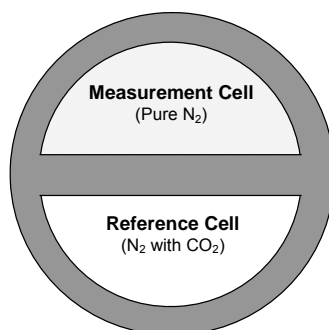

Figure 9-2: GFC Wheel

9.1.3.1. The GFC Wheel

A GFC wheel is a metallic wheel into which two chambers are carved. The chambers are sealed on both sides with material transparent to 4.3 μm IR radiation creating two airtight cavities. Each cavity is filled with specially composed gases. One cell is filled with pure N₂ (the measure cell). The other is filled with a combination of N₂ and a high concentration of CO₂ (the reference cell).

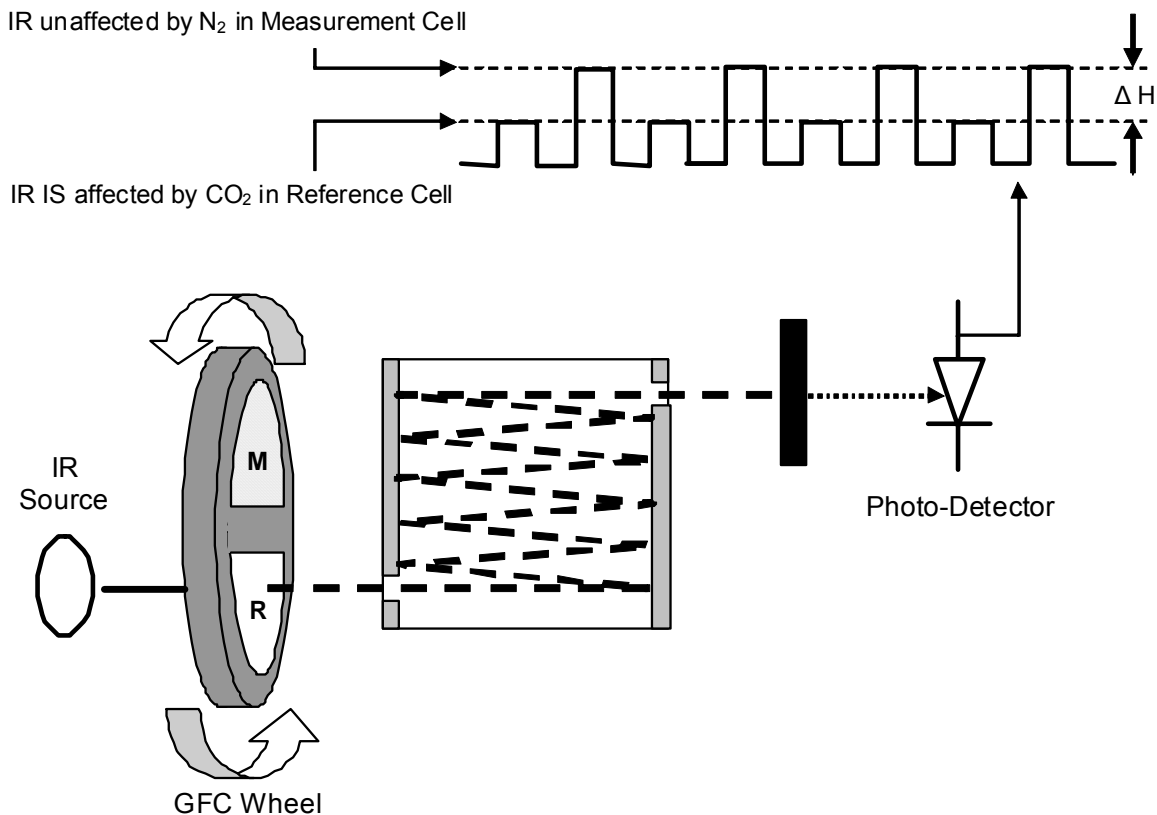

Figure 9-3: Measurement Fundamentals with GFC Wheel

As the GFC wheel spins, the IR light alternately passes through the two cavities. When the beam is exposed to the reference cell, the CO₂ in the gas filter wheel strips the beam of most of the IR at 4.3 μ m. When the light beam is exposed to the measurement cell, the N₂ in the filter wheel does not absorb IR light. This results in a fluctuation in the intensity of the IR light striking the photo-detector (See Figure 10-3) that results in the output of the detector resembling a square wave.

9.1.3.2. The Measure Reference Ratio

The Model GFC 7000T determines the amount of CO₂ in the sample chamber by computing the ratio between the peak of the measurement pulse (**CO₂ MEAS**) and the peak of the reference pulse (**CO₂ REF**).

If no gases exist in the sample chamber that absorb light at 4.3 μ m, the high concentration of CO₂ in the gas mixture of the reference cell will attenuate the intensity of the IR beam by 60% giving a M/R ratio of approximately 2.4:1.

Adding CO₂ to the sample chamber causes the peaks corresponding to both cells to be attenuated by a further percentage. Since the intensity of the light passing through the measurement cell is greater, the effect of this additional attenuation is greater. This causes **CO₂ MEAS** to be more sensitive to the presence of CO₂ in the sample chamber than **CO₂ REF** and the ratio between them (M/R) to move closer to 1:1 as the concentration of CO₂ in the sample chamber increases.

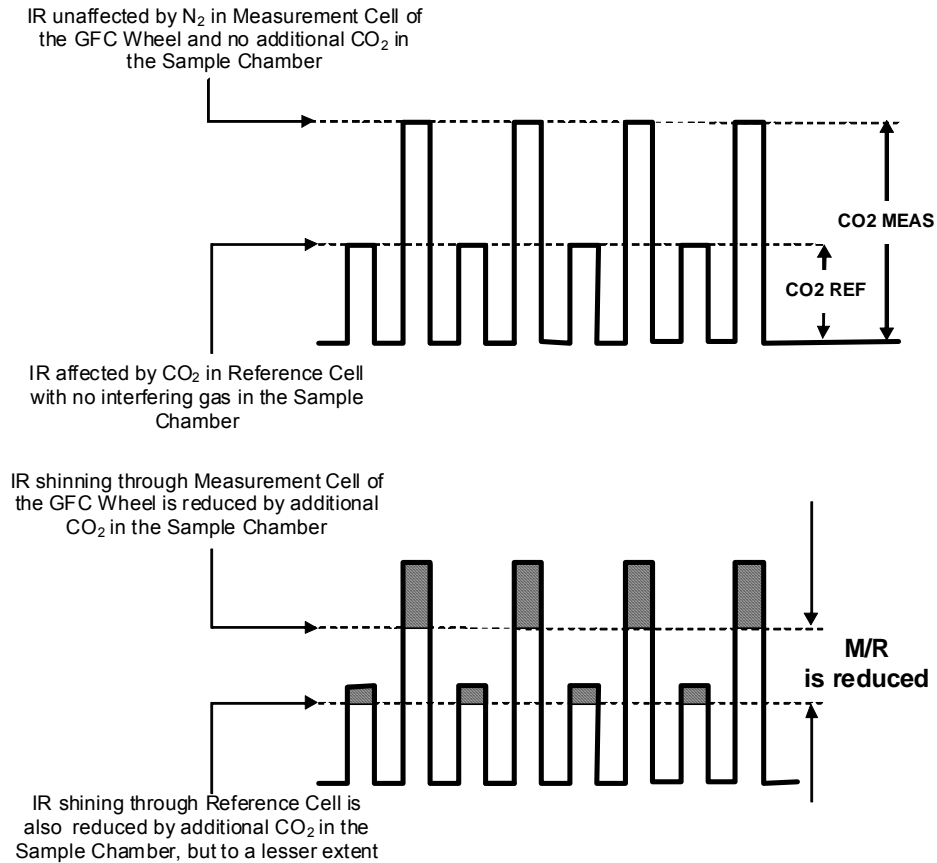

Figure 9-4: Affect of CO₂ in the Sample on CO₂ MEAS & CO₂ REF

Once the Model GFC 7000T has computed this ratio, a look-up table is used, with interpolation, to linearize the response of the instrument. This linearized concentration value is combined with calibration **SLOPE** and **OFFSET** values to produce the CO₂ concentration which is then normalized for changes in sample pressure.

9.1.4. Interference and Signal to Noise Rejection

If an interfering gas, such as H₂O vapor is introduced into the sample chamber, the spectrum of the IR beam is changed in a way that is identical for both the reference and the measurement cells, but without changing the ratio between the peak heights of **CO₂ MEAS** and **CO₂ REF**. In effect, the difference between the peak heights remains the same.

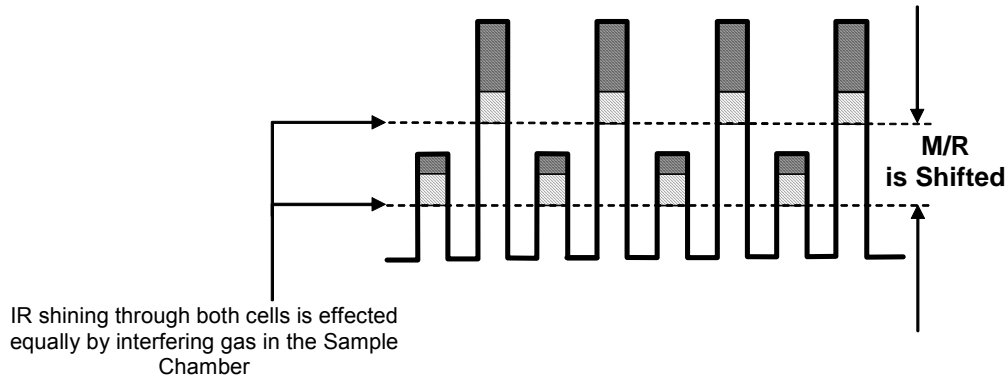

Figure 9-5: Effects of Interfering Gas on CO₂ MEAS & CO₂ REF

Thus, the difference in the peak heights and the resulting M/R ratio is only due to CO₂ and not to interfering gases. In this way, Gas filter correlation rejects the effects of interfering gases and so that the analyzer responds only to the presence of CO₂.

To improve the signal-to-noise performance of the IR photo-detector, the GFC wheel also incorporates an optical mask that chops the IR beam into alternating pulses of light and dark at six times the frequency of the measure/reference signal. This limits the detection bandwidth helping to reject interfering signals from outside this bandwidth improving the signal to noise ratio.

The IR Signal as the Photo-Detector sees it after being chopped by the GFC Wheel Screen

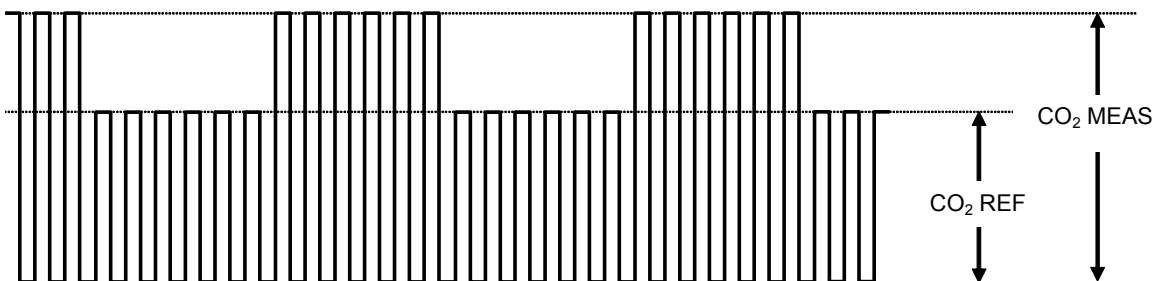

Figure 9-6: Chopped IR Signal

9.1.4.1. Ambient CO₂ Interference Rejection

CO₂ absorbs IR light very well. So well that even the narrow volume of ambient air between the IR source and the sample chamber is enough to alter the analyzer's measured concentration of CO₂. Also, ambient air, which averages around 350 ppm to 400 ppm, will vary significantly over the course of the day. The ambient CO₂ concentration can rise as high as 1 000 ppm during the time of the day when people are present. It can fluctuate \pm 300 ppm as the photosynthesis of plant life in the nearby area increases during the day and decreases at night.

The basic design of the GFC 7000T rejects most of this interference at a 100:1 ratio; however this still can allow small fluctuations in CO₂ concentration during the course of the day. To completely remove all effects of ambient CO₂ from the analyzer's measurement of CO₂, dried air, scrubbed of all CO₂ is pumped into the GFC wheel housing to purge all ambient CO₂ (see Figure 10-7)



9.2. Pneumatic Operation

	<p>CAUTION</p> <p>It is important that the sample airflow system is both leak tight and not pressurized over ambient pressure.</p> <p>Regular leak checks should be performed on the analyzer as described in the maintenance schedule, Table 9-1.</p> <p>Procedures for correctly performing leak checks can be found in Section 9.3.3.</p>
---	---

The sample gas is to be made available to the analyzer at a pressure slightly above ambient but sufficient to allow for a proper flow through the sample lines. The internal sample system has been designed with minimal restriction allowing sufficient flow at very low pressure. The input pressure must be reduced and regulated from the process pressure using a pressure regulator, needle valve, restrictor, critical orifice or any combination thereof before entering the analyzer.

9.2.1. Sample Gas Flow

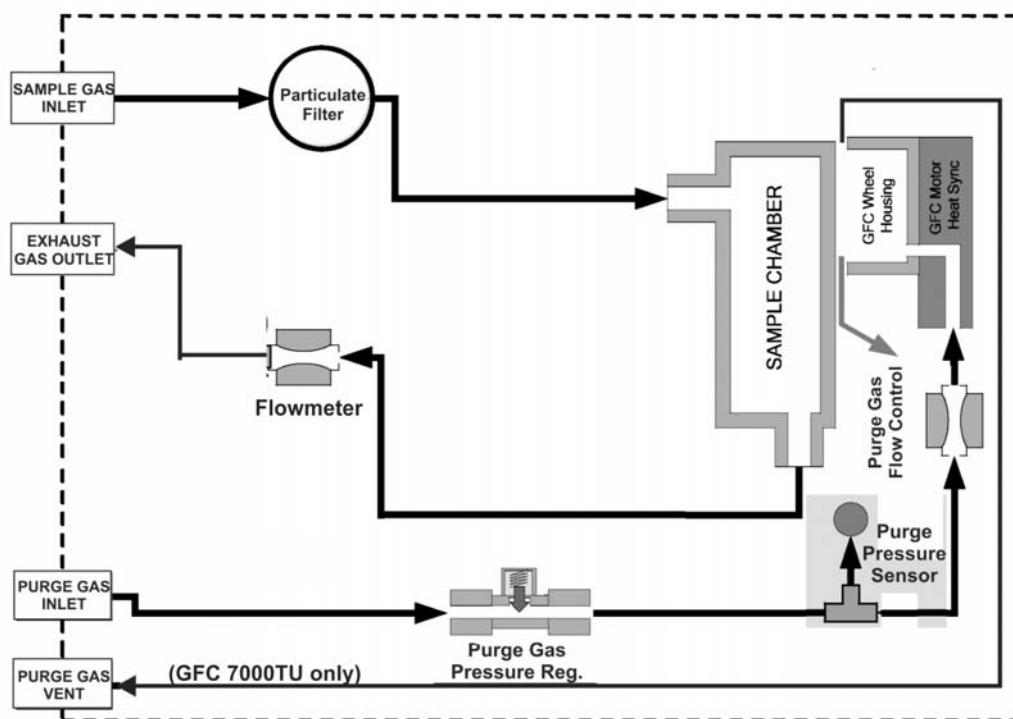

Figure 9-7: Internal Pneumatic Flow – Basic Configuration

9.2.2. Flow Rate Control

To maintain a constant flow rate of the sample gas through the Model GFC 7000T, the user must install some means of flow control be it a needle valve, critical orifice, etc. sufficient to provide a flow rate of 800 cm³/min. The standard instrument, as built, does not possess any inherent means of flow control.

9.2.3. Critical Flow Orifice

Although not installed in the GFC 7000T as a standard item, critical flow orifices are a remarkably simple way to regulate stable gas flow rates. They operate without moving parts by taking advantage of the laws of fluid dynamics. By restricting the flow of gas through the orifice, a pressure differential is created.

As the pressure on the downstream side of the orifice continues to drop, the speed that the gas flows through the orifice continues to rise. Once the ratio of upstream pressure to downstream pressure is greater than 2:1, the velocity of the gas through the orifice reaches the speed of sound. As long as that ratio stays at least 2:1 the gas flow rate is unaffected by any fluctuations, surges, or changes in downstream pressure because such variations only travel at the speed of sound themselves and are therefore cancelled out by the sonic shockwave at the downstream exit of the critical flow orifice.

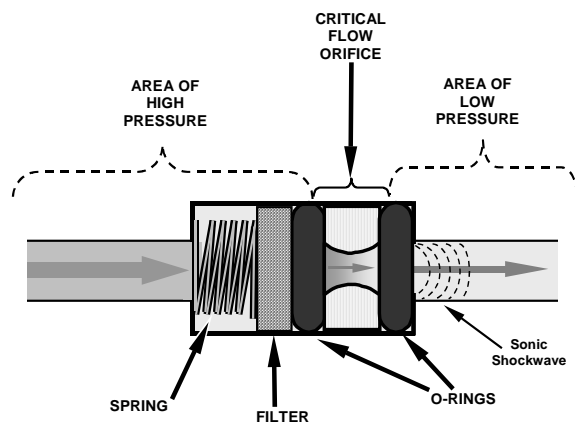

Figure 9-8: Flow Control Assembly & Critical Flow Orifice

The actual flow rate of gas through the orifice (volume of gas per unit of time), depends on the size and shape of the aperture in the orifice. The larger the hole, the more gas molecules, moving at the speed of sound, pass through the orifice. Because the flow rate of gas through the orifice is only related to the minimum 2:1 pressure differential and not absolute pressure the flow rate of the gas is also unaffected by ambient pressure fluctuations downstream.

If used, a critical flow orifice for the Model GFC 7000T should be designed to provide a flow rate of 800 cm^3/min .

9.2.4. Purge Gas Pressure Control

In order to ensure that all of the ambient CO₂ is purged from the GFC Wheel housing an adequate supply of dried air, scrubbed of CO₂ must be supplied to the **PURGE AIR** inlet at the back of the instrument.

- The minimum gas pressure of the source of purge air should be 7.5 psig.
- If the source of the purge air is shared by a Teledyne TAI's T700 (as shown in figure 3-7) the minimum gas pressure should be 25 psig and should not exceed 35 psig.

In order to maintain the proper pressure differential between the inside of the GFC wheel housing and ambient air, the GFC 7000T design includes a manually adjustable pressure regulator (see Figure 3-5 and Figure 3-6 for **Purge Gas Pressure Regulator**) that maintains the pressure of the purge air feed at 7.5 psig.

9.2.5. Particulate Filter

The Model GFC 7000T Analyzer comes equipped with a 47 mm diameter, Teflon, particulate filter with a 5 micron pore size. The filter is accessible through the front panel, which folds down to allow access, and should be changed according to the suggested maintenance schedule described in Table 9-1.

9.2.6. Pneumatic Sensors

9.2.6.1. Sample Pressure Sensor

An absolute value pressure transducer plumbed to the outlet of the sample chamber is used to measure sample pressure. The output of the sensor is used to compensate the concentration measurement for changes in air pressure. This sensor is mounted to a printed circuit board with the sample flow sensor on the sample chamber; see the following section and Figure 3-3.

9.2.6.2. Sample Flow Sensor

A thermal-mass flow sensor is used to measure the sample flow through the analyzer. The sensor is calibrated at the factory with ambient air or N₂, but can be calibrated to operate with samples consisting of other gases such as CO₂. See Section 9.3.4. This sensor is mounted to a printed circuit board with the Sample Pressure sensor on the sample chamber; see the previous section and Figure 3-3.

9.3. Electronic Operation

9.3.1. Overview

Figure 10-9 shows a block diagram of the major electronic components of the Model GFC 7000T.

The core of the analyzer is a microcomputer/central processing unit (CPU) that controls various internal processes, interprets data, makes calculations, and reports results using specialized firmware developed by Teledyne Instruments. It communicates with the user as well as receives data from and issues commands to a variety of peripheral devices via a separate printed circuit assembly called the Mother Board.

The mother board, directly mounted to the analyzer's inside rear panel, collects data, performs signal conditioning duties and routs incoming and outgoing signals between the CPU and the analyzer's other major components.

Data is generated by a gas-filter-correlation optical bench which outputs an analog signal corresponding to the concentration of CO₂ in the sample gas. This analog signal is transformed into two, pre-amplified, DC voltages (**CO2 MEAS** and **CO2 REF**) by a synchronous demodulator printed circuit assembly. **CO2 MEAS** and **CO2 REF** are converted into digital data by a unipolar, analog-to-digital converter, located on the mother board.

A variety of sensors report the physical and operational status of the analyzer's major components, again through the signal processing capabilities of the mother board. These status reports are used as data for the CO₂ concentration calculation and as trigger events for certain control commands issued by the CPU. They are stored in memory by the CPU and in most cases can be viewed but the user via the front panel display.

The CPU communicates with the user and the outside world in a variety of manners:

- Through the analyzer's touchscreen and LCD display over a clocked, digital, serial I/O bus (using a protocol called I²C)
- RS 232 & RS485 Serial I/O channels via Ethernet, Apicom or a terminal emulation program
- Various DCV and DCA analog outputs, and
- Several sets of Digital I/O channels.

Finally, the CPU issues commands via a series of relays and switches (also over the I²C bus) located on a separate printed circuit assembly to control the function of key electromechanical devices such as heaters, motors and valves.

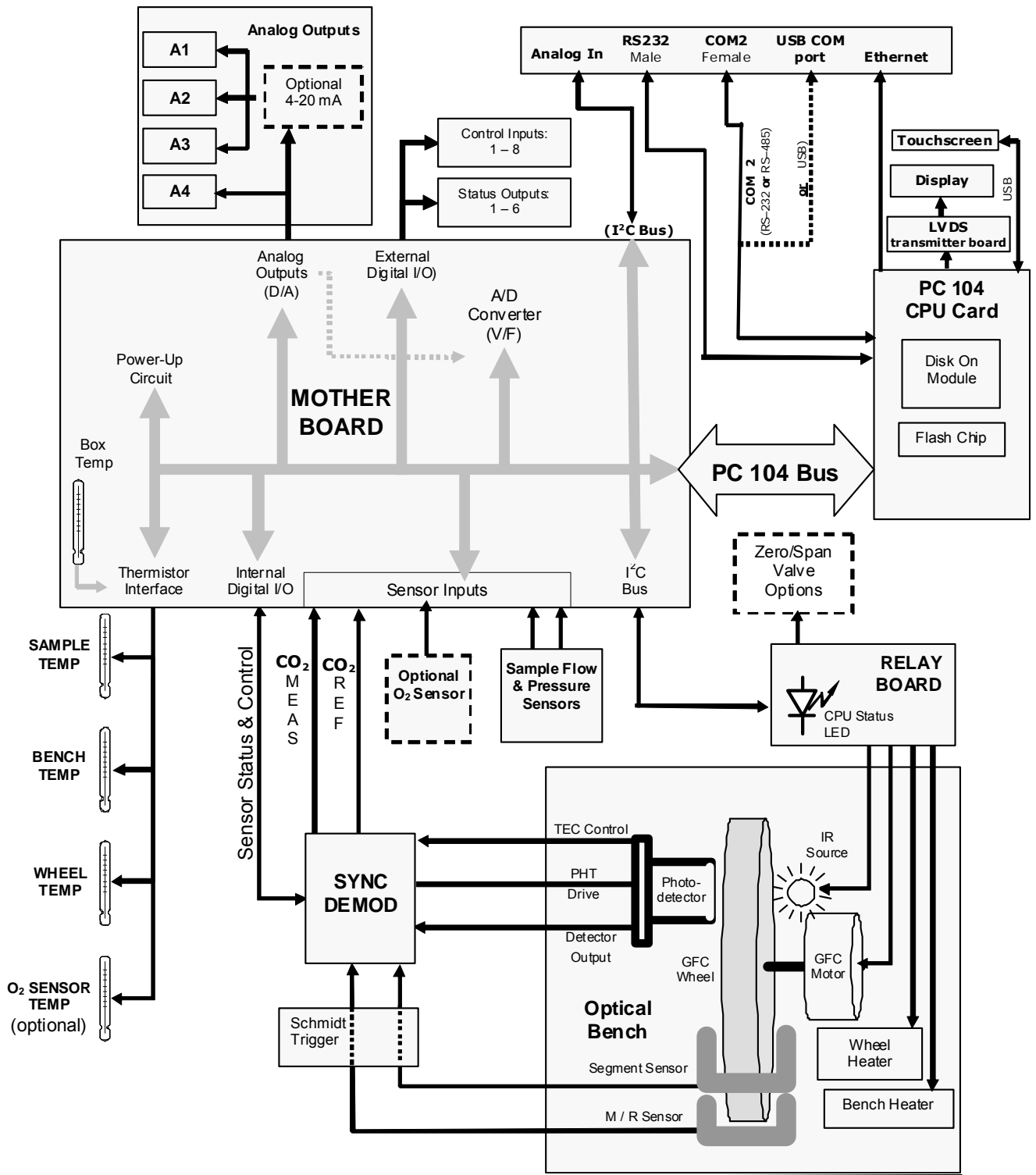

Figure 9-9: GFC 7000T Electronic Block Diagram

9.3.2. CPU

The unit's CPU card, installed on the motherboard inside the rear panel, is a low power (5 VDC, 720mA max), high performance, Vortex 86SX-based microcomputer running Windows CE. Its operation and assembly conform to the PC/104 specification.

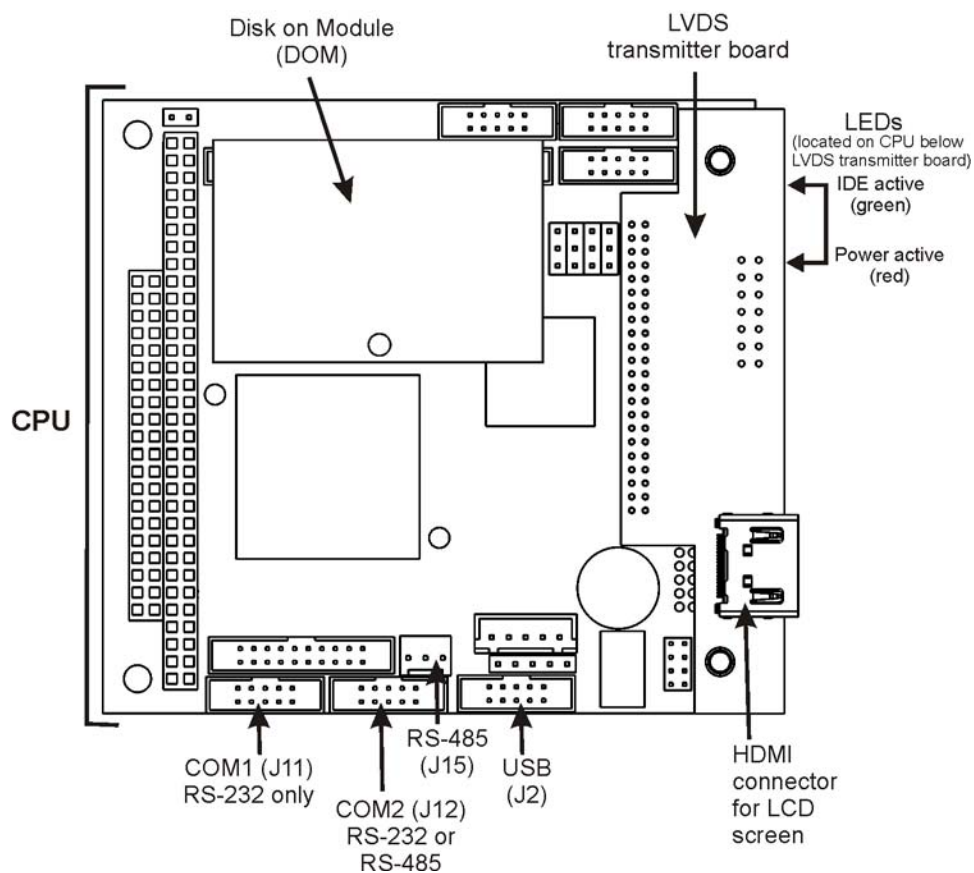

Figure 9-10: CPU Board

The CPU includes two types of non-volatile data storage: a Disk on Module (DOM) and an embedded flash chip.

9.3.2.1. Disk-On-Module (DOM)

The DOM is a 44-pin IDE flash chip with storage capacity to 129 MB. It is used to store the operating system, the Teledyne firmware, and most of the operational data generated by the analyzer's internal data acquisition system (DAS - See Section 6.7).

9.3.2.2. Flash Chip

This non-volatile, embedded flash chip includes 2MB of storage for calibration data as well as a backup of the analyzer configuration. Storing these key data on a separate, less heavily accessed chip significantly decreases the chance of data corruption. In the unlikely event that the flash chip should fail, the analyzer will continue to operate with just the DOM. However, all configuration information will be lost, requiring that the unit be recalibrated.

9.3.3. Optical Bench & GFC Wheel

Electronically, the Model GFC 7000T's optical bench, GFC wheel and associated components do more than simply measure the amount of CO₂ present in the sample chamber. A variety of other critical functions are performed here as well.

9.3.3.1. Temperature Control

Because the temperature of a gas affects its density and therefore the amount of light absorbed by that gas it is important to reduce the effect of fluctuations in ambient temperature on the Model GFC 7000T's measurement of CO₂. To accomplish this the temperature of both the sample chamber and the GFC Wheel are maintained at constant temperatures above their normal operating ranges.

Bench Temperature: To minimize the effects of ambient temperature variations on the sample measurement, the sample chamber is heated to 48°C (8 degrees above the maximum suggested ambient operating temperature for the analyzer). The heat source is a strip heater attached to the underside of the chamber housing. The temperature of the sample chamber is sensed by a thermistor attached to the sample chamber housing.

Wheel Temperature: To minimize the effects of temperature variations caused by the near proximity of the IR Source to the GFC wheel on the gases contained in the wheel, it is also raised to a high temperature level. Because the IR Source itself is very hot, the set point for this heat circuit is 68°C. The heat source is a cartridge heater implanted into the heat sync on the motor. The temperature of the wheel/motor assembly is sensed by a thermistor inserted into the heat sync.

Both heaters operate off of the AC line voltage supplied to the instrument.

9.3.3.2. IR Source

The light used to detect CO₂ in the sample chamber is generated by an element heated to approximately 1100°C producing infrared radiation across a broad band. This radiation is optically filtered after it has passed through the GFC Wheel and the sample chamber and just before it reaches the photo-detector to eliminate all black body radiation and other extraneous IR emitted by the various components of those components.

9.3.3.3. GFC Wheel

A synchronous AC motor turns the GFC wheel motor. For analyzers operating on 60Hz line power this motor turns at 1800 rpm. For those operating on 50Hz line power the spin rate is 1500 rpm. The actual spin rate is unimportant within a large rate since a phase lock loop circuit is used to generate timing pulses for signal processing.

In order to accurately interpret the fluctuations of the IR beam after it has passed through the sample gas, the GFC wheel several other timing signals are produced by other photo emitters/detectors. These devices consist of a combination LED and detector mounted so that the light emitted by the LED shines through the same mask on the GFC wheel that chops the IR beam.

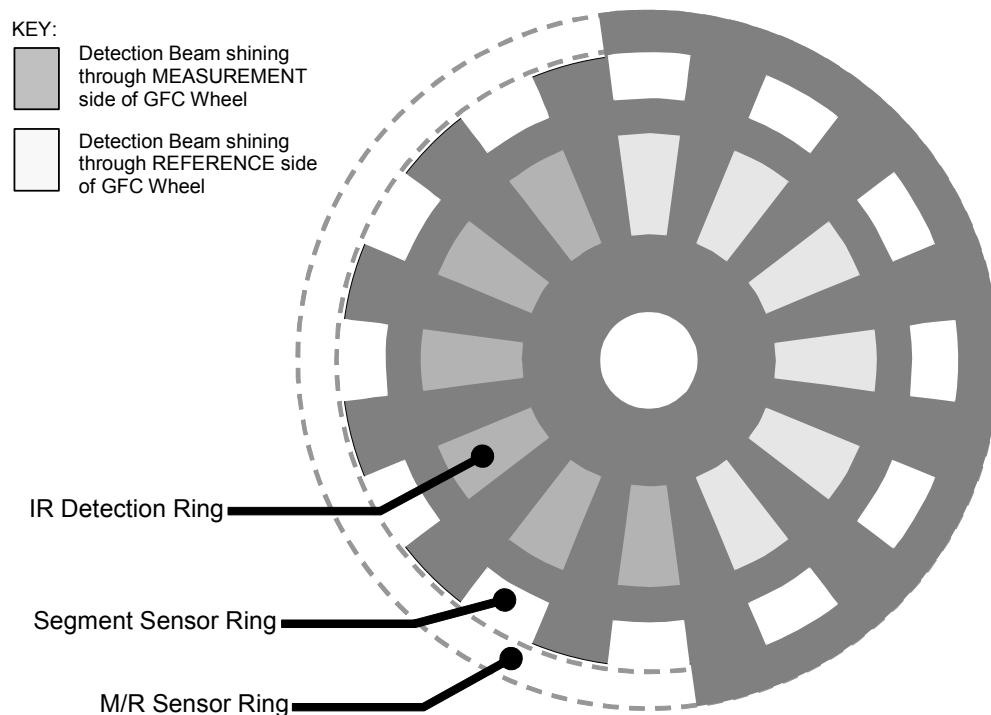

Figure 9-11: GFC Light Mask

M/R Sensor

This emitter/detector assembly that produces a signal that shines through a portion of the mask that allows light to pass for half of a full revolution of the wheel. The resulting light signal tells the analyzer whether the IR beam is shining through the measurement or the reference side of the GFC wheel.

Segment Sensor

Light from this emitter/detector pair shines through a portion of the mask that is divided into the same number of segments as the IR detector ring. It is used by the synchronous / demodulation circuitry of the analyzer to latch onto the most stable part of each measurement and reference IR pulse.

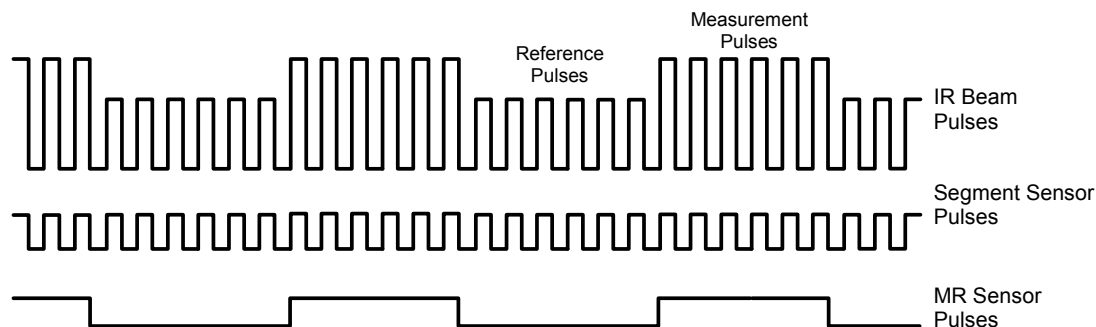

Figure 9-12: Segment Sensor and M/R Sensor Output

Schmidt Triggers

To ensure that the waveforms produced by the Segment Sensor and the M/R Sensor are properly shaped and clean, these signals are passed through a set of Schmidt Triggers circuits.

9.3.3.4. IR Photo-Detector

The IR beam is converted into an electrical signal by a cooled solid-state photo-conductive detector. The detector is composed of a narrow-band optical filter, a piece of lead-salt crystal whose electrical resistance changes with temperature, and a two-stage thermo-electric cooler.

When the analyzer is on, a constant electrical current is directed through the detector. The IR beam is focused onto the detector surface, raising its temperature and lowering its electrical resistance that results in a change in the voltage drop across the detector.

During those times that the IR beam is bright, the temperature of the detector is high; the resistance of the detector is correspondingly low and the its output voltage output is low. During those times when the IR beam intensity is low or completely blocked by the GFC Wheel mask, the temperature of the detector is lowered by the two-stage thermo-electric cooler, increasing the detectors resistance and raising the output voltage.

9.3.4. Synchronous Demodulator (Sync/Demod) Assembly

9.3.4.1. Overview

While the photo-detector converts fluctuations of the IR beam into electronic signals, the Sync / Demod Board amplifies these signals and converts them into usable information. Initially the output by the photo-detector is a complex and continuously changing waveform made up of Measure and Reference pulses. The sync/demod board demodulates this waveform and outputs two analog DC voltage signals, corresponding to the peak values of these pulses. **CO2 MEAS** and **CO2 REF** are converted into digital signals by circuitry on the motherboard then used by the CPU to calculate the CO₂ concentration of the sample gas.

Additionally the synch/demod board contains circuitry that controls the photo-detector's thermoelectric cooler as well as circuitry for performing certain diagnostic tests on the analyzer.

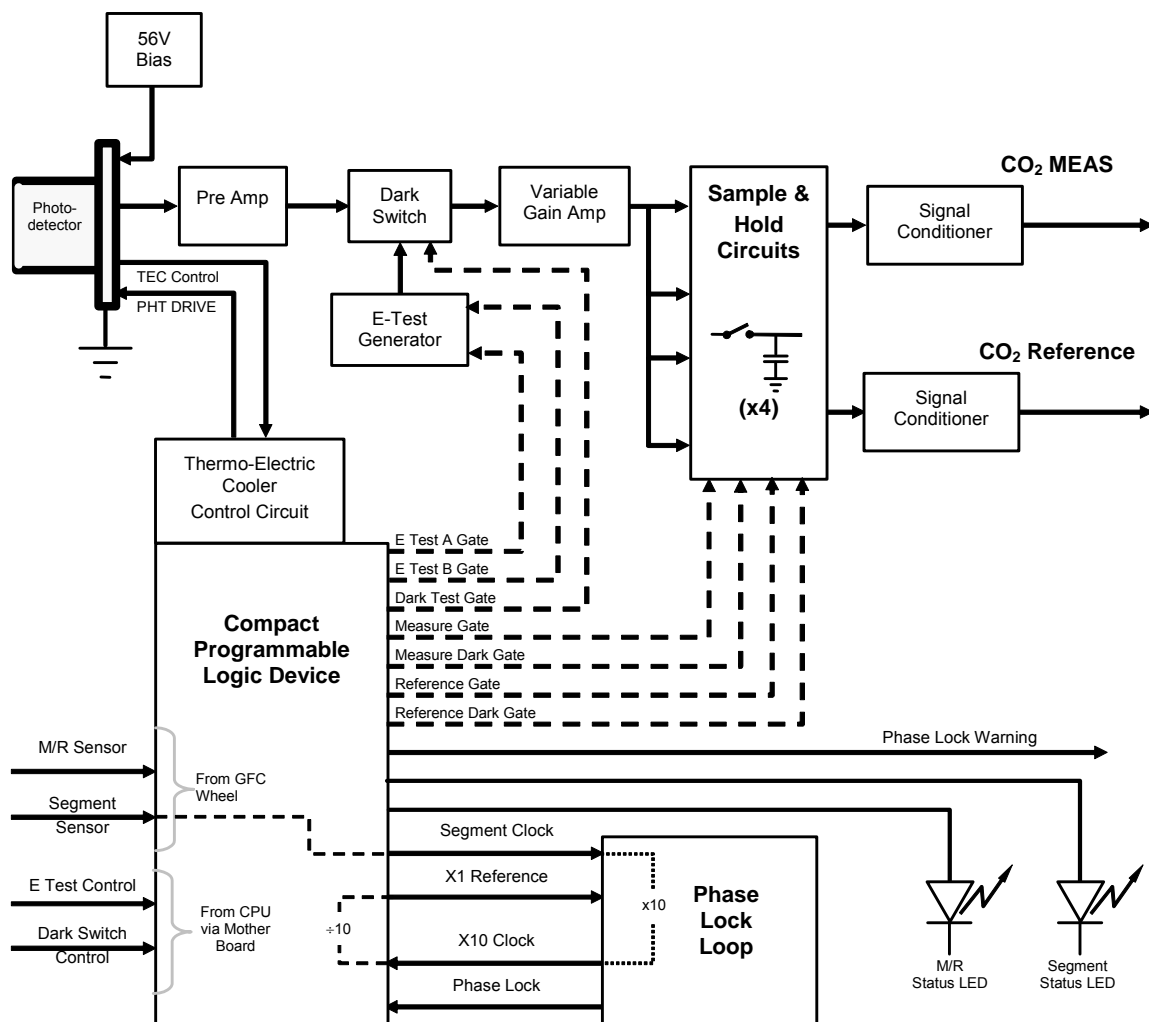

Figure 9-13: GFC 700T Sync / Demod Block Diagram

9.3.4.2. Signal Synchronization and Demodulation

The signal emitted by the IR photo-detector goes through several stages of amplification before it can be accurately demodulated. The first is a pre-amplification stage that raises the signal to levels readable by the rest of the sync/demod board circuitry. The second is a variable amplification stage that is adjusted at the factory to compensate for performance variations of mirrors, detectors, and other components of the optical bench from instrument to instrument.

The workhorses of the sync/demod board are the four sample-and-hold circuits that capture various voltage levels found in the amplified detector signal needed to determine the value of **CO2 MEAS** and **CO2 REF**. They are activated by logic signals under the control of a compact programmable logic device (PLD), which in turn responds to the output of the Segment Sensor and M/R Sensor described in Figure 10–11.

The four sample and hold circuits are:

DESIGNATION	ACTIVE WHEN:	
	IR BEAM PASSING THROUGH	SEGMENT SENSOR PULSE IS:
Measure Gate	MEASUREMENT cell of GFC Wheel	HIGH
Measure Dark Gate	MEASUREMENT cell of GFC Wheel	LOW
Reference Gate	REFERENCE cell of GFC Wheel	HIGH
Reference Dark Gate	REFERENCE cell of GFC Wheel	LOW

Timing for activating the Sample and Hold circuits is provided by a phase lock loop circuit (PLL). Using the segment sensor output as a reference signal the PLL generates clock signal at ten times that frequency. This faster clock signal is used by the PLD to make the sample and hold circuits capture the signal during the center portions of the detected waveform, ignore the rising and falling edges of the detector signal.

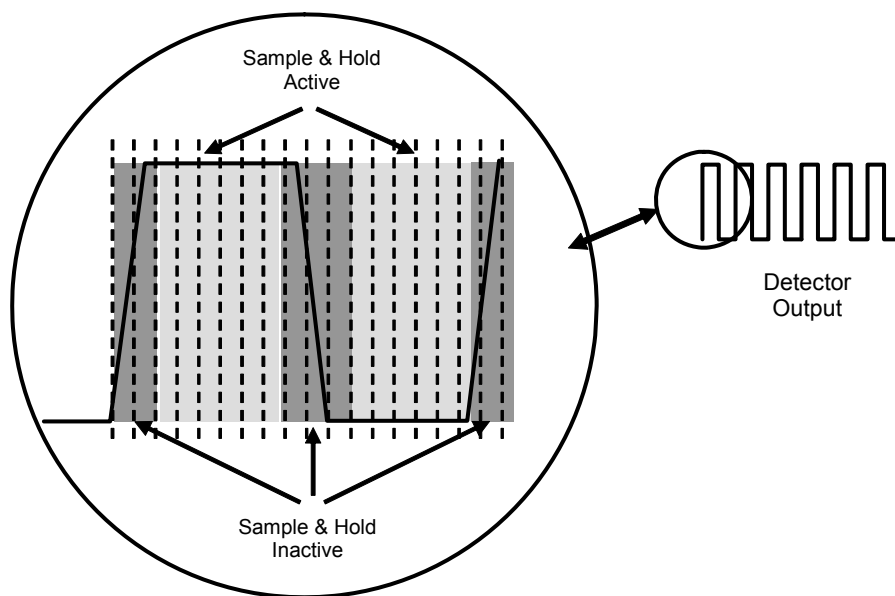

Figure 9-14: Sample & Hold Timing

9.3.4.3. Sync/Demod Status LED's

The following two status LED's located on the synch/demod board provide additional diagnostic tools for checking the GFC wheel rotation.

Table 9-1: Sync/Demod Status LED Activity

LED	FUNCTION	STATUS OK	FAULT STATUS
D1	M/R Sensor Status	LED flashes approximately 2/second	LED is stuck ON or OFF
D2	Segment Sensor Status	LED flashes approximately 6/second	LED is stuck ON or OFF

See Section 11.1.4 for more information.

9.3.4.4. Photo-Detector Temperature Control

The synch/demod board also contains circuitry that controls the IR photo-detector's thermoelectric coolers. A drive voltage, **PHT DRIVE**, is supplied to the coolers by the synch/demod board which is adjusted by the synch/demod board based on a return signal called TEC control which alerts informs the synch/demod board of the detector's temperature. The warmer the detector, the harder the coolers are driven.

PHT DRIVE is one of the Test Functions viewable by the user via the front panel. Press <**TST** or **TST**> until it appears on the display.

9.3.4.5. Dark Calibration Switch

This switch initiates the Dark Calibration procedure. When initiated by the user (See Section 6.13.6 for more details), the dark calibration process opens this switch, interrupting the signal from the IR photo-detector. This allows the analyzer to measure any offset caused by the synch/demod board circuitry.

9.3.4.6. Electric Test Switch

When active this circuit generates a specific waveform intended to simulate the function of the IR photo-detector but with a known set of value which is substituted for the detector's actual signal via the dark switch. It may also be initiated by the user (See Section 6.13.5 for more details).

9.3.5. Relay Board

By actuating various switches and relays located on this board, the CPU controls the status of other key components. The relay board receives instructions in the form of digital signals over the I²C bus, interprets these digital instructions and activates its various switches and relays appropriately.

9.3.5.1. Heater Control

The two heaters attached to the sample chamber housing and the GFC wheel motor are controlled by solid state relays located on the relay board.

The GFC wheel heater is simply turned on or off, however control of the bench heater also includes circuitry that selects which one of its two separate heating elements is activated depending on whether the instrument is running on 100 VAC, 115 VAC or 230 VAC line power.

9.3.5.2. GFC Wheel Motor Control

The GFC wheel operates from an AC voltage supplied by a multi-input transformer located on the relay board. The step-down ratio of this transformer is controlled by factory-installed jumpers to adjust for 100 VAC, 115 VAC or 230 VAC line power. Other circuitry slightly alters the phase of the AC power supplied to the motor during start up based on whether line power is 50Hz or 60 Hz.

Normally, the GFC Wheel Motor is always turning while the analyzer is on. A physical switch located on the relay board can be used to turn the motor off for certain diagnostic procedures.

9.3.5.3. Zero/Span Valve Options

Any zero/span valve options installed in the analyzer are controlled by a set of electronic switches located on the relay board. These switches, under CPU control, supply the +12VDC needed to activate each valve's solenoid.

9.3.5.4. IR Source

The Relay board supplies a constant 11.5VDC to the IR Source. Under normal operation the IR source is always on.

9.3.5.5. Status LEDs

Eight LEDs are located on the analyzer's relay board to show the current status on the various control functions performed by the relay board (see Figure 10-14). They are:

Table 9-2: Relay Board Status LED's

LED	COLOR	FUNCTION	STATUS WHEN LIT	STATUS WHEN UNLIT
D1	RED	Watchdog Circuit	Cycles On/Off Every 3 Seconds under direct control of the analyzer's CPU.	
D2	YELLOW	Wheel Heater	HEATING	NOT HEATING
D3	YELLOW	Bench Heater	HEATING	NOT HEATING
D4	YELLOW	Spare	N/A	N/A
D5	GREEN	Sample/Cal Gas Valve Option	Valve Open to CAL GAS FLOW	Valve Open to SAMPLE GAS FLOW
D6	GREEN	Zero/Span Gas Valve Option	Valve Open to SPAN GAS FLOW	Valve Open to ZERO GAS FLOW
D7	GREEN	Shutoff Valve Option	Valve Open to CAL GAS FLOW	Valve CLOSED to CAL GAS FLOW
D8	GREEN	IR SOURCE	Source ON	Source OFF



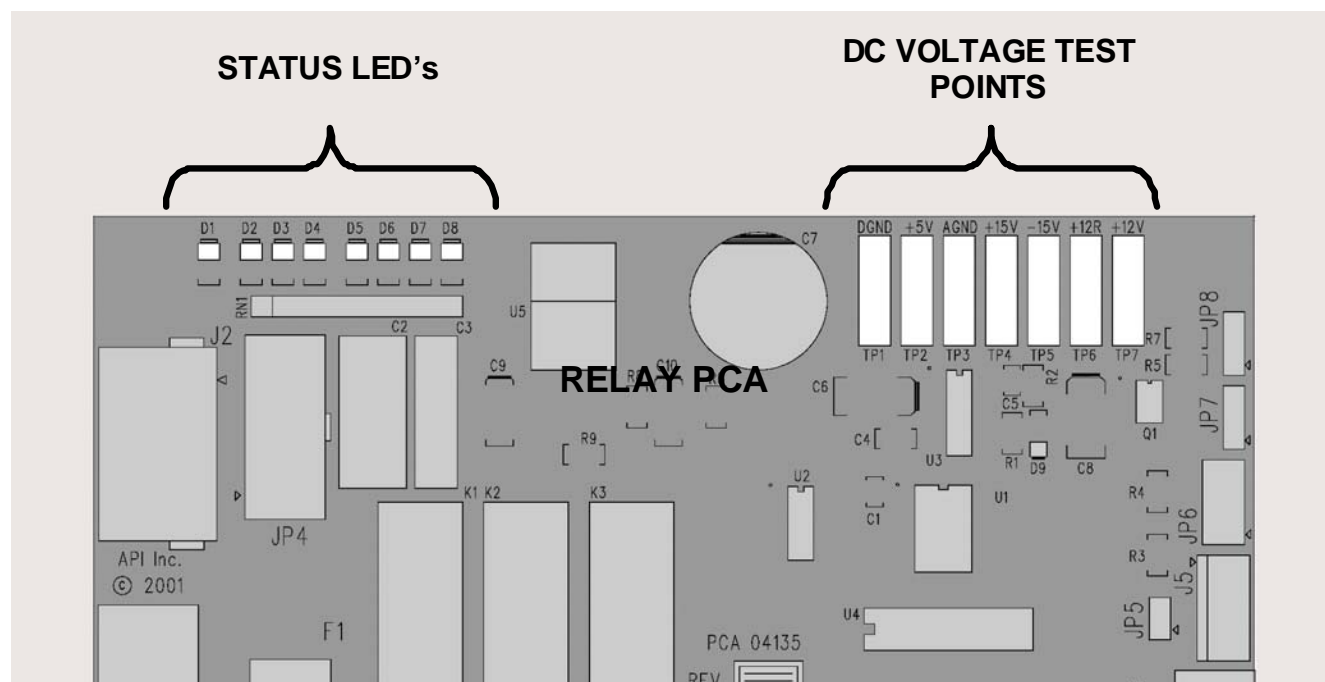

Figure 9-15: Location of relay board Status LED's

9.3.5.6. I²C Watch Dog Circuitry

Special circuitry on the relay board monitors the activity on the I²C bus and drives LED D1. Should this LED ever stay **ON** or **OFF** for 30 seconds, the watchdog circuit will automatically shut off all valves as well as turn off the IR Source and all heaters. The GFC wheel motor will still be running as will the Sample Pump, which is not controlled by the relay board.

9.3.6. Mother Board

This printed circuit assembly provides a multitude of functions including, A/D conversion, digital input/output, PC-104 to I2C translation, temperature sensor signal processing and is a pass through for the RS-232 and RS-485 signals.

9.3.6.1. A to D Conversion

Analog signals, such as the voltages received from the analyzer's various sensors, are converted into digital signals that the CPU can understand and manipulate by the analog to digital converter (A/D). Under the control of the CPU, this functional block selects a particular signal input (e.g. **BOX TEMP**, **CO2 MEAS**, **CO2 REF**, etc.) and then converts the selected voltage into a digital word.

The A/D consists of a voltage-to-frequency (V-F) converter, a programmable logic device (PLD), three multiplexers, several amplifiers and some other associated devices. The V-F converter produces a frequency proportional to its input voltage. The PLD counts the output of the V-F during a specified time period, and sends the result of that count, in the form of a binary number, to the CPU.

The A/D can be configured for several different input modes and ranges but in the GFC 7000T is used in uni-polar mode with a +5 V full scale. The converter includes a 1% over and under-range. This allows signals from -0.05 V to +5.05 V to be fully converted.

For calibration purposes, two reference voltages are supplied to the A/D converter: Reference Ground and +4.096 VDC. During calibration, the device measures these two voltages, outputs their digital equivalent to the CPU. The CPU uses these values to compute the converter's offset and slope and uses these factors for subsequent conversions.

See Section 6.13.4 for instructions on performing this calibration.

9.3.6.2. Sensor Inputs

The key analog sensor signals are coupled to the A/D through the master multiplexer from two connectors on the motherboard. 100K terminating resistors on each of the inputs prevent cross talk from appearing on the sensor signals.

CO₂ Measure and Reference

These are the primary signals that are used in the computation of the CO₂ concentration. They are the demodulated IR-sensor signals from the sync demodulator board.

Sample Pressure and Flow

These are analog signals from two sensors that measure the pressure and flow rate of the gas stream at the outlet of the sample chamber. This information is used in two ways. First, the sample pressure is used by the CPU to calculate CO₂ Concentration. Second, the pressure and flow rate are monitored as a test function to assist the user in predicting and troubleshooting failures.

9.3.6.3. Thermistor Interface

This circuit provides excitation, termination and signal selection for several negative-coefficient, thermistor temperature sensors located inside the analyzer. They are:

Sample Temperature Sensor

The source of this signal is a thermistor located inside the sample chamber of the Optical Bench. It measures the temperature of the sample gas in the chamber. This data is used to during the calculation of the CO₂ concentration value.

Bench Temperature Sensor

This thermistor, attached to the sample chamber housing, reports the current temperature of the chamber housing to the CPU as part of the bench heater control loop.

Wheel Temperature Sensor

This thermistor (attached to the heat-sync on the GFC wheel motor assembly) reports the current temperature of the wheel/motor assembly to the CPU as part of the Wheel Heater control loop.

Box Temperature Sensor

A thermistor is attached to the motherboard. It measures the analyzer's inside temperature. This information is stored by the CPU and can be viewed by the user for troubleshooting purposes via the front panel display (See Section 11.1.2).

9.3.6.4. Analog Outputs

The analyzer comes equipped with four analog outputs: A1, A2, A3 and A4. . In its standard configuration, the analyzer comes with all four of these channels set up to output a DC voltage. However, 4-20mA current loop drivers can be purchased for the first three of these outputs: A2, A2 & A3.

A2 and A1 Output

The first two, A2 and A1 are normally set up to operate in parallel so that the same data can be sent to two different recording devices. While the names imply that one should be used for sending data to a chart recorder and the other for interfacing with a data logger, either can be used for both applications.

Both of these channels output a signal that is proportional to the CO₂ concentration of the sample gas. The A1 and A2 outputs can be slaved together or set up to operated independently. A variety of scaling factors are available, See Section 6.13.4 for information on setting the range type and scaling factors for these output channels.

A3 Output

Analog output channel **A3** is only active when the O₂ sensor option is installed in the GFC 7000T. In this case, the currently measured O₂ concentration is output.

Test Function Output

The fourth analog output, labeled **A4** is special. It can be set by the user (See Section 6.9.9) to carry the current signal level of any one of the parameters accessible through the **SETUP → MORE → DIAG → TEST CHAN OUTPUT** submenu (See Section 6.13.9) of the unit's software.

Output Loop-back

All four analog outputs are connected back to the A/D converter through a Loop-back circuit. This permits the voltage outputs to be calibrated by the CPU without need for any additional tools or fixtures.

9.3.6.5. Internal Digital I/O

This channel is used to communicate digital status and control signals about the operation of key components of the Optical Bench. The CPU sends signals to the synch/demod board that initiate the **ELECTRICAL TEST** and **DARK CALIBRATION** procedures. Likewise, the synch/demod board uses this interface to send the **SYNC** warning signal to the CPU (See Sections 6.9.5, 6.9.6 and 11.1.1).

9.3.6.6. External Digital I/O

This External Digital I/O performs two functions: status outputs and control inputs.

Status Outputs

Logic-Level voltages are output through an optically isolated 8-pin connector located on the rear panel of the analyzer. These outputs convey good/bad and on/off information about certain analyzer conditions. They can be used to interface with certain types of programmable devices (See Section 6.13.1.1).

Control Inputs

By applying +5VDC power supplied from an external source such as a PLC or Data logger (See Section 6.13.1.2), Zero and Span calibrations can be initiated by contact closures on the rear panel.

9.3.7. I²C Data Bus

An I²C data bus is used to communicate data and commands between the CPU and the touchscreen/display interface and the relay board. I²C is a two-wire, clocked, digital serial I/O bus that is used widely in commercial and consumer electronic systems. A transceiver on the motherboard converts data and control signals from the PC-104 bus to I²C. The data is then fed to the touchscreen/display interface and finally onto the relay board.

Interface circuits on the touchscreen/display interface and relay boards convert the I²C data to parallel inputs and outputs. An additional, interrupt line from the touchscreen to the motherboard allows the CPU to recognize and service button presses on the touchscreen.

Power up Circuit

This circuit monitors the +5V power supply during start-up and sets the Analog outputs, external digital I/O ports, and I²C circuitry to specific values until the CPU boots and the instrument software can establish control.

9.3.8. Power Supply/ Circuit Breaker

The analyzer operates on 100 VAC, 115 VAC or 230 VAC power at either 50Hz or 60Hz. Individual units are set up at the factory to accept any combination of these five attributes. As illustrated in Figure 10-15, power enters the analyzer through a standard IEC 320 power receptacle located on the rear panel of the instrument. From there it is routed through the On/Off switch located in the lower right corner of the Front Panel. A 6.75 Amp circuit breaker is built into the ON/OFF Switch.

AC power is distributed directly to the sample gas pump. The bench and GFC wheel heaters as well as the GFC wheel receive AC power via the relay board.

AC Line power is converted stepped down and converted to DC power by two DC power supplies. One supplies +12 VDC, for valves and the IR source, while a second supply provides +5 VDC and ± 15 VDC for logic and analog circuitry. All DC voltages are distributed via the relay board.

	<p>CAUTION</p> <p>Should the AC power circuit breaker trip, investigate and correct the condition causing this situation before turning the analyzer back on.</p>
---	--

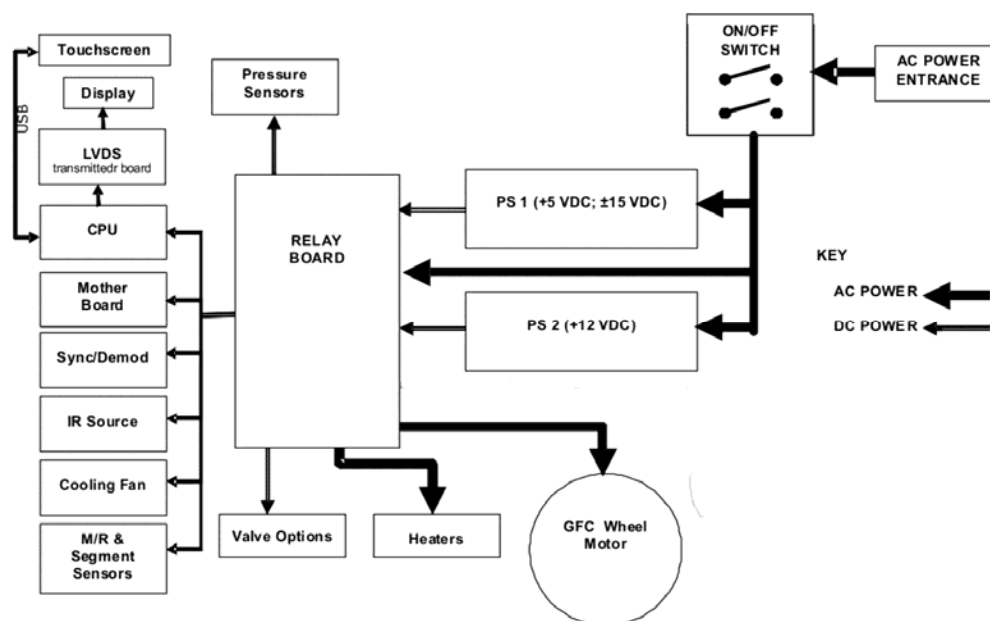

Figure 9-16: Power Distribution Block Diagram

9.4. Front Panel Touchscreen/Display Interface

Users can input data and receive information directly through the front panel touchscreen display. The LCD display is controlled directly by the CPU board. The touchscreen is interfaced to the CPU by means of a touchscreen controller that connects to the CPU via the internal USB bus and emulates a computer mouse.

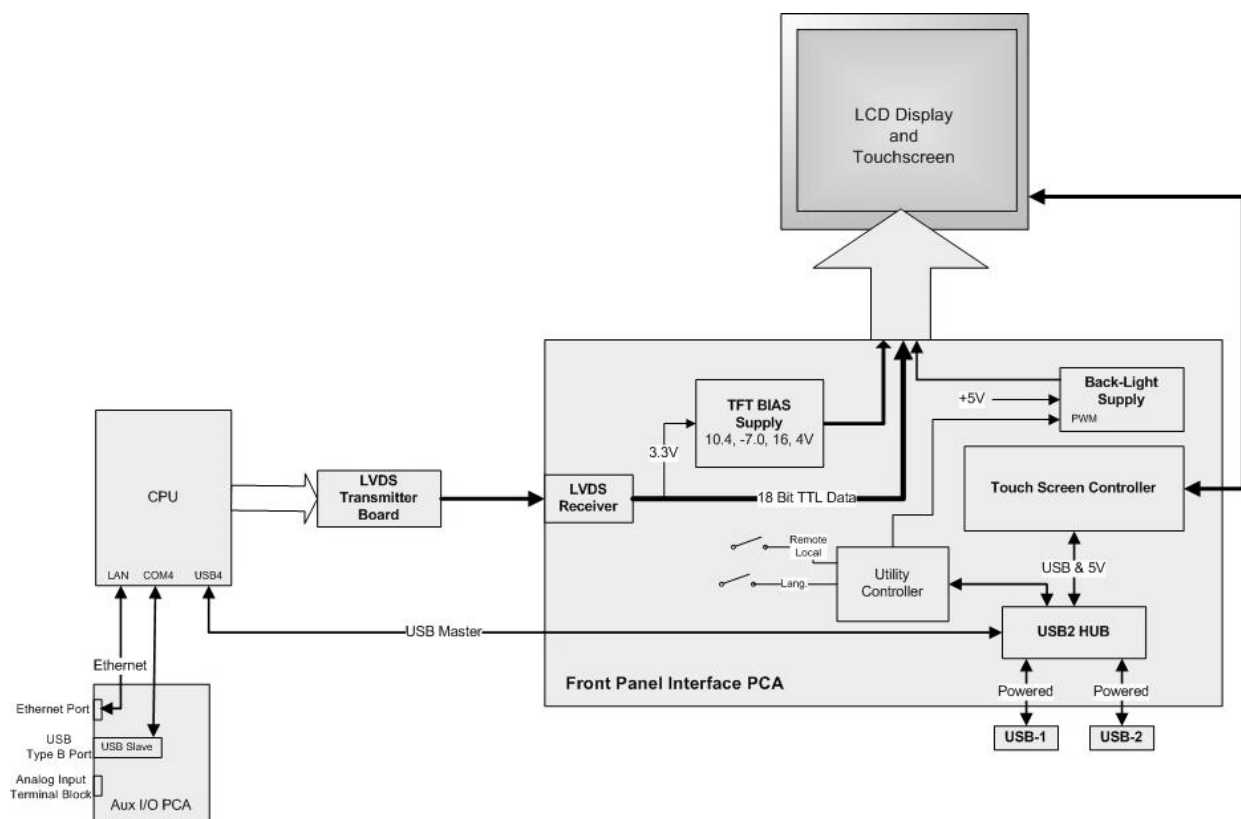

Figure 9-17: Front Panel and Display Interface Block Diagram

9.4.1. LVDS Transmitter Board

The LVDS (low voltage differential signaling) transmitter board converts the parallel display bus to a serialized, low voltage, differential signal bus in order to transmit the video signal to the LCD interface PCA.

9.4.2. Front Panel Touchscreen/Display Interface PCA

The front panel touchscreen/display interface PCA controls the various functions of the display and touchscreen. For driving the display it provides connection between the CPU video controller and the LCD display module. This PCA also contains:

- power supply circuitry for the LCD display module
- a USB hub that is used for communications with the touchscreen controller and the two front panel USB device ports
- the circuitry for powering the display backlight

9.5. Software Operation

The Model GFC 7000T Gas Filter Correlation Carbon Dioxide Analyzer has a high performance, VortexX86-based microcomputer running Windows CE. Inside Windows CE, special software developed by Teledyne Instruments interprets user commands via the various interfaces, performs procedures and tasks, stores data in the CPU's various memory devices and calculates the concentration of the sample gas.

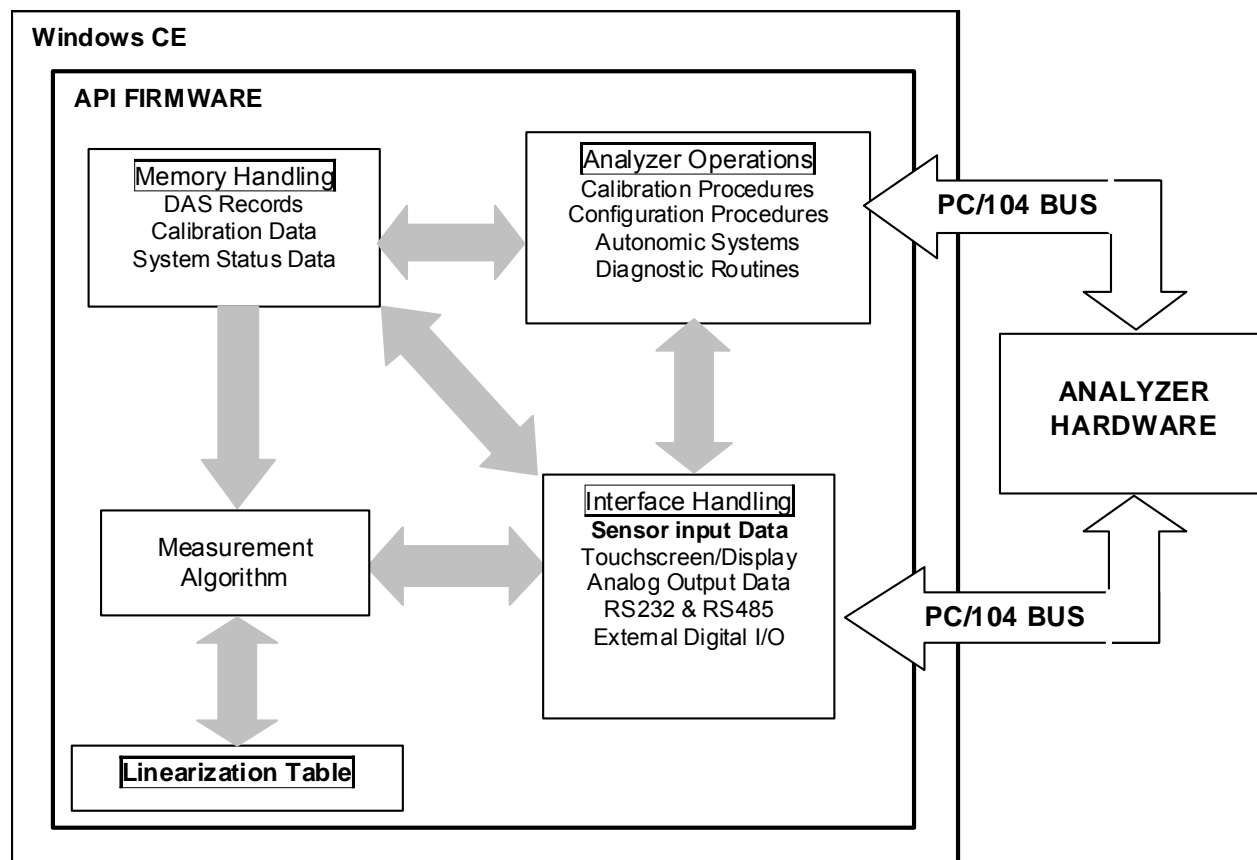

Figure 9-18: Basic Software Operation

9.5.1. Adaptive Filter

The GFC 7000T software processes the **CO2 MEAS** and **CO2 REF** signals, after they are digitized by the motherboard, through an adaptive filter built into the software. Unlike other analyzers that average the output signal over a fixed time period, the GFC 7000T averages over a set number of samples, where each sample is 0.2 seconds. This technique is known as boxcar averaging. During operation, the software automatically switches between two different length filters based on the conditions at hand. Once triggered, the short filter remains engaged for a fixed time period to prevent chattering.

During conditions of constant or nearly constant concentration the software, by default, computes an average of the last 750 samples, or approximately 150 seconds. This provides the calculation portion of the software with smooth stable readings. If a rapid change in concentration is detected the filter

includes, by default, the last 48 samples, approximately 10 seconds of data, to allow the analyzer to more quickly respond. If necessary, these boxcar lengths can be changed between 1 and 1000 samples but with corresponding tradeoffs in rise time and signal-to-noise ratio (contact customer service for more information).

Two conditions must be simultaneously met to switch to the short filter. First the instantaneous concentration must exceed the average in the long filter by a fixed amount. Second the instantaneous concentration must exceed the average in the long filter by a portion, or percentage, of the average in the long filter.

9.5.2. Calibration - Slope and Offset

Calibration of the analyzer is performed exclusively in software.

During instrument calibration (see Section 7) the user enters expected values for zero and span via the front panel touchscreen and commands the instrument to make readings of calibrated sample gases for both levels. The readings taken are adjusted, linearized, and compared to the expected values. With this information the software computes values for instrument slope and offset and stores these values in memory for use in calculating the CO₂ concentration of the sample gas.

The instrument slope and offset values recorded during the last calibration can be viewed by pressing the following touchscreen button sequence:

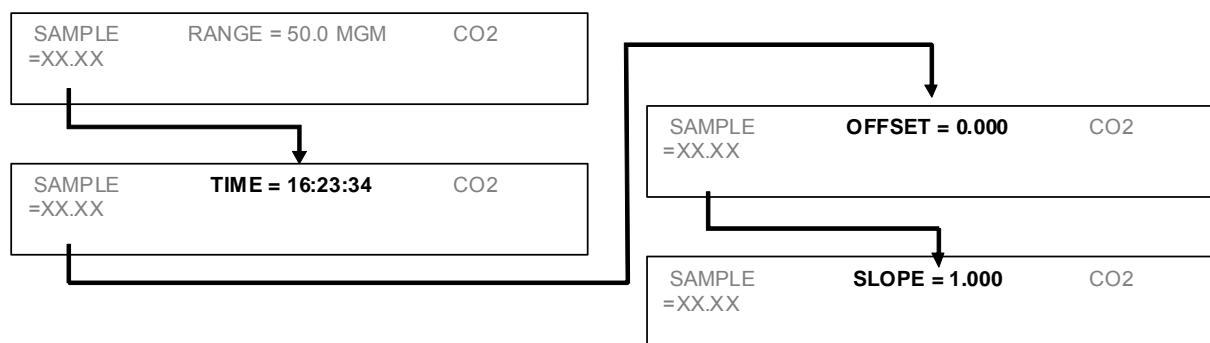

9.5.3. Measurement Algorithm

Once the IR photo-detector signal is demodulated into **CO2 MEAS** and **CO2 REF** by the sync/demod board and converted to digital data by the motherboard the GFC 7000T analytical software calculates the ratio between **CO2 MEAS** and **CO2 REF**. This value is compared to a look-up table is used, with interpolation, to linearize the response of the instrument. The linearized concentration value is combined with calibration slope and offset values, then normalized for changes in sample gas pressure to produce the final CO₂ concentration. This is the value that is displayed on the instrument front panel display and is stored in memory by the analyzer's DAS system.

9.5.4. Temperature and Pressure Compensation

Changes in pressure can have a noticeable effect on the CO₂ concentration calculation. To account for this, the Model GFC 7000T software includes a feature which allows the instrument to compensation of the CO₂ calculations based on changes in ambient pressure.

The TPC feature multiplies the analyzer's CO₂ concentration by a factor which is based on the difference between the ambient pressure of the sample gas normalized to standard atmospheric pressure. As ambient pressure increases, the compensated CO₂ concentration is increased.

9.5.5. Internal Data Acquisition System (DAS)

The DAS is designed to implement predictive diagnostics that stores trending data for users to anticipate when an instrument will require service. Large amounts of data can be stored in non-volatile memory and retrieved in plain text format for further processing with common data analysis programs. The DAS has a consistent user interface in all Teledyne Instruments analyzers. New data parameters and triggering events can be added to the instrument as needed.

Depending on the sampling frequency and the number of data parameters the DAS can store several months of data, which are retained even when the instrument is powered off or a new firmware is installed. The DAS permits users to access the data through the instrument's front panel or the remote interface. The latter can automatically download stored data for further processing. For information on using the DAS, refer to Sections 6.12.



10. TROUBLESHOOTING & REPAIR PROCEDURES

This contains a variety of methods for identifying the source of performance problems with the analyzer. Also included in this are procedures that are used in repairing the instrument.

	<p style="text-align: center;">CAUTION</p> <p style="text-align: center;">The operations outlined in this section are to be performed by qualified maintenance personnel only.</p>
---	--

	<p style="text-align: center;">CAUTION</p> <p style="text-align: center;">Risk of electrical shock. Disconnect power before performing the following operations.</p>
---	--

10.1. General Troubleshooting Hints

The analyzer has been designed so that problems can be rapidly detected, evaluated and repaired. During operation, the analyzer continuously performs self-check diagnostics and provides the ability to monitor the key operating parameters of the instrument without disturbing monitoring operations.

A systematic approach to troubleshooting will generally consist of the following four steps:

1. Note any **WARNING MESSAGES** and take corrective action as required.
2. Examine the values of all **TEST** functions and compare to factory values. Note any major deviations from the factory values and take correction action as required.
3. Use the internal electronic status LED's to determine whether the CPU and I²C buses are running, and if the sync/demodulator and relay board are operating properly. Verify that the DC power supplies are operating properly by checking the voltage test points on the relay board. Please note that the analyzer's DC power wiring is color-coded and these colors match the color of the corresponding test points on the relay board.
4. **SUSPECT A LEAK FIRST!** Data from Teledyne Instruments' service department indicates that 50% of all problems are eventually traced to leaks in the pneumatic connections and gas lines of the analyzer itself, the source of zero air, span gases or sample gas delivery system.

Check for gas flow problems such as clogged or blocked internal/external gas lines, damaged seals, punctured gas lines, etc.

5. Follow the procedures defined in Section 11.5 for confirming that the analyzer's basic components are working (power supplies, CPU, relay board, sync/demod board, touchscreen/display, GFC wheel motor, etc.). See Figure 3-3 for general layout of components and sub-assemblies in the analyzer. See the wiring list and diagram in Appendix D of this manual.

10.1.1. Interpreting WARNING Messages

The most common and/or serious instrument failures will result in a warning message being displayed on the front panel. Table 11-1 lists warning messages, along with their meaning and recommended corrective action.

It should be noted that if more than two or three warning messages occur at the same time, it is often an indication that some fundamental analyzer sub-system (power supply, relay board, motherboard) has failed rather than indication of the specific failures referenced by the warnings. In this case, it is recommended that proper operation of power supplies (See Section 10.5.2), the relay board (See Section 10.5.6), and the A/D Board (See Section 11.4.7.1) be confirmed before addressing the specific warning messages.

The analyzer will alert the user that a Warning message is active by flashing the FAULT LED and displaying the Warning message in the Param field along with the CLR button (press to clear Warning message). The MSG button displays if there is more than one warning in queue or if you are in the TEST menu and have not yet cleared the message. The following display/touchscreen examples provide an illustration of each:

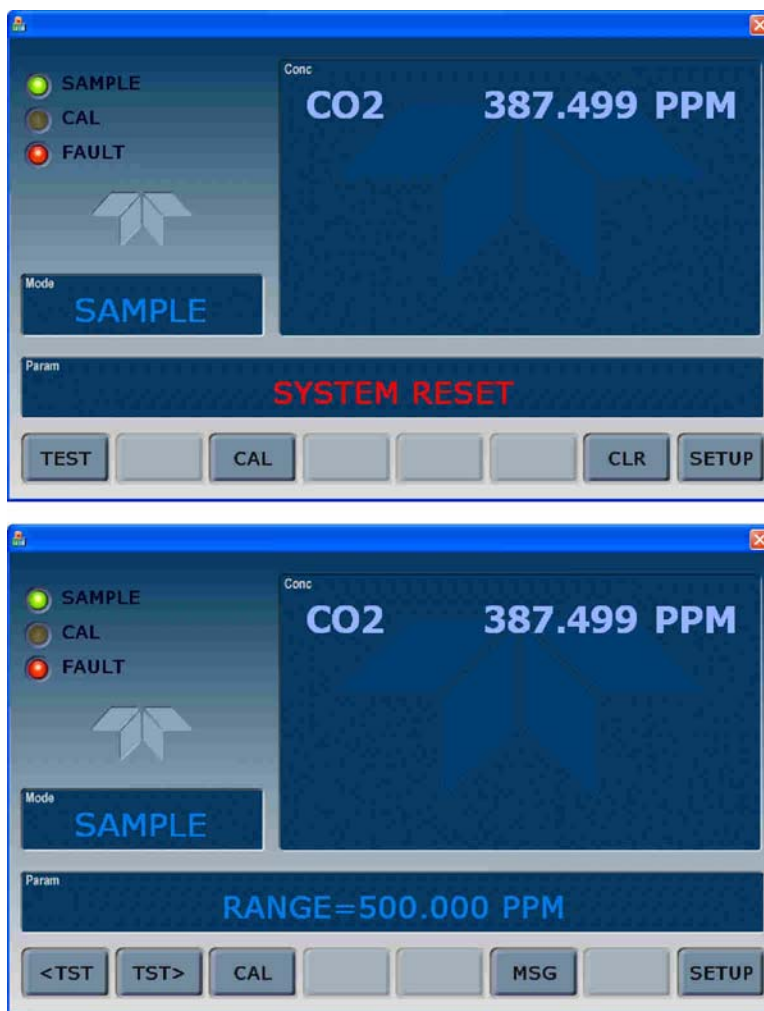

The analyzer will also alert the user via the Serial I/O COM port(s) and cause the FAULT LED on the front panel to blink.

To view or clear the various warning messages press:

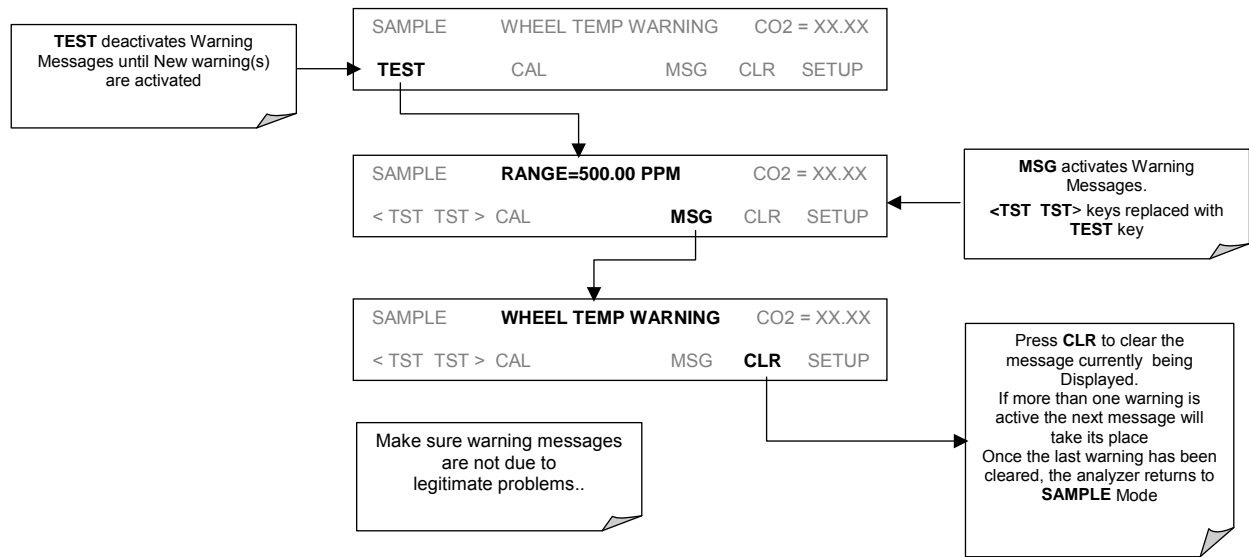

Figure 10-1: Viewing and Clearing Warning Messages

Table 10-1: Warning Messages - Indicated Failures

WARNING MESSAGE	FAULT CONDITION	POSSIBLE CAUSES
BENCH TEMP WARNING	The optical bench temp is controlled at 48 ± 2 °C.	Bad bench heater Bad bench temperature sensor Bad relay controlling the bench heater Entire relay board is malfunctioning I ² C bus malfunction
BOX TEMP WARNING	Box Temp is < 5 °C or > 48 °C.	NOTE: Box temperature typically runs ~7°c warmer than ambient temperature. Poor/blocked ventilation to the analyzer. Stopped exhaust-fan Ambient temperature outside of specified range
CANNOT DYN SPAN	Dynamic Span operation failed	Measured concentration value is too high or low. Concentration slope value to high or too low
CANNOT DYN ZERO	Dynamic Zero operation failed	Measured concentration value is too high. Concentration offset value to high.
CONFIG INITIALIZED	Configuration and Calibration data reset to original Factory state.	Failed disk on chip User erased data
CONC ALRM1 WARNING	Concentration alarm 1 is enabled and the measured CO ₂ level is ≥ the set point.	
CONC ALRM2 WARNING	Concentration alarm 2 is enabled and the measured CO ₂ level is ≥ the set point.	
DATA INITIALIZED	Data Storage in DAS was erased	Failed disk on chip User cleared data
PHOTO TEMP WARNING	PHT DRIVE is >4800 mVDC	Failed IR photo-detector Failed sync/demod board IR photo-detector improperly attached to the sample chamber Bench temp too high.
PURGE PRESS WARN	(GFC7000TU only) Purge pressure is outside of warning limits specified by the PURGE_PRESS_SET variable. Default limits are 2.5 to 12.5 PSIG.	Purge gas line blocked. Bad pressure regulator on line. Bad sensor/circuitry.
REAR BOARD NOT DET	Motherboard not detected on power up.	Warning only appears on serial i/o com port(s) Front panel display will be frozen, blank or will not respond. Massive failure of mother board
RELAY BOARD WARN	The CPU cannot communicate with the Relay Board.	I ² C bus failure Failed relay board Loose connectors/wiring
SAMPLE FLOW WARN	Sample flow rate is < 500 cc/min or > 1000 cc/min.	Failed sample pump Blocked sample inlet/gas line Dirty particulate filter Leak downstream of critical flow orifice Failed flow sensor/circuitry
SAMPLE PRES WARN	Sample Pressure is <10 in-Hg or > 35 in-Hg Normally 29.92 in-Hg at sea level decreasing at 1 in-Hg per 1000 ft of altitude (with no flow – pump disconnected).	If sample pressure is < 10 in-hg: <ul style="list-style-type: none"> o Blocked particulate filter o Blocked sample inlet/gas line o Failed pressure sensor/circuitry If sample pressure is > 35 in-hg: <ul style="list-style-type: none"> o Pressurized sample gas. Install vent o Blocked vent line on pressurized sample/zero/span gas supply o Bad pressure sensor/circuitry

Table 10-1: Warning Messages – Indicated Failures (cont.)

WARNING MESSAGE	FAULT CONDITION	POSSIBLE CAUSES
SAMPLE TEMP WARN	Sample temperature is < 10°C or > 100°C.	Ambient temperature outside of specified range Failed bench heater Failed bench temperature sensor Relay controlling the bench heater Failed relay board I ² C bus
SOURCE WARNING	Occurs when CO ₂ Ref is <1250 mVDC or >4950 mVDC. Either of these conditions will result in an invalid M/R ratio.	GFC wheel stopped Failed sync/demod board If status LED's on the sync/demod board <u>ARE</u> flashing the cause is most likely a failed: IR source Relay board I ² C bus IR photo-detector
SYSTEM RESET	The computer has rebooted.	This message occurs at power on. If you have not cycled the power on your instrument: <ul style="list-style-type: none"> o Failed +5 VDC power, o Fatal error caused software to restart o Loose connector/wiring
WHEEL TEMP WARNING	The filter wheel temperature is controlled at 68 ± 2 C	Blocked cooling vents below GFC Assembly. Make sure that adequate clear space beneath the analyzer. Analyzer's top cover removed Wheel heater Wheel temperature sensor Relay controlling the wheel heater Entire relay board I ² C bus

10.1.2. Fault Diagnosis with TEST Functions

Besides being useful as predictive diagnostic tools, the test functions viewable from the front panel can be used to isolate and identify many operational problems when combined with a thorough understanding of the analyzer's theory of operation (see Section 10).

The acceptable ranges for these test functions are listed in the "Nominal Range" column of the analyzer *Final Test and Validation Data Sheet* (p/n 04307) shipped with the instrument. Values outside these acceptable ranges indicate a failure of one or more of the analyzer's subsystems. Functions whose values are still within the acceptable range but have significantly changed from the measurement recorded on the factory data sheet may also indicate a failure. A worksheet has been provided in Appendix C to assist in recording the value of these test functions.

Table 11-2 contains some of the more common causes for these values to be out of range.

Table 10-2: Test Functions - Indicated Failures

TEST FUNCTIONS	INDICATED FAILURE(S)
TIME	Time of day clock is too fast or slow: To adjust See Section 6.6. Battery in clock chip on CPU board may be dead.
RANGE	Incorrectly configured measurement range(s) could cause response problems with a Data logger or chart recorder attached to one of the analog output. If the Range selected is too small, the recording device will over range. If the Range is too big, the device will show minimal or no apparent change in readings.
STABIL	Indicates noise level of instrument or CO ₂ concentration of sample gas (See Section 10.4.2 for causes).
CO ₂ MEAS & CO ₂ REF	If the value displayed is too high the IR Source has become brighter. Adjust the variable gain potentiometer on the sync/demod board If the value displayed is too low or constantly changing and the CO₂ REF is OK: <ul style="list-style-type: none"> o Failed multiplexer on the mother board o Failed sync/demod board o Loose connector or wiring on sync/demod board Flow of purge gas to the GFC wheel housing may have stopped If the value displayed is too low or constantly changing and the CO₂ REF is <u>BAD</u> : <ul style="list-style-type: none"> o GFC wheel stopped or rotation is too slow o Failed sync/demod board IR source o Failed IR source o Failed relay board o Failed I²C bus o Failed IR photo-detector
MR RATIO	When the analyzer is sampling zero air and the ratio is too low: <ul style="list-style-type: none"> o The reference cell of the GFC wheel is contaminated or leaking. o The alignment between the GFC wheel and the segment sensor, the M/R sensor or both is incorrect. o Failed sync/demod board o Flow of purge gas to the GFC wheel housing may have stopped When the analyzer is sampling zero air and the ratio is too high: <ul style="list-style-type: none"> o Zero air is contaminated o Failed IR photo-detector
PRES	See Table 11-1 for SAMPLE PRES WARN
SAMPLE FL	Check for gas flow problems. see Section 11.1.6
SAMPLE TEMP	SAMPLE TEMP should be close to BENCH TEMP . Temperatures outside of the specified range or oscillating temperatures are cause for concern
BENCH TEMP	Bench temp control improves instrument noise, stability and drift. Temperatures outside of the specified range or oscillating temperatures are cause for concern. See Table 11-1 for BENCH TEMP WARNING
WHEEL TEMP	Wheel temp control improves instrument noise, stability and drift. Outside of set point or oscillating temperatures are cause for concern. See Table 11-1 for WHEEL TEMP WARNING
BOX TEMP	If the box temperature is out of range, check fan in the power supply module. Areas to the side and rear of instrument should allow adequate ventilation. See Table 11-1 for BOX TEMP WARNING .
PHT DRIVE	If this drive voltage is out of range it may indicate one of several problems: <ul style="list-style-type: none"> - A poor mechanical connection between the various components in inside the detector housing - An electronic failure of the IR Photo-Detector's built-in cooling circuitry, or; - A temperature problem inside the analyzer chassis. In this case other temperature warnings would also be active such as BENCH TEMP WARNING or BOX TEMP WARNING.

TEST FUNCTIONS	INDICATED FAILURE(S)
SLOPE	Values outside range indicate Contamination of the zero air or span gas supply Instrument is miss-calibrated Blocked gas flow Contaminated or leaking GFC wheel (either chamber) Faulty IR photo-detector Faulty sample faulty IR photo-detector pressure sensor (P1) or circuitry Invalid M/R ratio (see above) Bad/incorrect span gas concentration due.
OFFSET	Values outside range indicate Contamination of the zero air supply Contaminated or leaking GFC wheel (either chamber) Faulty IR photo-detector

10.1.3. Using the Diagnostic Signal I/O Function

The Signal I/O parameters found under the DIAG Menu (See Section 6.9.2 and Appendix A) combined with a thorough understanding of the instrument’s Theory of Operation (found in Section 10) are useful for troubleshooting in three ways:

- The technician can view the raw, unprocessed signal level of the analyzer’s critical inputs and outputs.
- All of the components and functions that are normally under algorithmic control of the CPU can be manually exercised.
- The technician can directly control the signal level of the Analog and Digital Output signals.

This allows the technician to systematically observe the effect of directly controlling these signals on the operation of the analyzer. Below in Figure 11-2 is an example of how to use the signal I/O menu to view the raw voltage of an input signal or to control the state of an output voltage or control signal. The specific parameter will vary depending on the situation.

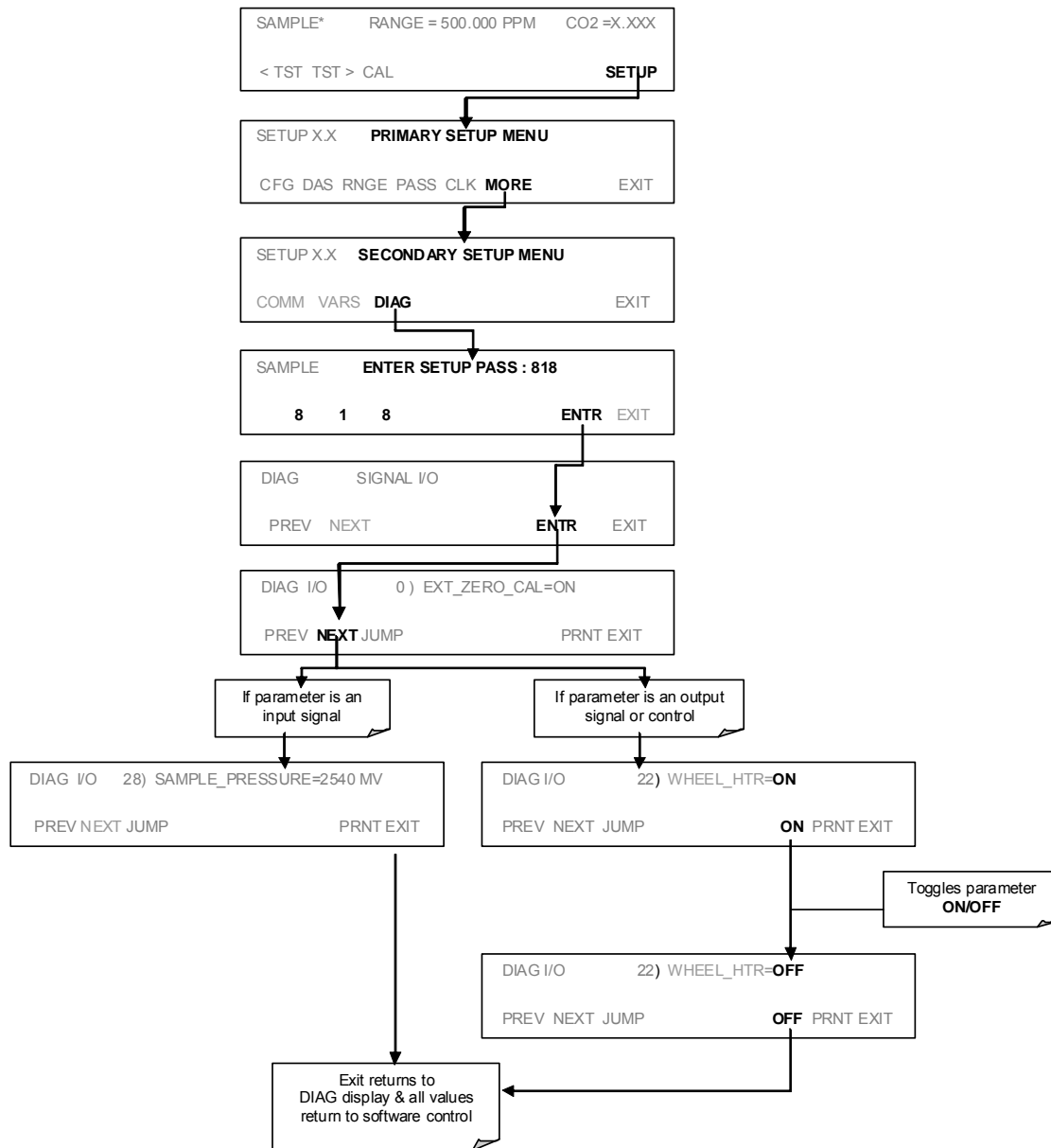

Figure 10-2: Example of Signal I/O Function

10.1.4. Internal Electronic Status LEDs

Several LED's are located inside the instrument to assist in determining if the analyzer's CPU, I²C bus and relay board, GFC wheel and the sync/demodulator board are functioning properly.

10.1.4.1. CPU Status Indicator

DS5, a red LED, that is located on upper portion of the motherboard, just to the right of the CPU board, flashes when the CPU is running the main program loop. After power-up, approximately 30 to 60

seconds, DS5 should flash on and off. If characters are written to the front panel display but DS5 does not flash then the program files have become corrupted. If after 30 – 60 seconds neither the DS5 is flashing or no characters have been written to the front panel display then the CPU is bad and must be replaced.

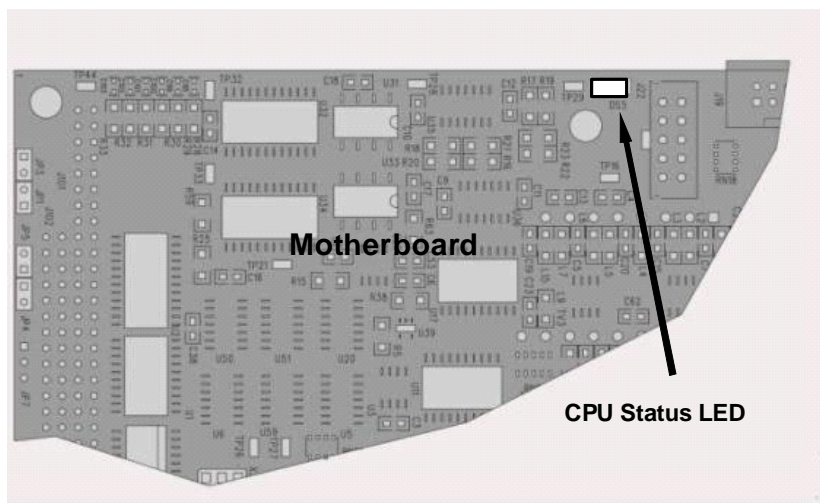

Figure 10-3: CPU Status Indicator

10.1.4.2. Sync Demodulator Status LED's

Two LEDs located on the Sync/Demod Board and are there to make it obvious that the GFC Wheel is spinning and the synchronization signals are present:

Table 10-3: Sync/Demod Board Status Failure Indications

LED	FUNCTION	FAULT STATUS	INDICATED FAILURE(S)
D1	M/R Sensor Status (Flashes slowly)	LED is stuck ON or OFF	GFC Wheel is not turning M/R Sensor on Opto-Pickup Board failed Sync/Demod Board failed JP 4 Connector/Wiring faulty Failed/Faulty +5 VDC Power Supply (PS1)
D2	Segment Sensor Status (Flashes quickly)	LED is stuck ON or OFF	GFC Wheel is not turning Segment Sensor on Opto-Pickup Board failed Sync/Demod Board failed JP 4 Connector/Wiring faulty Failed/Faulty +5 VDC Power Supply (PS1)

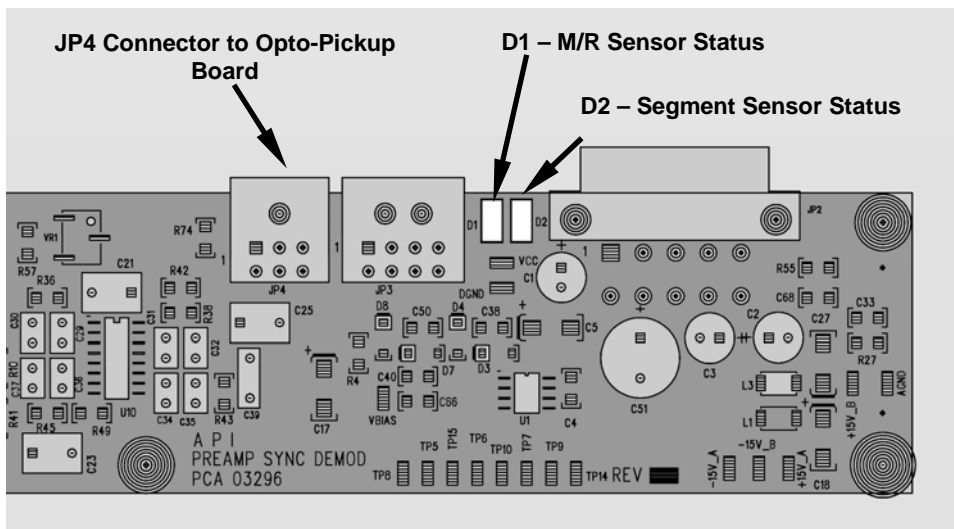

Figure 10-4: Sync/Demod Board Status LED Locations

10.1.4.3. Relay Board Status LEDs

There are eight LEDs located on the Relay Board. The most important of which is D1 is the most important LED, which indicates the health of the I²C bus. If D1 is blinking the other faults following LEDs can be used in conjunction with **DIAG** menu signal I/O to identify hardware failures of the relays and switches on the relay (See Section 6.9.2 and Appendix D).

Table 10-4: I2C Status LED Failure Indications

LED	FUNCTION	FAULT STATUS	INDICATED FAILURE(S)
D1 (Red)	I ² C bus Health (Watchdog Circuit)	Continuously ON or Continuously OFF	Failed/Halted CPU Faulty Motherboard, or Relay Board Faulty Connectors/Wiring to/from Relay Board Failed/Faulty +5 VDC Power Supply (PS1)

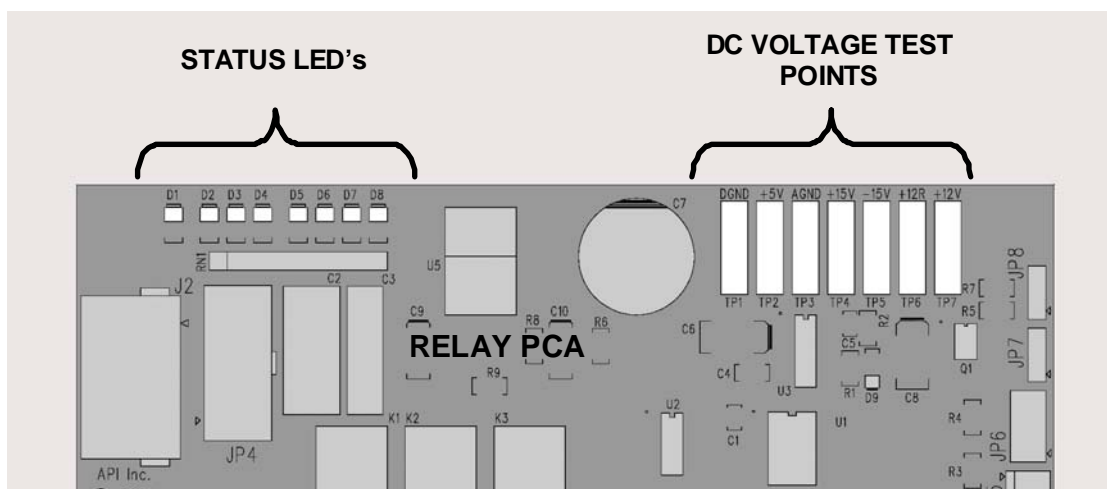

Figure 10-5: Relay Board Status LEDs

Table 10-5: Relay Board Status LED Failure Indications

LED	FUNCTION	SIGNAL I/O PARAMETER		DIAGNOSTIC TECHNIQUE
		ACTIVATED BY	VIEW RESULT	
D2 Yellow	WHEEL HEATER	WHEEL_HEATER	WHEEL_TEMP	Voltage displayed should change. If not: Failed Heater Faulty Temperature Sensor Failed AC Relay Faulty Connectors/Wiring
D3 Yellow	BENCH HEATER	BENCH_HEATER	BENCH_TEMP	Voltage displayed should change. If not: Failed Heater Faulty Temperature Sensor Failed AC Relay Faulty Connectors/Wiring
D4 Yellow	SPARE	N/A	N/A	N/A
D5 Green	SAMPLE/CAL GAS VALVE OPTION	CAL_VALVE	N/A	Sample/Cal Valve should audibly change states. If not: Failed Valve Failed Relay Drive IC on Relay Board Failed Relay Board Faulty +12 VDC Supply (PS2) Faulty Connectors/Wiring
D6 Green	ZERO/SPAN GAS VALVE OPTION	SPAN_VALVE	N/A	Zero/Span Valve should audibly change states. If not: Failed Valve Failed Relay Drive IC on Relay Board Failed Relay Board Faulty +12 VDC Supply (PS2) Faulty Connectors/Wiring
D7 Green	SHUTOFF VALVE OPTION	SHUTOFF_VALVE	N/A	Shutoff Valve should audibly change states. If not: Failed Valve Failed Relay Drive IC on Relay Board Failed Relay Board Faulty +12 VDC Supply (PS2) Faulty Connectors/Wiring
D8 Green	IR SOURCE	IR_SOURCE	CO ₂ _MEASURE	Voltage displayed should change. If not: Failed IR Source Faulty +12 VDC Supply (PS2) Failed Relay Board Failed IR Photo-Detector Failed Sync/Demod Board Faulty Connectors/Wiring

10.2. Gas Flow Problems

The GFC 7000T has two main gas flow paths, the sample gas flow path and the GFC purge gas flow path. The purge path is controlled by a critical flow orifice, the sample path is not. Only the sample gas path is measured and reported. When the IZS or zero/span valve options are installed, there are several subsidiary paths but none of those are displayed on the front panel or stored by the DAS.

With the O₂ sensor option installed, third gas flow controlled with a critical flow orifice is added, but this flow is not measured or reported.

In general, flow problems can be divided into three categories:

- Flow is too high
- Flow is greater than zero, but is too low, and/or unstable
- Flow is zero (no flow)

When troubleshooting flow problems, it is crucial to confirm the actual flow rate without relying on the analyzer's flow display. The use of an independent, external flow meter to perform a flow check as described in Section 9.3.4 is essential. If this test shows the flow to be correct, check the pressure sensors as described in Section 11.5.6.5.

The flow diagrams provided in this manual depicting the GFC 7000T in its standard configuration and with options installed can help in troubleshooting flow problems. For your convenience they are collected here.



10.2.1. GFC 7000T Internal Gas Flow Diagrams

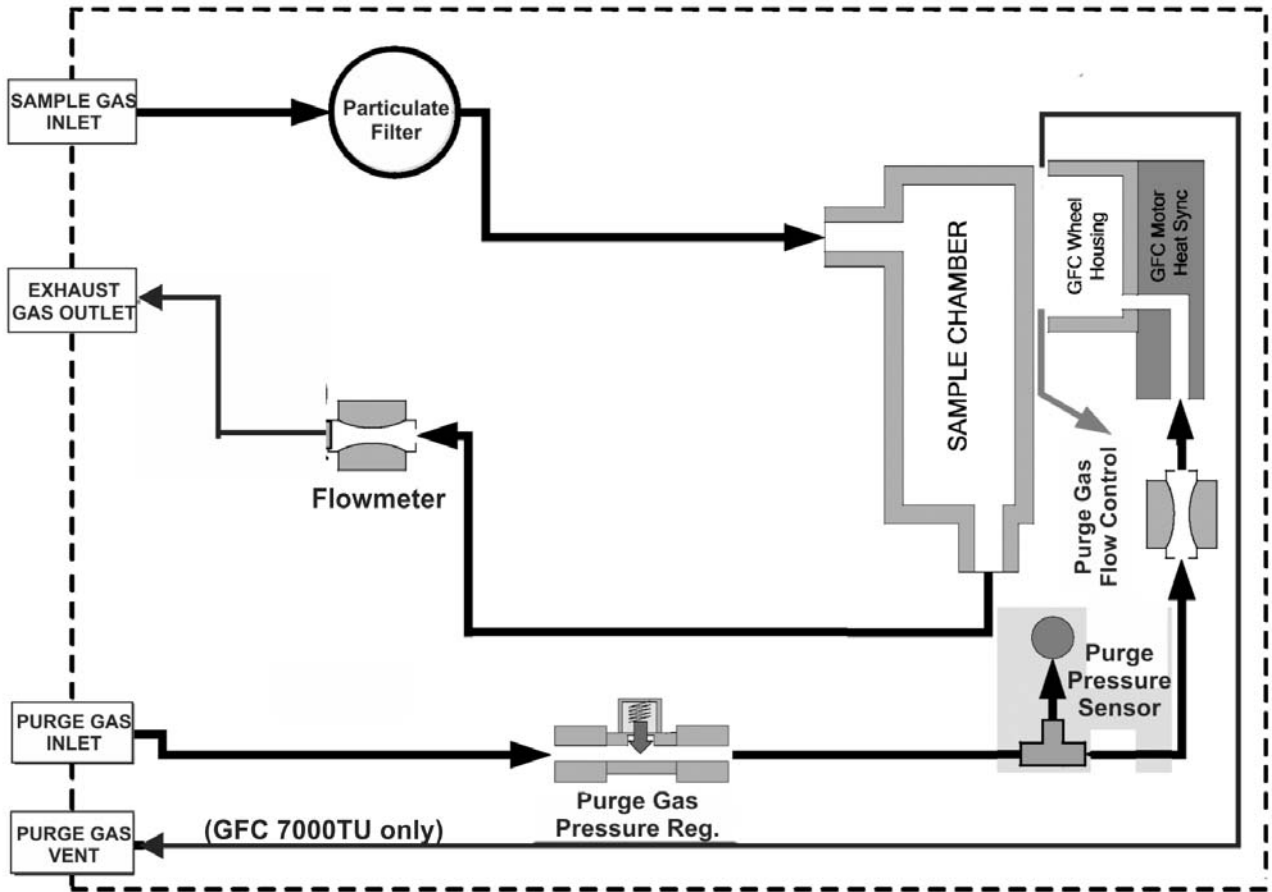

Figure 10-6: GFC 7000T – Basic Internal Gas Flow

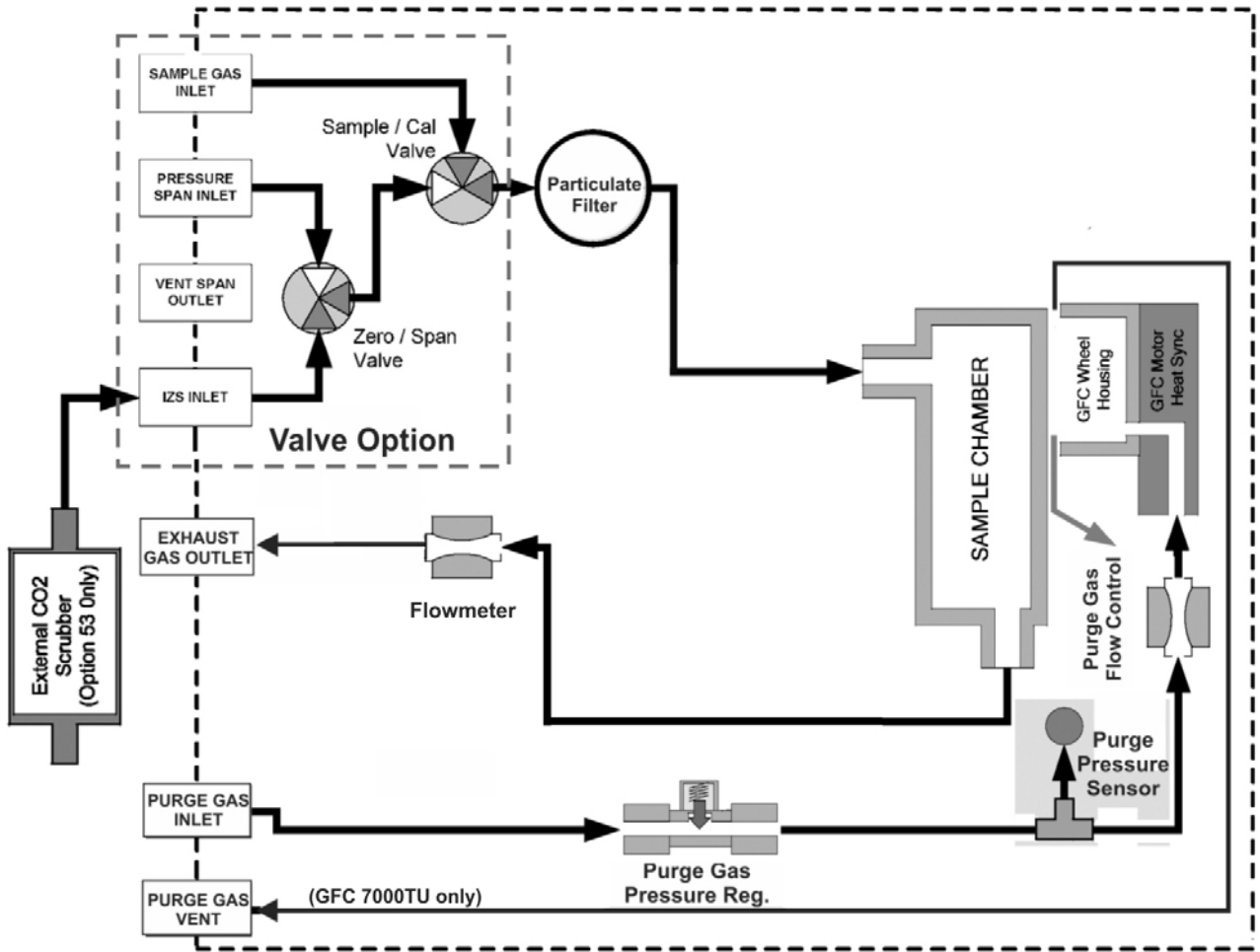

Figure 10-7: Internal Pneumatic Flow –Zero/Span Valves

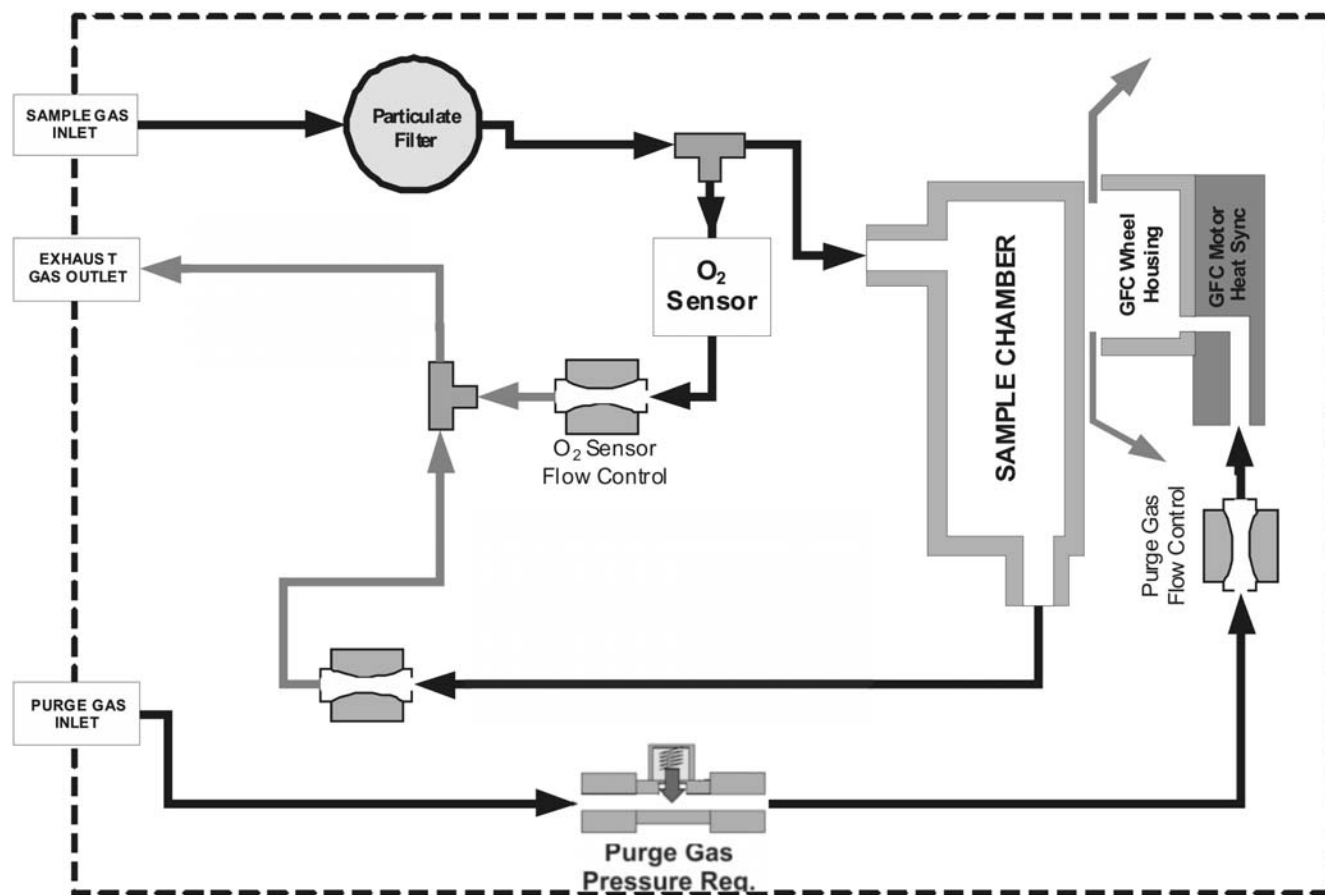

Figure 10-8: Internal Pneumatic Flow – with O₂ Sensor Option 65A

10.2.2. Typical Sample Gas Flow Problems

10.2.2.1. Flow is Zero

The unit displays a **SAMPLE FLOW** warning message on the front panel display or the **SAMPLE FLOW** test function reports a zero or very low flow rate.

Confirm that the sample gas is connected correctly and is free to flow.

- Make sure that the unit is in basic SAMPLE Mode.
- Place a finger over an Exhaust outlet on the rear panel of the instrument.
- If gas is flowing through the analyzer, you will feel flow from the Exhaust outlet.
- Gas bottles are not empty or low.
- Valves, regulators and gas lines are not clogged or dirty.

10.2.2.2. Low Flow

1. Check for leaks as described in Section 8.3.2. Repair the leaking fitting, line or valve and re-check.
2. Check for the sample filter and the orifice filter for dirt. Replace filters (See Section 8.3.1).
3. Check for partially plugged pneumatic lines, orifices, or valves. Clean or replace them.
4. If an IZS option is installed in the instrument, press **CALZ** and **CALS**. If the flow increases then suspect a bad sample/cal valve.

10.2.2.3. High Flow

The most common cause of high flow is problems in the sample flow control device(s) installed by the user. Refer to the documentation supplied with these devices for appropriate action.

10.2.2.4. Displayed Flow = “XXXX”

This warning means that there is inadequate gas flow. There are four conditions that might cause this:

1. A leak upstream or downstream of the flow sensor
2. A flow obstruction upstream or downstream of the flow sensor
3. Bad Flow Sensor Board

To determine which case it is, view the sample pressure and sample flow functions via the front panel. If the sample pressure is reading abnormally low, then the cause is likely a flow obstruction upstream of the flow sensor. First, check the sample filter and make sure it is not plugged and then systematically check all the other components upstream of the orifice to ensure that they are not obstructed.

If the sample pressure is reading normal but the sample flow is reading low then it is likely that there is an obstruction downstream of the flow sensor.

10.2.2.5. Actual Flow Does Not Match Displayed Flow

If the actual flow measured does not match the displayed flow, but is within the limits of 720-880 cc/min, adjust the calibration of the flow measurement as described in Section 6.9.8.

10.2.3. Poor or Stopped Flow of Purge Gas

If sufficient purge gas is not supplied to the GFC wheel housing, cyclical fluctuations in readings at zero or low CO₂ concentrations, such as < 100 ppm, may occur. These fluctuations are the result of changes in the CO₂ concentration of the ambient atmosphere throughout the course of the day and night. In isolated areas with relatively few people working nearby the ambient CO₂ concentration will fall during the day and rise during the night as rate of photosynthesis of the plants in the surrounding area decreases and increases. In a lab environment with a relatively high human occupancy the ambient CO₂ concentration will increase during those parts of the day when the highest number of workers are present. If the GFC wheel housing is allowed to fill with ambient air, these natural, diurnal fluctuations might be detected by the instrument and cause it's in its calculation of the CO₂ concentration of the sample gas to drift.

Another possible symptom of poor or stopped purge gas flow would be the inability to measure zero concentrations accurately at the end of a work day on a system that was calibrated at the beginning of a workday. Although this could also be due to local fluctuations in ambient CO₂ concentration during the day.

10.3. Calibration Problems

10.3.1. Miscalibrated

There are several symptoms that can be caused by the analyzer being miss-calibrated. This condition is indicated by out of range Slopes and Offsets as displayed through the test functions and is frequently caused by the following:

1. **BAD SPAN GAS.** This can cause a large error in the slope and a small error in the offset. Delivered from the factory, the GFC 7000T's slope is within $\pm 15\%$ of nominal. Bad span gas will cause the analyzer to be calibrated to the wrong value. If in doubt have the span gas checked by and independent lab.
2. **CONTAMINATED ZERO GAS.** Excess H₂O can cause a positive or negative offset and will indirectly affect the slope.
3. **Dilution calibrator not set up correctly or is malfunctioning.** This will also cause the slope, but not the zero, to be incorrect. Again the analyzer is being calibrated to the wrong value.
4. **Too many analyzers on the manifold.** This can cause either a slope or offset error because ambient gas with its pollutants will dilute the zero or span gas.



10.3.2. Non-Repeatable Zero and Span

As stated earlier, leaks both in the GFC 7000T and in the external system are a common source of unstable and non-repeatable readings.

1. Check for leaks in the pneumatic systems as described in Section 8.3.2. Don't forget to consider pneumatic components in the gas delivery system outside the GFC 7000T. Such as:
 - A change in zero air source such as ambient air leaking into zero air line, or;
 - A change in the span gas concentration due to zero air or ambient air leaking into the span gas line.
2. Once the instrument passes a leak check, do a flow check (See Section 9.3.4) to make sure adequate sample is being delivered to the sensor assembly.
3. A failing IR photo-detector may be at fault. Check the **CO2 MEAS** and **CO2 REF** test functions via the front panel display to make sure the signal levels are in the normal range (See Appendix A) and are quiet.
4. Confirm the sample pressure, wheel temperature, bench temperature, and sample flow readings are correct and have steady readings.
5. Disconnect the exhaust line from the optical bench near the rear of the instrument and plug this line into the **SAMPLE** inlet creating a pneumatic loop. The CO₂ concentration (either zero or span) now must be constant. If readings become quiet, the problem is in the external pneumatics supplies for sample gas, span gas or zero air.
6. If it is the zero point that is non-repeatable, and if that non-repeatability seems to only occur at a certain time of day, such as when worker occupancy is highest or lowest, make sure the flow of purge gas to the GFC wheel housing has not stopped (See Sections 10.2.2 and 11.1.7 for more information).

10.3.3. Inability to Span – Touchscreen SPAN Button Not Visible

1. Confirm that the carbon dioxide span gas source is accurate; this can be done by switching between two span-gas tanks. If the CO₂ concentration is different, there is a problem with one of the tanks.
2. Check for leaks in the pneumatic systems as described in Section 8.3.2.
3. Make sure that the expected span gas concentration entered into the instrument during calibration is the correct span gas concentration and not too different from expected span value. This can be viewed via the **RNG** Menu (See Section 6.7).
4. Check to make sure that there is no ambient air or zero air leaking into span gas line.

10.3.4. Inability to Zero – Touchscreen ZERO Button Not Visible

1. Confirm that there is a good source of zero air. Dilute a tank of span gas with the same amount of zero air from two different sources. If the CO₂ Concentration of the two measurements is different, there is a problem with one of the sources of zero air.
2. Check for leaks in the pneumatic systems as described in Section 8.3.2.



3. If the analyzer has had zero/span valve options 52 or 53, the CO₂ scrubber may need maintenance.
4. Check to make sure that there is no ambient air leaking into zero air line.

10.4. Other Performance Problems

Dynamic problems (i.e. problems which only manifest themselves when the analyzer is monitoring sample gas) can be the most difficult and time consuming to isolate and resolve. The following provides an itemized list of the most common dynamic problems with recommended troubleshooting checks and corrective actions.

10.4.1. Temperature Problems

Individual control loops are used to maintain the set point of the absorption bench, filter wheel, and IR photo-detector temperatures. If any of these temperatures are out of range or are poorly controlled, the GFC 7000T will perform poorly.

10.4.1.1. Box or Sample Temperature

Box Temperature

The box temperature sensor is mounted to the motherboard and cannot be disconnected to check its resistance. Rather check the **BOX TEMP** signal using the **SIGNAL I/O** function under the **DIAG** Menu (See Section 10.1.3). This parameter will vary with ambient temperature, but at ~30°C (6-7° above room temperature) the signal should be ~1450 mV.

Sample Temperature

The Sample Temperature should closely track the bench temperature. If it does not, locate the sensor, which is located at the midpoint of the optical bench in a brass fitting. Unplug the connector labeled "Sample", and measure the resistance of the thermistor; at room temperature (25°C) it should be ~30K Ohms, at operating temperature, 48°C, it should be ~ 12K Ohms

10.4.1.2. Bench Temperature

There are three possible failures that could cause the Bench temperature to be incorrect.

1. The heater mounted to the bottom of the Absorption bench is electrically shorted or open. Check the resistance of the two heater elements by measuring between pin 2 and 4 (~76 Ohms), and pin 3 and 4 (~330 Ohms), of the white five-pin connector just below the sample temperature sensor on the Bench (pin 1 is the pointed end).
2. Assuming that the I²C bus is working and that there is no other failure with the relay board, the solid-state relay (K2) on the relay board may have failed. Using the **BENCH_HEATER** parameter under the signal I/O function, as described above, turn on and off K2 (D3 on the relay board should illuminate as the heater is turned on). Check the AC voltage present between pin 2 and 4, for a 100 or 115 VAC model, and pins 3 and 4, for a 220-240 VAC model.

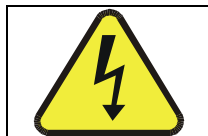

WARNING:

HAZARDOUS VOLTAGES ARE PRESENT DURING THIS TEST

3. If the relay has failed there should be no change in the voltage across pins 2 and 4 or 3 and 4. NOTE: K2 is in a socket for easy replacement.
4. If K2 checks out OK, the thermistor temperature sensor located on the optical bench near the front of the instrument could be at fault. Unplug the connector labeled “Bench”, and measure the resistance of the thermistor. At room temperature it should have approximately 30K Ohms resistance near the 48°C set point it should have ~12K ohms.

10.4.1.3. GFC Wheel Temperature

Like the bench heater above there are three possible causes for the GFC wheel temperature to have failed.

1. The wheel heater has failed. Check the resistance between pins 1 and 4 on the white five-pin connector just below the sample temperature sensor on the bench (pin 1 is the pointed end). It should be approximately 275 ohms.
2. Assuming that the I²C bus is working and that there is no other failure with the relay board, the solid-state relay (K1) on the relay board may have failed. Using the **WHEEL_HEATER** parameter under the signal I/O function, as described above, turn on and off K1 (D2 on the relay board should illuminate as the heater is turned on). Check the AC voltage present between Pin 1 and Pin 4.

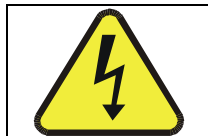

WARNING:

HAZARDOUS VOLTAGES ARE PRESENT DURING THIS TEST

3. If the relay has failed there should be no change in the voltage across pins 1 and 4. NOTE: K1 is socketed for easy replacement.
4. If K1 checks out OK, the thermistor temperature sensor located at the front of the filter wheel assembly may have failed. Unplug the connector labeled “Wheel”, and measure the resistance of the thermistor. The resistance near the 68°C set point is ~5.7k ohms.

10.4.1.4. IR Photo-Detector TEC Temperature

If the **PHT DRIVE** test parameter described above in Table 11-2 is out of range there are two four possible causes of failure.

1. The screws retaining the IR photo detector to the absorption bench have become loose. Carefully tighten the screws, hand-tight and note whether, after the analyzer has come up to operating temperature, whether the **PHT DRIVE** voltage has returned to an acceptable level.

2. The two large transistor-type devices mounted to the side of the Absorption Bench have come loose from the bench. Tighten the retaining screws and note whether there is an improvement in the **PHT DRIVE** voltage.
3. The photo-detector has failed. Contact the factory for instructions.
4. The sync demodulator circuit board has failed. Contact the factor for instructions.

10.4.2. Excessive Noise

Noise is continuously monitored in the TEST functions as the **STABIL** reading and only becomes meaningful after sampling a constant gas concentration for at least 10 minutes. Compare the current **STABIL** reading with that recorded at the time of manufacture (included in the GFC 7000T *Final Test and Validation Data Sheet*-p/n 04271 shipped with the unit from Teledyne Instruments).

1. The most common cause of excessive noise is leaks. Leak check and flow check the instrument described in Section 9.3.
2. Detector failure – caused by failure of the hermetic seal or over-temperature due to poor heat sinking of the detector can to the optical bench. In addition to increased noise due to poor signal-to-noise ratio, another indicator of detector failure is a drop in the signal levels of the **CO₂ MEASURE** signal and **CO₂ REFERENCE** signal.
3. Sync/Demod Board failure. There are many delicate, high impedance parts on this board. Check the **CO₂ MEAS** and **CO₂ REF** Test Functions via the Front Panel Display.
4. The detector cooler control circuit can fail for reasons similar to the detector itself failing. Symptoms would be a change in **MR RATIO** Test Function when zero air is being sampled.

Also check the SIGNAL I/O parameter **PHT DRIVE**. After warm-up, and at 25°C ambient, if PHT DRIVE < 4800 mV, the cooler is working properly. If PHT DRIVE is > 4800 mV there is a malfunction.

5. The +5 and ±15 VDC voltages in the GFC 7000T are provided by switching power supplies. Switch mode supplies create DC outputs by switching the input AC waveform at high frequencies. As the components in the switcher age and degrade, the main problem observed is increased noise on the DC outputs. If a noisy switcher power supply is suspected, attach an oscilloscope to the DC output test points located on the top right hand edge of the Relay board. Look for short period spikes > 100 mV p-p on the DC output.



10.5. Subsystem Checkout

The preceding section of this manual discussed a variety of methods for identifying possible sources of failures or performance problems within the analyzer. In most cases this included a list of possible causes. This describes how to determine individually determine if a certain component or subsystem is actually the cause of the problem being investigated.

10.5.1. AC Mains Configuration

The analyzer is correctly configured for the AC mains voltage in use if:

1. The GFC wheel motor is spinning. LED's D1 & D2 (located on the synch/demod PCA) should be flashing.
2. If incorrect power is suspected, check that the correct voltage and frequency is present at the line input on the rear panel.
 - If the unit is set for 230 VAC and is plugged into 115VAC, or 100VAC the heaters will not come up to temperature.
 - If the unit is set for 115 or 100 VAC and is plugged into a 230 VAC circuit, the circuit breaker built into the ON/OFF Switch on the Front Panel will trip to the OFF position immediately after power is switched on.

10.5.2. DC Power Supply

If you have determined that the analyzer's AC mains power is working, but the unit is still not operating properly, there may be a problem with one of the instrument's switching power supplies. The supplies can have two faults, namely no DC output, and noisy output.

To assist tracing DC Power Supply problems, the wiring used to connect the various printed circuit assemblies and DC Powered components and the associated test points on the relay board follow a standard color-coding scheme as defined in the following table.

Table 10-6: DC Power Test Point and Wiring Color Codes

NAME	TEST POINT#	TP AND WIRE COLOR
Dgnd	1	Black
+5V	2	Red
Agnd	3	Green
+15V	4	Blue
-15V	5	Yellow
+12R	6	Purple
+12V	7	Orange

A voltmeter should be used to verify that the DC voltages are correct per the values in the table below, and an oscilloscope, in AC mode, with band limiting turned on, can be used to evaluate if the supplies are producing excessive noise (> 100 mV p-p).

Table 10-7: DC Power Supply Acceptable Levels

POWER SUPPLY ASSY	VOLTAGE	CHECK RELAY BOARD TEST POINTS				MIN V	MAX V
		FROM TEST POINT		TO TEST POINT			
		NAME	#	NAME	#		
PS1	+5	Dgnd	1	+5	2	4.8	5.25
PS1	+15	Agnd	3	+15	4	13.5	16V
PS1	-15	Agnd	3	-15V	5	-14V	-16V
PS1	Agnd	Agnd	3	Dgnd	1	-0.05	0.05
PS1	Chassis	Dgnd	1	Chassis	N/A	-0.05	0.05
PS2	+12	+12V Ret	6	+12V	7	11.75	12.5
PS2	Dgnd	+12V Ret	6	Dgnd	1	-0.05	0.05

10.5.3. I²C Bus

Operation of the I²C bus can be verified by observing the behavior of D1 on the Relay PCA & D2 on the Valve Driver PCA . Assuming that the DC power supplies are operating properly, the I²C bus is operating properly if: D1 on the relay PCA and D2 of the Valve Driver PCA are flashing

There is a problem with the I²C bus if both D1 on the relay PCA and D2 of the Valve Driver PCA are ON/OFF constantly (steady lit or steady off)

10.5.4. Touchscreen Interface

Verify the functioning of the touchscreen by observing the display when pressing a touchscreen control button. Assuming that there are no wiring problems and that the DC power supplies are operating properly, if pressing a control button on the display does not change the display, any of the following may be the problem:

- The touchscreen controller may be malfunctioning.
- The internal USB bus may be malfunctioning.

You can verify this failure by logging on to the instrument using APICOM or a terminal program to any of the communications ports. If the analyzer responds to remote commands and the display changes accordingly, the touchscreen interface may be faulty.

10.5.5. LCD Display Module

Verify the functioning of the front panel display by observing it when power is applied to the instrument. Assuming that there are no wiring problems and that the DC power supplies are operating properly, the display screen should light and show the splash screen with logo and other indications of its state as the CPU goes through its initialization process.

10.5.6. Relay Board

The relay board PCA (04135) can be most easily checked by observing the condition of the its status LEDs on the relay board, as described in Section 10.1.4.3, and the associated output when toggled on and off through signal I/O function in the diagnostic menu, See Section 10.1.3.

1. If the front panel display responds to button presses and D1 on the relay board is not flashing, then either the I²C connection between the motherboard and the relay board is bad, or the relay board itself is bad.
2. If D1 on the relay board is flashing and the status indicator for the output in question (heater power, valve drive, etc.) toggles properly using the signal I/O function, then the associated control device on the relay board is bad. Several of the control devices are in sockets and can be easily replaced. The table below lists the control device associated with a particular function:

Table 10-8: Relay Board Control Devices

FUNCTION	CONTROL DEVICE	IN SOCKET
Wheel Heater	K1	Yes
Bench Heater	K2	Yes
Spare AC Control	K3	Yes
IZS Valves	U4	Yes
IR Source Drive	U5	No

The IR source drive output can be verified by measuring the voltage at J16 with the IR source disconnected. It should be 11.5± 0.5 VDC.

10.5.7. Sensor Assembly

10.5.7.1. Sync/Demodulator Assembly

To verify that the Sync/Demodulator Assembly is working follow the procedure below:

1. Verify that D1 and D2 are flashing (they flash at different rates, see Table 11-3).
 - If not check the opto pickup assembly, Section 10.5.7.2 and the GFC wheel drive, Section 11.5.6.3.
 - If the wheel drive and opto pickup are working properly then verify that there is 2.4 ±0.1 VAC and 2.5 ±0.15 VDC between digital ground and TP 5 on the sync demod board. If not then check the wiring between the sync/demod and opto pickup assembly (see interconnect drawing 04216). If good then the sync/demod board is bad.
2. Verify that the IR source is operating, Section 10.5.7.4.
3. With the analyzer connected to zero air, measure between TP11 (measure) and analog ground, and TP12 (reference) and analog ground.
 - If they are similar to values recorded on the factory data sheet then there is likely a problem with the wiring or the A/D converter.

- If they are not then either the sync demodulator board or the IR-photodetector are bad. See Section 10.4.1.4 for problems with the IR-photodetector TEC drive.

10.5.7.2. Opto Pickup Assembly

Operation of the opto pickup PCA (04088) can be verified with a voltmeter. Measure the AC and DC voltage between digital ground on the relay board, or touchscreen and TP1 and TP2 on the sync pickup PCA. For a working board, with the GFC motor spinning, they should read 2.4 ± 0.1 VAC and 2.5 ± 0.15 VDC.

Further confirmation that the pickups and motor are operating properly can be obtained by measuring the frequency at TP1 and TP2 using a frequency counter, a digital volt meter with a frequency counter, or an oscilloscope per the table below.

Table 10-9: Opto Pickup Board Nominal Output Frequencies

AC MAINS FREQ.	NOMINAL MEASURED FREQUENCY	
	TP1	TP2
50 Hz	25	300
60 Hz	30	360

10.5.7.3. GFC Wheel Drive

If the D1 and D2 on the sync demodulator board are not flashing then:

1. Check for power to the motor by measuring between pins 1 and 3 on the connector feeding the motor. For instruments configured for 120 or 220-240VAC there should be approximately 88 VAC for instruments configured for 100VAC, it should be the voltage of the AC mains, approximately 100VAC.
2. Verify that the frequency select jumper, JP4, is properly set on the Relay Board. For 50 Hz operation it should be installed. For 60 Hz operation may either be missing or installed in a vertical orientation.
3. If there is power to the motor and the frequency select jumper is properly set then the motor is likely bad. See Section 10.6.1 for instructions on removing and replacing the GFC assembly that the motor is bolted to.

10.5.7.4. IR Source

The IR source can be checked using the following procedure:

1. Disconnect the source and check its resistance when cold. When new, the source should have a cold resistance of more than 1.5 Ohms but less than 3.5 Ohms. If not, then the source is bad.
2. With the source disconnected, energize the analyzer and wait for it to start operating. Measure the drive Voltage between pins 1 and 2 on the jack that the source is normally connected to; it should be 11.5 ± 0.25 VDC. If not, then there is a problem with either the wiring, the Relay Board, or the +12V power supply.

3. If the drive voltage is correct in step 2, then remove the source from the heat sink assembly (2 screws on top) and connect to its mating connector. Observe the light being emitted from the source. It should be centered at the bottom of the U-shaped element. If there is either no emission or a badly centered emission then the source is bad.

10.5.8. Motherboard

10.5.8.1. A/D Functions

The simplest method to check the operation of the A-to-D converter on the motherboard is to use the Signal I/O function under the DIAG menu to check the two A/D reference voltages and input signals that can be easily measured with a voltmeter.

1. Use the Signal I/O function (See Section 10.1.3 and Appendix A) to view the value of **REF_4096_MV** and **REF_GND**. If both are within 3 mV of nominal (4096 and 0), and are stable, ± 0.5 mV then the basic A/D is functioning properly. If not then the motherboard is bad.
2. Choose a parameter in the Signal I/O function such as **SAMPLE_PRESSURE**, **SAMPLE_FLOW**, **CO₂_MEASURE** or **CO₂_REFERENCE**. Compare these voltages at their origin (see interconnect drawing 04215 and interconnect list 04216) with the voltage displayed through the signal I/O function. If the wiring is intact but there is a large difference between the measured and displayed voltage (± 10 mV) then the motherboard is bad.

10.5.8.2. Analog Outputs: Voltage

To verify that the analog outputs are working properly, connect a voltmeter to the output in question and perform an analog output step test as described in Section 6.9.3.

For each of the steps, taking into account any offset that may have been programmed into channel (See Section 6.9.4), the output should be within 1% of the nominal value listed in the table below except for the 0% step, which should be within 2 to 3 mV. If one or more of the steps fails to be within this range then it is likely that there has been a failure of the either or both of the DACs and their associated circuitry on the motherboard.

Table 10-10: Analog Output Test Function - Nominal Values Voltage Outputs

		FULL SCALE OUTPUT VOLTAGE			
		100MV	1V	5V	10V
STEP	%	NOMINAL OUTPUT VOLTAGE			
1	0	0	0	0	0
2	20	20 mV	0.2	1	2
3	40	40 mV	0.4	2	4
4	60	60 mV	0.6	3	6
5	80	80 mV	0.8	4	8
6	100	100 mV	1.0	5	10

10.5.8.3. Analog Outputs: Current Loop

To verify that the analog outputs with the optional current mode output are working properly, connect a 250 ohm resistor across the outputs and use a voltmeter to measure the output as described in Section 6.9.4.2 and then perform an analog output step test as described in Section 6.9.3.

For each step the output should be within 1% of the nominal value listed in the table below.

Table 10-11: Analog Output Test Function - Nominal Values Current Outputs

		OUTPUT RANGE			
		2 -20		4 -20	
		NOMINAL OUTPUT VALUES			
STEP	%	CURRENT	V(250 OHMS)	CURRENT	V(250 OHMS)
1	0	2 mA	0.5V	4	1
2	20	5.6	1.4	7.2	1.8
3	40	9.2	2.3	10.4	2.6
4	60	12.8	3.2	13.6	3.4
5	80	16.4	4.1	16.8	4.2
6	100	20	5	20	5

10.5.8.4. Status Outputs

The procedure below can be used to test the Status outputs:

1. Connect a jumper between the “D” pin and the “▽” pin on the status output connector.
2. Connect a 1000 ohm resistor between the “+” pin and the pin for the status output that is being tested.
3. Connect a voltmeter between the “▽” pin and the pin of the output being tested (see table below).

Under the **DIAG** → **SIGNAL I/O** menu (See Section 10.1.3), scroll through the inputs and outputs until you get to the output in question. Alternately turn on and off the output noting the voltage on the voltmeter, it should vary between 0 volts for ON and 5 volts for OFF.

Table 10-12: Status Outputs Check

PIN (LEFT TO RIGHT)	STATUS
1	SYSTEM OK
2	CONC VALID
3	HIGH RANGE
4	ZERO CAL
5	SPAN CAL
6	DIAG MODE
7	ALRM1
8	ALRM2

10.5.8.5. Control Inputs – Remote Zero, Span

The control input bits can be tested by the following procedure:

1. Connect a jumper from the +5 pin on the Status connector to the x5V on the Control In connector.
2. Connect a second jumper from the ‘-’ pin on the Status connector to the A pin on the Control In connector. The instrument should switch from **SAMPLE** mode to **ZERO CAL R** mode.
3. Connect a second jumper from the ‘-’ pin on the Status connector to the B pin on the Control In connector. The instrument should switch from **SAMPLE** mode to **SPAN CAL R** mode.
4. In each case, the GFC 7000T should return to **SAMPLE** mode when the jumper is removed.

10.5.9. CPU

There are two major types of failures associated with the CPU board: complete failure and a failure associated with the Disk on Module (DOM). If either of these failures occur, contact the factory.

For complete failures, assuming that the power supplies are operating properly and the wiring is intact, the CPU is faulty if on power-on, the watchdog LED on the motherboard is not flashing.

In some rare circumstances, this failure may be caused by a bad IC on the motherboard, specifically U57, the large, 44-pin device on the lower right hand side of the board. If this is true, removing U57 from its socket will allow the instrument to start up but the measurements will be invalid.

If the analyzer stops during initialization (the front panel display shows a fault or warning message), it is likely that the DOM, the firmware or the configuration and data files have been corrupted.

10.5.10. RS-232 Communications

10.5.10.1. General RS-232 Troubleshooting

Teledyne Instruments analyzers use the RS-232 communications protocol to allow the instrument to be connected to a variety of computer-based equipment. RS-232 has been used for many years and as equipment has become more advanced, connections between various types of hardware have become increasingly difficult. Generally, every manufacturer observes the signal and timing requirements of the protocol very carefully.

Problems with RS-232 connections usually center around 4 general areas:

1. Incorrect cabling and connectors. See Section 6.11.2 for connector and pin-out information.
2. The BAUD rate and protocol are incorrectly configured. See Section 6.10.7.
3. If a modem is being used, additional configuration and wiring rules must be observed. See Section 6.13.2.6
4. Incorrect setting of the DTE – DCE Switch is set correctly. See Section 6.10.5
5. Verify that cable (03596) that connects the serial COM ports of the CPU to J12 of the motherboard is properly seated

10.5.10.2. Troubleshooting Analyzer/Modem or Terminal Operation

These are the general steps for troubleshooting problems with a modem connected to a Teledyne Instruments analyzer.

1. Check cables for proper connection to the modem, terminal or computer.
2. Check to make sure the DTE-DCE is in the correct position as described in Section 6.10.5.
3. Check to make sure the set up command is correct (See Section 6.13.2.7)
4. Verify that the Ready to Send (RTS) signal is at logic high. The GFC 7000T sets pin 7 (RTS) to greater than 3 volts to enable modem transmission.
5. Make sure the BAUD rate, word length, and stop bit settings between modem and analyzer match, See Section 6.10.7.
6. Use the RS-232 test function to send "w" characters to the modem, terminal or computer; See Section 6.10.8.
7. Get your terminal, modem or computer to transmit data to the analyzer (holding down the space bar is one way); the green LED should flicker as the instrument is receiving data.
8. Make sure that the communications software or terminal emulation software is functioning properly.

Further help with serial communications is available in a separate manual "RS-232 Programming Notes" Teledyne Instruments part number 013500000.

10.6. Repair Procedures

This contains procedures that might need to be performed on rare occasions when a major component of the analyzer requires repair or replacement.

10.6.1. Removing/Replacing the GFC Wheel

When removing or replacing the GFC Wheel it is important to perform the disassembly in the following order to avoid damaging the components:

1. Turn off the analyzer.
2. Remove the top cover as described in “Getting Started” Section 3.1.
3. Open the instrument’s hinged front panel.
4. Locate the GFC wheel/motor assembly (see Figure 3-3).
5. Unplug the following electronic components:
 - The GFC wheel housing temperature sensor;
 - GFC wheel heater
 - GFC wheel motor power supply
 - IR source
6. Unscrew the purge gas line hex nut and remove the 1/8 inch FEP purge gas line.

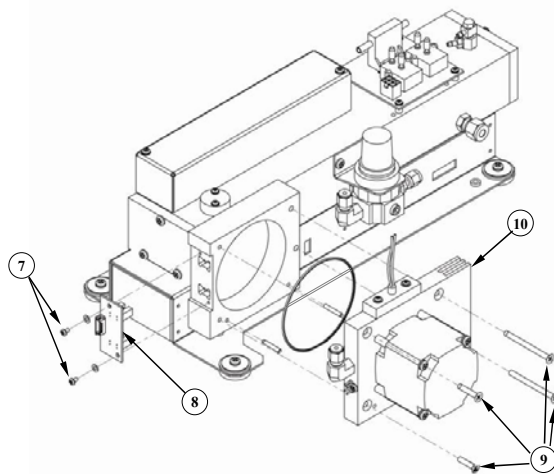

Figure 10-9: Opening the GFC Wheel Housing

7. Remove the two (2) screws holding the opto-pickup printed circuit assembly to the GFC wheel housing.
8. Carefully remove the opto-pickup printed circuit assembly.



9. Remove the four (4) screws holding the GFC wheel motor/heat sink assembly to the GFC wheel housing.
10. Carefully remove the GFC wheel motor/heat sink assembly from the GFC wheel housing.
11. Remove the one (1) screw fastening the GFC wheel/mask assembly to the GFC motor hub.

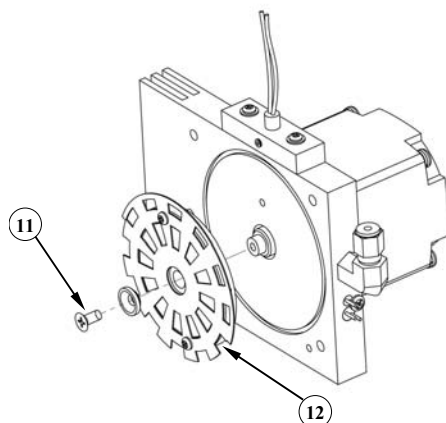

Figure 10-10: Removing the GFC Wheel

12. Remove the GFC wheel/mask assembly.
13. Follow the previous steps in reverse order to put the GFC wheel/motor assembly back together.

10.6.2. Disk-On-Module Replacement Procedure

NOTE

Servicing of circuit components requires electrostatic discharge protection, i.e. ESD grounding straps, mats and containers. Failure to use ESD protection when working with electronic assemblies will void the instrument warranty. Refer to Section 11 for more information on preventing ESD damage.

Replacing the Disk-on-Module (DOM) will cause loss of all DAS data; it may also cause loss of some instrument configuration parameters unless the replacement DOM carries the exact same firmware version. Whenever changing the version of installed software, the memory must be reset. Failure to ensure that memory is reset can cause the analyzer to malfunction, and invalidate measurements. After the memory is reset, the A/D converter must be re-calibrated, and all information collected in Step 1 below must be re-entered before the instrument will function correctly. Also, zero and span calibration should be performed.

1. Document all analyzer parameters that may have been changed, such as range, auto-cal, analog output, serial port and other settings before replacing the DOM.
2. Turn off power to the instrument, fold down the rear panel by loosening the mounting screws.
3. When looking at the electronic circuits from the back of the analyzer, locate the Disk-on-Module in the right-most socket of the CPU board.
4. The DOM should carry a label with firmware revision, date and initials of the programmer.

5. Remove the nylon standoff clip that mounts the DOM over the CPU board, and lift the DOM off the CPU. Do not bend the connector pins.
6. Install the new Disk-on-Module, making sure the notch at the end of the chip matches the notch in the socket.
7. It may be necessary to straighten the pins somewhat to fit them into the socket. Press the chip all the way in.
8. Close the rear panel and turn on power to the machine.

This page intentionally left blank.

11. A PRIMER ON ELECTRO-STATIC DISCHARGE

Teledyne Instruments considers the prevention of damage caused by the discharge of static electricity to be extremely important part of making sure that your analyzer continues to provide reliable service for a long time. This section describes how static electricity occurs, why it is so dangerous to electronic components and assemblies as well as how to prevent that damage from occurring.

11.1. How Static Charges are Created

Modern electronic devices such as the types used in the various electronic assemblies of your analyzer, are very small, require very little power and operate very quickly. Unfortunately, the same characteristics that allow them to do these things also make them very susceptible to damage from the discharge of static electricity. Controlling electrostatic discharge begins with understanding how electro-static charges occur in the first place.

Static electricity is the result of something called triboelectric charging which happens whenever the atoms of the surface layers of two materials rub against each other. As the atoms of the two surfaces move together and separate, some electrons from one surface are retained by the other.

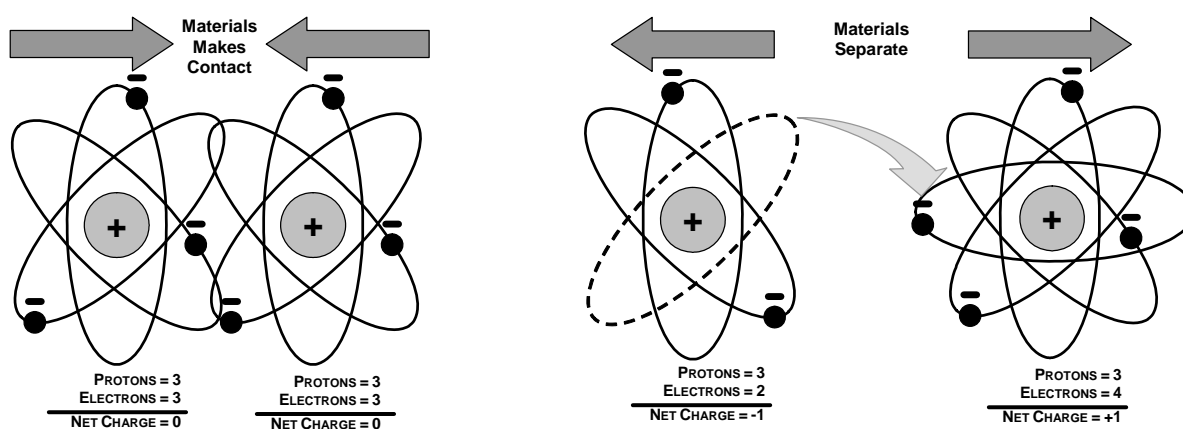

Figure 11-1: Triboelectric Charging

If one of the surfaces is a poor conductor or even a good conductor that is not grounded, the resulting positive or negative charge cannot bleed off and becomes trapped in place, or static. The most common example of triboelectric charging happens when someone wearing leather or rubber soled shoes walks across a nylon carpet or linoleum tiled floor. With each step, electrons change places and the resulting electro-static charge builds up, quickly reaching significant levels. Pushing an epoxy printed circuit board across a workbench, using a plastic handled screwdriver or even the constant jostling of StyrofoamTM pellets during shipment can also build hefty static charges

Table 11-1: Static Generation Voltages for Typical Activities

MEANS OF GENERATION	65-90% RH	10-25% RH
Walking across nylon carpet	1,500V	35,000V
Walking across vinyl tile	250V	12,000V
Worker at bench	100V	6,000V

Poly bag picked up from bench	1,200V	20,000V
Moving around in a chair padded with urethane foam	1,500V	18,000V

11.2. How Electro-Static Charges Cause Damage

Damage to components occurs when these static charges come into contact with an electronic device. Current flows as the charge moves along the conductive circuitry of the device and the typically very high voltage levels of the charge overheat the delicate traces of the integrated circuits, melting them or even vaporizing parts of them. When examined by microscope the damage caused by electro-static discharge looks a lot like tiny bomb craters littered across the landscape of the component's circuitry.

A quick comparison of the values in Table 12-1 with the those shown in the Table 12-2, listing device susceptibility levels, shows why *Semiconductor Reliability News* estimates that approximately 60% of device failures are the result of damage due to electro-static discharge.

Table 11-2: Sensitivity of Electronic Devices to Damage by ESD

DEVICE	DAMAGE SUSCEPTIBILITY VOLTAGE RANGE	
	DAMAGE BEGINS OCCURRING AT	CATASTROPHIC DAMAGE AT
MOSFET	10	100
VMOS	30	1800
NMOS	60	100
GaAsFET	60	2000
EPROM	100	100
JFET	140	7000
SAW	150	500
Op-AMP	190	2500
CMOS	200	3000
Schottky Diodes	300	2500
Film Resistors	300	3000
This Film Resistors	300	7000
ECL	500	500
SCR	500	1000
Schottky TTL	500	2500

Potentially damaging electro-static discharges can occur:

- Any time a charged surface (including the human body) discharges to a device. Even simple contact of a finger to the leads of a sensitive device or assembly can allow enough discharge to cause damage. A similar discharge can occur from a charged conductive object, such as a metallic tool or fixture.
- When static charges accumulated on a sensitive device discharges from the device to another surface such as packaging materials, work surfaces, machine surfaces or other device. In some cases, charged device discharges can be the most destructive.

A typical example of this is the simple act of installing an electronic assembly into the connector or wiring harness of the equipment in which it is to function. If the assembly is carrying a static charge, as it is connected to ground a discharge will occur.

- Whenever a sensitive device is moved into the field of an existing electro-static field, a charge may be induced on the device in effect discharging the field onto the device. If the device is then momentarily grounded while within the electrostatic field or removed from the region of the electrostatic field and grounded somewhere else, a second discharge will occur as the charge is transferred from the device to ground.

11.3. Common Myths About ESD Damage

- **I didn't feel a shock so there was no electro-static discharge:** The human nervous system isn't able to feel a static discharge of less than 3500 volts. Most devices are damaged by discharge levels much lower than that.
- **I didn't touch it so there was no electro-static discharge:** Electro-static charges are fields whose lines of force can extend several inches or sometimes even feet away from the surface bearing the charge.
- **It still works so there was no damage:** Sometimes the damage caused by electro-static discharge can completely sever a circuit trace causing the device to fail immediately. More likely, the trace will be only partially occluded by the damage causing degraded performance of the device or worse, weakening the trace. This weakened circuit may seem to function fine for a short time, but even the very low voltage and current levels of the device's normal operating levels will eat away at the defect over time causing the device to fail well before its designed lifetime is reached.

These latent failures are often the most costly since the failure of the equipment in which the damaged device is installed causes down time, lost data, lost productivity, as well as possible failure and damage to other pieces of equipment or property.

- **Static Charges can't build up on a conductive surface:** There are two errors in this statement.

Conductive devices can build static charges if they are not grounded. The charge will be equalized across the entire device, but without access to earth ground, they are still trapped and can still build to high enough levels to cause damage when they are discharged.

A charge can be induced onto the conductive surface and/or discharge triggered in the presence of a charged field such as a large static charge clinging to the surface of a nylon jacket of someone walking up to a workbench.

- **As long as my analyzer is properly installed, it is safe from damage caused by static discharges:** It is true that when properly installed the chassis ground of your analyzer is tied to earth ground and its electronic components are prevented from building static electric charges themselves. This does not prevent discharges from static fields built up on other things, like you and your clothing, from discharging through the instrument and damaging it.

11.4. Basic Principles of Static Control

It is impossible to stop the creation of instantaneous static electric charges. It is not, however difficult to prevent those charges from building to dangerous levels or prevent damage due to electro-static discharge from occurring.

11.4.1. General Rules

Only handle or work on all electronic assemblies at a properly set up ESD station. Setting up an ESD safe workstation need not be complicated. A protective mat properly tied to ground and a wrist strap are all that is needed to create a basic anti-ESD workstation (see figure 12-2).

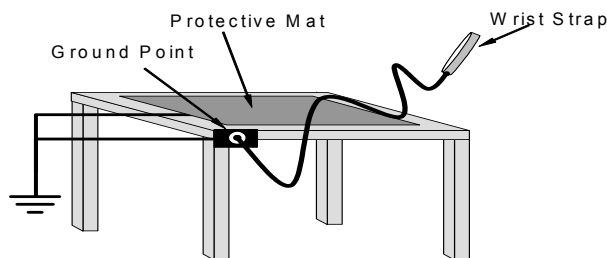

Figure 11-2: Basic anti-ESD Work Station

For technicians that work in the field, special lightweight and portable anti-ESD kits are available from most suppliers of ESD protection gear. These include everything needed to create a temporary anti-ESD work area anywhere.

- **Always wear an Anti-ESD wrist strap when working on the electronic assemblies of your analyzer.** An anti-ESD wrist strap keeps the person wearing it at or near the same potential as other grounded objects in the work area and allows static charges to dissipate before they can build to dangerous levels. Anti-ESD wrist straps terminated with alligator clips are available for use in work areas where there is no available grounded plug.

Also, anti-ESD wrist straps include a current limiting resistor (usually around one meg-ohm) that protects you should you accidentally short yourself to the instrument's power supply.

- **Simply touching a grounded piece of metal is insufficient.** While this may temporarily bleed off static charges present at the time, once you stop touching the grounded metal new static charges will immediately begin to re-build. In some conditions, a charge large enough to damage a component can rebuild in just a few seconds.
- **Always store sensitive components and assemblies in anti-ESD storage bags or bins:** Even when you are not working on them, store all devices and assemblies in a closed anti-Static bag or bin. This will prevent induced charges from building up on the device or assembly and nearby static fields from discharging through it.
- **Use metallic anti-ESD bags for storing and shipping ESD sensitive components and assemblies rather than pink-poly bags.** The famous, "pink-poly" bags are made of a plastic that is impregnated with a liquid (similar to liquid laundry detergent) which very slowly sweats onto the surface of the plastic creating a slightly conductive layer over the surface of the bag.

While this layer may equalizes any charges that occur across the whole bag, it does not prevent the build up of static charges. If laying on a conductive, grounded surface, these bags will allow charges to bleed away but the very charges that build up on the surface of the bag itself can be transferred through the bag by induction onto the circuits of your ESD sensitive device. Also, the liquid impregnating the plastic is eventually used up after which the bag is as useless for preventing damage from ESD as any ordinary plastic bag.

Anti-Static bags made of plastic impregnated with metal (usually silvery in color) provide all of the charge equalizing abilities of the pink-poly bags but also, when properly sealed, create a Faraday cage that completely isolates the contents from discharges and the inductive transfer of static charges.

Storage bins made of plastic impregnated with carbon (usually black in color) are also excellent at dissipating static charges and isolating their contents from field effects and discharges.

- **Never use ordinary plastic adhesive tape near an ESD sensitive device or to close an anti-ESD bag.** The act of pulling a piece of standard plastic adhesive tape, such as Scotch[®] tape, from its roll will generate a static charge of several thousand or even tens of thousands of volts on the tape itself and an associated field effect that can discharge through or be induced upon items up to a foot away.

11.4.2. Basic anti-ESD Procedures for Analyzer Repair and Maintenance

11.4.2.1. Working at the Instrument Rack

When working on the analyzer while it is in the instrument rack and plugged into a properly grounded power supply.

1. Attach your anti-ESD wrist strap to ground before doing anything else.
 - Use a wrist strap terminated with an alligator clip and attach it to a bare metal portion of the instrument chassis. This will safely connect you to the same ground level to which the instrument and all of its components are connected.
2. Pause for a second or two to allow any static charges to bleed away.
3. Open the casing of the analyzer and begin work. Up to this point, the closed metal casing of your analyzer has isolated the components and assemblies inside from any conducted or induced static charges.
4. If you must remove a component from the instrument, do not lay it down on a non-ESD preventative surface where static charges may lie in wait.
5. Only disconnect your wrist strap after you have finished work and closed the case of the analyzer.

11.4.2.2. Working at an Anti-ESD Work Bench.

When working on an instrument of an electronic assembly while it is resting on an anti-ESD work bench:

1. Plug your anti-ESD wrist strap into the grounded receptacle of the work station before touching any items on the work station and while standing at least a foot or so away. This will allow any charges you are carrying to bleed away through the ground connection of the workstation and prevent discharges due to field effects and induction from occurring.
2. Pause for a second or two to allow any static charges to bleed away.
3. Only open any anti-ESD storage bins or bags containing sensitive devices or assemblies after you have plugged your wrist strap into the workstation.
 - Lay the bag or bin on the workbench surface.
 - Before opening the container, wait several seconds for any static charges on the outside surface of the container to be bled away by the workstation's grounded protective mat.
4. Do not pick up tools that may be carrying static charges while also touching or holding an ESD Sensitive Device.
 - Only lay tools or ESD-sensitive devices and assemblies on the conductive surface of your workstation. Never lay them down on any non-ESD preventative surface.
5. Place any static sensitive devices or assemblies in anti-static storage bags or bins and close the bag or bin before unplugging your wrist strap.
6. Disconnecting your wrist strap is always the last action taken before leaving the workbench.

11.4.2.3. Transferring Components from Rack to Bench and Back

When transferring a sensitive device from an installed Teledyne Instruments analyzer to an Anti-ESD workbench or back:

1. Follow the instructions listed above for working at the instrument rack and workstation.
2. Never carry the component or assembly without placing it in an anti-ESD bag or bin.
3. Before using the bag or container allow any surface charges on it to dissipate:
 - If you are at the instrument rack, hold the bag in one hand while your wrist strap is connected to a ground point.
 - If you are at an anti-ESD workbench, lay the container down on the conductive work surface.
 - In either case wait several seconds.
4. Place the item in the container.
5. Seal the container. If using a bag, fold the end over and fastening it with anti-ESD tape.
 - Folding the open end over isolates the component(s) inside from the effects of static fields.
 - Leaving the bag open or simply stapling it shut without folding it closed prevents the bag from forming a complete protective envelope around the device.
6. Once you have arrived at your destination, allow any surface charges that may have built up on the bag or bin during travel to dissipate:
 - Connect your wrist strap to ground.
 - If you are at the instrument rack, hold the bag in one hand while your wrist strap is connected to a ground point.
 - If you are at a anti-ESD work bench, lay the container down on the conductive work surface
 - In either case wait several seconds
7. Open the container.

11.4.2.4. Opening Shipments from Teledyne Instruments Customer Service.

Packing materials such as bubble pack and Styrofoam pellets are extremely efficient generators of static electric charges. To prevent damage from ESD, Teledyne Instruments ships all electronic components and assemblies in properly sealed anti-ESD containers.

Static charges will build up on the outer surface of the anti-ESD container during shipping as the packing materials vibrate and rub against each other. To prevent these static charges from damaging the components or assemblies being shipped make sure that you always unpack shipments from Teledyne Instruments Customer Service by:

1. Opening the outer shipping box away from the anti-ESD work area.
2. Carry the still sealed ant-ESD bag, tube or bin to the anti-ESD work area.
3. Follow steps 6 and 7 of Section 11.4.2.3 above when opening the anti-ESD container at the work station.
4. Reserve the anti-ESD container or bag to use when packing electronic components or assemblies to be returned to Teledyne Instruments.

11.4.2.5. Packing Components for Return to Teledyne Instruments Customer Service.

Always pack electronic components and assemblies to be sent to Teledyne Instruments Customer Service in anti-ESD bins, tubes or bags.



WARNING

- **DO NOT** use pink-poly bags.
- **NEVER** allow any standard plastic packaging materials to touch the electronic component/assembly directly
 - This includes, but is not limited to, plastic bubble-pack, Styrofoam peanuts, open cell foam, closed cell foam, and adhesive tape
- **DO NOT** use standard adhesive tape as a sealer. Use **ONLY** anti-ESD tape

1. Never carry the component or assembly without placing it in an anti-ESD bag or bin.
2. Before using the bag or container allow any surface charges on it to dissipate:
 - If you are at the instrument rack, hold the bag in one hand while your wrist strap is connected to a ground point.
 - If you are at an anti-ESD workbench, lay the container down on the conductive work surface.
 - In either case wait several seconds.
3. Place the item in the container.
4. Seal the container. If using a bag, fold the end over and fastening it with anti-ESD tape.
 - Folding the open end over isolates the component(s) inside from the effects of static fields.
 - Leaving the bag open or simply stapling it shut without folding it closed prevents the bag from forming a complete protective envelope around the device.

NOTE

If you do not already have an adequate supply of anti-ESD bags or containers available, Teledyne Instruments' Customer Service department will supply them. Follow the instructions listed above for working at the instrument rack and workstation.

:

This page intentionally left blank.