

Use and Disclosure of Data

Information contained herein is classified as EAR99 under the U.S. Export Administration Regulations. Export, reexport or diversion contrary to U.S. law is prohibited.

Operation Manual
Model GFC 7002T/GFC 7002TU
N₂O Analyzer



P/N M07272
DATE 07/21/15

TELEDYNE ELECTRONIC TECHNOLOGIES
Analytical Instruments

16830 Chestnut Street
City of Industry, CA 91748
Telephone: (626) 934-1500
Fax: (626) 961-2538

Web: www.teledyne-ai.com

Copyright © 2015 Teledyne Analytical Instruments

All Rights Reserved. No part of this manual may be reproduced, transmitted, transcribed, stored in a retrieval system, or translated into any other language or computer language in whole or in part, in any form or by any means, whether it be electronic, mechanical, magnetic, optical, manual, or otherwise, without the prior written consent of Teledyne Analytical Instruments, 16830 Chestnut Street, City of Industry, CA 91748.

Warranty

This equipment is sold subject to the mutual agreement that it is warranted by us free from defects of material and of construction, and that our liability shall be limited to replacing or repairing at our factory (without charge, except for transportation), or at customer plant at our option, any material or construction in which defects become apparent within one year from the date of shipment, except in cases where quotations or acknowledgements provide for a shorter period. Components manufactured by others bear the warranty of their manufacturer. This warranty does not cover defects caused by wear, accident, misuse, neglect or repairs other than those performed by Teledyne or an authorized service center. We assume no liability for direct or indirect damages of any kind and the purchaser by the acceptance of the equipment will assume all liability for any damage which may result from its use or misuse.

We reserve the right to employ any suitable material in the manufacture of our apparatus, and to make any alterations in the dimensions, shape or weight of any parts, in so far as such alterations do not adversely affect our warranty.

Important Notice

This instrument provides measurement readings to its user, and serves as a tool by which valuable data can be gathered. The information provided by the instrument may assist the user in eliminating potential hazards caused by his process; however, it is essential that all personnel involved in the use of the instrument or its interface be properly trained in the process being measured, as well as all instrumentation related to it.

The safety of personnel is ultimately the responsibility of those who control process conditions. While this instrument may be able to provide early warning of imminent danger, it has no control over process conditions, and it can be misused. In particular, any alarm or control systems installed must be tested and understood, both as to how they operate and as to how they can be defeated. Any safeguards required such as locks, labels, or redundancy, must be provided by the user or specifically requested of Teledyne at the time the order is placed.

Therefore, the purchaser must be aware of the hazardous process conditions. The purchaser is responsible for the training of personnel, for providing hazard warning methods and instrumentation per the appropriate standards, and for ensuring that hazard warning devices and instrumentation are maintained and operated properly.

Teledyne Analytical Instruments, the manufacturer of this instrument, cannot accept responsibility for conditions beyond its knowledge and control. No statement expressed or implied by this document or any information disseminated by the manufacturer or its agents, is to be construed as a warranty of adequate safety control under the user's process conditions.

Trademarks

All trademarks, registered trademarks, brand names or product names appearing in this document are the property of their respective owners and are used herein for identification purposes only.

ABOUT THIS MANUAL

This manual describes operation, specifications, and maintenance for the Model GFC 7002T and GFC7002TU N₂O Analyzers.

In addition this manual contains important SAFETY messages for this instrument. It is strongly recommended that you read that operation manual in its entirety before operating the instrument.

ORGANIZATION

This manual is divided among three main parts and a collection of appendices at the end.

Part I contains introductory information that includes an overview of the analyzer, descriptions of the available options, specifications, installation and connection instructions, and the initial calibration and functional checks. The last two sections contain Frequently Asked Questions (FAQs) followed by a glossary, and a description of available options.

Part II comprises the operating instructions, which include basic, advanced and remote operation, calibration, diagnostics, testing, validating and verifying, and ends with specifics of calibrating for use in EPA monitoring.

Part III provides detailed technical information, such as theory of operation, maintenance, and troubleshooting and repair. It also contains a section that provides important information about electro-static discharge and avoiding its consequences.

The appendices at the end of this manual provide support information such as, version-specific software documentation, lists of spare parts and recommended stocking levels, and schematics.

CONVENTIONS USED

In addition to the safety symbols as presented in the *Important Safety Information* page, this manual provides *special notices* related to the safety and effective use of the analyzer and other pertinent information.

Special Notices appear as follows:

ATTENTION

COULD DAMAGE INSTRUMENT AND VOID WARRANTY

This special notice provides information to avoid damage to your instrument and possibly invalidate the warranty.

IMPORTANT

IMPACT ON READINGS OR DATA

Could either affect accuracy of instrument readings or cause loss of data.

Note

Pertinent information associated with the proper care, operation or maintenance of the analyzer or its parts.

This page intentionally left blank.

IMPORTANT SAFETY INFORMATION

Important safety messages are provided throughout this manual. Please read these messages carefully.

A safety message alerts you to potential hazards that could hurt you or others. Each safety message is associated with a safety alert symbol. These symbols are found in the manual and inside the instrument. The definition of these symbols is described below:



WARNING: Electrical Shock Hazard



HAZARD: Strong oxidizer



GENERAL WARNING/CAUTION: Read the accompanying message for specific information.



CAUTION: Hot Surface Warning



Technician Symbol: All operations marked with this symbol are to be performed by qualified maintenance personnel only.



DO NOT TOUCH: Touching some parts of the instrument without protection or proper tools could result in damage to the part(s) and/or the instrument.



Electrical Ground: This symbol inside the instrument marks the central safety grounding point for the instrument.

CAUTION - General Safety Hazard



This instrument should only be used for the purpose and in the manner described in this manual. If you use this instrument in a manner other than that for which it was intended, unpredictable behavior could ensue with possible hazardous consequences.

NEVER use any gas analyzer to sample combustible gas(es).

Note

 Technical Assistance regarding the use and maintenance of the GFC7002T or any other Teledyne product can be obtained by contacting Teledyne Customer Service Department:

Phone: 888-789-8168

Email: ask_tai@teledyne.com

or by accessing various service options on our website at

<http://www.teledyne-ai.com/>.

CONSIGNES DE SÉCURITÉ

Des consignes de sécurité importantes sont fournies tout au long du présent manuel dans le but d'éviter des blessures corporelles ou d'endommager les instruments. Veuillez lire attentivement ces consignes. Chaque consigne de sécurité est représentée par un pictogramme d'alerte de sécurité; ces pictogrammes se retrouvent dans ce manuel et à l'intérieur des instruments. Les symboles correspondent aux consignes suivantes :



AVERTISSEMENT : Risque de choc électrique



DANGER : Oxydant puissant



AVERTISSEMENT GÉNÉRAL / MISE EN GARDE : Lire la consigne complémentaire pour des renseignements spécifiques



MISE EN GARDE : Surface chaude



Ne pas toucher : Toucher à certaines parties de l'instrument sans protection ou sans les outils appropriés pourrait entraîner des dommages aux pièces ou à l'instrument.



Pictogramme « technicien » : Toutes les opérations portant ce symbole doivent être effectuées uniquement par du personnel de maintenance qualifié.



Mise à la terre : Ce symbole à l'intérieur de l'instrument détermine le point central de la mise à la terre sécuritaire de l'instrument.

MISE EN GARDE



Cet instrument doit être utilisé aux fins décrites et de la manière décrite dans ce manuel. Si vous utilisez cet instrument d'une autre manière que celle pour laquelle il a été prévu, l'instrument pourrait se comporter de façon imprévisible et entraîner des conséquences dangereuses.

NE JAMAIS utiliser un analyseur de gaz pour échantillonner des gaz combustibles!

TABLE OF CONTENTS

ABOUT THIS MANUAL	III
IMPORTANT SAFETY INFORMATION	V
CONSIGNES DE SÉCURITÉ	vi
TABLE OF CONTENTS	VII
LIST OF APPENDICES	xiii
List of Figures.....	xiii
List of Tables	xv
PART I GENERAL INFORMATION	1
1. INTRODUCTION, FEATURES AND OPTIONS	3
1.1. GFC7002T Family Overview	3
1.2. Features	4
1.3. GFC7002T/GFC7002TU Documentation	4
1.4. Options.....	4
2. SPECIFICATIONS AND APPROVALS	9
2.1. Specifications	9
2.2. EPA Equivalency Designation.....	10
2.3. Approvals and Certifications	10
2.3.1. Safety	10
2.3.2. EmC	10
2.3.3. Other Type Certifications	10
3. GETTING STARTED	11
3.1. Unpacking the GFC7002T/GFC7002TU Analyzer	11
3.1.1. Ventilation Clearance.....	12
3.2. Instrument Layout.....	13
3.2.1. Front Panel	13
3.2.2. Rear panel.....	17
3.2.3. GFC7002T/GFC7002TU Analyzer Layout	18
3.3. Connections and Setup.....	21
3.3.1. Electrical Connections	22
3.3.1.1. Connecting Power	22
3.3.1.2. Connecting Analog Inputs (Option)	22
3.3.1.3. Connecting Analog Outputs	23
3.3.1.4. Current Loop Analog Outputs (Option 41) Setup	24
3.3.1.5. Connecting the Status Outputs	26
3.3.1.6. Connecting the Control Inputs.....	27
3.3.1.7. Concentration Alarm Relay (Option 61) Standard Configuration	28
3.3.1.8. Concentration Alarm Relay (Option 61) Air Products Configuration	30
3.3.1.9. Connecting the Communication Interfaces	30
3.3.2. Pneumatic Connections	37
3.3.2.1. Pneumatic Connections for Basic Configuration	39
3.3.2.2. Pneumatic Layout for Basic configuration.....	40
3.3.2.3. Pneumatic Connections for Zero/ Span Valve Option	41
3.3.2.4. Pneumatic Layout for Zero/ Span Valve Option.....	44
3.3.2.5. Pneumatic Layout for Internal Zero/ Span Valve Option	45
3.3.2.6. Pneumatic Option Z/S Valve with Pressurized Zero and Span.....	46
3.3.2.7. Calibration Gases	46
3.4. Startup, Functional Checks, and Initial Calibration.....	48
3.4.1. Startup.....	48
3.4.2. Warning Messages	48
3.4.3. Functional Checks	50

3.4.4. Initial Calibration	51
3.4.4.1. Interferents for N ₂ O Measurements.....	51
3.4.4.2. Initial Calibration Procedure	53
3.4.4.3. O ₂ Sensor Calibration Procedure	58
3.4.4.4. CO ₂ Sensor Calibration Procedure.....	58
PART II OPERATING INSTRUCTIONS.....	59
4. OVERVIEW OF OPERATING MODES	61
4.1. Sample Mode	62
4.1.1. Test Functions	62
4.1.2. Warning Messages	65
4.2. Calibration Mode	66
4.3. Setup MODE	67
4.3.1. Password Security	67
4.3.2. Primary Setup Menu	67
4.3.3. Secondary Setup Menu (SETUP>MORE)	68
5. SETUP MENU	69
5.1. SETUP → CFG: Configuration Information	69
5.2. SETUP → ACAL: Automatic Calibration.....	70
5.3. SETUP →DAS: Internal Data Acquisition System	70
5.4. SETUP → RNGE: Analog Output Reporting Range Configuration.....	70
5.4.1. Analog Output Ranges for N ₂ O Concentration.....	70
5.4.2. Physical Range vs Analog Output Reporting Ranges	71
5.4.3. Reporting Range Modes: Single, Dual, Auto Ranges.....	72
5.4.3.1. SINGLE Range Mode (SNGL)	74
5.4.3.2. DUAL Range Mode (DUAL)	75
5.4.3.3. AUTO Range Mode (AUTO)	77
5.4.4. Range Units.....	79
5.4.5. Dilution Ratio (Option).....	80
5.5. SETUP → PASS: Password Protection.....	81
5.6. SETUP → CLK: Setting the Internal Time-of-Day Clock and Adjusting Speed	83
5.6.1.1. Setting the Internal Clock's Time and Day.....	83
5.6.1.2. Adjusting the Internal Clock's Speed	83
5.6.2. ID (Machine Identification).....	85
5.6.3. INET (Ethernet).....	85
5.6.4. COM1 and COM2 (Mode, Baud Rate and Test Port)	85
5.7. SETUP → VARS: Variables Setup and Definition.....	85
5.8. SETUP → Diag: Diagnostics Functions.....	87
5.8.1. Signal I/O.....	90
5.8.2. Analog Output.....	91
5.8.3. Analog I/O Configuration.....	91
5.8.3.1. Analog Output Calibration	96
5.8.3.2. Enabling or Disabling the AutoCal for an Individual Analog Output	96
5.8.3.3. Automatic Calibration of the Analog Outputs	97
5.8.3.4. Individual Calibration of the Analog Outputs.....	99
5.8.3.5. Manual Calibration of the Analog Outputs Configured for Voltage Ranges.....	100
5.8.3.6. Manual Adjustment of Current Loop Output Span and Offset	102
5.8.3.7. Turning an Analog Output Over-Range Feature ON/OFF	105
5.8.3.8. Adding a Recorder Offset to an Analog Output.....	106
5.8.3.9. AIN Calibration	107
5.8.3.10. Analog Inputs (XIN1...XIN8) Option Configuration.....	108
5.8.4. Electrical Test	108
5.8.5. Dark Calibration	109
5.8.6. Pressure Calibration	109
5.8.7. Flow Calibration	109
5.8.8. Test Chan Output	110

5.8.8.1. Selecting a Test Channel Function for Output A4	110
5.9. SETUP → MORE → ALRM (Option): Using the Gas Concentration Alarms	112
5.9.1. Setting the GFC7002T Concentration Alarm Limits	112
5.9.2. APR OPtion and Configuration	113
6. COMMUNICATIONS SETUP AND OPERATION	115
6.1. Data Terminal/Communication Equipment (DTE DCE)	115
6.2. Communication Modes, Baud Rate and Port Testing	115
6.2.1. Communication Modes	115
6.2.2. COM Port Baud Rate	117
6.2.3. Com Port Testing	118
6.3. RS-232	119
6.4. RS-485 (Option)	120
6.5. Ethernet	120
6.5.1. Configuring Ethernet Communication Manually (Static IP Address)	121
6.5.2. Configuring Ethernet Communication Using Dynamic Host Configuration Protocol (DHCP)	122
6.5.3. Changing the Analyzer's HOSTNAME	123
6.6. USB Port (Option) for Remote Access	125
7. DATA ACQUISITION SYSTEM (DAS) AND APICOM	127
7.1. DAS Structure	128
7.1.1. DAS Data Channels	128
7.1.2. Default DAS Channels	129
7.1.3. Viewing DAS Channels and Individual Records	132
7.1.4. Editing DAS Channels	133
7.1.4.1. Editing DAS Data Channel Names	134
7.1.5. Editing DAS Triggering Events	135
7.1.6. Editing DAS Parameters	136
7.1.7. Sample Period and Report Period	138
7.1.8. Number of Records	140
7.1.9. RS-232 Report Function	141
7.1.9.1. The Compact Report Feature	141
7.1.9.2. The Starting Date Feature	142
7.1.10. Disabling/Enabling Data Channels	142
7.1.11. HOLDOFF Feature	143
7.2. Remote DAS Configuration	144
7.2.1. DAS Configuration via APICOM	144
7.2.2. DAS Configuration Using Terminal Emulation Programs	146
8. REMOTE OPERATION	147
8.1. Computer Mode	147
8.1.1. Remote Control via APICOM	147
8.2. Interactive Mode	147
8.2.1. Remote Control via a Terminal Emulation Program	148
8.2.1.1. Help Commands in Interactive Mode	148
8.2.1.2. Command Syntax	148
8.2.1.3. Data Types	149
8.2.1.4. Status Reporting	150
8.2.1.5. General Message Format	150
8.3. Remote Access by Modem	150
8.4. Password Security for Serial Remote Communications	153
9. CALIBRATION PROCEDURES	155
9.1. Calibration Preparations	155
9.1.1. Required Equipment, Supplies, and Expendables	156
9.1.1.1. Zero Air	156
9.1.1.2. Span Gas	156
9.1.1.3. Calibration Gas Standards and Traceability	156
9.1.2. Data Recording Devices	157

9.2. Manual Calibration.....	157
9.2.1. Setup for Basic Calibration Checks and Calibration.....	157
9.2.2. Performing a Basic Manual Calibration Check.....	159
9.2.2.1. Setting the Expected Span Gas Concentration.....	160
9.2.2.2. Zero/Span Point Calibration Procedure.....	162
9.2.3. Setup for Calibration Using Valve Options.....	163
9.2.4. Manual Calibration Checks with Valve Options Installed.....	165
9.2.4.1. Setting the Expected Span Gas Concentration.....	166
9.2.4.2. Zero/Span Point Calibration Procedure.....	167
9.2.4.3. Use of Zero/Span Valve with Remote Contact Closure.....	169
9.3. Automatic Zero/Span Cal/Check (AutoCal).....	169
9.3.1. SETUP → ACAL: Programming and AUTO CAL Sequence.....	172
9.3.1.1. AutoCal with Auto or Dual Reporting Ranges Modes Selected.....	174
9.4. N ₂ O Calibration Quality.....	175
9.5. Calibration of the GFC7002T/GFC7002TU Electronic Subsystems.....	177
9.5.1. Dark Calibration Test.....	177
9.5.2. Pressure Calibration.....	178
9.5.3. Flow Calibration.....	179
9.6. Calibration of Optional Sensors.....	180
9.6.1. O ₂ Sensor Calibration.....	180
9.6.1.1. O ₂ Pneumatics Connections.....	180
9.6.1.2. Set O ₂ Span Gas Concentration.....	180
9.6.1.3. Activate O ₂ Sensor Stability Function.....	182
9.6.1.4. O ₂ ZERO/SPAN CALIBRATION.....	183
9.6.2. CO ₂ Sensor Calibration Procedure.....	184
9.6.2.1. CO ₂ Pneumatics Connections.....	184
9.6.2.2. Set CO ₂ Span Gas Concentration:.....	184
9.6.2.3. Activate CO ₂ Sensor Stability Function.....	186
9.6.2.4. CO ₂ Zero/Span Calibration.....	187
PART III TECHNICAL INFORMATION.....	189
10. MAINTENANCE SCHEDULE & PROCEDURES.....	191
10.1. Maintenance Schedule.....	191
10.2. Predicting Failures Using the Test Functions.....	195
10.3. Maintenance Procedures.....	196
10.3.1. Replacing the Sample Particulate Filter.....	196
10.3.2. Performing Leak Checks.....	197
10.3.2.1. Pressure Leak Check.....	197
10.3.3. Performing a Sample Flow Check.....	197
10.3.4. Cleaning the Optical Bench.....	198
10.3.5. Cleaning Exterior Surfaces of the GFC7002T/GFC7002TU.....	198
11. TROUBLESHOOTING AND SERVICE.....	199
11.1. General Troubleshooting.....	199
11.1.1. Fault Diagnosis with WARNING Messages.....	200
11.1.2. Fault Diagnosis with TEST Functions.....	203
11.1.3. the Diagnostic Signal I/O Function.....	205
11.1.4. Status LEDs.....	206
11.1.4.1. Motherboard Status Indicator (Watchdog).....	207
11.1.4.2. Sync Demodulator Status LEDs.....	208
11.1.4.3. Relay Board Status LEDs.....	209
11.2. Gas Flow Problems.....	211
11.2.1. GFC7002T/GFC7002TU Internal Gas Flow Diagrams.....	212
11.2.2. Typical Sample Gas Flow Problems.....	214
11.2.2.1. Flow is Zero.....	214
11.2.2.2. Low Flow.....	214
11.2.2.3. High Flow.....	215

11.2.2.4. Displayed Flow = "Warnings"	215
11.2.2.5. Actual Flow Does Not Match Displayed Flow	215
11.3. Calibration Problems	215
11.3.1. Miscalibrated	215
11.3.2. Non-Repeatable Zero and Span	216
11.3.3. Inability to Span – No SPAN Button (CAL S)	216
11.3.4. Inability to Zero – No ZERO Button (CAL Z)	216
11.4. Other Performance Problems	216
11.4.1. Temperature Problems	217
11.4.1.1. Box or Sample Temperature	217
11.4.1.2. Bench Temperature	217
11.4.1.3. GFC Wheel Temperature	218
11.4.1.4. IR Photo-Detector TEC Temperature	218
11.4.2. Excessive Noise	219
11.5. Subsystem Checkout	219
11.5.1. AC Mains Configuration	220
11.5.2. DC Power Supply	220
11.5.3. I ² C Bus	221
11.5.4. Touchscreen Interface	221
11.5.5. LCD Display Module	221
11.5.6. Relay Board	221
11.5.7. Sensor Assembly	222
11.5.7.1. Sync/Demodulator Assembly	222
11.5.7.2. Electrical Test	222
11.5.7.3. Opto Pickup Assembly	223
11.5.7.4. GFC Wheel Drive	223
11.5.7.5. IR Source	224
11.5.7.6. Pressure/Flow Sensor Assembly	224
11.5.8. Motherboard	225
11.5.8.1. A/D Functions	225
11.5.8.2. Test Channel / Analog Outputs Voltage	225
11.5.8.3. Analog Outputs: Current Loop	226
11.5.8.4. Status Outputs	227
11.5.8.5. Control Inputs – Remote Zero, Span	227
11.5.9. CPU	228
11.5.10. RS-232 Communications	228
11.5.10.1. General RS-232 Troubleshooting	228
11.5.10.2. Troubleshooting Analyzer/Modem or Terminal Operation	229
11.5.11. The Optional CO ₂ Sensor	229
11.6. Repair Procedures	230
11.6.1. Repairing Sample Flow Control Assembly	230
11.6.2. Removing/Replacing the GFC Wheel	231
11.6.3. Checking and Adjusting the Sync/Demodulator, Circuit Gain (N ₂ O MEAS)	233
11.6.3.1. Checking the Sync/Demodulator Circuit Gain	233
11.6.3.2. Adjusting the Sync/Demodulator, Circuit Gain	234
11.6.4. Disk-On-Module Replacement	235
11.7. Frequently Asked Questions	236
11.8. Technical Assistance	237
12. THEORY OF OPERATION	239
12.1. Measurement Method	239
12.1.1. Beer's Law	239
12.2. Measurement Fundamentals	240
12.2.1. Gas Filter Correlation	241
12.2.1.1. The GFC Wheel	241
12.2.1.2. The Measure Reference Ratio	242
12.2.1.3. Summary Interference Rejection	244

12.3. Flow Rate Control.....	245
12.3.1.1. Critical Flow Orifice.....	245
12.3.2. Particulate Filter.....	246
12.3.3. Pneumatic Sensors.....	247
12.3.3.1. Sample Pressure Sensor.....	247
12.3.3.2. Sample Flow Sensor.....	247
12.4. Electronic Operation.....	247
12.4.1. CPU.....	249
12.4.1.1. Disk-On-Module (DOM).....	249
12.4.1.2. Flash Chip.....	249
12.4.2. Optical Bench & GFC Wheel.....	250
12.4.2.1. Temperature Control.....	250
12.4.2.2. IR Source.....	250
12.4.2.3. GFC Wheel.....	250
12.4.2.4. IR Photo-Detector.....	252
12.4.3. Synchronous Demodulator (Sync/Demod) Assembly.....	252
12.4.3.1. Signal Synchronization and Demodulation.....	253
12.4.3.2. Sync/Demod Status LEDs.....	254
12.4.3.3. Photo-Detector Temperature Control.....	254
12.4.3.4. Dark Calibration Switch.....	255
12.4.3.5. Electric Test Switch.....	255
12.4.4. Relay Board.....	255
12.4.4.1. Heater Control.....	255
12.4.4.2. GFC Wheel Motor Control.....	255
12.4.4.3. Zero/Span Valve Options.....	256
12.4.4.4. IR Source.....	256
12.4.4.5. Status LEDs.....	256
12.4.4.6. I2C Watch Dog Circuitry.....	257
12.4.5. MotherBoard.....	257
12.4.5.1. A to D Conversion.....	257
12.4.5.2. Sensor Inputs.....	258
12.4.5.3. Thermistor Interface.....	258
12.4.5.4. Analog Outputs.....	259
12.4.5.5. Internal Digital I/O.....	259
12.4.5.6. External Digital I/O.....	259
12.4.6. I ² C Data Bus.....	259
12.4.7. Power Supply/ Circuit Breaker.....	260
12.4.8. Front Panel Touchscreen/Display Interface.....	262
12.4.8.1. LVDS Transmitter Board.....	262
12.4.8.2. Front Panel Touchscreen/Display Interface PCA.....	262
12.5. Software Operation.....	263
12.5.1. Adaptive Filter.....	263
12.5.2. Calibration - Slope and Offset.....	264
12.5.3. Measurement Algorithm.....	264
12.5.4. Temperature and Pressure Compensation.....	264
12.5.5. Internal Data Acquisition System (DAS).....	264
13. A PRIMER ON ELECTRO-STATIC DISCHARGE.....	265
13.1. How Static Charges are Created.....	265
13.2. How Electro-Static Charges Cause Damage.....	266
13.3. Common Myths About ESD Damage.....	267
13.4. Basic Principles of Static Control.....	268
13.4.1. General Rules.....	268
13.4.2. Basic anti-ESD Procedures for Analyzer Repair and Maintenance.....	269
13.4.2.1. Working at the Instrument Rack.....	269
13.4.2.2. Working at an Anti-ESD Work Bench.....	270
13.4.2.3. Transferring Components from Rack to Bench and Back.....	270

13.4.2.4. Opening Shipments from Teledyne Customer Service.....	271
13.4.2.5. Packing Components for Return to Teledyne Customer Service.....	271

GLOSSARY 273**LIST OF APPENDICES**

APPENDIX A - VERSION SPECIFIC SOFTWARE DOCUMENTATION
APPENDIX B - GFC7002T/GFC7002TU SPARE PARTS LIST
APPENDIX C - REPAIR QUESTIONNAIRE - GFC7002T
APPENDIX D - SCHEMATICS

LIST OF FIGURES

Figure 3-1:	Front Panel Layout.....	13
Figure 3-2:	Display Screen and Touch Control	14
Figure 3-3:	Display/Touch Control Screen Mapped to Menu Charts	16
Figure 3-4:	Rear Panel Layout.....	17
Figure 3-5:	Internal Layout – GFC7002T	19
Figure 3-6:	Internal Layout – GFC7002TU	20
Figure 3-7:	Optical Bench Layout (shorter bench, GFC7002TU, shown)	21
Figure 3-8:	Analog In Connector.....	23
Figure 3-9:	Analog Output Connector	24
Figure 3-10:	Current Loop Option Installed on Motherboard	25
Figure 3-11:	Status Output Connector	26
Figure 3-12:	Control Input Connector	28
Figure 3-13:	Concentration Alarm Relay.....	29
Figure 3-14:	Rear Panel Connector Pin-Outs for RS-232 Mode	32
Figure 3-15:	Default Pin Assignments for CPU COM Port connector (RS-232)	33
Figure 3-16:	Jumper and Cables for Multidrop Mode	35
Figure 3-17:	RS-232-Multidrop PCA Host/Analyzer Interconnect Diagram	36
Figure 3-18:	Pneumatic Connections–Basic Configuration–Using Bottled Span Gas.....	39
Figure 3-19:	Pneumatic Connections–Basic Configuration–Using Gas Dilution Calibrator.....	39
Figure 3-20:	GFC7002T/GFC7002TU Internal Gas Flow	40
Figure 3-21:	Pneumatic Connections – Option Z/S Valve with Shutoff Valve for Pressurized Span and Atmospheric Zero	41
Figure 3-22:	Pneumatics: Option Z/S without Shutoff Valve	41
Figure 3-23:	Internal Pneumatic Flow OPT 50A – Zero/Span Valves	44
Figure 3-24:	Internal Pneumatic Flow – Zero/Span/Shutoff Valves (Opt 50B).....	45
Figure 3-225:	Pneumatics: Option Z/S Valve with Common Shutoff Valve for Pressurized Zero and Span	46
Figure 3-26:	Zero/Span Calibration Procedure.....	57
Figure 4-1:	Front Panel Display	61
Figure 4-2:	Viewing GFC7002T/GFC7002TU Test Functions.....	63
Figure 4-3:	Viewing and Clearing GFC7002T/GFC7002TU WARNING Messages	66
Figure 5-1:	Analog Output Connector Pin Out.....	71
Figure 5-2:	COMM– Machine ID.....	85
Figure 5-3:	Accessing the Analog I/O Configuration Submenus	93
Figure 5-4:	Setup for Checking / Calibrating DCV Analog Output Signal Levels	100
Figure 5-5:	Setup for Checking / Calibration Current Output Signal Levels Using an Ammeter	102
Figure 5-6:	Alternative Setup Using 250Ω Resistor for Checking Current Output Signal Levels	104
Figure 5-7:	DIAG – Analog Inputs (Option) Configuration Menu	108
Figure 6-1:	COM1[2] – Communication Modes Setup	117
Figure 6-2:	COMM Port Baud Rate.....	118
Figure 6-3:	COMM – COM1 Test Port	119

Figure 6-4:	COMM – LAN / Internet Manual Configuration	122
Figure 6-5 :	COMM – LAN / Internet Automatic Configuration (DHCP)	123
Figure 7-1:	Default DAS Channel Setup	131
Figure 7-2:	APICOM Remote Control Program Interface.....	144
Figure 7-3:	APICOM User Interface for Configuring the DAS	145
Figure 7-4:	DAS Configuration Through a Terminal Emulation Program.....	146
Figure 9-1:	Pneumatic Connections – Basic Configuration – Using Bottled Span Gas.....	158
Figure 9-2:	Pneumatic Connections – Basic Configuration – Using Gas Dilution Calibrator	158
Figure 9-3:	Pneumatic Connections – Option Z/S: Ambient Zero/Pressurized Span Calibration Valves ...	163
Figure 9-4:	Pneumatic Connections – Option Z/S Without Shutoff Valve.....	164
Figure 9-5:	Pneumatic Connections – Option Z/S Valve with Common Shutoff Valve for Pressurized Zero and Span	164
Figure 9-6:	O ₂ Sensor Calibration Set Up	180
Figure 9-7:	CO ₂ Sensor Calibration Set Up.....	184
Figure 10-1:	Sample Particulate Filter Assembly	196
Figure 11-1:	Viewing and Clearing Warning Messages.....	202
Figure 11-2:	Example of Signal I/O Function	206
Figure 11-3:	CPU Status Indicator.....	207
Figure 11-4:	Sync/Demod Board Status LED Locations.....	208
Figure 11-5:	Relay Board Status LEDs.....	209
Figure 11-6:	GFC7002T/GFC7002TU – Basic Internal Gas Flow	212
Figure 11-7:	Internal Pneumatic Flow OPT 50A – Zero/Span Valves (OPT 50A & 50B)	212
Figure 11-8:	Internal Pneumatic Flow OPT 50B – Zero/Span/Shutoff Valves	213
Figure 11-9:	GFC7002T/GFC7002TU – Internal Pneumatics with O ₂ Sensor Option 65A.....	213
Figure 11-10:	GFC7002T/GFC7002TU – Internal Pneumatics with CO ₂ Sensor Option 67A	214
Figure 11-11:	Location of Diagnostic LEDs on CO ₂ Sensor PCA	229
Figure 11-12:	Critical Flow Restrictor Assembly/Disassembly.....	230
Figure 11-13:	Opening the GFC Wheel Housing.....	231
Figure 11-14:	Removing the Opto-Pickup Assembly.....	232
Figure 11-15:	Removing the GFC Wheel Housing.....	232
Figure 11-16:	Removing the GFC Wheel.....	233
Figure 11-17:	Location of Sync/Demod Housing Mounting Screws	234
Figure 11-18:	Location of Sync/Demod Gain Potentiometer.....	234
Figure 12-1:	Measurement Fundamentals	240
Figure 12-2:	GFC Wheel	241
Figure 12-3:	Measurement Fundamentals with GFC Wheel.....	242
Figure 12-4:	Affect of N ₂ O in the Sample on N ₂ O MEAS & N ₂ O REF	243
Figure 12-5:	Effects of Interfering Gas on N ₂ O MEAS & N ₂ O REF	244
Figure 12-6:	Chopped IR Signal	244
Figure 12-7:	Internal Pneumatic Flow – Basic Configuration	245
Figure 12-8:	Flow Control Assembly & Critical Flow Orifice.....	246
Figure 12-9:	Electronic Block Diagram	248
Figure 12-10:	CPU Board.....	249
Figure 12-11:	GFC Light Mask	251
Figure 12-12:	Segment Sensor and M/R Sensor Output.....	252
Figure 12-13:	GFC7002T/GFC7002TU Sync/Demod Block Diagram	253
Figure 12-14:	Sample & Hold Timing.....	254
Figure 12-15:	Location of relay board Status LEDs.....	257
Figure 12-16:	Power Distribution Block Diagram.....	261
Figure 12-17:	Front Panel and Display Interface Block Diagram	262
Figure 12-18:	Basic Software Operation	263
Figure 13-1:	Triboelectric Charging	265
Figure 13-2:	Basic anti-ESD Workbench	268

LIST OF TABLES

Table 1-1:	Analyzer Options	5
Table 2-1:	GFC7002T/GFC7002TU Basic Unit Specifications	9
Table 3-1:	Ventilation Clearance	12
Table 3-2:	Display Screen and Touch Control Description	15
Table 3-3:	Rear Panel Description.....	18
Table 3-4:	Analog Input Pin Assignments	23
Table 3-5:	Analog Output Pin-Outs.....	24
Table 3-6:	Status Output Signals.....	27
Table 3-7:	Control Input Signals	28
Table 3-8:	Zero/Span Valve Operating States for Option 50A	44
Table 3-9:	Zero/Span Valve Operating States for Option 50B	45
Table 3-10:	Zero/Span Valve Operating States for Option 50E	46
Table 3-11:	Possible Warning Messages at Start-Up.....	49
Table 3-12:	Possible Startup Warning Messages – GFC7002T Analyzers with Options	50
Table 4-1:	Analyzer Operating Modes	62
Table 4-2:	Test Functions Defined.....	64
Table 4-3:	List of Warning Messages	65
Table 4-4:	Primary Setup Mode Features and Functions	67
Table 4-5:	Secondary Setup Mode (SETUP>MORE) Features and Functions	68
Table 5-1:	GFC7002T Family Physical Range by Model.....	72
Table 5-2:	Password Levels	81
Table 5-3:	Variable Names (VARS).....	86
Table 5-4:	Diagnostic Mode (DIAG) Functions.....	88
Table 5-5:	DIAG - Analog I/O Functions	92
Table 5-6:	Analog Output Voltage Ranges	94
Table 5-7:	Voltage Tolerances for the TEST CHANNEL Calibration.....	100
Table 5-8:	Current Loop Output Check.....	104
Table 5-9:	Test Channels Functions available on the GFC7002T/GFC7002TU's Analog Output	110
Table 5-10:	N ₂ O Concentration Alarm Default Settings.....	112
Table 6-1:	COMM Port Communication Modes	116
Table 6-2:	Ethernet Status Indicators	120
Table 6-3:	LAN/Internet Default Configuration Properties	121
Table 7-1:	Front Panel LED Status Indicators for DAS.....	127
Table 7-2:	DAS Data Channel Properties	129
Table 7-3:	DAS Data Parameter Functions.....	136
Table 8-1:	Interactive Mode Software Commands	148
Table 8-2:	Teledyne's Serial I/O Command Types.....	149
Table 9-1:	AUTOCAL Modes	169
Table 9-2:	AutoCal Attribute Setup Parameters	170
Table 9-3:	Example AutoCal Sequence	171
Table 9-4:	Calibration Data Quality Evaluation	175
Table 10-1:	GFC7002T/GFC7002TU Maintenance Schedule	193
Table 10-2:	GFC7002T/GFC7002TU Test Function Record	194
Table 10-3:	Predictive uses for Test Functions	195
Table 11-1:	Warning Messages - Indicated Failures	202
Table 11-2:	Test Functions - Indicated Failures	204
Table 11-3:	Sync/Demod Board Status Failure Indications	208
Table 11-4:	I ² C Status LED Failure Indications.....	209
Table 11-5:	Relay Board Status LED Failure Indications.....	210
Table 11-6:	DC Power Test Point and Wiring Color Codes	220
Table 11-7:	DC Power Supply Acceptable Levels.....	220

Table 11-8:	Relay Board Control Devices.....	222
Table 11-9:	Opto Pickup Board Nominal Output Frequencies.....	223
Table 11-10:	Analog Output Test Function - Nominal Values Voltage Outputs.....	225
Table 11-11:	Analog Output Test Function - Nominal Values Voltage Outputs.....	226
Table 11-12:	Status Outputs Check	227
Table 12-1:	Absorption Path Lengths for GFC7002T and GFC7002TU.....	240
Table 12-2:	Sync DEMOD Sample and Hold Circuits.....	254
Table 12-3:	Sync/Demod Status LED Activity.....	254
Table 12-4:	Relay Board Status LEDs.....	256
Table 13-1:	Static Generation Voltages for Typical Activities	266
Table 13-2:	Sensitivity of Electronic Devices to Damage by ESD.....	266

PART I
GENERAL INFORMATION

This page intentionally left blank.

1. INTRODUCTION, FEATURES AND OPTIONS

This section provides an overview of the Model GFC7002T or GFC7002TU Analyzer, its features and its options, followed by a description of how this user manual is arranged.

1.1. GFC7002T FAMILY OVERVIEW

The family includes the GFC7002T and the GFC7002TU Gas Filter Correlation Carbon Monoxide Analyzer. The GFC7002T family of analyzers is a microprocessor-controlled analyzer that are designed to measure low level and trace level nitrous oxide (N₂O), respectively. The primary difference between the models is their maximum operating range; 1000 ppm for the GFC7002T and 200 ppm for the GFC7002TU. These instruments are designed to be used for monitoring background levels of N₂O in the atmosphere, byproducts of combustion products and contamination of bottled gases.

It uses a method based on the Beer-Lambert law, an empirical relationship that relates the absorption of light to the properties of the material through which the light is traveling over a defined distance. In this case the light is infrared radiation (IR) traveling through a sample chamber filled with gas bearing a varying concentration of N₂O.

The GFC7002T/GFC7002TU uses Gas Filter Correlation (GFC) to overcome the interfering effects of various other gases (such as water vapor) that also absorb IR. The analyzer passes the IR beam through a spinning wheel made up of two separate chambers: one containing a high concentration of N₂O known as the *reference*, and the other containing a neutral gas known as the *measure*. The concentration of N₂O in the sample chamber is computed by taking the ratio of the instantaneous measure and reference values and then compensating the ratio for sample temperature and pressure.

The GFC7002T/GFC7002TU Analyzer's multi-tasking software gives the ability to track and report a large number of operational parameters in real time. These readings are compared to diagnostic limits kept in the analyzers memory and should any fall outside of those limits the analyzer issues automatic warnings.

Built-in data acquisition capability, using the analyzer's internal memory, allows the logging of multiple parameters including averaged or instantaneous concentration values, calibration data, and operating parameters such as pressure and flow rate. Stored data are easily retrieved through the serial port or Ethernet port via APICOM software or from the front panel, allowing operators to perform predictive diagnostics and enhanced data analysis by tracking parameter trends. Multiple averaging periods of one minute to 365 days are available for over a period of one year.

1.2. FEATURES

Some of the features of the GFC7002T family of analyzers include:

- LCD color graphics with touch screen interface
- Microprocessor controlled for versatility
- Multi-tasking software allows viewing of test variables during operation
- Continuous self checking with alarms
- Bi-directional USB, RS-232, and 10/100Base-T Ethernet ports for remote operation (optional RS-485)
- Front panel USB ports for peripheral devices and software downloads
- Digital status outputs indicate instrument operating condition
- Adaptive signal filtering optimizes response time
- Gas Filter Correlation (GFC) Wheel for N₂O specific measurement
- GFC Wheel guaranteed against leaks for 5 years
- Temperature and pressure compensation
- Comprehensive internal data logging with programmable averaging periods
- Remote operation when used with TAI's APICOM software

GFC7002T FEATURES:

- Ranges, 0-1 ppm to 0-1000 ppm, user selectable
- User selectable dual range with auto ranging

GFC7002TU FEATURES:

- Ranges, 0-200 ppb to 0-200 ppm
- User selectable dual range with auto ranging

1.3. GFC7002T/GFC7002TU DOCUMENTATION

In addition to this operation manual, two other manuals are available for download from Teledyne's website at <http://www.teledyne-api.com/manuals/>, to support the operation of this instrument:

- APICOM software manual, part number 07463
- DAS Manual, part number 02837

1.4. OPTIONS

The options available for your analyzer are presented in Table 1-1 with name, option number, a description and/or comments, and if applicable, cross-references to technical details in this manual, such as setup and calibration. To order these options or to learn more about them, please contact the Sales department of Teledyne Analytical Instruments at:

TELEDYNE ELECTRONIC TECHNOLOGIES
Analytical Instruments

16830 Chestnut Street
 City of Industry, CA 91748

Telephone: (626) 934-1500
 Fax: (626) 961-2538

Web: www.teledyne-ai.com
 or your local representative.

Table 1-1: Analyzer Options

Option	Option Number	Description/Notes	Reference
Pumps		Pumps meet all typical AC power supply standards while exhibiting same pneumatic performance.	
	10A	External Pump 100V - 120V @ 60 Hz	N/A
	10B	External Pump 220V - 240V @ 50 Hz	N/A
	10C	External Pump 220V - 240V @ 60 Hz	N/A
	10D	External Pump 100V – 12V @ 50 Hz	N/A
	10E	External Pump 100V @ 60 Hz	N/A
	11	Pumpless, internal or external Pump Pack	N/A
	13	High Voltage Internal Pump 240V @ 50Hz	N/A
Rack Mount Kits		Options for mounting the analyzer in standard 19" racks	
	20A	Rack mount brackets with 26 in. chassis slides	N/A
	20B	Rack mount brackets with 24 in. chassis slides	N/A
	21	Rack mount brackets only (compatible with carrying strap, Option 29)	N/A
	23	Rack mount for external pump pack (no slides)	N/A
Carrying Strap/Handle		Side-mounted strap for hand-carrying analyzer	
	29	Extends from "flat" position to accommodate hand for carrying. Recesses to 9mm (3/8") dimension for storage. Can be used with rack mount brackets, Option 21. Cannot be used with rack mount slides.	N/A
		 <p>CAUTION - GENERAL SAFETY HAZARD A fully loaded GFC7002T with valve options weighs about 18 kg or 40 lbs. (GFC7002TU weighs 22.7 kg or 50 lbs). To avoid personal injury we recommend that two persons lift and carry the analyzer. Disconnect all cables and tubing from the analyzer before moving it.</p>	
Analog Inputs		Used for connecting external voltage signals from other instrumentation (such as meteorological instruments).	
	64	Also can be used for logging these signals in the analyzer's internal DAS	Sections 3.3.1.2, 5.8.3.10, and 7
Current Loop Analog Outputs		Adds isolated, voltage-to-current conversion circuitry to the analyzer's analog outputs.	
	41	Can be configured for any output range between 0 and 20 mA. May be ordered separately for any of the analog outputs.	Sections 3.3.1.3, 3.3.1.4, 5.8.1, 5.8.2 and 5.8.3.6

Option	Option Number	Description/Notes	Reference	
		Can be installed at the factory or retrofitted in the field.		
Parts Kits		Spare parts and expendables		
	42A	Expendables Kit includes a recommended set of expendables for one year of operation of this instrument including replacement sample particulate filters.	Appendix B	
	45	Spare Parts Kit includes spares parts for one unit.	Appendix B	
Calibration Valves		Used to control the flow of calibration gases generated from external sources, rather than manually switching the rear panel pneumatic connections.		
	50A	Ambient Zero and Ambient Span.	Sections 3.3.2.3 and 3.3.2.4	
	50B	Ambient Zero and Pressurized Span	Sections Error! Reference source not found. and 3.3.2.5	
	50E	Zero Scrubber and Pressurized Span	Sections Error! Reference source not found. and Error! Reference source not found.	
	50H	Zero Scrubber and Ambient Span	Sections Error! Reference source not found. and Error! Reference source not found.	
Communication Cables		For remote serial, network and Internet communication with the analyzer.		
		Type	Description	
	60A	RS-232	Shielded, straight-through DB-9F to DB-25M cable, about 1.8 m long. Used to interface with older computers or code activated switches with DB-25 serial connectors.	Section 3.3.1.9 and 6.3
	60B	RS-232	Shielded, straight-through DB-9F to DB-9F cable of about 1.8 m length.	Sections 3.3.1.9, and 6.3
	60C	Ethernet	Patch cable, 2 meters long, used for Internet and LAN communications.	Sections 3.3.1.9 and 6.5
	60D	USB	Cable for direct connection between instrument (rear panel USB port) and personal computer.	Sections 3.3.1.9 and 6.6
Concentration Alarm Relay		Issues warning when gas concentration exceeds limits set by user.		
	61	Four (4) "dry contact" relays on the rear panel of the instrument. This relay option is different from and in addition to the "Contact Closures" that come standard on all TAI instruments.	Section 3.3.1.7	
RS-232 Multidrop		Enables communications between host computer and up to eight analyzers.		
	62	Multidrop card seated on the analyzer's CPU card. Each instrument in the multidrop network requires this card and a communications cable (Option 60B).	Sections 3.3.1.9 and 5.6.2	

Option	Option Number	Description/Notes	Reference
Second Gas Sensors		Choice of one additional gas sensor.	
	65A	Oxygen (O ₂) Sensor	• Sections 3.3.1.3 and 9.6.1
	67A	Carbon Dioxide (CO ₂) Sensor	• Sections 3.3.1.3 and 9.6.2
Special Features		Built in features, software activated	
	N/A	Maintenance Mode Switch , located inside the instrument, places the analyzer in maintenance mode where it can continue sampling, yet ignore calibration, diagnostic, and reset instrument commands. This feature is of particular use for instruments connected to Multidrop networks. Call Customer Service for activation.	N/A
	N/A	Second Language Switch activates an alternate set of display messages in a language other than the instrument's default language. Call Customer Service for a specially programmed Disk on Module containing the second language.	N/A
	N/A	Dilution Ratio Option allows the user to compensate for diluted sample gas, such as in continuous emission monitoring (CEM) where the quality of gas in a smoke stack is being tested and the sampling method used to remove the gas from the stack dilutes the gas. Call Customer Service for activation.	Sections 3.4.4.2 and 5.4.5

Refer to page iii in this manual for configuration and specific options included with this instrument.

This page intentionally left blank.

2. SPECIFICATIONS AND APPROVALS

This section presents specifications for the GFC7002T/GFC7002TU analyzer and for its second gas sensor options, EPA equivalency designation, and compliance statements.

2.1. SPECIFICATIONS

Table 2-1: GFC7002T/GFC7002TU Basic Unit Specifications

Parameter	Model GFC7002T	Model GFC7002TU
Ranges	Min: 0-1 ppm Full scale	0-200 ppb Full scale
	Max: 0-1000 ppm Full scale (selectable, dual ranges and auto ranging supported)	0-200 ppm Full scale (selectable, dual ranges and auto ranging supported)
Measurement Units	ppb, ppm, $\mu\text{g}/\text{m}^3$, mg/m^3 (selectable)	
Zero Noise	< 0.02 ppm (RMS)	< 5 ppb (RMS)
Span Noise	< 0.5% of reading (RMS)	< 0.5% of reading RMS over 2 ppm
Lower Detectable Limit	< 0.04 ppm	< 10 ppb
Zero Drift	< 0.1 ppm/24 hours	< 25 ppb/24 hours
Span Drift (24 hours)	< 0.5% of reading/24 hours	< 0.5% of reading/24 hours
Lag Time	<10 sec	
Rise/Fall Time	<60 sec to 95%	
Linearity	1% of full scale	
Precision	0.5% reading	
Sample Flow Rate	800 cm^3/min . \pm 10%	
Electrical Specifications		
Power Requirements	100V-120V, 220V-240V, 50/60 Hz	
Analog Output Ranges	10V, 5V, 1V, 0.1V (selectable)	
Recorder Offset	\pm 10%	
Communication Specifications		
Included I/O	1 Ethernet: 10/100Base-T 2 RS-232 (300 – 115,200 baud) 2 USB device ports 8 opto-isolated digital status outputs 6 opto-isolated digital control inputs 4 analog outputs	
Optional I/O	1 USB com port 1 RS485 8 analog inputs (0-10V, 12-bit) 4 digital alarm outputs Modbus RS232 3 4-20mA current outputs	

Parameter	Model GFC7002T	Model GFC7002TU
Physical Specifications		
Temperature Range	5 - 40°C operating	
Dimensions (HxWxD)	7" x 17" x 23.5" (178 mm x 432 mm x 597 mm)	
Weight	50 lb (22.7 kg)	

2.2. EPA EQUIVALENCY DESIGNATION

There is no US EPA reference method for the measurement of nitrous oxide; therefore, neither the GFC7002T nor the GFC7002TU are designated as reference or equivalent methods.

2.3. APPROVALS AND CERTIFICATIONS

The TAI Model GFC7002T/GFC7002TU analyzer was tested and certified for Safety and Electromagnetic Compatibility (EMC). This section presents the compliance statements for those requirements and directives.

2.3.1. SAFETY

IEC 61010-1:2001, Safety requirements for electrical equipment for measurement, control, and laboratory use.

CE: 2006/95/EC, Low-Voltage Directive

North American:

cNEMKO (Canada): CAN/CSA-C22.2 No. 61010-1-04
NEMKO-CCL (US): UL No. 61010-1 (2nd Edition)

2.3.2. EMC

EN 61326-1 (IEC 61326-1), Class A Emissions/Industrial Immunity

EN 55011 (CISPR 11), Group 1, Class A Emissions

FCC 47 CFR Part 15B, Class A Emissions

CE: 2004/108/EC, Electromagnetic Compatibility Directive

2.3.3. OTHER TYPE CERTIFICATIONS

MCERTS: Sira MC 050069/04

For additional certifications, please contact Customer Service.

3. GETTING STARTED

This section first introduces you to the instrument, then presents the procedures for getting started, i.e., unpacking and inspection, making electrical and pneumatic connections, and conducting an initial calibration check.

3.1. UNPACKING THE GFC7002T/GFC7002TU ANALYZER



**CAUTION
GENERAL SAFETY HAZARD**

To avoid personal injury, always use two persons to lift and carry the GFC7002T/GFC7002TU.

ATTENTION

COULD DAMAGE INSTRUMENT AND VOID WARRANTY

Printed Circuit Assemblies (PCAs) are sensitive to electro-static discharges too small to be felt by the human nervous system. Failure to use ESD protection when working with electronic assemblies will void the instrument warranty. See *A Primer on Electro-Static Discharge* in this manual for more information on preventing ESD damage.



CAUTION!

Do not operate this instrument until you've removed dust plugs from SAMPLE and EXHAUST ports on the rear panel!

Note

TAI recommends that you store shipping containers/materials for future use if/when the instrument should be returned to the factory for repair and/or calibration service. Contact TAI for warranty repairs. This analyzer is shipped with all the materials you need to install and prepare the system for operation. Carefully unpack the analyzer and inspect it for damage. Immediately report any damage to the shipping agent. .

Verify that there is no apparent external shipping damage. If damage has occurred, please advise the shipper first, then TAI.

Included with your analyzer is a printed record (Final Test and Validation Data Sheet of the final performance characterization performed on your instrument at the factory. This record is an important quality assurance and calibration record for this instrument. It should be placed in the quality records file for this instrument.

With no power to the unit, carefully remove the top cover of the analyzer and check for internal shipping damage by carrying out the following steps:

1. Carefully remove the top cover of the analyzer and check for internal shipping damage by:
 - Removing the setscrew located in the top, center of the Front panel;
 - Removing the two flat head, Phillips screws on the sides of the instrument (one per side towards the rear);
 - Sliding the cover backwards until it clears the analyzer's front bezel, and;
 - Lifting the cover straight up.
2. Inspect the interior of the instrument to make sure all circuit boards and other components are in good shape and properly seated.
3. Check the connectors of the various internal wiring harnesses and pneumatic hoses to make sure they are firmly and properly seated.
4. Verify that all of the optional hardware ordered with the unit has been installed. These are listed on the paperwork accompanying the analyzer.



WARNING - ELECTRICAL SHOCK HAZARD

Never disconnect PCAs, wiring harnesses or electronic subassemblies while instrument is under power.

3.1.1. VENTILATION CLEARANCE

Whether the analyzer is set up on a bench or installed into an instrument rack, be sure to leave sufficient ventilation clearance.

Table 3-1: Ventilation Clearance

AREA	MINIMUM REQUIRED CLEARANCE
Back of the instrument	4 in.
Sides of the instrument	1 in.
Above and below the instrument	1 in.

Various rack mount kits are available for this analyzer. See Table 1-1 of this manual for more information.

3.2. INSTRUMENT LAYOUT

Instrument layout includes front panel and display, rear panel connectors, and internal chassis layout.

3.2.1. FRONT PANEL

Figure 3-1 shows the analyzer's front panel layout, followed by a close-up of the display screen in Figure 3-2, which is described in Table 3-2. The two USB ports on the front panel are provided for the connection of peripheral devices:

- Plug-in mouse (not included) to be used as an alternative to the touchscreen interface.
- Thumb drive (not included) to download updates to instruction software (contact TAI Customer Service for information).

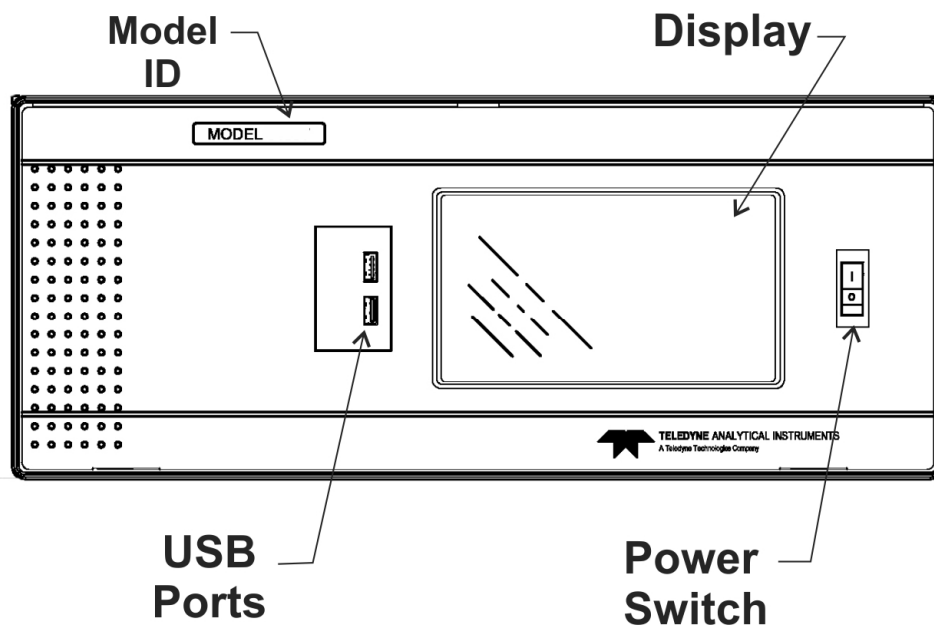

Figure 3-1: Front Panel Layout

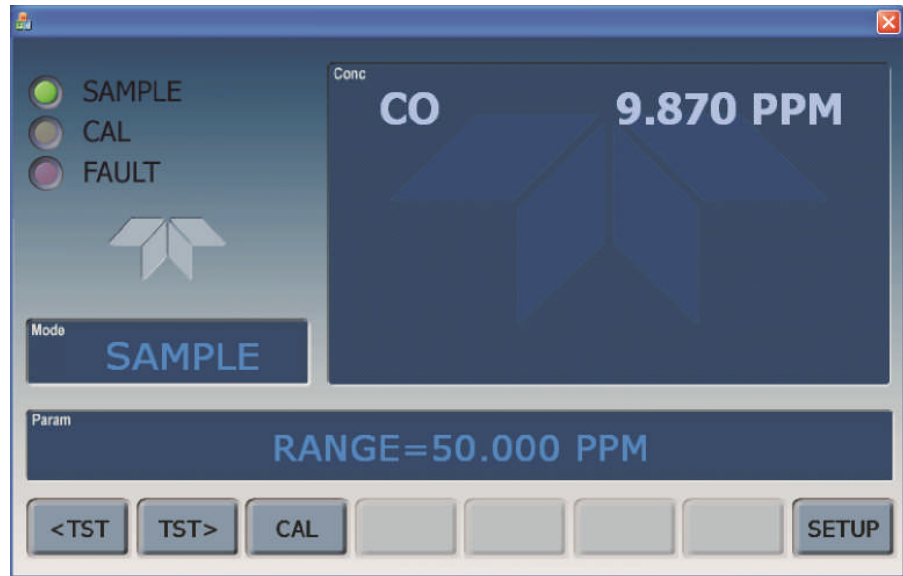

Figure 3-2: Display Screen and Touch Control

The front panel liquid crystal display screen includes touch control. Upon analyzer start-up, the screen shows a splash screen and other initialization indicators before the main display appears, similar to Figure 3-2 above (may or may not display a Fault alarm). The LEDs on the display screen indicate the Sample, Calibration and Fault states; also on the screen is the gas concentration field (Conc), which displays real-time readouts for the primary gas and for the secondary gas if installed. The display screen also shows what mode the analyzer is currently in, as well as messages and data (Param). Along the bottom of the screen is a row of touch control buttons; only those that are currently applicable will have a label. Table 3-2 provides detailed information for each component of the screen.

ATTENTION

**-----
 COULD DAMAGE INSTRUMENT AND VOID WARRANTY**

Do not use hard-surfaced instruments such as pens to touch the control buttons.

Table 3-2: Display Screen and Touch Control Description

Field	Description/Function			
Status	LEDs indicating the states of Sample, Calibration and Fault, as follows:			
	Name	Color	State	Definition
	SAMPLE	Green	Off	Unit is not operating in Sample Mode, DAS is disabled.
			On	Sample Mode active; Front Panel Display being updated; DAS data being stored.
			Blinking	Unit is operating in Sample Mode, front panel display being updated, DAS hold-off mode is ON, DAS disabled
CAL	Yellow	Off	Auto Cal disabled	
		On	Auto Cal enabled	
		Blinking	Unit is in calibration mode	
FAULT	Red	Off	No warnings exist	
		Blinking	Warnings exist	
Conc	Displays the actual concentration of the sample gas currently being measured by the analyzer in the currently selected units of measure			
Mode	Displays the name of the analyzer's current operating mode			
Param	Displays a variety of informational messages such as warning messages, operational data, test function values and response messages during interactive tasks.			
Control Buttons	Displays dynamic, context sensitive labels on each button, which is blank when inactive until applicable.			

Figure 3-3 shows how the front panel display is mapped to the menu charts that are illustrated throughout this manual. The Mode, Param (parameters), and Conc (gas concentration) fields in the display screen are represented across the top row of each menu chart. The eight touch control buttons along the bottom of the display screen are represented in the bottom row of each menu chart.

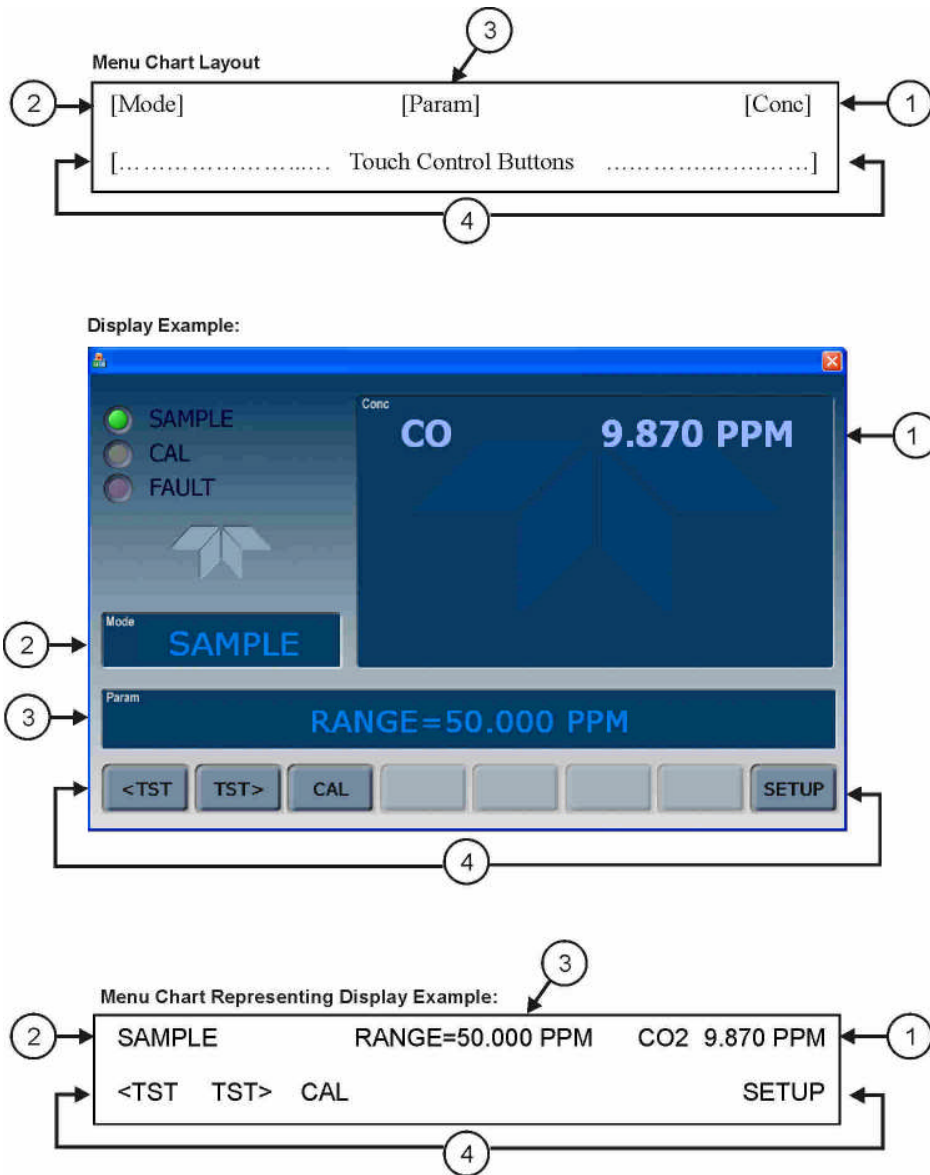

Figure 3-3: Display/Touch Control Screen Mapped to Menu Charts

Note

The menu charts in this manual contain condensed representations of the analyzer's display during the various operations being described. These menu charts are not intended to be exact visual representations of the actual display.

3.2.2. REAR PANEL

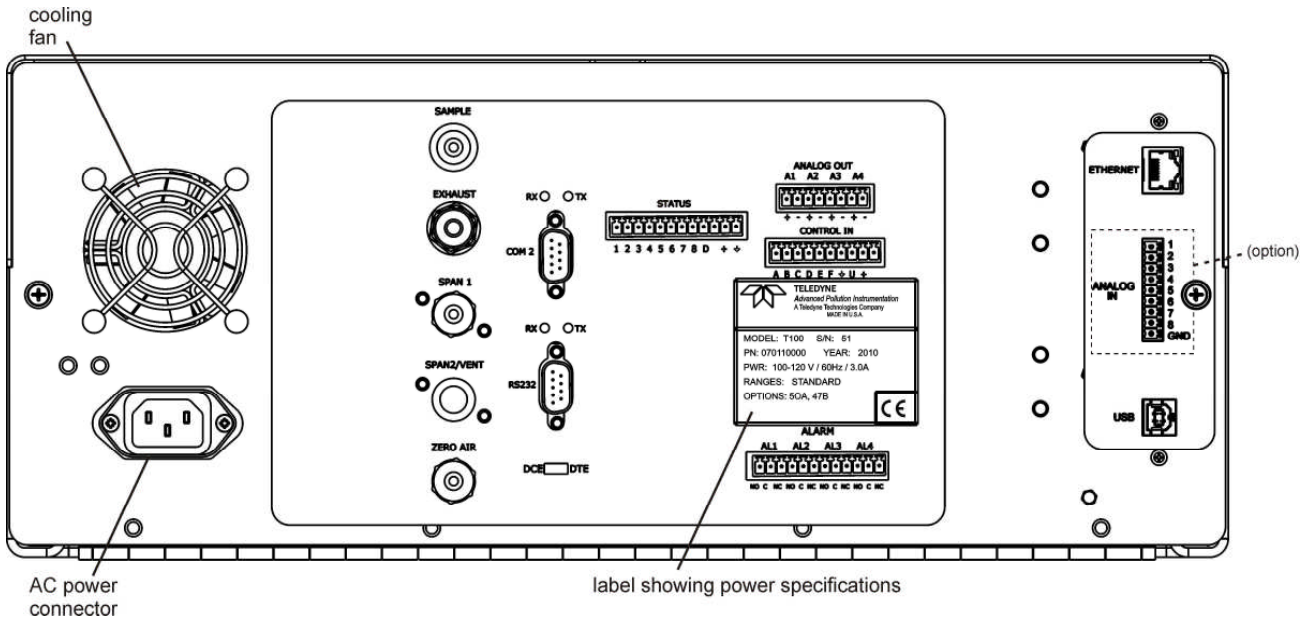



Figure 3-4: Rear Panel Layout

Table 3-3 provides a description of each component on the rear panel.

Table 3-3: Rear Panel Description

Component	Function
cooling fan	Pulls ambient air into chassis through side vents and exhausts through rear.
 AC power connector	Connector for three-prong cord to apply AC power to the analyzer. CAUTION! The cord's power specifications (specs) MUST comply with the power specs on the analyzer's rear panel Model number label
Model/specs label	Identifies the analyzer model number and provides voltage and frequency specs
SAMPLE	Connect a gas line from the source of sample gas here. Calibration gases are also inlet here on units without zero/span/shutoff valve options installed.
EXHAUST	Connect an exhaust gas line of not more than 10 meters long here that leads outside the shelter or immediate area surrounding the instrument.
SPAN 1	On units with zero/span/shutoff valve options installed, connect a gas line to the source of calibrated span gas here.
SPAN2/VENT	Used as a second cal gas input line when instrument is configured with zero/span valves and a dual gas option, or as a cal gas vent line when instrument is configured with a pressurized span option (<i>Call factory for details</i>).
ZERO AIR	Internal Zero Air: On units with zero/span/shutoff valve options installed but no internal zero air scrubber attach a gas line to the source of zero air here.
RX TX	LEDs indicate receive (RX) and transmit (TX) activity on the when blinking.
COM 2	Serial communications port for RS-232 or RS-485. (Sections 3.3.1.9, 5.6.4, 6).
RS-232	Serial communications port for RS-232 only. (Sections 3.3.1.9, 0, 6.3, Error! Reference source not found.)
DCE DTE	Switch to select either data terminal equipment or data communication equipment during RS-232 communication. (Section 6.1).
STATUS	For outputs to devices such as Programmable Logic Controllers (PLCs). (Section 3.3.1.5).
ANALOG OUT	For voltage or current loop outputs to a strip chart recorder and/or a data logger. (Sections 3.3.1.3 and 3.3.1.4).
CONTROL IN	For remotely activating the zero and span calibration modes. (Section 3.3.1.6).
ALARM	Option for concentration alarms and system warnings. (Section 3.3.1.7).
ETHERNET	Connector for network or Internet remote communication, using Ethernet cable (Section 3.3.1.9).
ANALOG IN	Option for external voltage signals from other instrumentation and for logging these signals (Section 3.3.1.2)
USB	Connector for direct connection to laptop computer, using USB cable. (Section 3.3.1.9).

3.2.3. GFC7002T/GFC7002TU ANALYZER LAYOUT

Figure 3-5 shows the GFC7002T internal layout.

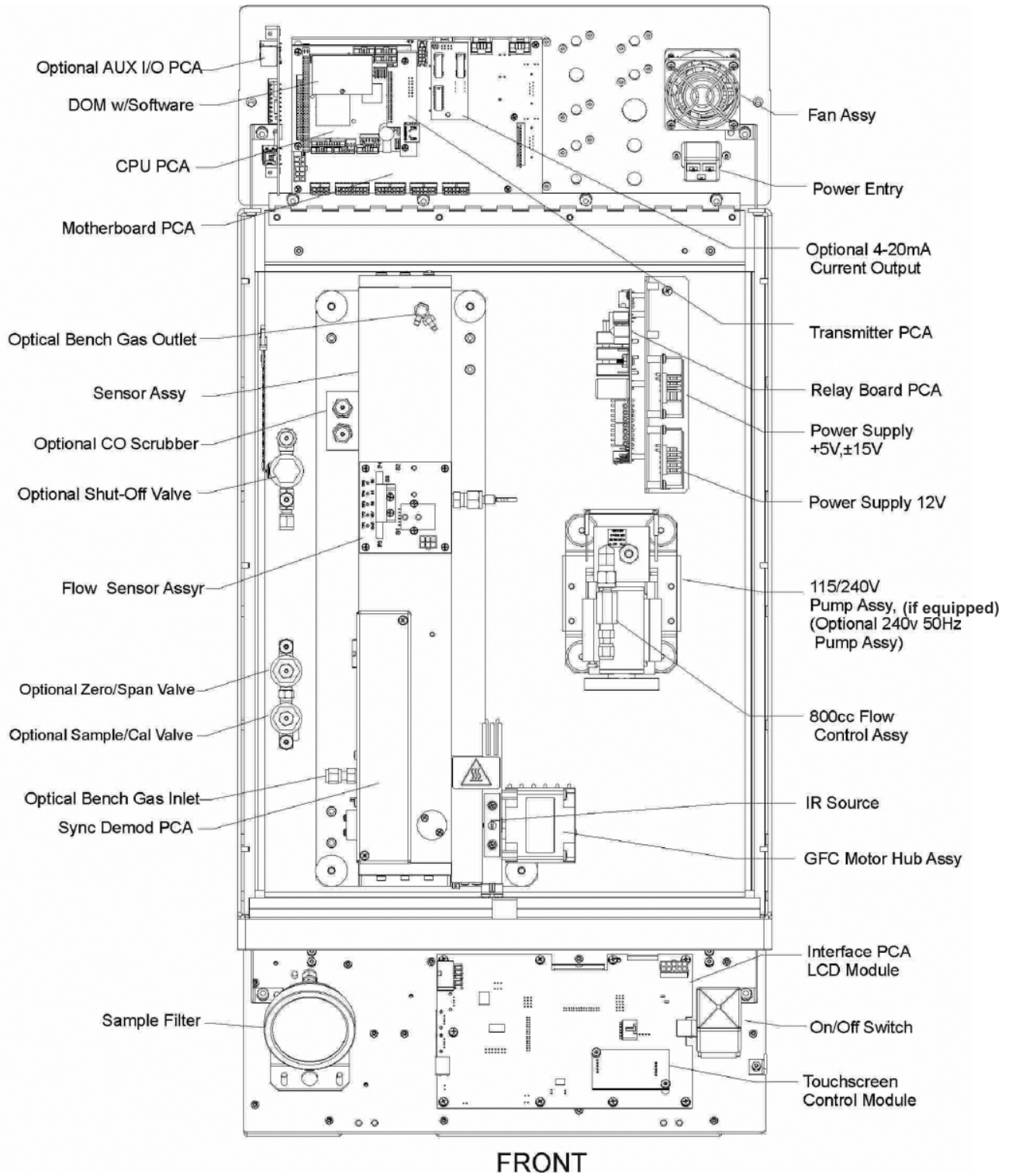

Figure 3-5: Internal Layout – GFC7002T

Figure 3-6 shows the GFC7002TU internal layout.

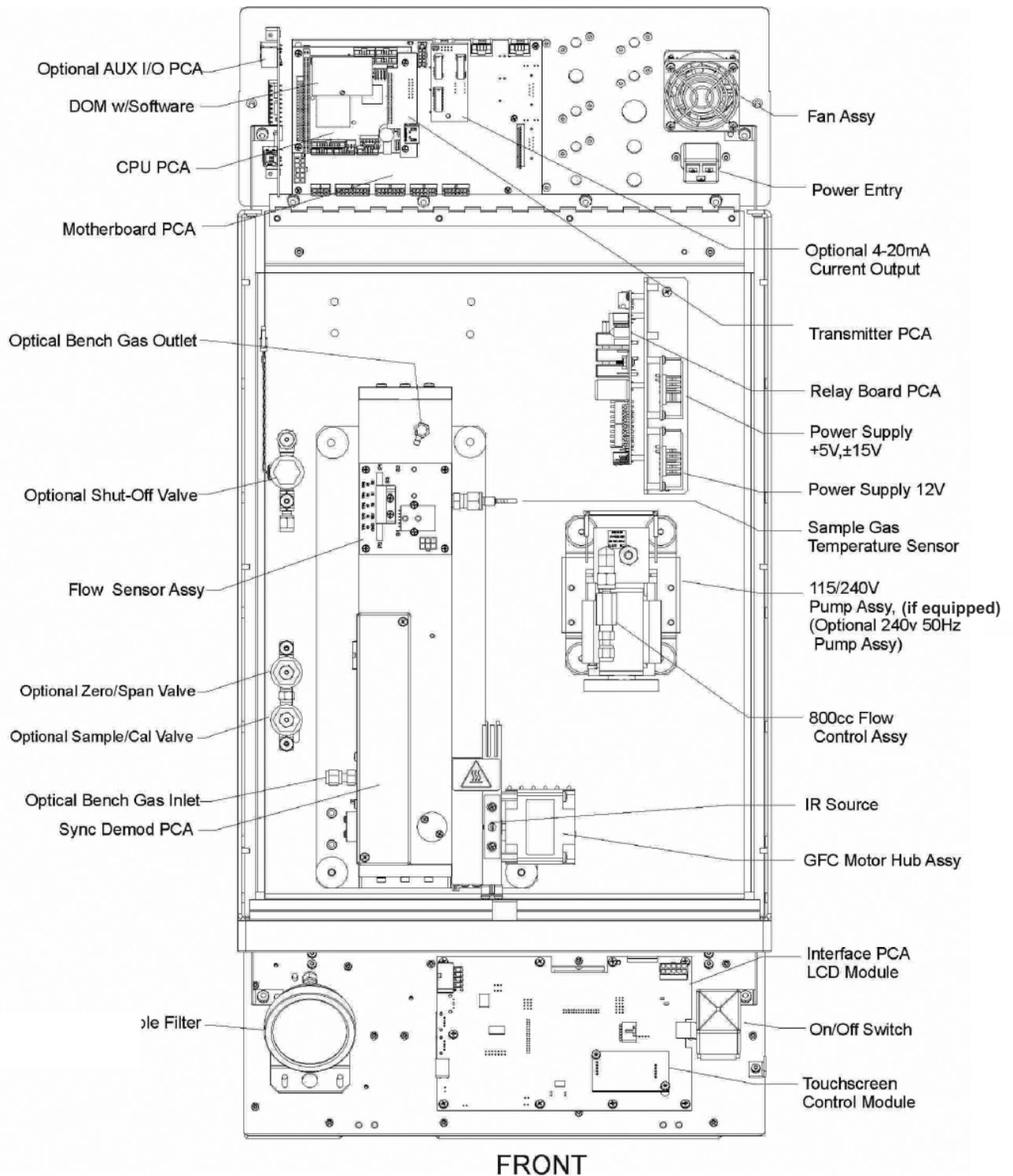

Figure 3-6: Internal Layout – GFC7002TU

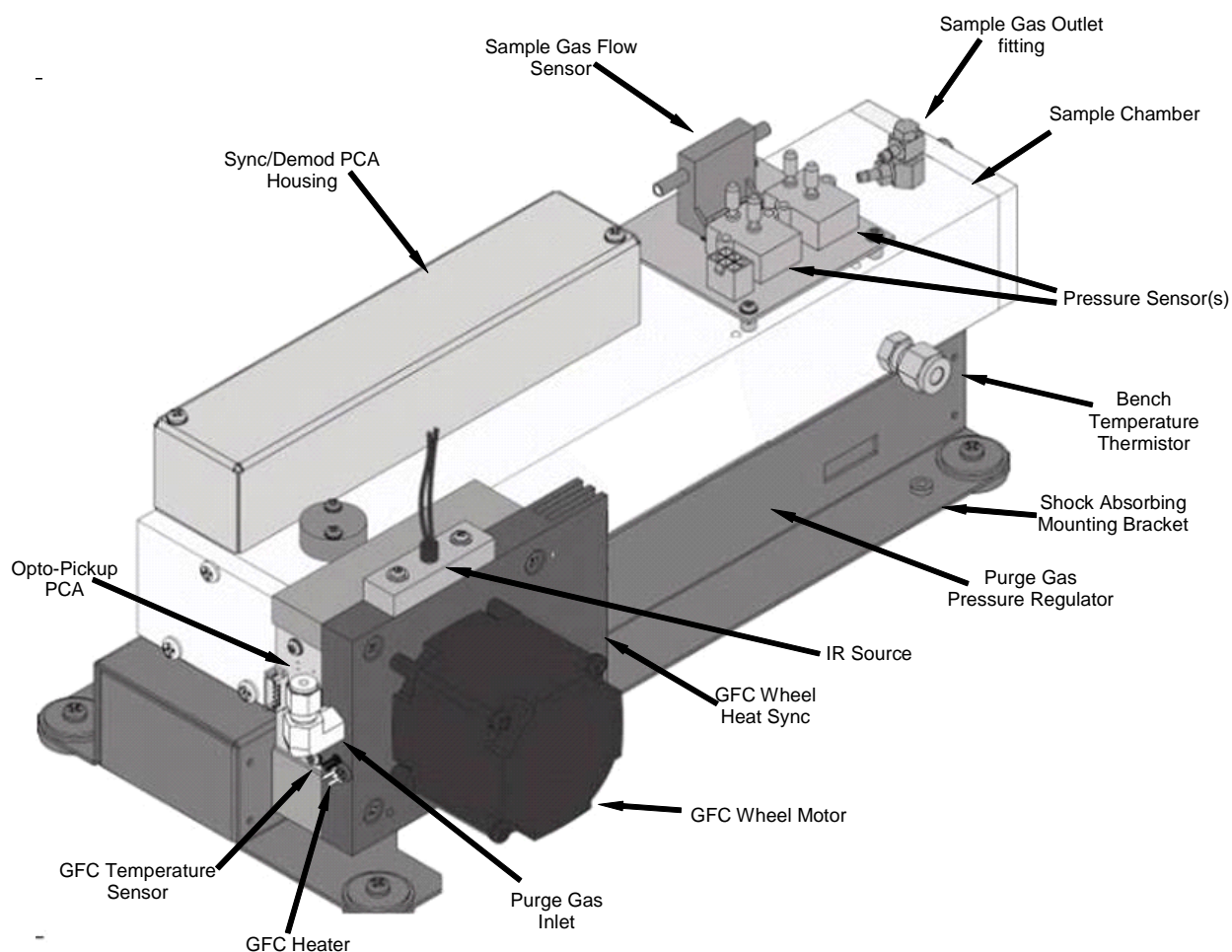

Figure 3-7: Optical Bench Layout (shorter bench, GFC7002TU, shown)

3.3. CONNECTIONS AND SETUP

This section presents the electrical (Section 3.3.1) and pneumatic (Section 3.3.2) connections for setup and preparing for instrument operation

3.3.1. ELECTRICAL CONNECTIONS

Note

To maintain compliance with EMC standards, it is required that the cable length be no greater than 3 meters for all I/O connections, which include Analog In, Analog Out, Status Out, Control In, Ethernet/LAN, USB, RS-232, and RS-485.

3.3.1.1. CONNECTING POWER

Attach the power cord to the analyzer and plug it into a power outlet capable of carrying at least 10 A current at your AC voltage and that it is equipped with a functioning earth ground.



WARNING
ELECTRICAL SHOCK HAZARD

High Voltages are present inside the analyzer's case.
Power connection must have functioning ground connection.
Do not defeat the ground wire on power plug.
Turn off analyzer power before disconnecting or connecting electrical subassemblies.
Do not operate with cover off.



CAUTION
GENERAL SAFETY HAZARD

The GFC7002T/GFC7002TU Analyzer can be configured for both 100-130 V and 210-240 V at either 47 Hz or 63 Hz.
To avoid damage to your analyzer, make sure that the AC power voltage matches the voltage indicated on the analyzer's model/specs label (See Figure 3-4) before plugging the GFC7002T/GFC7002TU into line power.

3.3.1.2. CONNECTING ANALOG INPUTS (OPTION)

The Analog In connector is used for connecting external voltage signals from other instrumentation (such as meteorological instruments) and for logging these signals in the analyzer's internal DAS. The input voltage range for each analog input is 0-10 VDC.

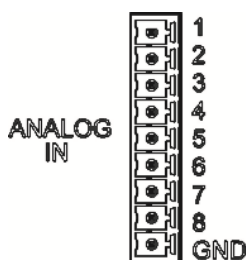

Figure 3-8: Analog In Connector

Pin assignments for the Analog In connector are presented in Table 3-4.

Table 3-4: Analog Input Pin Assignments

PIN	DESCRIPTION	DAS PARAMETER ¹
1	Analog input # 1	AIN 1
2	Analog input # 2	AIN 2
3	Analog input # 3	AIN 3
4	Analog input # 4	AIN 4
5	Analog input # 5	AIN 5
6	Analog input # 6	AIN 6
7	Analog input # 7	AIN 7
8	Analog input # 8	AIN 8
GND	Analog input Ground	N/A

¹ See Section 7 for details on setting up the DAS.

3.3.1.3. CONNECTING ANALOG OUTPUTS

The GFC7002T is equipped with several analog output channels accessible through a connector on the back panel of the instrument. The standard configuration for these outputs is mVDC. An optional current loop output is available for each.

When the instrument is in its default configuration, channels **A1** and **A2** output a signal that is proportional to the N₂O concentration of the sample gas. Either can be used for connecting the analog output signal to a chart recorder or for interfacing with a datalogger.

Output **A3** is only used on the GFC7002T/GFC7002TU if the optional CO₂ or O₂ sensor is installed.

Channel **A4** is special. It can be set by the user (see Section 5.8.8.1) to output any one of the parameters accessible through the <**TST TST**> buttons of the units sample display.

To access these signals attach a strip chart recorder and/or data-logger to the appropriate analog output connections on the rear panel of the analyzer.

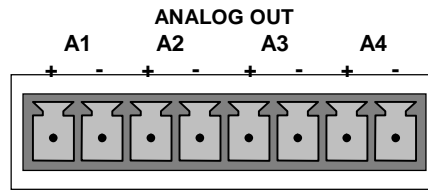

Figure 3-9: Analog Output Connector

Table 3-5: Analog Output Pin-Outs

PIN	ANALOG OUTPUT	VOLTAGE SIGNAL	CURRENT SIGNAL
1	A1	V Out	I Out +
2		Ground	I Out -
3	A2	V Out	I Out +
4		Ground	I Out -
5	A3 (Only used if CO ₂ or O ₂ Sensor is installed)	V Out	I Out +
6		Ground	I Out -
7	A4	V Out	I Out +
8		Ground	I Out -

3.3.1.4. CURRENT LOOP ANALOG OUTPUTS (OPTION 41) SETUP

If your analyzer had this option installed at the factory, there are no further connections to be made. Otherwise, it can be installed as a retrofit for each of the analog outputs of the analyzer. This option converts the DC voltage analog output to a current signal with 0-20 mA output current. The outputs can be scaled to any set of limits within that 0-20 mA range. However, most current loop applications call for either 2-20 mA or 4-20 mA range.

Figure 3-10 provides installation instructions and illustrates a sample combination of one current output and two voltage outputs configuration. Following Figure 3-10 are instructions for converting current loop analog outputs to standard 0-to-5 VDC outputs. Information on calibrating or adjusting these outputs can be found in Section 5.8.3.6

CAUTION – AVOID INVALIDATING WARRANTY



Servicing or handling of circuit components requires electrostatic discharge protection, i.e. ESD grounding straps, mats and containers. Failure to use ESD protection when working with electronic assemblies will void the instrument warranty. Refer to Section 13 for more information on preventing ESD damage.

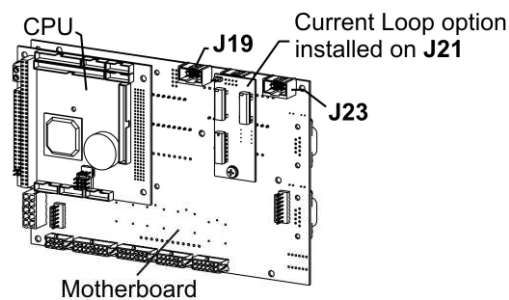
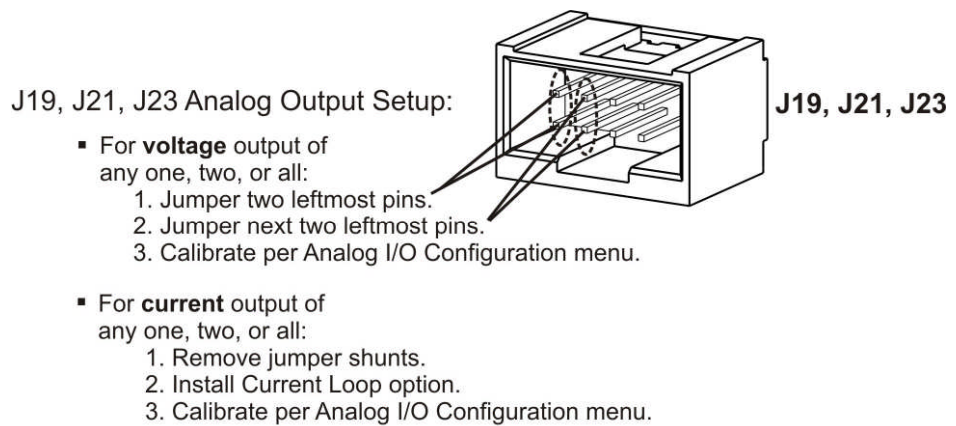

Example setup: install jumper shunts for voltage output on J19 and J23; remove jumper shunts and install Current Loop option for current output on J21.

Figure 3-10: Current Loop Option Installed on Motherboard

CONVERTING CURRENT LOOP ANALOG OUTPUTS TO STANDARD VOLTAGE OUTPUTS

To convert an output configured for current loop operation to the standard 0 to 5 VDC output operation:

1. Turn off power to the analyzer.
2. If a recording device was connected to the output being modified, disconnect it.
3. Remove the top cover.
 - Remove the screw located in the top, center of the front panel.
 - Remove the screws fastening the top cover to the unit (both sides).
 - Slide the cover back and lift straight up.
4. Remove the screw holding the current loop option to the motherboard.
5. Disconnect the current loop option PCA from the appropriate connector on the motherboard (see Figure 3-10).
6. Each connector, J19 and J23, requires two shunts. Place one shunt on the two leftmost pins and the second shunt on the two pins next to it (see Figure 3-10).
7. Reattach the top case to the analyzer.
 - The analyzer is now ready to have a voltage-sensing, recording device attached to that output.
8. Calibrate the analog output as described in Section 5.8.3.1.

3.3.1.5. CONNECTING THE STATUS OUTPUTS

The status outputs report analyzer conditions via optically isolated NPN transistors, which sink up to 50 mA of DC current. These outputs can be used interface with devices that accept logic-level digital inputs, such as Programmable Logic Controllers (PLCs). Each status bit is an open collector output that can withstand up to 40 VDC. All of the emitters of these transistors are tied together and available at D.

ATTENTION

----- COULD DAMAGE INSTRUMENT AND VOID WARRANTY

Most PLC's have internal provisions for limiting the current that the input will draw from an external device. When connecting to a unit that does not have this feature, an external dropping resistor must be used to limit the current through the transistor output to less than 50 mA. At 50 mA, the transistor will drop approximately 1.2V from its collector to emitter.

The status outputs are accessed via a 12-pin connector on the analyzer's rear panel labeled STATUS (see Figure 3-4). Pin-outs for this connector are:

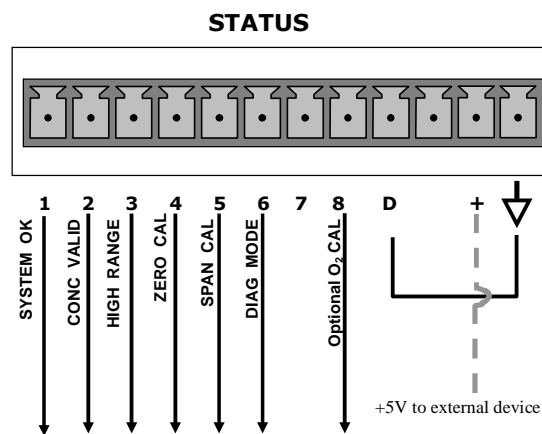



Figure 3-11: Status Output Connector

Table 3-6: Status Output Signals

REAR PANEL LABEL	STATUS DEFINITION	CONDITION
1	SYSTEM OK	ON if no faults are present.
2	CONC VALID	OFF any time the HOLD OFF feature is active, such as during calibration or when other faults exist possibly invalidating the current concentration measurement (example: sample flow rate is outside of acceptable limits). ON if concentration measurement is valid.
3	HIGH RANGE	ON if unit is in high range of either the DUAL or AUTO range modes.
4	ZERO CAL	ON whenever the instrument's ZERO point is being calibrated.
5	SPAN CAL	ON whenever the instrument's SPAN point is being calibrated.
6	DIAG MODE	ON whenever the instrument is in DIAGNOSTIC mode.
7	CO ₂ CAL	If this analyzer is equipped with an optional CO ₂ sensor, this Output is ON when that sensor is in calibration mode. Otherwise this output is unused.
8	O ₂ CAL	If this analyzer is equipped with an optional O ₂ sensor, this Output is ON when that sensor is in calibration mode. Otherwise this output is unused.
D	EMITTER BUS	The emitters of the transistors on pins 1-8 are bussed together.
	SPARE	
+	DC POWER	+ 5 VDC, 300 mA source maximum.
	Digital Ground	The ground level from the analyzer's internal DC power supplies.

3.3.1.6. CONNECTING THE CONTROL INPUTS

To remotely activate the zero and span calibration modes, several digital control inputs are provided through a 10-pin connector labeled **CONTROL IN** on the analyzer's rear panel.

There are two methods for energizing the control inputs. The internal +5V available from the pin labeled "+" is the most convenient method. However, if full isolation is required, an external 5 VDC power supply should be used.

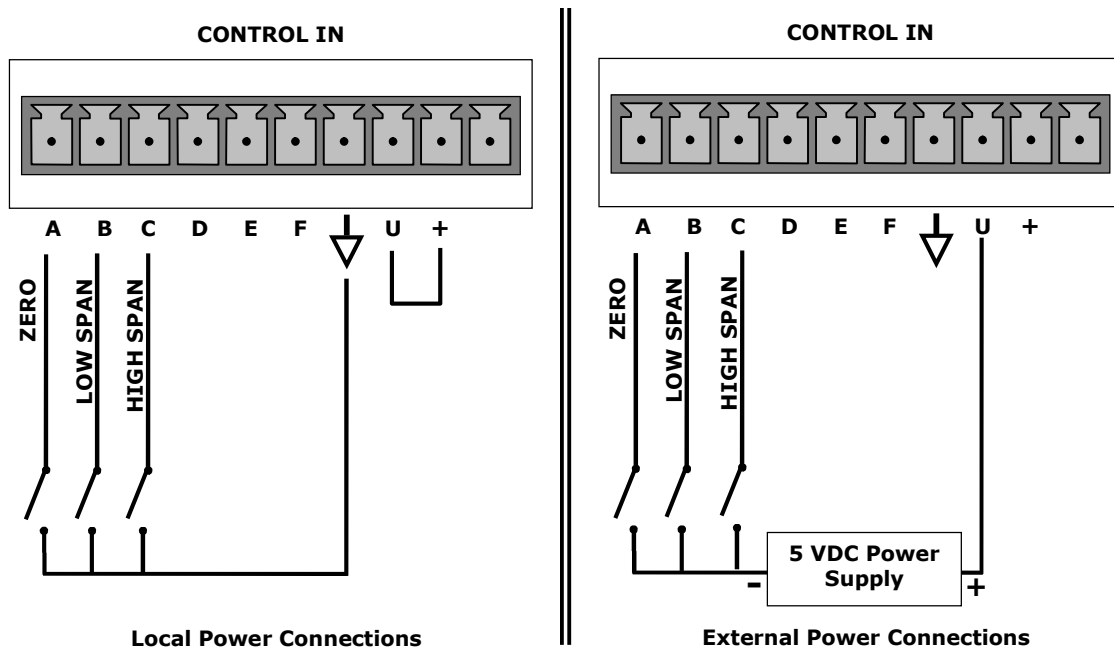

Figure 3-12: Control Input Connector

Table 3-7: Control Input Signals

INPUT #	STATUS DEFINITION	ON CONDITION
A	REMOTE ZERO CAL	The analyzer is placed in Zero Calibration mode. The mode field of the display will read ZERO CAL R.
B	REMOTE SPAN CAL	The analyzer is placed in span calibration mode as part of performing a low span (midpoint) calibration. The mode field of the display will read LO CAL R.
C	REMOTE CAL HIGH RANGE	The analyzer is forced into high range for zero or span calibrations. This only applies when the range mode is either DUAL or AUTO. The mode field of the display will read HI CAL R.
D, E & F	SPARE	
	Digital Ground	The ground level from the analyzer's internal DC power supplies (same as chassis ground).
U	External Power input	Input pin for +5 VDC required to activate pins A – F.
+	5 VDC output	Internally generated 5V DC power. To activate inputs A – F, place a jumper between this pin and the “U” pin. The maximum amperage through this port is 300 mA (combined with the analog output supply, if used).

3.3.1.7. CONCENTRATION ALARM RELAY (OPTION 61) STANDARD CONFIGURATION

The concentration alarm option is comprised of four (4) “dry contact” relays on the rear panel of the instrument. This relay option is different from and in addition to the “Contact Closures” that come standard on all TAI instruments. Each relay has 3 pins: Normally Open (NO), Common (C), and Normally Closed (NC).

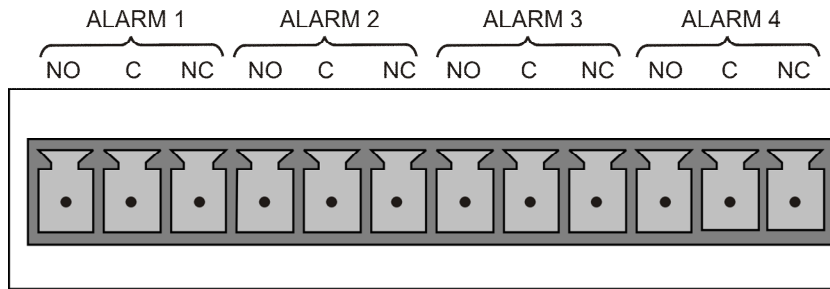

Figure 3-13: Concentration Alarm Relay

Alarm 1	“System OK 2”
Alarm 2	“Conc 1”
Alarm 3	“Conc 2”
Alarm 4	“Range Bit”

“ALARM 1” RELAY

Alarm 1 which is “System OK 2” (system OK 1, is the status bit) is in the energized state when the instrument is “OK” & there are no warnings. If there is a warning active or if the instrument is put into the “DIAG” mode, Alarm 1 will change states. This alarm has “reverse logic” meaning that if you put a meter across the Common & Normally Closed pins on the connector you will find that it is OPEN when the instrument is OK. This is so that if the instrument should turn off or lose power, it will change states and you can record this with a data logger or other recording device.

“ALARM 2” RELAY & “ALARM 3” RELAY

Alarm 2 relay is associated with the “Concentration Alarm 1” set point in the software; Alarm 3 Relay is associated with the “Concentration Alarm 2” set point in the software.

Alarm 2 Relay N₂O Alarm 1 = xxx PPM

Alarm 3 Relay N₂O Alarm 2 = xxx PPM

The Alarm 2 Relay will be turned on any time the concentration set-point is exceeded & will return to its normal state when the concentration value goes back below the concentration set-point.

Even though the relay on the rear panel is a NON-Latching alarm & resets when the concentration goes back below the alarm set point, the warning on the front panel of the instrument will remain latched until it is cleared. You can clear the warning on the front panel by either pushing the CLR button on the front panel or through the serial port.

In instruments that sample more than one gas type, there could be more than one gas type triggering the Concentration 1 Alarm (“Alarm 2” Relay). For example, the GFC7002TU instrument can monitor both N₂O & CO₂ gas. The software is flexible enough to allow you to configure the alarms so that you can have 2 alarm levels for each gas.

N₂O Alarm 1 = 20 PPM

N₂O Alarm 2 = 100 PPM

CO₂ Alarm 1 = 20 PPM

CO₂ Alarm 2 = 100 PPM

In this example, N₂O Alarm 1 & CO₂ Alarm 1 will both be associated with the “Alarm 2” relay on the rear panel. This allows you do have multiple alarm levels for individual gasses.

A more likely configuration for this would be to put one gas on the “Alarm 1” relay & the other gas on the “Alarm 2” relay.

N₂O Alarm 1 = 20 PPM

N₂O Alarm 2 = Disabled

CO₂ Alarm 1 = Disabled

CO₂ Alarm 2 = 100 PPM

“ALARM 4” RELAY

This relay is typically used as the “range bit”. If the instrument is configured for “Auto Range” and the instrument goes up into the high range, it will turn this relay on. However if the unit is configured with the AP option, AL4 will have a different function. See Section 5.9.2.

3.3.1.8. CONCENTRATION ALARM RELAY (OPTION 61) AIR PRODUCTS CONFIGURATION

In the Air Products configuration, the 4 relay alarm outputs (AL1-AL4) on the rear panel are configured differently..

- AL1 is for “system okay”,
- AL2 is for “high range status”
- AL3 is for “zero calibration status”
- AL4 is for “concentration alarm 1”

The AL1 relay is energized when the system is okay and de-energized when the system has a fault. The AL2 relay is energized when the high auto-range is in use and and AL3 relays energize when the the instrument is in zero calibration mode.

Also, in the Air Products configuration, an additional control input is available on this instrument. Control input “C” is used to select the range for remote calibration. When input C is low, the instrument selects high range during contact closure calibration. See Section 6.15.12.

Other AP options are available. See Section 5.9.1.

3.3.1.9. CONNECTING THE COMMUNICATION INTERFACES

The T-Series analyzers are equipped with connectors for remote communications interfaces: **Ethernet**, **USB**, **RS-232**, optional **RS-232 Multidrop**, and optional **RS-485**. In addition to using the appropriate cables, each type of communication method must be configured using the SETUP>COMM menu, Section 6. Although Ethernet is DHCP-enabled by default, it can also be configured manually (Section 6.5.1) to set up a static IP address, which is the recommended setting when operating the instrument via Ethernet.

ETHERNET CONNECTION

For network or Internet communication with the analyzer, connect an Ethernet cable from the analyzer's rear panel Ethernet interface connector to an Ethernet access port. Please see Section 6.5 for description and setup instructions.

For manual configuration, see Section 6.5.1.

For automatic configuration (default), see Section 6.5.2.

USB CONNECTION

For direct communication between the analyzer and a PC, connect a USB cable between the analyzer and desktop or laptop USB ports. The baud rate for the analyzer and the computer must match; you may elect to change one or the other: to view and/or change the analyzer's baud rate, see Section 6.2.2.

Note

If this option is installed, the COM2 port cannot be used for anything other than Multidrop communication.

For configuration, see 6.6.

RS-232 CONNECTION

For **RS-232** communications with data terminal equipment (**DTE**) or with data communication equipment (**DCE**) connect either a DB9-female-to-DB9-female cable (TAI part number WR000077) or a DB9-female-to-DB25-male cable (Option 60A, Section 1.4), as applicable, from the analyzer's rear panel RS-232 port to the device. Adjust the DCE-DTE switch (Figure 3-4) to select DTE or DCE as appropriate.

Configuration: Sections 0 and 6.3.

IMPORTANT

IMPACT ON READINGS OR DATA
Cables that appear to be compatible because of matching connectors may incorporate internal wiring that makes the link inoperable. Check cables acquired from sources other than TAI for pin assignments (Figure 3-14) before using.

RS-232 COM PORT CONNECTOR PIN-OUTS

Electronically, the difference between the DCE and DTE is the pin assignment of the Data Receive and Data Transmit functions.

- DTE devices receive data on pin 2 and transmit data on pin 3.
- DCE devices receive data on pin 3 and transmit data on pin 2.

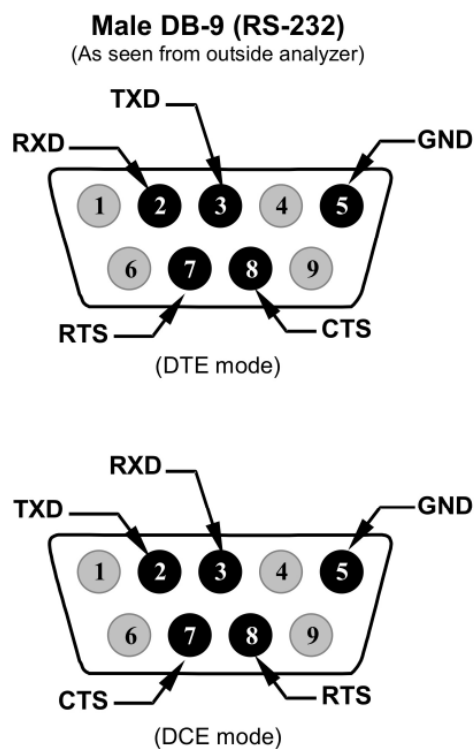

Figure 3-14: Rear Panel Connector Pin-Outs for RS-232 Mode

The signals from these two connectors are routed from the motherboard via a wiring harness to two 10-pin connectors on the CPU card, J11 (COM1) and J12 (COM2) (Figure 3-15).

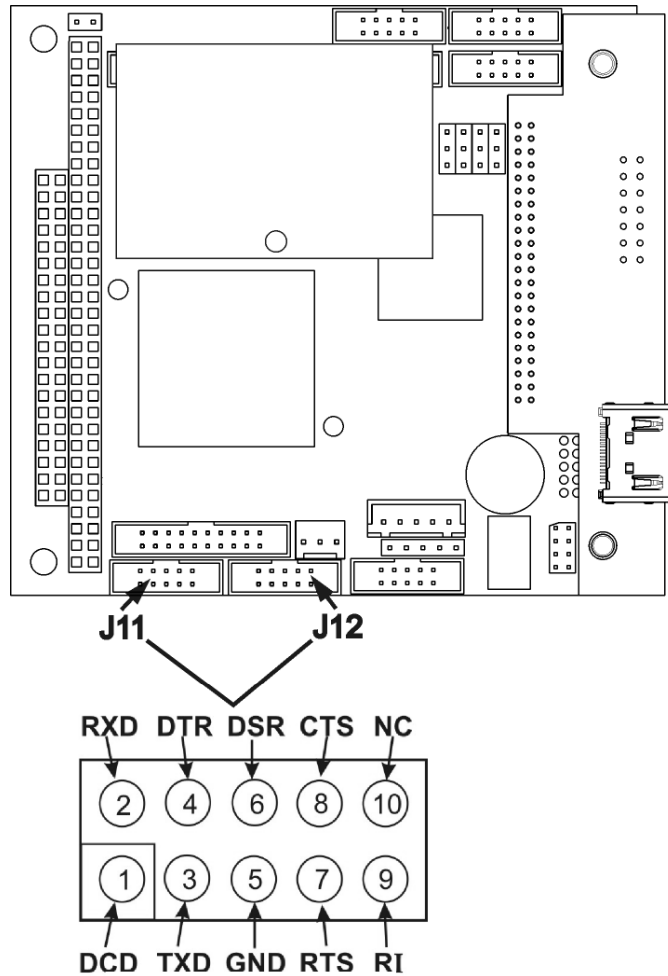

Figure 3-15: Default Pin Assignments for CPU COM Port connector (RS-232)

RS-232 COM PORT DEFAULT SETTINGS

Received from the factory, the analyzer is set up to emulate a DCE or modem, with Pin 3 of the DB-9 connector designated for receiving data and Pin 2 designated for sending data.

- **RS-232 (COM1):** RS-232 (fixed) DB-9 male connector.
 - **Baud rate:** 115200 bits per second (baud)
 - **Data Bits:** 8 data bits with 1 stop bit
 - **Parity:** None
- **COM2:** RS-232 (configurable to RS-485), DB-9 female connector.
 - **Baud rate:** 19200 bits per second (baud)
 - **Data Bits:** 8 data bits with 1 stop bit
 - **Parity:** None

RS-232 MULTIDROP OPTION CONNECTION

When the RS-232 Multidrop option is installed, connection adjustments and configuration through the menu system are required. This section provides instructions for the internal connection adjustments, then for external connections, and ends with instructions for menu-driven configuration.

Note

Because the RS-232 Multidrop option uses both the RS232 and COM2 DB9 connectors on the analyzer's rear panel to connect the chain of instruments, COM2 port is no longer available for separate RS-232 or RS-485 operation.

ATTENTION

----- **COULD DAMAGE INSTRUMENT AND VOID WARRANTY**

Printed Circuit Assemblies (PCAs) are sensitive to electro-static discharges too small to be felt by the human nervous system. Failure to use ESD protection when working with electronic assemblies will void the instrument warranty. Refer to Section 13 for more information on preventing ESD damage.

In each instrument with the Multidrop option there is a shunt jumpering two pins on the serial Multidrop and LVDS printed circuit assembly (PCA), as shown in Figure 3-16. This shunt must be removed from all instruments except that designated as last in the multidrop chain, which must remain terminated. This requires powering off and opening each instrument and making the following adjustments:

1. With **NO power** to the instrument, remove its top cover and lay the rear panel open for access to the Multidrop/LVDS PCA, which is seated on the CPU.
2. On the Multidrop/LVDS PCA's JP2 connector, remove the shunt that jumpers Pins 21 ↔ 22 as indicated in. (Do this for all but the last instrument in the chain where the shunt should remain at Pins 21 ↔ 22).
3. Check that the following cable connections are made in *all* instruments (again refer to Figure 3-16):
 - J3 on the Multidrop/LVDS PCA to the CPU's COM1 connector
(Note that the CPU's COM2 connector is not used in Multidrop)
 - J4 on the Multidrop/LVDS PCA to J12 on the motherboard
 - J1 on the Multidrop/LVDS PCS to the front panel LCD

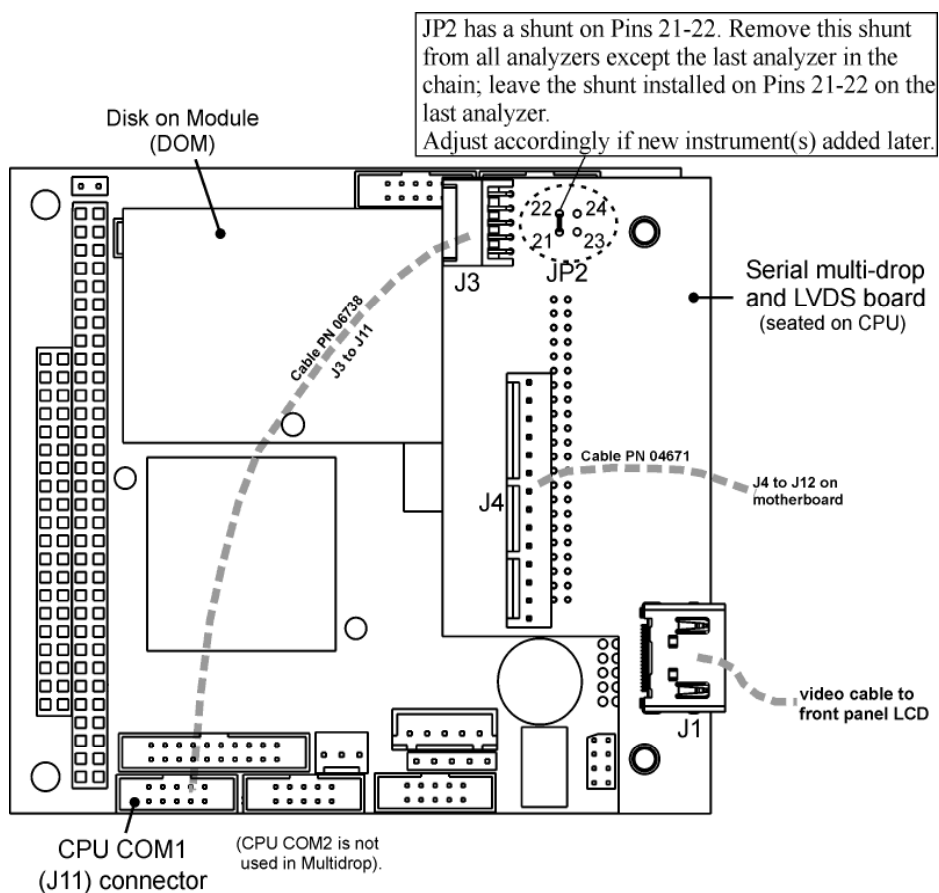

Figure 3-16: Jumper and Cables for Multidrop Mode

Note: If you are adding an instrument to the end of a previously configured chain, remove the shunt between Pins 21 ↔ 22 of JP2 on the Multidrop/LVDS PCA in the instrument that was previously the last instrument in the chain.

4. Close the instrument.
5. Referring to Figure 3-17 use straight-through DB9 male → DB9 female cables to interconnect the host RS232 port to the first analyzer's RS232 port; then from the first analyzer's COM2 port to the second analyzer's RS232 port; from the second analyzer's COM2 port to the third analyzer's RS232 port, etc., connecting in this fashion up to eight analyzers, subject to the distance limitations of the RS-232 standard.
6. On the rear panel of each analyzer, adjust the DCE DTE switch so that the green and the red LEDs (RX and TX) of the COM1 connector (labeled RS232) are both lit. (Ensure you are using the correct RS-232 cables internally wired specifically for RS-232 communication; see Table 1-1: Analyzer Options, "Communication Cables" and Section 3.3.1.9: Connecting the Communications Interfaces, "RS-232 Connection").

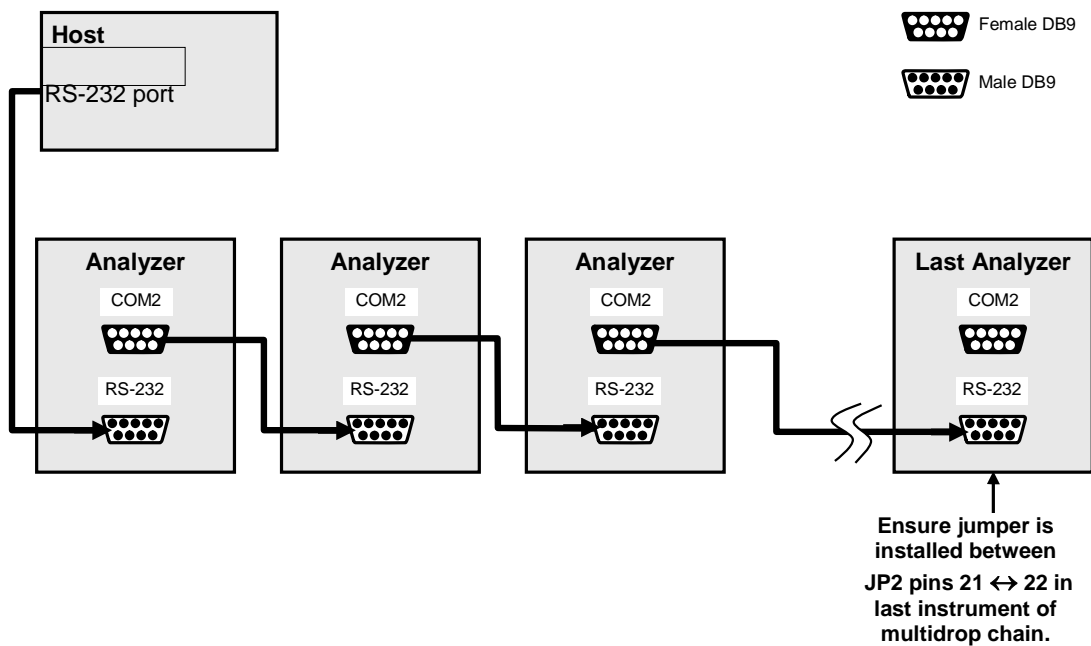

Figure 3-17: RS-232-Multidrop PCA Host/Analyzer Interconnect Diagram

7. BEFORE communicating from the host, power on the instruments and check that the Machine ID code is unique for each (Section 5.6.2).
 - a. In the SETUP Mode menu go to SETUP>MORE>COMM>ID. The default ID is typically the model number or “0”.
 - b. to change the identification number, press the button below the digit to be changed.
 - c. Press/select ENTER to accept the new ID for that instrument.
8. Next, in the SETUP>MORE>COMM>COM1 menu (do not use the COM2 menu for multidrop), edit the COM1 MODE parameter as follows: press/select EDIT and set only QUIET MODE, COMPUTER MODE, and MULTIDROP MODE to ON. Do not change any other settings.
9. Press/select ENTER to accept the changed settings, and ensure that COM1 MODE now shows 35.
10. Press/select SET> to go to the COM1 BAUD RATE menu and ensure it reads the same for all instruments (edit as needed so that all instruments are set at the same baud rate).

Note

The Instrument ID's should not be duplicated.

The (communication) Host instrument can only address one instrument at a time.

Note

TAI recommends setting up the first link, between the Host and the first analyzer, and testing it before setting up the rest of the chain.

RS-485 CONNECTION

As delivered from the factory, **COM2** is configured for RS-232 communications. This port can be reconfigured for operation as a non-isolated, half-duplex RS-485 port. Using COM2 for RS-485 communication disables the USB port. To configure the instrument for RS-485 communication, please contact the factory.

3.3.2. PNEUMATIC CONNECTIONS

This section provides not only pneumatic connection information, but also important information about the gases required for accurate calibration; it also illustrates the pneumatic layouts for the analyzer in its basic configuration and with options.

Before making the pneumatic connections, carefully note the following cautionary and special messages:



CAUTION
GENERAL SAFETY HAZARD
NITROUS OXIDE (N₂O)

APHYXIATION HAZARD. Do not vent calibration gas and sample gas into enclosed areas. Obtain a Material Safety Data Sheet (MSDS) for this material. Read and rigorously follow the safety guidelines described there.



CAUTION
GENERAL SAFETY HAZARD

Sample and calibration gases should only come into contact with PTFE (Teflon), FEP, glass, stainless steel or brass.

It is important to conform to all safety requirements regarding exposure to N₂O.

ATTENTION**-----
COULD DAMAGE INSTRUMENT AND VOID WARRANTY****Maximum Pressure:**

Ideally the maximum pressure of any gas at the sample inlet should equal ambient atmospheric pressure and should NEVER exceed 1.5 in-hg above ambient pressure.

Venting Pressurized Gas:

In applications where any gas (span gas, zero air supply, sample gas is) received from a pressurized manifold, a vent must be provided to equalize the gas with ambient atmospheric pressure before it enters the analyzer to ensure that the gases input do not exceed the maximum inlet pressure of the analyzer, as well as to prevent back diffusion and pressure effects. These vents should be:

- at least 0.2m long
- no more than 2m long
- vented outside the shelter or immediate area surrounding the instrument.

Dust Plugs:

Remove dust plugs from rear panel exhaust and supply line fittings before powering on/operating instrument. These plugs should be kept for reuse in the event of future storage or shipping to prevent debris from entering the pneumatics.

IMPORTANT**-----
Leak Check**

Run a leak check once the appropriate pneumatic connections have been made; check all pneumatic fittings for leaks using the procedures defined in Section 10.3.2.

See Figure 3-4 and Table 3-3 for the location and descriptions of the various pneumatic inlets/outlets referenced in this section.

Note: Depending on the application, some instruments may include an internal pump. Refer to any addendum that may accompany this manual for information pertaining to custom configurations.

3.3.2.1. PNEUMATIC CONNECTIONS FOR BASIC CONFIGURATION

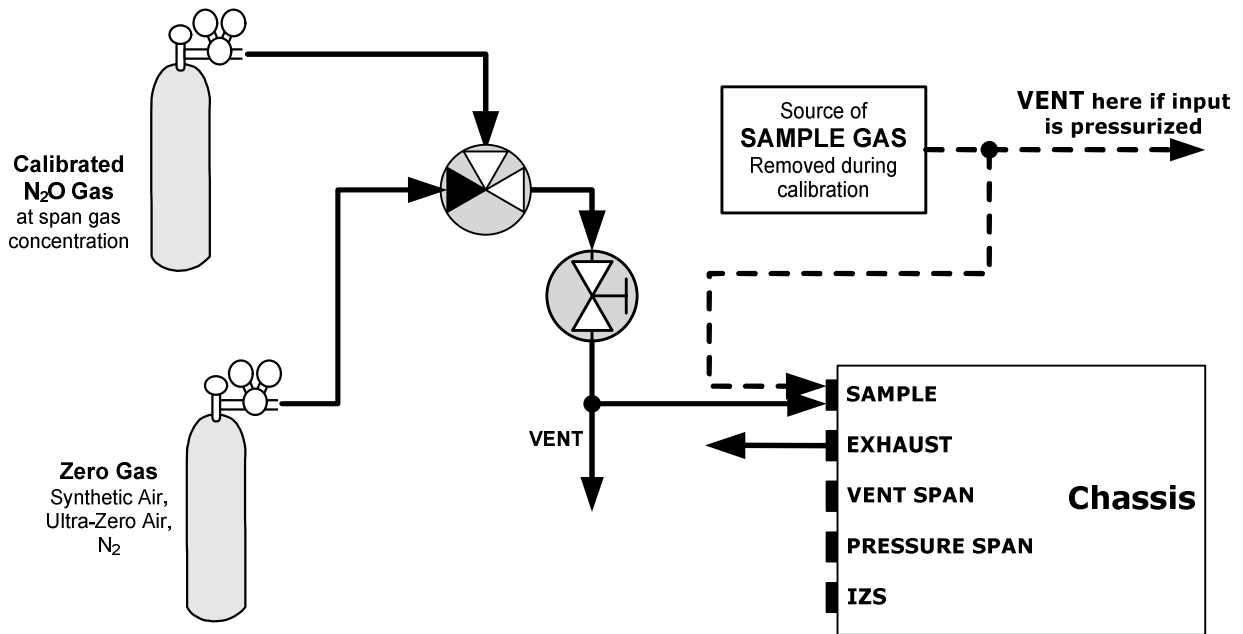

Figure 3-18: Pneumatic Connections–Basic Configuration–Using Bottled Span Gas

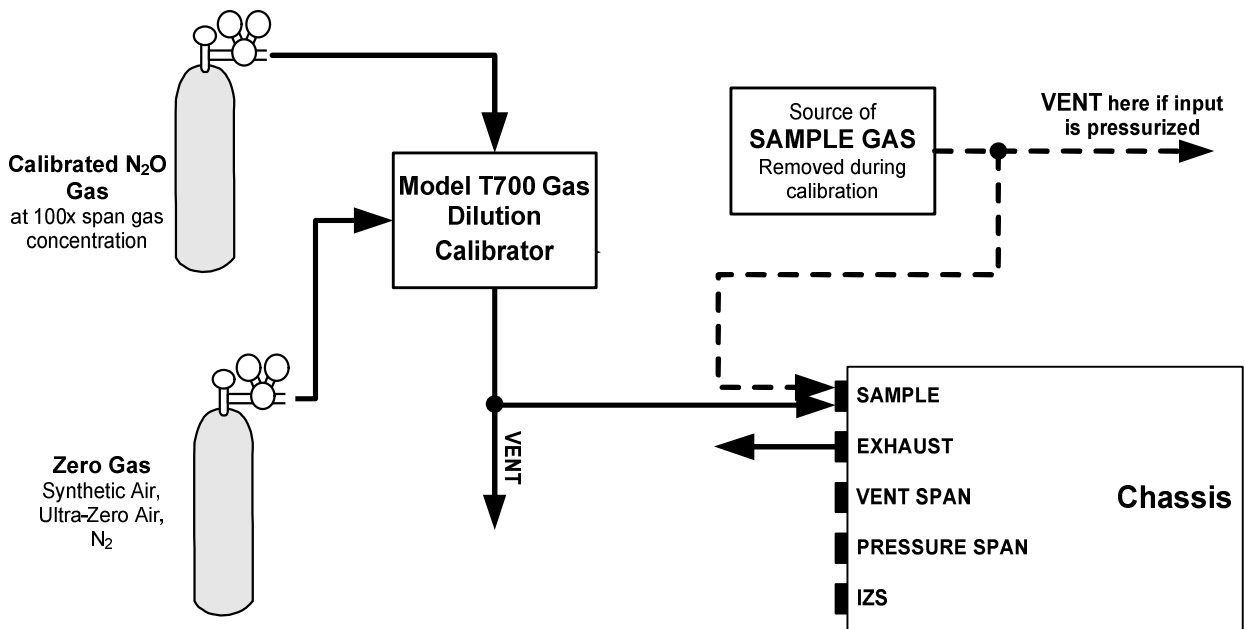

Figure 3-19: Pneumatic Connections–Basic Configuration–Using Gas Dilution Calibrator

SAMPLE GAS SOURCE

Attach a sample inlet line to the **SAMPLE** inlet port. The sample input line should not be more than 2 meters long.

- Maximum pressure of any gas at the sample inlet should not exceed 1.5 in-hg above ambient pressure and ideally should equal ambient atmospheric pressure.
- In applications where the sample gas is received from a pressurized manifold, a vent must be placed on the sample gas before it enters the analyzer.

CALIBRATION GAS SOURCES

The source of calibration gas is also attached to the **SAMPLE** inlet, but only when a calibration operation is actually being performed. The calibration gases should be available to the analyzer at the same pressure as the sample gas and with the same flow rate (800 cm³/min).

EXHAUST OUTLET

Attach an exhaust line to the analyzer's **EXHAUST** outlet fitting. The exhaust line should be:

- PTEF tubing; minimum O.D 1/4";
- A maximum of 10 meters long;
- Vented outside the GFC7002T/GFC7002TU Analyzer's enclosure.

3.3.2.2. PNEUMATIC LAYOUT FOR BASIC CONFIGURATION

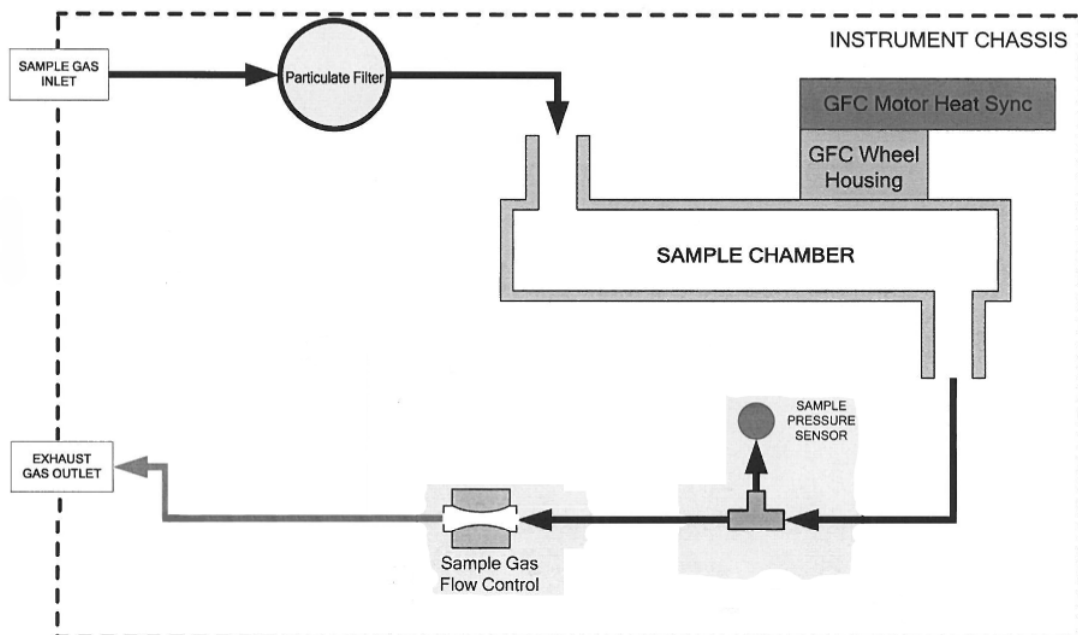

Figure 3-20: GFC7002T/GFC7002TU Internal Gas Flow

3.3.2.3. PNEUMATIC CONNECTIONS FOR ZERO/SPAN VALVE OPTION

The following figures show the pneumatic set up for GFC7002T/GFC7002TU analyzers with one of the three available internal valve options installed.

See Figure 3-4 for the location of gas inlets.

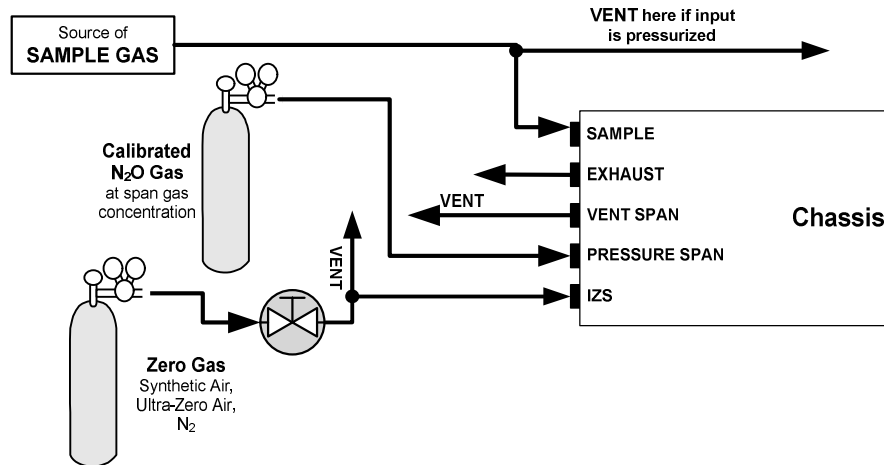

Figure 3-21: Pneumatic Connections – Option Z/S Valve with Shutoff Valve for Pressurized Span and Atmospheric Zero

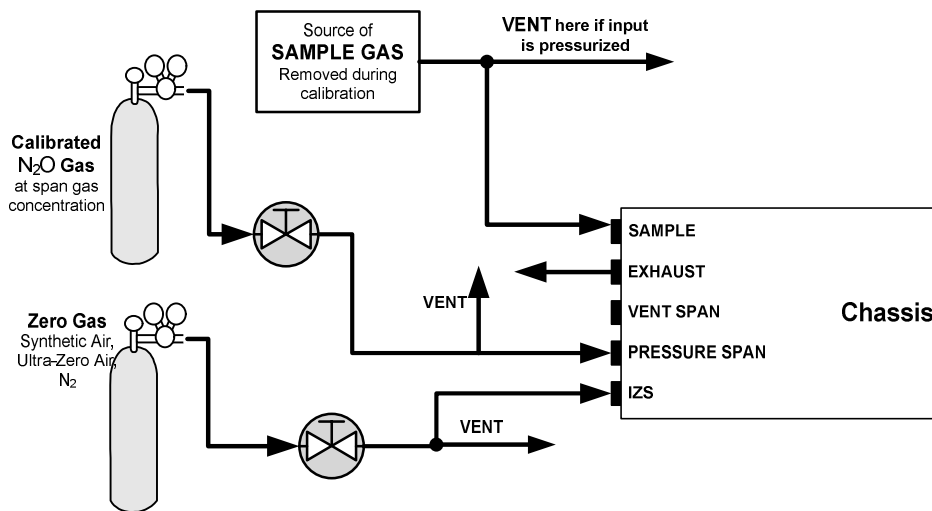

Figure 3-22. Pneumatics: Option Z/S without Shutoff Valve

SAMPLE GAS SOURCE

Attach a sample inlet line to the sample inlet port. The SAMPLE input line should not be more than 2 meters long.

- Maximum pressure of any gas at the sample inlet should not exceed 1.5 in-hg above ambient pressure and ideally should equal ambient atmospheric pressure.

- Flow rate should meet the demand of the instrument (800 cm³/min).

CALIBRATION GAS SOURCES

SPAN GAS:

Span gas is specifically mixed to match the chemical composition of the type of gas being measured at near full scale of the desired measurement range. In this case, N₂O measurements made with the GFC7002T/GFC7002TU analyzer, it is recommended that you use a span gas with a N₂O concentration equal to 80% of the measurement range for your application.

EXAMPLE: If the application is to measure between 0 ppm and 500 ppm, an appropriate span gas concentration would be 400 ppm N₂O in N₂.

Some applications require a multipoint calibration procedure where span gases of different concentrations are applied to the analyzer under test. We recommend using a bottle of calibrated N₂O gas of higher concentration in conjunction with a gas dilution calibrator such as a Teledyne Instruments Model T700. This type of calibrator precisely mixes a high concentration gas from with zero gas (both supplied externally as either synthetic air or N₂) to accurately produce span gas of the correct concentration. Linearity profiles can be automated with this model and run unattended over night.

Currently there are no Standard Reference Material (SRM) N₂O gases available off-the-shelf from NIST (National Institute of Standards and Technology) therefore it is essential that span gas be purchased from a reputable supplier and that the gas be traceable to a reputable national standards laboratory.

ZERO GAS:

Zero gas is similar in chemical composition to the atmosphere that is to be measured but scrubbed of all components that might affect the analyzers readings, in this case N₂O and water vapor. For the GFC7002T/GFC7002TU this gas **MUST** be synthetic air, ultra zero air or nitrogen (N₂).

NOTE

Zero air created by a Zero Air Generator like the TAI Model T701 should not be used since the T701 does not scrub N₂O. Likewise since there are no effective and convenient catalytic, absorptive or reactive scrubbers for N₂O, TAI does not offer a zero scrubber cartridge.

INLET PRESSURE RATING/CONSIDERATION

This instrument has no significant internal restriction other than the flow control device and pressure sensor shown in Figure 3-20. Sample must be introduced to the inlet fitting at a fraction of a PSI above ambient pressure, just enough to drive the flow to the proper value range. Depending on the ultimate sample or calibration gas source pressure, a needle valve, restrictor, critical orifice or combination there should be deployed to achieve this. Do not directly apply significant pressure to the inlet of the unit under any circumstances, as damage / and or personal injury may result.

EXHAUST OUTLET

Attach an exhaust line to the analyzer's EXHAUST outlet fitting. The exhaust line should be:

- PTEF tubing; minimum O.D 1/4"
- Maximum length of 10 meters
- Vented outside the analyzer's enclosure.

3.3.2.4. PNEUMATIC LAYOUT FOR ZERO/ SPAN VALVE OPTION

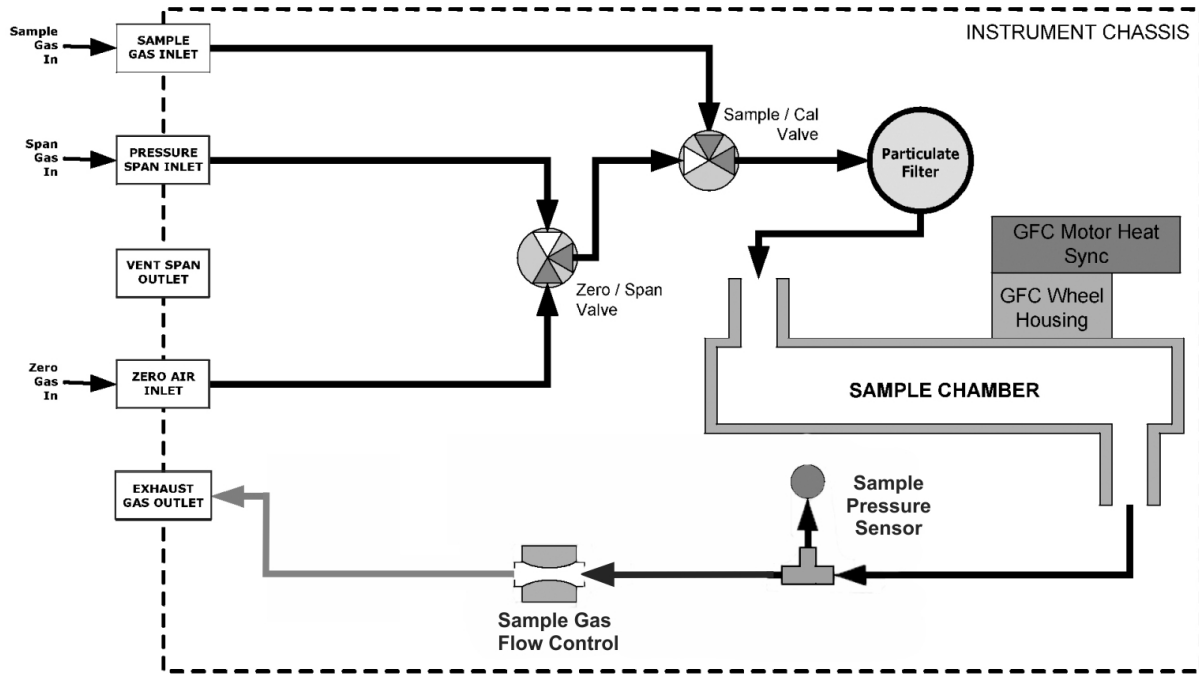

Figure 3-23 Internal Pneumatic Flow OPT 50A – Zero/ Span Valves

Table 3-8: Zero/ Span Valve Operating States for Option 50A

MODE	VALVE	CONDITION
SAMPLE (Normal State)	Sample/Cal	Open to SAMPLE inlet
	Zero/Span	Open to IZS inlet
ZERO CAL	Sample/Cal	Open to ZERO/SPAN valve
	Zero/Span	Open to IZS inlet
SPAN CAL	Sample/Cal	Open to ZERO/SPAN valve
	Zero/Span	Open to PRESSURE SPAN inlet

- PTFE tubing; minimum O.D 1/4"
- 10 meters long max.
- Vented outside the analyzer’s enclosure

3.3.2.5. PNEUMATIC LAYOUT FOR INTERNAL ZERO/ SPAN VALVE OPTION

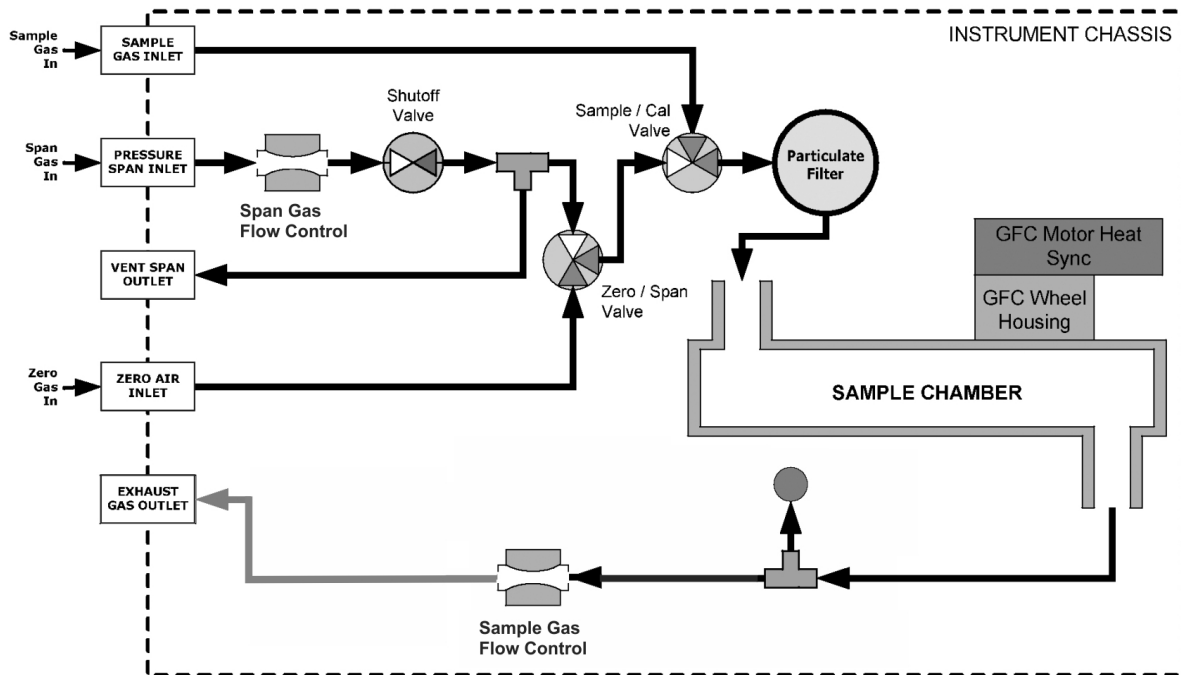

Figure 3-24: Internal Pneumatic Flow – Zero/Span/Shutoff Valves (Opt 50B)

Table 3-9: Zero/Span Valve Operating States for Option 50B

MODE	VALVE	CONDITION
SAMPLE (Normal State)	Sample/Cal	Open to SAMPLE inlet
	Zero/Span	Open to IZS inlet
	Shutoff Valve	Closed
ZERO CAL	Sample/Cal	Open to ZERO/SPAN valve
	Zero/Span	Open to IZS inlet
	Shutoff Valve	Closed
SPAN CAL	Sample/Cal	Open to ZERO/SPAN valve
	Zero/Span	Open to SHUTOFF valve
	Shutoff Valve	Open to PRESSURE SPAN Inlet

Table 3-10: Zero/Span Valve Operating States for Option 50E

Mode	Valve	Condition
SAMPLE (Normal State)	Sample/Cal	Open to SAMPLE inlet
	Zero/Span	Open to internal ZERO AIR scrubber
	Shutoff Valve	Closed
ZERO CAL	Sample/Cal	Open to zero/span valve
	Zero/Span	Open to internal ZERO AIR scrubber
	Shutoff Valve	Closed
SPAN CAL	Sample/Cal	Open to ZERO/SPAN valve
	Zero/Span	Open to SHUTOFF valve
	Shutoff Valve	Open to PRESSURE SPAN inlet

3.3.2.6. PNEUMATIC OPTION Z/S VALVE WITH PRESSURIZED ZERO AND SPAN

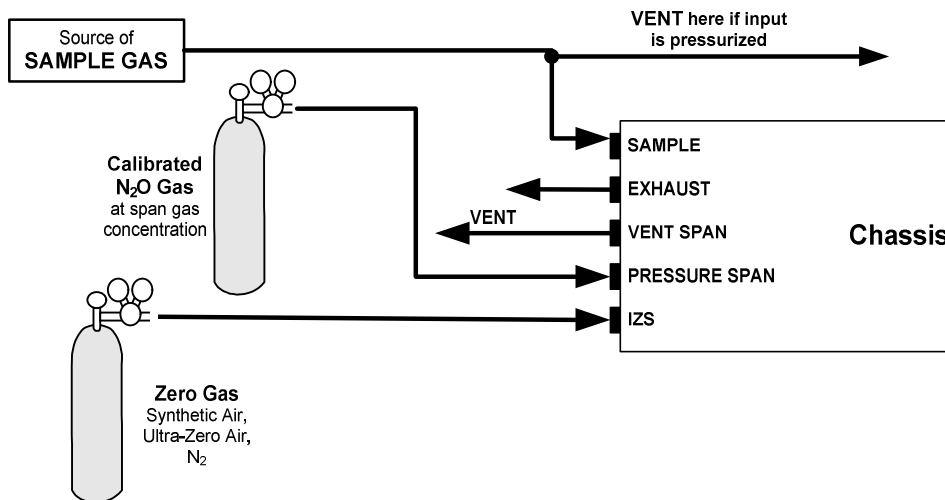

Figure 3-225. Pneumatics: Option Z/S Valve with Common Shutoff Valve for Pressurized Zero and Span

3.3.2.7. CALIBRATION GASES

Zero air and span gas are required for accurate calibration.

ZERO AIR

Zero air is a gas that is similar in chemical composition to the earth’s atmosphere but scrubbed of all components that might affect the analyzer’s readings, in this case N₂O

and water vapor. If your analyzer is equipped with an Internal Zero Span (IZS) or an external zero air scrubber option, it is capable of creating zero air.

If the analyzer is NOT equipped with the optional CO₂ sensor, zero air should be scrubbed of CO₂ as well, as this gas can also have an interfering effect on N₂O measurements.

For analyzers without an IZS or external zero air scrubber option, a zero air generator such as the TAI Model T701 can be used.

SPAN GAS

Span gas is specifically mixed to match the chemical composition of the type of gas being measured at near full scale of the desired measurement range. In this case, N₂O measurements made with the GFC7002T/GFC7002TU analyzer, it is recommended that you use a span gas with a N₂O concentration equal to 80% of the measurement range for your application.

EXAMPLE: If the application is to measure between 0 ppm and 500 ppm, an appropriate span gas concentration would be 400 ppm N₂O in N₂.

Some applications require a multipoint calibration procedure where span gases of different concentrations are applied to the analyzer under test. We recommend using a bottle of calibrated N₂O gas of higher concentration in conjunction with a gas dilution calibrator such as a Teledyne Instruments Model T700. This type of calibrator precisely mixes a high concentration gas from with zero gas (both supplied externally as either synthetic air or N₂) to accurately produce span gas of the correct concentration. Linearity profiles can be automated with this model and run unattended over night.

Currently there are no Standard Reference Material (SRM) N₂O gases available off-the-shelf from NIST (National Institute of Standards and Technology) therefore it is essential that span gas be purchased from a reputable supplier and that the gas be traceable to a reputable national standards laboratory.

SPAN GAS FOR MULTIPOINT CALIBRATION

Some applications, such as EPA monitoring, require a multipoint calibration procedure where span gases of different concentrations are needed. We recommend using a bottle of calibrated gas of higher concentration in conjunction with a gas dilution calibrator such as a TAI's T700. This type of calibrator precisely mixes a high concentration gas with zero air (both supplied externally) to accurately produce span gas of the correct concentration. Linearity profiles can be automated with this model and run unattended over night.

3.4. STARTUP, FUNCTIONAL CHECKS, AND INITIAL CALIBRATION

IMPORTANT

IMPACT ON READINGS OR DATA

The analyzer's cover must be installed to ensure that the temperatures of the GFC Wheel and absorption cell assemblies are properly controlled.

If you are unfamiliar with the GFC7002T/GFC7002TU theory of operation, we recommend that you read Section 12. For information on navigating the analyzer's software menus, see the menu trees described in Appendix A.

3.4.1. STARTUP

After the electrical and pneumatic connections are made, an initial functional check is in order. Turn on the instrument. The exhaust fan should start immediately. The display will briefly show a momentary splash screen of the TAI logo and other information during the initialization process while the CPU loads the operating system, the firmware and the configuration data at the start of initialization.

The analyzer should automatically switch to Sample Mode after completing the boot-up sequence and start monitoring the sample gas. However, there is an approximately one hour warm-up period before reliable gas measurements can be taken. During the warm-up period, the front panel display may show messages in the Parameters field.

3.4.2. WARNING MESSAGES

Because internal temperatures and other conditions may be outside the specified limits during the analyzer's warm-up period, the software will suppress most warning conditions for 30 minutes after power up. If warning messages persist after the 60 minutes warm-up period is over, investigate their cause using the troubleshooting guidelines in Section 11.

To view and clear warning messages, press:

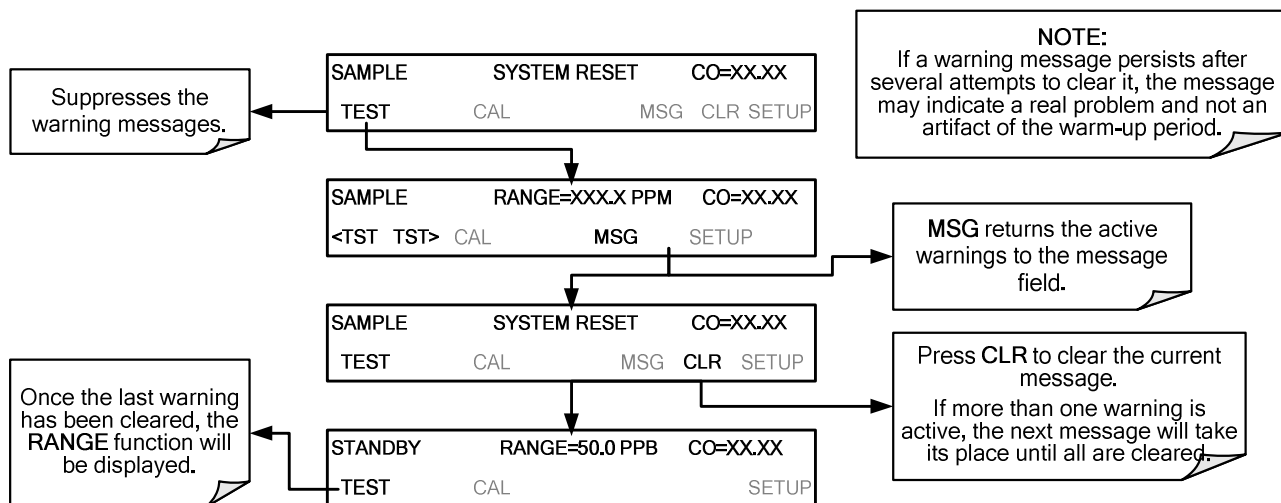

Note: The above screen(s) show CO concentration displayed. Your instrument will indicate and display N₂O concentration.

Table 3-11 lists brief descriptions of the warning messages that may occur during start up.

Table 3-11: Possible Warning Messages at Start-Up

Message	MEANING
ANALOG CAL WARNING	The instrument's A/D circuitry or one of its analog outputs is not calibrated.
BENCH TEMP WARNING	Optical bench temperature is outside the specified limits.
BOX TEMP WARNING	The temperature inside the GFC7002T/GFC7002TU chassis is outside the specified limits.
CANNOT DYN SPAN²	Remote span calibration failed while the dynamic span feature was set to turned on.
CANNOT DYN ZERO³	Remote zero calibration failed while the dynamic zero feature was set to turned on.
CONFIG INITIALIZED	Configuration was reset to factory defaults or was erased.
DATA INITIALIZED	DAS data storage was erased.
PHOTO TEMP WARNING	Photometer temperature outside of warning limits specified by PHOTO_TEMP_SET variable.
REAR BOARD NOT DET	Motherboard was not detected during power up.
RELAY BOARD WARN	CPU is unable to communicate with the relay PCA.
SAMPLE FLOW WARN	The flow rate of the sample gas is outside the specified limits.
SAMPLE PRESS WARN	Sample pressure outside of operational parameters.
SAMPLE TEMP WARN	The temperature of the sample gas is outside the specified limits.
SOURCE WARNING	The IR source may be faulty.
SYSTEM RESET¹	The computer was rebooted.
WHEEL TEMP WARNING	The Gas Filter Correlation Wheel temperature is outside the specified limits.
¹	Typically clears 45 minutes after power up.
²	Clears the next time successful zero calibration is performed.
³	Clears the next time successful span calibration is performed.

Table 3-12 lists brief descriptions of the warning messages that may occur during start up for GFC7002T analyzers with optional second gas options or alarms installed.

Table 3-12: Possible Startup Warning Messages – GFC7002T Analyzers with Options

Message	Meaning
O2 CELL TEMP WARN ¹	O ₂ sensor cell temperature outside of warning limits specified by O2_CELL_SET variable.
IZS TEMP WARNING ²	On units with IZS options installed: The permeation tube temperature is outside of specified limits.
O2 ALARM 1 WARN ^{1,4}	O ₂ Alarm limit #1 has been triggered. ⁴
O2 ALARM 2 WARN ^{1,4}	O ₂ Alarm limit #2 has been triggered. ⁴
CO2 ALARM 1 WARN ^{3,4}	CO ₂ Alarm limit #1 has been triggered. ⁴
CO2 ALARM 2 WARN ^{3,4}	CO ₂ Alarm limit #2 has been triggered. ⁴
SO2 ALARM1 WARN ⁴	SO ₂ Alarm limit #1 has been triggered. ⁴
SO2 ALARM2 WARN ⁴	SO ₂ Alarm limit #2 has been triggered. ⁴
¹ Only appears when the optional O ₂ sensor is installed. ² Only appears when the optional internal zero span (IZS) option is installed. ³ Only appears when the optional CO ₂ sensor is installed. ⁴ Only Appears when the optional gas concentration alarms are installed	

3.4.3. FUNCTIONAL CHECKS

After the analyzer's components have warmed up for at least 60 minutes, verify that the software properly supports any hardware options that were installed: navigate through the analyzer's software menus, see the menu trees described in Appendix A.

Then check to make sure that the analyzer is functioning within allowable operating parameters:

- Appendix C includes a list of test functions viewable from the analyzer's front panel as well as their expected values.
- These functions are also useful tools for diagnosing performance problems with your analyzer (see Section 11.1.2).
- The enclosed Final Test and Validation Data Sheet (P/N 04271) lists these values as they were before the instrument left the factory.

To view the current values of these parameters press the following control button sequence on the analyzer's front panel. Remember that until the unit has completed its warm-up these parameters may not have stabilized.

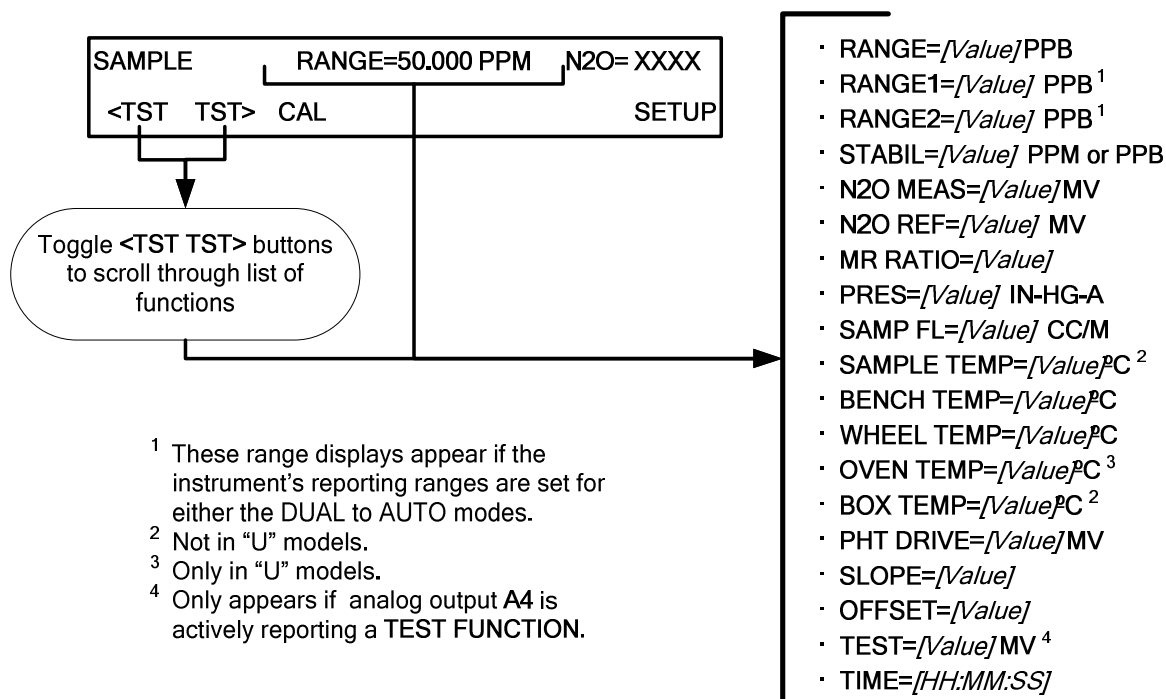

3.4.4. INITIAL CALIBRATION

To perform the following calibration you must have sources for zero air and span gas available for input into the sample port on the back of the analyzer. See Section 3.3.2 for instructions for connecting these gas sources.

The initial calibration should be carried out using the same reporting range set up as used during the analyzer's factory calibration. This will allow you to compare your calibration results to the factory calibration as listed on the *Final Test and Validation Data Sheet*.

If both available DAS parameters for a specific gas type are being reported via the instruments analog outputs e.g. **CONC1** and **CONC2** when the **DUAL** range mode is activated, separate calibrations should be carried out for each parameter.

- Use the **LOW** button when calibrating for **CONC1** (equivalent to **RANGE1**).
- Use the **HIGH** button when calibrating for **CONC2** (equivalent to **RANGE2**).

NOTE

The following procedure assumes that the instrument does not have any of the available Valve Options installed. See Section 0 for instructions for calibrating instruments that have valve options.

3.4.4.1. INTERFERENTS FOR N₂O MEASUREMENTS

It should be noted that the gas filter correlation method for detecting N₂O is subject to interference from a number of other gases that absorb IR in a similar fashion to N₂O. The GFC7002T/GFC7002TU has been successfully tested for its ability to reject interference from many interferents however high concentrations of these gases can interfere with the instrument's ability to make low-level N₂O measurements.

For a more detailed discussion of this topic, see Section 12.2.1.3.

The following table represents common interferences to the N₂O measurement. The interferent is followed by a column which gives the interference level in ppm N₂O (displayed) per ppm interferent. For example, 1 ppm silane in the analyzed gas would read on the display as 1.78 ppm N₂O and so forth.

#	Chemical	"N ₂ O" ppm/ppm
1	Silane	1.783268326
2	Allyl isothiocyanate	1.502622433
3	Arsine	1.18602091
4	2,4-Diisocyanatetoluene	1.168351821
5	Nitrous oxide	1
6	Carbon monoxide	0.838955031
7	Methyl isothiocyanate	0.461857545
8	n-Butyl isocyanate	0.315635503
9	Tetrafluoromethane	0.306408707
10	Germane	0.213603634
11	Carbon disulfide	0.172327989
12	Chlorosulfonyl isocyanate (CSI)	0.145078223
13	Methyl isocyanate (MIC)	0.078047978
14	Carbonyl fluoride	0.069584068
15	Formic acid (and some dimer)	0.059464725
16	Difluoromethane (R-32)	0.05867728
17	Cyanogen chloride	0.052950753
18	Dichlorosilane	0.049638785
19	Freon-C318 (octafluorocyclobutane)	0.046925103
20	Dimethyl carbonate	0.043930401
21	Hexafluorobenzene	0.041517395
22	Bromochlorodifluoromethane (Freon-12B1)	0.041200864
23	Dimethyl sulfoxide	0.03794731
24	tert-Butyl methyl ether	0.037497707
25	Ethylvinyl ether (EVE)	0.033826317
26	Dimethylcarbamoyl chloride	0.033599441
27	2-Chloro-1,1,1,2-tetrafluoroethane (HCFC-124)	0.032460735
28	tert-Amyl methyl ether	0.03234364
29	Trifluoroacetic anhydride	0.029777656
30	Dipropylene glycol methyl ether	0.029225934
31	1,1,1-Trifluoroethane (R143A)	0.027522041
32	trans-Crotonaldehyde	0.027180383
33	Difluorodibromomethane (Freon-12B2)	0.025606098
34	Freon-12 (Dichlorodifluoromethane)	0.02510076
35	Cyclohexane	0.025062499
36	Methyl salicylate	0.022519276
37	Trifluoroacetyl chloride	0.021837366

38	Freon-134a (1,1,1,2-tetrafluoroethane)	0.020079881
39	1,1-Difluoro-2,2-dichloroethane (R132A)	0.019180967
40	1,2-Difluorotetrachloroethane (R112)	0.018992111
41	2-Chloro-1,1,1-trifluoroethane (R133A)	0.018928924
42	Diisopropyl ether	0.018465398
43	Chlorodifluoromethane (F22)	0.017218627
44	2-Butoxyethanol	0.017141505
45	1,2-Dimethoxyethane	0.016631247
46	Hexamethylphosphoramide	0.015800985
47	Phosphine	0.015677466
48	Ethyl tert-butyl ether	0.015557678
49	Nicotine	0.015379242
50	Propylenimine	0.014894811

3.4.4.2. INITIAL CALIBRATION PROCEDURE

The following procedure assumes that:

- The instrument DOES NOT have any of the available calibration valve or gas inlet options installed;
- Cal gas will be supplied through the SAMPLE gas inlet on the back of the analyzer (see Figure 3-4)

*Note: Zero gas is similar in chemical composition to the atmosphere that is to be measured but scrubbed of all components that might affect the analyzers readings, in this case N₂O and water vapor. For the GFC7002T/GFC7002TU this gas **MUST** be synthetic air, ultra zero air or nitrogen (N₂). The pneumatic setup matches that described in Section 3.3.2.1.*

VERIFYING THE GFC7002T/GFC7002TU REPORTING RANGE SETTINGS

While it is possible to perform the following procedure with any range setting we recommend that you perform this initial checkout using following reporting range settings:

- Unit of Measure: PPM
- Analog Output Reporting Range: 50 ppm
- Mode Setting: SNGL

While these are the default setting for the GFC7002T/GFC7002TU Analyzer, it is recommended that you verify them before proceeding with the calibration procedure, by pressing:

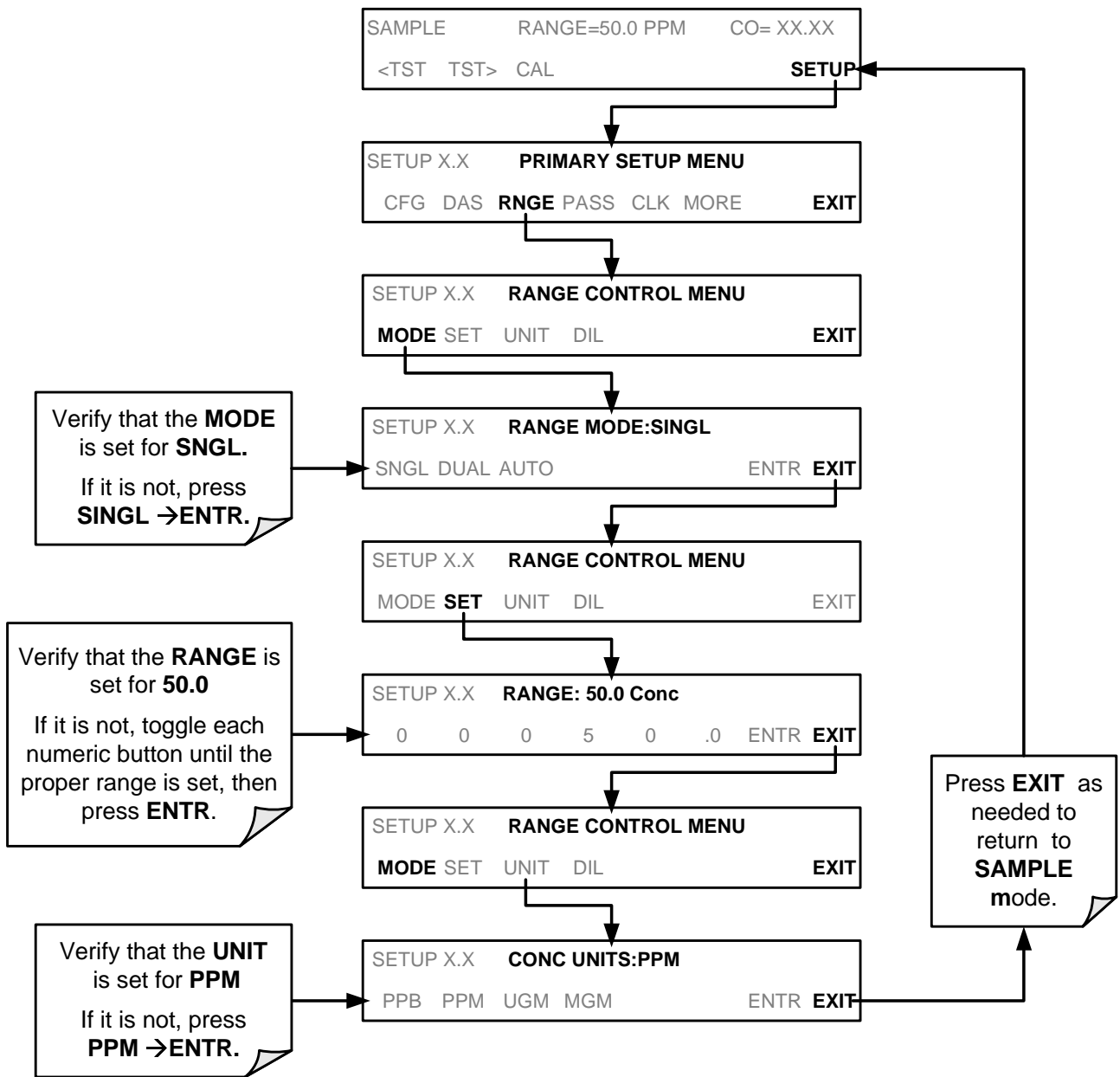

Note: The above screen(s) show CO concentration displayed. Your instrument will indicate and display N₂O concentration.

DILUTION RATIO SET UP

If the dilution ratio option is enabled on your GFC7002T/GFC7002TU Analyzer and your application involves diluting the sample gas before it enters the analyzer, set the dilution ratio as follows:

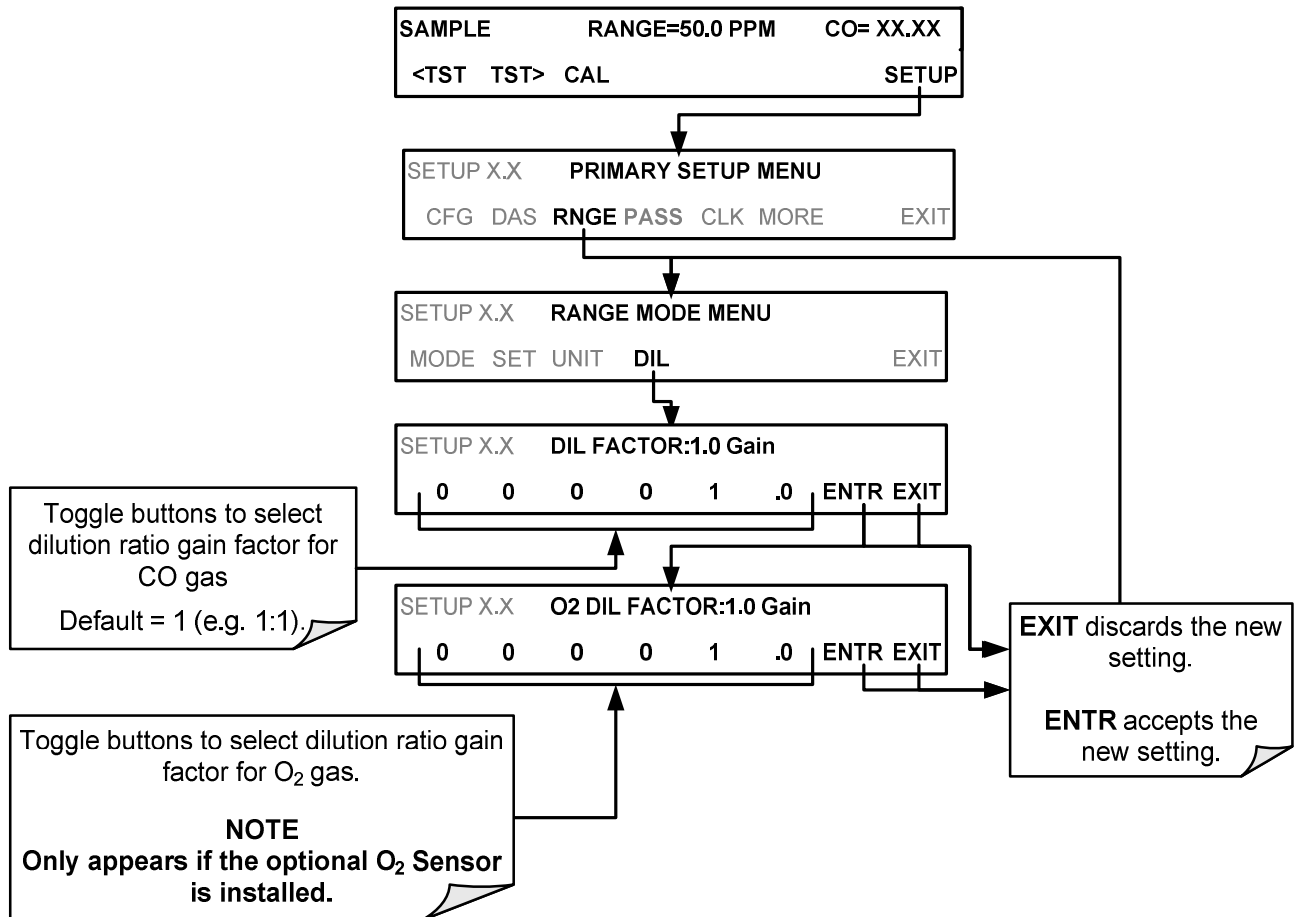

Note: The above screen(s) show CO concentration displayed. Your instrument will indicate and display N₂O concentration.

SET SPAN GAS CONCENTRATION

Set the expected N₂O span gas concentration. This should be 80% of range of concentration range for which the analyzer's analog output range is set.

EXAMPLE: If the application is to measure between 0 ppm and 500 ppm, an appropriate span gas concentration would be 400 ppm N₂O in N₂.

Some applications require a multipoint calibration procedure where span gases of different concentrations are applied to the analyzer under test. We recommend using a bottle of calibrated N₂O gas of higher concentration in conjunction with a gas dilution calibrator such as a Teledyne Instruments Model T700. This type of calibrator precisely mixes a high concentration gas from with zero gas (both supplied externally as either synthetic air or N₂) to accurately produce span gas of the correct concentration. Linearity profiles can be automated with this model and run unattended over night.

Currently there are no Standard Reference Material (SRM) N₂O gases available off-the-shelf from NIST (National Institute of Standards and Technology) therefore it is essential that span gas be purchased from a reputable supplier and that the gas be traceable to a reputable national standards laboratory.

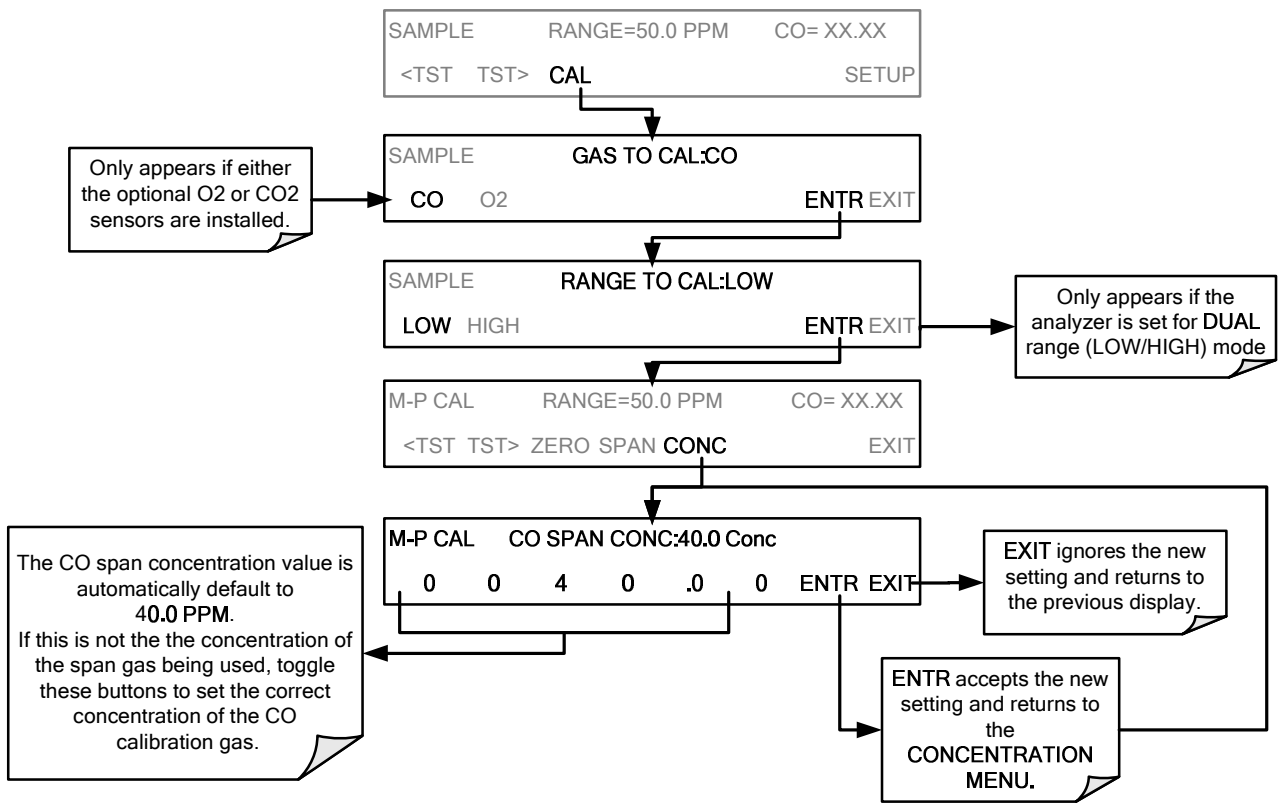

Note: The above screen(s) show CO concentration displayed. Your instrument will indicate and display N₂O concentration.

ZERO/SPAN CALIBRATION

To perform the zero/span calibration procedure, press:

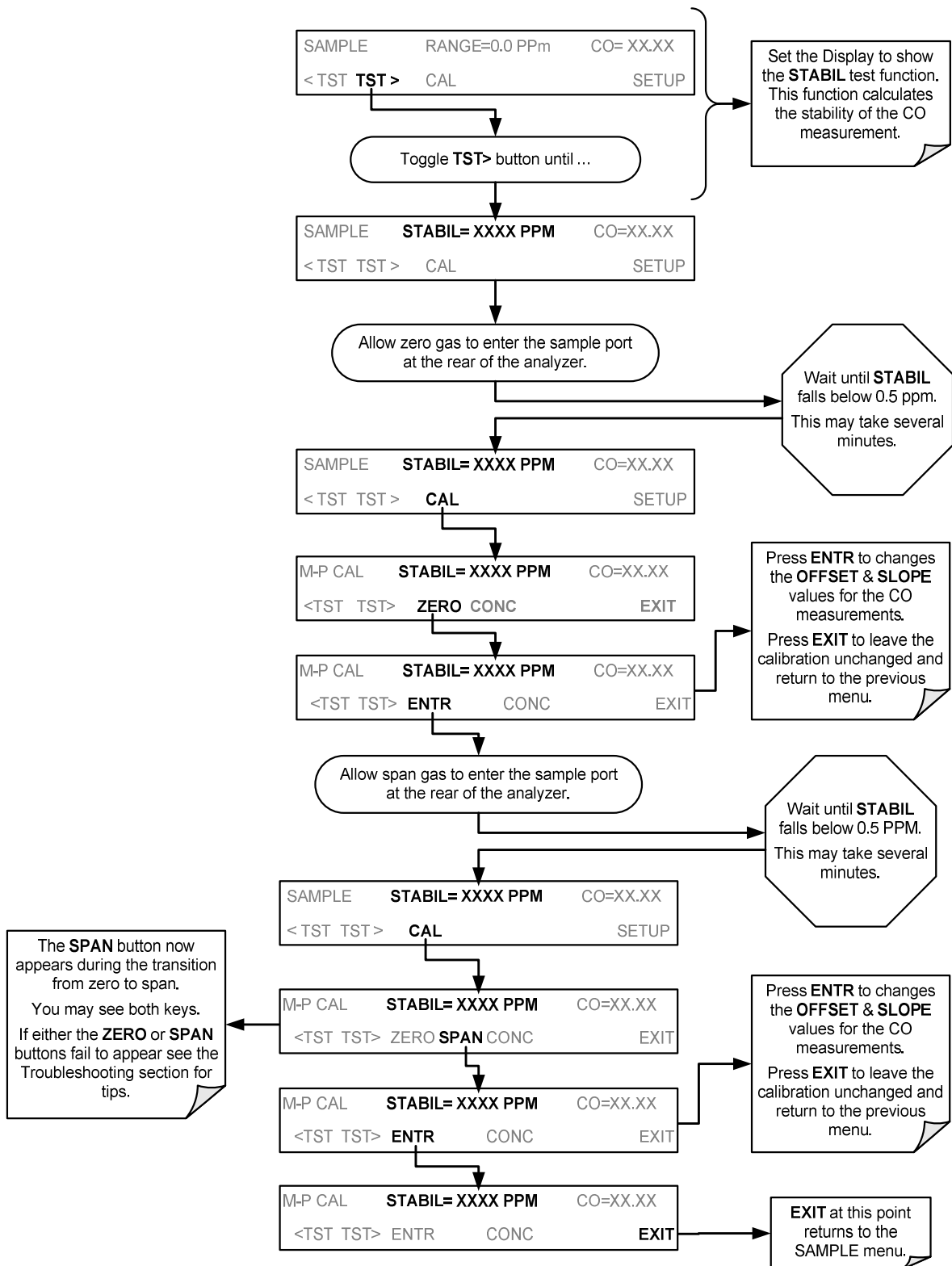

Figure 3-26: Zero/Span Calibration Procedure

Note: The above screen(s) show CO concentration displayed. Your instrument will indicate and display N₂O concentration.

3.4.4.3. O₂ SENSOR CALIBRATION PROCEDURE

If your GFC7002T/GFC7002TU is equipped with the optional O₂ sensor, this sensor should be calibrated during installation of the instrument. See Section 9.6.1 for instructions. Refer to any addenda that may accompany this instrument for custom configuration such as an optional O₂ sensor.

3.4.4.4. CO₂ SENSOR CALIBRATION PROCEDURE

If your GFC7002T/GFC7002TU is equipped with the optional CO₂ sensor, this sensor should be calibrated during installation of the instrument. See Section 0 for instructions. Refer to any addenda that may accompany this instrument for custom configuration such as an optional CO₂ sensor.

Note

Once you have completed the above set-up procedures, please fill out the Quality Questionnaire that was shipped with your unit and return it to TAI. This information is vital to our efforts in continuously improving our service and our products. THANK YOU.

PART II
OPERATING INSTRUCTIONS

This page intentionally left blank.

4. OVERVIEW OF OPERATING MODES

To assist in navigating the analyzer's software, a series of menu trees can be found in Appendix A of this manual.

Note

Some control buttons on the touch screen do not appear if they are not applicable to the menu that you're in, the task that you are performing, the command you are attempting to send, or to incorrect settings input by the user. For example, the ENTR button may disappear if you input a setting that is invalid or out of the allowable range for that parameter, such as trying to set the 24-hour clock to 25:00:00. Once you adjust the setting to an allowable value, the ENTR button will re-appear.

The GFC7002T/GFC7002TU software has a variety of operating modes. Most commonly, the analyzer will be operating in **Sample Mode**. In this mode a continuous read-out of the N₂O concentration can be viewed on the front panel and output as an analog voltage from rear panel terminals, calibrations can be performed and TEST functions and WARNING messages can be examined. If the analyzer is configured to measure a second gas (e.g. N₂O along with O₂ or CO₂) the display will show a readout of both concentrations.

The second most important operating mode is SETUP mode. This mode is used for performing certain configuration operations, such as for the DAS system, the reporting ranges, or the serial (RS 232 / RS 485 / Ethernet) communication channels. The SETUP mode is also used for performing various diagnostic tests during troubleshooting.

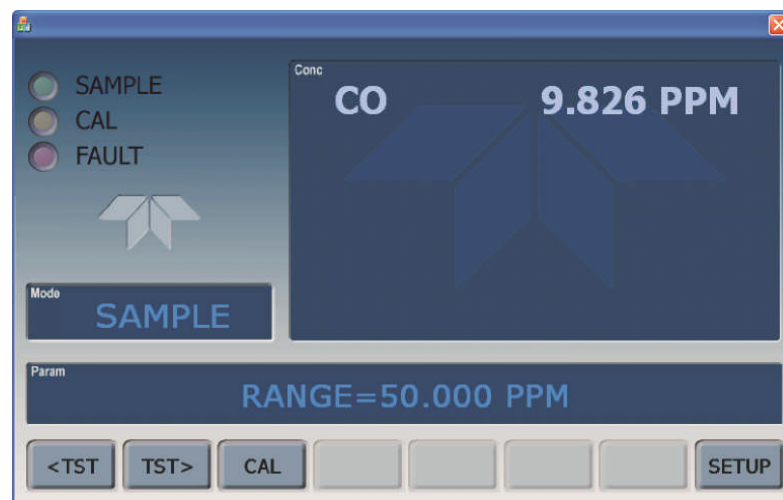

Figure 4-1: Front Panel Display

Note: The screen shots taken for this section were obtained from a CO analyzer. All screens on the GFC7002T/GFC7002TU units are identical but indicate N₂O rather than CO. Your instrument will indicate and display N₂O concentration.

The mode field of the front panel display indicates to the user which operating mode the unit is currently running.

Besides **SAMPLE** and **SETUP**, other modes the analyzer can be operated in are:

Table 4-1: Analyzer Operating Modes

MODE	EXPLANATION
DIAG	One of the analyzer's diagnostic modes is active (refer to Section 5.8).
LO CAL A	Unit is performing LOW SPAN (midpoint) calibration initiated automatically by the analyzer's AUTOCAL feature
LO CAL R	Unit is performing LOW SPAN (midpoint) calibration initiated remotely through the COM ports or digital control inputs.
M-P CAL	This is the basic calibration mode of the instrument and is activated by pressing the CAL button.
SAMPLE	Sampling normally, flashing text indicates adaptive filter is on.
SAMPLE A	Indicates that unit is in SAMPLE mode and AUTOCAL feature is activated.
SETUP X.#²	SETUP mode is being used to configure the analyzer. The gas measurement will continue during this process.
SPAN CAL A¹	Unit is performing SPAN calibration initiated automatically by the analyzer's AUTOCAL feature
SPAN CAL M¹	Unit is performing SPAN calibration initiated manually by the user.
SPAN CAL R¹	Unit is performing SPAN calibration initiated remotely through the COM ports or digital control inputs.
ZERO CAL A¹	Unit is performing ZERO calibration procedure initiated automatically by the AUTOCAL feature
ZERO CAL M¹	Unit is performing ZERO calibration procedure initiated manually by the user.
ZERO CAL R¹	Unit is performing ZERO calibration procedure initiated remotely through the COM ports or digital control inputs.
¹ Only Appears on units with Z/S valve or IZS options.	
² The revision of the analyzer firmware is displayed following the word SETUP, e.g., SETUP G.3.	

4.1. SAMPLE MODE

This is the analyzer's standard operating mode. In this mode the instrument is analyzing the gas in the sample chamber, calculating N₂O concentration and reporting this information to the user via the front panel display, the analog outputs and, if set up properly, the RS-232/RS-485/Ethernet/USB ports.

4.1.1. TEST FUNCTIONS

A series of **TEST** functions is available for viewing at the front panel whenever the analyzer is at the **SAMPLE** mode. These parameters provide information about the present operating status of the instrument and are useful during troubleshooting (refer to Section 11.1.2). They can also be recorded in one of the DAS channels (refer to Section 7.2) for data analysis. To view the test functions, press one of the <TST TST> buttons repeatedly in either direction.

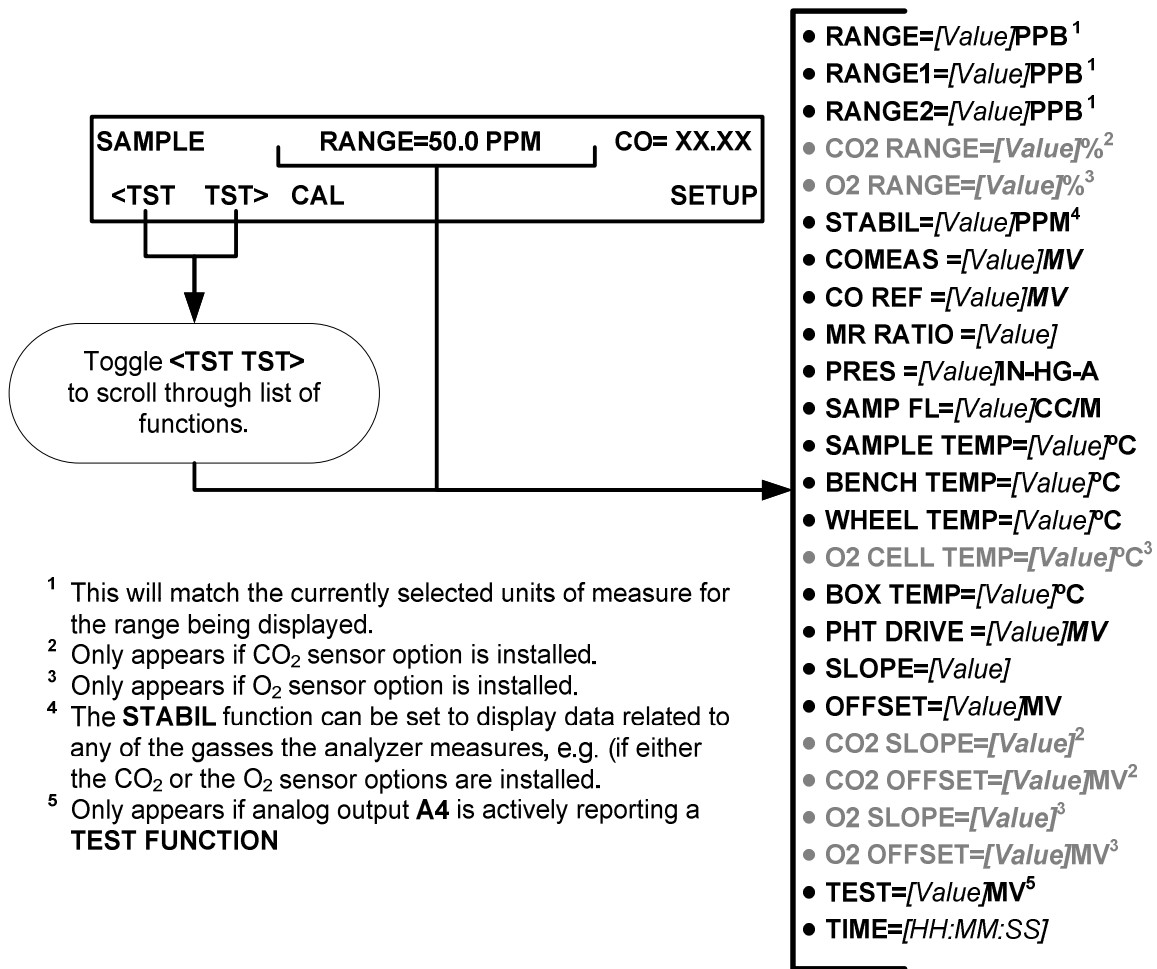

Figure 4-2: Viewing GFC7002T/GFC7002TU Test Functions

Note: The above screen(s) show CO concentration displayed. Your instrument will indicate and display N₂O concentration.

IMPORTANT

IMPACT ON READING OR DATA

A value of “XXXX” displayed for any of the TEST functions indicates an out-of-range reading or the analyzer’s inability to calculate it. All pressure measurements are represented in terms of absolute pressure. Absolute, atmospheric pressure is 29.92 in-Hg-A at sea level. It decreases about 1 in-Hg per 300 m gain in altitude. A variety of factors such as air conditioning and passing storms can cause changes in the absolute atmospheric pressure.

Table 4-2: Test Functions Defined

PARAMETER	DISPLAY TITLE	UNITS	MEANING
Stability	STABIL	PPB ³ , PPM UGM ³ , MGM	Standard deviation of N ₂ O concentration readings. Data points are recorded every ten seconds using the last 25 data points. This function can be reset to show O ₂ or CO ₂ stability in instruments with those sensor options installed.
Range	RANGE RANGE1¹ RANGE2¹	PPB, PPM, UGM, MGM	The full scale limit at which the reporting range of the analyzer is currently set. THIS IS NOT the Physical Range of the instrument. See Section 5.4.1 for more information.
O ₂ Range ¹	O₂ RANGE	%	The range setting for the optional O ₂ Sensor.
CO ₂ Range ²	CO₂ RANGE	%	The range setting for the optional CO ₂ Sensor.
N ₂ O Measure	N2OMEAS	MV	The demodulated, peak IR detector output during the measure portion of the GFC Wheel cycle.
N ₂ O Reference	N2O REF	MV	The demodulated, peak IR detector output during the reference portion of the GFC Wheel cycle.
Measurement / Reference Ratio	MR Ratio	-	The result of N2O MEAS divided by N2O REF . This ratio is the primary value used to compute N ₂ O concentration. The value displayed is not linearized.
Sample Pressure	PRES	In-Hg-A	The absolute pressure of the Sample gas as measured by a pressure sensor located inside the sample chamber.
Sample Flow	SAMPLE FL	cm ³ /min	Sample mass flow rate as measured by the flow rate sensor in the sample gas stream.
Sample Temperature	SAMP TEMP	°C	The temperature of the gas inside the sample chamber.
Bench Temperature	BENCH TEMP	°C	Optical bench temperature.
Wheel Temperature	WHEEL TEMP	°C	GFC Wheel temperature.
Box Temperature	BOX TEMP	°C	The temperature inside the analyzer chassis.
O ₂ Cell Temperature ¹	O₂ CELL TEMP³	°C	The current temperature of the O ₂ sensor measurement cell.
Photo-detector Temp. Control Voltage	PHT DRIVE	mV	The drive voltage being supplied to the thermoelectric coolers of the IR photo-detector by the sync/demod Board.
Slope	SLOPE	-	The sensitivity of the instrument as calculated during the last calibration activity.
Offset	OFFSET	-	The overall offset of the instrument as calculated during the last calibration activity.
O ₂ Sensor Slope ¹	O₂ SLOPE	-	O ₂ slope, computed during zero/span calibration.
O ₂ Sensor Offset ¹	O₂ OFFSET	-	O ₂ offset, computed during zero/span calibration.
CO ₂ Sensor Slope ²	CO₂ SLOPE	-	CO ₂ slope, computed during zero/span calibration.
CO ₂ Sensor Offset ²	CO₂ OFFSET	-	CO ₂ offset, computed during zero/span calibration.
Current Time	TIME	-	The current time. This is used to create a time stamp on DAS readings, and by the AUTOCAL feature to trigger calibration events.
¹ Only appears when the optional O ₂ sensor is installed. ² Only appears when the optional CO ₂ sensor is installed. ³ Only available on the GFC7002T.			

4.1.2. WARNING MESSAGES

The most common instrument failures will be reported as a warning on the analyzer's front panel and through the **COMM** ports. Section 11.1.1 explains how to use these messages to troubleshoot problems. Section 4.1.2 shows how to view and clear warning messages.

Table 4-3: List of Warning Messages

MESSAGE	MEANING
ANALOG CAL WARNING	The instrument's A/D circuitry or one of its analog outputs is not calibrated.
BENCH TEMP WARNING	The temperature of the optical bench is outside the specified limits.
BOX TEMP WARNING	The temperature inside the chassis is outside the specified limits.
CANNOT DYN SPAN²	Remote span calibration failed while the dynamic span feature was set to turned on.
CANNOT DYN ZERO³	Remote zero calibration failed while the dynamic zero feature was set to turned on.
CONC ALRM1 WARNING¹	Concentration alarm 1 is enabled and the measured N ₂ O level is ≥ the set point.
CONC ALRM2 WARNING¹	Concentration alarm 2 is enabled and the measured N ₂ O level is ≥ the set point.
CONFIG INITIALIZED	Configuration storage was reset to factory configuration or erased.
DATA INITIALIZED	DAS data storage was erased.
O₂ CELL TEMP WARN²	O ₂ sensor cell temperature outside of warning limits.
PHOTO TEMP WARNING	The temperature of the IR photo detector is outside the specified limits.
REAR BOARD NOT DET	The CPU is unable to communicate with the motherboard.
RELAY BOARD WARN	The firmware is unable to communicate with the relay board.
SAMPLE FLOW WARN	The flow rate of the sample gas is outside the specified limits.
SAMPLE PRESS WARN	Sample gas pressure outside of operational parameters.
SAMPLE TEMP WARN	The temperature of the sample gas is outside the specified limits.
SOURCE WARNING	The IR source may be faulty.
SYSTEM RESET¹	The computer was rebooted.
WHEEL TEMP WARNING	The Gas Filter Correlation Wheel temperature is outside the specified limits.

¹ Alarm warnings only present when optional alarm package is activated.
² Only enabled when the optional O₂ Sensor is installed.

To view and clear warning messages:

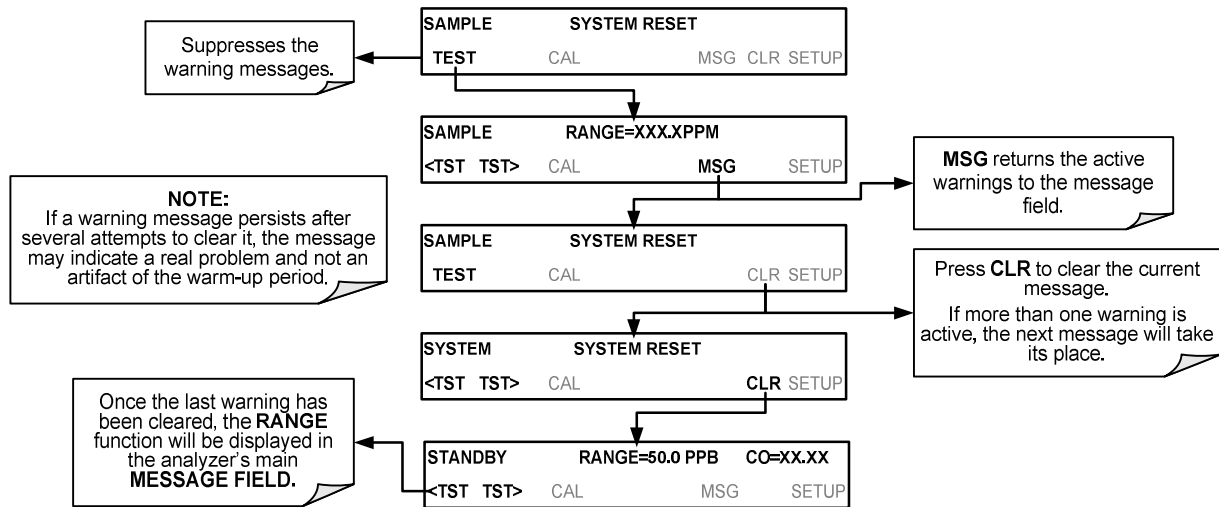

Figure 4-3: Viewing and Clearing GFC7002T/GFC7002TU WARNING Messages

Note: The above screen(s) show CO concentration displayed. Your instrument will indicate and display N₂O concentration.

4.2. CALIBRATION MODE

Pressing the CAL button switches the GFC7002T/GFC7002TU into calibration mode. In this mode the user can calibrate the instrument with the use of calibrated zero or span gases. This mode is also used to check the current calibration status of the instrument.

- For more information about setting up and performing standard calibration operations or checks, see Section 9.
- For more information about setting up and performing EPA equivalent calibrations, see Section **Error! Reference source not found.**
- If the instrument includes one of the available zero/span valve options, the **SAMPLE** mode display will also include **CALZ** and **CALS** buttons. Pressing either of these buttons also puts the instrument into calibration mode.
- The **CALZ** button is used to initiate a calibration of the analyzer’s zero point using internally generated zero air.
- The **CALS** button is used to calibrate the span point of the analyzer’s current reporting range using span gas.

For more information concerning calibration valve options, see Table 1-1.

For information on using the automatic calibration feature (**ACAL**) in conjunction with the one of the calibration valve options, see Section 9.3.

IMPORTANT

IMPACT ON READINGS OR DATA

It is recommended that this span calibration be performed at 80% of full scale of the analyzer’s currently selected reporting range. EXAMPLE: If the application is to measure between 0 ppm and 500 ppm, an appropriate span gas concentration would be 400 ppm N₂O in N₂.

4.3. SETUP MODE

The **SETUP** mode contains a variety of choices that are used to configure the analyzer's hardware and software features, perform diagnostic procedures, gather information on the instrument's performance, and configure or access data from the internal data acquisition system (DAS). For a visual representation of the software menu trees, refer to Appendix A.

Setup Mode is divided between Primary and Secondary Setup menus and can be protected through password security.

4.3.1. PASSWORD SECURITY

Setup Mode can be protected by password security through the **SETUP>PASS** menu (Section 5.5) to prevent unauthorized or inadvertent configuration adjustments.

4.3.2. PRIMARY SETUP MENU

The areas accessible under the **SETUP** mode are shown in Table 4-4 and Secondary Setup Menu (**SETUP>MORE**)

Table 4-5.

Table 4-4: Primary Setup Mode Features and Functions

MODE OR FEATURE	CONTROL BUTTON	DESCRIPTION	MANUAL SECTION
Analyzer Configuration	CFG	Lists button hardware and software configuration information	5
Auto Cal Feature	ACAL	Used to set up and operate the AutoCal feature. Only appears if the analyzer has one of the internal valve options installed.	5.2 and 9.3
Internal Data Acquisition (DAS)	DAS	Used to set up the DAS system and view recorded data	7
Analog Output Reporting Range Configuration	RNGE	Used to configure the output signals generated by the instruments Analog outputs.	0
Calibration Password Security	PASS	Turns the calibration password feature ON/OFF.	5.3
Internal Clock Configuration	CLK	Used to Set or adjust the instrument's internal clock.	5.6
Advanced SETUP features	MORE	This button accesses the instruments secondary setup menu.	See Table 6-5

4.3.3. SECONDARY SETUP MENU (SETUP>MORE)

Table 4-5: Secondary Setup Mode (SETUP>MORE) Features and Functions

MODE OR FEATURE	CONTROL BUTTON	DESCRIPTION	MANUAL SECTION
External Communication Channel Configuration	COMM	Used to set up and operate the analyzer's various serial channels including RS-232, RS-485, modem communication, Ethernet and/or USB.	0
System Status Variables	VAR	Used to view various variables related to the instrument's current operational status. <ul style="list-style-type: none"> Changes made to any variable are not recorded in the instrument's memory until the ENTR button is pressed. Pressing the EXIT button ignores the new setting. 	5.7
System Diagnostic Features and Analog Output Configuration	DIAG	Used to access a variety of functions that are used to configure, test or diagnose problems with a variety of the analyzer's basic systems. Most notably, the menus used to configure the output signals generated by the instrument's Analog outputs are located here.	5.8
Alarm Limit Configuration ¹	ALRM	Used to turn the instrument's two alarms on and off as well as set the trigger limits for each.	5.9

¹ Alarm warnings only present when optional alarm package is activated.

IMPORTANT

IMPACT ON READINGS OR DATA

Any changes made to a variable during the **SETUP** procedures are not acknowledged by the instrument until the **ENTR** button is pressed. If the **EXIT** button is pressed before the **ENTR** button, the analyzer will beep, alerting the user that the newly entered value has not been accepted.

5. SETUP MENU

The SETUP menu is used to set instrument parameters for performing configuration, calibration, reporting and diagnostics operations according to user needs.

5.1. SETUP → CFG: CONFIGURATION INFORMATION

Pressing the **CFG** button displays the instrument's configuration information. This display lists the analyzer model, serial number, firmware revision, software library revision, CPU type and other information.

- Special instrument or software features or installed options may also be listed here.
- Use this information to identify the software and hardware installed in your GFC7002T/GFC7002TU Analyzer when contacting customer service.

To access the configuration table, press:

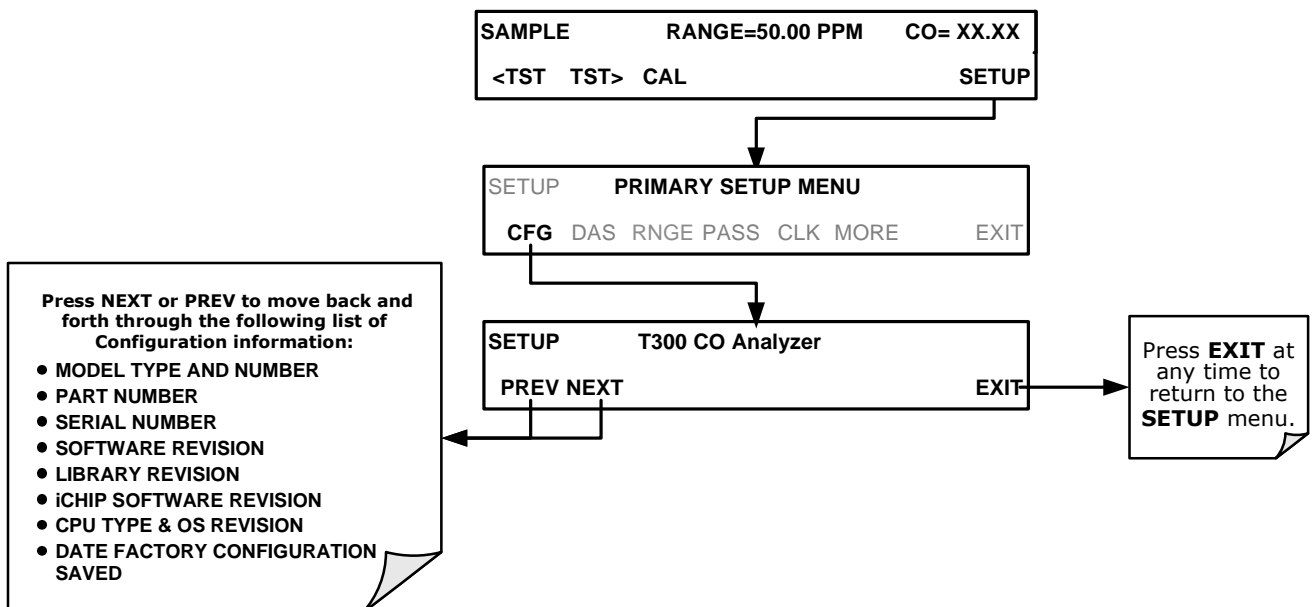

Note: The above screen(s) show CO concentration displayed. Your instrument will indicate and display N₂O concentration.

5.2. SETUP → ACAL: AUTOMATIC CALIBRATION

Instruments with one of the internal valve options installed can be set to automatically run calibration procedures and calibration checks. These automatic procedures are programmed using the submenus and functions found under the **ACAL** menu.

A menu tree showing the **ACAL** menu's entire structure can be found in Appendix A-1 of this manual.

Instructions for using the **ACAL** feature are located in the Section 9.3 of this manual along with all other information related to calibrating the GFC7002T/GFC7002TU Analyzer.

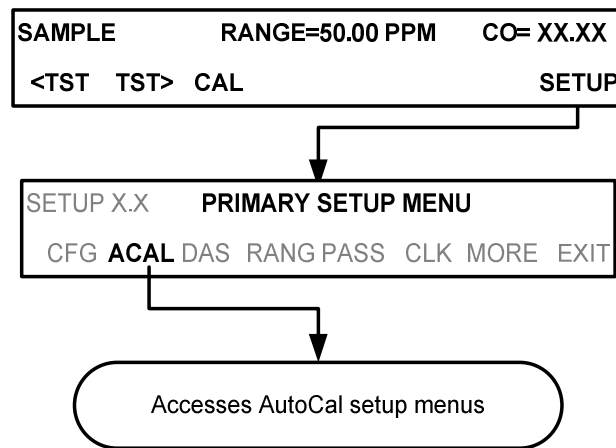

Note: The above screen(s) show CO concentration displayed. Your instrument will indicate and display N₂O concentration.

5.3. SETUP → DAS: INTERNAL DATA ACQUISITION SYSTEM

Use the **SETUP>DAS** menu to capture and record data. Refer to Section 7 for configuration and operation details.

5.4. SETUP → RNGE: ANALOG OUTPUT REPORTING RANGE CONFIGURATION

Use the **SETUP>RNGE** menu to configure output reporting ranges, including scaled reporting ranges to handle data resolution challenges. This section also describes configuration for Single, Dual, and Auto Range modes.

5.4.1. ANALOG OUTPUT RANGES FOR N₂O CONCENTRATION

The analyzer has several active analog output signals, accessible through the **ANALOG OUT** connector on the rear panel.

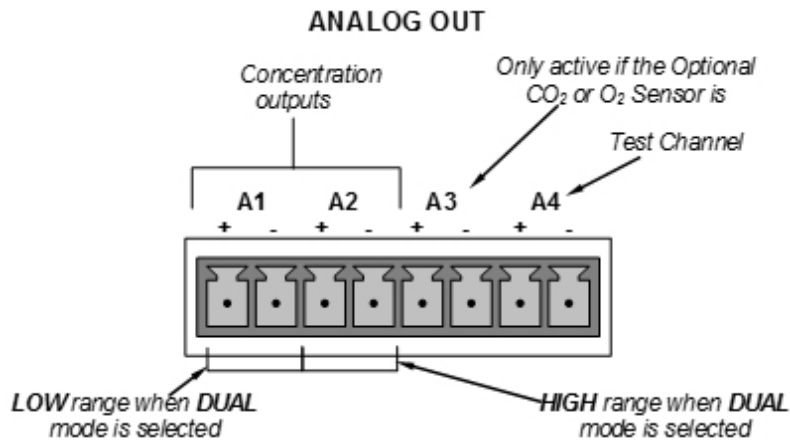

Figure 5-1: Analog Output Connector Pin Out

The outputs can be configured either at the factory or by the user for full scale outputs of 0.1 VDC, 1VDC, 5VDC or 10VDC.

Additionally, **A1**, **A2** and **A3** may be equipped with optional 0-20 mA DC current loop drivers and configured for any current output within that range (e.g. 0-20, 2-20, 4-20, etc.). The user may also adjust the signal level and scaling of the actual output voltage or current to match the input requirements of the recorder or datalogger (See Section 5.8.3.8).

In its basic configuration, the **A1** and **A2** channels output a signal that is proportional to the N₂O concentration of the sample gas. Several modes are available which allow them to operate independently or be slaved together (See Section 5.4.3).

EXAMPLE:

A1 OUTPUT: Output Signal = 0-5 VDC representing 0-1000 ppm concentration values

A2 OUTPUT: Output Signal = 0 – 10 VDC representing 0-500 ppm concentration values.

Output **A3** is only active if the CO₂ or O₂ sensor option is installed. In this case a signal representing the currently measured CO₂ or O₂ concentration is output on this channel.

The output, labeled **A4** is special. It can be set by the user (See Section 5.8.8.1) to output several of the test functions accessible through the <TST TST> buttons of the units sample display.

5.4.2. PHYSICAL RANGE VS ANALOG OUTPUT REPORTING RANGES

Functionally, the GFC7002T Family of N₂O Analyzers have one hardware PHYSICAL RANGE that is capable of determining N₂O concentrations across a very wide array of values.

Table 5-1: GFC7002T Family Physical Range by Model

MODEL	RANGE
GFC7002T	0 – 1000 ppm
GFC7002TU	0 – 5000 ppm

This architecture improves reliability and accuracy by avoiding the need for extra, switchable, gain-amplification circuitry. Once properly calibrated, the analyzer's front panel will accurately report concentrations along the entire span of its physical range.

Because many applications use only a small part of the analyzer's full physical range, this can create data resolution problems for most analog recording devices. For example, in an application where an GFC7002T is being used to measure an expected concentration of typically less than 50 ppm N₂O, the full scale of expected values is only 4% of the instrument's full 1000 ppm measurement range. Unmodified, the corresponding output signal would also be recorded across only 2.5% of the range of the recording device.

The GFC7002T/GFC7002TU Analyzers solve this problem by allowing the user to select a scaled reporting range for the analog outputs that only includes that portion of the physical range relevant to the specific application.

Only this REPORTING RANGE of the analog outputs is scaled; the physical range of the analyzer and the readings displayed on the front panel remain unaltered.

Note

Neither the DAS values stored in the CPU's memory nor the concentration values reported on the front panel are affected by the settings chosen for the reporting range(s) of the instrument.

5.4.3. REPORTING RANGE MODES: SINGLE, DUAL, AUTO RANGES

The GFC7002T/GFC7002TU provides three analog output range modes to choose from.

- Single range (**SNGL**) mode sets a single maximum range for the analog output. If single range is selected both outputs are slaved together and will represent the same measurement span (e.g. 0-50 ppm), however their electronic signal levels may be configured for different ranges (e.g. 0-10 VDC vs. 0-.1 VDC).
- Dual range (**DUAL**) allows the A1 and A2 outputs to be configured with different measurement spans as well as separate electronic signal levels.
- Auto range (**AUTO**) mode gives the analyzer to ability to output data via a low range and high range. When this mode is selected the analyzer will automatically switch between the two ranges dynamically as the concentration value fluctuates.

Range status is also output via the external digital I/O status outputs (See Section 3.3.1.4).

To select the Analog Output Range Type press:

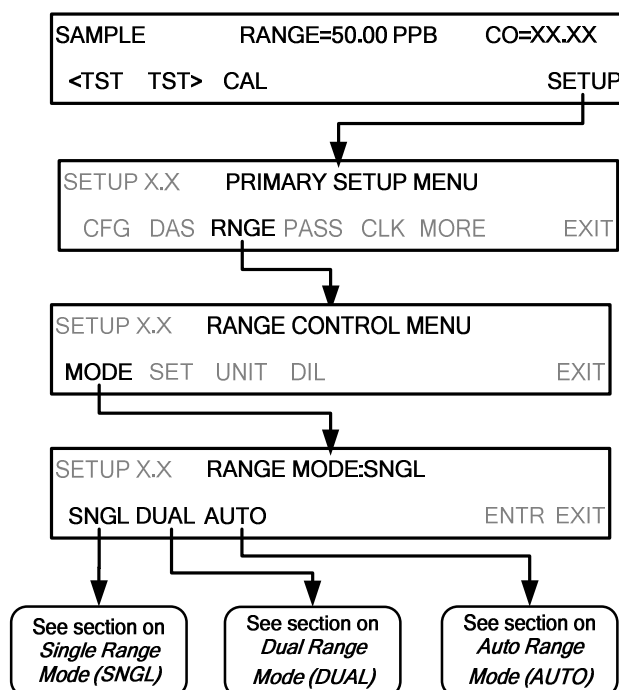

Note: The above screen(s) show CO concentration displayed. Your instrument will indicate and display N₂O concentration.

Upper span limit setting for the individual range modes are shared. Resetting the span limit in one mode also resets the span limit for the corresponding range in the other modes as follows:

<u>SNGL</u> Range	↔	<u>DUAL</u> Range1 Range2	↔	<u>AUTO</u> Low Range High Range
----------------------	---	---------------------------------	---	--

5.4.3.1. SINGLE RANGE MODE (SNGL)

Single Range Mode (SNGL) is the default reporting range mode for the analyzer.

When the single range mode is selected (**SNGL**), all analog N₂O concentration outputs (**A1 and A2**) are slaved together and set to the same reporting range limits (e.g. 500.0 ppb). The span limit of this reporting range can be set to any value within the physical range of the analyzer.

Although both outputs share the same concentration reporting range, the electronic signal ranges of the analog outputs may still be configured for different values (e.g. 0-5 VDC, 0-10 VDC, etc; see Section 0)

To select **SNGL** range mode and to set the upper limit of the range, press:

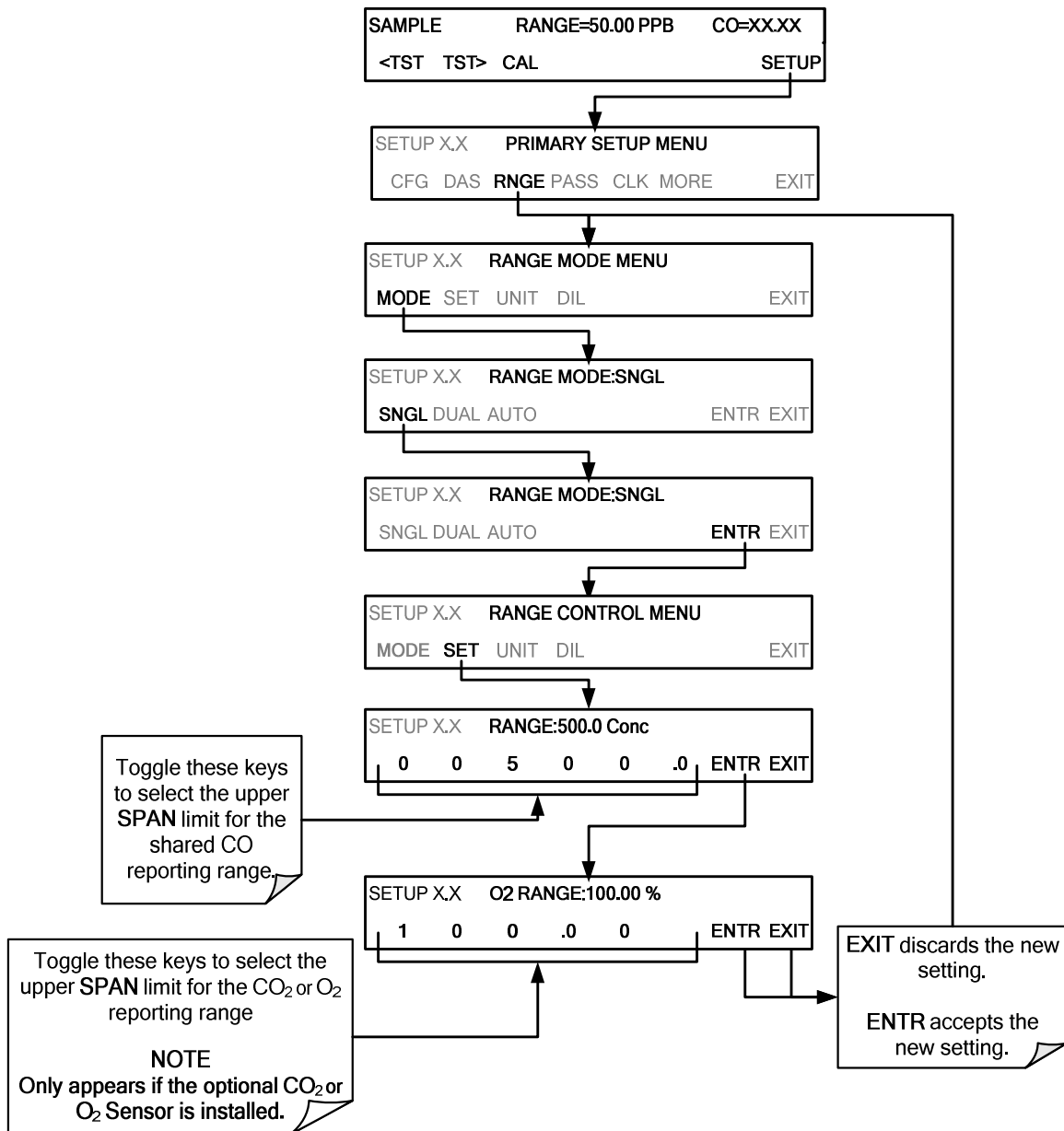

5.4.3.2. DUAL RANGE MODE (DUAL)

Selecting the **DUAL** range mode allows the **A1** and **A2** outputs to be configured with different reporting ranges. The analyzer software calls these two ranges low and high.

- The **LOW** range setting corresponds with the analog output labeled **A1** on the rear panel of the instrument.
- The **HIGH** range setting corresponds with the **A2** output.

While the software names these two ranges low and high, they do not have to be configured that way. For example: The low range can be set for a span of 0-1000 ppm while the high range is set for 0-500 ppm.

In **DUAL** range mode the **RANGE** test function displayed on the front panel will be replaced by two separate functions:

- **RANGE1**: The range setting for the A1 output.
- **RANGE2**: The range setting for the A2 output.

To select the **DUAL** range mode press following buttonstroke sequence

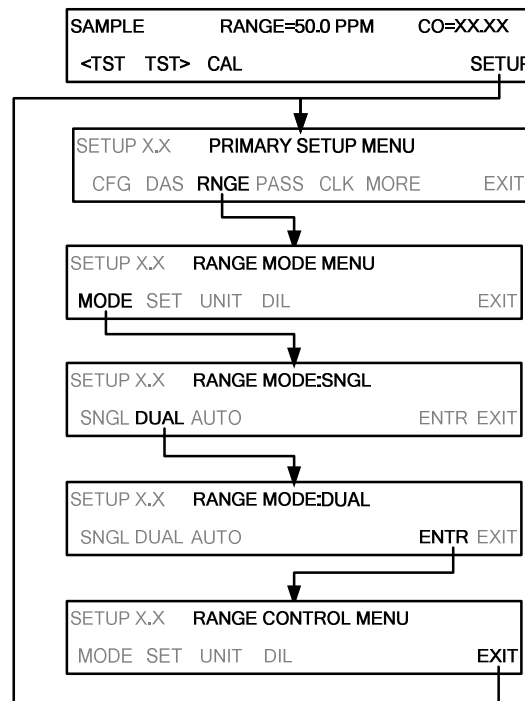

Note: The above screen(s) show CO concentration displayed. Your instrument will indicate and display N₂O concentration.

When the instrument's range mode is set to **DUAL**, the concentration field in the upper right hand corner of the display alternates between displaying the low range value and the high range value. The concentration currently being displayed is identified as follows: **C1= LOW** (or **A1**) and **C2 = HIGH** (or **A2**).

IMPORTANT

IMPACT ON READINGS OR DATA

In DUAL range mode the LOW and HIGH ranges have separate slopes and offsets for computing N₂O concentrations. The two ranges must be independently calibrated.

To set the upper range limit for each independent reporting range, press:

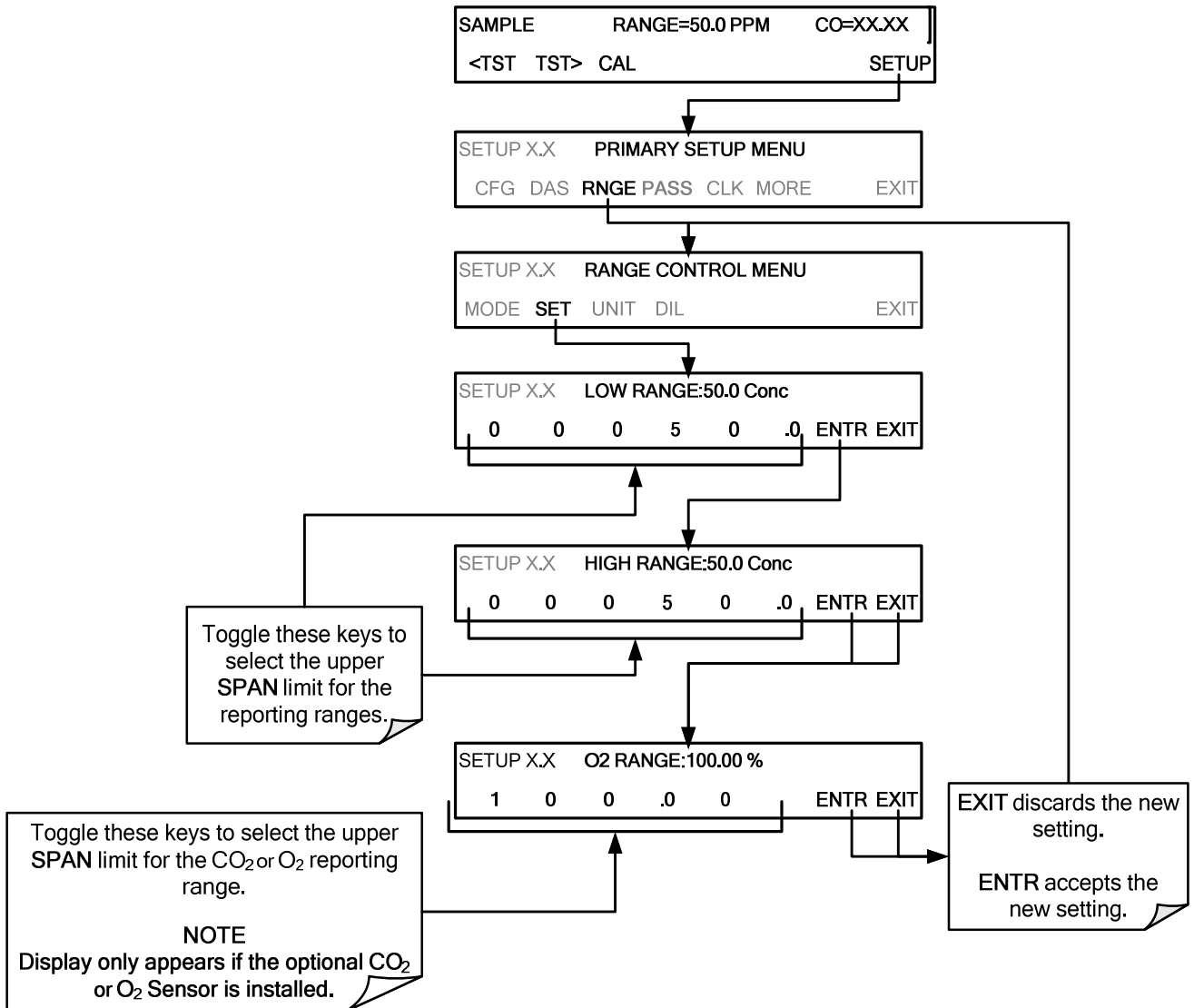

Note: The above screen(s) show CO concentration displayed. Your instrument will indicate and display N₂O concentration.

5.4.3.3. AUTO RANGE MODE (AUTO)

In **AUTO** range mode, the analyzer automatically switches the reporting range between two user-defined ranges (low and high).

- The unit will switch from low range to high range when the N₂O concentration exceeds 98% of the low range span.
- The unit will return from high range back to low range once both the N₂O concentration falls below 75% of the low range span.

In **AUTO** Range Mode the instrument reports the same data in the same range on both the **A1** and **A2** outputs and automatically switches both outputs between ranges as described above. Also the **RANGE** test function displayed on the front panel will be replaced by two separate functions:

- **RANGE1**: The **LOW** range setting for all analog outputs.
- **RANGE2**: The **HIGH** range setting for all analog outputs.

The high/low range status is also reported through the external, digital status bits (See Section 3.3.1.4).

To set individual ranges press the following control button sequence.

Avoid accidentally setting the **LOW** range (**RANGE1**) of the instrument with a higher span limit than the **HIGH** range (**RANGE2**). This will cause the unit to stay in the low reporting range perpetually and defeat the function of the **AUTO** range mode.

The **LOW** and **HIGH** ranges have separate slopes and offsets for computing the CO concentration. The two ranges must be independently calibrated.

Toggle these buttons to select the upper **SPAN** limit for the reporting range.

SAMPLE RANGE=50.0 PPM CO=XX.XX
<TST TST> CAL SETUP

SETUP X.X PRIMARY SETUP MENU
CFG DAS **RNGE** PASS CLK MORE EXIT

SETUP X.X RANGE MODE MENU
MODE SET UNIT DIL EXIT

SETUP X.X RANGE MODE:SNGL
SNGL DUAL **AUTO** DIL ENTR EXIT

SETUP X.X RANGE MODE:AUTO
SNGL DUAL AUTO ENTR EXIT

SETUP X.X RANGE CONTROL MENU
MODE **SET** UNIT DIL EXIT

SETUP X.X LOW RANGE:50.0 Conc
| 0 0 0 5 0 .0 ENTR EXIT

SETUP X.X HIGH RANGE:200.0 Conc
| 0 0 2 0 0 .0 ENTR EXIT

EXIT discards the new setting.
ENTR accepts the new setting.

Note: The above screen(s) show CO concentration displayed. Your instrument will indicate and display N₂O concentration.

5.4.4. RANGE UNITS

The GFC7002T/GFC7002TU can display concentrations in parts per million (10^6 mols per mol, PPM) or milligrams per cubic meter (mg/m^3 , MG). Changing units affects all of the display, COMM port and DAS values for all reporting ranges regardless of the analyzer's range mode. To change the concentration units:

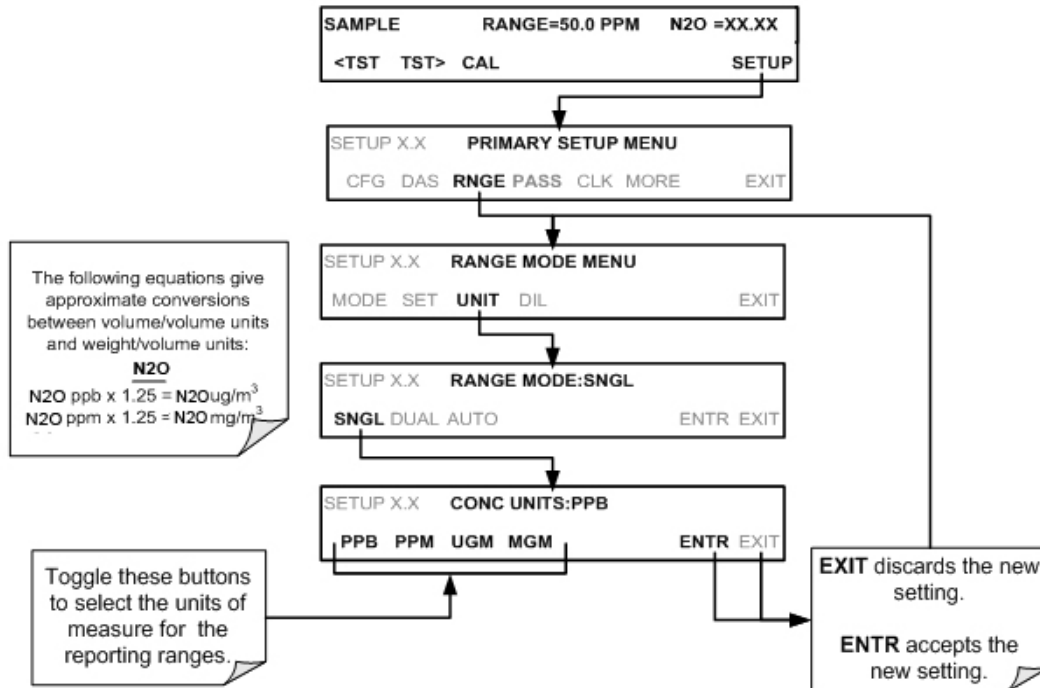

IMPORTANT

IMPACT ON READINGS OR DATA

In order to avoid a reference temperature bias, the analyzer must be recalibrated after every change in reporting units.

IMPORTANT

IMPACT ON READINGS OR DATA

Concentrations displayed in mg/m^3 and ug/m^3 use 0°C and 760 mmHg for Standard Temperature and Pressure (STP). Consult your local regulations for the STP used by your agency.

(Example: US EPA uses 25°C as the reference temperature).

Once the Units of Measurement have been changed from volumetric (ppb or ppm) to mass units ($\mu\text{g}/\text{m}^3$ or mg/m^3) the analyzer **MUST** be recalibrated, as the "expected span values" previously in effect will no longer be valid.

Simply entering new expected span values without running the entire calibration routine **IS NOT** sufficient.

This will also counteract any discrepancies between STP definitions.

5.4.5. DILUTION RATIO (OPTION)

This feature is an optional software utility that allows the user to compensate for any dilution of the sample gas that may occur before it enters the sample inlet. Typically this occurs in continuous emission monitoring (CEM) applications where the sampling method used to remove the gas from the stack dilutes it.

Using the dilution ratio option is a 4-step process:

1. Select the appropriate units of measure (see Section 5.4.4).
2. Select the reporting range mode and set the reporting range upper limit (see Section 5.4.3).
 - Ensure that the upper span limit entered for the reporting range is the maximum expected concentration of the **UNDILUTED** gas.
3. Set the dilution factor as a gain (e.g., a value of 20 means 20 parts diluent and 1 part of sample gas):

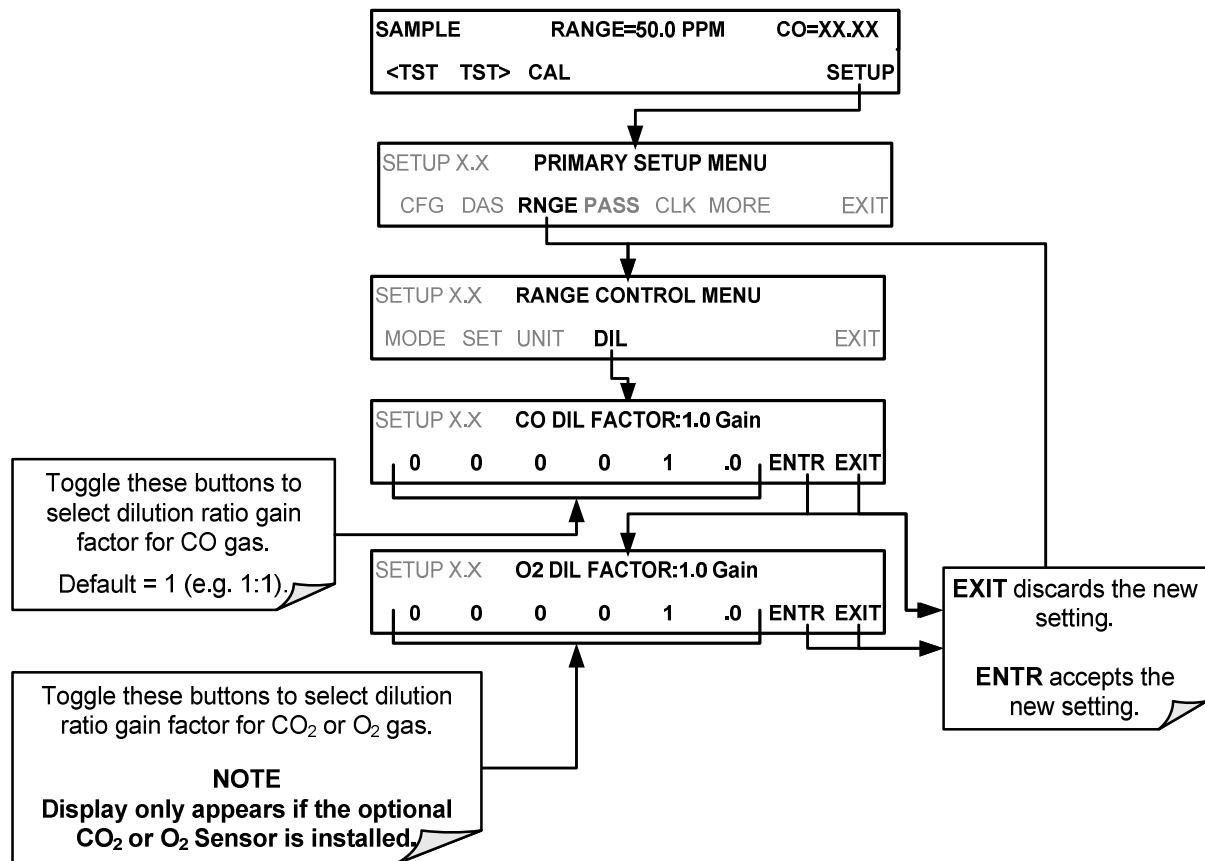

Note: The above screen(s) show CO concentration displayed. Your instrument will indicate and display N₂O concentration.

4. Calibrate the analyzer.
 - Make sure that the calibration span gas is either supplied through the same dilution system as the sample gas or has an appropriately lower actual concentration.

EXAMPLE: If the reporting range limit is set for 100 ppm and the dilution ratio of the sample gas is 20 gain, either:

- a span gas with the concentration of 100 ppm can be used if the span gas passes through the same dilution steps as the sample gas, or;

- a 5 ppm span gas must be used if the span gas **IS NOT** routed through the dilution system.

5.5. SETUP → PASS: PASSWORD PROTECTION

The menu system provides password protection of the calibration and setup functions to prevent unauthorized adjustments. When the passwords have been enabled in the **PASS** menu item, the system will prompt the user for a password anytime a password-protected function (e.g., **SETUP**) is selected. This allows normal operation of the instrument, but requires the password (101) to access to the menus under **SETUP**. When **PASSWORD** is disabled (**SETUP>OFF**), any operator can enter the Primary Setup (**SETUP**) and Secondary Setup (**SETUP>MORE**) menus. Whether **PASSWORD** is enabled or disabled, a password (default 818) is required to enter the **VARs** or **DIAG** menus in the **SETUP>MORE** menu.

Table 5-2: Password Levels

PASSWORD	LEVEL	MENU ACCESS ALLOWED
Null (000)	Operation	All functions of the main menu (top level, or Primary, menu)
101	Configuration/Maintenance	Access to Primary and Secondary SETUP Menus when PASSWORD is enabled
818	Configuration/Maintenance	Access to Secondary SETUP Submenus VARs and DIAG whether PASSWORD is enabled or disabled.

To enable or disable passwords, press:

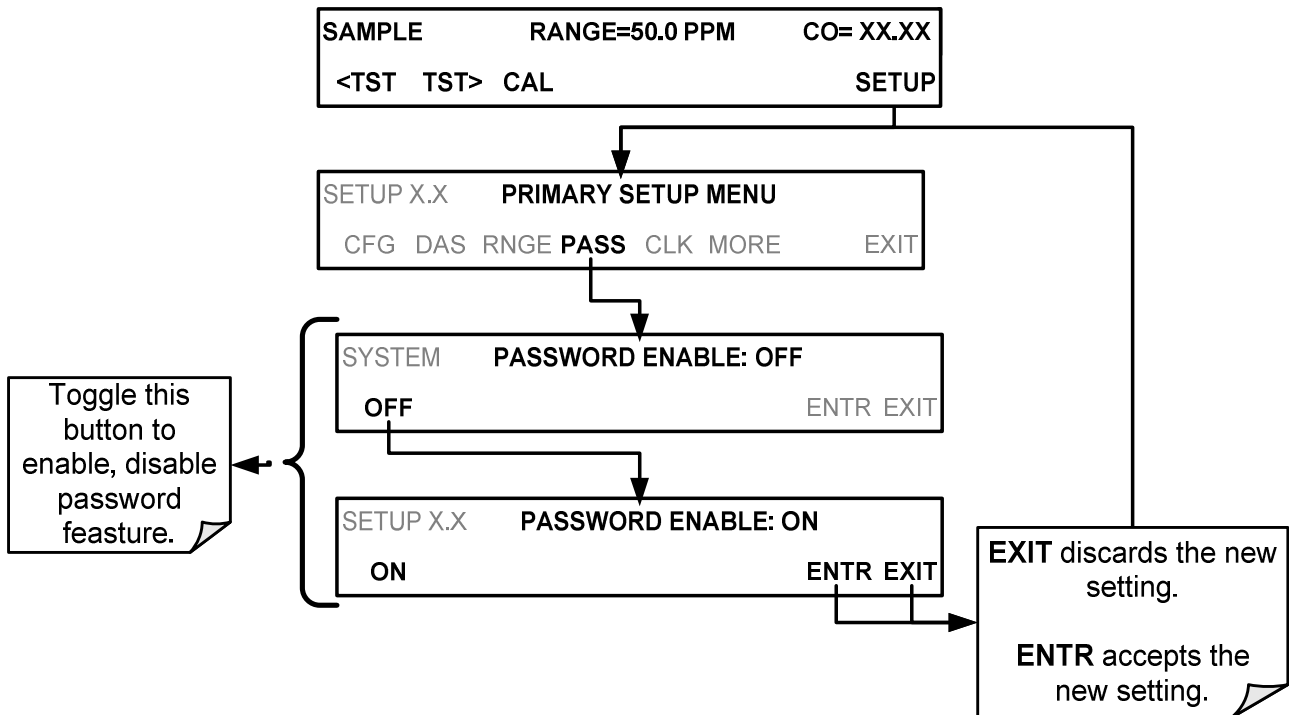

Note: The above screen(s) show CO concentration displayed. Your instrument will indicate and display N₂O concentration.

If the password feature is enabled, then when entering either Calibration or Setup Mode, the default password displayed will be 000, and the new password must be input. Example: If all passwords are enabled, the following control button sequence would be required to enter the **SETUP** menu:

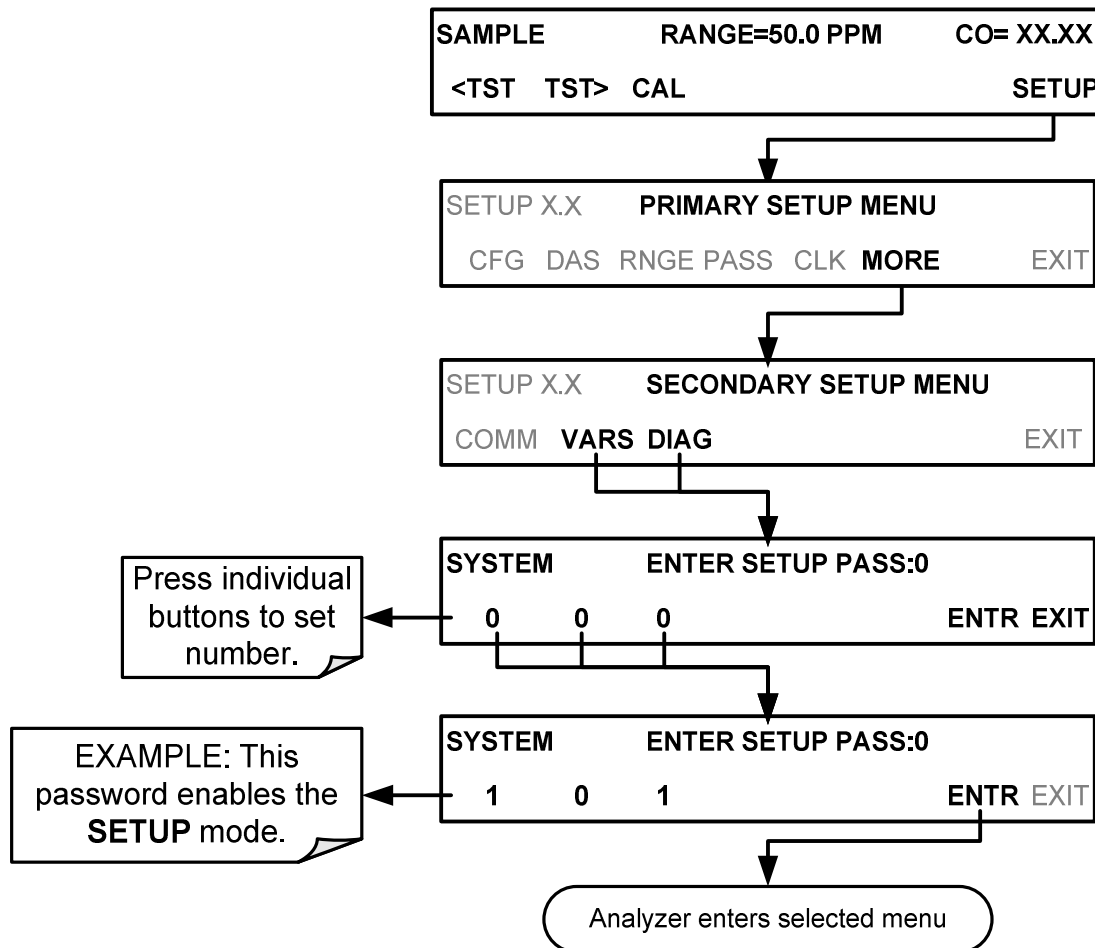

Note: The above screen(s) show CO concentration displayed. Your instrument will indicate and display N₂O concentration.

Note

The instrument still prompts for a password when entering the VARS and DIAG menus, even if passwords are disabled. It will display the default password (818) upon entering these menus.

The user only has to press ENTR to access the password-protected menus but does not have to enter the required number code.

5.6. SETUP → CLK: SETTING THE INTERNAL TIME-OF-DAY CLOCK AND ADJUSTING SPEED

5.6.1.1. SETTING THE INTERNAL CLOCK'S TIME AND DAY

The GFC7002T/GFC7002TU has a time of day clock that supports the **DURATION** step of the automatic calibration (**ACAL**) sequence feature, time of day **TEST** function, and time stamps on for the **DAS** feature and most **COMM** port messages.

To set the clock's time and day, press:

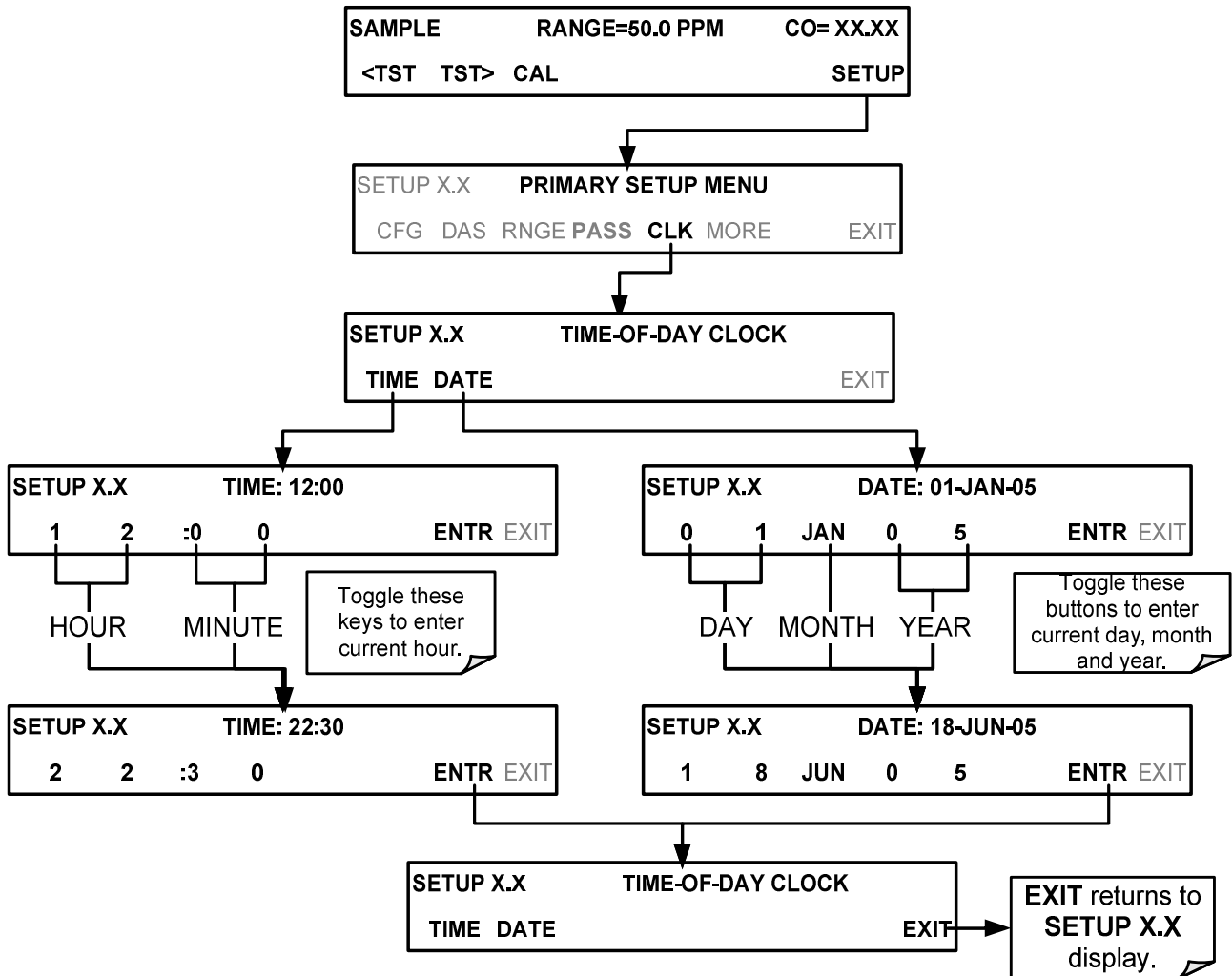

Note: The above screen(s) show CO concentration displayed. Your instrument will indicate and display N₂O concentration.

5.6.1.2. ADJUSTING THE INTERNAL CLOCK'S SPEED

In order to compensate for CPU clocks which run faster or slower, you can adjust a variable called **CLOCK_ADJ** to speed up or slow down the clock by a fixed amount every day.

The **CLOCK_AD** variable is accessed via the **VARS** submenu: To change the value of this variable, press:

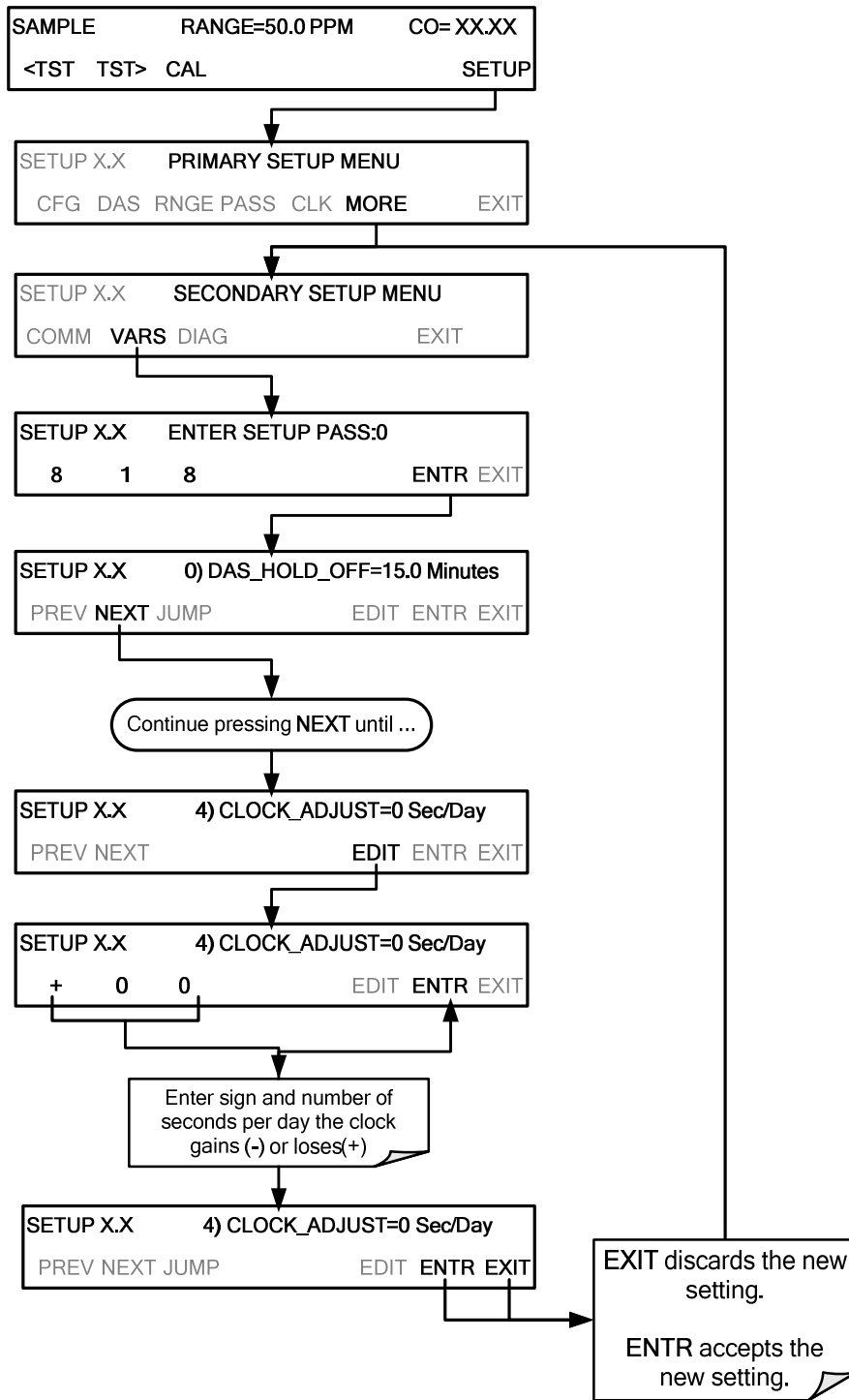

Note: The above screen(s) show CO concentration displayed. Your instrument will indicate and display N₂O concentration.

SETUP →Comm: Communications Ports

This section introduces the communications setup menu; Section 6 provides the setup instructions and operation information. Press SETUP>ENTR>MORE>COMM to arrive at the communications menu.

5.6.2. ID (MACHINE IDENTIFICATION)

Press ID to display and/or change the Machine ID, which must be changed to a unique identifier (number) when more than one instrument of the same model is used:

- in an RS-232 multidrop configuration (Sections 3.3.1.9 and **Error! Reference source not found.**)
- on the same Ethernet LAN (Section 6.5)

The default ID is the same as the model number; for the Model T100, the ID is 0100. Press any button(s) in the MACHINE ID menu (Figure 5-2) until the Machine ID Parameter field displays the desired identifier.

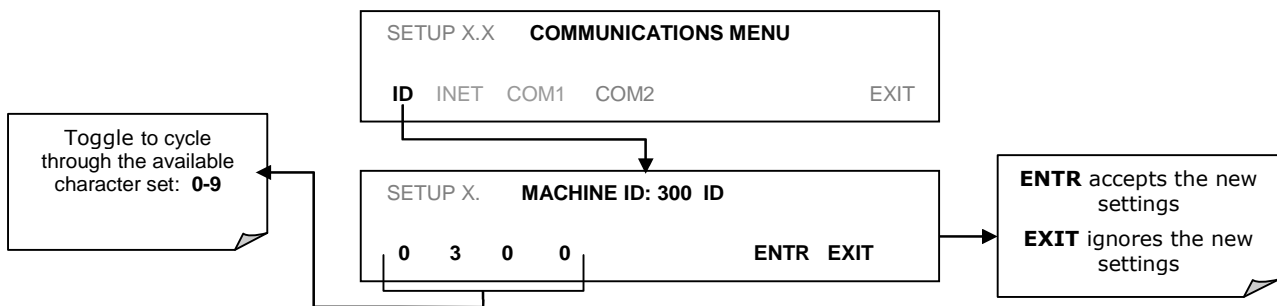

Figure 5-2: COMM– Machine ID

The ID can be any 4-digit number and can also be used to identify analyzers in any number of ways (e.g. location numbers, company asset number, etc.)

5.6.3. INET (ETHERNET)

Use SETUP>COMM>INET to configure Ethernet communications, whether manually or via DHCP. Please see Section 6.5 for configuration details.

5.6.4. COM1 AND COM2 (MODE, BAUD RATE AND TEST PORT)

Use the SETUP>COMM>COM1[COM2] menus to:

- configure communication modes (Section 6.2.1)
- view/set the baud rate (Section 6.2.2)
- test the connections of the com ports (Section 6.2.3).

Configuring COM1 or COM2 requires setting the DCE DTE switch on the rear panel. Section 6.1 provides DCE DTE information.

5.7. SETUP →VARS: VARIABLES SETUP AND DEFINITION

The GFC7002T/GFC7002TU has several user-adjustable software variables, which define certain operational parameters. Usually, these variables are automatically set by the instrument's firmware, but can be manually redefined using the **VARS** menu.

The following table lists all variables that are available within the 818 password protected level. See Appendix A-2 for a detailed listing of all of the GFC7002T/GFC7002TU variables that are accessible through the remote interface.

Table 5-3: Variable Names (VARS)

NO.	VARIABLE	DESCRIPTION	ALLOWED VALUES	VARS DEFAULT VALUES
0	DAS_HOLD_OFF	Changes the Internal Data Acquisition System (DAS) HOLDOFF timer (Section 7.1.11). No data is stored in the DAS channels during situations when the software considers the data to be questionable such as during warm up of just after the instrument returns from one of its calibration mode to SAMPLE Mode.	May be set for intervals between 0.5 – 20 min	15 min.
1	CONC_PRECISION	Allows the user to set the number of significant digits to the right of the decimal point display of concentration and stability values.	AUTO, 1, 2, 3, 4	AUTO
2	DYN_ZERO ¹	Dynamic zero automatically adjusts offset and slope of the N ₂ O response when performing a zero point calibration during an AutoCal (see Section 9.3).	ON/OFF	OFF
3	DYN_SPAN ¹	Dynamic span automatically adjusts the offsets and slopes of the N ₂ O response when performing a slope calibration during an AutoCal (see Section 9.3).	ON/OFF	OFF
4	CLOCK_ADJ	Adjusts the speed of the analyzer's clock. Choose the + sign if the clock is too slow, choose the - sign if the clock is too fast.	-60 to +60 s/day	0 sec
5	STABIL_GAS ²	Selects which gas measurement is displayed when the STABIL test function is selected.	CO; CO ₂ & O ₂	CO

¹ Use of the DYN_ZERO and DYN_SPAN features are not allowed for applications requiring EPA equivalency.
² This VARS only appears if either the optional O₂ or CO₂ sensors are installed.

IMPORTANT

IMPACT ON READINGS OR DATA

There are more VARS available when using the password, 929, for configuration. Use caution when pressing any buttons while in this setup. Any changes made may alter the performance of the instrument or cause the instrument to not function properly. Note that if there is an accidental change to a setup parameter, press EXIT to discard the changes.

To access and navigate the **VARs** menu, use the following button sequence.

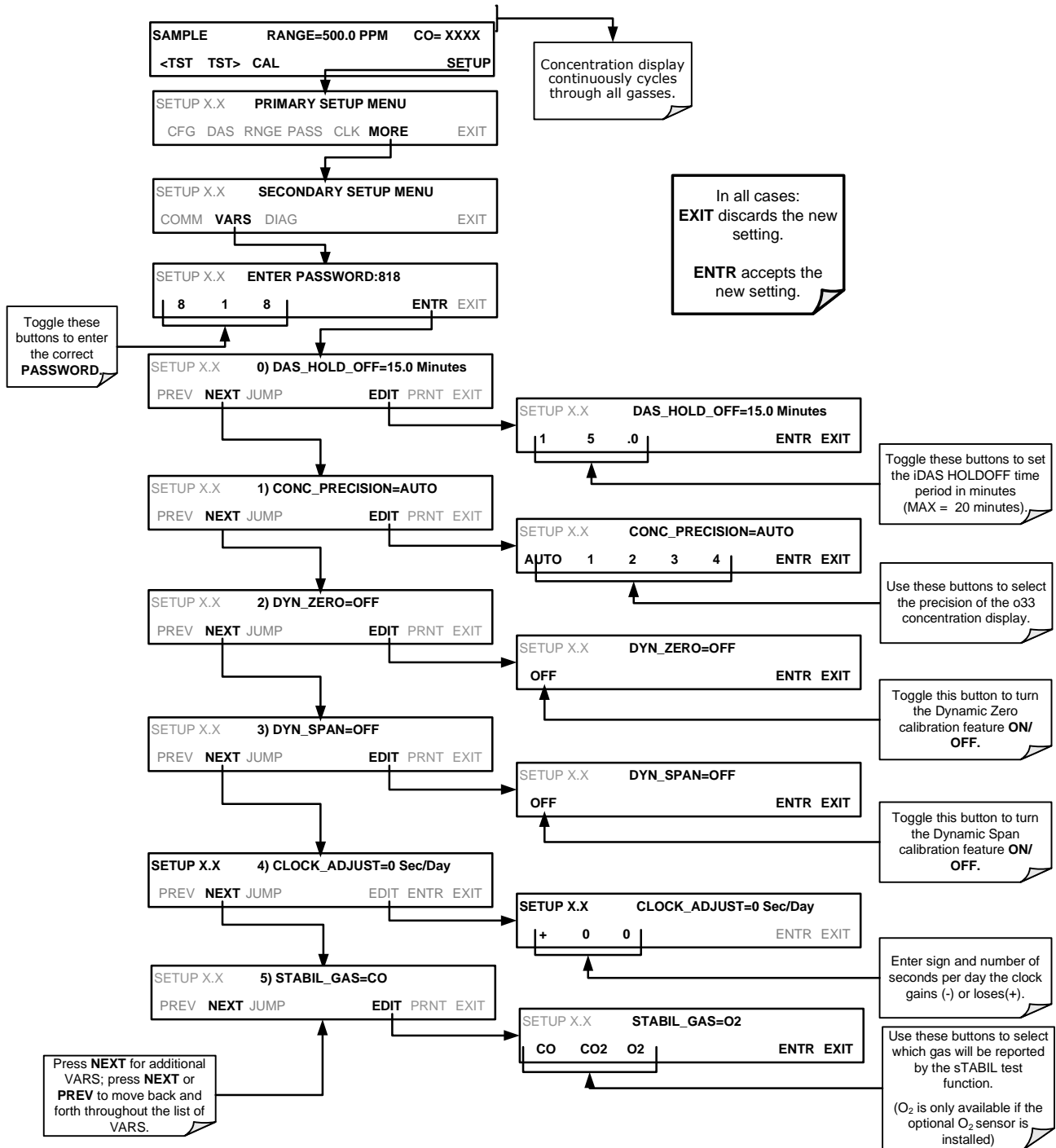

Note: The above screen(s) show CO concentration displayed. Your instrument will indicate and display N₂O concentration.

5.8. SETUP →DIAG: DIAGNOSTICS FUNCTIONS

A series of diagnostic tools is grouped together under the **SETUP→MORE→DIAG** menu, as these parameters are dependent on firmware revision (see Appendix A). These

tools can be used in a variety of troubleshooting and diagnostic procedures and are referred to in many places of the maintenance and trouble-shooting sections of this manual.

The various operating modes available under the **DIAG** menu are:

Table 5-4: Diagnostic Mode (DIAG) Functions

DIAG SUBMENU	SUBMENU FUNCTION	Front Panel Mode Indicator	MANUAL SECTION
SIGNAL I/O	Allows observation of all digital and analog signals in the instrument. Allows certain digital signals such as valves and heaters to be toggled ON and OFF .	DIAG SIGNAL I/O	5.8.1, 11.1.3 and 11.5.8.1
ANALOG OUTPUT	When entered, the analyzer performs an analog output step test. This can be used to calibrate a chart recorder or to test the analog output accuracy.	DIAG ANALOG OUTPUT	5.8.2 and 11.5.8.2
ANALOG I/O CONFIGURATION	This submenu allows the user to configure the analyzer's analog output channels, including choosing what parameter will be output on each channel. Instructions that appear here allow adjustment and calibration of the voltage signals associated with each output as well as calibration of the analog to digital converter circuitry on the motherboard.	DIAG ANALOG I/O CONFIGURATION	5.8.3
ELECTRICAL TEST	When activated, the analyzer performs an electrical test, which generates a voltage intended to simulate the measure and reference outputs of the SYNC/DEMODO board to verify the signal handling and conditioning of these signals.	DIAG ELECTRICAL TEST	5.8.4 and 11.5.7.2
DARK CALIBRATION¹	Disconnects the preamp from synchronous demodulation circuitry on the SYNC/DEMODO PCA to establish the dark offset values for the measure and reference channel.	DIAG DARK CALIBRATION	5.8.5 and 9.5.1
PRESSURE CALIBRATION¹	Allows the user to calibrate the sample pressure sensor.	DIAG PRESSURE CALIBRATION	5.8.6 and 9.5.2
FLOW CALIBRATION¹	This function is used to calibrate the gas flow output signals of sample gas and ozone supply.	DIAG FLOW CALIBRATION	5.8.7 and 9.5.3
TEST CHAN OUTPUT	Selects one of the available test channel signals to output over the A4 analog output channel.	DIAG TEST CHAN OUTPUT	5.8.8 and 11.5.8.2

¹ These settings are retained after exiting DIAG mode.

To access the **DIAG** functions press the following buttons:

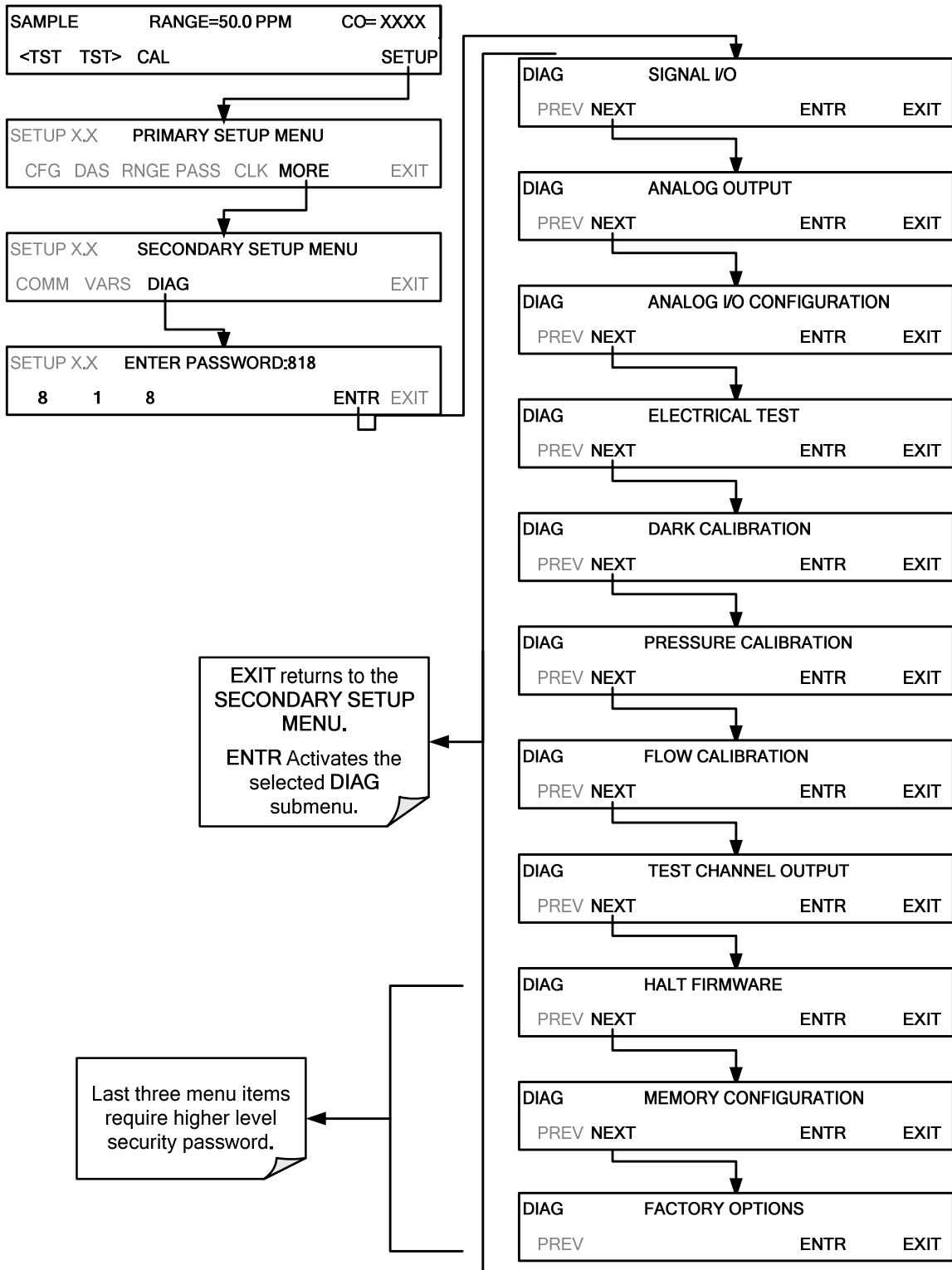

Note: The above screen(s) show CO concentration displayed. Your instrument will indicate and display N₂O concentration.

5.8.1. SIGNAL I/O

The signal I/O diagnostic mode allows a user to review and change the digital and analog input/output functions of the analyzer. Refer to Appendix A-4 for a full list of the parameters available for review under this menu.

IMPORTANT

IMPACT ON READINGS OR DATA

Any changes of signal I/O settings will remain in effect only until the signal I/O menu is exited. Exceptions are the ozone generator override and the flow sensor calibration, which remain as entered when exiting.

Access the SIGNAL I/O test mode from the DIAG Menu:

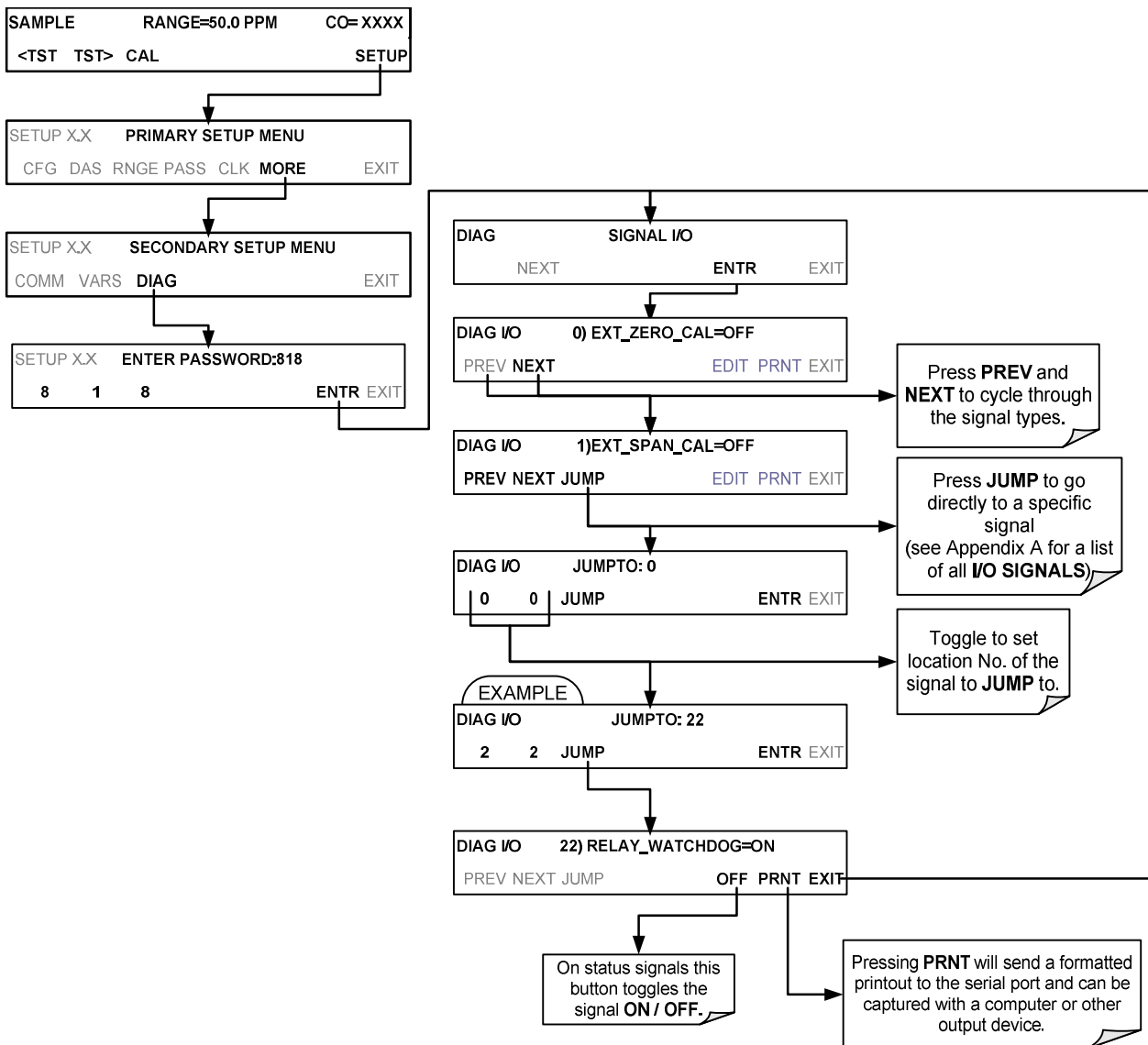

Note: The above screen(s) show CO concentration displayed. Your instrument will indicate and display N₂O concentration.

5.8.2. ANALOG OUTPUT

Analog Output is used as a step test to check the accuracy and proper operation of the analog outputs. The test forces all four analog output channels to produce signals ranging from 0% to 100% of the full scale range in 20% increments. This test is useful to verify the operation of the data logging/recording devices attached to the analyzer. (See also Section 11.5.8.2).

Access the Analog Output Step Test from the DIAG Menu as follows:

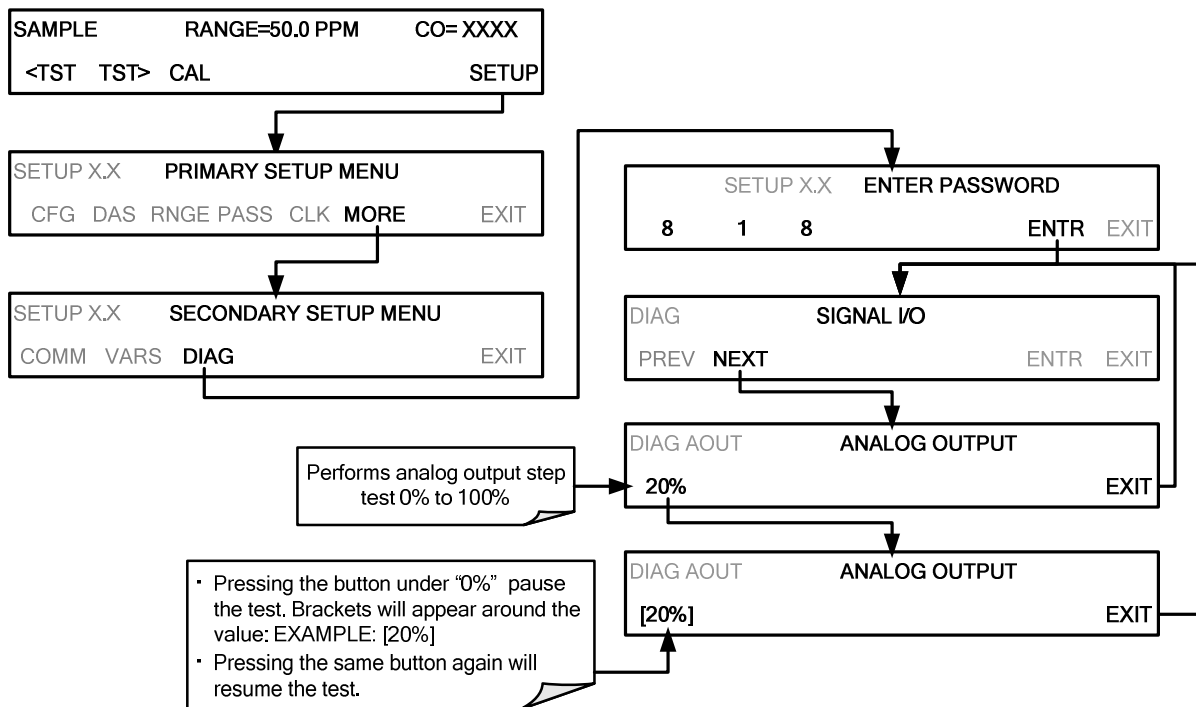

Note: The above screen(s) show CO concentration displayed. Your instrument will indicate and display N₂O concentration.

5.8.3. ANALOG I/O CONFIGURATION

The GFC7002T/GFC7002TU Analyzer comes equipped with four analog outputs.

- The first two outputs (**A1 & A2**) carry analog signals that represent the currently measured concentration of N₂O (see Section 5.4.1).
- The third output (**A3**) is only active if the analyzer is equipped with one of the optional 2nd gas sensors (e.g. O₂ or CO₂).
- The fourth output (**A4**) outputs a signal that can be set to represent the current value of one of several test functions (see Table 5-9).

Table 5-5 lists the analog I/O functions that are available in the GFC7002T/GFC7002TU Analyzer.

Table 5-5: DIAG - Analog I/O Functions

SUB MENU	OUTPUT CHANNEL	FUNCTION
AOUT CALIBRATED	ALL	Initiates a calibration of the A1 , A2 , A3 and A4 analog output channels that determines the slope and offset inherent in the circuitry of each output. These values are stored and applied to the output signals by the CPU automatically.
CONC_OUT_1	A1	Sets the basic electronic configuration of the A1 output (N ₂ O Concentration). There are four options: 1. RANGE ¹ : Selects the signal type (voltage or current loop) and level of the output. 2. REC OFS ¹ : Allows them input of a DC offset to let the user manually adjust the output level. 3. AUTO CAL : Enables / Disables the AOUT CALIBRATED feature. 4. CALIBRATED : Performs the same calibration as AOUT CALIBRATED , but on this one channel only.
CONC_OUT_2	A2	5. Same as for CONC_OUT_1 but for analog channel A2 .
CONC_OUT_3	A3	6. Same as for CONC_OUT_1 but for analog channel A3 but only if either the optional O ₂ or CO ₂ sensors are installed.
TEST OUTPUT	A4	7. Same as for CONC_OUT_1 but for analog channel A4 (TEST CHANNEL).
AIN CALIBRATED	N/A	Initiates a calibration of the A-to-D Converter circuit located on the Motherboard.
XIN1 . . . XIN8		For each of 8 external analog input channels, shows the gain, offset, engineering units, and whether the channel is to show up as a Test function.
¹ Any changes made to RANGE or REC_OF S require recalibration of this output.		

To access the **ANALOG I/O CONFIGURATION** submenu, press:

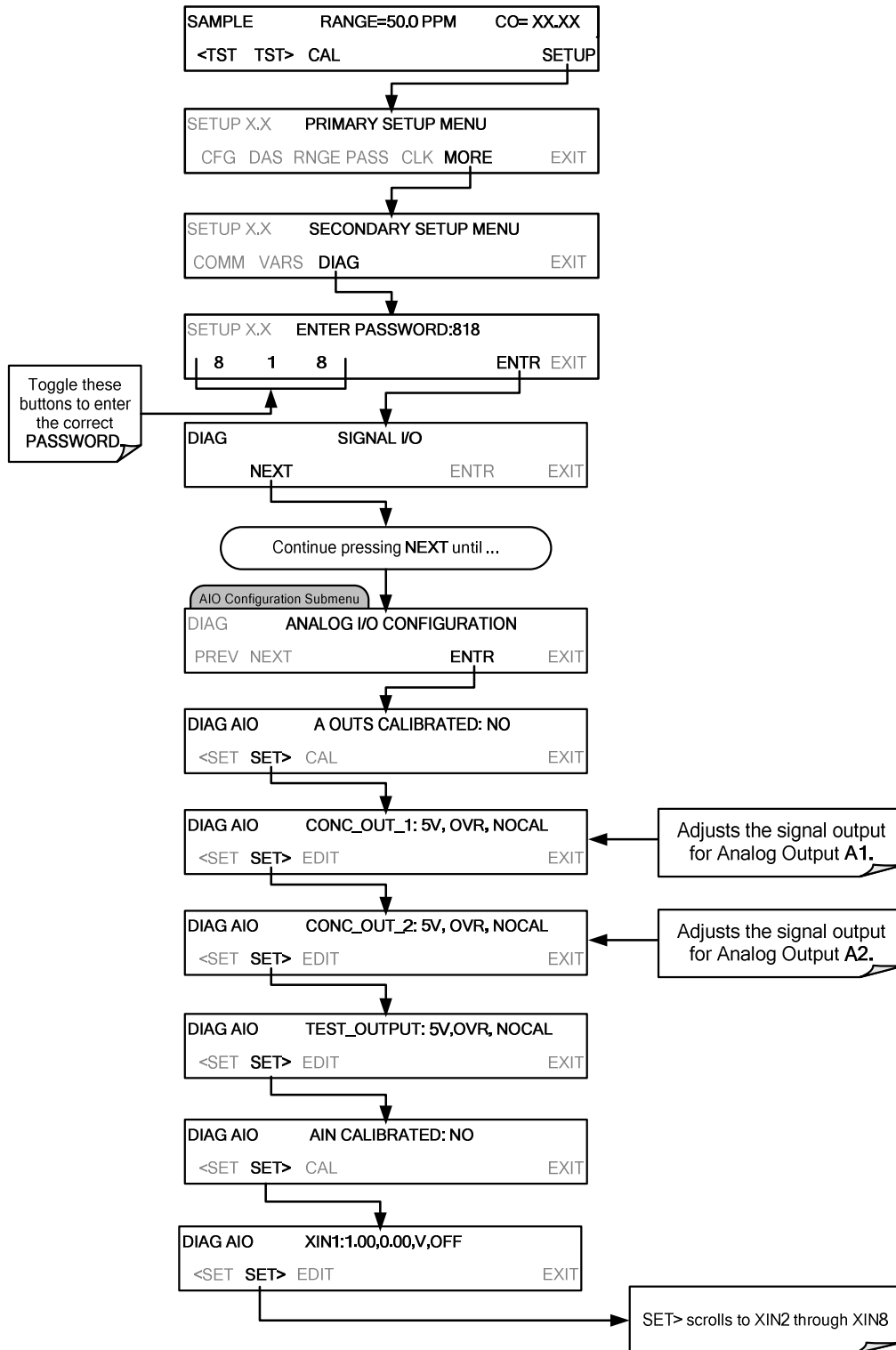

Figure 5-3: Accessing the Analog I/O Configuration Submenus

Note: The above screen(s) show CO concentration displayed. Your instrument will indicate and display N₂O concentration.

Analog Output Voltage / Current Range Selection

In its standard configuration, each of the analog outputs is set to output a 0–5 VDC signals. Several other output ranges are available. Each range has is usable from -5% to + 5% of the rated span.

Table 5-6: Analog Output Voltage Ranges

RANGE NAME	RANGE SPAN	MINIMUM OUTPUT	MAXIMUM OUTPUT
0.1V	0-100 mVDC	-5 mVDC	105 mVDC
1V	0-1 VDC	-0.05 VDC	1.05 VDC
5V	0-5 VDC	-0.25 VDC	5.25 VDC
10V	0-10 VDC	-0.5 VDC	10.5 VDC
<ul style="list-style-type: none"> The default offset for all VDC ranges is 0-5 VDC. 			
CURR	0-20 mA	0 mA	20 mA
<ul style="list-style-type: none"> While these are the physical limits of the current loop modules, typical applications use 2-20 or 4-20 mA for the lower and upper limits. Please specify desired range when ordering this option. The default offset for all current ranges is 0 mA. Current outputs are available only on A1-A3. 			

To change the output type and range, select the **ANALOG I/O CONFIGURATION** submenu from the **DIAG** Menu (see Figure 5-3) then press:

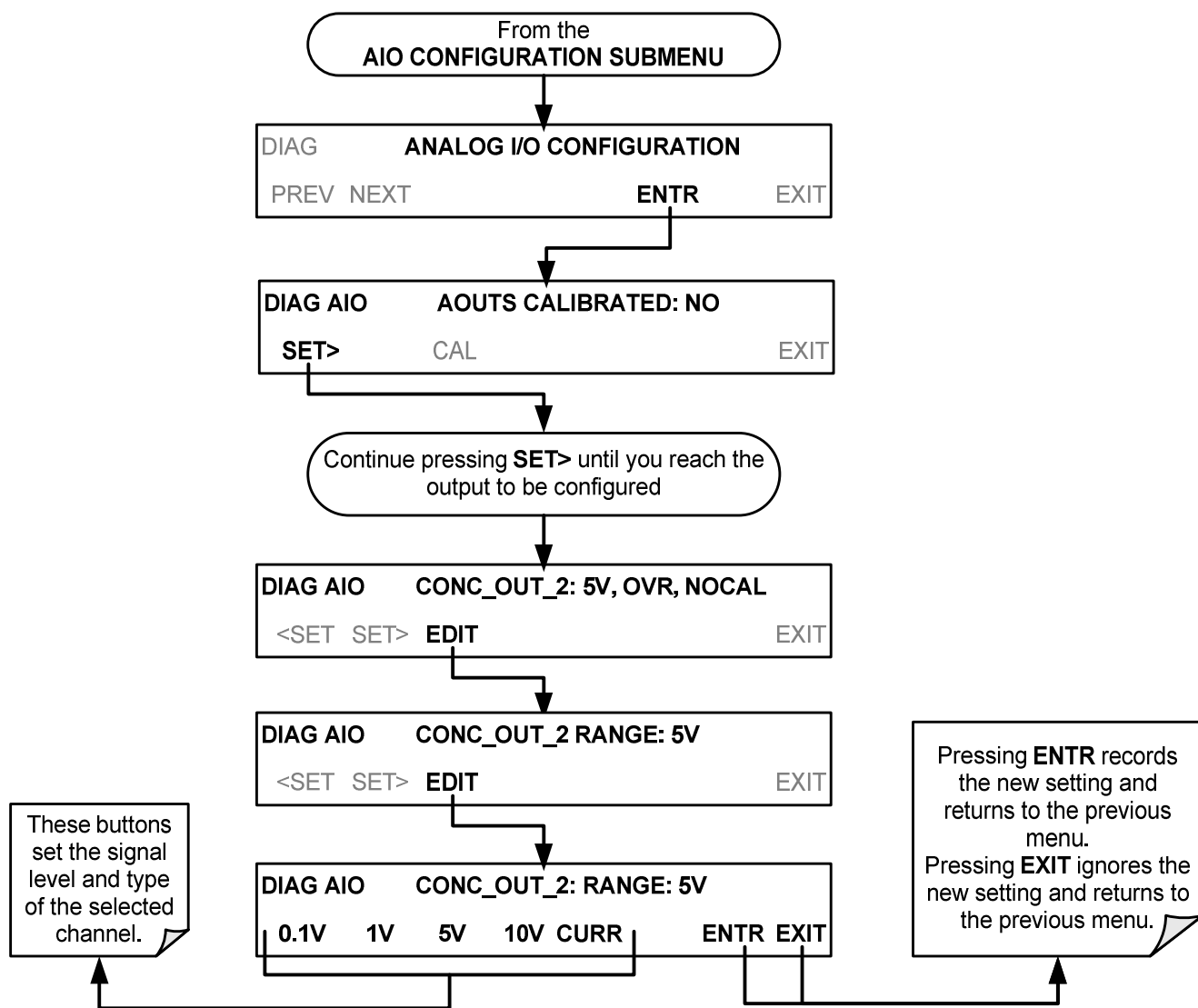

5.8.3.1. ANALOG OUTPUT CALIBRATION

Analog output calibration should be carried out on first startup of the analyzer (performed in the factory as part of the configuration process) or whenever recalibration is required. The analog outputs can be calibrated automatically, either as a group or individually, or adjusted manually.

In its default mode, the instrument is configured for automatic calibration of all channels, which is useful for clearing any analog calibration warnings associated with channels that will not be used or connected to any input or recording device, e.g., datalogger.

Manual calibration should be used for the 0.1V range or in cases where the outputs must be closely matched to the characteristics of the recording device. Manual calibration requires the AUTOCAL feature to be disabled.

Automatic calibration can be performed via the **CAL** button located inside The **AOUTS CALIBRATION** submenu. By default, the analyzer is configured so that calibration of analog outputs can be initiated as a group with the **AOUT CALIBRATION** command. The outputs can also be calibrated individually, but this requires the AUTOCAL feature be disabled.

5.8.3.2. ENABLING OR DISABLING THE AUTOCAL FOR AN INDIVIDUAL ANALOG OUTPUT

To enable or disable the **AutoCal** feature for an individual analog output, elect the **ANALOG I/O CONFIGURATION** submenu (see Figure 5-3) then press:

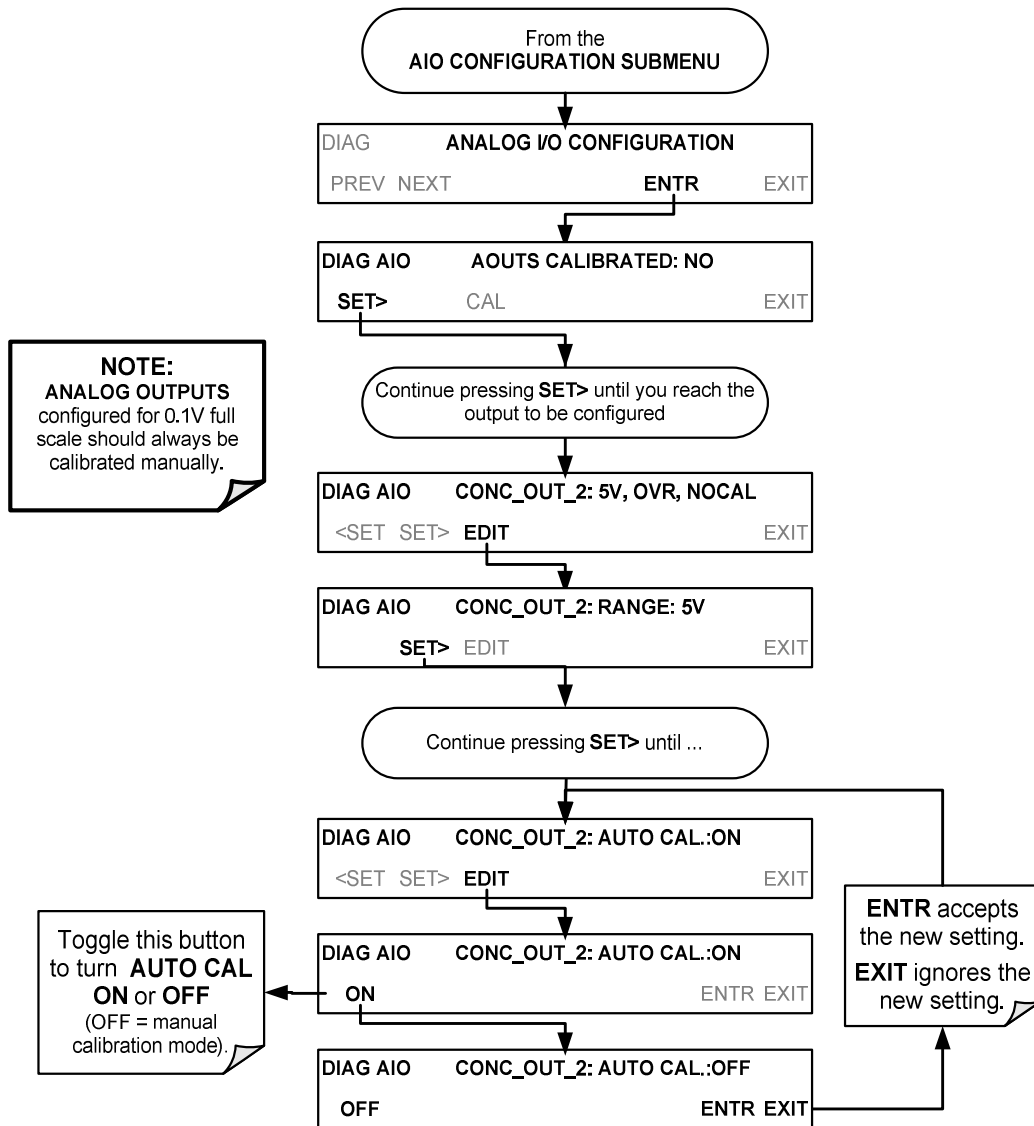

5.8.3.3. AUTOMATIC CALIBRATION OF THE ANALOG OUTPUTS

To calibrate the outputs as a group with the **AOUTS CALIBRATION** command, select the **ANALOG I/O CONFIGURATION** submenu (see Figure 5-3) then press:

IMPORTANT

IMPACT ON READINGS OR DATA

Before performing this procedure, make sure that the AUTO CAL for each analog output is enabled. (See Section 5.9.3.3).

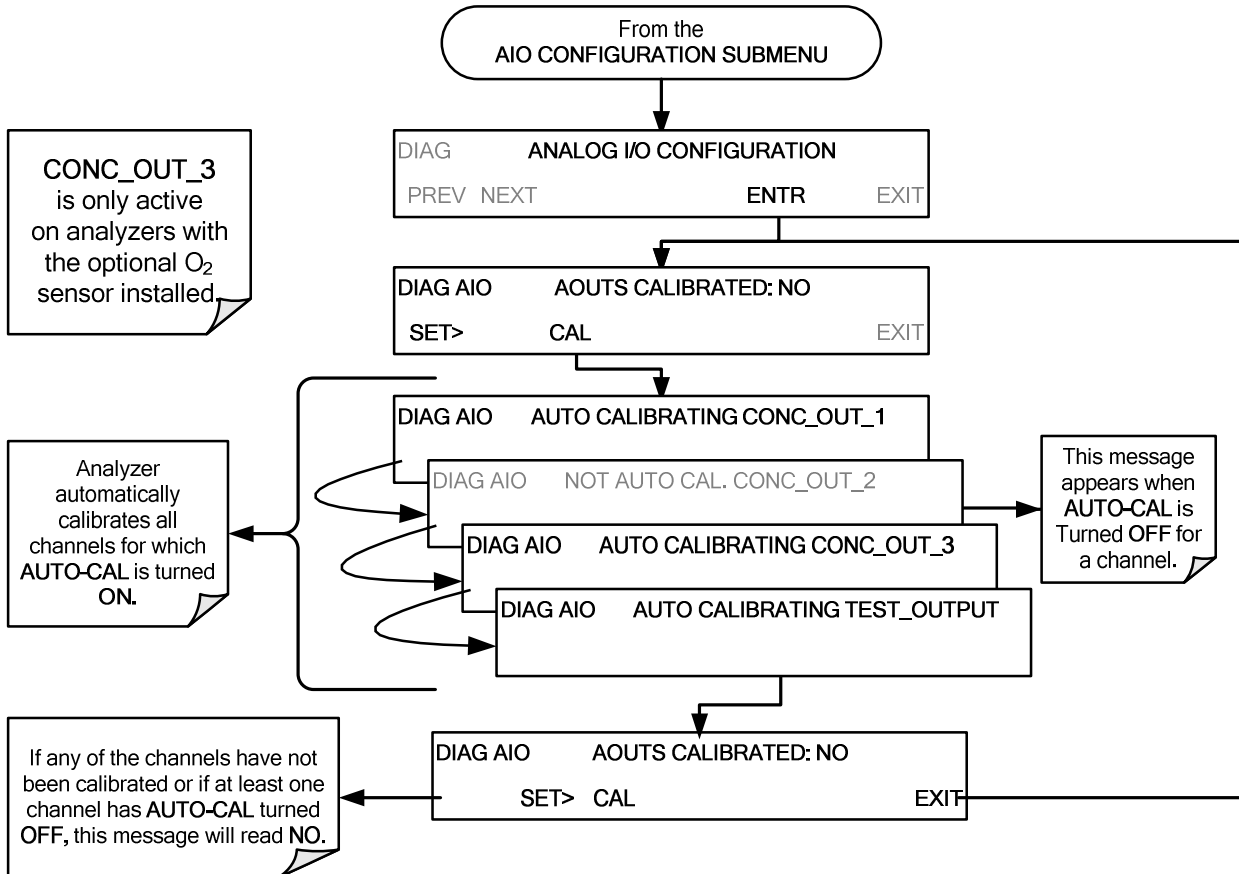

IMPORTANT

IMPACT ON READINGS OR DATA

Manual calibration should be used for any analog output set for a 0.1V output range or in cases where the outputs must be closely matched to the characteristics of the recording device.

5.8.3.4. INDIVIDUAL CALIBRATION OF THE ANALOG OUTPUTS

To use the **AUTO CAL** feature to initiate an automatic calibration for an individual analog output, select the **ANALOG I/O CONFIGURATION** submenu (see Figure 5-3) then press:

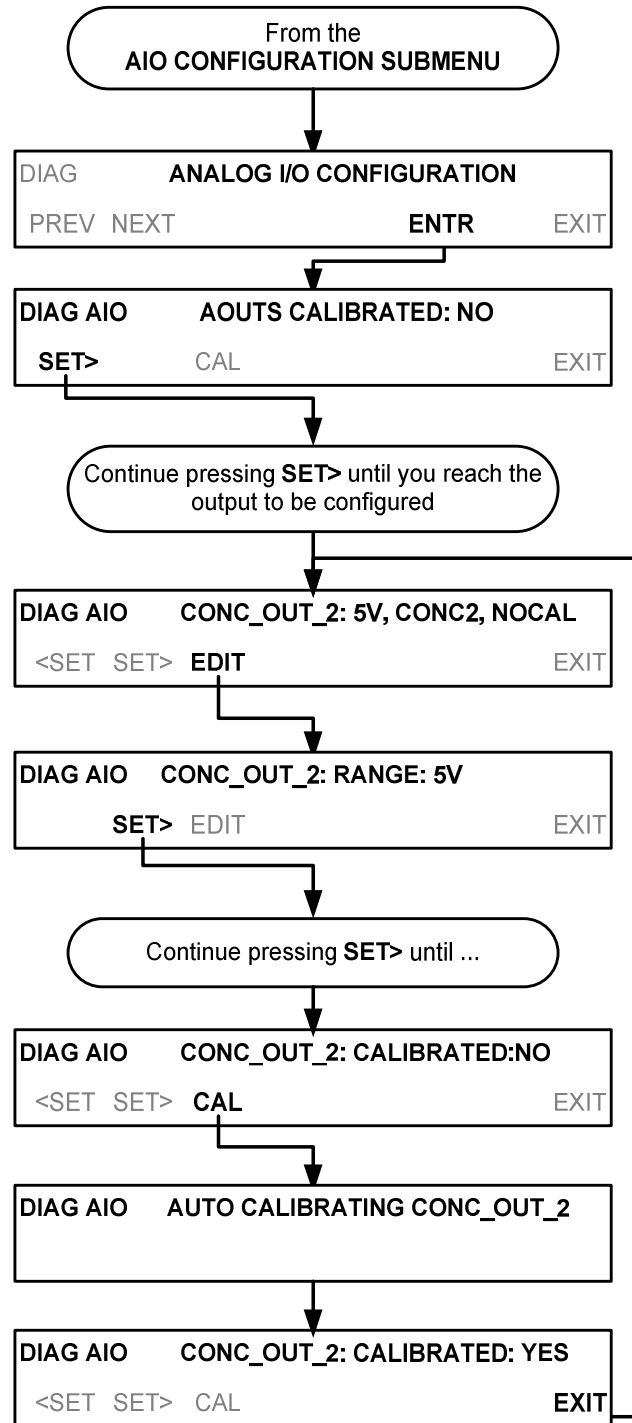

5.8.3.5. MANUAL CALIBRATION OF THE ANALOG OUTPUTS CONFIGURED FOR VOLTAGE RANGES

For highest accuracy, the voltages of the analog outputs can be manually calibrated.

Note

The menu for manually adjusting the analog output signal level will only appear if the AUTO-CAL feature is turned off for the channel being adjusted (see Section 5.9.3.3).

Calibration is performed with a voltmeter connected across the output terminals and by changing the actual output signal level using the front panel buttons in 100, 10 or 1 count increments. See Figure 3-9 for pin assignments and diagram of the analog output connector.

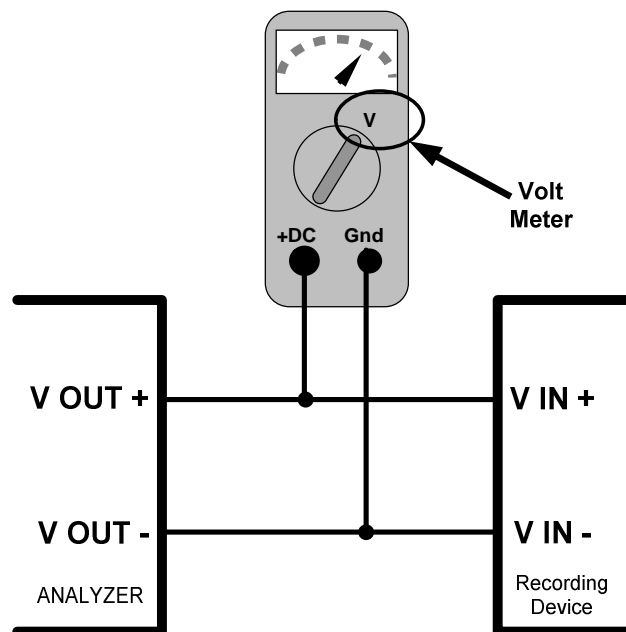
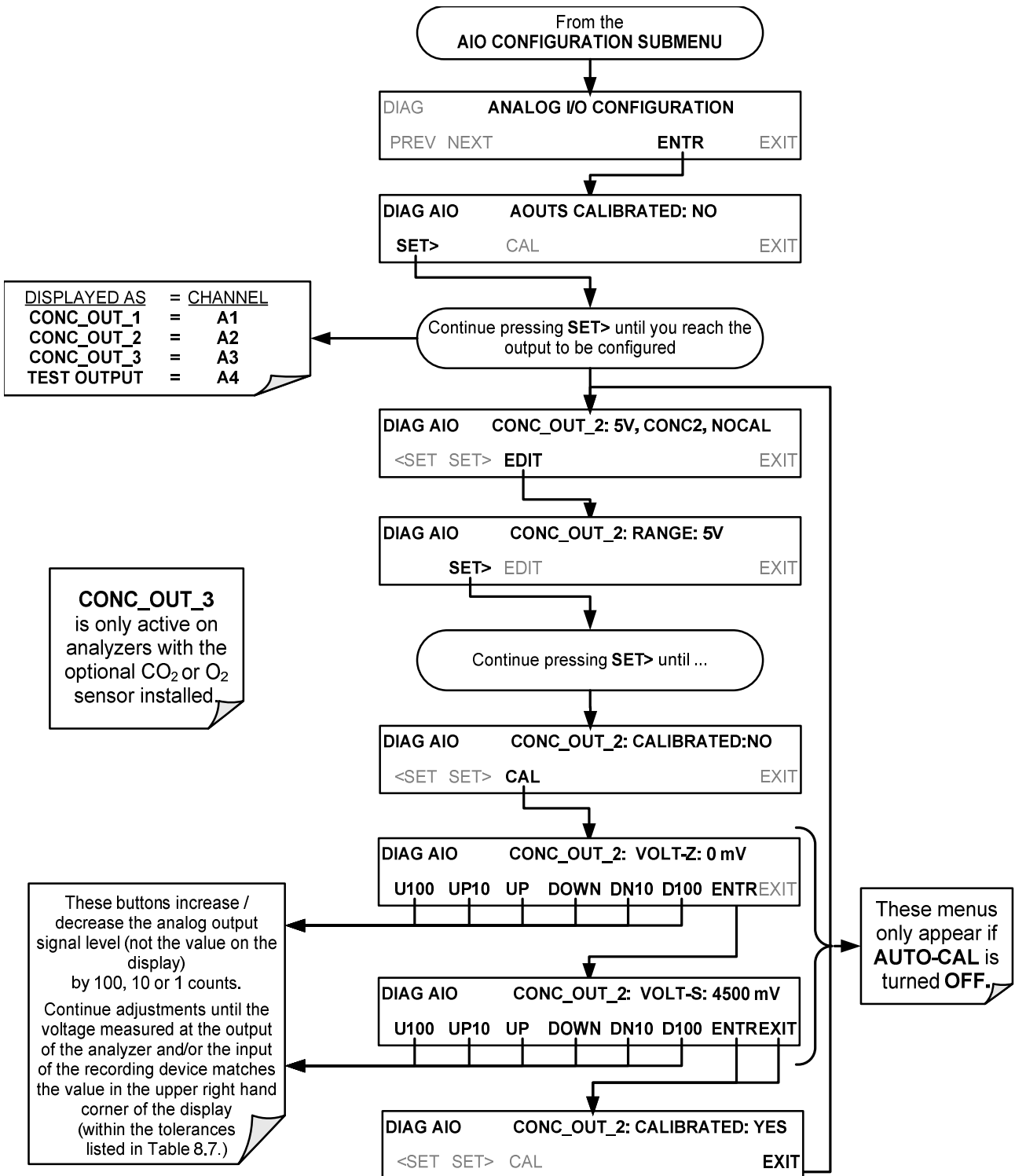

Figure 5-4: Setup for Checking / Calibrating DCV Analog Output Signal Levels

Table 5-7: Voltage Tolerances for the TEST CHANNEL Calibration

FULL SCALE	ZERO TOLERANCE	SPAN VOLTAGE	SPAN TOLERANCE	MINIMUM ADJUSTMENT (1 count)
0.1 VDC	$\pm 0.0005\text{V}$	90 mV	$\pm 0.001\text{V}$	0.02 mV
1 VDC	$\pm 0.001\text{V}$	900 mV	$\pm 0.001\text{V}$	0.24 mV
5 VDC	$\pm 0.002\text{V}$	4500 mV	$\pm 0.003\text{V}$	1.22 mV
10 VDC	$\pm 0.004\text{V}$	4500 mV	$\pm 0.006\text{V}$	2.44 mV

To adjust the signal levels of an analog output channel manually, select the **ANALOG I/O CONFIGURATION** submenu (see Figure 5-3) then press:



5.8.3.6. MANUAL ADJUSTMENT OF CURRENT LOOP OUTPUT SPAN AND OFFSET

A current loop option may be purchased for the **A1**, **A2** and **A3** analog outputs of the analyzer. This option places circuitry in series with the output of the D-to-A converter on the motherboard that changes the normal DC voltage output to a 0-20 milliamp signal (see Section 3.3.1.4).

- The outputs can be ordered scaled to any set of limits within that 0-20 mA range, however most current loop applications call for either 0-20 mA or 4-20 mA range spans.
- All current loop outputs have a +5% over range. Ranges whose lower limit is set above 1 mA also have a -5% under range.

To switch an analog output from voltage to current loop, follow the instructions in Section 0 (select **CURR** from the list of options on the “Output Range” menu).

Adjusting the signal zero and span levels of the current loop output is done by raising or lowering the voltage output of the D-to-A converter circuitry on the analyzer’s motherboard. This raises or lowers the signal level produced by the current loop option circuitry.

The software allows this adjustment to be made in 100, 10 or 1 count increments. Since the exact amount by which the current signal is changed per D-to-A count varies from output-to-output and instrument-to-instrument, you will need to measure the change in the signal levels with a separate, current meter placed in series with the output circuit. See Figure 3-9 for pin assignments and diagram of the analog output connector.

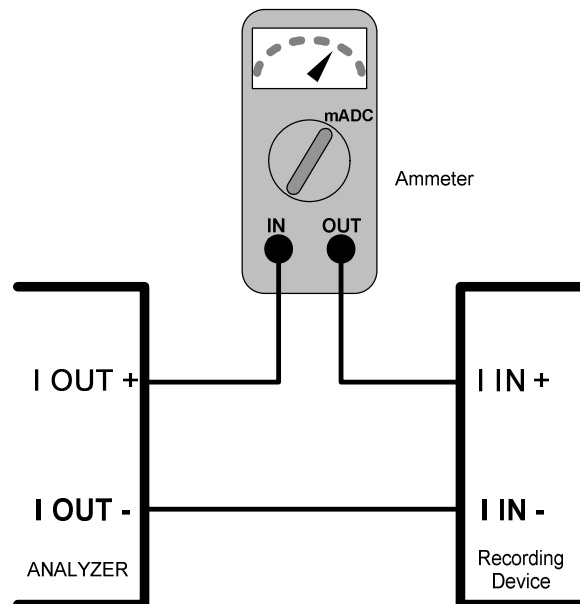

Figure 5-5: Setup for Checking / Calibration Current Output Signal Levels Using an Ammeter



CAUTION GENERAL SAFETY HAZARD

Do not exceed 60 V peak voltage between current loop outputs and instrument ground.

To adjust the zero and span signal levels of the current outputs, select the **ANALOG I/O CONFIGURATION** submenu (see Figure 5-3) then press:

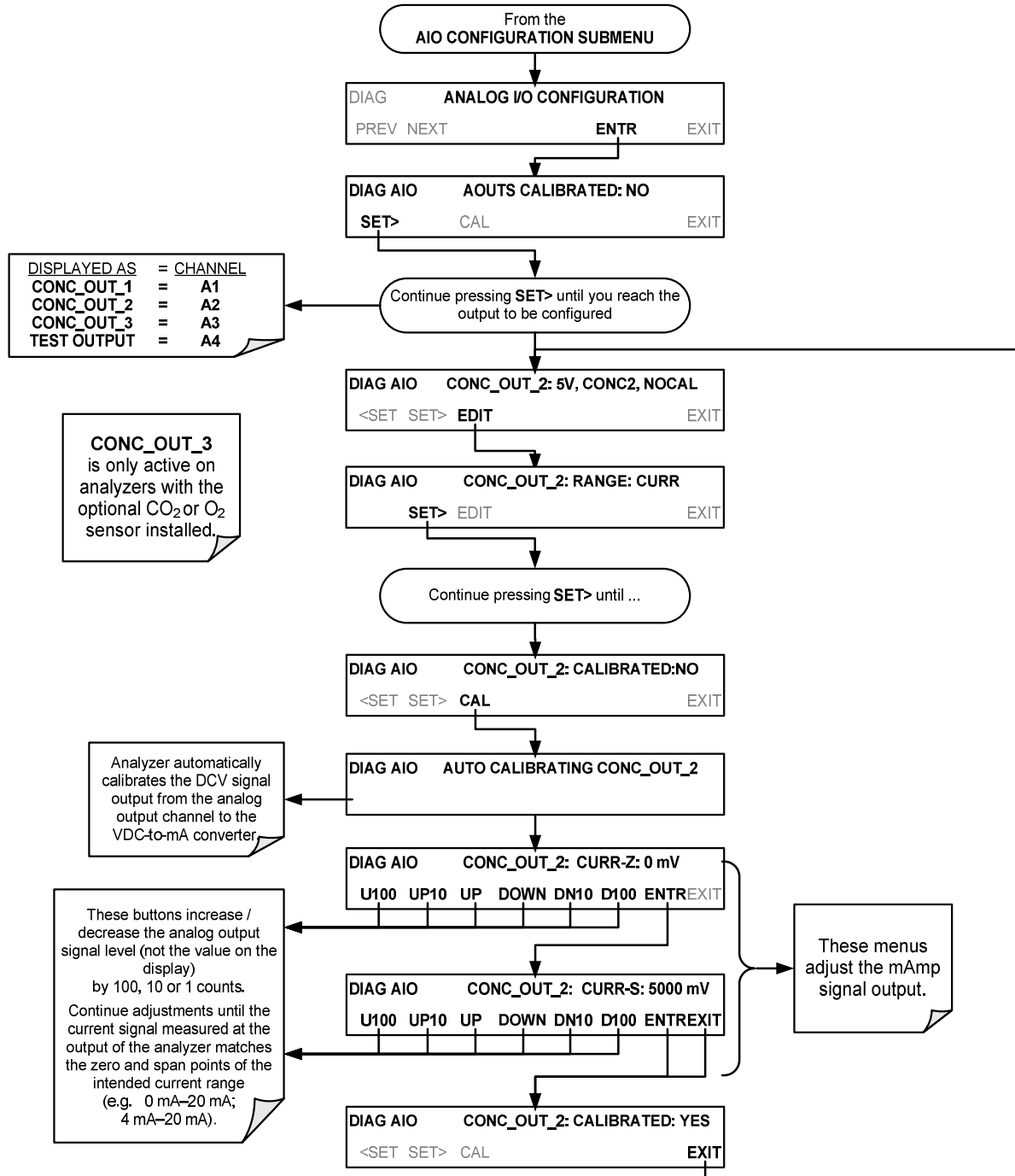

An alternative method for measuring the output of the Current Loop converter is to connect a 250 ohm $\pm 1\%$ resistor across the current loop output in lieu of the current meter (see Figure 3-9 for pin assignments and diagram of the analog output connector). This allows the use of a voltmeter connected across the resistor to measure converter output as VDC or mVDC.

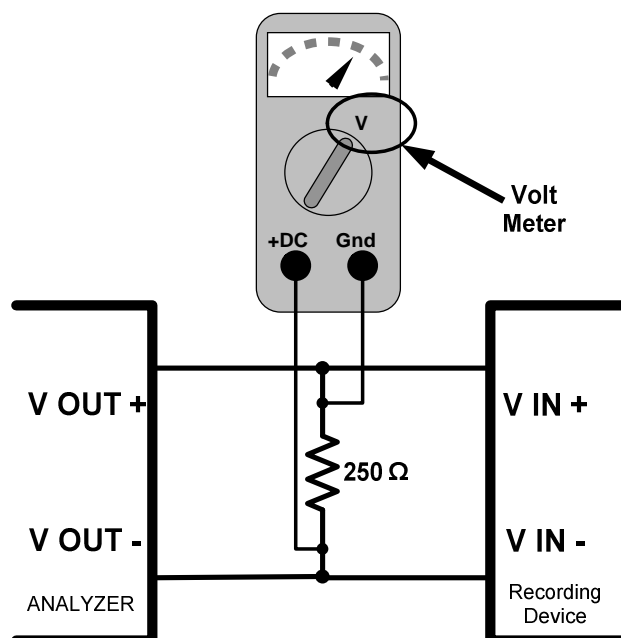

Figure 5-6: Alternative Setup Using 250Ω Resistor for Checking Current Output Signal Levels

In this case, follow the procedure above but adjust the output for the following values:

Table 5-8: Current Loop Output Check

% FS	Voltage across Resistor for 2-20 mA	Voltage across Resistor for 4-20 mA
0	500 mVDC	1000 mVDC
100	5000 mVDC	5000 mVDC

5.8.3.7. TURNING AN ANALOG OUTPUT OVER-RANGE FEATURE ON/OFF

In its default configuration, a $\pm 5\%$ over-range is available on each of the GFC7002T/GFC7002TU Analyzer's analog outputs. This over-range can be disabled if your recording device is sensitive to excess voltage or current.

To turn the over-range feature on or off, select the **ANALOG I/O CONFIGURATION** submenu (see Figure 5-3) then press:

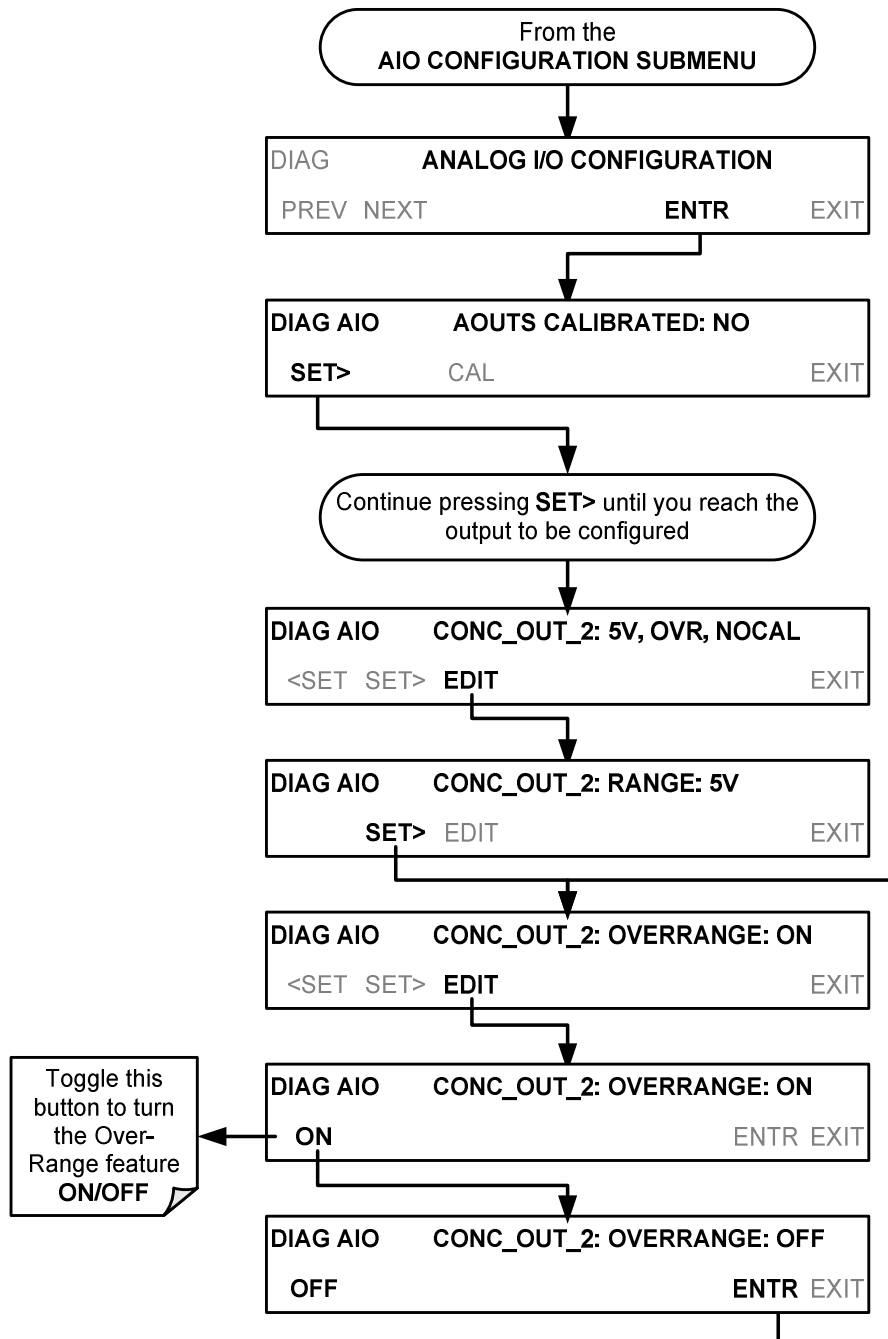

5.8.3.8. ADDING A RECORDER OFFSET TO AN ANALOG OUTPUT

Some analog signal recorders require that the zero signal is significantly different from the baseline of the recorder in order to record slightly negative readings from noise around the zero point. This can be achieved in the GFC7002T/GFC7002TU by defining a zero offset, a small voltage (e.g., 10% of span).

To add a zero offset to a specific analog output channel, select the **ANALOG I/O CONFIGURATION** submenu (see Figure 5-3) then press:

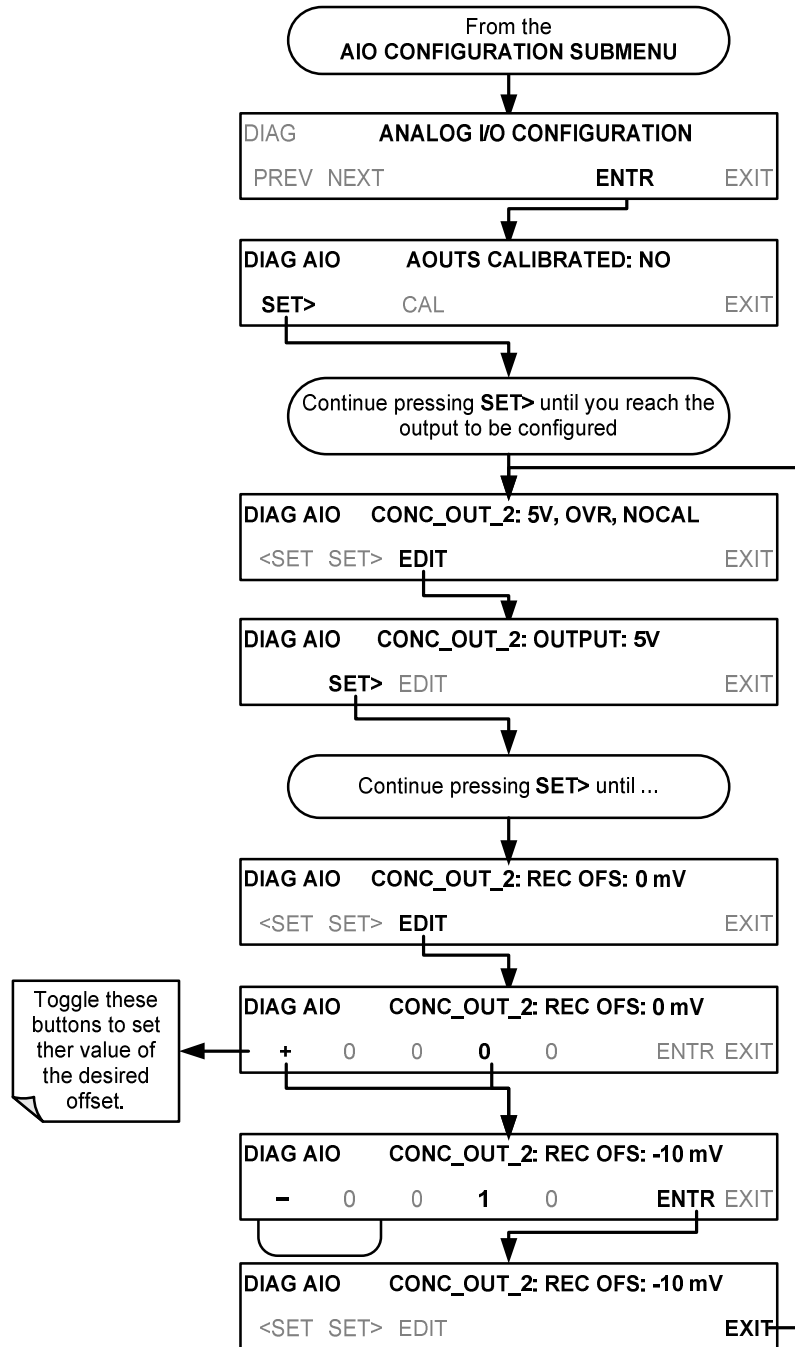

5.8.3.9. AIN CALIBRATION

This is the submenu to conduct a calibration of the GFC7002T/GFC7002TU Analyzer’s analog inputs. This calibration should only be necessary after major repair such as a replacement of CPU, motherboard or power supplies.

To perform an analog input calibration, select the **ANALOG I/O CONFIGURATION** submenu (see Figure 5-3) then press:

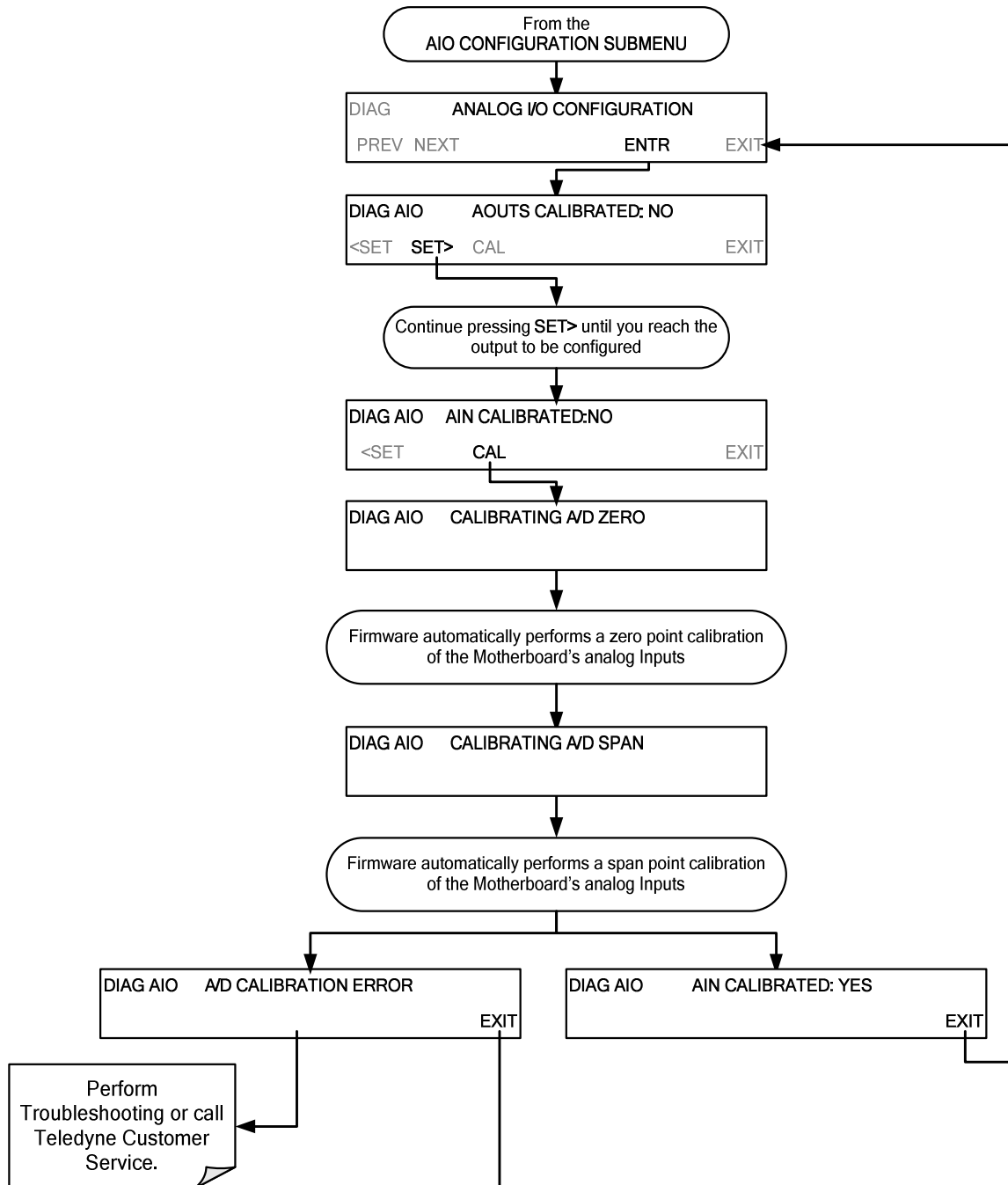

5.8.3.10. ANALOG INPUTS (XIN1...XIN8) OPTION CONFIGURATION

To configure the analyzer’s external analog inputs option, define for each channel:

- gain (number of units represented by 1 volt)
- offset (volts)
- engineering units to be represented in volts (each press of the touchscreen button scrolls the list of alphanumeric characters from A-Z and 0-9)
- whether to display the channel in the Test functions

To access and adjust settings for the external Analog Inputs option channels press:

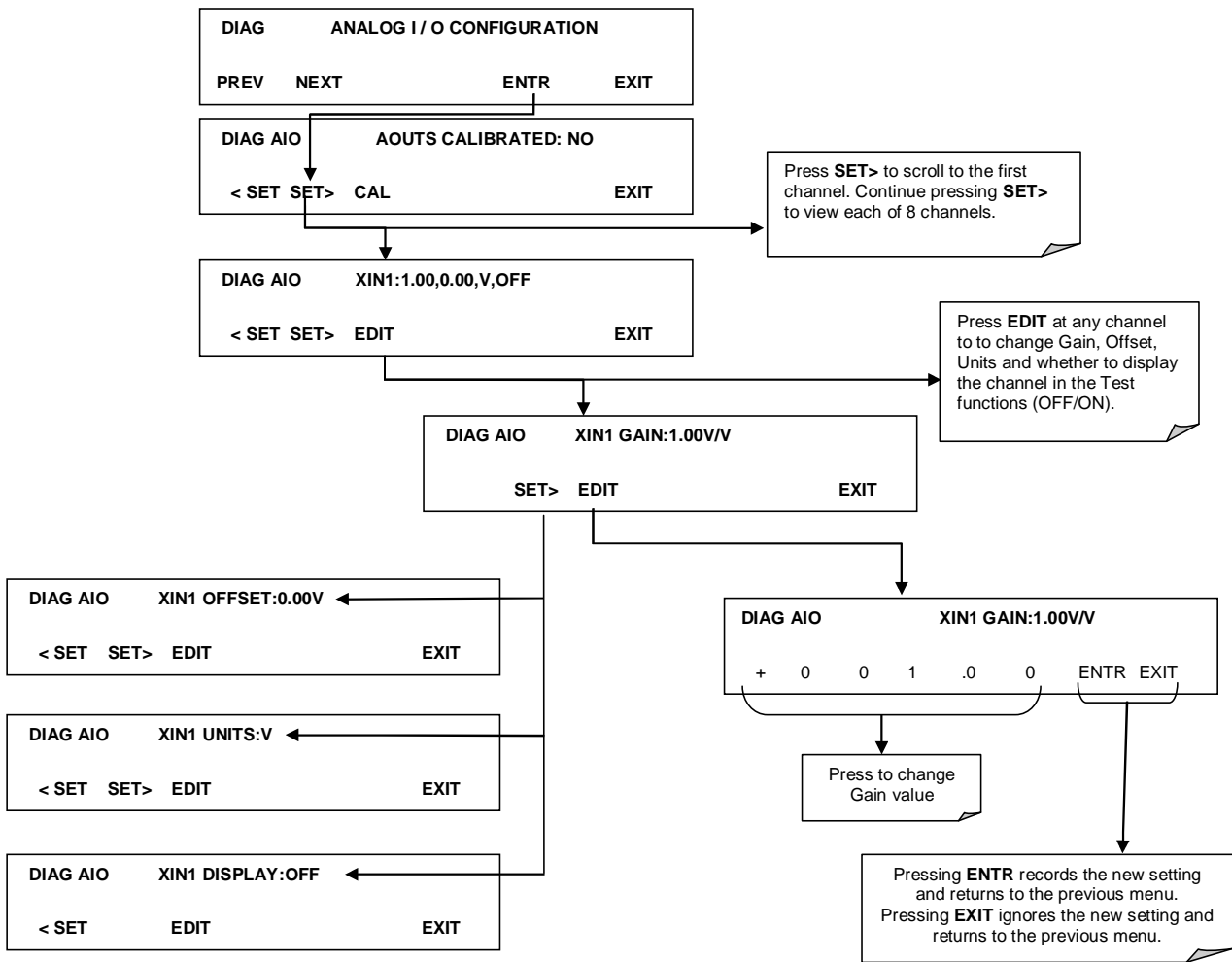
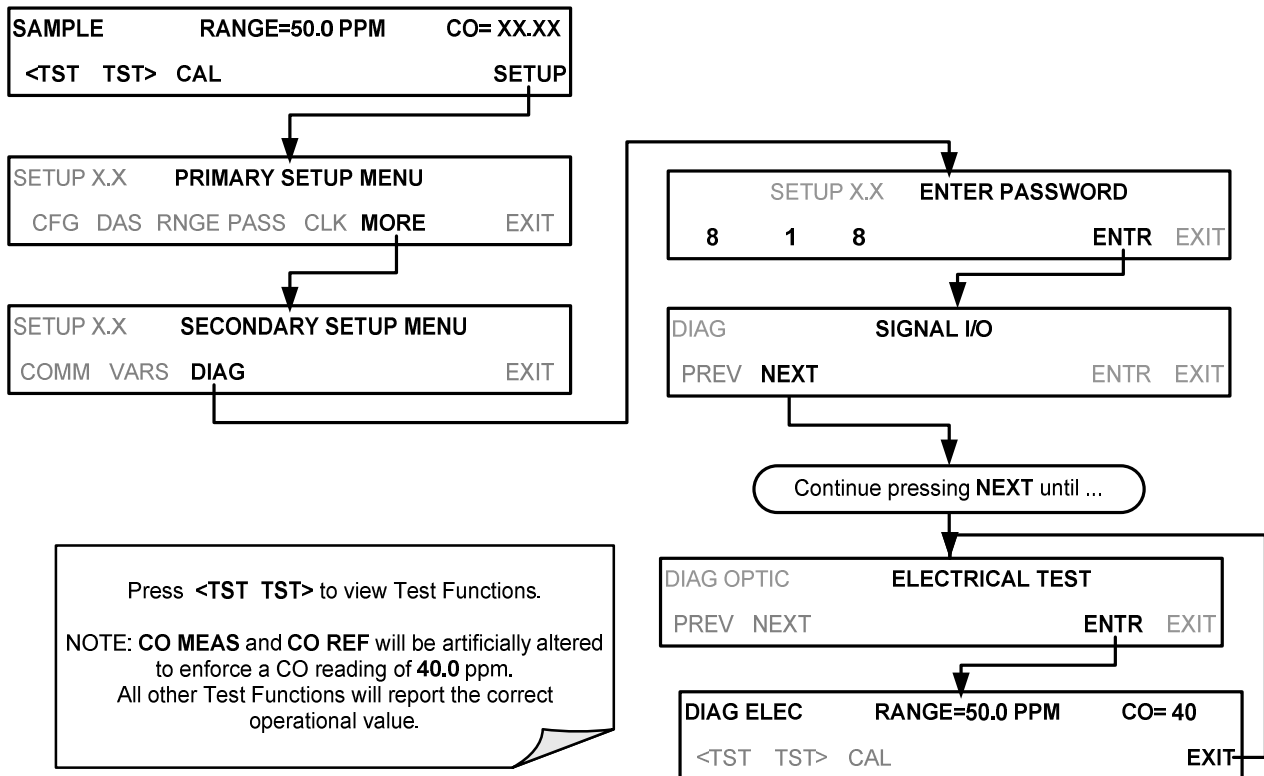

Figure 5-7. DIAG – Analog Inputs (Option) Configuration Menu

5.8.4. ELECTRICAL TEST

The electrical test function creates a current, which substitutes the PMT signal, and feeds it into the preamplifier board. This signal is generated by circuitry on the pre-amplifier board itself and tests the filtering and amplification functions of that assembly along with the A/D converter on the motherboard. It does not test the PMT itself. (See also Section 11.5.7.2).



Note: The above screen(s) show CO concentration displayed. Your instrument will indicate and display N₂O concentration.

5.8.5. DARK CALIBRATION

The dark calibration test interrupts the signal path between the IR photo-detector and the remainder of the sync/demod board circuitry. This allows the instrument to compensate for any voltage levels inherent in the sync/demod circuitry that might affect the calculation of N₂O concentration. For details see Section 9.5.1.

5.8.6. PRESSURE CALIBRATION

A sensor at the exit of the sample chamber continuously measures the pressure of the sample gas. The data are used to compensate the final N₂O concentration calculation for changes in atmospheric pressure and are stored in the CPU's memory as the test function **PRES** (also viewable via the front panel). For details see Section 9.5.2.

5.8.7. FLOW CALIBRATION

The flow calibration allows the user to adjust the values of the sample flow rates as they are displayed on the front panel and reported through COMM ports to match the actual flow rate measured at the sample inlet. This does not change the hardware measurement of the flow sensors, only the software-calculated values. For details see Section 9.5.3.

5.8.8. TEST CHAN OUTPUT

When activated, output channel **A4** can be used in the standard configuration to report one of the test functions viewable from the SAMPLE mode display. (See also Section 11.5.8.2).

5.8.8.1. SELECTING A TEST CHANNEL FUNCTION FOR OUTPUT A4

The test functions available to be reported are listed in Table 5-9:

Table 5-9: Test Channels Functions available on the GFC7002T/GFC7002TU's Analog Output

TEST CHANNEL	DESCRIPTION	ZERO	FULL SCALE *
NONE	<i>TEST CHANNEL IS TURNED OFF.</i>		
N2O MEASURE	The demodulated, peak IR detector output during the measure portion of the GFC Wheel cycle.	0 mV	5000 mV
N2O REFERENCE	The demodulated, peak IR detector output during the reference portion of the GFC Wheel cycle.	0 mV	5000 mV
SAMPLE PRESSURE	The absolute pressure of the Sample gas as measured by a pressure sensor located inside the sample chamber.	0 "Hg	40 "Hg
SAMPLE FLOW	Sample mass flow rate as measured by the flow rate sensor in the sample gas stream.	0 cm ³ /m	1000 cm ³ /m
SAMPLE TEMP	The temperature of the gas inside the sample chamber.	0°C	70°C
BENCH TEMP	Optical bench temperature.	0°C	70°C
WHEEL TEMP	GFC Wheel temperature.	0°C	70°C
O ₂ CELL TEMP ¹	The current temperature of the O ₂ sensor measurement cell.	n	70°C
CHASSIS TEMP	The temperature inside the analyzer chassis.	0°C	70°C
PHT DRIVE	The drive voltage being supplied to the thermoelectric coolers of the IR photo-detector by the Sync/Demod Board.	0 mV	5000 mV
<ul style="list-style-type: none"> • * Maximum test signal value at full scale of test channel output. • ¹ When option installed. 			

Once a function is selected, the instrument not only begins to output a signal on the analog output, but also adds **TEST** to the list of test functions viewable via the front panel display.

To activate the **TEST** Channel and select the **N₂O MEASURE** function, press:

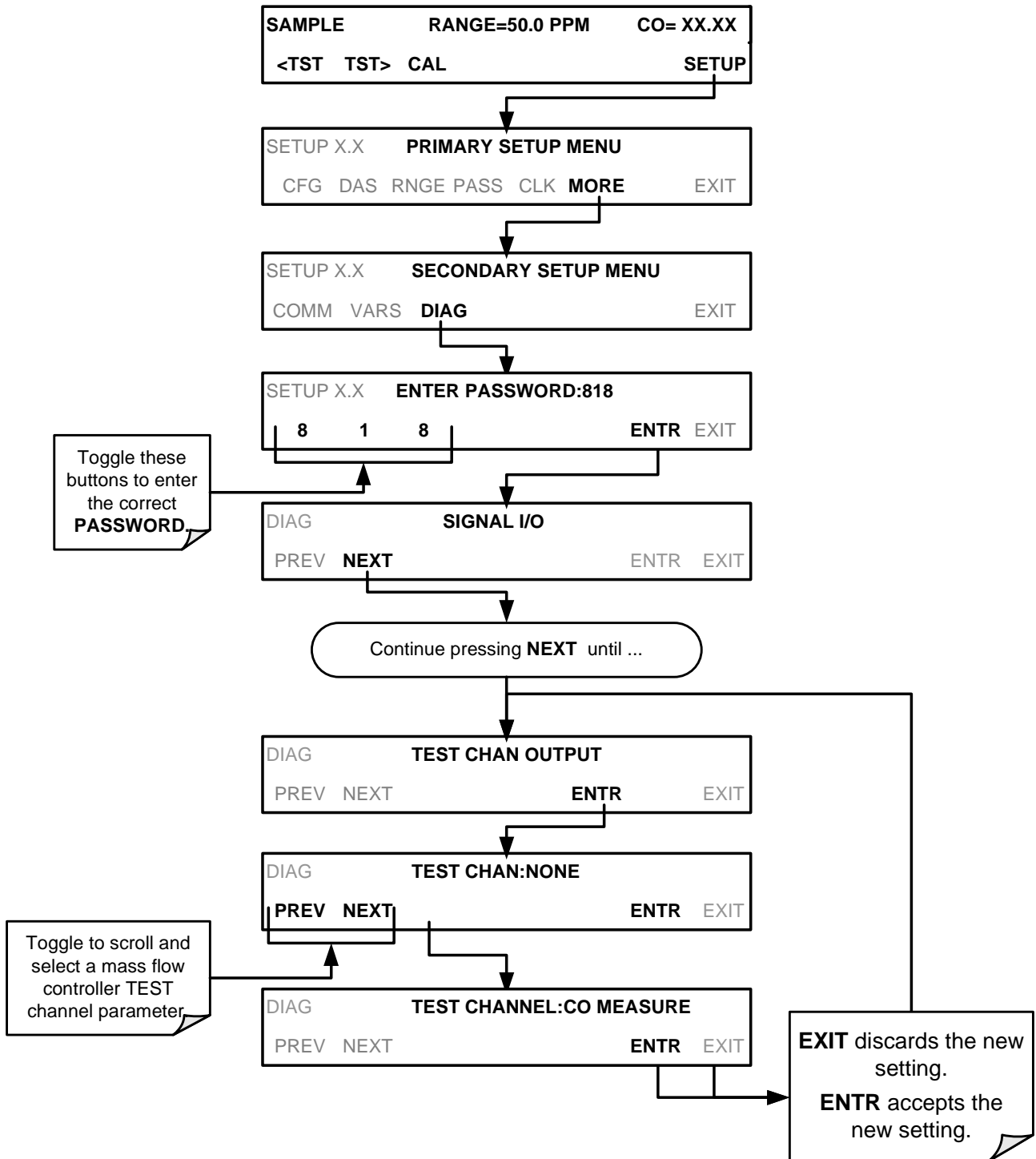

Note: The above screen(s) show CO concentration displayed. Your instrument will indicate and display N₂O concentration.

5.9. SETUP → MORE → ALRM (OPTION): USING THE GAS CONCENTRATION ALARMS

The GFC7002T/GFC7002TU includes two N₂O concentration alarms if OPT 61 is installed on your instrument. Each alarm has a user settable limit, and is associated with a Single Pole Double Throw relay output accessible via the alarm output connector on the instrument's back panel (See Section 3.3.1.4). If the N₂O concentration measured by the instrument rises above that limit, the alarm's status output relay is closed.

The default settings for **ALM1** and **ALM2** are:

Table 5-10: N₂O Concentration Alarm Default Settings

ALARM	STATUS	LIMIT SET POINT ¹
alm1	Disabled	100 ppm
alm2	Disabled	300 ppm

¹Set points listed are for PPM. Should the reporting range units of measure be changed (See Section 5.4.3) the analyzer will automatically scale the set points to match the new range unit setting.

Note

To prevent the concentration alarms from activating during span calibration operations ensure that the CAL or CALS button is pressed prior to introducing span gas into the analyzer.

5.9.1. SETTING THE GFC7002T CONCENTRATION ALARM LIMITS

To enable either of the N₂O concentration alarms and set the limit points, press:

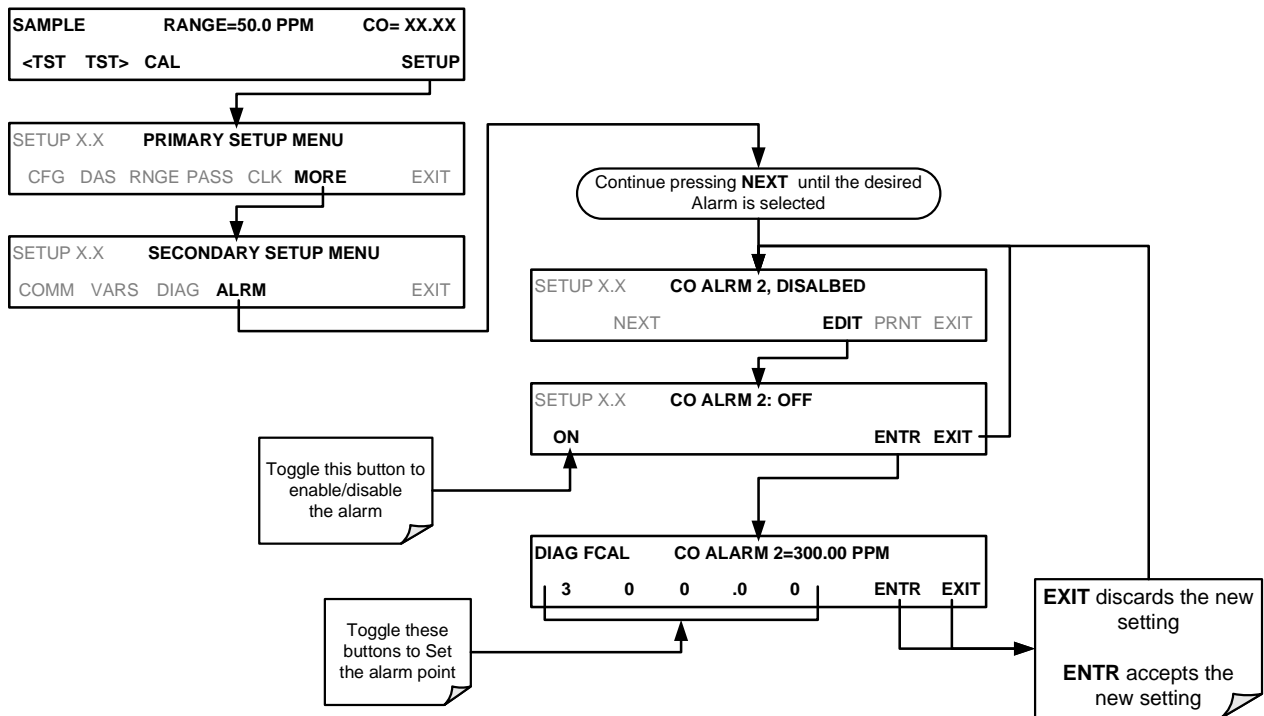

Note: The above screen(s) show CO concentration displayed. Your instrument will indicate and display N₂O concentration.

5.9.2. APR OPTION AND CONFIGURATION

The TAI GFC7002T/TU analyzers are available with the APR option. With this option there are three configurations available which affect how the alarm relays function. They are as follows:

- **RANGE/ZERO Relays:** This Factory Option activates the APR relay features. When turned OFF, the instrument reverts to relays similar to the non-APR instruments. When the APR option is included this configuration will almost always be ON. **Default is ON.**
- **SPAN/ZERO Relay:** The default APR configuration only reports ZERO CAL on relay AL3. When this Factory Option is turned ON, relay AL3 will indicate when either ZERO CAL or SPAN CAL is active. When RANGE/ZERO RELAYS is OFF, this option has no effect. **Default is OFF.**
- **Conc. Alarms:** This Factory Option enables the 2 concentration alarms in the instrument. The relays (if any) which indicate alarms varies depending upon the above factory options (see table). **Default is ON.**

The following table summarizes all the possible Factory Option configurations which affect the relays. The configurations highlighted in grey are of the most interest for APR applications, since RANGE/ZERO RELAYS is typically ON. A dash "-" in the table indicates the option has no effect in this situation.

FACTORY OPTIONS			RELAYS CONFIGURATION			
RANGE/ZERO RELAYS	SPAN/ZERO RELAYS	CONC ALARMS	Relay AL1	Relay AL2	Relay AL3	Relay AL4
OFF	-	OFF	System OK	(off)	(off)	(off)
OFF	-	ON	System OK	conc alarm 1	conc alarm 2	(off)
ON	OFF	OFF	System OK	hi range	zero cal only	(off)
ON	OFF	ON	System OK	hi range	zero cal only	conc alarm 1
ON	ON	OFF	System OK	hi range	span or zero cal	(off)
ON	ON	ON	System OK	hi range	span or zero cal	conc alarm 1

<-- Similar to default non-APR configuration.

<-- Default APR configuration.

6. COMMUNICATIONS SETUP AND OPERATION

This instrument rear panel connections include an Ethernet port, a USB port (option) and two serial communications ports (labeled RS232, which is the COM1 port, and COM2) located on the rear panel (refer to Figure 3-4). These ports give the user the ability to communicate with, issue commands to, and receive data from the analyzer through an external computer system or terminal.

This section provides pertinent information regarding communication equipment, describes the instrument's communications modes, presents configuration instructions for the communications ports, and provides instructions for their use, including communications protocol. Data acquisition is presented in Section 7.

6.1. DATA TERMINAL/COMMUNICATION EQUIPMENT (DTE DCE)

RS-232 was developed for allowing communications between data terminal equipment (DTE) and data communication equipment (DCE). Basic terminals always fall into the DTE category whereas modems are always considered DCE devices. The difference between the two is the pin assignment of the Data Receive and Data Transmit functions.

- DTE devices receive data on pin 2 and transmit data on pin 3.
- DCE devices receive data on pin 3 and transmit data on pin 2.

To allow the analyzer to be used with terminals (DTE), modems (DCE) and computers (which can be either), a switch mounted below the serial ports on the rear panel allows the user to set the RS-232 configuration for one of these two data devices. This switch exchanges the Receive and Transmit lines on RS-232 emulating a cross-over or null-modem cable. The switch has no effect on COM2.

6.2. COMMUNICATION MODES, BAUD RATE AND PORT TESTING

Use the `SETUP>MORE>COMM` menu to configure COM1 (labeled **RS232** on instrument rear panel) and/or COM2 (labeled **COM2** on instrument rear panel) for communication modes, baud rate and/or port testing for correct connection. If using a USB option communication connection, setup requires configuring the COM2 baud rate (Section 6.2.2).

6.2.1. COMMUNICATION MODES

Either of the analyzer's serial ports (**RS232** or **COM2** on rear panel) can be configured to operate in a number of different modes, which are described in Table 6-1. As modes are selected, the analyzer sums the mode ID numbers and displays this combined number on the front panel display. For example, if quiet mode (01), computer mode

(02) and Multidrop-Enabled mode (32) are selected, the analyzer would display a combined **MODE ID** of 35.

Table 6-1: COMM Port Communication Modes

MODE ¹	ID	DESCRIPTION
QUIET	1	Quiet mode suppresses any feedback from the analyzer (such as warning messages) to the remote device and is typically used when the port is communicating with a computer program where such intermittent messages might cause communication problems. Such feedback is still available but a command must be issued to receive them.
COMPUTER	2	Computer mode inhibits echoing of typed characters and is used when the port is communicating with a computer operated control program.
TAI PROTOCOL	16384	Protocol for communication with TAI Valve Boxes.
E, 8, 1	8192	When turned on this mode switches the COMM port settings from <ul style="list-style-type: none"> • NO PARITY; 8 data bits; 1 stop bit to EVEN PARITY; 8 data bits; 1 stop bit.
E, 7, 1	2048	When turned on this mode switches the COM port settings from <ul style="list-style-type: none"> • NO PARITY; 8 DATA BITS; 1 stop bit to EVEN PARITY; 7 DATA BITS; 1 stop bit.
RS-485	1024	Configures the COM2 Port for RS-485 communication. RS-485 mode has precedence over multidrop mode if both are enabled.
SECURITY	4	When enabled, the serial port requires a password before it will respond (see Section 5.5). If not logged on, the only active command is the '?' request for the help screen.
MULTIDROP PROTOCOL	32	Multidrop protocol allows a multi-instrument configuration on a single communications channel. Multidrop requires the use of instrument IDs.
ENABLE MODEM	64	Enables to send a modem initialization string at power-up. Asserts certain lines in the RS-232 port to enable the modem to communicate.
ERROR CHECKING ²	128	Fixes certain types of parity errors at certain installations.
XON/XOFF HANDSHAKE ²	256	Disables XON/XOFF data flow control also known as software handshaking.
HARDWARE HANDSHAKE	8	Enables CTS/RTS style hardwired transmission handshaking. This style of data transmission handshaking is commonly used with modems or terminal emulation protocols as well as by Teledyne Instrument's APICOM software.
HARDWARE FIFO ²	512	Disables the HARDWARE FIFO (First In – First Out). When FIFO is enabled it improves data transfer rate for that COM port.
COMMAND PROMPT	4096	Enables a command prompt when in terminal mode.

¹ Modes are listed in the order in which they appear in the **SETUP → MORE → COMM → COM[1 OR 2] → MODE** menu

² The default setting for this feature is **ON**. Do not disable unless instructed to by TAI's Customer Service personnel.

Communication Modes for each COM port must be configured independently. To turn on or off the communication modes for either COM1 or COM2, access the **SETUP>MORE>[COM1 or COM2]** menu and at the COM1[2] Mode menu press **EDIT**.

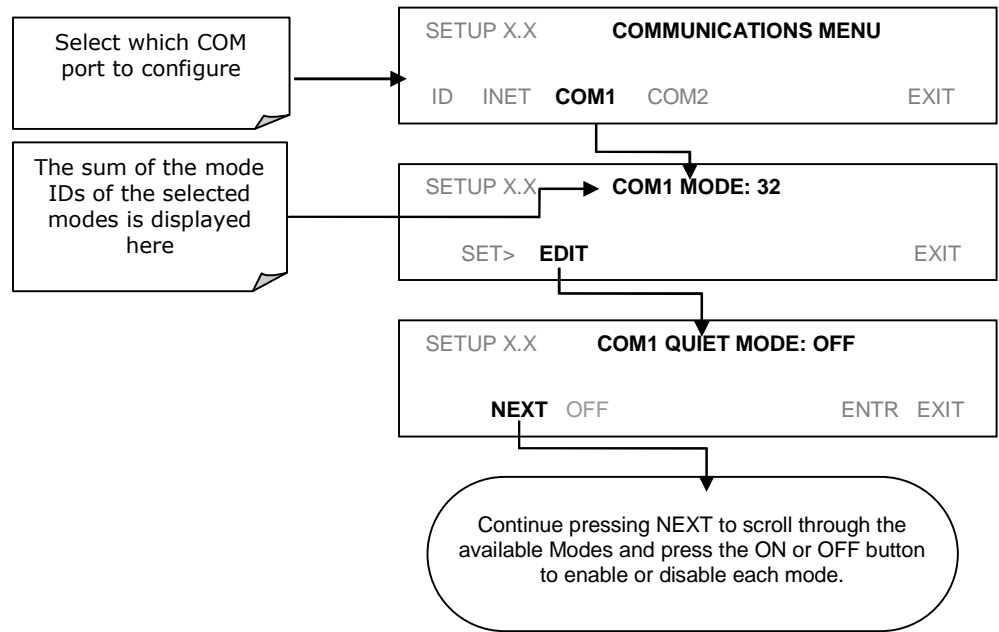

Figure 6-1: COM1[2] – Communication Modes Setup

6.2.2. COM PORT BAUD RATE

To select the baud rate of either COM Port, go to **SETUP>MORE>COMM** and select either COM1 or COM2 as follows (use COM2 to view/match your personal computer baud rate when using the USB port, Section 6.6):

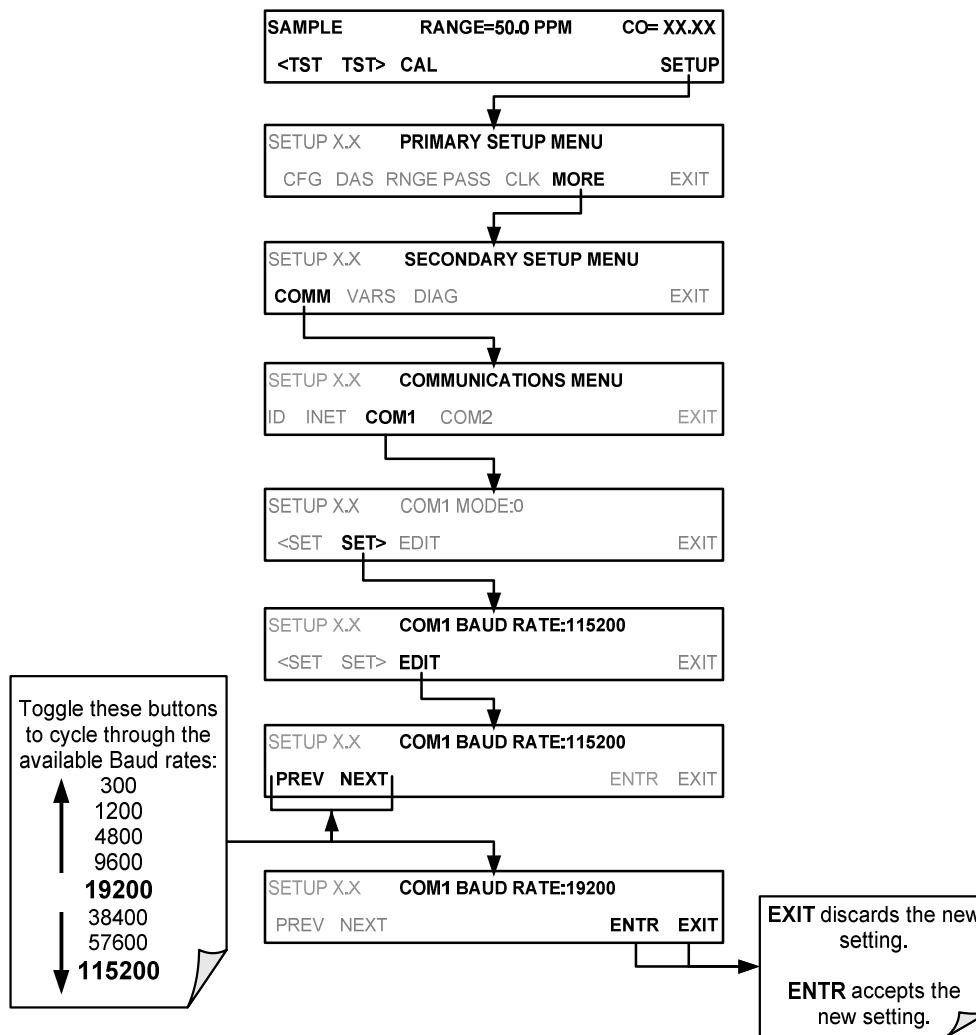

Figure 6-2: COMM Port Baud Rate

Note: The above screen(s) show CO concentration displayed. Your instrument will indicate and display N₂O concentration.

6.2.3. COM PORT TESTING

The serial ports can be tested for correct connection and output in the **COMM** menu. This test sends a string of 256 ‘w’ characters to the selected COM port. While the test is running, the red LED labeled TX for that COM port on the instrument’s rear panel analyzer should flicker.

To initiate the test, access the COMMUNICATIONS Menu (SETUP>MORE>COMM), then press:

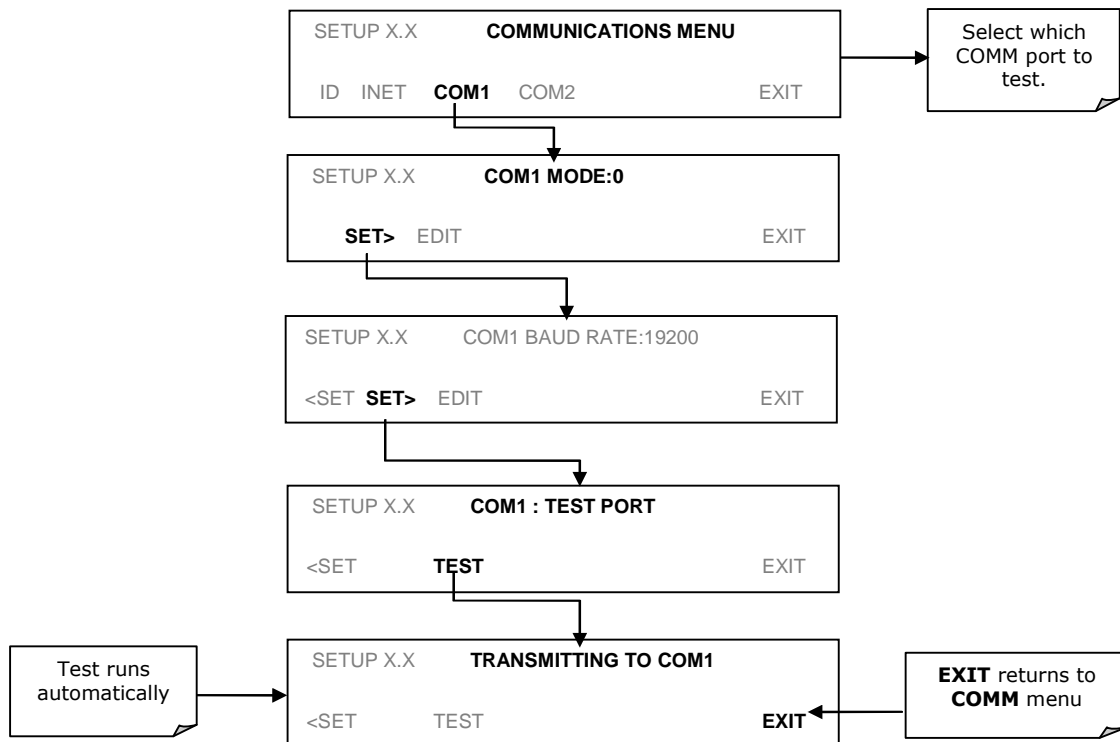

Figure 6-3: COMM – COM1 Test Port

6.3. RS-232

The RS232 and COM2 communications (COMM) ports operate on the RS-232 protocol (default configuration). Possible configurations for these two COMM ports are summarized as follows:

- RS232 port can also be configured to operate in single or RS-232 Multidrop mode (Option 62); refer to Sections 3.3.1.9 and 5.6.2.
- COM2 port can be left in its default configuration for standard RS-232 operation including multidrop, or it can be reconfigured for half-duplex RS-485 operation (please contact the factory for this configuration).

Note that when the rear panel **COM2** port is in use, except for multidrop communication, the rear panel USB port cannot be used. (Alternatively, when the USB port is enabled, **COM2** port cannot be used except for multidrop).

A Code-Activated Switch (CAS), can also be used on either port to connect typically between 2 and 16 send/receive instruments (host computer(s) printers, data loggers, analyzers, monitors, calibrators, etc.) into one communications hub. Contact TAI Sales for more information on CAS systems.

To assist in properly connecting the serial ports to either a computer or a modem, there are activity indicators just above the RS-232 port. Once a cable is connected between the analyzer and a computer or modem, both the red and green LEDs should be on.

- If the lights are not lit, use small switch on the rear panel to switch it between DTE and DCE modes.
- If both LEDs are still not illuminated, make sure the cable properly constructed.

To configure the analyzer's communication ports, use the `SETUP>MORE>COMM` menu. Refer to Section 5.6.4 for initial setup.

6.4. RS-485 (OPTION)

The COM2 port of the instrument's rear panel is set up for RS-232 communication but can be reconfigured for RS-485 communication. Contact Customer Service. If this option was elected at the time of purchase, the rear panel was preconfigured at the factory. Choosing this option disallows use of the USB port.

6.5. ETHERNET

When using the Ethernet interface, the analyzer can be connected to any standard 10BaseT or 100BaseT Ethernet network via low-cost network hubs, switches or routers. The interface operates as a standard TCP/IP device on port 3000. This allows a remote computer to connect through the network to the analyzer using APICOM, terminal emulators or other programs.

The Ethernet cable connector on the rear panel has two LEDs indicating the Ethernet's current operating status.

Table 6-2: Ethernet Status Indicators

LED	FUNCTION
amber (link)	On when connection to the LAN is valid.
green (activity)	Flickers during any activity on the LAN.

The analyzer is shipped with DHCP enabled by default. This allows the instrument to be connected to a network or router with a DHCP server. The instrument will automatically be assigned an IP address by the DHCP server (Section 6.5.2). This configuration is useful for quickly getting an instrument up and running on a network. However, for permanent Ethernet connections, a static IP address should be used. Section 6.5.1 below details how to configure the instrument with a static IP address.

6.5.1. CONFIGURING ETHERNET COMMUNICATION MANUALLY (STATIC IP ADDRESS)

To configure Ethernet communication manually:

1. Connect a cable from the analyzer’s Ethernet port to a Local Area Network (LAN) or Internet port.
2. From the analyzer’s front panel touchscreen, access the Communications Menu (SETUP>MORE>COMM).
3. Enter the Ethernet menu (INET), follow the setup sequence as shown in Figure 6-4, and edit the Instrument and Gateway IP addresses and Subnet Mask to the desired settings.

Alternatively, from the computer, enter the same information through an application such as HyperTerminal.

Table 6-3 shows the default Ethernet configuration settings.

Table 6-3: LAN/Internet Default Configuration Properties

PROPERTY	DEFAULT STATE	DESCRIPTION
DHCP	ON	This displays whether the DHCP is turned ON or OFF. Press EDIT and toggle ON for automatic configuration after first consulting network administrator.
INSTRUMENT IP ADDRESS		This string of four packets of 1 to 3 numbers each (e.g. 192.168.76.55.) is the address of the analyzer itself.
GATEWAY IP ADDRESS	0.0.0.0	Can only be edited when DHCP is set to OFF. A string of numbers very similar to the Instrument IP address (e.g. 192.168.76.1.) that is the address of the computer used by your LAN to access the Internet.
SUBNET MASK	0.0.0.0	Can only be edited when DHCP is set to OFF. Also a string of four packets of 1 to 3 numbers each (e.g. 255.255.252.0) that identifies the LAN to which the device is connected. All addressable devices and computers on a LAN must have the same subnet mask. Any transmissions sent to devices with different subnets are assumed to be outside of the LAN and are routed through the gateway computer onto the Internet.
TCP PORT ¹	3000	This number defines the terminal control port by which the instrument is addressed by terminal emulation software, such as Internet or Teledyne’s APICOM.
HOST NAME	[initially blank]	The name by which your analyzer will appear when addressed from other computers on the LAN or via the Internet. To change, see Section 6.5.3.

¹ Do not change the setting for this property unless instructed to by Teledyne Customer Service personnel.

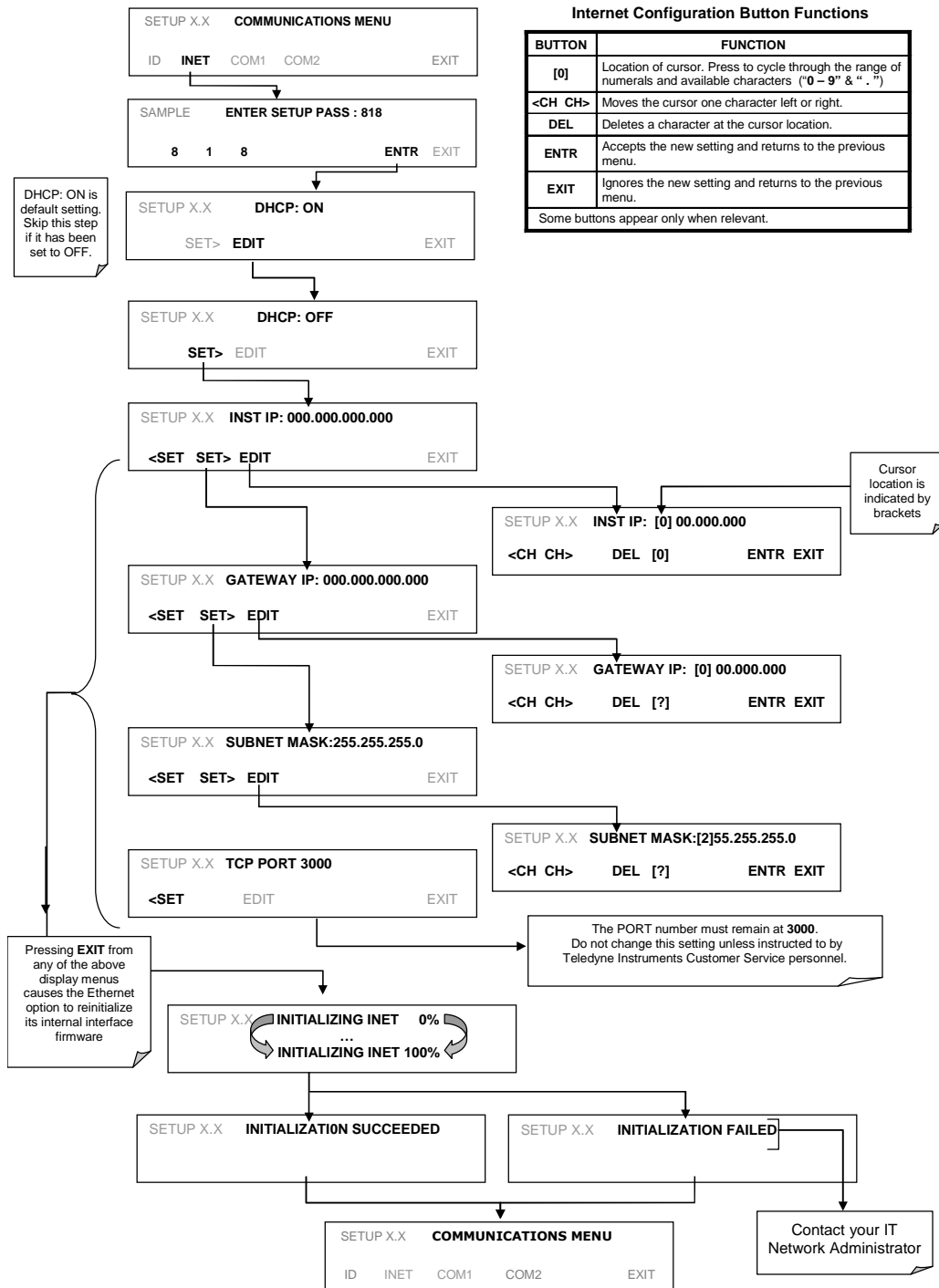

Figure 6-4: COMM – LAN / Internet Manual Configuration

6.5.2. CONFIGURING ETHERNET COMMUNICATION USING DYNAMIC HOST CONFIGURATION PROTOCOL (DHCP)

The default Ethernet setting is DHCP.

1. See your network administrator to affirm that your network server is running DHCP.

- Access the Communications Menu (SETUP>MORE>COMM) and follow the setup sequence as shown in Figure 6-5.

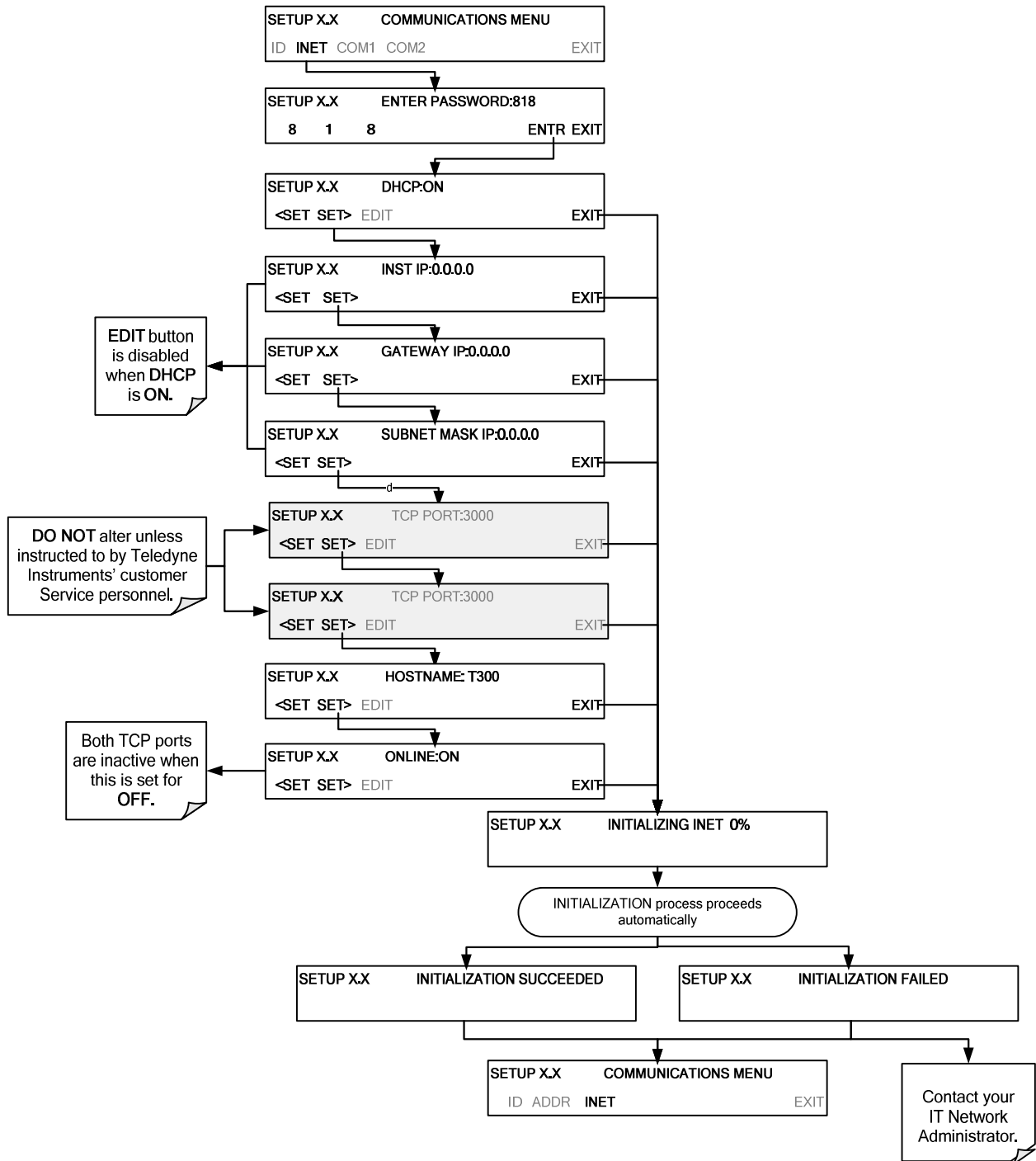
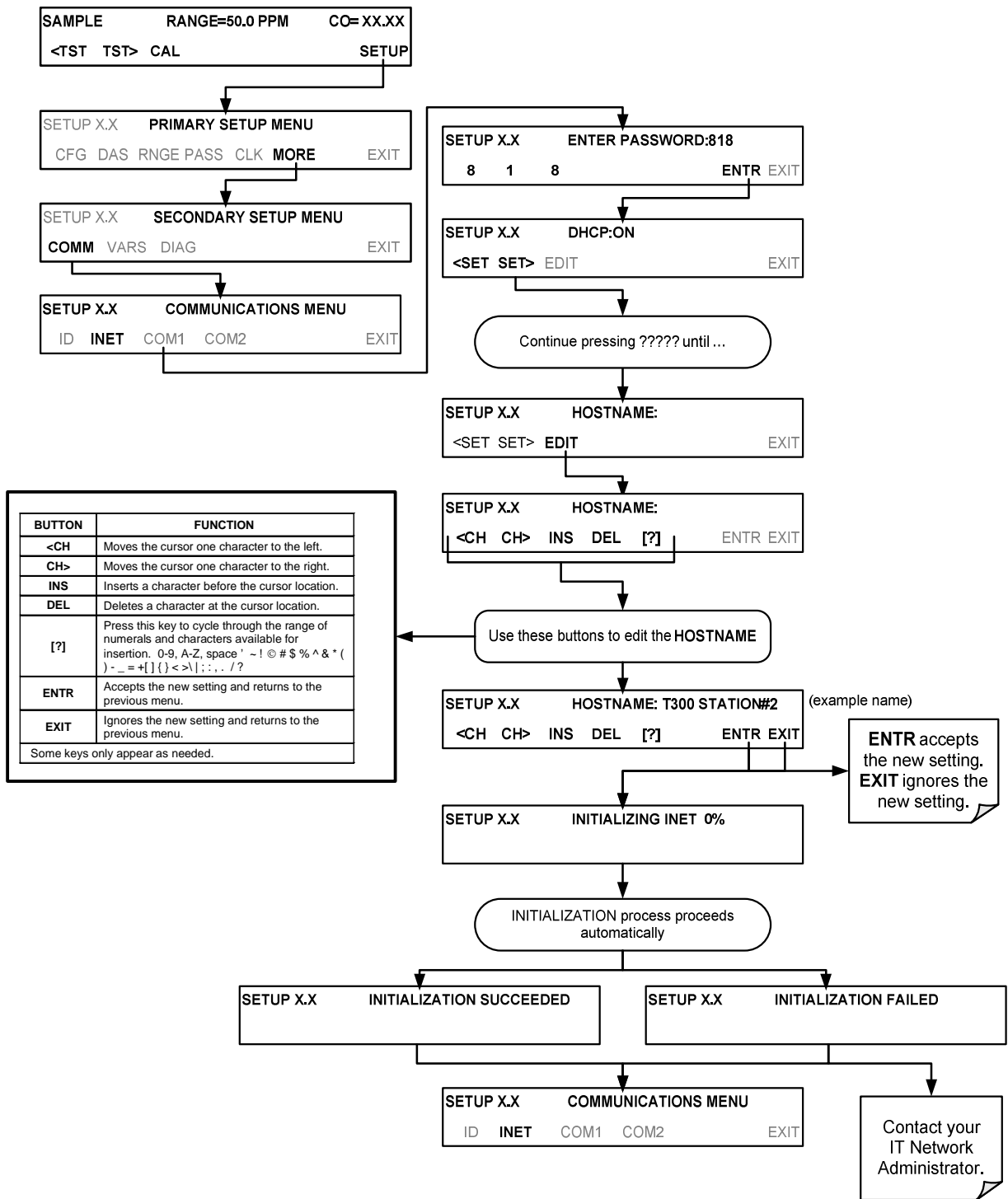

Figure 6-5 : COMM – LAN / Internet Automatic Configuration (DHCP)

6.5.3. CHANGING THE ANALYZER’S HOSTNAME

The **HOSTNAME** is the name by which the analyzer appears on your network. The default name for all Teledyne’s GFC7002T analyzers is **GFC7002T**. To change this

name (particularly if you have more than one GFC7002T/GFC7002TU Analyzer on your network), press:



Note: The above screen(s) show CO concentration displayed. Your instrument will indicate and display N₂O concentration.

6.6. USB PORT (OPTION) FOR REMOTE ACCESS

The analyzer can be operated through a personal computer by downloading the Teledyne USB driver and directly connecting their respective USB ports.

1. Install the Teledyne T-Series USB driver on your computer, downloadable from the TAI website under Help Center>Software Downloads (www.teledyne-api.com/software).
2. Run the installer file: “TAPIVCPInstaller.exe”

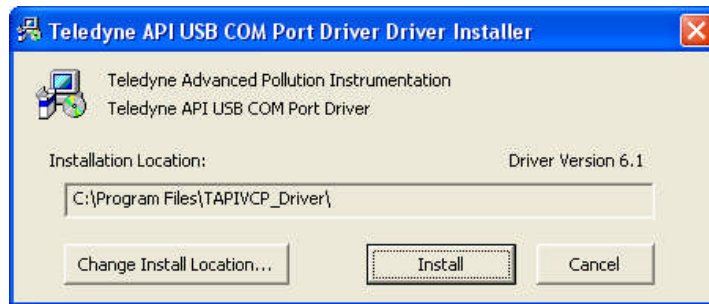

3. Connect the USB cable between the USB ports on your personal computer and your analyzer. The USB cable should be a Type A – Type B cable, commonly used as a USB printer cable.
4. Determine the Windows XP Com Port number that was automatically assigned to the USB connection. (Start → Control Panel → System → Hardware → Device Manager). This is the com port that should be set in the communications software, such as APIcom or Hyperterminal.

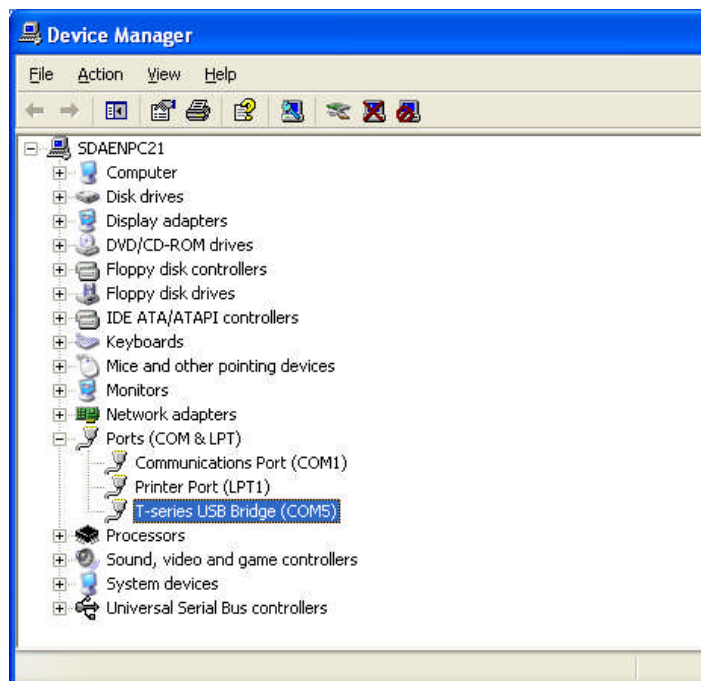

Refer to the Quick Start (*Direct Cable Connection*) section of the Teledyne APIcom Manual, PN 07463.

- In the instrument's SETUP>MORE>COMM>COM2 menu, make the following settings:

Baud Rate: 115200
 COM2 Mode Settings:
 Quiet Mode ON
 Computer Mode ON
 E,8,1 MODE OFF
 E,7,1 MODE OFF
 RS-485 MODE OFF
 SECURITY MODE OFF
 MULTIDROP MODE OFF
 ENABLE MODEM OFF
 ERROR CHECKING ON
 XON/XOFF HANDSHAKE OFF
 HARDWARE HANDSHAKE OFF
 HARDWARE FIFO ON
 COMMAND PROMPT OFF

- Next, configure your communications software, such as APIcom. Use the COM port determined in Step 4 and the baud rate set in Step 5. The figures below show how these parameters would be configured in the Instrument Properties window in APIcom when configuring a new instrument. See the APIcom manual (PN 07463) for more details.

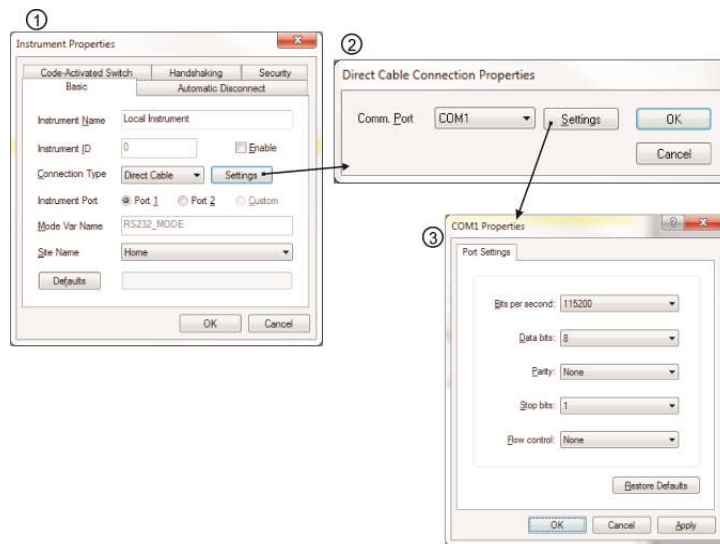

Note

- **USB configuration requires that the baud rates of the instrument and the PC match; check the PC baud rate and change if needed.**
- **Using the USB port disallows use of the rear panel COM2 port except for multidrop communication.**

7. DATA ACQUISITION SYSTEM (DAS) AND APICOM

The GFC7002T/GFC7002TU Analyzer contains a flexible and powerful, Internal Data Acquisition System (DAS) that enables the analyzer to store concentration and calibration data as well as a host of diagnostic parameters. The DAS of the GFC7002T/GFC7002TU can store up to about one million data points, which can, depending on individual configurations, cover days, weeks or months of valuable measurements. The data is stored in non-volatile memory and is retained even when the instrument is powered off. Data is stored in plain text format for easy retrieval and use in common data analysis programs (such as spreadsheet-type programs).

The DAS is designed to be flexible, users have full control over the type, length and reporting time of the data. The DAS permits users to access stored data through the instrument's front panel or its communication ports.

The principal use of the DAS is logging data for trend analysis and predictive diagnostics, which can assist in identifying possible problems before they affect the functionality of the analyzer. The secondary use is for data analysis, documentation and archival in electronic format.

To support the DAS functionality, TAI offers APICOM, a program that provides a visual interface for remote or local setup, configuration and data retrieval of the DAS. The APICOM manual, which is included with the program, contains a more detailed description of the DAS structure and configuration, which is briefly described in this manual.

The GFC7002T/GFC7002TU is configured with a basic DAS configuration, which is enabled by default. New data channels are also enabled by default at their creation, but all channels may be turned off for later or occasional use.

The green SAMPLE LED on the instrument front panel, which indicates the analyzer status, also indicates certain aspects of the DAS status:

Table 7-1: Front Panel LED Status Indicators for DAS

LED STATE	DAS STATUS
Off	System is in calibration mode. Data logging can be enabled or disabled for this mode. Calibration data are typically stored at the end of calibration periods, concentration data are typically not sampled, diagnostic data should be collected.
Blinking	Instrument is in hold-off mode, a short period after the system exits calibrations. DAS channels can be enabled or disabled for this period. Concentration data are typically disabled whereas diagnostic should be collected.
On	Sampling normally.

Note

DAS operation is suspended whenever its configuration is edited using the analyzer's front panel and therefore data may be lost. To prevent such data loss, it is recommended to use the APICOM graphical user interface for DAS changes.

Please be aware that all stored data will be erased if the analyzer's disk-on-module or CPU board is replaced or if the configuration data stored there is reset.

Note

The DAS can be disabled only by disabling or deleting its individual data channels.

7.1. DAS STRUCTURE

The DAS is designed around the feature of a “record”. A record is a single data point. The type of data recorded in a record is defined by two properties:

PARAMETER type that defines the kind of data to be stored (e.g. the average of gas concentrations measured with three digits of precision). See Section 7.1.6.

A **TRIGGER** event that defines when the record is made (e.g. timer; every time a calibration is performed, etc.). See Section 7.1.5.

The specific **PARAMETERS** and **TRIGGER** events that describe an individual record are defined in a construct called a **DATA CHANNEL** (see Section 7.1.1). Each data channel is related one or more parameters with a specific trigger event and various other operational characteristics related to the records being made (e.g. the channels name, number or records to be made, time period between records, whether or not the record is exported via the analyzer's RS-232 port, etc.).

7.1.1. DAS DATA CHANNELS

The key to the flexibility of the DAS is its ability to store a large number of combinations of triggering events and data parameters in the form of data channels. Users may create up to 50 data channels and each channel can contain one or more parameters. For each channel, the following are selected:

- One triggering event is selected.
- Up to 50 data parameters, which can be shared between channels.
- Several other properties that define the structure of the channel and allow the user to make operational decisions regarding the channel.

Table 7-2: DAS Data Channel Properties

PROPERTY	DESCRIPTION	DEFAULT SETTING	SETTING RANGE
NAME	The name of the data channel.	"NONE"	Up to 6 letters or digits ¹ .
TRIGGERING EVENT	The event that triggers the data channel to measure and store the datum.	ATIMER	Any available event (see Appendix A-5).
NUMBER AND LIST OF PARAMETERS	A User-configurable list of data types to be recorded in any given channel.	1 (COMEAS)	Any available parameter (see Appendix A-5).
REPORT PERIOD	The amount of time between each channel data point.	000:01:00 (1 hour)	000:00:01 to 366:23:59 (Days:Hours:Minutes)
NUMBER OF RECORDS	The number of reports that will be stored in the data file. Once the limit is exceeded, the oldest data is over-written.	100	1 to 1 million, limited by available storage space.
RS-232 REPORT	Enables the analyzer to automatically report channel values to the RS-232 ports.	OFF	OFF or ON
CHANNEL ENABLED	Enables or disables the channel. Allows a channel to be temporarily turned off without deleting it.	ON	OFF or ON
CAL HOLD OFF	Disables sampling of data parameters while instrument is in calibration mode ² .	OFF	OFF or ON

¹ More with APICOM, but only the first six are displayed on the front panel.

² When enabled records are not recorded until the DAS HOLD OFF period is passed after calibration mode. DAS HOLD OFF SET in the **VAR**S menu (see Section 7.1.11).

7.1.2. DEFAULT DAS CHANNELS

A set of default Data Channels has been included in the analyzer's software for logging N₂O concentration and certain predictive diagnostic data. These default channels include but are not limited to:

- **CONC:** Samples N₂O concentration at one minute intervals and stores an average every hour with a time and date stamp. Readings during calibration and calibration hold off are not included in the data.
- By default, the last 800 hourly averages are stored.
- **PNUMTC:** Collects sample flow and sample pressure data at five-minute intervals and stores an average once a day with a time and date stamp. This data is useful for monitoring the condition of the critical flow orifice (sample flow) and the sample filter (clogging indicated by a drop in sample pressure) over time to predict when maintenance will be required.
- The last 360 daily averages (about 1 year) are stored.
- **CALDAT:** Logs new slope and offset of N₂O measurements every time a zero or span calibration is performed and the result changes the value of the slope (triggering event: **SLPCHG**). The N₂O stability data to evaluate if the calibration value was stable are also stored.
- This data channel will store data from the last 200 calibrations and can be used to document analyzer calibration and is useful in the detection of the in slope and offset (instrument response) when performing predictive diagnostics as part of a regular maintenance schedule.
- The CALDAT channel collects data based on events (e.g. a calibration operation) rather than a timed interval and therefore does not represent any specific length of

time. As with all data channels, a date and time stamp is recorded for every logged data point.

These default Data Channels can be used as they are, or they can be customized from the front panel to fit a specific application. They can also be deleted to make room for custom user-programmed Data Channels.

Appendix A-5 lists the firmware-specific DAS configuration in plain-text format. This text file can either be loaded into APICOM and then modified and uploaded to the instrument or can be copied and pasted into a terminal program to be sent to the analyzer.

IMPORTANT

IMPACT ON READINGS OR DATA

Sending a DAS configuration to the analyzer through its COM ports will replace the existing configuration and will delete all stored data. Back up any existing data and the DAS configuration before uploading new settings.

Triggering Events and Data Parameters/Functions for these default channels are:

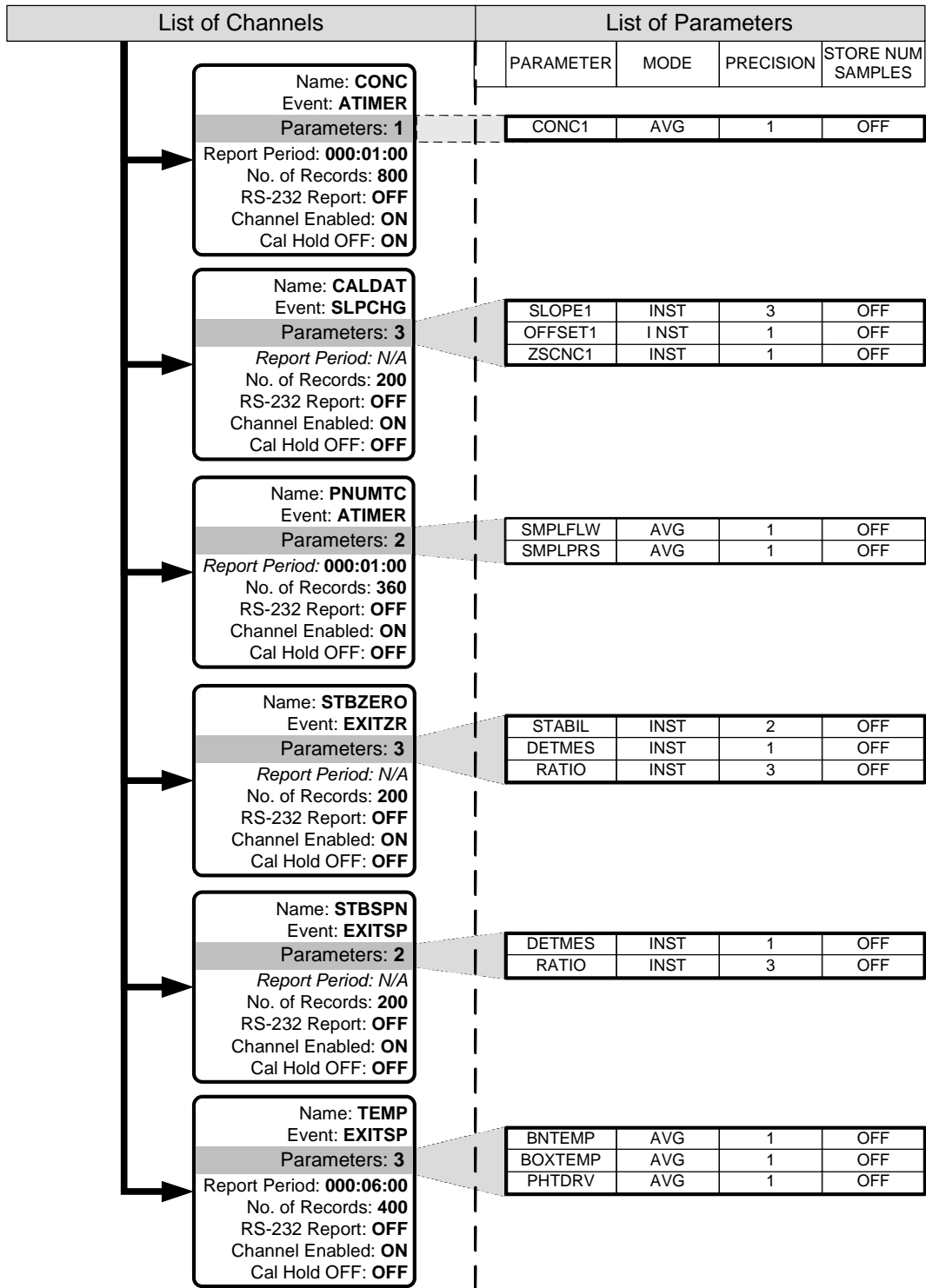
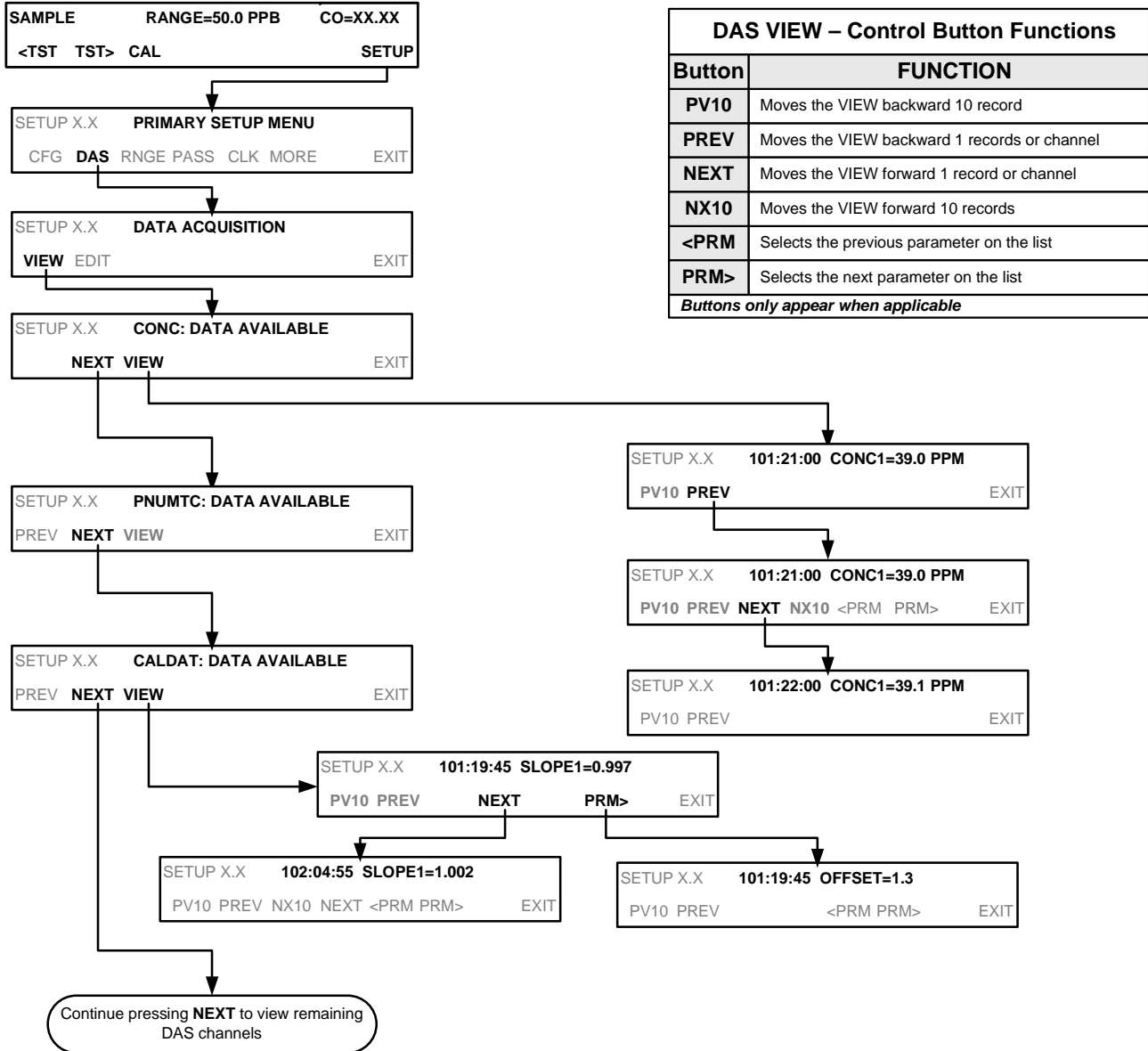

Figure 7-1: Default DAS Channel Setup

7.1.3. VIEWING DAS CHANNELS AND INDIVIDUAL RECORDS

DAS data and settings can be viewed on the front panel through the following buttonstroke sequence.



Note: The above screen(s) show CO concentration displayed. Your instrument will indicate and display N₂O concentration.

7.1.4. EDITING DAS CHANNELS

DAS configuration is most conveniently done through the APICOM remote control program. The following list of button strokes shows how to edit the DAS using the front panel.

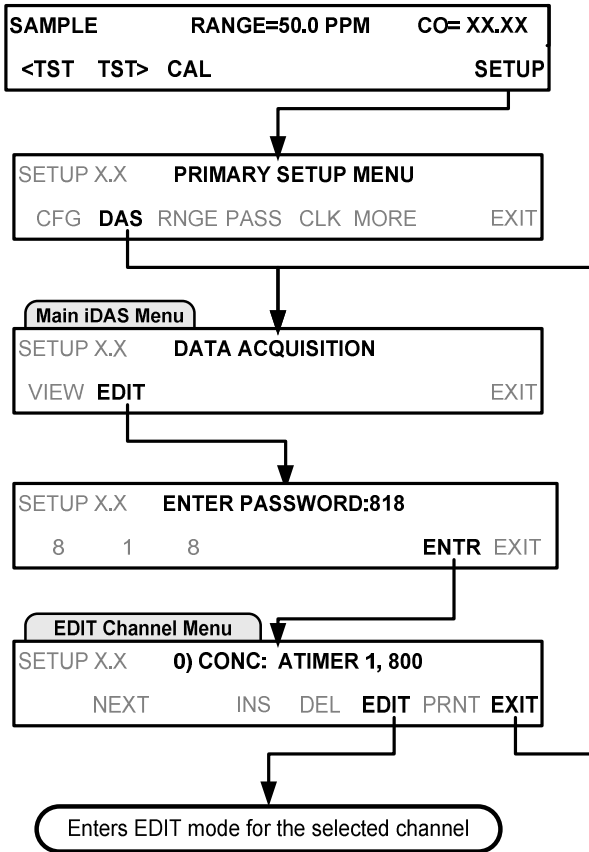

DAS EDIT – Control Button Functions	
Button	FUNCTION
PREV	Selects the previous data channel in the list
NEXT	Selects the next data channel in the list
INS	Inserts a new data channel into the list BEFORE the selected channel
DEL	Deletes the currently selected data channel
EDIT	Enters EDIT mode
PRINT	Exports the configuration of all data channels to the RS-232 interface
<i>Buttons only appear when applicable.</i>	

Note: The above screen(s) show CO concentration displayed. Your instrument will indicate and display N₂O concentration.

When editing the data channels, the top line of the display indicates some of the configuration parameters.

For example, the display line:

0) CONC: ATIMER, 1, 800

Translates to the following configuration:

- Channel No.:** 0
- NAME:** CONC
- TRIGGER EVENT:** ATIMER
- PARAMETERS:** One parameter is included in this channel
- EVENT:** This channel is set up to store 800 records.

7.1.4.1. EDITING DAS DATA CHANNEL NAMES

To edit the name of a DAS data channel, follow the instruction shown in Section 7.1.4.1, then press:

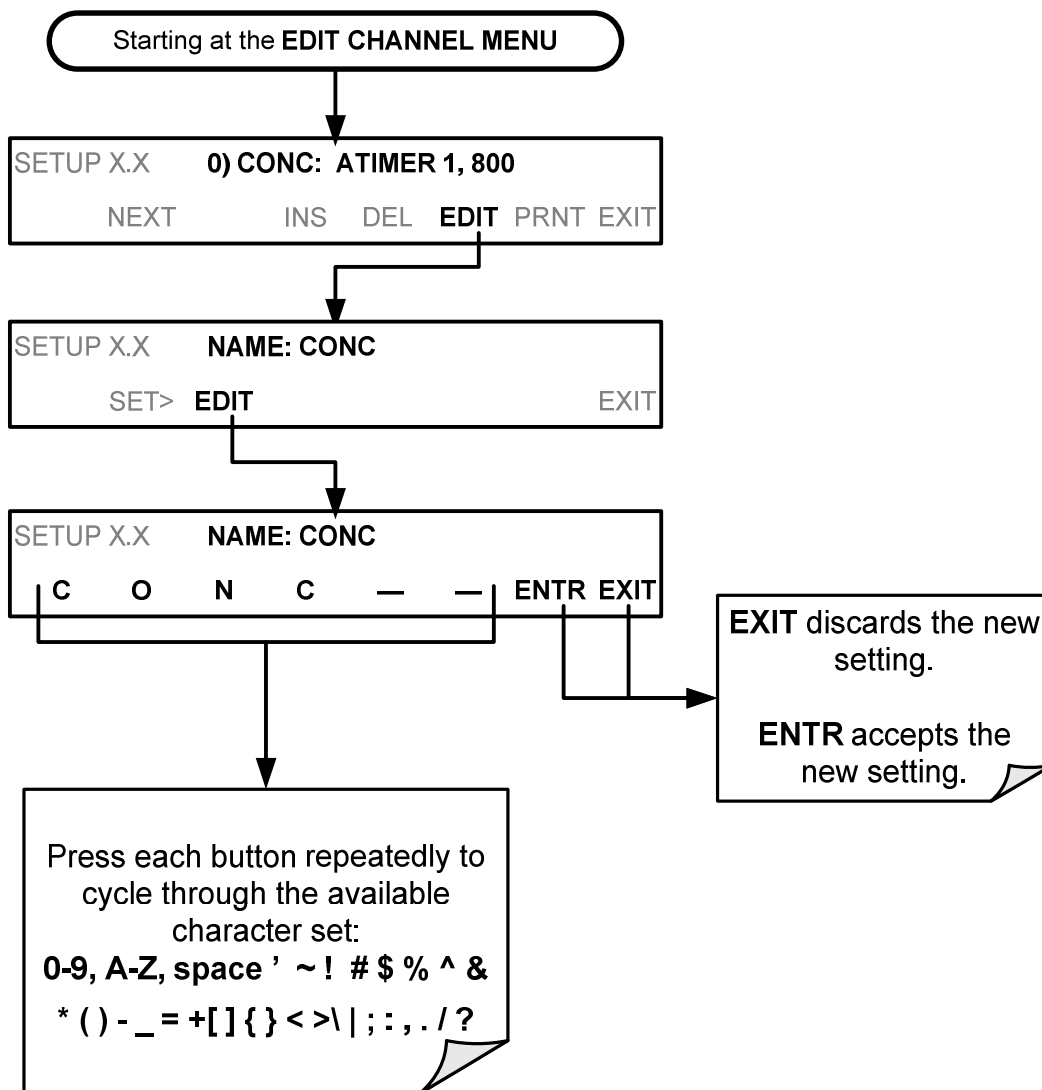

7.1.5. EDITING DAS TRIGGERING EVENTS

Triggering events define when and how the DAS records a measurement of any given data channel. Triggering events are firmware-specific and are listed in Appendix A-5. The most commonly used triggering events are:

- **ATIMER:** Sampling at regular intervals specified by an automatic timer. Most trending information is usually stored at such regular intervals, which can be instantaneous or averaged.
- **EXITZR, EXITSP, and SLPCHG** (exit zero, exit span, slope change): Sampling at the end of (irregularly occurring) calibrations or when the response slope changes. These triggering events create instantaneous data points, e.g., for the new slope and offset (concentration response) values at the end of a calibration. Zero and slope values are valuable to monitor response drift and to document when the instrument was calibrated.
- **WARNINGS:** Some data may be useful when stored if one of several warning messages appears such as **WTEMPW** (GFC Wheel temperature warning). This is helpful for troubleshooting by monitoring when a particular warning occurs.

To edit the list of data parameters associated with a specific data channel, follow the instruction shown in Section 7.1.4 then press:

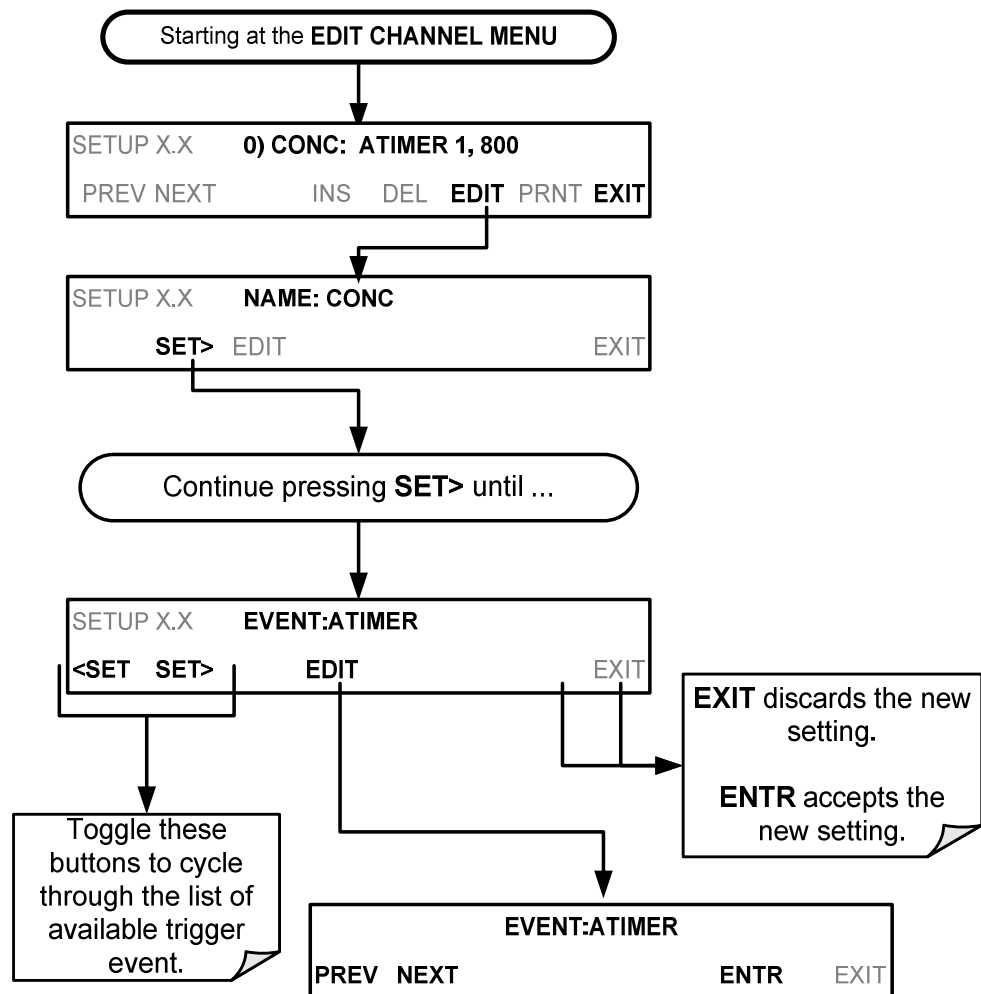

7.1.6. EDITING DAS PARAMETERS

Data parameters are types of data that may be measured and stored by the DAS. For each analyzer model, the list of available data parameters is different, fully defined and not customizable. Appendix A-5 lists firmware specific data parameters for the GFC7002T/GFC7002TU. DAS parameters include things like N₂O concentration measurements, temperatures of the various heaters placed around the analyzer, pressures and flows of the pneumatic subsystem and other diagnostic measurements as well as calibration data such as stability, slope and offset.

Most data parameters have associated measurement units, such as mV, ppb, cm³/min, etc., although some parameters have no units (e.g. **SLOPE**). With the exception of concentration readings, none of these units of measure can be changed. To change the units of measure for concentration readings, see Section 5.4.4.

Note

DAS does not keep track of the unit (e.g., PPM, PPB, etc.) of each concentration value and DAS data files may contain concentrations in more than one type of unit if the unit was changed during data acquisition.

Each data parameter has user-configurable functions that define how the data are recorded (refer to Table 7-3).

Table 7-3: DAS Data Parameter Functions

FUNCTION	EFFECT
PARAMETER	Instrument-specific parameter name.
SAMPLE MODE	INST: Records instantaneous reading. AVG: Records average reading during reporting interval. SDEV: Records the standard deviation of the data points recorded during the reporting interval. MIN: Records minimum (instantaneous) reading during reporting interval. MAX: Records maximum (instantaneous) reading during reporting interval.
PRECISION	0 to 4: Sets the number of digits to the right decimal point for each record. Example: Setting 4 ; " 399.9865 PPB " Setting 0 ; " 400 PPB "
STORE NUM SAMPLES	OFF: Stores only the average (default). ON: Stores the average and the number of samples in used to compute the value of the parameter. This property is only useful when the AVG sample mode is used. Note that the number of samples is the same for all parameters in one channel and needs to be specified only for one of the parameters in that channel.

Users can specify up to 50 parameters per data channel (the GFC7002T/GFC7002TU provides about 40 parameters). However, the number of parameters and channels is ultimately limited by available memory.

Data channels can be edited individually from the front panel without affecting other data channels. However, when editing a data channel, such as during adding, deleting or editing parameters, all data for that particular channel will be lost, because the DAS can store only data of one format (number of parameter columns, etc.) for any given channel. In addition, a DAS configuration can only be uploaded remotely as an entire set of channels. Hence, remote update of the DAS will always delete all current channels and stored data.

To modify, add or delete a parameter, follow the instruction shown in Section 7.1.4 then press:

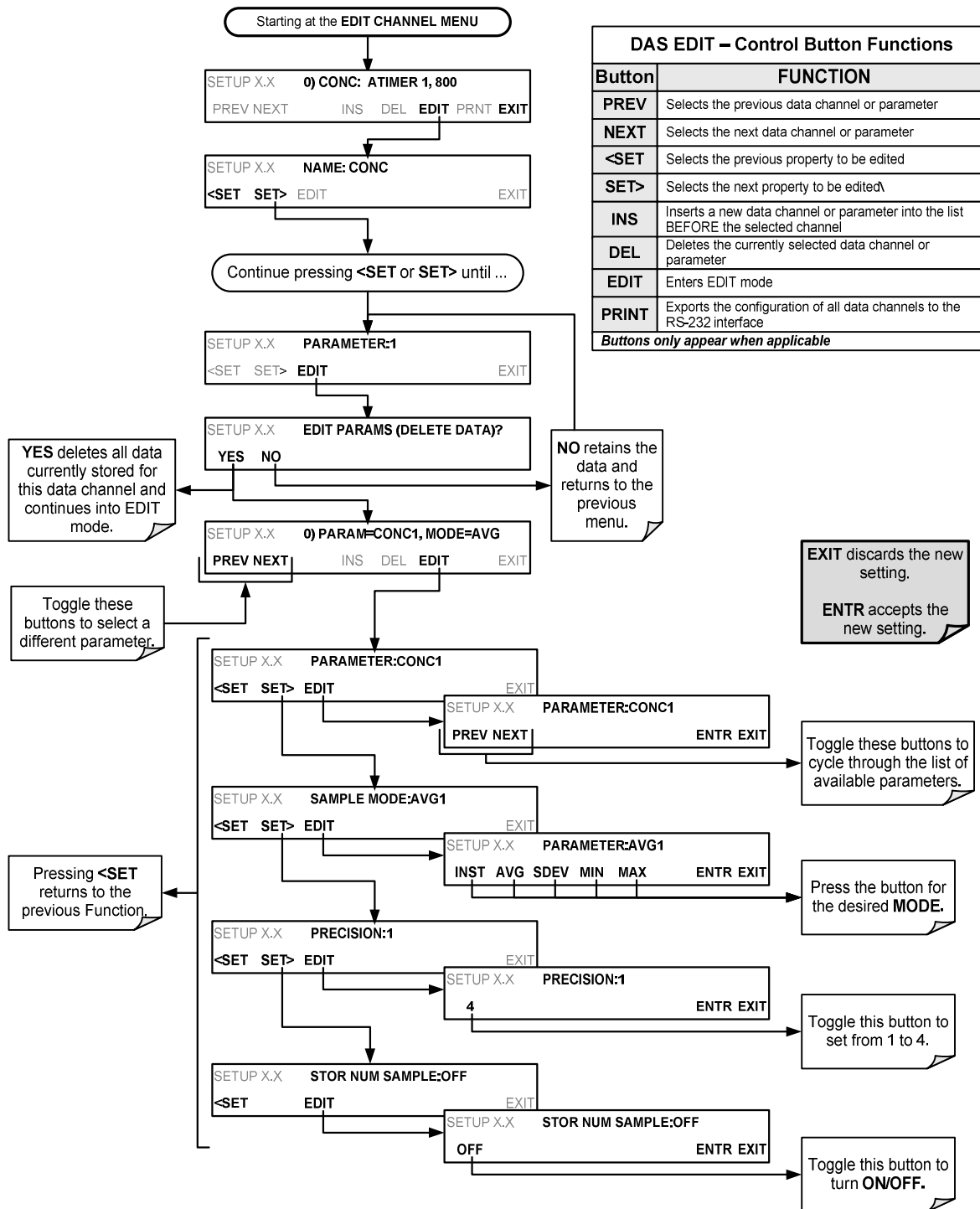

Note

When the STORE NUM SAMPLES feature is turned on, the instrument will store how many measurements were used to compute the AVG, SDEV, MIN or MAX value but not the actual measurements themselves.

7.1.7. SAMPLE PERIOD AND REPORT PERIOD

The DAS defines two principal time periods by which sample readings are taken and permanently recorded: Sample and Report periods.

- SAMPLE PERIOD:** Determines how often DAS temporarily records a sample reading of the parameter in volatile memory. **SAMPLE PERIOD** is only used when the DAS parameter's sample mode is set for **AVG**, **SDEV**, **MIN** or **MAX**.

The **SAMPLE PERIOD** is set to one minute by default and generally cannot be accessed from the standard DAS front panel menu, but is available via the instrument's communication ports by using APICOM or the analyzer's standard serial data protocol.

- REPORT PERIOD:** Sets how often the sample readings stored in volatile memory are processed, (e.g. average, minimum or maximum are calculated) and the results stored permanently in the instrument's Disk-on-Module as well as transmitted via the analyzer's communication ports. The Report Period may be set from the front panel. If the INST sample mode is selected the instrument stores and reports an instantaneous reading of the selected parameter at the end of the chosen report period.

To define the **REPORT PERIOD**, follow the instruction shown in Section 7.1.4 then press:

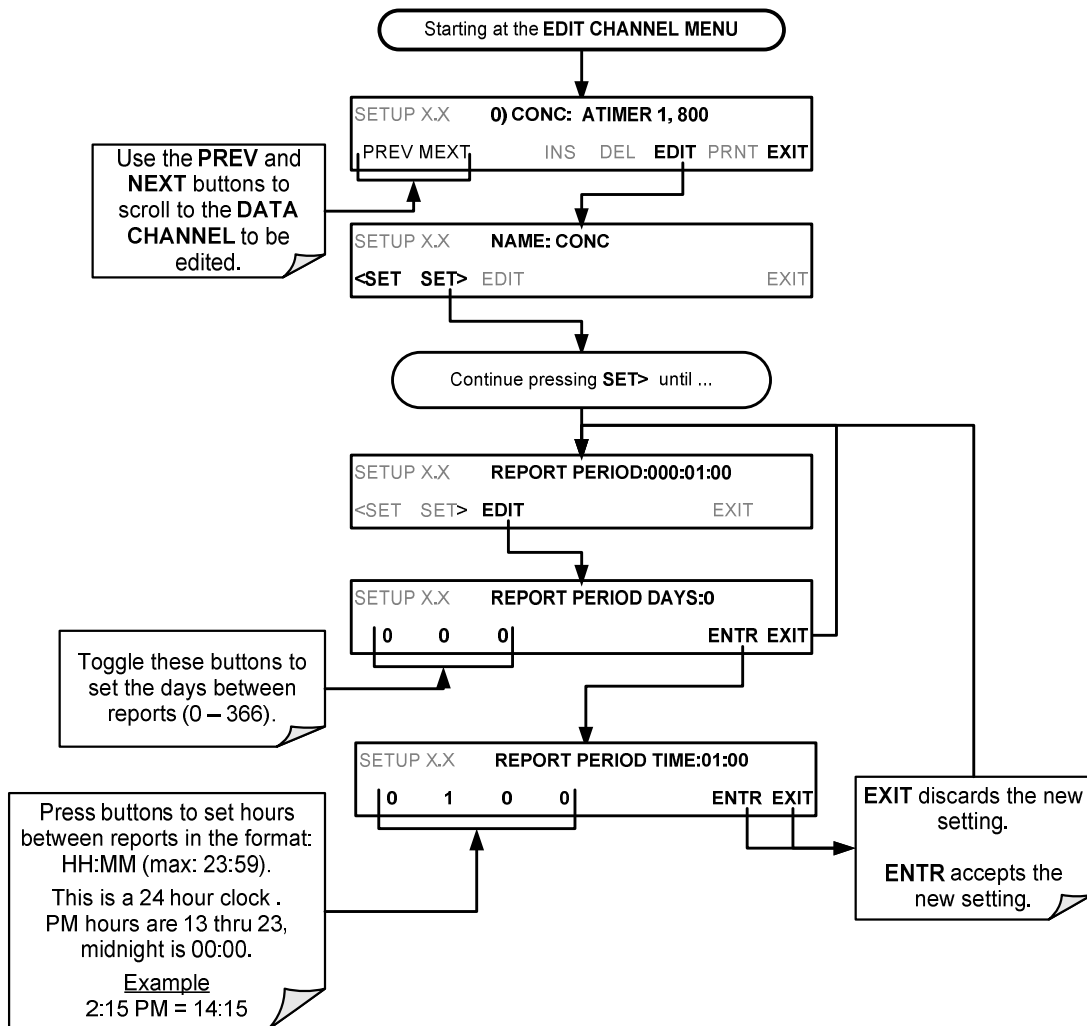

The **SAMPLE PERIOD** and **REPORT PERIOD** intervals are synchronized to the beginning and end of the appropriate interval of the instrument's internal clock.

- If **SAMPLE PERIOD** were set for one minute the first reading would occur at the beginning of the next full minute according to the instrument's internal clock.
- If the **REPORT PERIOD** were set for one hour, the first report activity would occur at the beginning of the next full hour according to the instrument's internal clock.

EXAMPLE:

Given the above settings, if the DAS were activated at 7:57:35 the first sample would occur at 7:58 and the first report would be calculated at 8:00 consisting of data points for 7:58, 7:59 and 8:00.

During the next hour (from 8:01 to 9:00), the instrument will take a sample reading every minute and include 60 sample readings.

Note

In **AVG, SDEV, MIN or MAX** sample modes (see Section 6.1.5.3), the settings for the **Sample Period** and the **Report Period** determine the number of data points used each time the parameter is calculated, stored and reported to the **COMM** ports.

The actual sample readings are not stored past the end of the chosen report period.

When the **STORE NUM SAMPLES** feature is turned on, the instrument will store the number of measurements used to compute the **AVG, SDEV, MIN or MAX Value**, but not the actual measurements themselves.

REPORT PERIODS IN PROGRESS WHEN INSTRUMENT IS POWERED OFF

If the instrument is powered off in the middle of a **REPORT PERIOD**, the samples accumulated so far during that period are lost. Once the instrument is turned back on, the DAS restarts taking samples and temporarily stores them in volatile memory as part of the **REPORT PERIOD** currently active at the time of restart. At the end of this **REPORT PERIOD PERIOD**, only the sample readings taken since the instrument was turned back on will be included in any **AVG, SDEV, MIN or MAX** calculation.

Also, the **STORE NUM SAMPLES** feature will report the number of sample readings taken since the instrument was restarted.

7.1.8. NUMBER OF RECORDS

The number of data records in the DAS is limited to about a cumulative one million data points in all channels (one megabyte of space on the Disk-on-Module). However, the actual number of records is also limited by the total number of parameters and channels and other settings in the DAS configuration. Every additional data channel, parameter, number of samples setting, etc., will reduce the maximum amount of data points. In general, however, the maximum data capacity is divided amongst all channels (max: 20) and parameters (max: 50 per channel).

The DAS will check the amount of available data space and prevent the user from specifying too many records at any given point. If, for example, the DAS memory space can accommodate 375 more data records, the **ENTR** button will disappear when trying to specify more than that number of records. This check for memory space may also cause the upload of a DAS configuration with APICOM or a terminal program to fail, if the combined number of records would be exceeded. In this case, it is suggested to either try to determine what the maximum number of records available is using the front panel interface or use trial-and-error in designing the DAS script or calculate the number of records using the DAS or APICOM manuals.

To set the **NUMBER OF RECORDS**, follow the instruction shown in Section 0 then press:

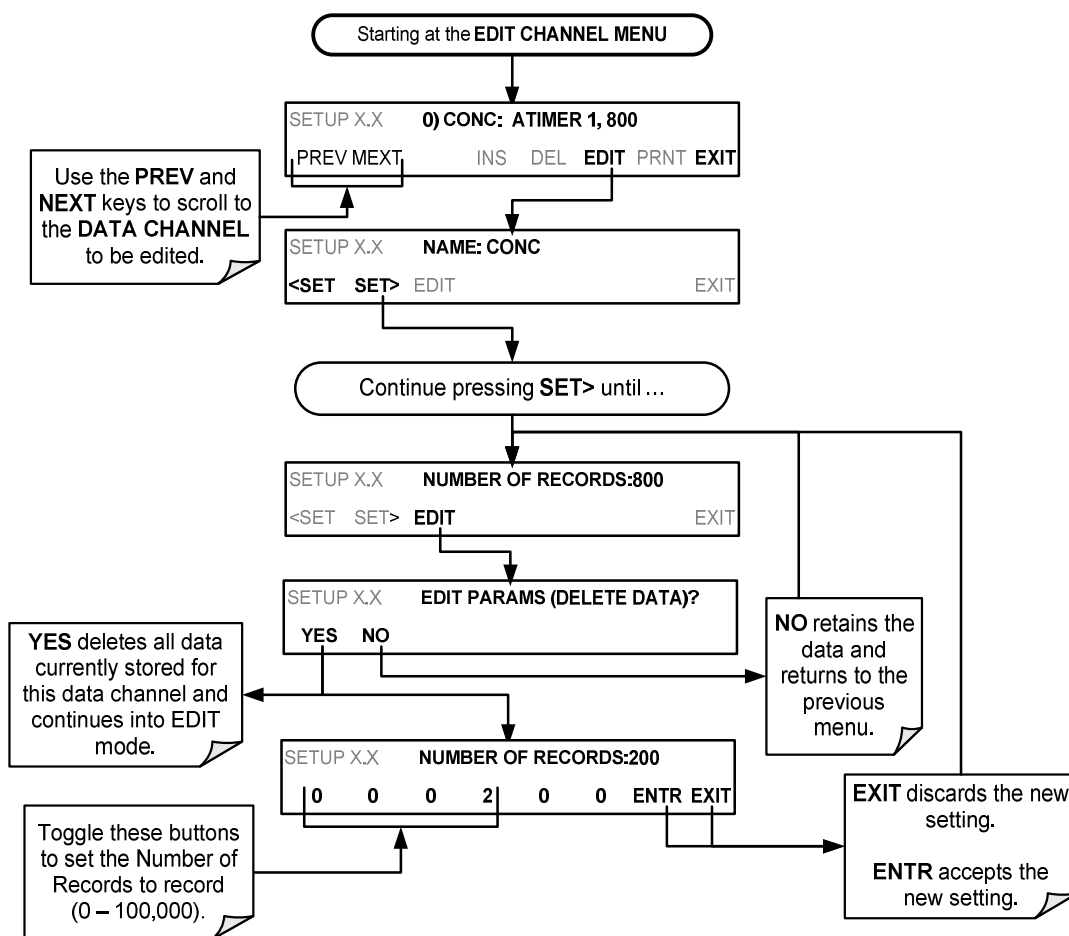

7.1.9. RS-232 REPORT FUNCTION

The DAS can automatically report data to the communications ports, where they can be captured with a terminal emulation program or simply viewed by the user using the APICOM software.

To enable automatic COMM port reporting, follow the instruction shown in Section 7.1.4 then press:

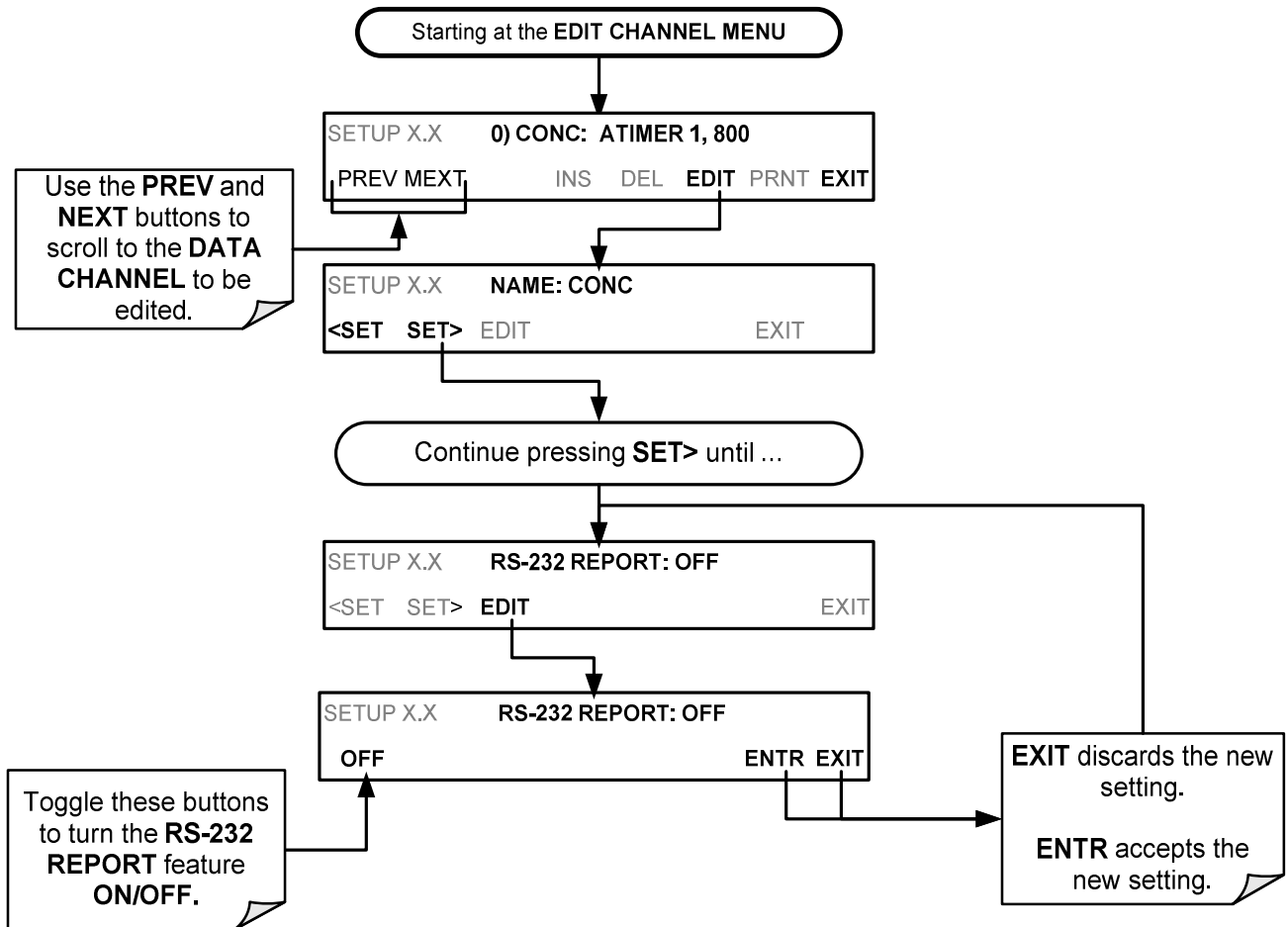

7.1.9.1. THE COMPACT REPORT FEATURE

When enabled, this option avoids unnecessary line breaks on all RS-232 reports. Instead of reporting each parameter in one channel on a separate line, up to five parameters are reported in one line.

The **COMPACT DATA REPORT** generally cannot be accessed from the standard DAS front panel menu, but is available via the instrument’s communication ports by using APICOM or the analyzer’s standard serial data protocol.

7.1.9.2. THE STARTING DATE FEATURE

This option allows the user to specify a starting date for any given channel in case the user wants to start data acquisition only after a certain time and date. If the **STARTING DATE** is in the past (the default condition), the DAS ignores this setting and begins recording data as defined by the **REPORT PERIOD** setting.

The **STARTING DATE** generally cannot be accessed from the standard DAS front panel menu, but is available via the instrument's communication ports by using APICOM or the analyzer's standard serial data protocol.

7.1.10. DISABLING/ENABLING DATA CHANNELS

Data channels can be temporarily disabled, which can reduce the read/write wear on the Disk-on-Module.

To disable a data channel, follow the instruction shown in Section 0 then press:

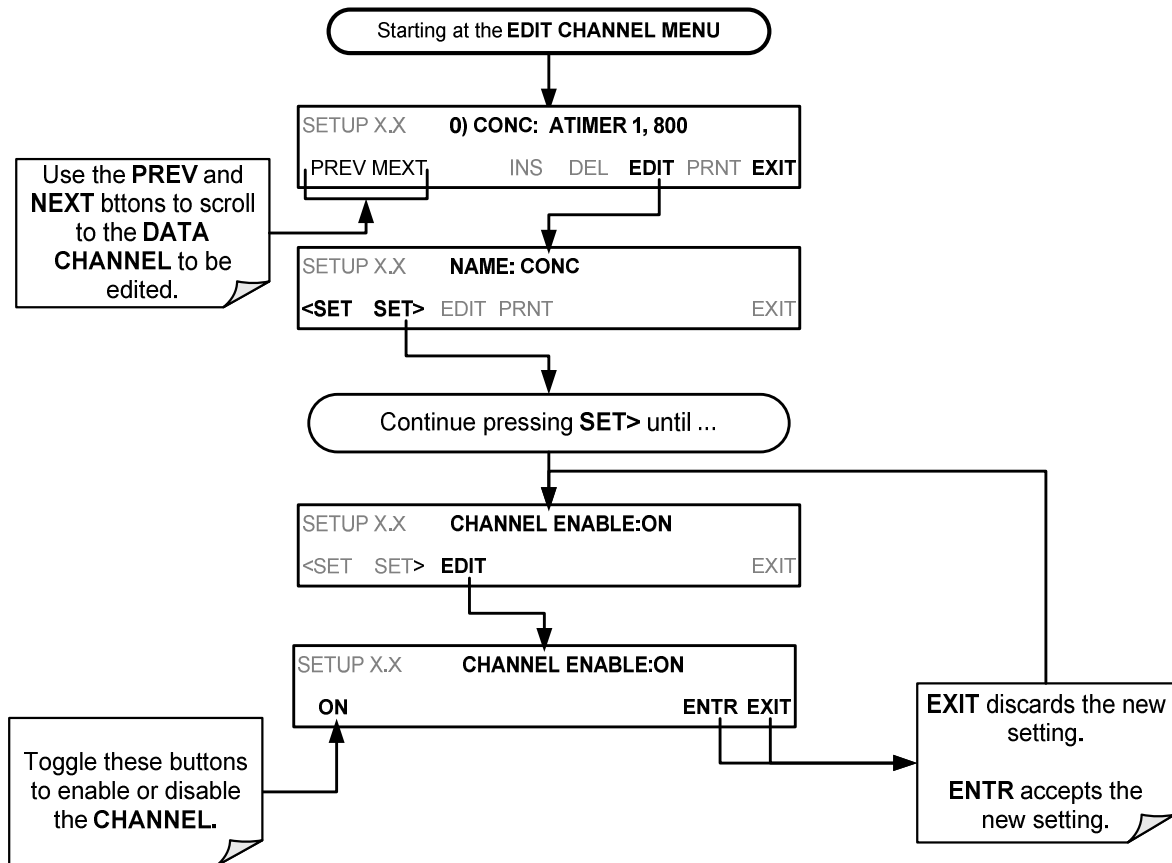

7.1.11. HOLDOFF FEATURE

The DAS **HOLDOFF** feature prevents data collection during calibration operations and at certain times when the quality of the analyzer’s N₂O measurements may not be certain (e.g. while the instrument is warming up). In this case, the length of time that the **HOLDOFF** feature is active is determined by the value of the internal variable (**VAR**S), DAS_HOLDOFF.

To set the length of the DAS_HOLDOFF period, go to the SETUP>MORE>VAR

S menu (Section 5.7) and EDIT the “(0) DAS_HOLD_OFF...” parameter.

To enable or disable the **HOLDOFF** feature for an individual channel, follow the instruction shown in Section 7.1.4 then press:

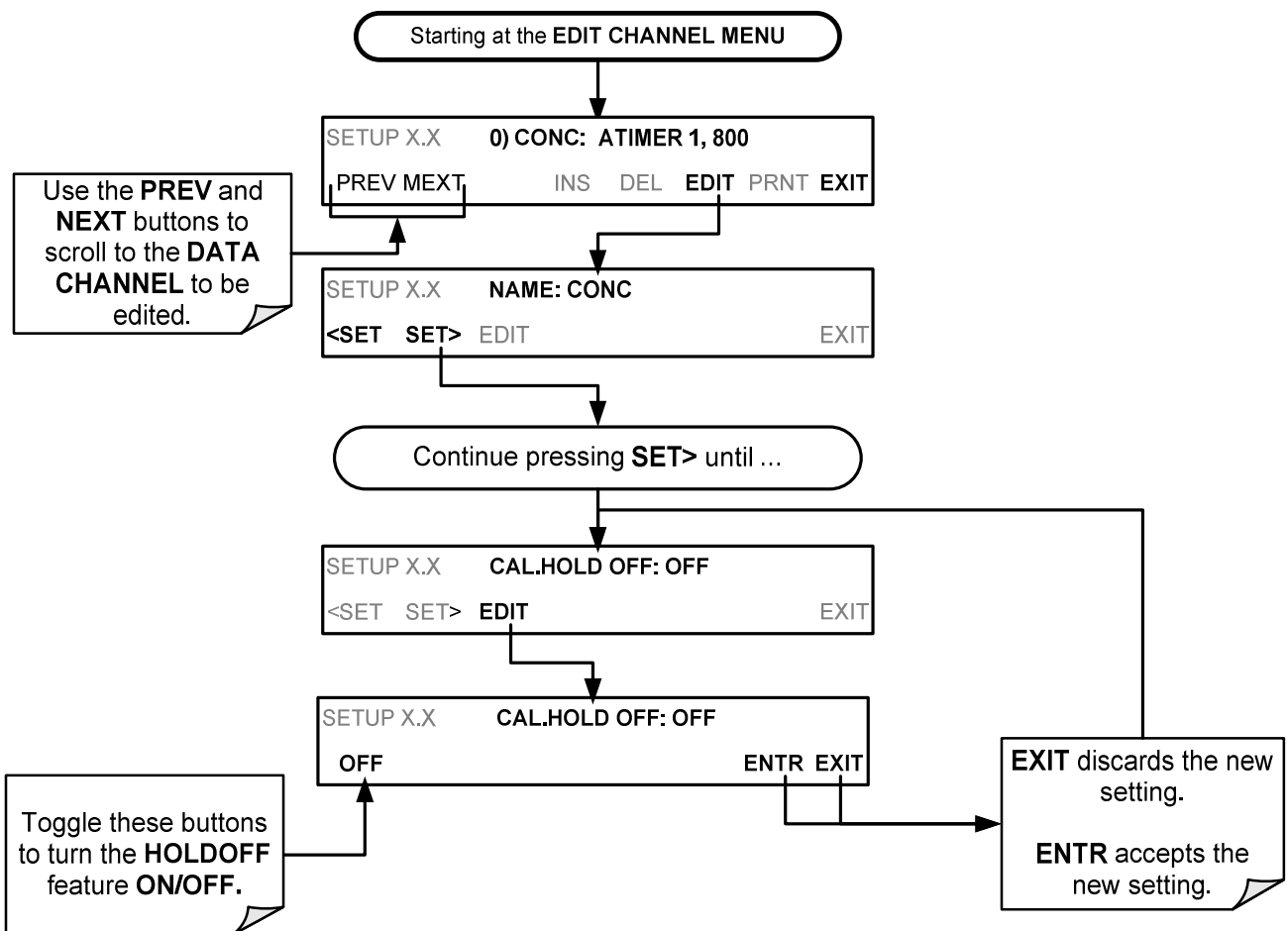

7.2. REMOTE DAS CONFIGURATION

The DAS can be configured and operated remotely via either the APICOM interface or a terminal emulation program. Once a DAS configuration is edited (which can be done offline and without interrupting DAS data collection), it is conveniently uploaded to the instrument and can be stored on a computer for later review, alteration or documentation and archival.

7.2.1. DAS CONFIGURATION VIA APICOM

Figure 7-2 shows examples of APICOM's main interface, which emulates the look and functionality of the instrument's actual front panel. Figure 7-3 shows an example of APICOM being used to remotely configure the DAS feature.

The APICOM user manual (Teledyne P/N 039450000) is included in the APICOM installation file, which can be downloaded at <http://www.teledyne-api.com/software/apicom/>.

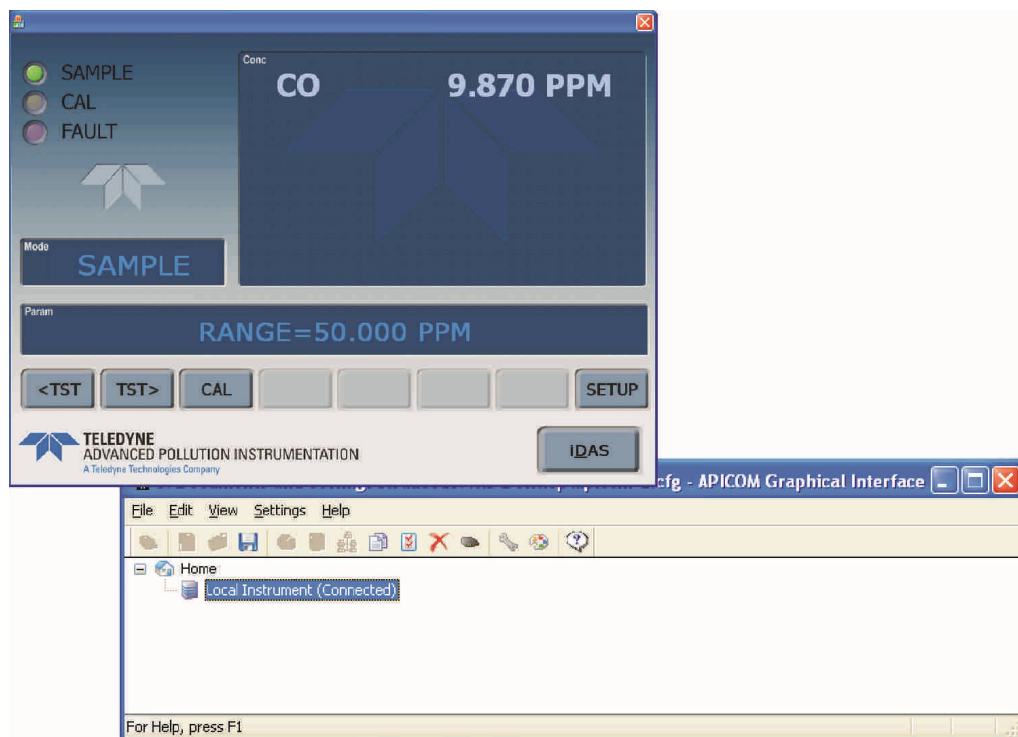

Figure 7-2: APICOM Remote Control Program Interface

Note: The above screen(s) show CO concentration displayed. Your instrument will indicate and display N₂O concentration.

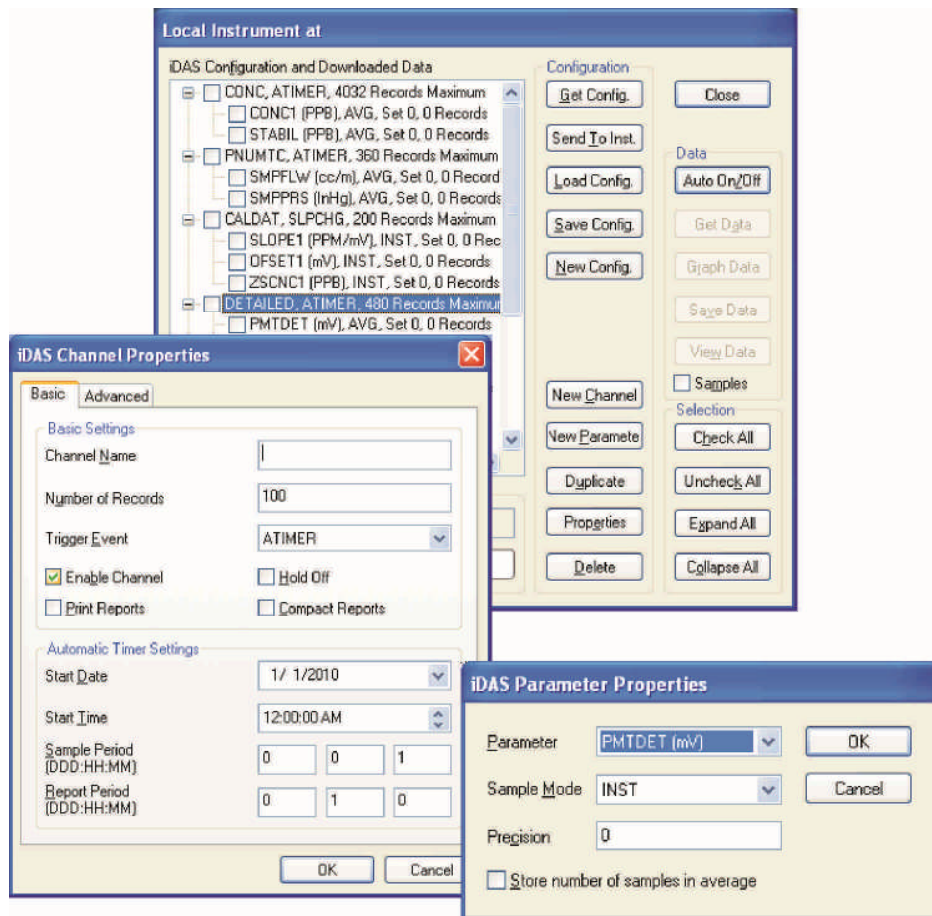

Figure 7-3: APICOM User Interface for Configuring the DAS

Once a DAS configuration is edited (which can be done offline and without interrupting DAS data collection), it is conveniently uploaded to the instrument and can be stored on a computer for later review, alteration or documentation and archival. Refer to the APICOM manual for details on these procedures. The APICOM user manual (Teledyne P/N 039450000) is included in the APICOM installation file, which can be downloaded at <http://www.teledyne-api.com/manuals/>.

7.2.2. DAS CONFIGURATION USING TERMINAL EMULATION PROGRAMS

Although TAI recommends the use of APICOM, the DAS can also be accessed and configured through a terminal emulation program such as HyperTerminal (see example in Figure 7-4).

To do this:

- All configuration commands must be created and edited off line (e.g. cut & pasted in from a text file or word processor) following a strict syntax (see below for example).
- The script is then uploaded via the instrument's RS-232 port(s).

```

SETUP PROPERTIES FOR ENGDAT:
NAME: ENGDAT
EVENT: ATIMER
REPORT PERIOD: 000:00:02
NUMBER OF RECORDS: 2000
RS-232 REPORT: ON
CHANNEL ENABLED: ON
CAL. HOLD OFF: OFF
PARAMETERS: 14
PARAMETER=RCTEMP, MODE=AVG, PRECISION=4, STORE_SAMPLES=OFF
PARAMETER=CNVTMP, MODE=AVG, PRECISION=4, STORE_SAMPLES=OFF
PARAMETER=PMTMP, MODE=AVG, PRECISION=4, STORE_SAMPLES=OFF
PARAMETER=BOXTMP, MODE=AVG, PRECISION=4, STORE_SAMPLES=OFF
PARAMETER=O3FLOW, MODE=AVG, PRECISION=4, STORE_SAMPLES=OFF
PARAMETER=SMPFLW, MODE=AVG, PRECISION=4, STORE_SAMPLES=OFF
PARAMETER=SMPPRS, MODE=AVG, PRECISION=4, STORE_SAMPLES=OFF
PARAMETER=RCPRES, MODE=AVG, PRECISION=4, STORE_SAMPLES=OFF
PARAMETER=AZERO, MODE=AVG, PRECISION=4, STORE_SAMPLES=OFF
PARAMETER=HVPS, MODE=AVG, PRECISION=4, STORE_SAMPLES=OFF
PARAMETER=PMTDET, MODE=AVG, PRECISION=4, STORE_SAMPLES=OFF
PARAMETER=RF4096, MODE=AVG, PRECISION=4, STORE_SAMPLES=OFF
PARAMETER=REFGND, MODE=AVG, PRECISION=4, STORE_SAMPLES=OFF
  
```

Figure 7-4: DAS Configuration Through a Terminal Emulation Program

Both of the above steps are best started by:

1. Downloading the default DAS configuration.
2. Getting familiar with its command structure and syntax conventions.
3. Altering a copy of the original file offline.
4. Uploading the new configuration into the analyzer.

IMPORTANT

IMPACT ON READINGS OR DATA

Whereas the editing, adding and deleting of DAS channels and parameters of one channel through the front-panel control buttons can be done without affecting the other channels, uploading a DAS configuration script to the analyzer through its communication ports will erase all data, parameters and channels by replacing them with the new DAS configuration. Backup of data and the original DAS configuration is advised before attempting any DAS changes.

Refer to Section 8.2.1 for details on remote access to and from the GFC7002T/GFC7002TU Analyzer via the instrument's COMM ports.

8. REMOTE OPERATION

This section provides information needed when using external digital and serial I/O for remote operation. It assumes that the electrical connections have been made as described in Section 3.3.1.

The GFC7002T can be remotely configured, calibrated or queried for stored data through the rear panel serial ports, via either **Computer mode** (using a personal computer) or **Interactive mode** (using a terminal emulation program).

8.1. COMPUTER MODE

Computer mode is used when the analyzer is connected to a computer with a dedicated interface program such as APICOM.

8.1.1. REMOTE CONTROL VIA APICOM

APICOM is an easy-to-use, yet powerful interface program that allows a user to access and control any of Teledyne's main line of ambient and stack-gas instruments from a remote connection through direct cable, modem or Ethernet. Running APICOM, a user can:

- Establish a link from a remote location to the GFC7002T through direct cable connection via RS-232 modem or Ethernet.
- View the instrument's front panel and remotely access all functions that could be accessed manually on the instrument.
- Remotely edit system parameters and set points.
- Download, view, graph and save data for predictive diagnostics or data analysis.
- Retrieve, view, edit, save and upload DAS configurations (Section 7.2.1).
- Check on system parameters for trouble-shooting and quality control.

APICOM is very helpful for initial setup, data analysis, maintenance and trouble-shooting. Refer to the APICOM manual available for download from <http://www.teledyne-api.com/software/apicom/>.

8.2. INTERACTIVE MODE

Interactive mode is used with a terminal emulation programs or a "dumb" computer terminal.

8.2.1. REMOTE CONTROL VIA A TERMINAL EMULATION PROGRAM

Start a terminal emulation program such as HyperTerminal. All configuration commands must be created following a strict syntax or be pasted in from an existing text file, which was edited offline and then uploaded through a specific transfer procedure. The commands that are used to operate the analyzer in this mode are listed in Table 8-1 and in Appendix A.

8.2.1.1. HELP COMMANDS IN INTERACTIVE MODE

Table 8-1: Interactive Mode Software Commands

COMMAND	Function
Control-T	Switches the analyzer to terminal mode (echo, edit). If mode flags 1 & 2 are OFF, the interface can be used in interactive mode with a terminal emulation program.
Control-C	Switches the analyzer to computer mode (no echo, no edit).
CR(carriage return)	A carriage return is required after each command line is typed into the terminal/computer. The command will not be sent to the analyzer to be executed until this is done. On personal computers, this is achieved by pressing the ENTER button.
BS (backspace)	Erases one character to the left of the cursor location.
ESC(escape)	Erases the entire command line.
?[ID] CR	This command prints a complete list of available commands along with the definitions of their functionality to the display device of the terminal or computer being used. The ID number of the analyzer is only necessary if multiple analyzers are on the same communications line, such as the multi-drop setup.

8.2.1.2. COMMAND SYNTAX

Commands are not case-sensitive and all arguments within one command (i.e. ID numbers, key words, data values, etc.) must be separated with a space character.

All Commands follow the syntax:

X [ID] COMMAND <CR>

Where:

X is the command type (one letter) that defines the type of command. Allowed designators are listed in Appendix A-6.

[ID] is the machine identification number (Section 5.6.2). Example: the Command “? 700” followed by a carriage return would print the list of available commands for the revision of software currently installed in the instrument assigned ID Number 700.

COMMAND is the command designator: This string is the name of the command being issued (LIST, ABORT, NAME, EXIT, etc.). Some commands may have additional arguments that define how the command is to be executed. Press ? <CR> or refer to Appendix A-6 for a list of available command designators.

<CR> is a carriage return. All commands must be terminated by a carriage return (usually achieved by pressing the ENTER button on a computer).

Table 8-2: Teledyne's Serial I/O Command Types

COMMAND	COMMAND TYPE
C	Calibration
D	Diagnostic
L	Logon
T	Test measurement
V	Variable
W	Warning

8.2.1.3. DATA TYPES

Data types consist of integers, hexadecimal integers, floating-point numbers, Boolean expressions and text strings.

Integer data: Used to indicate integral quantities such as a number of records, a filter length, etc.

- They consist of an optional plus or minus sign, followed by one or more digits.
- For example, +1, -12, 123 are all valid integers.

Hexadecimal integer data: Used for the same purposes as integers.

- They consist of the two characters "0x," followed by one or more hexadecimal digits (0-9, A-F, a-f), which is the 'C' programming language convention.
- No plus or minus sign is permitted.
- For example, 0x1, 0x12, 0x1234abcd are all valid hexadecimal integers.

Floating-point number: Used to specify continuously variable values such as temperature set points, time intervals, warning limits, voltages, etc.

- They consist of an optional plus or minus sign, followed by zero or more digits, an optional decimal point and zero or more digits.
- At least one digit must appear before or after the decimal point.
- Scientific notation is not permitted.
- For example, +1.0, 1234.5678, -0.1, 1 are all valid floating-point numbers.

Boolean expressions: Used to specify the value of variables or I/O signals that may assume only two values.

- They are denoted by the key words **ON** and **OFF**.

Text strings: Used to represent data that cannot be easily represented by other data types, such as data channel names, which may contain letters and numbers.

- They consist of a quotation mark, followed by one or more printable characters, including spaces, letters, numbers, and symbols, and a final quotation mark.
- For example, "a", "1", "123abc", and "() [] < >" are all valid text strings.
- It is not possible to include a quotation mark character within a text string.

Some commands allow you to access variables, messages, and other items. When using these commands,

- you must type the entire name of the item
- you cannot abbreviate any names.

8.2.1.4. STATUS REPORTING

Reporting of status messages as an audit trail is one of the three principal uses for the RS-232 interface (the other two being the command line interface for controlling the instrument and the download of data in electronic format). You can effectively disable the reporting feature by setting the interface to quiet mode (see Section 6.2.1, Table 6-1). Status reports include warning messages, calibration and diagnostic status messages. Refer to Appendix A-3 for a list of the possible messages, and this for information on controlling the instrument through the RS-232 interface.

8.2.1.5. GENERAL MESSAGE FORMAT

All messages from the instrument (including those in response to a command line request) are in the format:

X DDD:HH:MM [Id] MESSAGE<CRLF>

Where:

X is a command type designator, a single character indicating the message type, as shown in the

Table 8-2.

DDD:HH:MM is the time stamp, the date and time when the message was issued. It consists of the Day-of-year (DDD) as a number from 1 to 366, the hour of the day (HH) as a number from 00 to 23, and the minute (MM) as a number from 00 to 59.

[ID] is the analyzer ID, a number with 1 to 4 digits.

MESSAGE is the message content that may contain warning messages, test measurements, variable values, etc.

<CRLF> is a carriage return / line feed pair, which terminates the message.

The uniform nature of the output messages makes it easy for a host computer to parse them into an easy structure. Keep in mind that the front panel display does not give any information on the time a message was issued, hence it is useful to log such messages for trouble-shooting and reference purposes. Terminal emulation programs such as HyperTerminal can capture these messages to text files for later review.

8.3. REMOTE ACCESS BY MODEM

The GFC7002T/GFC7002TU can be connected to a modem for remote access. This requires a cable between the analyzer's COMM port and the modem, typically a DB-9F to DB-25M cable (available from TAI with P/N WR0000024).

Once the cable has been connected, check to make sure:

- The DTE-DCE is in the DCE position.
- The GFC7002T/GFC7002TU COMM port is set for a baud rate that is compatible with the modem,
- The modem is designed to operate with an 8-bit word length with one stop bit.
- The MODEM ENABLE communication mode is turned on (Mode 64, see Table 6-1).

Once this is completed, the appropriate setup command line for your modem can be entered into the analyzer. The default setting for this feature is:

AT Y0 &D0 &H0 &I0 S0=2 &B0 &N6 &M0 E0 Q1 &W0

This string can be altered to match your modem's initialization and can be up to 100 characters long.

To change this setting press:

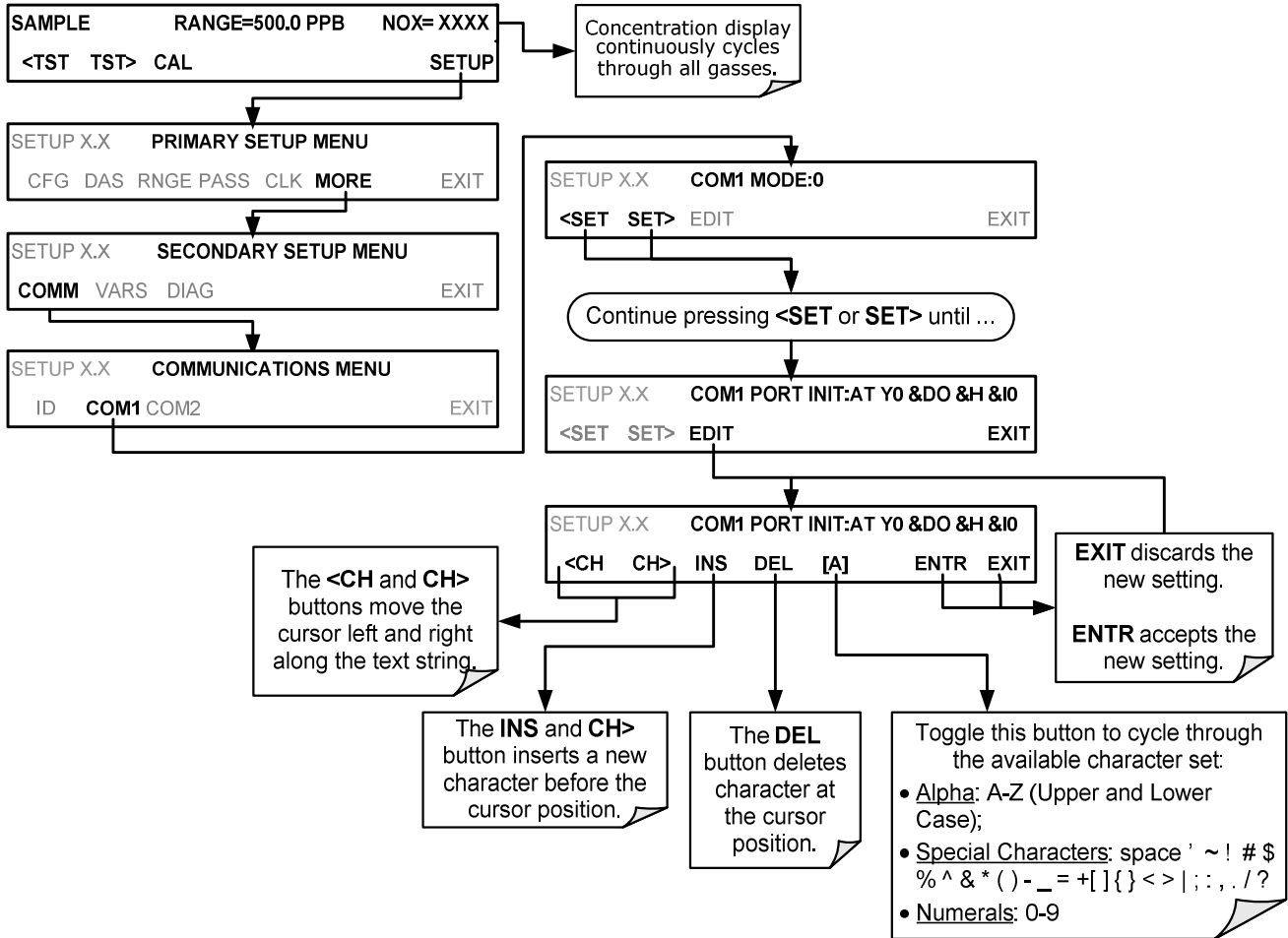

To initialize the modem press:

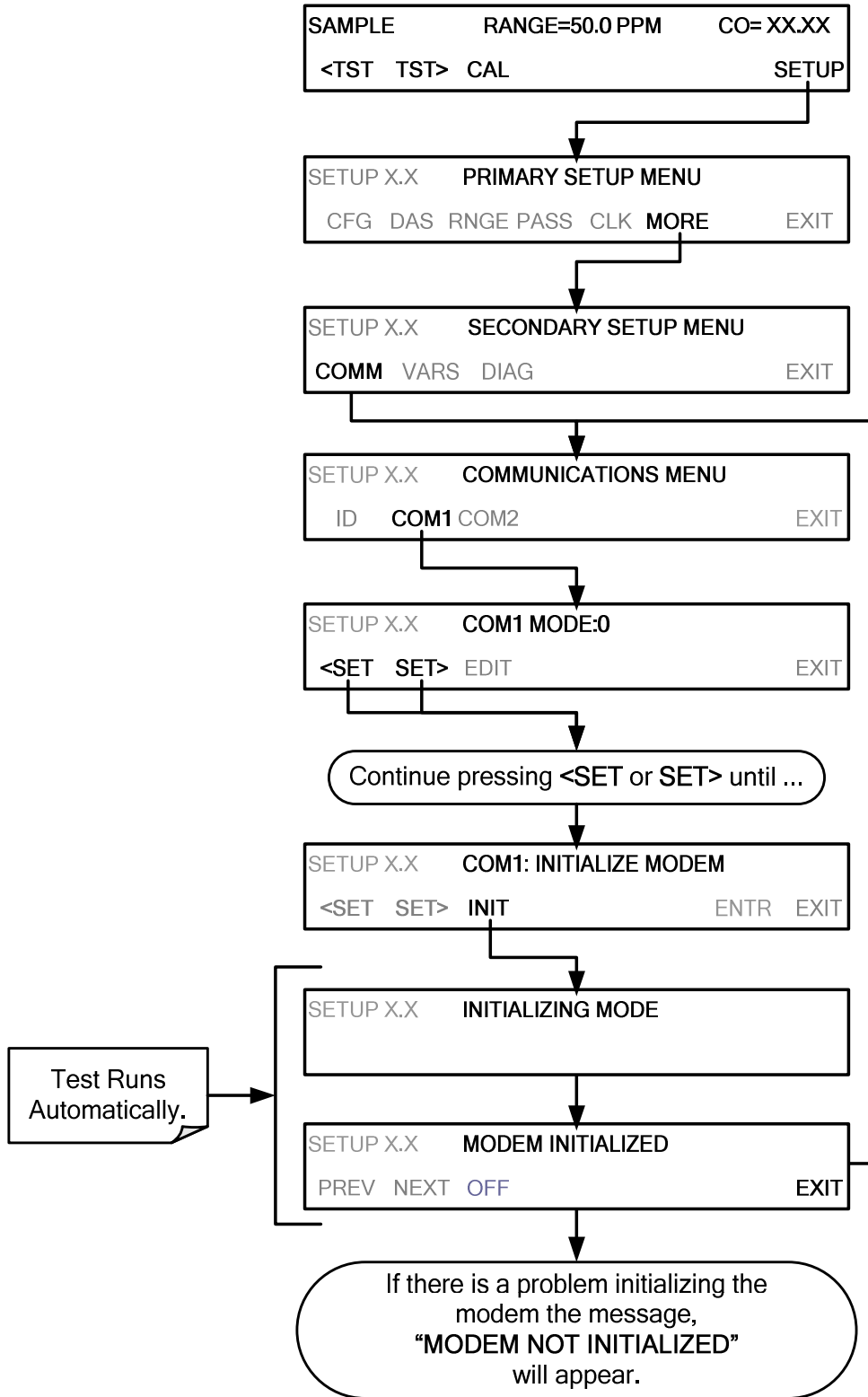

Note: The above screen(s) show CO concentration displayed. Your instrument will indicate and display N₂O concentration.

8.4. PASSWORD SECURITY FOR SERIAL REMOTE COMMUNICATIONS

In order to provide security for remote access of the GFC7002T/GFC7002TU, a **LOGON** feature can be enabled to require a password before the instrument will accept commands. This is done by turning on the **SECURITY MODE** (Mode 4, Table 6-1). Once the **SECURITY MODE** is enabled, the following items apply.

- A password is required before the port will respond or pass on commands.
- If the port is inactive for one hour, it will automatically logoff, which can also be achieved with the LOGOFF command.
- Three unsuccessful attempts to log on with an incorrect password will cause subsequent logins to be disabled for 1 hour, even if the correct password is used.
- If not logged on, the only active command is the '?' request for the help screen.
- The following messages will be returned at logon:
- LOGON SUCCESSFUL - Correct password given
- LOGON FAILED - Password not given or incorrect
- LOGOFF SUCCESSFUL - Connection terminated successfully

To log on to the GFC7002T/GFC7002TU Analyzer with **SECURITY MODE** feature enabled, type:

LOGON 940331

940331 is the default password. To change the default password, use the variable RS-232_PASS issued as follows:

```
V RS-232_PASS=NNNNNN
```

Where N is any numeral between 0 and 9.

This page intentionally left blank.

9. CALIBRATION PROCEDURES

This section describes the calibration procedures for the GFC7002T/GFC7002TU. All of the methods described in this section can be initiated and controlled through the COM ports.

IMPORTANT

IMPACT ON READINGS OR DATA

If you are using the GFC7002T/GFC7002TU for US-EPA controlled monitoring, refer to Section Error! Reference source not found. for information on the EPA calibration protocol.

Note

Throughout this section are various diagrams showing pneumatic connections between the GFC7002T/GFC7002TU and various other pieces of equipment such as calibrators and zero air sources.

These diagrams are only intended to be schematic representations of these connections and do not reflect actual physical locations of equipment and fitting location or orientation.

Contact your regional EPA or other appropriate governing agency for more detailed recommendations.

9.1. CALIBRATION PREPARATIONS

The calibration procedures in this section assume that the range mode, analog range and units of measure have already been selected for the analyzer. If this has not been done, please do so before continuing (see Section 0 for instructions).

- Delivering span and zero gases for the higher resolution the GFC 7002T/GFC 7002TU can be difficult. Attention must be paid to the quality of the gases, the level of contaminants in the gases as well as the history and conditioning of the gas delivery components.
- The analyzer must be continually operating with an adequate flow of sample gas, for 2 hours prior to performing a calibration (12 hours is recommended for the initial calibration).
 - DO NOT calibrate the analyzer if it has been turned off or if no sample gas has been flow through it within the last 2 hours.
- After this stabilization period is complete and just prior to performing the initial calibration, force the instrument to perform an auto-reference measurement.

9.1.1. REQUIRED EQUIPMENT, SUPPLIES, AND EXPENDABLES

Calibration of the GFC7002T/GFC7002TU Analyzer requires specific equipment and supplies. These include, but are not limited to, the following:

- Gas lines to and from the analyzer should be PTFE or FEP Teflon, glass, or stainless steel only.
- Zero-air source which must be synthetic air, ultra-zero air or nitrogen (N₂). A zero air generator like a T-API M701 should not be used.
- Span gas source (defined in Section 9.1.1.2 below).
- A recording device such as a strip-chart recorder and/or data logger (optional). Data recording device should be capable of bi-polar operation so that negative readings can be recorded.
- For electronic documentation, the internal data acquisition system can be used.

9.1.1.1. ZERO AIR

Zero air or zero calibration gas is defined as a gas that is similar in chemical composition to the measured medium but without the gas to be measured by the analyzer.

For the GFC7002T/GFC7002TU zero air should contain less than 25 ppb of N₂O and other major interfering gases such as water vapor. It should have a dew point of -5°C or less.

If your application is not a measurement in ambient air, the zero calibration gas should be matched to the composition of the gas being measured.

Pure nitrogen (N₂) can be used as a zero gas for applications where N₂O is measured in nitrogen.

9.1.1.2. SPAN GAS

Span Gas is a gas specifically mixed to match the chemical composition of the type of gas being measured at near full scale of the desired measurement range. It is recommended that the span gas used have a concentration equal to 80-90% of the full measurement range.

If Span Gas is sourced directly from a calibrated, pressurized tank, the gas mixture should be N₂O mixed with Zero Air or N₂ at the required ratio.

For oxygen measurements using the optional O₂ sensor, we recommend a reference gas of 21% O₂ in N₂.

- For quick checks, ambient air can be used at an assumed concentration of 20.8%.
- Generally, O₂ concentration in dry, ambient air varies by less than 1%.

9.1.1.3. CALIBRATION GAS STANDARDS AND TRACEABILITY

All equipment used to produce calibration gases should be verified against standards of the National Institute for Standards and Technology (NIST). To ensure NIST traceability, we recommend to acquire cylinders of working gas that are certified to be traceable to NIST Standard Reference Materials (SRM). These are available from a variety of commercial sources.

Note

 It is generally a good idea to use 80% of the reporting range for that channel for the span point calibration.

For instance, if the reporting range of the instrument is set for 50.0 PPM, the proper span gas would be 40.0 PPM.

9.1.2. DATA RECORDING DEVICES

A strip chart recorder, data acquisition system or digital data acquisition system should be used to record data from the serial or analog outputs of the GFC7002T/GFC7002TU.

- If analog readings are used, the response of the recording system should be checked against a NIST traceable voltage source or meter.
- Data recording devices should be capable of bi-polar operation so that negative readings can be recorded.
- For electronic data recording, the GFC7002T/GFC7002TU provides an internal data acquisition system (DAS), which is described in detail in Section 7.

APICOM, a remote control program, is also provided as a convenient and powerful tool for data handling, download, storage, quick check and plotting (see Section 7.2.1).

9.2. MANUAL CALIBRATION

IMPORTANT

IMPACT ON READINGS OR DATA
ZERO/SPAN CALIBRATION CHECKS VS. ZERO/SPAN CALIBRATION

Pressing the ENTR button during the following procedure resets the stored values for OFFSET and SLOPE and alters the instrument's Calibration.

This should **ONLY BE DONE** during an actual calibration of the GFC7002T/GFC7002TU.

NEVER press the ENTR button if you are only checking calibration. If you wish to perform a calibration CHECK, do not press ENTR and refer to Section 9.2.2.

9.2.1. SETUP FOR BASIC CALIBRATION CHECKS AND CALIBRATION

STEP ONE: Connect the Sources of Zero Air and Span Gas as shown below.

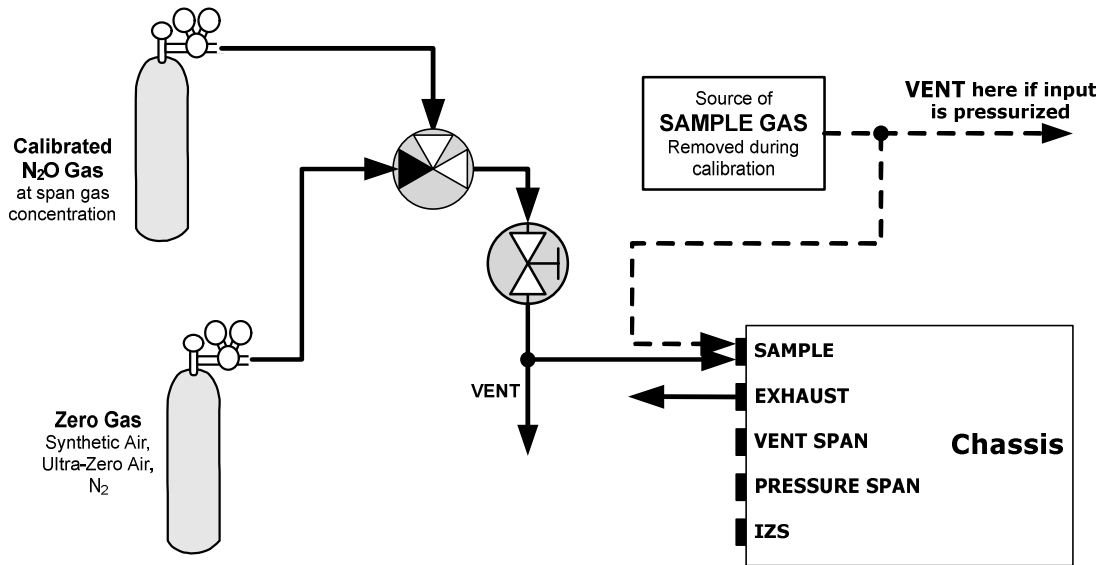

Figure 9-1: Pneumatic Connections – Basic Configuration – Using Bottled Span Gas

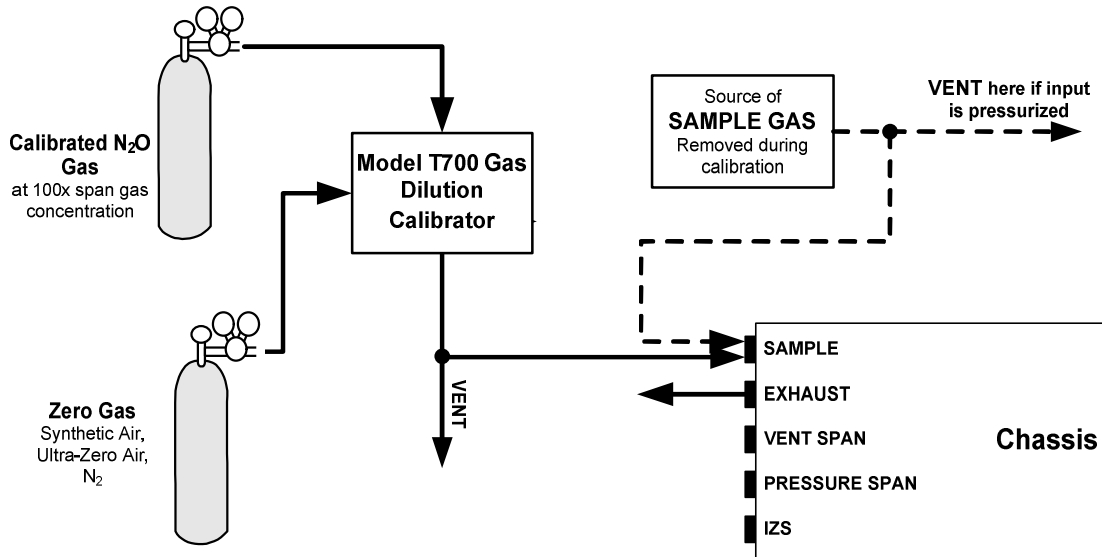
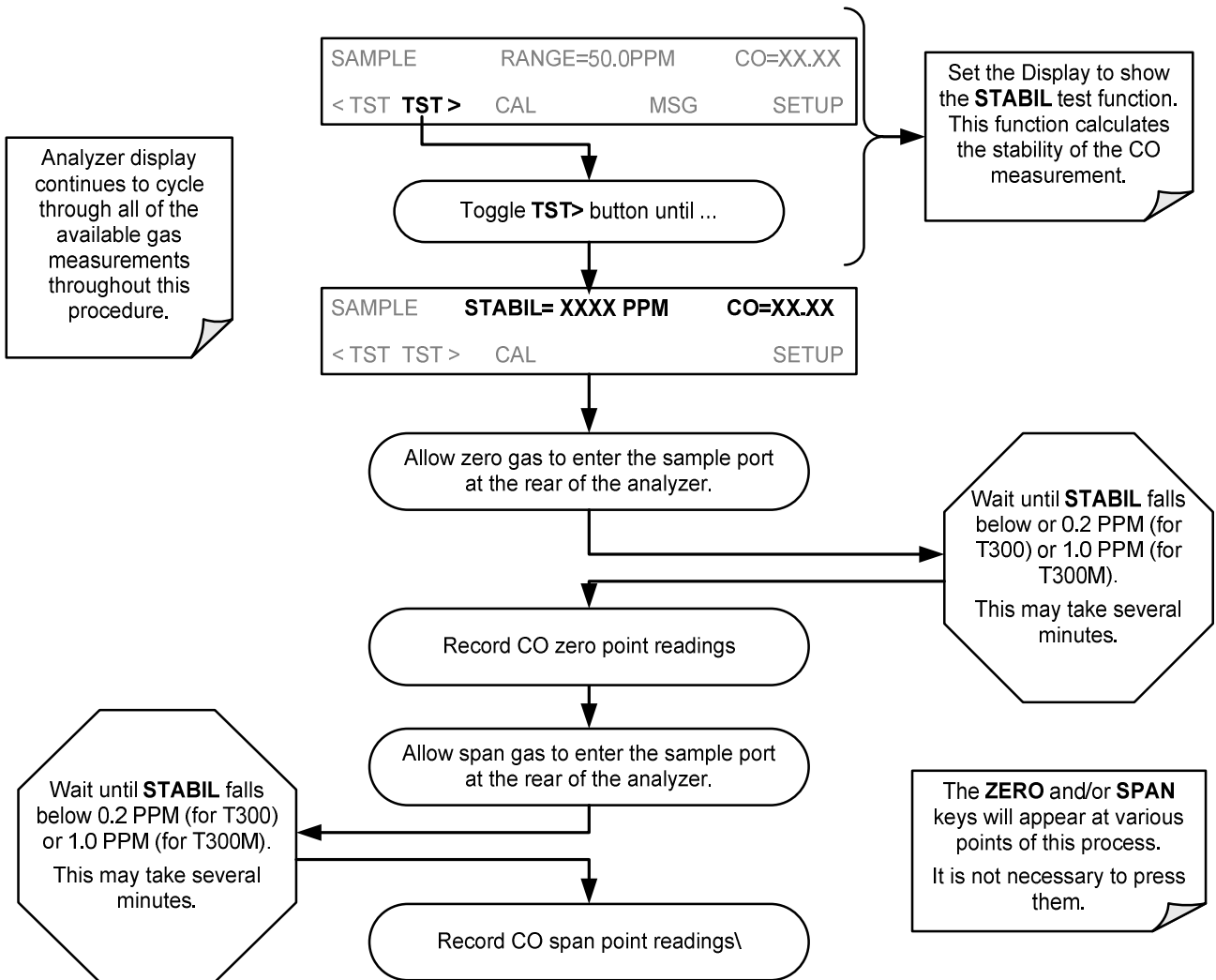

Figure 9-2: Pneumatic Connections – Basic Configuration – Using Gas Dilution Calibrator

9.2.2. PERFORMING A BASIC MANUAL CALIBRATION CHECK



Note: The above screen(s) show CO concentration displayed. Your instrument will indicate and display N₂O concentration.

Performing a Basic Manual Calibration

The following section describes the basic method for manually calibrating the GFC7002T/GFC7002TU.

If the analyzer's reporting range is set for the **AUTO** range mode, a step will appear for selecting which range is to be calibrated (**LOW** or **HIGH**). Each of these two ranges **MUST** be calibrated separately.

IMPORTANT**IMPACT ON READINGS OR DATA**

If the ZERO or SPAN buttons are not displayed during zero or span calibration, the measured concentration value during this time is out of the range allowed for a reliable calibration. Refer to Section 10 for troubleshooting tips.

9.2.2.1. SETTING THE EXPECTED SPAN GAS CONCENTRATION

Note

When setting expected concentration values, consider impurities in your span gas.

The expected N₂O span gas concentration should be 80% of the reporting range of the instrument (see Section 5.4.1).

The default factory setting is 40 ppm. To set the span gas concentration, press:

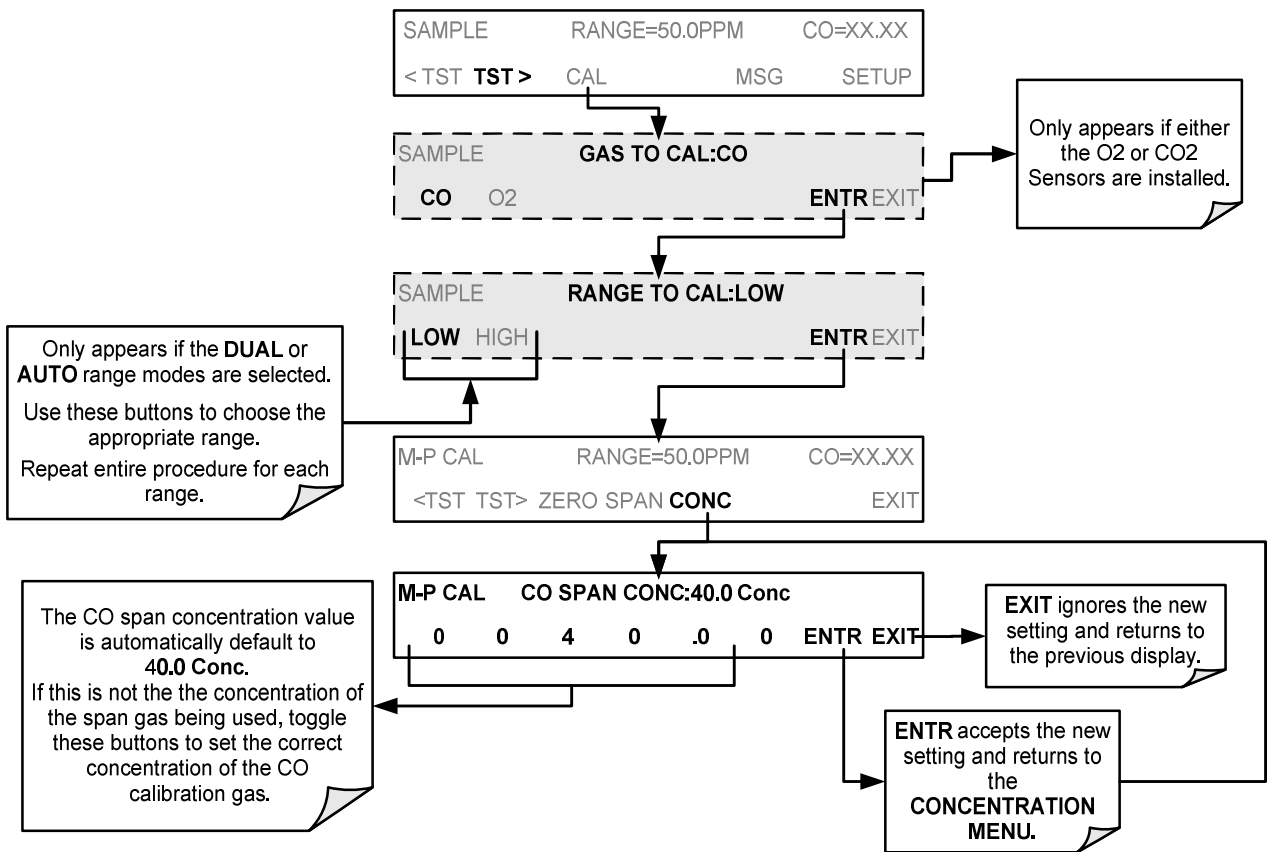

Note: The above screen(s) show CO concentration displayed. Your instrument will indicate and display N₂O concentration.

IMPORTANT

IMPACT ON READINGS OR DATA

For this Initial Calibration it is important to independently verify the PRECISE N₂O Concentration Value of the SPAN gas.

If the source of the Span Gas is from a Calibrated Bottle, use the exact concentration value printed on the bottle.

9.2.2.2. ZERO/SPAN POINT CALIBRATION PROCEDURE

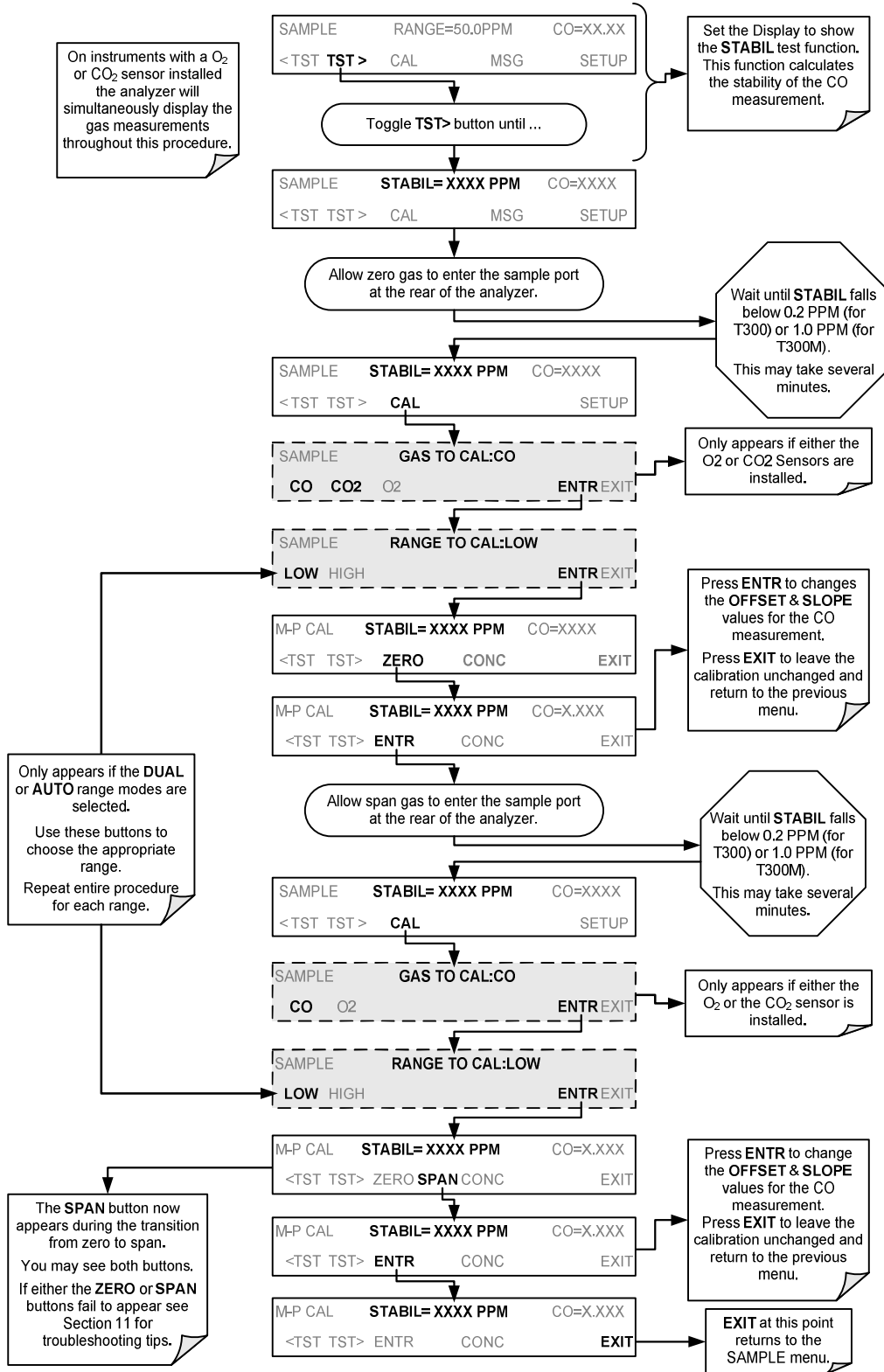

Note: The above screen(s) show CO concentration displayed. Your instrument will indicate and display N₂O concentration.

Manual Calibration with Zero/Span Valves

There are a variety of valve options available on the GFC7002T/GFC7002TU for handling calibration gases (see Table 1-1 for descriptions of each).

Generally performing calibration checks and zero/span point calibrations on analyzers with these options installed is similar to the methods discussed in the previous sections of this section. The primary differences are:

- On instruments with Z/S valve options, zero air and span gas is supplied to the analyzer through other gas inlets besides the sample gas inlet.
- The zero and span calibration operations are initiated directly and independently with dedicated buttons (**CALZ** & **CALS**).

9.2.3. SETUP FOR CALIBRATION USING VALVE OPTIONS

Each of the various calibration valve options requires a different pneumatic setup that is dependent on the exact nature and number of valves present.

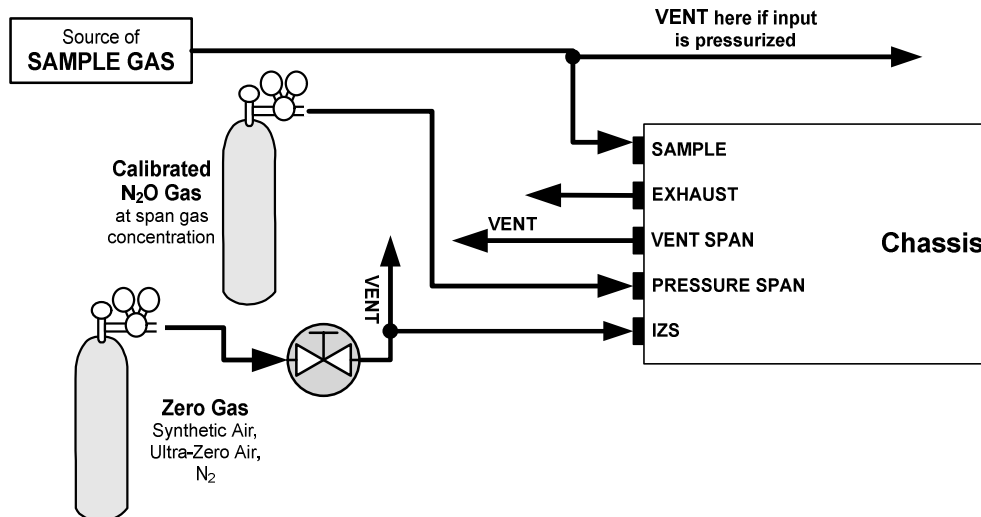

Figure 9-3: Pneumatic Connections – Option Z/S: Ambient Zero/Pressurized Span Calibration Valves

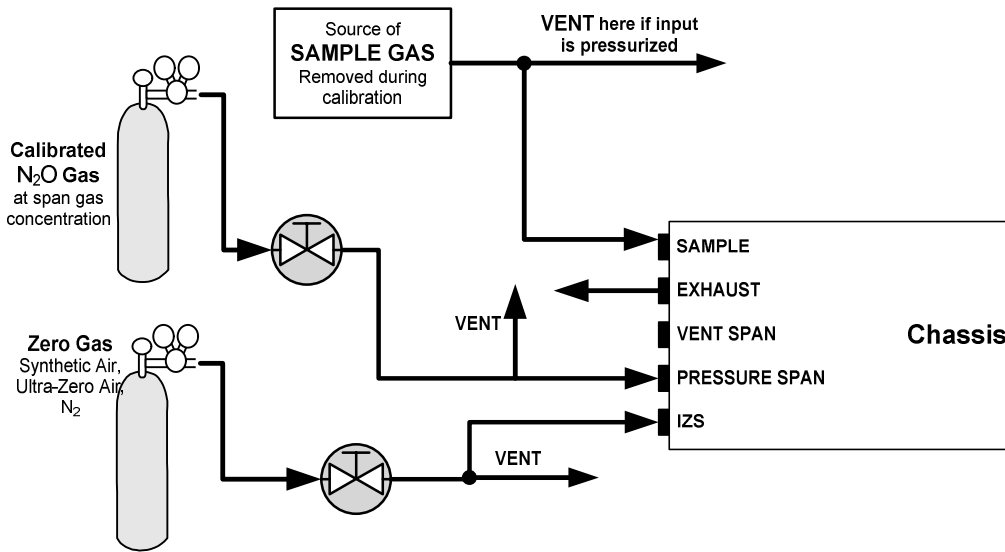

Figure 9-4: Pneumatic Connections – Option Z/S Without Shutoff Valve

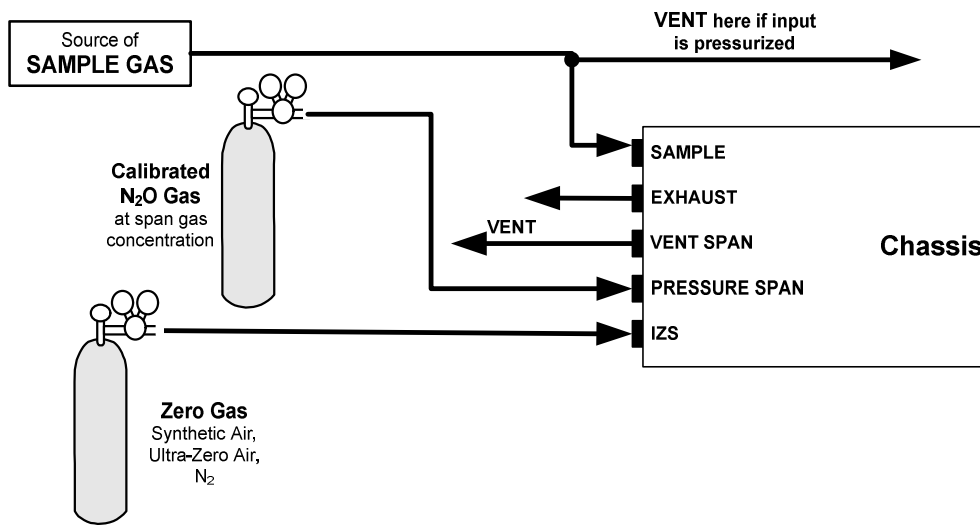
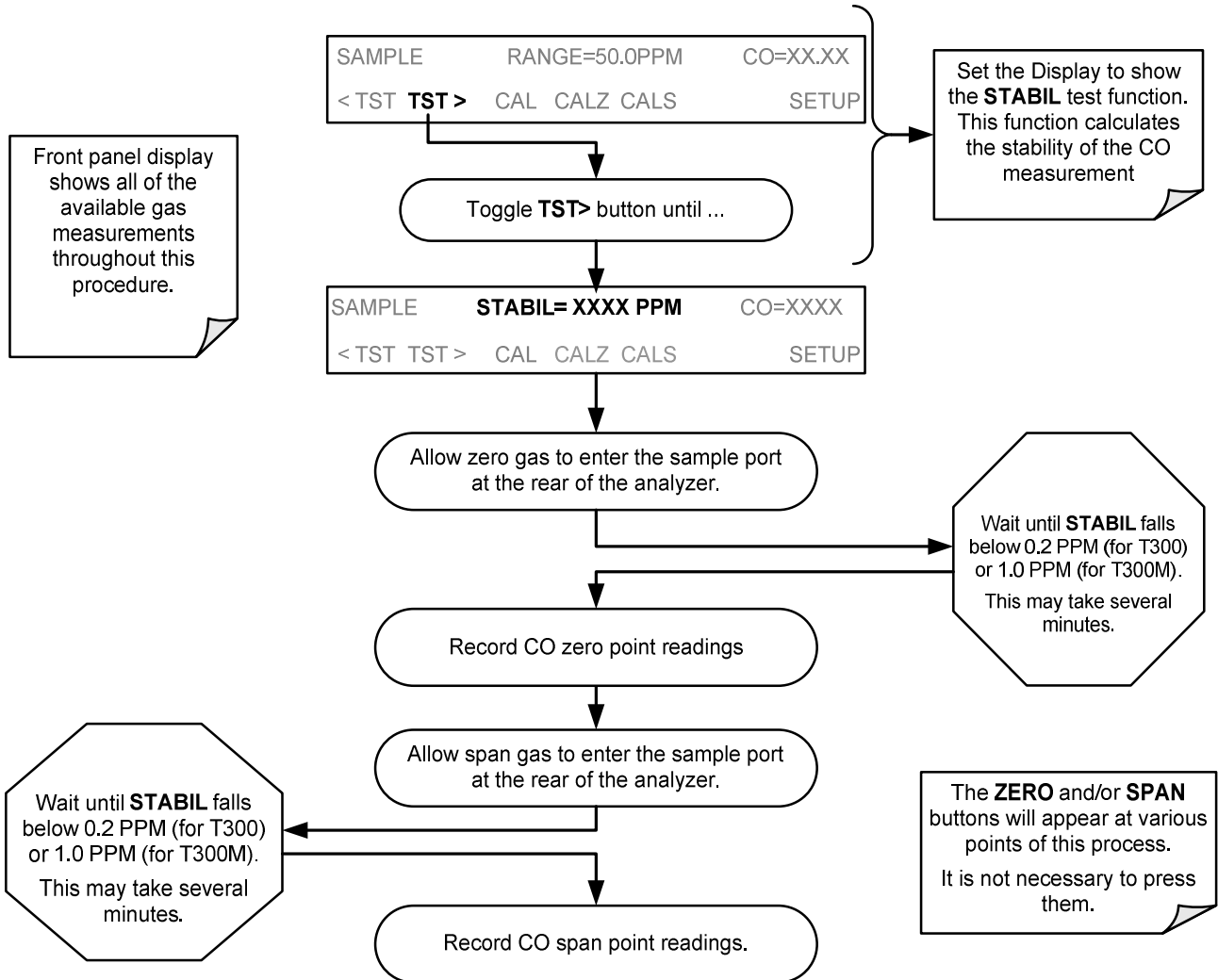

Figure 9-5: Pneumatic Connections – Option Z/S Valve with Common Shutoff Valve for Pressurized Zero and Span

9.2.4. MANUAL CALIBRATION CHECKS WITH VALVE OPTIONS INSTALLED



Note: The above screen(s) show CO concentration displayed. Your instrument will indicate and display N₂O concentration.

Manual Calibration Using Valve Options

The following section describes the basic method for manually calibrating the GFC7002T/GFC7002TU Analyzer.

If the analyzer's reporting range is set for the **DUAL** or **AUTO** range modes, a step will appear for selecting which range is to be calibrated (**LOW** or **HIGH**).

IMPORTANT

IMPACT ON READINGS OR DATA
Each of these two ranges MUST be calibrated separately.

9.2.4.1. SETTING THE EXPECTED SPAN GAS CONCENTRATION

Note

When setting expected concentration values, consider impurities in your span gas.

The expected N₂O span gas concentration should be 80% of the reporting range of the instrument (see Section 5.4.1). The default factory setting is 40 ppm.

To set the span gas concentration, press:

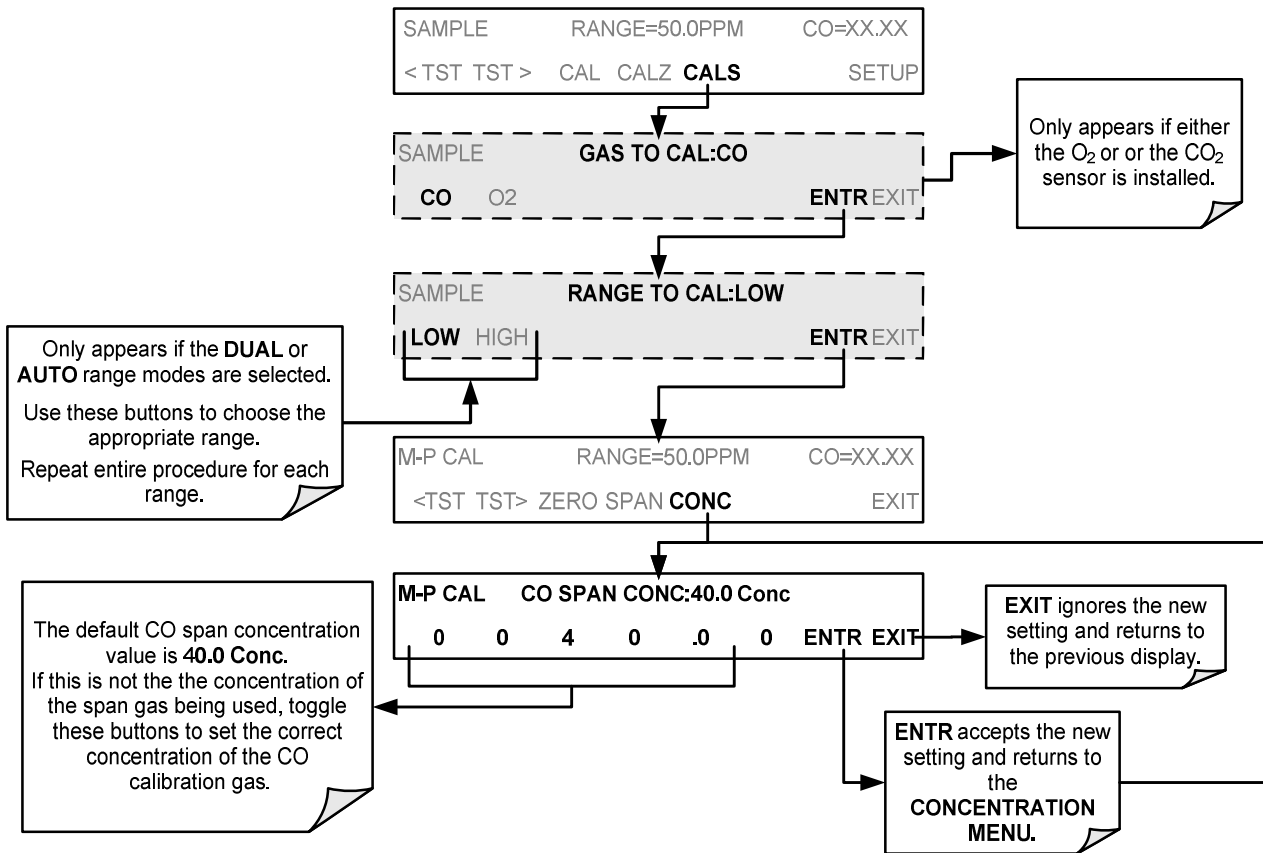

Note: The above screen(s) show CO concentration displayed. Your instrument will indicate and display N₂O concentration.

IMPORTANT**IMPACT ON READINGS OR DATA**

For this Initial Calibration it is important to independently verify the PRECISE N₂O Concentration Value of the SPAN gas.

If the source of the Span Gas is from a Calibrated Bottle, use the exact concentration value printed on the bottle.

9.2.4.2. ZERO/SPAN POINT CALIBRATION PROCEDURE

The zero and cal operations are initiated directly and independently with dedicated buttons (**CALZ** & **CALS**).

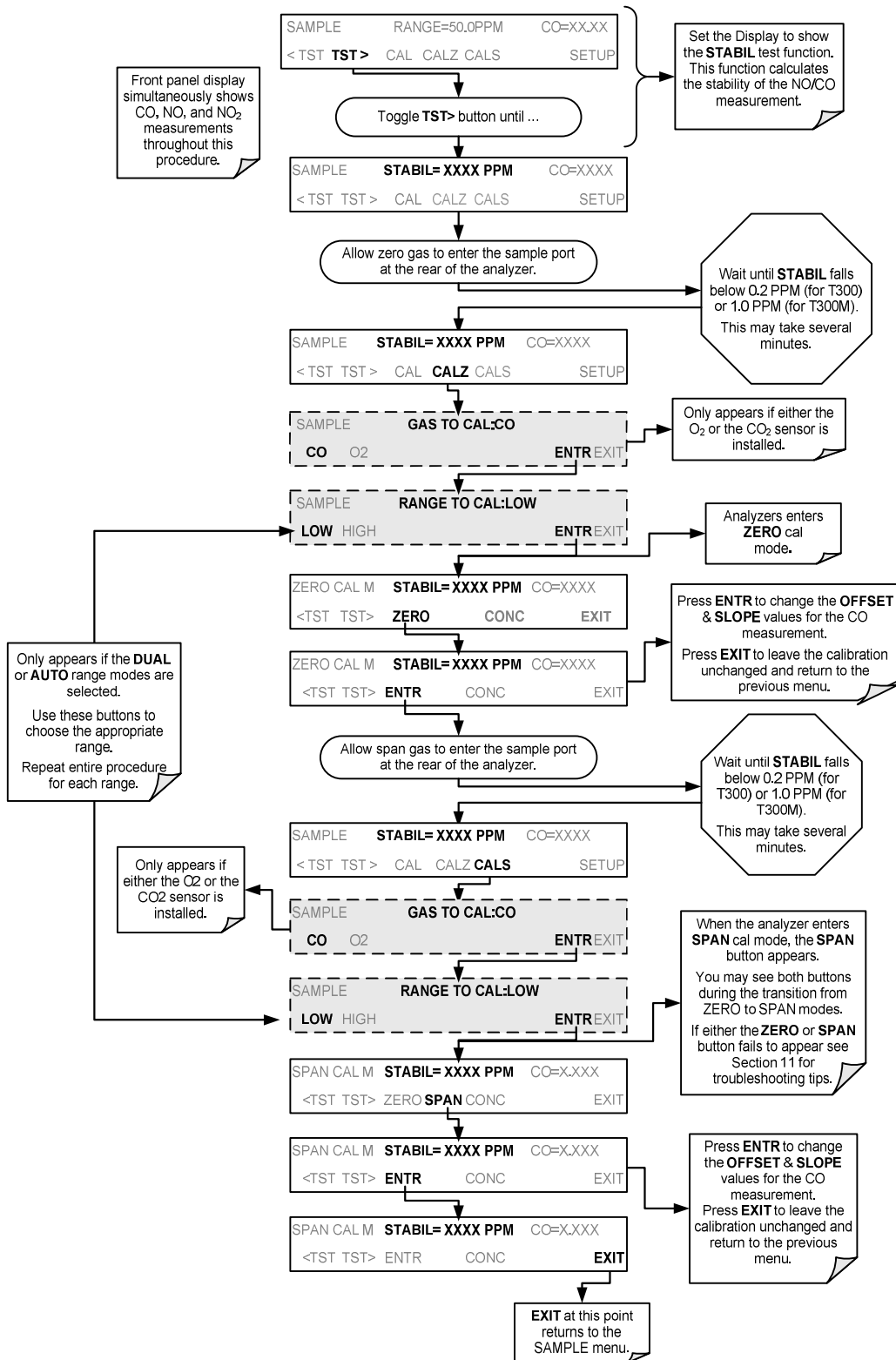

Note: The above screen(s) show CO concentration displayed. Your instrument will indicate and display N₂O concentration.

9.2.4.3. USE OF ZERO/SPAN VALVE WITH REMOTE CONTACT CLOSURE

Contact closures for controlling calibration and calibration checks are located on the rear panel **CONTROL IN** connector. Instructions for setup and use of these contacts can be found in Section 3.3.1.6.

When the appropriate contacts are closed for at least 5 seconds, the instrument switches into zero, or span calibration mode and any internal zero/span valves installed will be automatically switched to the appropriate configuration.

- The remote calibration contact closures may be activated in any order.
- It is recommended that contact closures remain closed for at least 10 minutes to establish a reliable reading.
- The instrument will stay in the selected mode for as long as the contacts remain closed.

If contact closures are being used in conjunction with the analyzer's AutoCal (see Section 9.3) feature and the AutoCal attribute "**CALIBRATE**" is enabled, the GFC7002T/GFC7002TU will not recalibrate the analyzer until the contact is opened. At this point, the new calibration values will be recorded before the instrument returns to **Sample Mode**.

If the AutoCal attribute "**CALIBRATE**" is disabled, the instrument will return to **Sample Mode**, leaving the instrument's internal calibration variables unchanged.

9.3. AUTOMATIC ZERO/SPAN CAL/CHECK (AUTOCAL)

The AutoCal system allows unattended periodic operation of the **ZERO/SPAN** valve options by using the GFC7002T/GFC7002TU Analyzer's internal time of day clock. AutoCal operates by executing **SEQUENCES** programmed by the user to initiate the various calibration modes of the analyzer and open and close valves appropriately. It is possible to program and run up to three separate sequences (**SEQ1**, **SEQ2** and **SEQ3**). Each sequence can operate in one of three modes, or be disabled.

Table 9-1: AUTOCAL Modes

MODE NAME	ACTION
DISABLED	Disables the Sequence.
ZERO	Causes the Sequence to perform a Zero calibration/check.
ZERO-SPAN	Causes the Sequence to perform a Zero point calibration/check followed by a Span point calibration/check.
SPAN	Causes the Sequence to perform a Span concentration calibration/check only.

For each mode, there are seven parameters that control operational details of the SEQUENCE (see Table 9-2).

Table 9-2: AutoCal Attribute Setup Parameters

ATTRIBUTE	ACTION
TIMER ENABLED	Turns on the Sequence timer.
STARTING DATE	Sequence will operate after Starting Date.
STARTING TIME	Time of day sequence will run.
DELTA DAYS	Number of days to skip between each Sequence execution. <ul style="list-style-type: none"> If set to 7, for example, the AutoCal feature will be enabled once every week on the same day.
DELTA TIME	Number of hours later each "Delta Days" Seq is to be run. <ul style="list-style-type: none"> If set to 0, the sequence will start at the same time each day. Delta Time is added to Delta Days for the total time between cycles. This parameter prevents the analyzer from being calibrated at the same daytime of each calibration day and prevents a lack of data for one particular daytime on the days of calibration.
DURATION	Number of minutes the sequence operates. <ul style="list-style-type: none"> This parameter needs to be set such that there is enough time for the concentration signal to stabilize. The STB parameter shows if the analyzer response is stable at the end of the calibration. This parameter is logged with calibration values in the DAS.
CALIBRATE	Enable to do a calibration – Disable to do a cal check only. <ul style="list-style-type: none"> This setting must be OFF for analyzers used in US EPA applications and with internal span gas generators installed and functioning.
RANGE TO CAL	LOW calibrates the low range, HIGH calibrates the high range. Applies only to auto and remote range modes; this property is not available in single and independent range modes.

Note

The CALIBRATE attribute (formerly called "dynamic calibration") must always be set to OFF for analyzers used in US EPA controlled applications that have internal span gas generators option installed.

Calibration of instruments used in US EPA related applications should only be performed using external sources of zero air and span gas with an accuracy traceable to EPA or NIST standards and supplied through the analyzer's sample port..

The following example sets sequence #2 to do a zero-span calibration every other day starting at 2:15 PM on September 4, 2008, lasting 15 minutes, without calibration. This will start 1/2 hour later each iteration.

Table 9-3: Example AutoCal Sequence

MODE AND ATTRIBUTE	VALUE	COMMENT
SEQUENCE	2	Define Sequence #2
MODE	ZERO-SPAN	Select Zero and Span Mode
TIMER ENABLE	ON	Enable the timer
STARTING DATE	Sept. 4, 2008	Start after Sept 4, 2008
STARTING TIME	14:15	First Span starts at 2:15 PM
DELTA DAYS	2	Do Sequence #2 every other day
DELTA TIME	00:30	Do Sequence #2 ½ hr later each day
DURATION	30.0	Operate Span valve for 15 min
CALIBRATE	ON	Calibrate at end of Sequence

IMPORTANT

IMPACT ON READINGS OR DATA

The programmed **STARTING_TIME** must be a minimum of 5 minutes later than the real time clock for setting real time clock (See Section 5.6.4).

Avoid setting two or more sequences at the same time of the day. Any new sequence that is initiated whether from a timer, the COM ports or the contact closure inputs will override any sequence that is in progress.

IMPORTANT

IMPACT ON READINGS OR DATA

With **CALIBRATE** turned ON, the state of the internal setup variables **DYN_SPAN** and **DYN_ZERO** is set to ON and the instrument will reset the slope and offset values for the N₂O response each time the AutoCal program runs.

This continuous readjustment of calibration parameters can often mask subtle fault conditions in the analyzer. It is recommended that, if **CALIBRATE** is enabled, the analyzer's test functions, slope and offset values be checked frequently to assure high quality and accurate data from the instrument.

9.3.1. SETUP → ACAL: PROGRAMMING AND AUTO CAL SEQUENCE

Note

If at any time an illegal entry is selected, (for example: Delta Days > 366) the ENTR label will disappear from the control button.

To program the example sequence shown in Table 9-3, press:

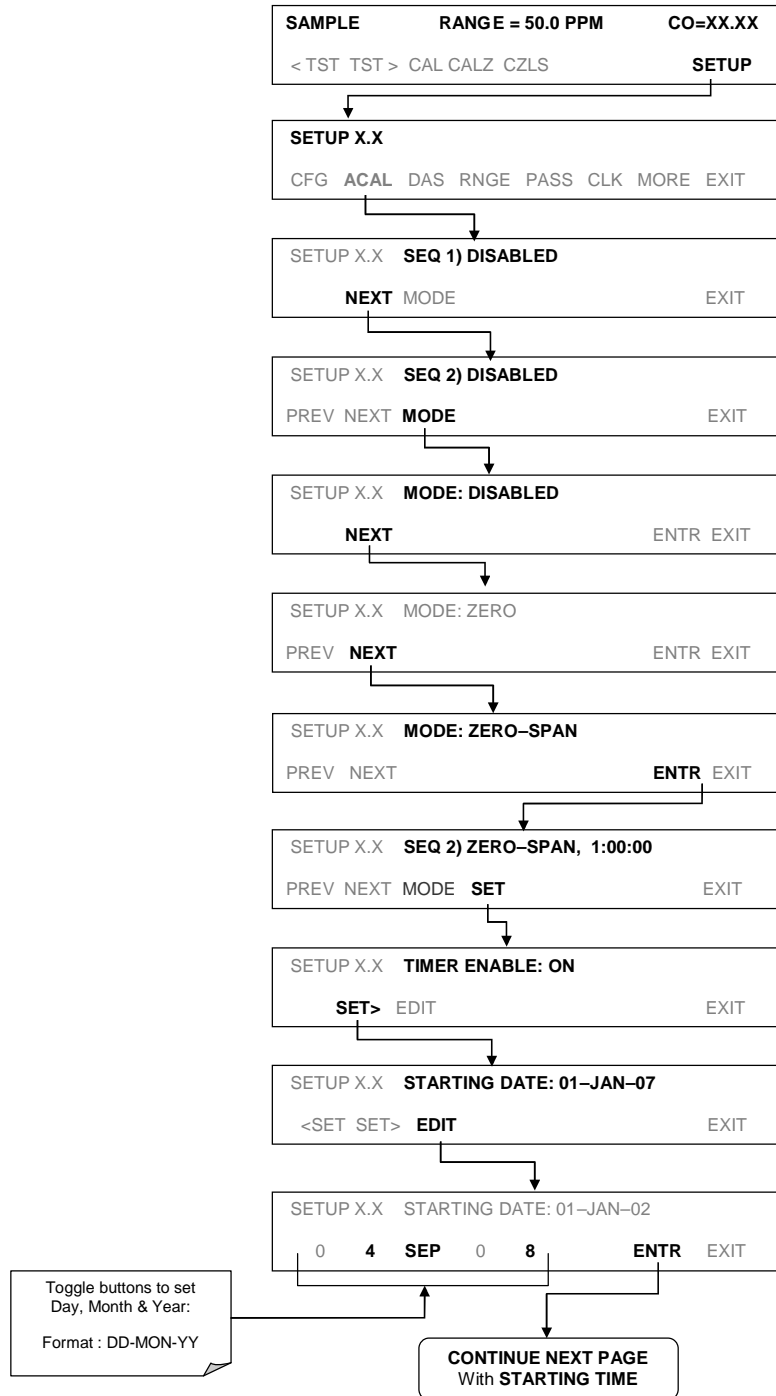

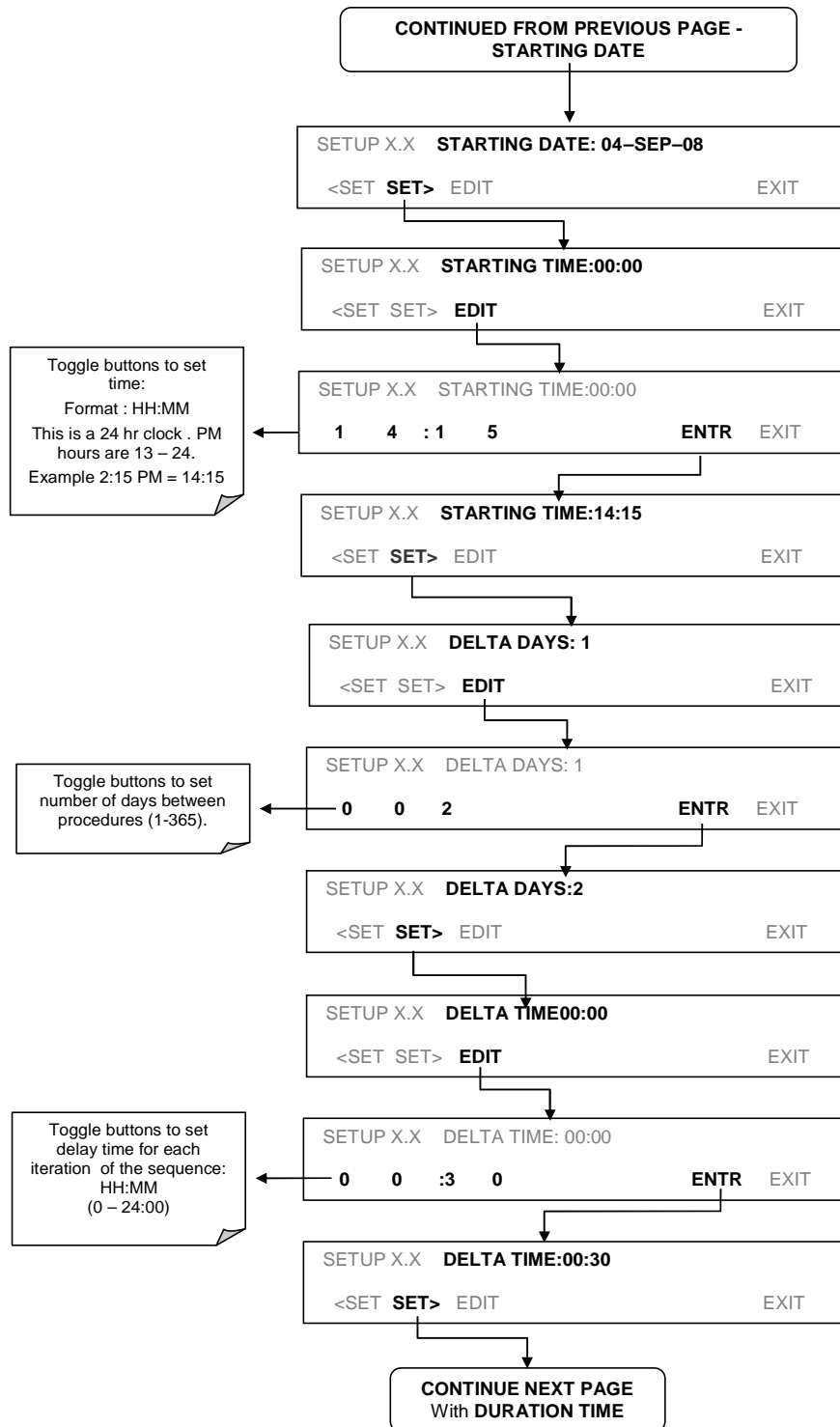

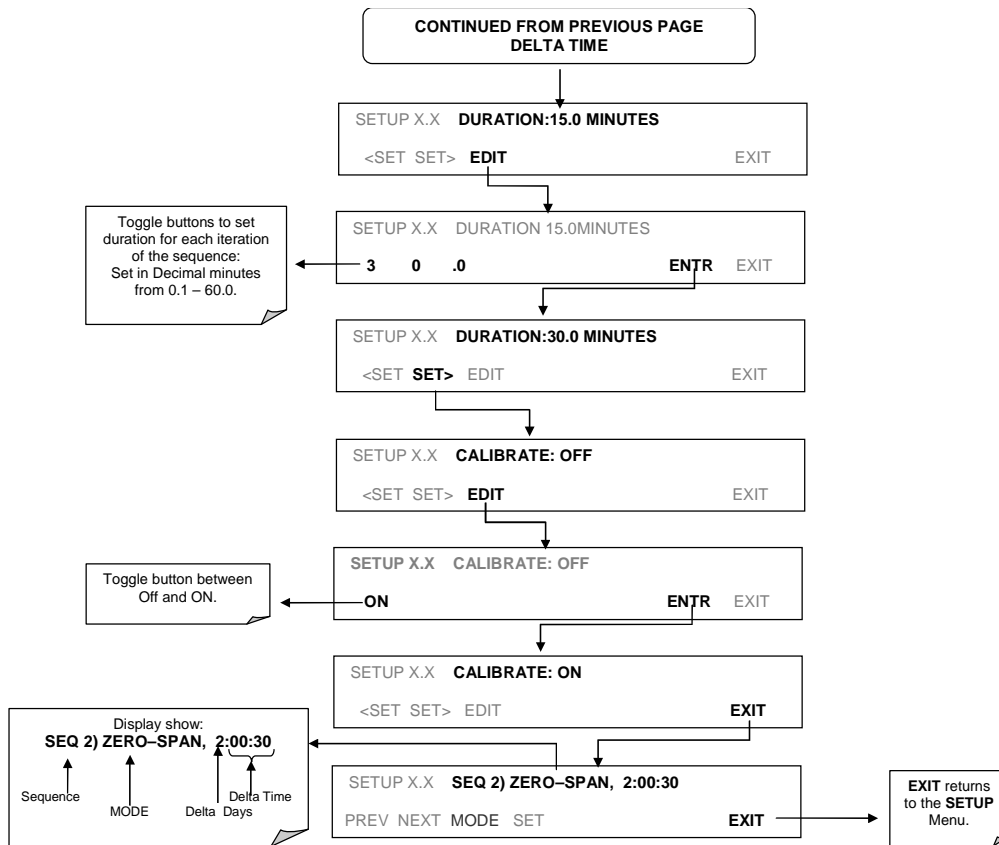

Note: The above screen(s) show CO concentration displayed. Your instrument will indicate and display N₂O concentration.

9.3.1.1. AUTOCAL WITH AUTO OR DUAL REPORTING RANGES MODES SELECTED

If the GFC7002T/GFC7002TU Analyzer is set for either the Dual or Auto reporting range modes, the following three steps will appear at the beginning of the AutoCal setup routine:

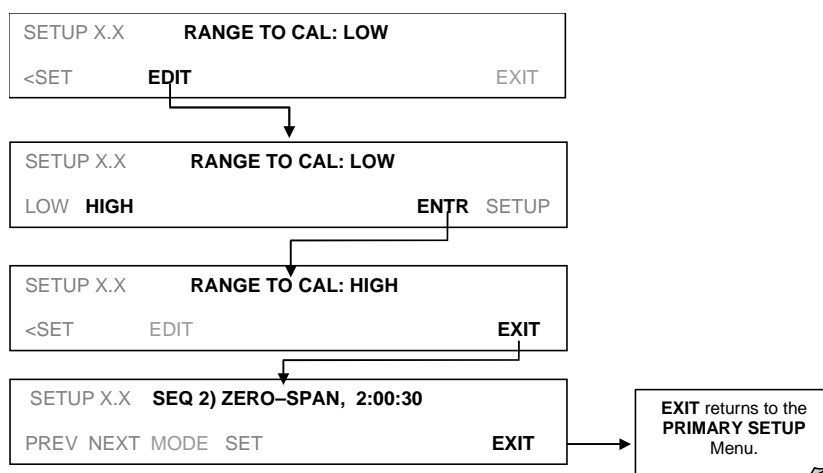

Note: The above screen(s) show CO concentration displayed. Your instrument will indicate and display N₂O concentration.

Note

In order to automatically calibrate both the HIGH and LOW ranges, you must set up a separate sequence for each.

9.4. N₂O CALIBRATION QUALITY

After completing one of the calibration procedures described above, it is important to evaluate the analyzer’s calibration **SLOPE** and **OFFSET** parameters. These values describe the linear response curve of the analyzer. The values for these terms, both individually and relative to each other, indicate the quality of the calibration.

To perform this quality evaluation, you will need to record the values of both test functions (see Section 3.4.3 or Appendix A-3), all of which are automatically stored in the DAS channel CALDAT for data analysis, documentation and archival.

Make sure that these parameters are within the limits listed below and frequently compare them to those values on the *Final Test and Validation Data Sheet* that came attached to your manual, which should not be significantly different. If they are, refer to the Troubleshooting Section 10.

Table 9-4: Calibration Data Quality Evaluation

FUNCTION	MINIMUM VALUE	OPTIMUM VALUE	MAXIMUM VALUE
SLOPE	0.700	1.000	1.300
OFFS	-0.500	0.000	0.500

These values should not be significantly different from the values recorded on the Teledyne *Final Test and Validation Data Sheet* that was shipped with your instrument.

If they are, refer to the troubleshooting Section 10.

The default DAS configuration records all calibration values in channel CALDAT as well as all calibration check (zero and span) values in its internal memory.

- Up to 200 data points are stored for up to 4 years of data (on weekly calibration checks) and a lifetime history of monthly calibrations.

- Review these data to see if the zero and span responses change over time.
- These channels also store the **STABIL** value (standard deviation of N₂O concentration) to evaluate if the analyzer response has properly leveled off during the calibration procedure.
- Finally, the **CALDAT** channel also stores the converter efficiency for review and documentation.

If your instrument has either an O₂ or CO₂ sensor option installed these should be calibrated as well.

9.5. CALIBRATION OF THE GFC7002T/GFC7002TU ELECTRONIC SUBSYSTEMS

9.5.1. DARK CALIBRATION TEST

The dark calibration test interrupts the signal path between the IR photo-detector and the remainder of the sync/demod board circuitry. This allows the instrument to compensate for any voltage levels inherent in the sync/demod circuitry that might effect the calculation of N₂O concentration.

Performing this calibration returns two offset voltages, one for **N2O MEAS** and one for **N2O REF** that are automatically added to the CPU's calculation routine. The two offset voltages from the last calibration procedure may be reviewed by the user via the front panel display. (See also Section 5.8.5).

To activate the dark calibration procedure or review the results of a previous calibration, press:

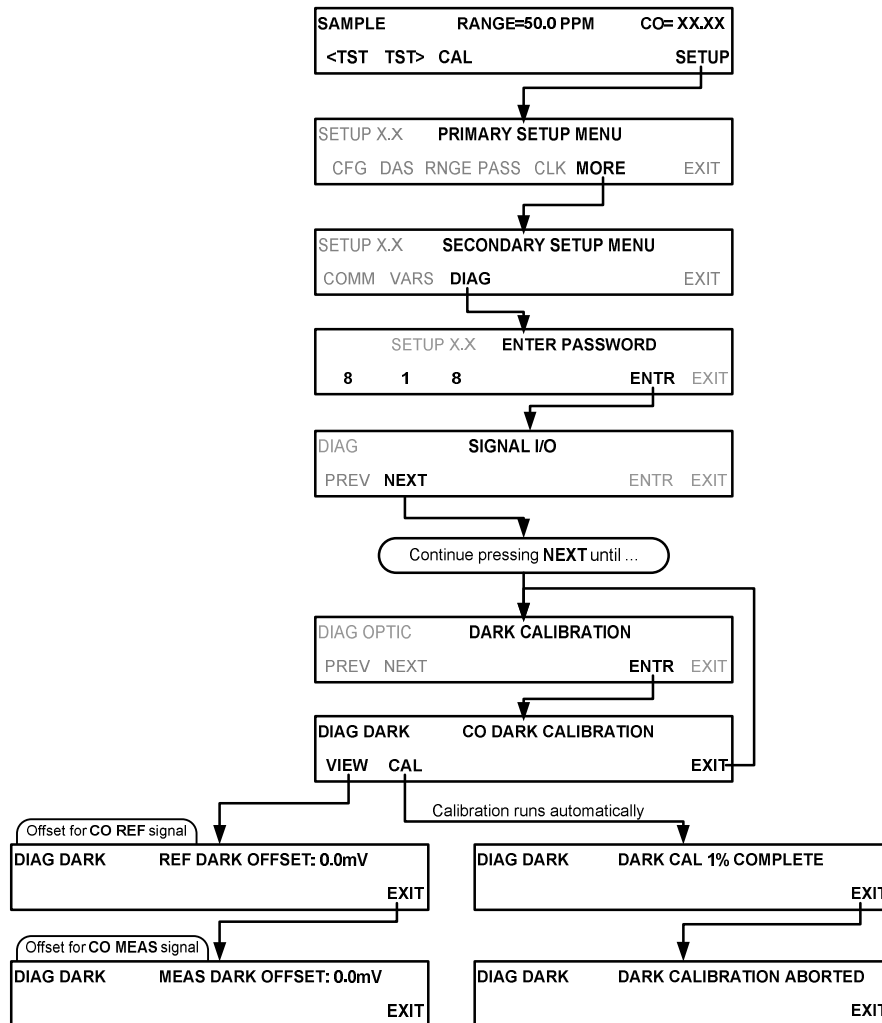

Note: The above screen(s) show CO concentration displayed. Your instrument will indicate and display N₂O concentration.

9.5.2. PRESSURE CALIBRATION

A sensor at the sample chamber outlet continuously measures the pressure of the sample gas. These data are used to compensate the final N₂O concentration calculation for changes in atmospheric pressure and is stored in the CPU's memory as the test function **PRES** (also viewable via the front panel). See also Section 5.8.6.

IMPORTANT

IMPACT ON READINGS OR DATA

This calibration must be performed when the pressure of the sample gas is equal to ambient atmospheric pressure. Before performing the following pressure calibration procedure disconnect the sample gas-line vent from the rear panel sample gas inlet.

To cause the analyzer to measure and record a value for PRES, press.

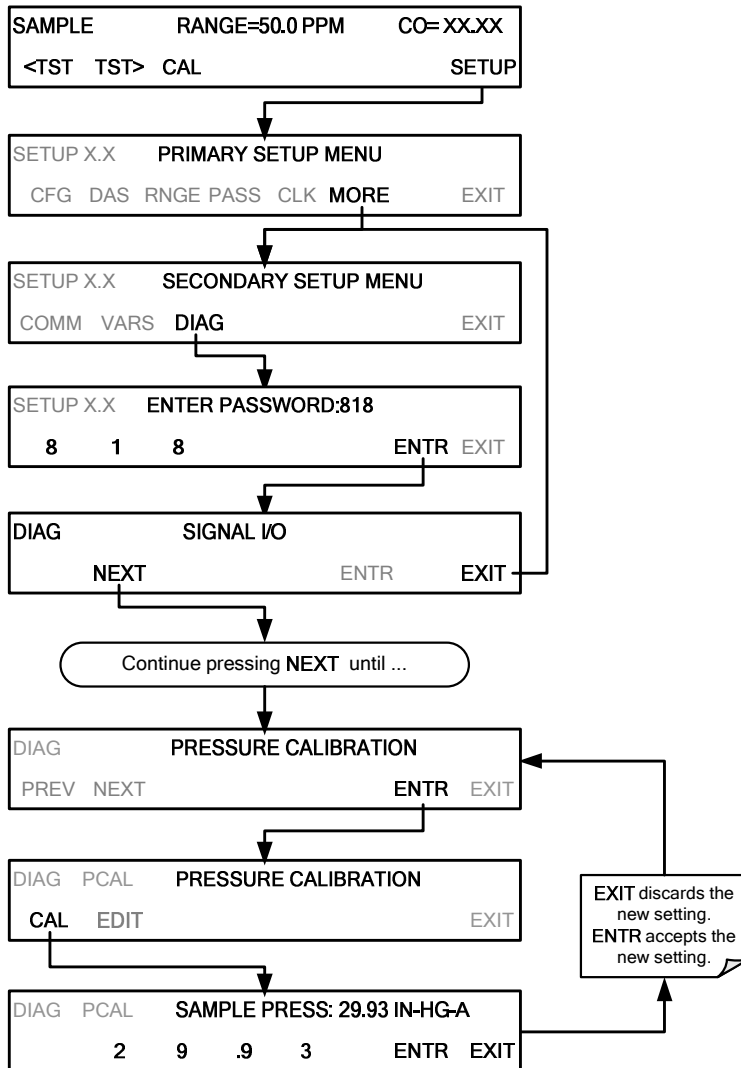

Note: The above screen(s) show CO concentration displayed. Your instrument will indicate and display N₂O concentration.

9.5.3. FLOW CALIBRATION

The flow calibration allows the user to adjust the values of the sample flow rates as they are displayed on the front panel and reported through COMM ports to match the actual flow rate measured at the sample inlet. This does not change the hardware measurement of the flow sensors, only the software-calculated values.

To carry out this adjustment, connect an external, sufficiently accurate flow meter to the sample inlet (see Section 10.3.3 for more details). Once the flow meter is attached and is measuring actual gas flow, press:

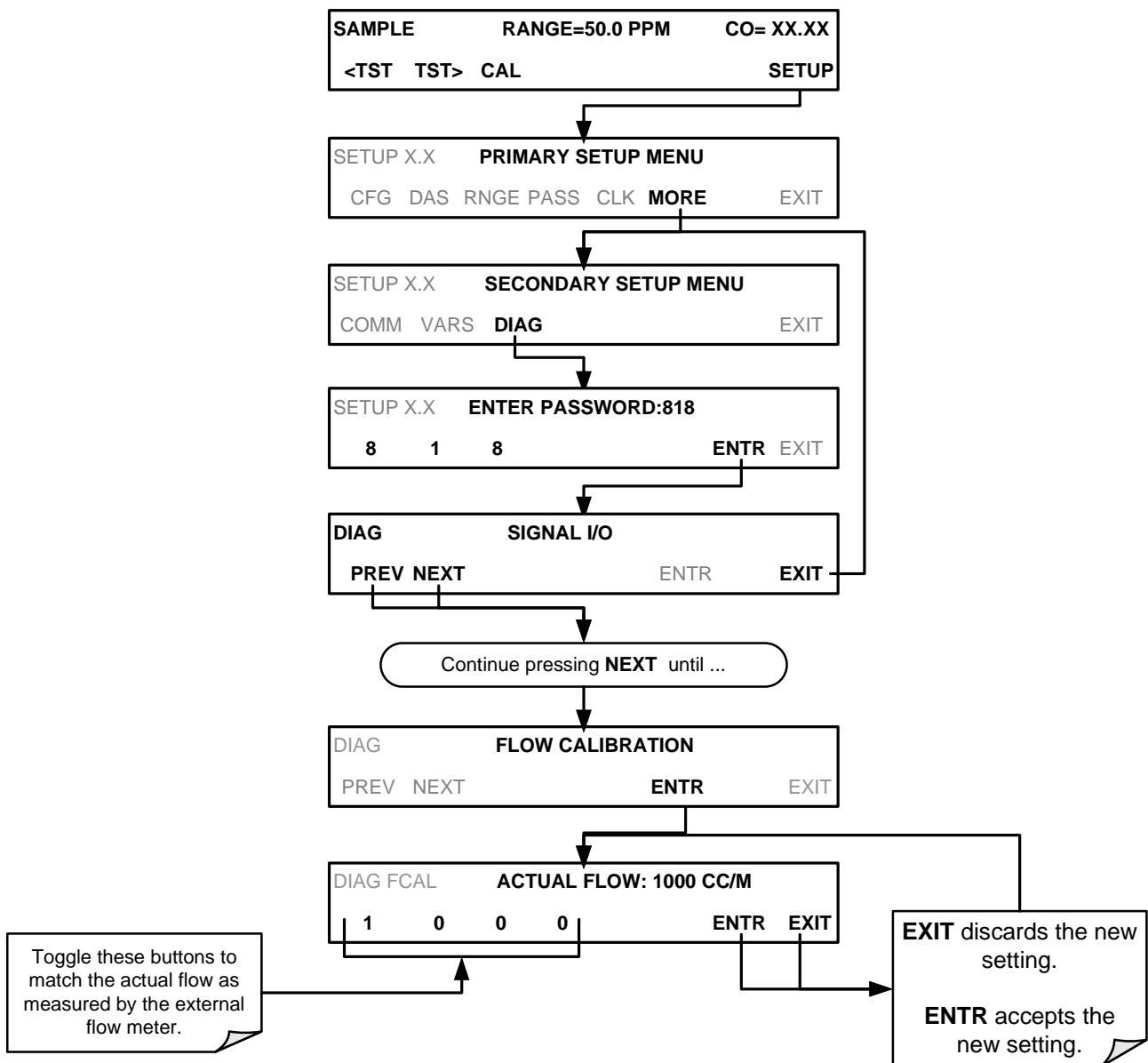

See also Section 5.8.7.

Note: The above screen(s) show CO concentration displayed. Your instrument will indicate and display N₂O concentration.

9.6. CALIBRATION OF OPTIONAL SENSORS

This section provides the calibration setup and procedures for the O₂ Sensor and the CO₂ Sensor options. Refer to any addenda accompanying this manual for custom configuration information.

9.6.1. O₂ SENSOR CALIBRATION

Presented here are first the setup and then the calibration steps for the O₂ Sensor.

9.6.1.1. O₂ PNEUMATICS CONNECTIONS

The pneumatic connections for calibrating are as follows:

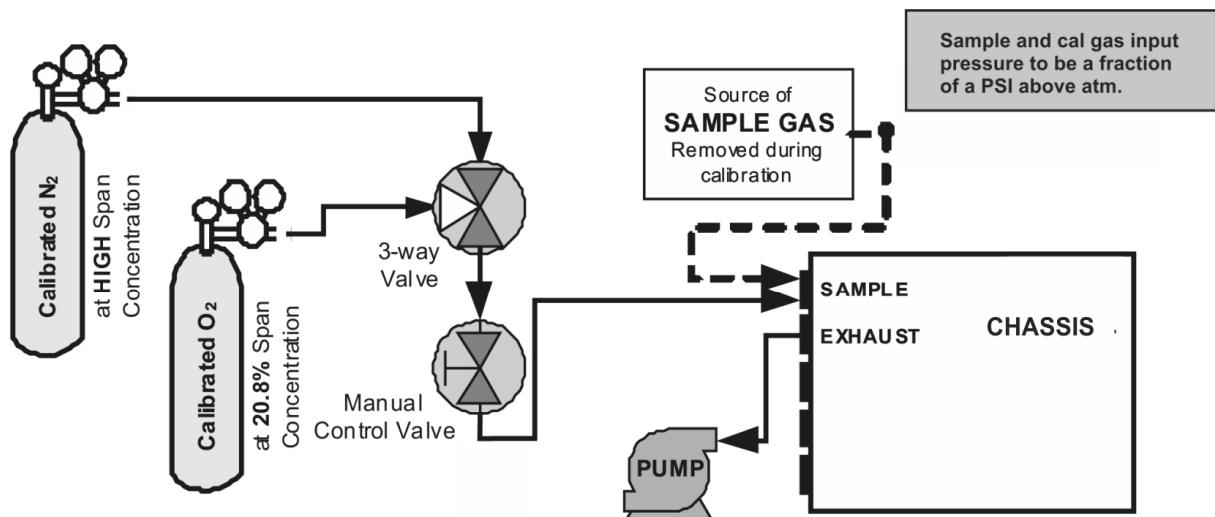

Figure 9-6: O₂ Sensor Calibration Set Up

O₂ SENSOR ZERO GAS: TAI recommends using pure N₂ when calibration the zero point of your O₂ sensor option.

O₂ SENSOR SPAN GAS: TAI recommends using 20.8% O₂ in N₂ when calibration the span point of your O₂ sensor option (See **Error! Reference source not found.**).

9.6.1.2. SET O₂ SPAN GAS CONCENTRATION

Set the expected O₂ span gas concentration.

This should be equal to the percent concentration of the O₂ span gas of the selected reporting range (default factory setting = 20.8%; the approximate O₂ content of ambient air).

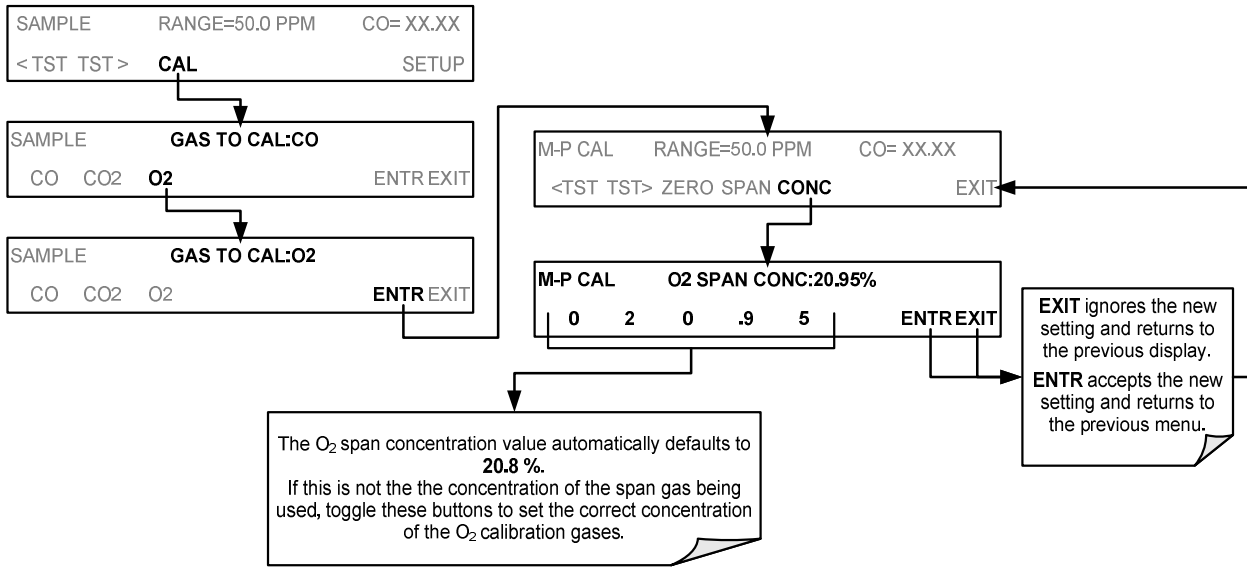

Note: The above screen(s) show CO concentration displayed. Your instrument will indicate and display N₂O concentration.

9.6.1.3. ACTIVATE O₂ SENSOR STABILITY FUNCTION

To change the stability test function from N₂O concentration to the O₂ sensor output, press:

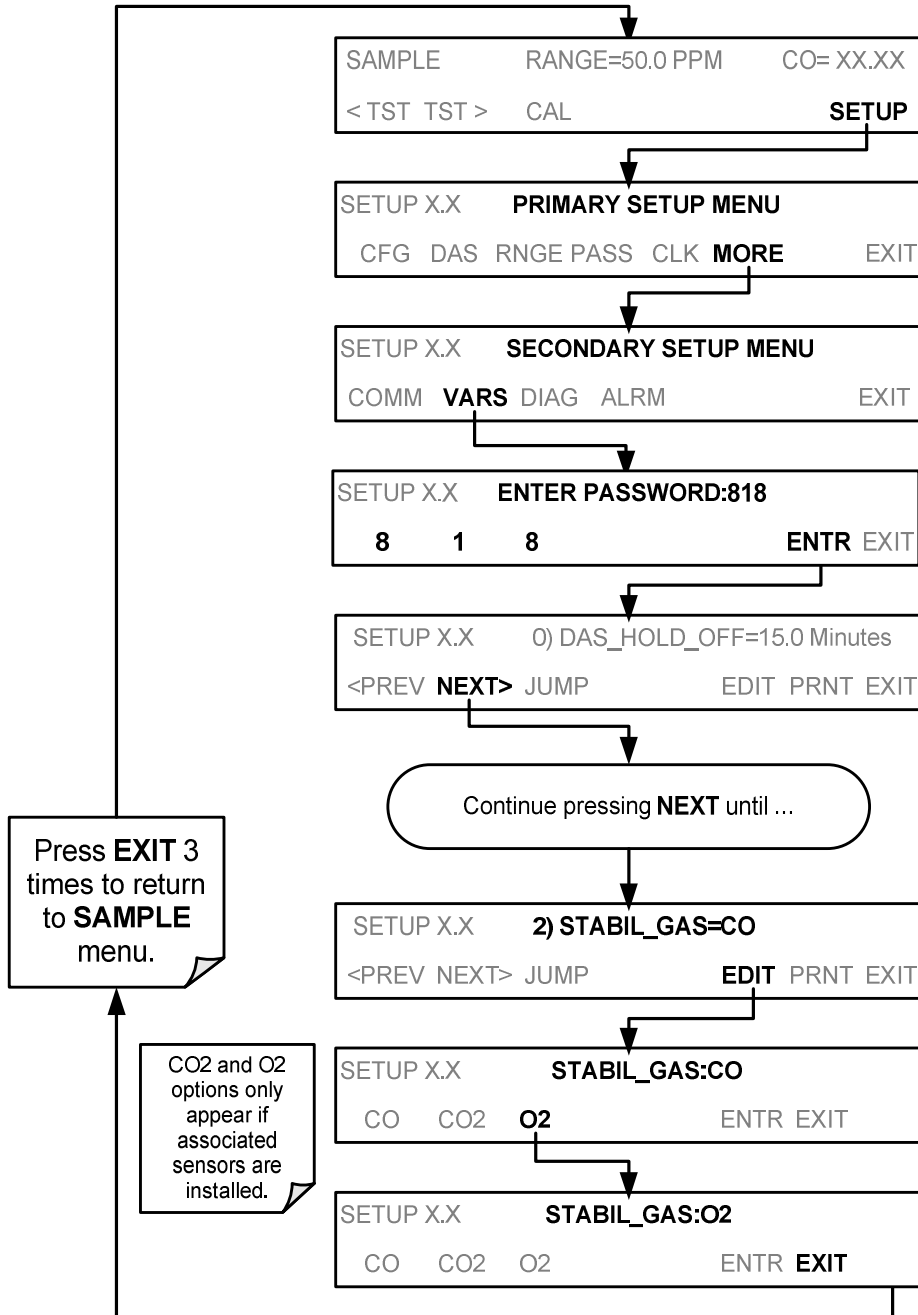

Note: The above screen(s) show CO concentration displayed. Your instrument will indicate and display N₂O concentration.

Note

Use the same procedure to reset the STB test function to N₂O when the O₂ calibration procedure is complete.

9.6.1.4. O₂ ZERO/SPAN CALIBRATION

To perform the zero/span calibration procedure:

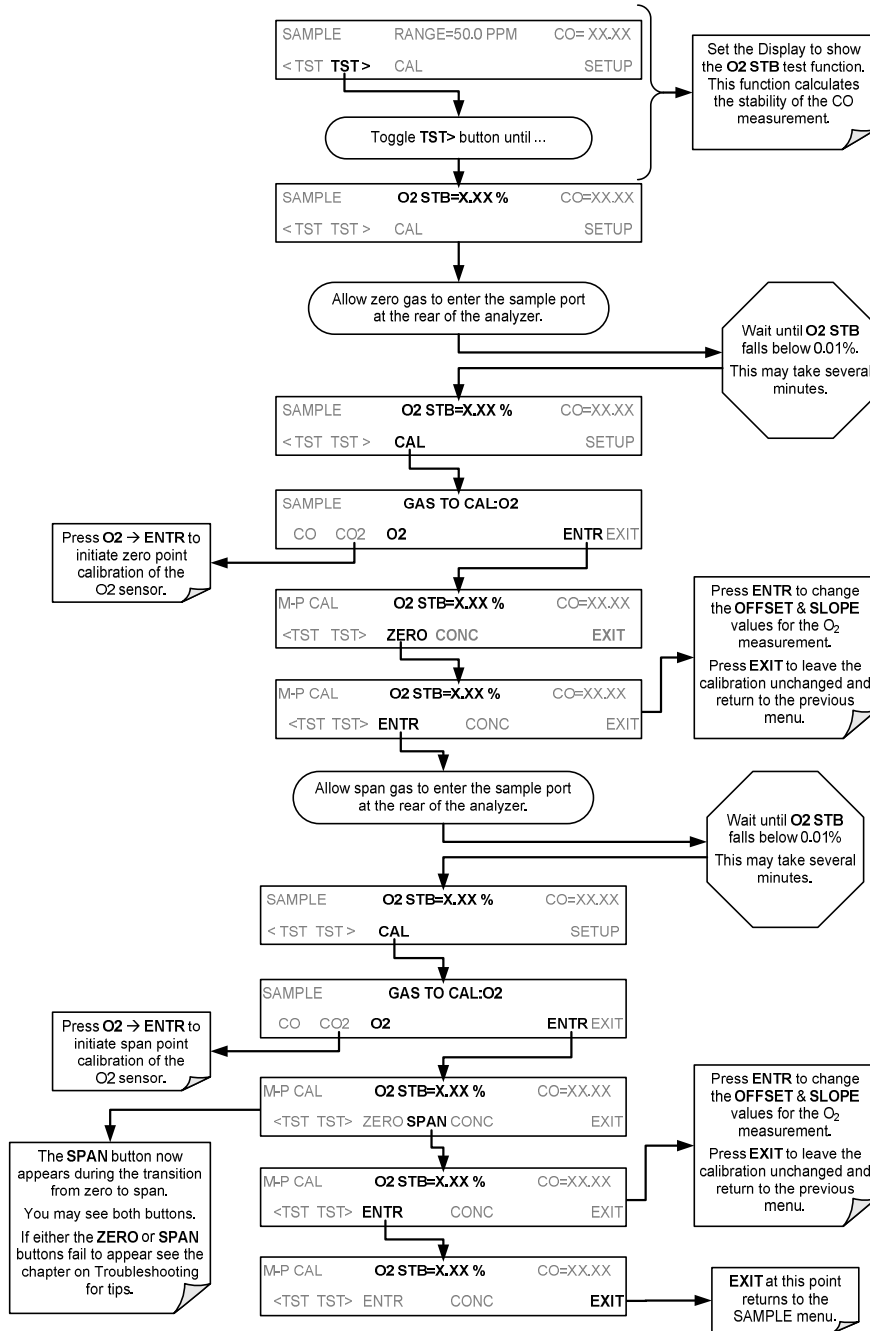

Note: The above screen(s) show CO concentration displayed. Your instrument will indicate and display N₂O concentration.

9.6.2. CO₂ SENSOR CALIBRATION PROCEDURE

Presented here are first the setup and then the calibration steps for the CO₂ Sensor.

9.6.2.1. CO₂ PNEUMATICS CONNECTIONS

The pneumatic connections for calibrating are as follows

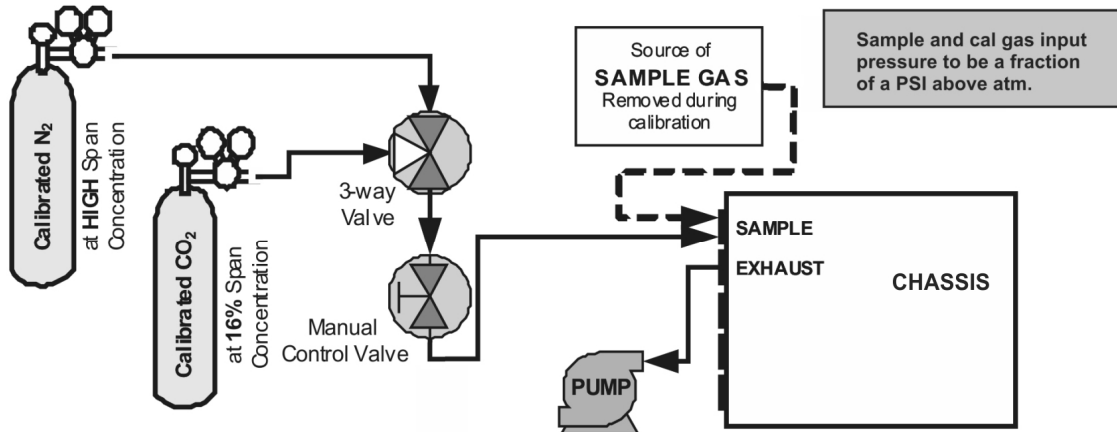

Figure 9-7: CO₂ Sensor Calibration Set Up

CO₂ SENSOR ZERO GAS: TAI recommends using pure N₂ when calibration the zero point of your CO₂ sensor option.

CO₂ SENSOR SPAN GAS: TAI recommends using 16% CO₂ in N₂ when calibration the span point of your CO₂ sensor option (**Error! Reference source not found.**) is 20%.

9.6.2.2. SET CO₂ SPAN GAS CONCENTRATION:

Set the expected CO₂ span gas concentration.

This should be equal to the percent concentration of the CO₂ span gas of the selected reporting range (default factory setting = 12%).

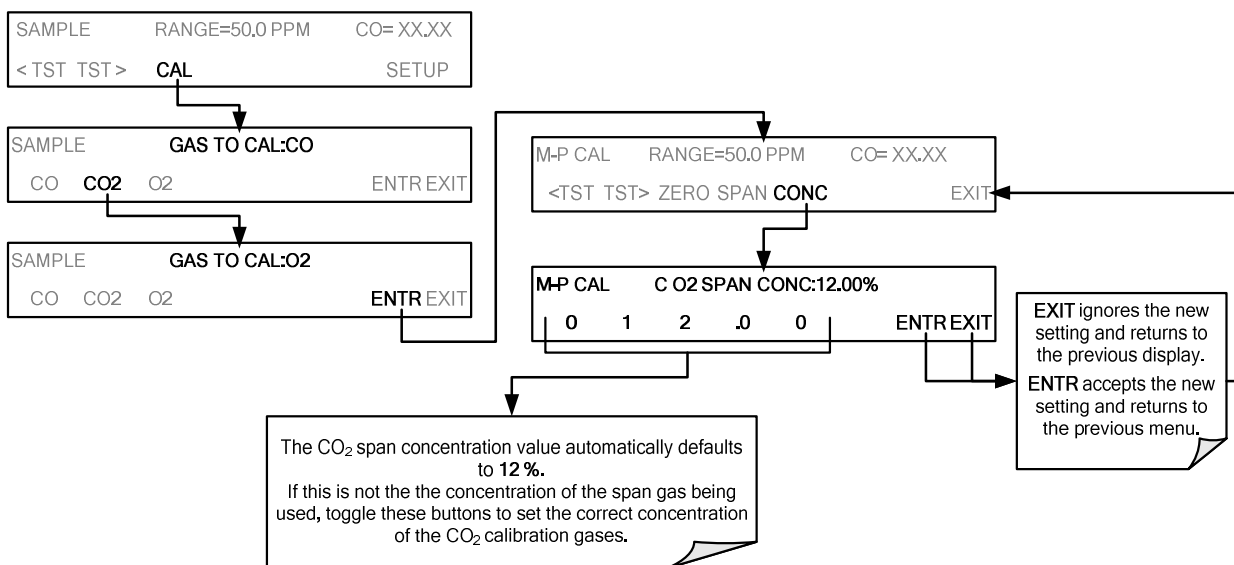

Note: The above screen(s) show CO concentration displayed. Your instrument will indicate and display N₂O concentration.

9.6.2.3. ACTIVATE CO2 SENSOR STABILITY FUNCTION

To change the stability test function from N₂O concentration to the CO₂ sensor output, press:

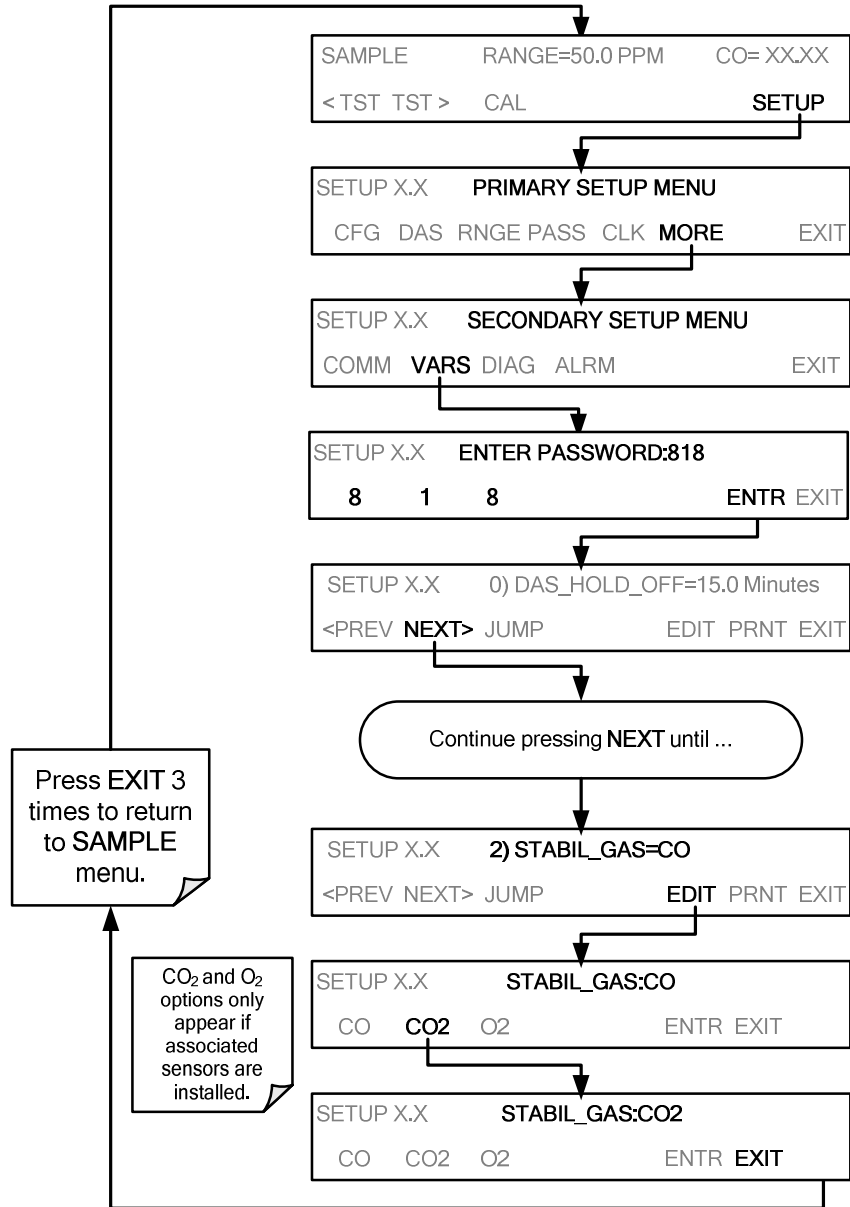

Note: The above screen(s) show CO concentration displayed. Your instrument will indicate and display N₂O concentration.

Note

Use the same procedure to reset the STB test function to N₂O when the CO₂ calibration procedure is complete.

9.6.2.4. CO2 ZERO/SPAN CALIBRATION

To perform the zero/span calibration procedure:

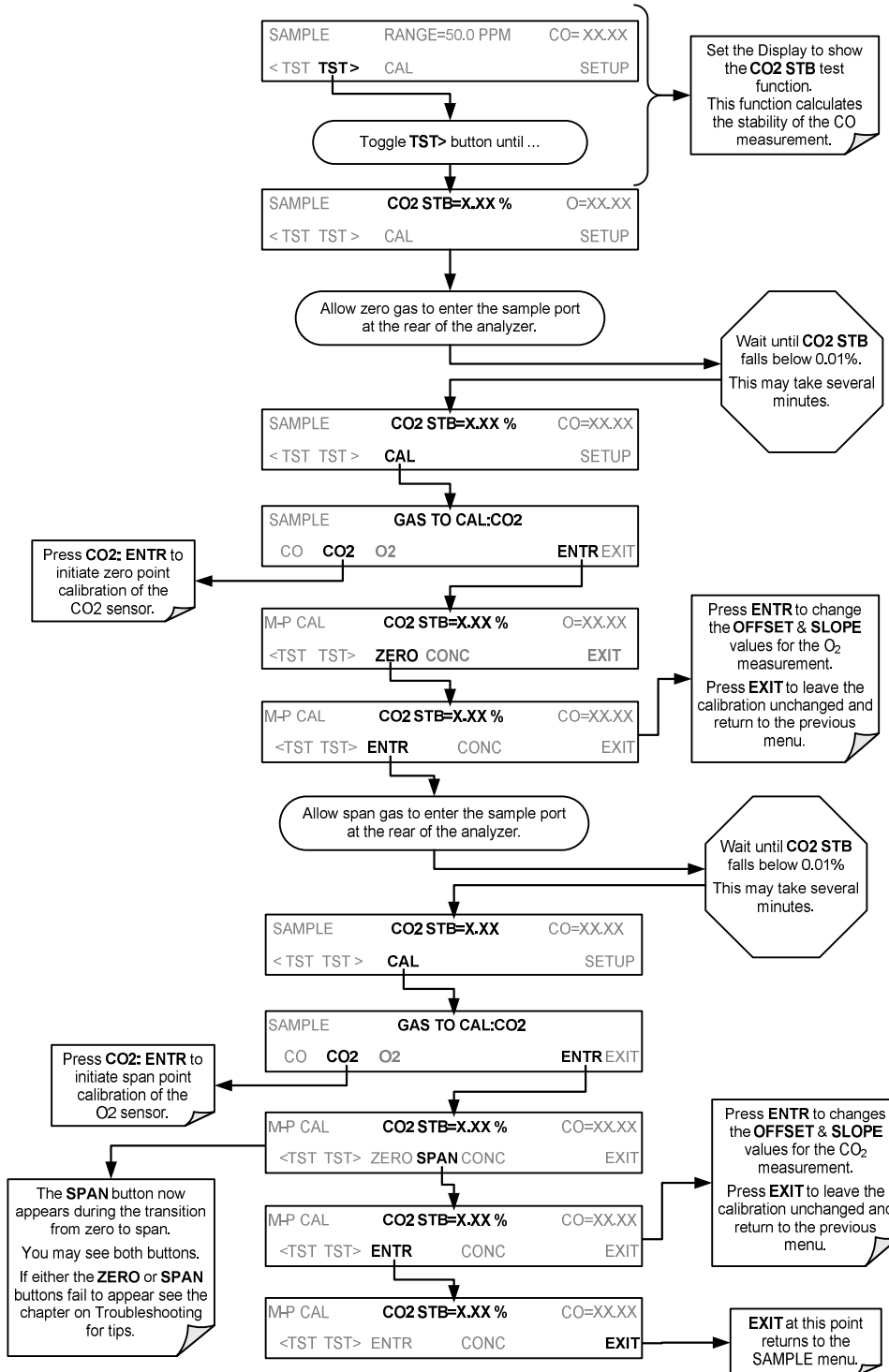

Note: The above screen(s) show CO concentration displayed. Your instrument will indicate and display N₂O concentration.

This page intentionally left blank.

PART III
TECHNICAL INFORMATION

This page intentionally left blank.

10. MAINTENANCE SCHEDULE & PROCEDURES

Predictive diagnostic functions, including data acquisition records, failure warnings and test functions built into the analyzer, allow the user to determine when repairs are necessary without performing painstaking preventative maintenance procedures. There are, however, a minimal number of simple procedures that when performed regularly will ensure that the analyzer continues to operate accurately and reliably over its lifetime. Repairs and troubleshooting are covered in Section 11 of this manual.

10.1. MAINTENANCE SCHEDULE

Table 10-1 shows a typical maintenance schedule for the analyzer. Please note that in certain environments (i.e. dusty, very high ambient pollutant levels) some maintenance procedures may need to be performed more often than shown.

Note

A Span and Zero Calibration Check (see CAL CHECK REQ'D Column of Table 10 1) must be performed following certain of the maintenance procedure listed below.

See Sections 8.3 and 8.4 for instructions on performing checks.



**CAUTION
GENERAL SAFETY HAZARD**

Risk of electrical shock. Disconnect power before performing any of the following operations that require entry into the interior of the analyzer.

This page intentionally left blank.



**CAUTION
QUALIFIED PERSONNEL**

The operations outlined in this section are to be performed by qualified maintenance personnel only.

Table 10-1: GFC7002T/GFC7002TU Maintenance Schedule

ITEM	ACTION	FREQ	CAL CHECK REQ'D	MANUAL	DATE PERFORMED										
Particulate Filter	Replace	Weekly or As Needed	No												
Verify Test Functions	Record and Analyze	Weekly or after any Maintenance or Repair	No												
Perform Flow Check	Check Flow	Annually	No												
Perform Leak Check	Verify Leak Tight	Annually or after any Maintenance or Repair	No												
Pneumatic lines	Examine and Clean	As Needed	Yes if cleaned												
Cleaning	Clean	As Needed	Only if cover removed												

Table 10-2: GFC7002T/GFC7002TU Test Function Record

FUNCTION	OPERATING MODE*	DATE RECORDED											
STABILITY	ZERO CAL												
N2O MEAS	ZERO CAL												
MR RATIO	ZERO CAL												
	SPAN CAL												
PRES	SAMPLE												
PHT DRIVE	SAMPLE AFTER WARM-UP												
SLOPE	SPAN CAL												
OFFSET	ZERO CAL												

10.2. PREDICTING FAILURES USING THE TEST FUNCTIONS

The Test Functions can be used to predict failures by looking at how their values change over time. Initially it may be useful to compare the state of these Test Functions to the values recorded on the printed record of the final calibration performed on your instrument at the factory, P/N 04307. Table 10-3 can be used as a basis for taking action as these values change with time. The internal data acquisition system (DAS) is a convenient way to record and track these changes. Use APICOM to download and review this data from a remote location.

Table 10-3: Predictive uses for Test Functions

FUNCTION	CONDITION	BEHAVIOR	INTERPRETATION
STABILITY	Zero Cal	Increasing	<ul style="list-style-type: none"> • Pneumatic Leaks – instrument & sample system • Detector deteriorating
N ₂ O MEAS	Zero Cal	Decreasing	<ul style="list-style-type: none"> • Source Aging • Detector deteriorating • Optics getting dirty or contaminated
MR RATIO	Zero Cal	Increasing	<ul style="list-style-type: none"> • Source Aging • Detector deteriorating • Contaminated zero gas (H₂O)
		Decreasing	<ul style="list-style-type: none"> • Source Aging • Detector deteriorating • GFC Wheel Leaking • Pneumatic Leaks • Contaminated zero gas (N₂O)
	Span Cal	Increasing	<ul style="list-style-type: none"> • Source Aging • Pneumatic Leaks – instrument & sample system • Calibration system deteriorating • GFC Wheel Leaking
		Decreasing	<ul style="list-style-type: none"> • Source Aging • Calibration system deteriorating
PRES	Sample	Increasing > 1"	<ul style="list-style-type: none"> • Pneumatic Leak between sample inlet and Sample Cell • Change in sampling manifold
		Decreasing > 1"	<ul style="list-style-type: none"> • Dirty particulate filter • Pneumatic obstruction between sample inlet and Sample Cell • Obstruction in sampling manifold
PHT DRIVE	Any, but with Bench Temp at 48°C	Increasing	<ul style="list-style-type: none"> • Mechanical Connection between IR-Detector and Sample Cell deteriorating • IR-Photodetector deteriorating
OFFSET	Zero Cal	Increasing	• See <u>MR Ratio - Zero Cal Decreasing</u> above
		Decreasing	• See <u>MR Ratio - Zero Cal Increasing</u> above
SLOPE	Span Cal	Increasing	• See <u>MR Ratio - Span Cal Decreasing</u> above
		Decreasing	• See <u>MR Ratio – Span Cal Increasing</u> above

10.3. MAINTENANCE PROCEDURES

The following procedures are to be performed periodically as part of the standard maintenance of the GFC7002T.

10.3.1. REPLACING THE SAMPLE PARTICULATE FILTER

The particulate filter should be inspected often for signs of plugging or contamination. We recommend that the filter and the wetted surfaces of the filter housing are handled as little as possible when you change the filter. Do not touch any part of the housing, filter element, PTFE retaining ring, glass cover and the O-ring.

To change the filter:

1. Turn OFF the analyzer to prevent drawing debris into the instrument.
2. Open the GFC7002T Analyzer's hinged front panel and unscrew the knurled retaining ring on the filter assembly.

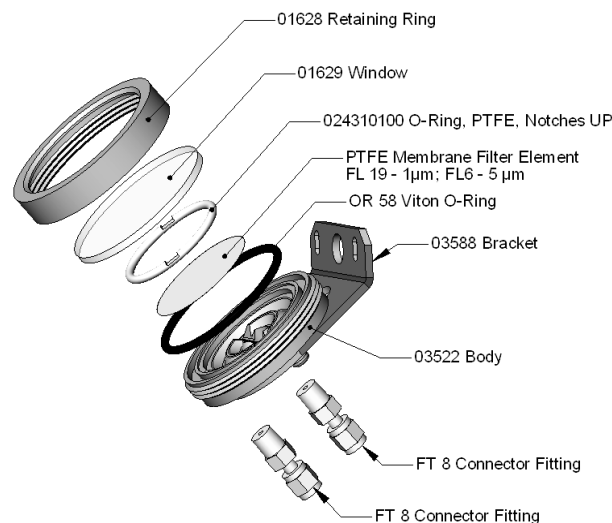

Figure 10-1: Sample Particulate Filter Assembly

3. Carefully remove the retaining ring, PTFE O-ring, glass filter cover and filter element.
4. Replace the filter, being careful that the element is fully seated and centered in the bottom of the holder.
5. Re-install the PTFE O-ring (with the notches up), the glass cover, then screw on the retaining ring and hand tighten. Inspect the seal between the edge of filter and the O-ring to assure a proper seal.
6. Re-start the Analyzer.

10.3.2. PERFORMING LEAK CHECKS

Leaks are the most common cause of analyzer malfunction; Section **Error! Reference source not found.** presents a simple leak check procedure. Section 10.3.2.1 details a more thorough procedure.

10.3.2.1. PRESSURE LEAK CHECK

Obtain a leak checker similar to the TAI P/N 01960, which contains a small pump, shut-off valve and pressure gauge. Alternatively, a convenient source of low-pressure gas is a tank of span gas, with the two-stage regulator adjusted to less than 15 psi with a shutoff valve and pressure gauge.



CAUTION
GENERAL SAFETY HAZARD

Do not use bubble solution with vacuum applied to the analyzer. The solution may contaminate the instrument. Do not exceed 15 PSIG pressure.

1. Turn OFF power to the instrument.
2. Install a leak checker or tank of gas as described above on the sample inlet at the rear panel.
3. Remove the instrument cover and the flow assembly and plug it with the appropriate gas-tight fitting.
4. Pressurize the instrument with the leak checker, allowing enough time to fully pressurize the instrument through the critical flow orifice. Check each fitting with soap bubble solution, looking for bubbles. Once the fittings have been wetted with soap solution, do not re-apply vacuum, as it will suck soap solution into the instrument and contaminate it. Do not exceed 15 psi pressure.
5. If the instrument has one of the zero and span valve options, the normally closed ports on each valve should also be separately checked. Connect the leak checker to the normally closed ports and check with soap bubble solution.
6. Once the leak has been located and repaired, the leak-down rate should be < 1 in-Hg (0.4 psi) in 5 minutes after the pressure is shut off.

10.3.3. PERFORMING A SAMPLE FLOW CHECK



CAUTION
GENERAL SAFETY HAZARD

Always use a separate calibrated flow meter capable of measuring flows in the 0 – 1000 cm³/min range to measure the gas flow rate through the analyzer.

DO NOT use the built in flow measurement viewable from the Front Panel of the instrument. This measurement is only for detecting major flow interruptions such as clogged or plugged gas lines.

See Figure 3-4 for SAMPLE port location.

1. Attach the Flow Meter to the sample inlet port on the rear panel. Ensure that the inlet to the Flow Meter is at atmospheric pressure.
2. Sample flow should be 800 cm³/min ± 10%.

3. Once an accurate measurement has been recorded by the method described above, adjust the analyzer's internal flow sensors (See Section 9.5.3).

Low flows indicate blockage somewhere in the pneumatic pathway, typically a plugged sintered filter or critical flow orifice in one of the analyzer's flow control assemblies. High flows indicate leaks downstream of the Flow Control Assembly.

10.3.4. CLEANING THE OPTICAL BENCH

The GFC7002T/GFC7002TU sensor assembly and optical bench are complex and delicate. Disassembly and cleaning is not recommended. Please check with the factory before disassembling the optical bench.

10.3.5. CLEANING EXTERIOR SURFACES OF THE GFC7002T/GFC7002TU

If necessary, the exterior surfaces of the GFC7002T/GFC7002TU can be cleaned with a clean damp cloth. Do NOT submerge any part of the instrument and do NOT use any cleaning solution.

11. TROUBLESHOOTING AND SERVICE

This contains a variety of methods for identifying the source of performance problems with the analyzer. Also included in this are procedures that are used in repairing the instrument.



NOTE QUALIFIED PERSONNEL

The operations outlined in this section must be performed by qualified maintenance personnel only.



CAUTION GENERAL SAFETY HAZARD

- Risk of electrical shock. Some operations need to be carried out with the instrument open and running.
- Exercise caution to avoid electrical shocks and electrostatic or mechanical damage to the analyzer.
- Do not drop tools into the analyzer or leave those after your procedures.
- Do not shorten or touch electric connections with metallic tools while operating inside the analyzer.
- Use common sense when operating inside a running analyzer.

11.1. GENERAL TROUBLESHOOTING

The GFC7002T/GFC7002TU Carbon Monoxide Analyzer has been designed so that problems can be rapidly detected, evaluated and repaired. During operation, it continuously performs diagnostic tests and provides the ability to evaluate its key operating parameters without disturbing monitoring operations.

A systematic approach to troubleshooting will generally consist of the following five steps:

1. Note any **WARNING MESSAGES** and take corrective action as necessary.
 2. Examine the values of all TEST functions and compare them to factory values. Note any major deviations from the factory values and take corrective action.
 3. Use the internal electronic status LEDs to determine whether the electronic communication channels are operating properly.
- Verify that the DC power supplies are operating properly by checking the voltage test points on the relay PCA.
 - Note that the analyzer's DC power wiring is color-coded and these colors match the color of the corresponding test points on the relay PCA.

4. **SUSPECT A LEAK FIRST!**
 - Customer service data indicate that the majority of all problems are eventually traced to leaks in the internal pneumatics of the analyzer or the diluent gas and source gases delivery systems.
 - Check for gas flow problems such as clogged or blocked internal/external gas lines, damaged seals, punctured gas lines, a damaged / malfunctioning pumps (if equipped), etc.
5. Follow the procedures defined in Section 11.5 to confirm that the analyzer's vital functions are working (power supplies, CPU, relay PCA, touchscreen, PMT cooler, etc.).
 - See Figure 3-6 for the general layout of components and sub-assemblies in the analyzer.
 - See the wiring interconnect diagram and interconnect list in Appendix D.

11.1.1.1. **FAULT DIAGNOSIS WITH WARNING MESSAGES**

The most common and/or serious instrument failures will result in a warning message being displayed on the front panel. Table 11-1 lists warning messages, along with their meaning and recommended corrective action.

It should be noted that if more than two or three warning messages occur at the same time, it is often an indication that some fundamental analyzer sub-system (power supply, relay board, motherboard) has failed rather than an indication of the specific failures referenced by the warnings. In this case, a combined-error analysis needs to be performed.

The analyzer will alert the user that a Warning message is active by flashing the FAULT LED, displaying the the Warning message in the Param field along with the **CLR** button (press to clear Warning message). The **MSG** button displays if there is more than one warning in queue or if you are in the TEST menu and have not yet cleared the message. The following display/touchscreen examples provide an illustration of each:

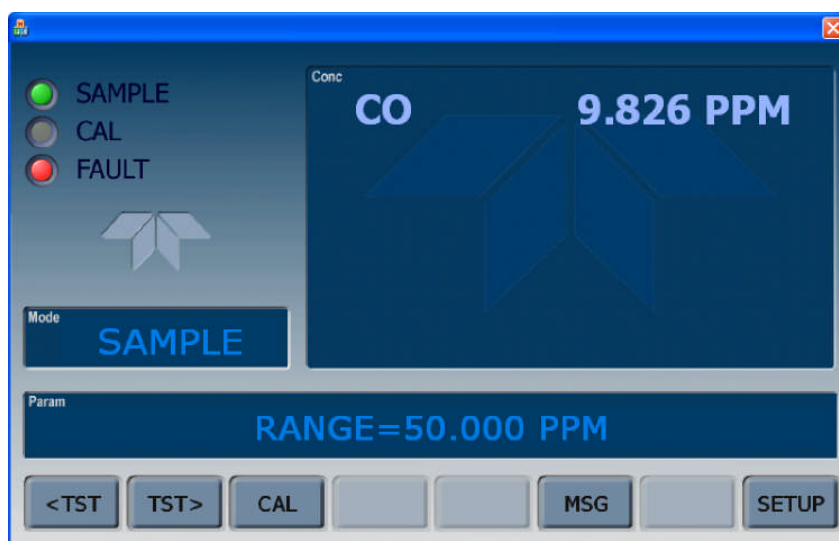
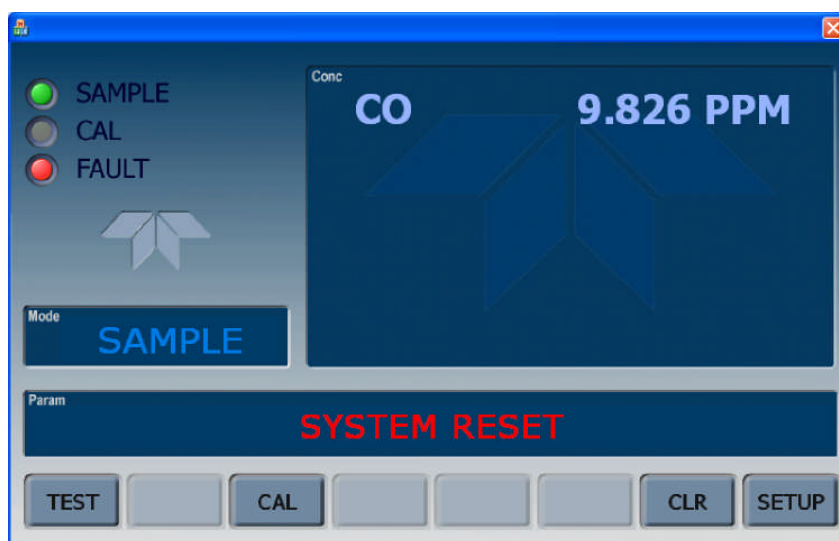

Note: The above screen(s) show CO concentration displayed. Your instrument will indicate and display N₂O concentration.

The analyzer will also alert the user via the Serial I/O COM port(s).
To view or clear the various warning messages press:

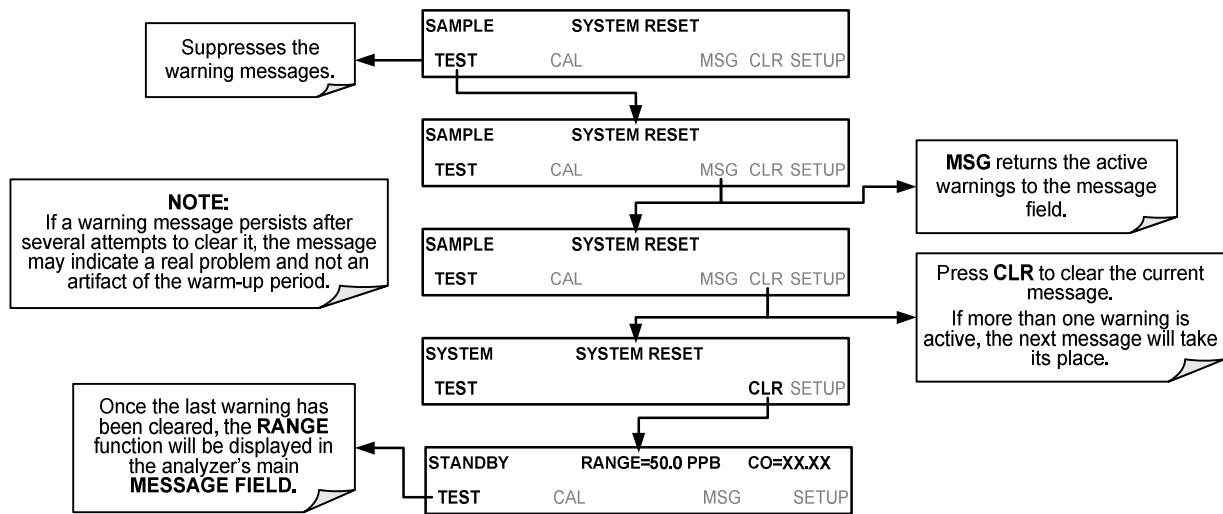

Figure 11-1: Viewing and Clearing Warning Messages

Table 11-1: Warning Messages - Indicated Failures

WARNING MESSAGE	FAULT CONDITION	POSSIBLE CAUSES
BENCH TEMP WARNING	The optical bench temp is controlled at 48 ± 2 °C.	Bad bench heater Bad bench temperature sensor Bad relay controlling the bench heater Entire relay board is malfunctioning I ² C bus malfunction
BOX TEMP WARNING	Box Temp is < 5 °C or > 48 °C.	NOTE: Box temperature typically runs ~7°C warmer than ambient temperature. Poor/blocked ventilation to the analyzer. Stopped exhaust-fan Ambient temperature outside of specified range
CANNOT DYN SPAN	Dynamic Span operation failed	Measured concentration value is too high or low. Concentration slope value to high or too low
CANNOT DYN ZERO	Dynamic Zero operation failed	Measured concentration value is too high. Concentration offset value to high.
CONFIG INITIALIZED	Configuration and Calibration data reset to original Factory state.	Failed disk on module User erased data
DATA INITIALIZED	Data Storage in DAS was erased	Failed disk on module User cleared data
PHOTO TEMP WARNING	PHT DRIVE is >4800 mVDC	Failed IR photo-detector Failed sync/demod board IR photo-detector improperly attached to the sample chamber Bench temp too high.
REAR BOARD NOT DET	Motherboard not detected on power up.	Warning only appears on serial I/O com port(s) Front panel display will be frozen, blank or will not respond. Massive failure of motherboard
RELAY BOARD WARN	The CPU cannot communicate with the Relay Board.	I ² C bus failure Failed relay board Loose connectors/wiring
SAMPLE FLOW WARN	Sample flow rate is < 500 cm ³ /min or > 1000 cm ³ /min.	Blocked sample inlet/gas line Dirty particulate filter Leak downstream of critical flow orifice Failed flow sensor/circuitry

WARNING MESSAGE	FAULT CONDITION	POSSIBLE CAUSES
SAMPLE PRES WARN	Sample Pressure is <10 in-Hg or > 35 in-Hg Normally 29.92 in-Hg at sea level decreasing at 1 in-Hg per 1000 ft of altitude.	If sample pressure is < 10 in-hg: Blocked particulate filter Blocked sample inlet/gas line Failed pressure sensor/circuitry If sample pressure is > 35 in-hg: Pressurized sample gas. Install vent Blocked vent line on pressurized sample/zero/span gas supply Bad pressure sensor/circuitry
SAMPLE TEMP WARN	Sample temperature is < 10°C or > 100°C.	Ambient temperature outside of specified range Failed bench heater Failed bench temperature sensor Relay controlling the bench heater Failed relay board I ² C bus
SOURCE WARNING	Occurs when N ₂ O Ref is <1250 mVDC or >4950 mVDC. Either of these conditions will result in an invalid M/R ratio.	GFC Wheel stopped Failed sync/demod board If status LEDs on the sync/demod board <u>ARE</u> flashing the cause is most likely a failed: IR source Relay board I ² C bus IR photo-detector
SYSTEM RESET	The computer has rebooted.	This message occurs at power on. If you have not cycled the power on your instrument: Failed +5 VDC power, Fatal error caused software to restart Loose connector/wiring
WHEEL TEMP WARNING	The filter wheel temperature is controlled at 68 ± 2 °C	Blocked cooling vents below GFC Assembly. Make sure that adequate clear space beneath the analyzer. Analyzer's top cover removed Wheel heater Wheel temperature sensor Relay controlling the wheel heater Entire relay board I ² C bus

11.1.2. FAULT DIAGNOSIS WITH TEST FUNCTIONS

Besides being useful as predictive diagnostic tools, the test functions viewable from the front panel can be used to isolate and identify many operational problems when combined with a thorough understanding of the analyzer's Theory of Operation (see Section 12).

The acceptable ranges for these test functions are listed in the "Nominal Range" column of the analyzer *Final Test and Validation Data Sheet* (GFC7002T, P/N 04307 and GFC7002TU, P/N 04311) shipped with the instrument. Values outside these acceptable ranges indicate a failure of one or more of the analyzer's subsystems. Functions whose values are still within the acceptable range but have significantly changed from the measurement recorded on the factory data sheet may also indicate a failure.

Note

A worksheet has been provided in Appendix C to assist in recording the value of these test functions. This worksheet also includes expected values for the various test functions.

The following table contains some of the more common causes for these values to be out of range.

Table 11-2: Test Functions - Indicated Failures

TEST FUNCTIONS (As Displayed)	INDICATED FAILURE(S)
TIME	Time of day clock is too fast or slow. To adjust, see Section 5.6. Battery in clock chip on CPU board may be dead.
RANGE	Incorrectly configured measurement range(s) could cause response problems with a Data logger or chart recorder attached to one of the analog output. If the Range selected is too small, the recording device will over range. If the Range is too big, the device will show minimal or no apparent change in readings.
STABIL	Indicates noise level of instrument or N ₂ O concentration of sample gas (see Section 11.4.2 for causes).
N2O MEAS & N2O REF	If the value displayed is too high the IR Source has become brighter. Adjust the variable gain potentiometer on the sync/demod board (see Section 11.5.7.1). If the value displayed is too low or constantly changing and the N2O REF is OK: <ul style="list-style-type: none"> • Failed multiplexer on the motherboard • Failed sync/demod board • Loose connector or wiring on sync/demod board • If the value displayed is too low or constantly changing and the N2O REF is bad: • GFC Wheel stopped or rotation is too slow • Failed sync/demod board IR source • Failed IR source • Failed relay board • Failed I²C bus • Failed IR photo-detector
MR Ratio	When the analyzer is sampling zero air and the ratio is too low: <ul style="list-style-type: none"> • The reference cell of the GFC Wheel is contaminated or leaking. • The alignment between the GFC Wheel and the segment sensor, the M/R sensor or both is incorrect. • Failed sync/demod board When the analyzer is sampling zero air and the ratio is too high: <ul style="list-style-type: none"> • Zero air is contaminated • Failed IR photo-detector
PRES	See Table 11-1 for SAMPLE PRES WARN.
SAMPLE FL	Check for gas flow problems (see Section 11.2).
SAMP TEMP	SAMPLE TEMP should be close to BENCH TEMP. Temperatures outside of the specified range or oscillating temperatures are cause for concern.
BENCH TEMP	Bench temp control improves instrument noise, stability and drift. Temperatures outside of the specified range or oscillating temperatures are cause for concern. Table 11-1 for BENCH TEMP WARNING.
WHEEL TEMP	Wheel temp control improves instrument noise, stability and drift. Outside of set point or oscillating temperatures are causes for concern. See Table 11-1 for WHEEL TEMP WARNING.
BOX TEMP	If the box temperature is out of range, check fan in the power supply module. Areas to the side and rear of instrument should allow adequate ventilation. See Table 11-1 for BOX TEMP WARNING.
PHT DRIVE	If this drive voltage is out of range it may indicate one of several problems: <ul style="list-style-type: none"> • A poor mechanical connection between the photodetector, its associated mounting hardware and the absorption cell housing; • An electronic failure of the IR Photo-Detector's built-in cooling circuitry, or; • A temperature problem inside the analyzer chassis. In this case other temperature warnings would also be active such as BENCH TEMP WARNING or BOX TEMP WARNING.

TEST FUNCTIONS (As Displayed)	INDICATED FAILURE(S)
SLOPE	Values outside range indicate Contamination of the zero air or span gas supply Instrument is Miscalibrated Blocked gas flow Contaminated or leaking GFC Wheel (either chamber) Faulty IR photo-detector Faulty sample faulty IR photo-detector pressure sensor (P1) or circuitry Invalid M/R ratio (see above) Bad/incorrect span gas concentration due.
OFFSET	Values outside range indicate Contamination of the zero air supply Contaminated or leaking GFC Wheel (either chamber) Faulty IR photo-detector

11.1.3. THE DIAGNOSTIC SIGNAL I/O FUNCTION

The signal I/O diagnostic mode allows access to the digital and analog I/O in the analyzer. Some of the digital signals can be controlled through the touchscreen. These signals, combined with a thorough understanding of the instruments Theory of Operation (found in Section 12), are useful for troubleshooting in three ways:

- The technician can view the raw, unprocessed signal level of the analyzer’s critical inputs and outputs.
- Many of the components and functions that are normally under algorithmic control of the CPU can be manually exercised.
- The technician can directly control the signal level Analog and Digital Output signals.

This allows the technician to observe systematically the effect of directly controlling these signals on the operation of the analyzer. The following flowchart shows an example of how to use the Signal I/O menu to view the raw voltage of an input signal or to control the state of an output voltage or control signal. (See also Sections 5.8.1 and 11.5.8.1).

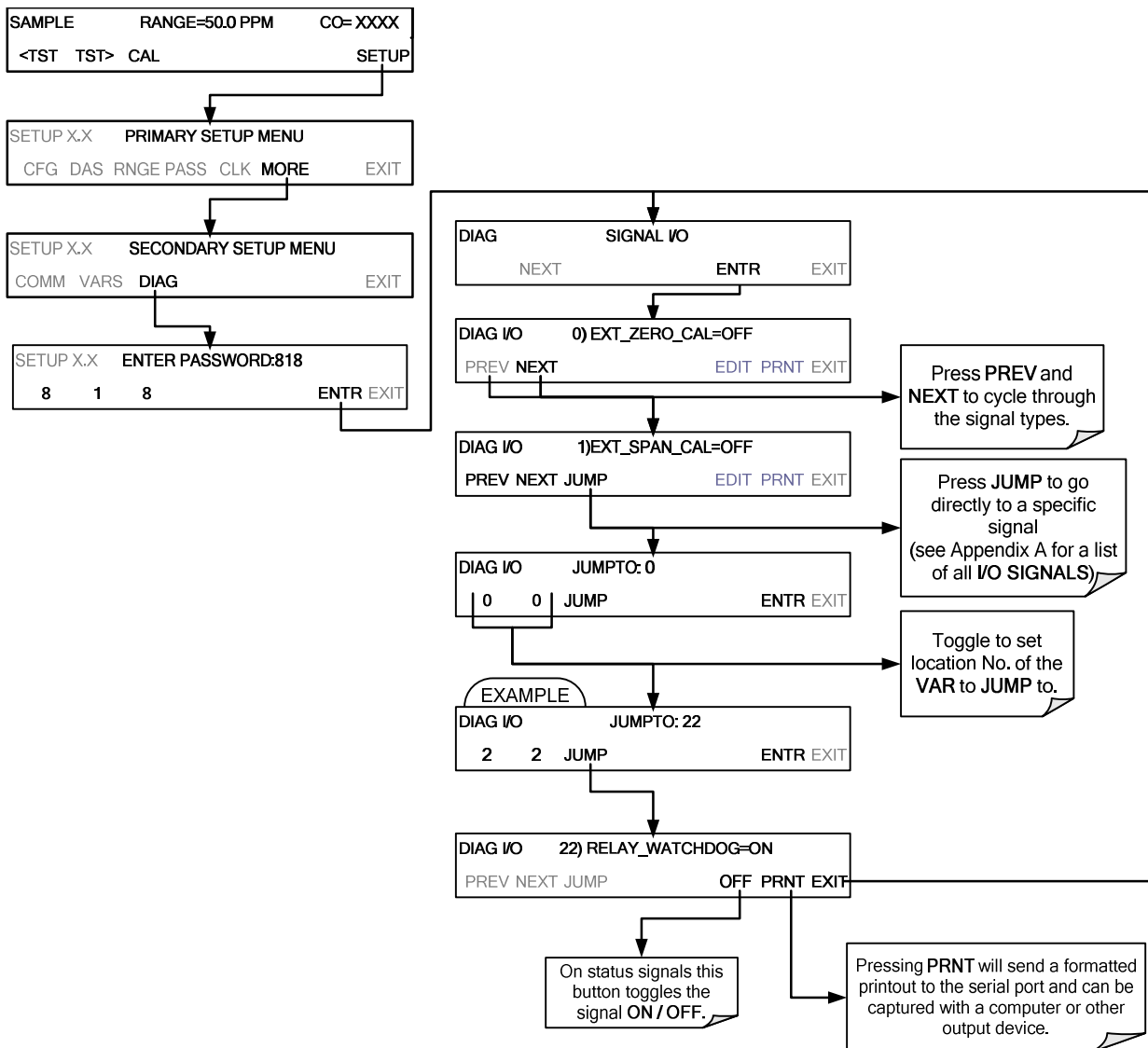

Figure 11-2: Example of Signal I/O Function

Note: The above screen(s) show CO concentration displayed. Your instrument will indicate and display N₂O concentration.

Note

Any I/O signals changed while in the signal I/O menu will remain in effect **ONLY** until signal I/O menu is exited. The Analyzer regains control of these signals upon exit. See Appendix A-4 for a complete list of the parameters available for review under this menu.

11.1.4. STATUS LEDS

Several color-coded light-emitting diodes (LEDs) are located inside the instrument to assist in determining if the analyzer’s CPU, I²C bus and relay board, GFC Wheel and the sync/demodulator board are functioning properly.

11.1.4.1. MOTHERBOARD STATUS INDICATOR (WATCHDOG)

DS5, a red LED, that is located on upper portion of the motherboard, just to the right of the CPU board, flashes when the CPU is running the main program loop. After power-up, approximately 30 to 60 seconds, DS5 should flash on and off. If characters are written to the front panel display but DS5 does not flash then the program files have become corrupted. If after 30 – 60 seconds neither the DS5 is flashing or no characters have been written to the front panel display then the CPU is bad and must be replaced.

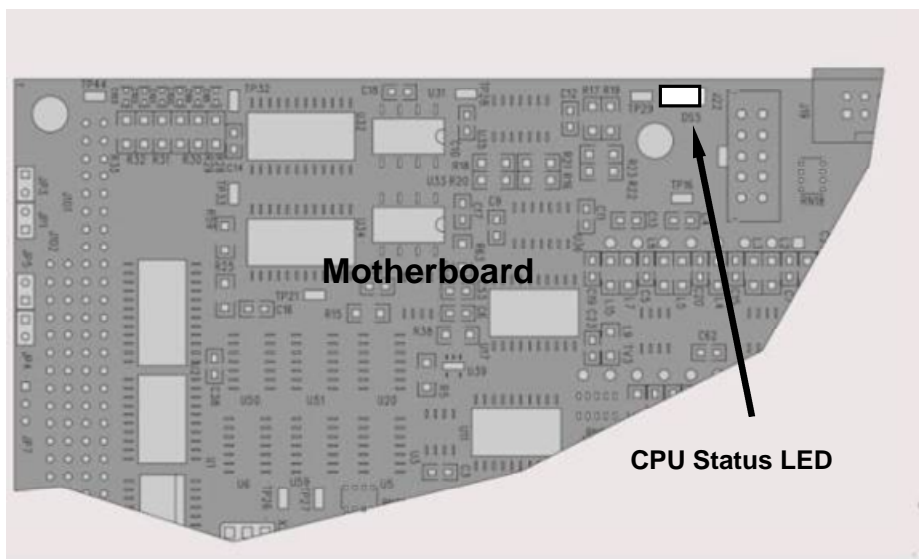

Figure 11-3: CPU Status Indicator

11.1.4.2. SYNC DEMODULATOR STATUS LEDS

Two LEDs located on the Sync/Demod Board and are there to make it obvious that the GFC Wheel is spinning and the synchronization signals are present:

Table 11-3: Sync/Demod Board Status Failure Indications

LED	FUNCTION	FAULT STATUS	INDICATED FAILURE(S)
D1	M/R Sensor Status (Flashes slowly)	LED is stuck ON or OFF	GFC Wheel is not turning M/R Sensor on Opto-Pickup Board failed Sync/Demod Board failed JP 4 Connector/Wiring faulty Failed/Faulty +5 VDC Power Supply (PS1)
D2	Segment Sensor Status (Flashes quickly)	LED is stuck ON or OFF	GFC Wheel is not turning Segment Sensor on Opto-Pickup Board failed Sync/Demod Board failed JP 4 Connector/Wiring faulty Failed/Faulty +5 VDC Power Supply (PS1)

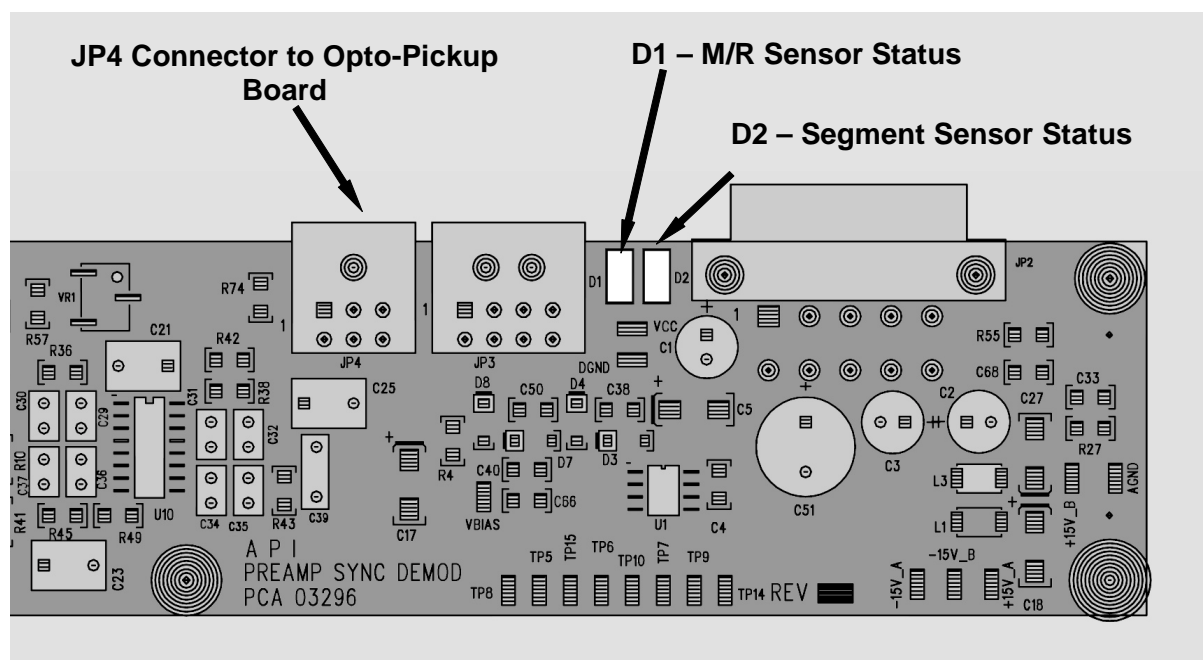

Figure 11-4: Sync/Demod Board Status LED Locations

11.1.4.3. RELAY BOARD STATUS LEDS

There are eight LEDs located on the Relay Board. The most important of which is D1, which indicates the health of the I²C bus. If D1 is blinking the other faults following LEDs can be used in conjunction with **DIAG** menu signal I/O to identify hardware failures of the relays and switches on the relay (see Section 11.1.3 and Appendix D).

Table 11-4: I²C Status LED Failure Indications

LED	FUNCTION	FAULT STATUS	INDICATED FAILURE(S)
D1 (Red)	I ² C bus Health (Watch Dog Circuit)	Continuously ON or Continuously OFF	Failed/Halted CPU Faulty Motherboard, Touchscreen or Relay Board Faulty Connectors/Wiring between Motherboard, Touchscreen or Relay Board Failed/Faulty +5 VDC Power Supply (PS1)

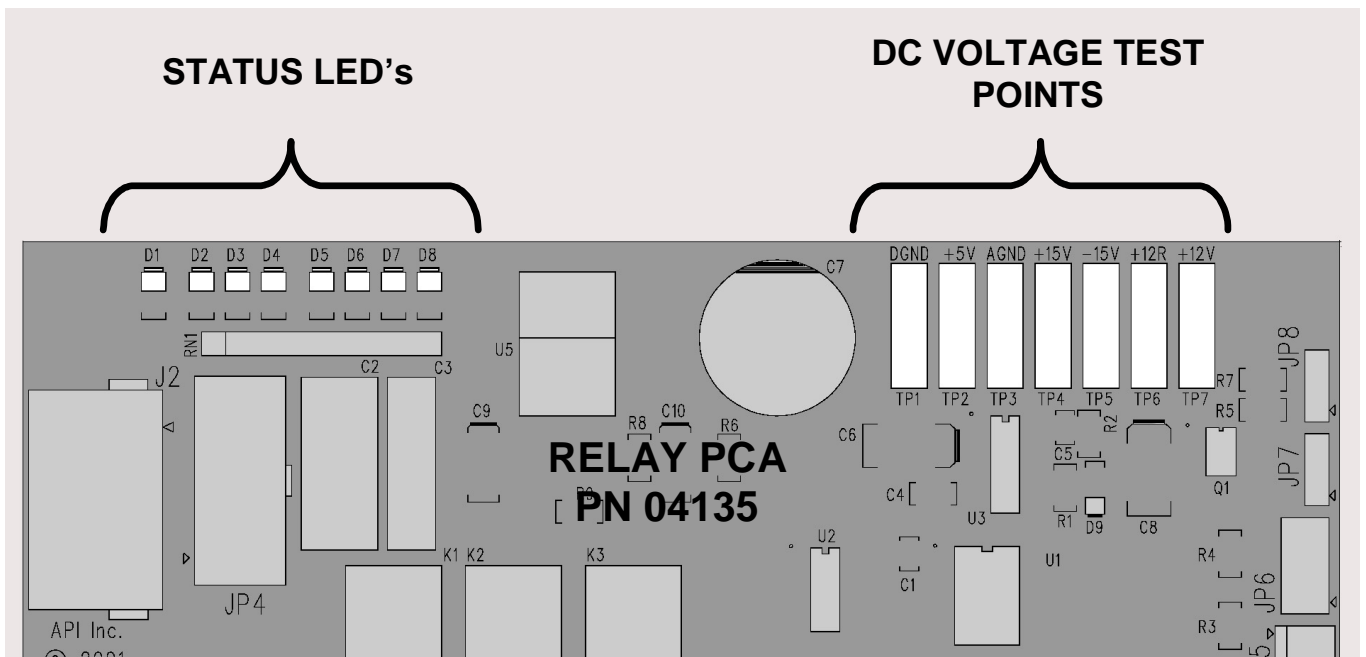

Figure 11-5: Relay Board Status LEDs

Table 11-5: Relay Board Status LED Failure Indications

LED	FUNCTION	SIGNAL I/O PARAMETER		DIAGNOSTIC TECHNIQUE
		ACTIVATED BY	VIEW RESULT	
D2 Yellow	Wheel Heater	WHEEL_HEATER	WHEEL_TEMP	Voltage displayed should change. If not: Failed Heater Faulty Temperature Sensor Failed AC Relay Faulty Connectors/Wiring
D3 Yellow	Bench Heater	BENCH_HEATER	BENCH_TEMP	Voltage displayed should change. If not: Failed Heater Faulty Temperature Sensor Failed AC Relay Faulty Connectors/Wiring
D4 Yellow	Spare	N/A	N/A	N/A
D5 Green	Sample/Cal Gas Valve Option	CAL_VALVE	N/A	Sample/Cal Valve should audibly change states. If not: Failed Valve Failed Relay Drive IC on Relay Board Failed Relay Board Faulty +12 VDC Supply (PS2) Faulty Connectors/Wiring
D6 Green	Zero/Span Gas Valve Option	SPAN_VALVE	N/A	Zero/Span Valve should audibly change states. If not: Failed Valve Failed Relay Drive IC on Relay Board Failed Relay Board Faulty +12 VDC Supply (PS2) Faulty Connectors/Wiring
D7 Green	Shutoff Valve Option	SHUTOFF_VALVE	N/A	Shutoff Valve should audibly change states. If not: Failed Valve Failed Relay Drive IC on Relay Board Failed Relay Board Faulty +12 VDC Supply (PS2) Faulty Connectors/Wiring
D8 Green	IR SOURCE	IR_SOURCE	CO_MEASURE	Voltage displayed should change. If not: Failed IR Source Faulty +12 VDC Supply (PS2) Failed Relay Board Failed IR Photo-Detector Failed Sync/Demod Board Faulty Connectors/Wiring

11.2. GAS FLOW PROBLEMS

When troubleshooting flow problems, it is a good idea to first confirm that the actual flow and not the analyzer's flow sensor and software are in error, or the flow meter is in error. Use an independent flow meter to perform a flow check as described in Section 10.3.3. If this test shows the flow to be correct, check the pressure sensors as described in Section 11.5.7.6.

The GFC7002T/GFC7002TU has one main gas flow path. With the IZS or zero/span valve option installed, there are several subsidiary paths but none of those are displayed on the front panel or stored by the DAS.

With the O₂ sensor option installed, third gas flow controlled with a critical flow orifice is added, but this flow is not measured or reported.

In general, flow problems can be divided into three categories:

1. Flow is too high
2. Flow is greater than zero, but is too low, and/or unstable
3. Flow is zero (no flow)

When troubleshooting flow problems, it is crucial to confirm the actual flow rate without relying on the analyzer's flow display. The use of an independent, external flow meter to perform a flow check as described in Section 10.3.3 is essential.

The flow diagrams found in a variety of locations within this manual depicting the GFC7002T/GFC7002TU in its standard configuration and with options installed can help in trouble-shooting flow problems. For your convenience they are collected here.

11.2.1. GFC7002T/GFC7002TU INTERNAL GAS FLOW DIAGRAMS

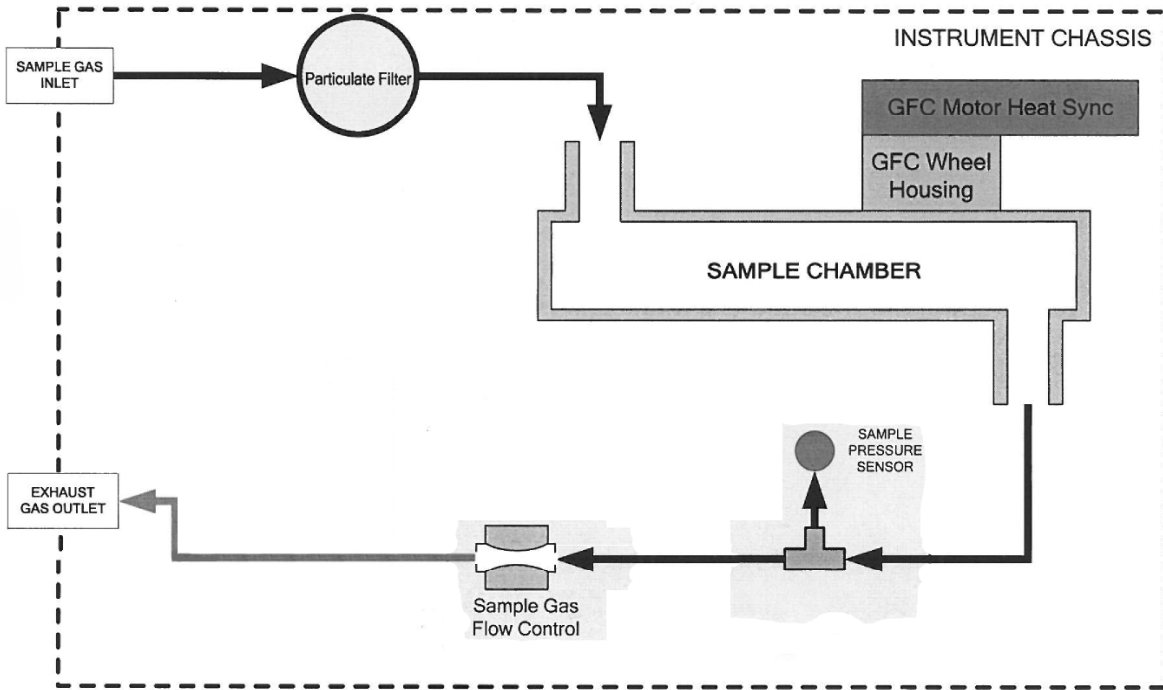

Figure 11-6: GFC7002T/GFC7002TU – Basic Internal Gas Flow

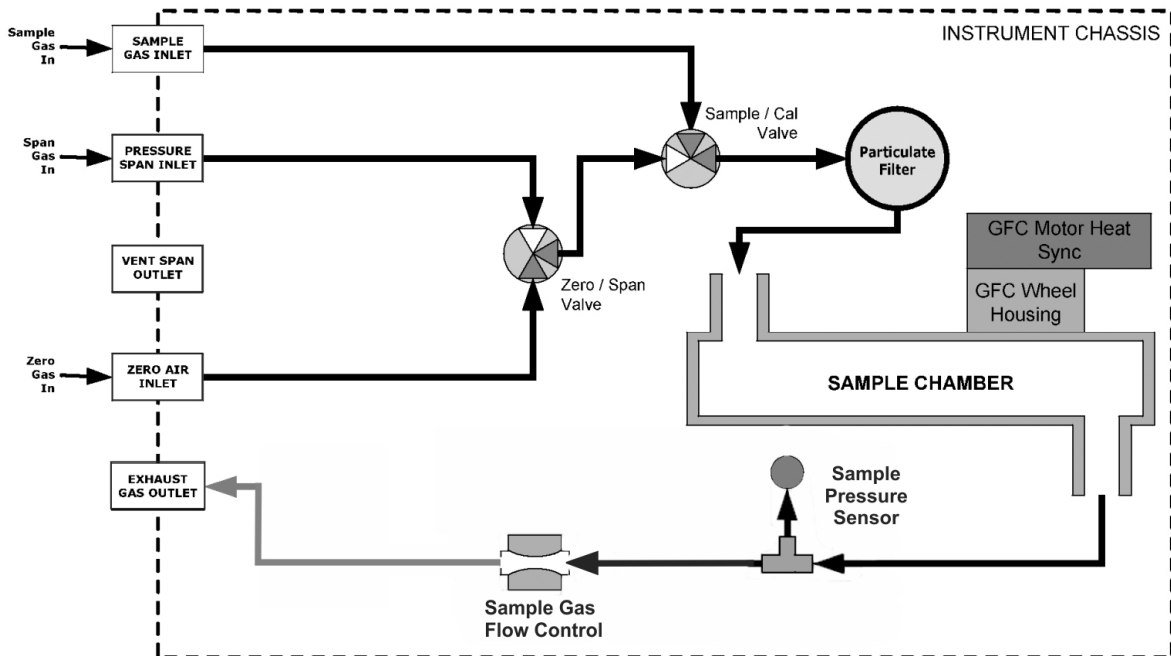

Figure 11-7: Internal Pneumatic Flow OPT 50A – Zero/Span Valves (OPT 50A & 50B)

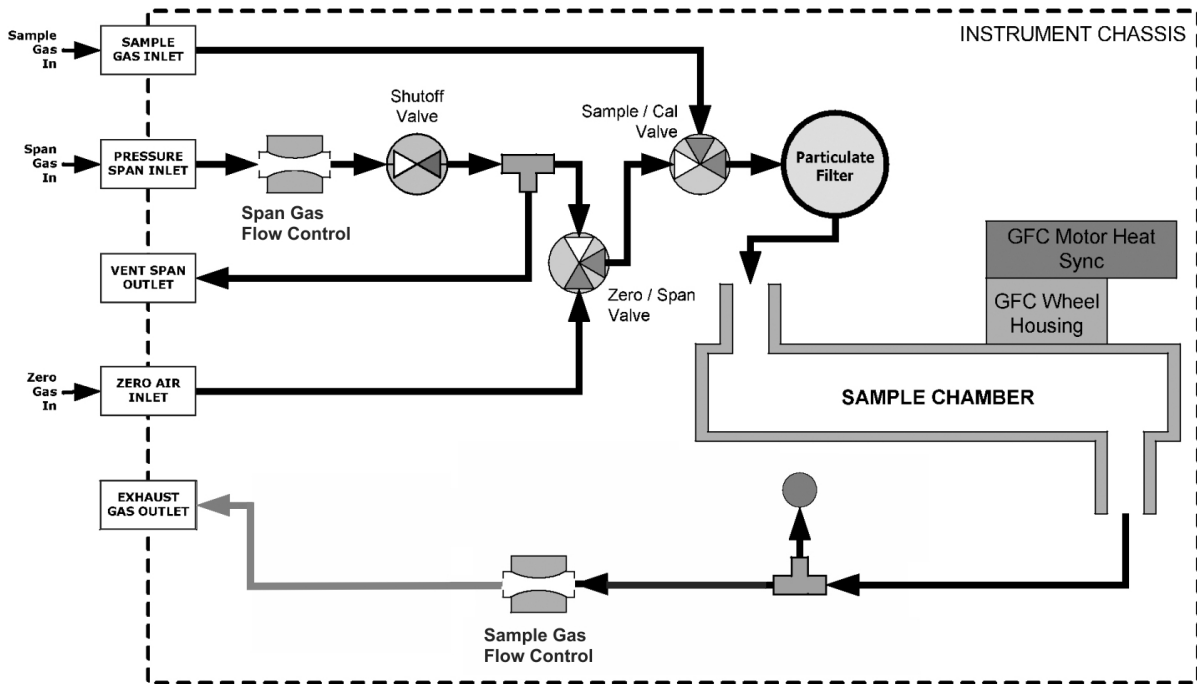

Figure 11-8: Internal Pneumatic Flow OPT 50B – Zero/Span/Shutoff Valves

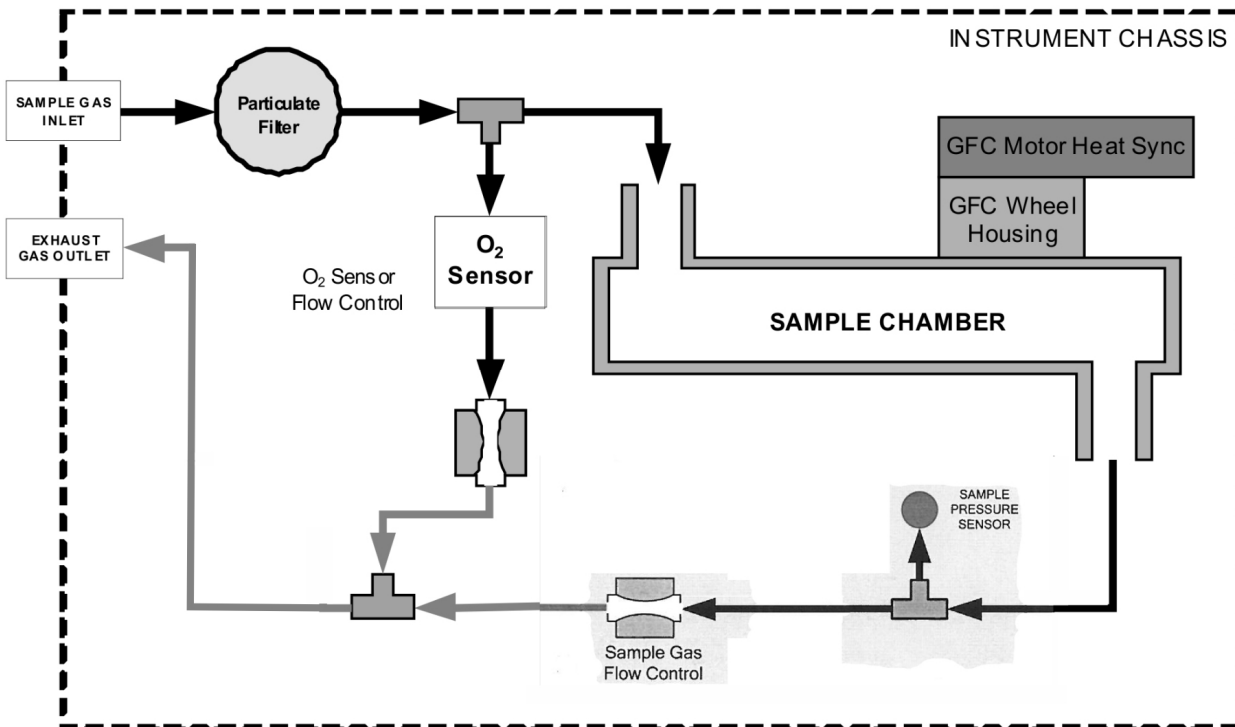

Figure 11-9: GFC7002T/GFC7002TU – Internal Pneumatics with O₂ Sensor Option 65A

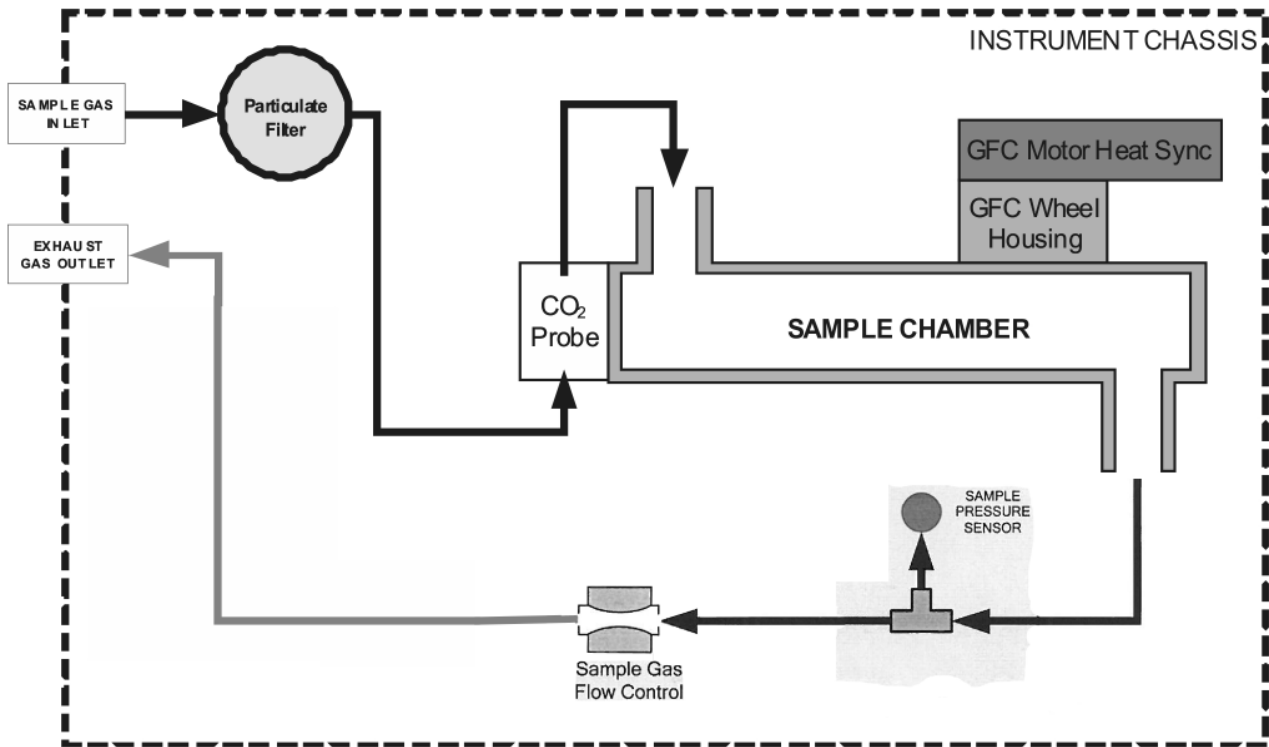

Figure 11-10: GFC7002T/GFC7002TU – Internal Pneumatics with CO₂ Sensor Option 67A

11.2.2. TYPICAL SAMPLE GAS FLOW PROBLEMS

11.2.2.1. FLOW IS ZERO

The unit displays a **SAMPLE FLOW** warning message on the front panel display or the **SAMPLE FLOW** test function reports a zero or very low flow rate.

Confirm that the sample gas is connected correctly and is free to flow.

- Make sure that the unit is in basic **SAMPLE** Mode.
- Place a finger over an Exhaust outlet on the rear panel of the instrument.
- If gas is flowing through the analyzer, you will feel flow from the Exhaust outlet.
- Gas bottles are not empty or low.
- Valves, regulators and gas lines are not clogged or dirty.

11.2.2.2. LOW FLOW

1. Check for leaks as described in Section 10.3.2. Repair the leaking fitting, line or valve and re-check.
2. Check for the sample filter and the orifice filter for dirt. Replace filters (see 10.3.1).
3. Check for partially plugged pneumatic lines, or valves. Clean or replace them.
4. Check for plugged or dirty critical flow orifices. Replace them.

5. If an IZS option is installed in the instrument, press CALZ and CALS. If the flow increases then suspect a bad sample/cal valve.

11.2.2.3. HIGH FLOW

The most common cause of high flow is a leak in the sample flow control assembly. If no leaks or loose connections are found in the fittings or the gas line at the orifice, replace the critical flow orifice(s) inside the sample flow control assembly.

11.2.2.4. DISPLAYED FLOW = “WARNINGS”

This warning means that there is inadequate gas flow. There are four conditions that might cause this:

1. A leak upstream or downstream of the flow sensor
2. A flow obstruction upstream or downstream of the flow sensor
3. Bad Flow Sensor Board

To determine which case is causing the flow problem, view the sample pressure and sample flow functions on the front panel. If the sample pressure is reading abnormally low, then the cause is likely a flow obstruction upstream of the flow sensor. First, check the sample filter and make sure it is not plugged and then systematically check all the other components upstream of the orifice to ensure that they are not obstructed.

If the sample pressure is reading normal but the sample flow is reading low then it is likely that there is an obstruction downstream of the flow sensor.

11.2.2.5. ACTUAL FLOW DOES NOT MATCH DISPLAYED FLOW

If the actual flow measured does not match the displayed flow, but is within the limits of 720-880 cm³/min, adjust the calibration of the flow measurement as described in Section 10.3.3.

11.3. CALIBRATION PROBLEMS

11.3.1. MISCALIBRATED

There are several symptoms that can be caused by the analyzer being miscalibrated. This condition is indicated by out of range Slopes and Offsets as displayed through the test functions and is frequently caused by the following:

1. Bad span gas. This can cause a large error in the slope and a small error in the offset. Delivered from the factory, the GFC7002T Analyzer's slope is within $\pm 15\%$ of nominal. Bad span gas will cause the analyzer to be calibrated to the wrong value. If in doubt have the span gas checked by an independent lab.
2. Contaminated zero gas. Excess H₂O can cause a positive or negative offset and will indirectly affect the slope.
3. Dilution calibrator not set up correctly or is malfunctioning. This will also cause the slope, but not the zero, to be incorrect. Again the analyzer is being calibrated to the wrong value.
4. Too many analyzers on the manifold. This can cause either a slope or offset error because ambient gas with its pollutants will dilute the zero or span gas.

11.3.2. NON-REPEATABLE ZERO AND SPAN

As stated earlier, leaks both in the GFC7002T/GFC7002TU and in the external system are a common source of unstable and non-repeatable readings.

1. Check for leaks in the pneumatic systems as described in Section 10.3.2. Don't forget to consider pneumatic components in the gas delivery system outside the GFC7002T/GFC7002TU such as:
 - A change in zero air source such as ambient air leaking into zero air line, or;
 - A change in the span gas concentration due to zero air or ambient air leaking into the span gas line.
2. Once the instrument passes a leak check, perform a flow check (see Section 10.3.3) to make sure adequate sample is being delivered to the sensor assembly.
3. A failing IR photo-detector may be at fault. Check the **N₂O MEAS** and **N₂O REF** test functions via the front panel display to make sure the signal levels are in the normal range (See Appendix A) and are quiet.
4. Confirm the sample pressure, wheel temperature, bench temperature, and sample flow readings are correct and have steady readings.
5. Disconnect the exhaust line from the optical bench near the rear of the instrument and plug this line into the SAMPLE inlet creating a pneumatic loop. The N₂O concentration (either zero or span) now must be constant. If readings become quiet, the problem is in the external pneumatics supplies for sample gas, span gas or zero air.
6. If pressurized span gas is being used with a zero/span valve option, make sure that the venting is adequate.

11.3.3. INABILITY TO SPAN – NO SPAN BUTTON (CAL5)

1. Confirm that the carbon monoxide span gas source is accurate; this can be done by switching between two span-gas tanks. If the N₂O concentration is different, there is a problem with one of the tanks.
2. Check for leaks in the pneumatic systems as described in Section 10.3.2.
3. Make sure that the expected span gas concentration entered into the instrument during calibration is the correct span gas concentration and not too different from expected span value. This can be viewed via the CONC submenu of the Sample Displays.
4. Check to make sure that there is no ambient air or zero air leaking into span gas line.

11.3.4. INABILITY TO ZERO – NO ZERO BUTTON (CALZ)

1. Confirm that there is a good source of zero air. Dilute a tank of span gas with the same amount of zero air from two different sources. If the N₂O concentration of the two measurements is different, there is a problem with one of the sources of zero air.
2. Check for leaks in the pneumatic systems as described in 10.3.2.
3. Check to make sure that there is no ambient air leaking into zero air line.

11.4. OTHER PERFORMANCE PROBLEMS

Dynamic problems (i.e. problems which only manifest themselves when the analyzer is monitoring sample gas) can be the most difficult and time consuming to isolate and

resolve. The following provides an itemized list of the most common dynamic problems with recommended troubleshooting checks and corrective actions.

11.4.1. TEMPERATURE PROBLEMS

Individual control loops are used to maintain the set point of the absorption bench, filter wheel and IR photo-detector temperatures. If any of these temperatures are out of range or are poorly controlled, the GFC7002T/GFC7002TU will perform poorly.

11.4.1.1. BOX OR SAMPLE TEMPERATURE

BOX TEMPERATURE

The box temperature sensor is mounted to the motherboard and cannot be disconnected to check its resistance. Rather check the **BOX TEMP** signal using the SIGNAL I/O function under the **DIAG** Menu (See Section 5.8.1). This parameter will vary with ambient temperature, but at $\sim 30^{\circ}\text{C}$ (6-7° above room temperature) the signal should be ~ 1450 mV.

SAMPLE TEMPERATURE

The Sample Temperature should closely track the bench temperature. If it does not, locate the sensor, which is located at the midpoint of the optical bench in a brass fitting. Unplug the connector labeled “Sample”, and measure the resistance of the thermistor; at room temperature (25°C) it should be $\sim 30\text{K}$ Ohms, at operating temperature, 48°C , it should be $\sim 12\text{K}$ Ohms

11.4.1.2. BENCH TEMPERATURE

There are three possible failures that could cause the Bench temperature to be incorrect.

1. The heater mounted to the bottom of the Absorption bench is electrically shorted or open.
 - Check the resistance of the two heater elements by measuring between pin 2 and 4 (~ 76 Ohms), and pin 3 and 4 (~ 330 Ohms), of the white five-pin connector just below the sample temperature sensor on the Bench (pin 1 is the pointed end).
2. Assuming that the I²C bus is working and that there is no other failure with the relay board, the solid-state relay (K2) on the relay board may have failed.
 - Using the BENCH_HEATER parameter under the signal I/O function, as described above, turn on and off K2 (D3 on the relay board should illuminate as the heater is turned on).
 - Check the AC voltage present between pin 2 and 4, for a 100 or 115 VAC model, and pins 3 and 4, for a 220-240 VAC model.



WARNING - ELECTRICAL SHOCK HAZARD
Hazardous Voltages are present during this test.

3. If the relay has failed there should be no change in the voltage across pins 2 and 4 or 3 and 4. Note: K2 is in a socket for easy replacement.

4. If K2 checks out OK, the thermistor temperature sensor located on the optical bench near the front of the instrument could be at fault.
 - Unplug the connector labeled “Bench”, and measure the resistance of the thermistor.
 - At room temperature it should have approximately 30K Ohms resistance; near the 48°C set point it should have ~12K ohms.

11.4.1.3. GFC WHEEL TEMPERATURE

Like the bench heater above there are three possible causes for the GFC Wheel temperature to have failed.

1. The wheel heater has failed.
 - Check the resistance between pins 1 and 4 on the white five-pin connector just below the sample temperature sensor on the bench (pin 1 is the pointed end).
 - It should be approximately 275 ohms.
2. Assuming that the I²C bus is working and that there is no other failure with the relay board; the solid-state relay (K1) on the relay board may have failed.
 - Using the **WHEEL_HEATER** parameter under the signal I/O function, as described above, turn on and off K1 (D2 on the relay board should illuminate as the heater is turned on).
 - Check the AC voltage present between pin 1 and 4.



WARNING - ELECTRICAL SHOCK HAZARD
Hazardous Voltages are present during this test.

3. If the relay has failed there should be no change in the voltage across pins 1 and 4.
 - K1 is socketed for easy replacement.
4. If K1 checks out OK, the thermistor temperature sensor located at the front of the filter wheel assembly may have failed.
5. Unplug the connector labeled “Wheel”, and measure the resistance of the thermistor. The resistance near the 68°C set point is ~5.7k ohms.

11.4.1.4. IR PHOTO-DETECTOR TEC TEMPERATURE

If the PHT DRIVE test parameter described in Table 10-3 is out of range there are four possible causes of failure.

1. The screws retaining the IR photo detector to the absorption bench have become loose.
 - Carefully tighten the screws, hand-tight and note whether, after the analyzer has come up to operating temperature, whether the **PHT DRIVE** voltage has returned to an acceptable level.
2. The two large transistor-type devices mounted to the side of the Absorption Bench have come loose from the bench.
 - Tighten the retaining screws and note whether there is an improvement in the **PHT DRIVE** voltage.

3. The photo-detector has failed. Contact the factory for instructions.
4. The sync demodulator circuit board has failed. Contact the factor for instructions.

11.4.2. EXCESSIVE NOISE

Noise is continuously monitored in the **TEST** functions as the **STABIL** reading and only becomes meaningful after sampling a constant gas concentration for at least 10 minutes. Compare the current **STABIL** reading with that recorded at the time of manufacture (included in the GFC7002T/GFC7002TU *Final Test and Validation Data Sheet*, P/N 04271 shipped with the unit from TAD).

1. The most common cause of excessive noise is leaks. Leak check and flow check the instrument described in Section 10.3.2 and 10.3.3.
2. Detector failure – caused by failure of the hermetic seal or over-temperature due to poor heat sinking of the detector can to the optical bench.
 - In addition to increased noise due to poor signal-to-noise ratio, another indicator of detector failure is a drop in the signal levels of the **N2O MEASURE** signal and **N2O REFERENCE** signal.
3. Sync/Demod Board failure. There are many delicate, high impedance parts on this board. Check the **N2O MEAS** and **N2O REF** Test Functions via the Front Panel Display.
4. The detector cooler control circuit can fail for reasons similar to the detector itself failing. Symptoms would be a change in **MR RATIO** Test Function when zero air is being sampled.
5. Also check the SIGNAL I/O parameter **PHT DRIVE**.
 - After warm-up, and at 25°C ambient, if **PHT DRIVE** < 4800 mV, the cooler is working properly.
 - If **PHT DRIVE** is > 4800 mV there is a malfunction.
 - The +5 and ±15 VDC voltages in the GFC7002T/GFC7002TU are provided by switching power supplies.
 - Switch mode supplies create DC outputs by switching the input AC waveform at high frequencies.
 - As the components in the switcher age and degrade, the main problem observed is increased noise on the DC outputs.
 - If a noisy switcher power supply is suspected, attach an oscilloscope to the DC output test points located on the top right hand edge of the Relay board.
 - Look for short period spikes > 100 mV p-p on the DC output

11.5. SUBSYSTEM CHECKOUT

The preceding subsections discussed a variety of methods for identifying possible sources of failures or performance problems within the analyzer. In most cases this included a list of possible causes. If the problem is not resolved at this point, the next step is to check the subsystems. This subsection describes how to determine whether an individual component or subsystem is the cause of the problem being investigated.

11.5.1. AC MAINS CONFIGURATION

The analyzer is correctly configured for the AC mains voltage in use if:

- The GFC Wheel motor is spinning. LEDs D1 & D2 (located on the sync/demod PCA) should be flashing.
- If incorrect power is suspected, check that the correct voltage and frequency is present at the line input on the rear panel.

Note

-
- **If the unit is set for 230 VAC and is plugged into 115VAC, or 100VAC the sample pump (if equipped) will not start, and the heaters will not come up to temperature.**
 - **If the unit is set for 115 or 100 VAC and is plugged into a 230 VAC circuit, the circuit breaker built into the ON/OFF Switch on the Front Panel will trip to the OFF position immediately after power is switched on.**
-

11.5.2. DC POWER SUPPLY

If you have determined that the analyzer’s AC mains power is working, but the unit is still not operating properly, there may be a problem with one of the instrument’s switching power supplies. The supplies can have two faults, namely no DC output, and noisy output.

To assist tracing DC Power Supply problems, the wiring used to connect the various printed circuit assemblies and DC Powered components and the associated test points on the relay board follow a standard color-coding scheme as defined in the following table.

Table 11-6: DC Power Test Point and Wiring Color Codes

NAME	TEST POINT#	TP AND WIRE COLOR
Dgnd	1	Black
+5V	2	Red
Agnd	3	Green
+15V	4	Blue
-15V	5	Yellow
+12R	6	Purple
+12V	7	Orange

A voltmeter should be used to verify that the DC voltages are correct per the values in the table below, and an oscilloscope, in AC mode, with band limiting turned on, can be used to evaluate if the supplies are producing excessive noise (> 100 mV p-p).

Table 11-7: DC Power Supply Acceptable Levels

POWER SUPPLY ASSY	VOLTAGE	CHECK RELAY BOARD TEST POINTS				MIN V	MAX V
		FROM TEST POINT		TO TEST POINT			
		NAME	#	NAME	#		
PS1	+5	Dgnd	1	+5	2	4.8	5.25
PS1	+15	Agnd	3	+15	4	13.5	16V

PS1	-15	Agnd	3	-15V	5	-14V	-16V
PS1	Agnd	Agnd	3	Dgnd	1	-0.05	0.05
PS1	Chassis	Dgnd	1	Chassis	N/A	-0.05	0.05
PS2	+12	+12V Ret	6	+12V	7	11.75	12.5
PS2	Dgnd	+12V Ret	6	Dgnd	1	-0.05	0.05

11.5.3. I²C BUS

Operation of the I²C bus can be verified by observing the behavior of D1 on the relay PCA. Assuming that the DC power supplies are operating properly, the I²C bus is operating properly if D1 on the relay PCA is flashing.

11.5.4. TOUCHSCREEN INTERFACE

Verify the functioning of the touchscreen by observing the display when pressing a touchscreen control button. Assuming that there are no wiring problems and that the DC power supplies are operating properly, if pressing a control button on the display does not change the display, any of the following may be the problem:

- The touchscreen controller may be malfunctioning.
- The internal USB bus may be malfunctioning.

You can verify this failure by logging on to the instrument using APICOM or a terminal program to any of the communications ports. If the analyzer responds to remote commands and the display changes accordingly, the touchscreen interface may be faulty.

11.5.5. LCD DISPLAY MODULE

Verify the functioning of the front panel display by observing it when power is applied to the instrument. Assuming that there are no wiring problems and that the DC power supplies are operating properly, the display screen should light and show the splash screen with logo and other indications of its state as the CPU goes through its initialization process.

11.5.6. RELAY BOARD

The relay board PCA (P/N 04135) can be most easily checked by observing the condition of the its status LEDs on the relay board, as described in Section 11.1.4.3, and the associated output when toggled on and off through signal I/O function in the diagnostic menu, see Section 11.1.3.

1. If the front panel display responds to button presses and D1 on the relay board is NOT flashing then either the wiring between the touchscreen and the relay board is bad, or the relay board is bad.
2. If D1 on the relay board is flashing and the status indicator for the output in question (heater power, valve drive, etc.) toggles properly using the signal I/O function, then the associated control device on the relay board is bad.
 - Several of the control devices are in sockets and can be easily replaced.
 - The table below lists the control device associated with a particular function:

Table 11-8: Relay Board Control Devices

FUNCTION	CONTROL DEVICE	IN SOCKET
Wheel Heater	K1	Yes
Bench Heater	K2	Yes
Spare AC Control	K3	Yes
IZS Valves	U4	Yes
IR Source Drive	U5	No

The IR source drive output can be verified by measuring the voltage at J16 with the IR source disconnected. It should be 11.5± 0.5 VDC.

11.5.7. SENSOR ASSEMBLY

11.5.7.1. SYNC/DEMODULATOR ASSEMBLY

To verify that the Sync/Demodulator Assembly is working, follow the procedure below:

1. Verify that D1 and D2 are flashing.
 - If not, check the opto pickup assembly, Section 11.5.7.3 and the GFC Wheel drive, Section 11.5.7.4.
 - If the wheel drive and opto pickup are working properly then verify that there is 2.4 ±0.1 VAC and 2.5 ±0.15 VDC between digital ground and TP 5 on the sync/demod board. If not then check the wiring between the sync/demod and opto pickup assembly (see interconnect drawing, P/N 04216). If good then the sync/demod board is bad.
2. Verify that the IR source is operating, Section 11.5.7.5.
3. With the analyzer connected to zero air, measure between TP11 (measure) and analog ground, and TP12 (reference) and analog ground.
 - If they are similar to values recorded on the factory data sheet then there is likely a problem with the wiring or the A/D converter.
 - If they are not then either the sync demodulator board or the IR-photodetector are bad. See Section 11.4.1.4 for problems with the IR-photodetector TEC drive.

11.5.7.2. ELECTRICAL TEST

The electric test function substitutes simulated signals for N2O MEAS and N2O REF, generated by circuitry on the sync/demod board, for the output of the IR photo-detector. While in this mode the user can also view the same test functions viewable from the main **SAMPLE** display. When the test is running, the concentration reported on the front panel display should be 40.0 ppm. Also see Section 5.8.4.

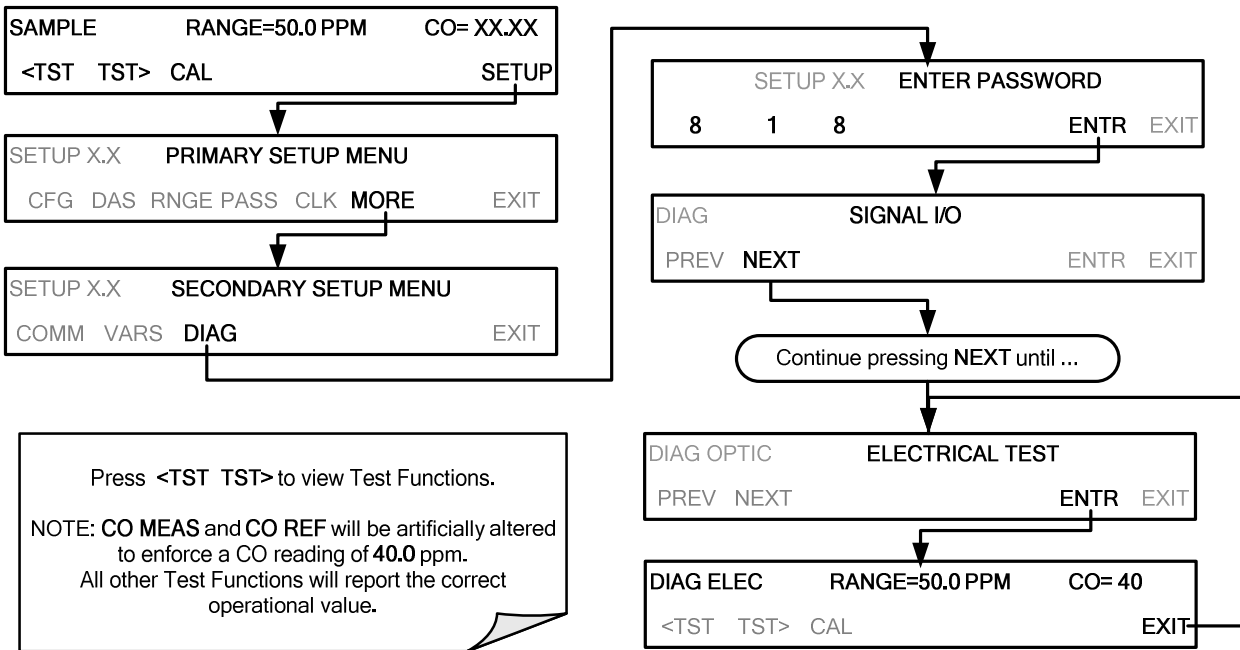

Note: The above screen(s) show CO concentration displayed. Your instrument will indicate and display N₂O concentration.

11.5.7.3. OPTO PICKUP ASSEMBLY

Operation of the opto pickup PCA (P/N 04088) can be verified with a voltmeter. Measure the AC and DC voltage between digital ground on the relay board, or touchscreen and TP2 and TP4 on the sync pickup PCA. For a working board, with the GFC motor spinning, they should read 2.4 ±0.1 VAC and 2.5 ±0.15 VDC.

Further confirmation that the pickups and motor are operating properly can be obtained by measuring the frequency at TP2 and TP4 using a frequency counter, a digital voltmeter with a frequency counter, or an oscilloscope, per Table 11-9.

Table 11-9: Opto Pickup Board Nominal Output Frequencies

AC Mains Freq.	Nominal Measured Frequency	
	TP2	TP4
50 Hz	25	300
60 Hz	30	360

11.5.7.4. GFC WHEEL DRIVE

If the D1 and D2 on the sync demodulator board are not flashing then:

1. Check for power to the motor by measuring between pins 1 and 3 on the connector feeding the motor.
 - For instruments configured for 120 or 220-240VAC there should be approximately 88 VAC for instruments configured for 100VAC, it should be the voltage of the AC mains, approximately 100VAC.
2. Verify that the frequency select jumper, JP4, is properly set on the relay board.
 - For 50 Hz operation it should be installed.
 - For 60 Hz operation may either be missing or installed in a vertical orientation.

3. If there is power to the motor and the frequency select jumper is properly set then the motor is likely bad.
 - See Section 11.6.2 for instructions on removing and replacing the GFC assembly that the motor is bolted to.

11.5.7.5. IR SOURCE

The IR source can be checked using the following procedure:

1. Disconnect the source and check its resistance when cold.
 - When new, the source should have a cold resistance of more than 1.5 Ohms but less than 3.5 Ohms.
 - If not, then the source is bad.
2. With the source disconnected, energize the analyzer and wait for it to start operating.
 - Measure the drive Voltage between pins 1 and 2 on the jack that the source is normally connected to; it should be 11.5 ± 0.25 VDC.
 - If not, then the problem is with the wiring, the relay board, or the +12V power supply.
3. If the drive voltage is correct in step 2, then remove the source from the heat sink assembly (2 screws on top) and connect to its mating connector.
 - Observe the light being emitted from the source.
 - It should be centered at the bottom of the U-shaped element.
 - If there is either no emission or a badly centered emission, then the source is bad.

11.5.7.6. PRESSURE/FLOW SENSOR ASSEMBLY

The pressure/flow sensor PCA, located on the top of the absorption bench, can be checked with a voltmeter using the following procedure which, assumes that the wiring is intact, and that the motherboard and the power supplies are operating properly:

1. For pressure related problems:
 - Measure the voltage across C1 - it should be 5 ± 0.25 VDC.

If not, then the board is bad.

- Measure the voltage across TP4 and TP1.
- It should be $4500 \text{ mV} \pm 250 \text{ mV}$.
- If an internal pump (option) is installed, with the pump energized, it should be approximately 200 mV less.

If the voltage is incorrect, then S1, the pressure transducer is bad, the board is bad, or there is a pneumatic failure preventing the pressure transducer from sensing the absorption cell pressure properly.

2. For flow related problems:
 - Measure the voltage across TP2 and TP1 - it should be 10 ± 0.25 VDC.

If not, then the board is bad.

- Measure the voltage across TP3 and TP1:

- With proper flow (800 sccm at the sample inlet) this should be approximately 4.5V (this voltage will vary with altitude).
- With flow stopped (sample inlet blocked) the voltage should be approximately 1V.

If the voltage is incorrect, the flow sensor is bad, the board is bad, or there is a leak upstream of the sensor.

11.5.8. MOTHERBOARD

11.5.8.1. A/D FUNCTIONS

The simplest method to check the operation of the A-to-D converter on the motherboard is to use the Signal I/O function under the **DIAG** menu to check the two A/D reference voltages and input signals that can be easily measured with a voltmeter.

1. Use the Signal I/O function (see Section 11.1.3 and Appendix A) to view the value of REF_4096_MV and REF_GND.
 - If both are within 3 mV of nominal (4096 and 0), and are stable, ± 0.5 mV then the basic A/D is functioning properly. If not then the motherboard is bad.
2. Choose a parameter in the Signal I/O function such as SAMPLE_PRESSURE, SAMPLE_FLOW, N2O_MEASURE or N2O_REFERENCE.
 - Compare these voltages at their origin (see interconnect drawing and interconnect list) with the voltage displayed through the signal I/O function.
 - If the wiring is intact but there is a large difference between the measured and displayed voltage (± 10 mV) then the motherboard is bad.

See also Sections 5.8.1 and 11.1.3.

11.5.8.2. TEST CHANNEL / ANALOG OUTPUTS VOLTAGE

The **ANALOG OUTPUT** submenu, located under the **SETUP → MORE → DIAG** menu is used to verify that the GFC7002T/GFC7002TU Analyzer’s analog outputs are working properly. The test generates a signal on functioning outputs simultaneously as shown in the following table. (See also Section 5.8.2).

Table 11-10: Analog Output Test Function - Nominal Values Voltage Outputs

		FULL SCALE OUTPUT OF VOLTAGE RANGE (see Section 0)			
		100MV	1V	5V	10V
STEP	%	NOMINAL OUTPUT VOLTAGE			
1	0	0	0	0	0
2	20	20 mV	0.2	1	2
3	40	40 mV	0.4	2	4
4	60	60 mV	0.6	3	6
5	80	80 mV	0.8	4	8
6	100	100 mV	1.0	5	10

For each of the steps the output should be within 1% of the nominal value listed in the table below except for the 0% step, which should be within 0mV ± 2 mV. Make sure

you take into account any offset that may have been programmed into channel (see Section 5.8.3.8).

If one or more of the steps fails to be within these ranges, it is likely that there has been a failure of either or both of the DACs and their associated circuitry on the motherboard. To perform the test connect a voltmeter to the output in question and perform an analog output step test as follows:

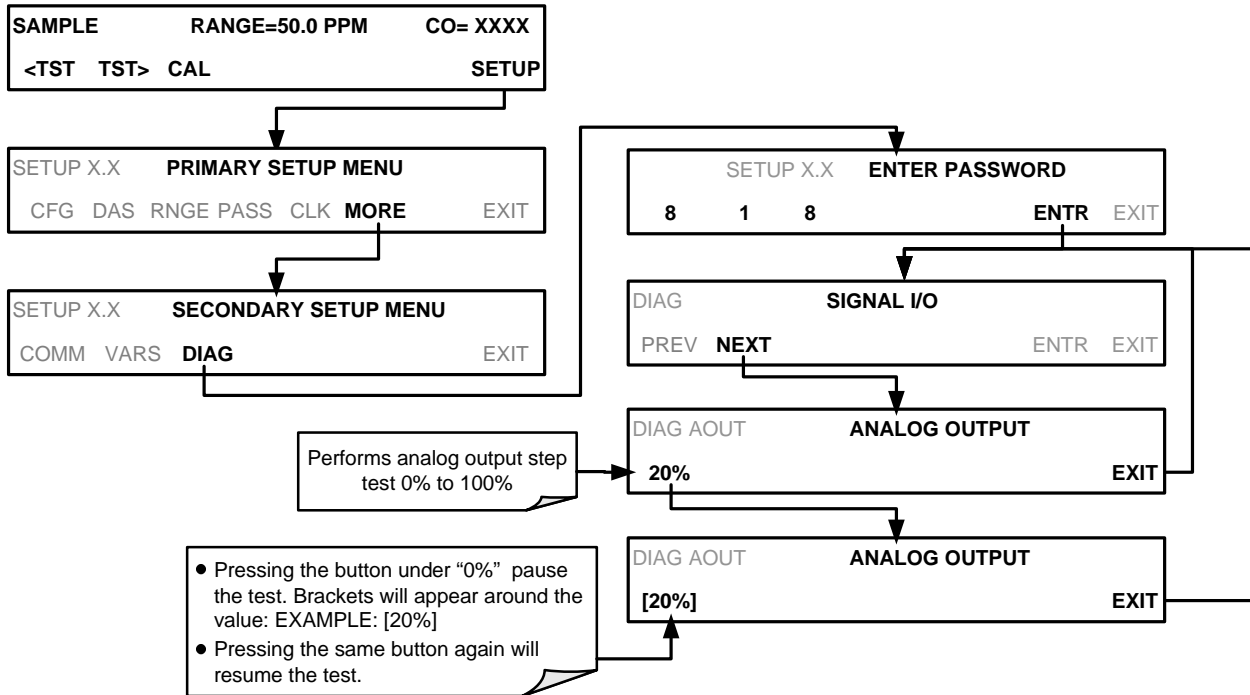

Note: The above screen(s) show CO concentration displayed. Your instrument will indicate and display N₂O concentration.

11.5.8.3. ANALOG OUTPUTS: CURRENT LOOP

To verify that the analog outputs with the optional current mode output are working properly, connect a 250 ohm resistor across the outputs and use a voltmeter to measure the output as described in Section 5.8.3.5 and then perform an analog output step test as described in Section 11.5.8.2.

For each step the output should be within 1% of the nominal value listed in the table below.

Table 11-11: Analog Output Test Function - Nominal Values Voltage Outputs

		OUTPUT RANGE			
		2 -20		4 -20	
		NOMINAL OUTPUT VALUES			
STEP	%	CURRENT	V(250 OHMS)	CURRENT	V(250 OHMS)
1	0	2 mA	0.5V	4	1
2	20	5.6	1.4	7.2	1.8

3	40	9.2	2.3	10.4	2.6
4	60	12.8	3.2	13.6	3.4
5	80	16.4	4.1	16.8	4.2
6	100	20	5	20	5

11.5.8.4. STATUS OUTPUTS

The procedure below can be used to test the Status outputs:

1. Connect a jumper between the “D” pin and the “∇” pin on the status output connector.
2. Connect a 1000 ohm resistor between the “+” pin and the pin for the status output that is being tested.
3. Connect a voltmeter between the “∇” pin and the pin of the output being tested (see table below).

Under the **DIAG** → SIGNAL I/O menu (see Section 11.1.3), scroll through the inputs and outputs until you get to the output in question. Alternately turn on and off the output noting the voltage on the voltmeter, it should vary between 0 volts for ON and 5 volts for OFF.

Table 11-12: Status Outputs Check

PIN (LEFT TO RIGHT)	STATUS
1	SYSTEM OK
2	CONC VALID
3	HIGH RANGE
4	ZERO CAL
5	SPAN CAL
6	DIAG MODE
7	SPARE
8	SPARE

11.5.8.5. CONTROL INPUTS – REMOTE ZERO, SPAN

The control input bits can be tested by the following procedure:

1. Jumper the +5 pin on the Status connector to the U on the Control In connector.
2. Connect a second jumper from the - pin on the Status connector to the A pin on the Control In connector. The instrument should switch from Sample Mode to ZERO CAL R mode.
3. Connect a second jumper from the - pin on the Status connector to the B pin on the Control In connector. The instrument should switch from Sample Mode to SPAN CAL R mode.
4. In each case, the GFC7002T/GFC7002TU should return to Sample Mode when the jumper is removed.

11.5.9. CPU

There are two major types of CPU board failures, a complete failure and a failure associated with the Disk On Module (DOM). If either of these failures occurs, contact the factory.

For complete failures, assuming that the power supplies are operating properly and the wiring is intact, the CPU is faulty if on power-on, the watchdog LED on the motherboard is not flashing.

In some rare circumstances, this failure may be caused by a bad IC on the motherboard, specifically U57, the large, 44 pin device on the lower right hand side of the board. If this is true, removing U57 from its socket will allow the instrument to start up but the measurements will be invalid.

If the analyzer stops during initialization (the front panel display shows a fault or warning message), it is likely that the DOM, the firmware or the configuration and data files have been corrupted.

11.5.10. RS-232 COMMUNICATIONS

11.5.10.1. GENERAL RS-232 TROUBLESHOOTING

TAI analyzers use the RS-232 communications protocol to allow the instrument to be connected to a variety of computer-based equipment. RS-232 has been used for many years and as equipment has become more advanced, connections between various types of hardware have become increasingly difficult. Generally, every manufacturer observes the signal and timing requirements of the protocol very carefully.

Problems with RS-232 connections usually center around the following general areas:

1. Incorrect cabling and connectors. See Section 3.3 for connector and pin-out information.
2. The BAUD rate and protocol are incorrectly configured. See Section 6.2.2.
3. If a modem is being used, additional configuration and wiring rules must be observed. See Section 8.3
4. Incorrect setting of the DTE-DCE Switch. Ensure that switch is set correctly. See Section 6.1.
5. Verify that cable (P/N 03596) that connects the serial COM ports of the CPU to J12 of the motherboard is properly seated.

11.5.10.2. TROUBLESHOOTING ANALYZER/MODEM OR TERMINAL OPERATION

These are the general steps for troubleshooting problems with a modem connected to a TAI analyzer.

1. Check cables for proper connection to the modem, terminal or computer.
2. Check to make sure the DTE-DCE is in the correct position as described in Section 6.1.
3. Check to make sure the set up command is correct. See Section 8.3.
4. Verify that the Ready to Send (RTS) signal is at logic high. The GFC7002T/GFC7002TU sets pin 7 (RTS) to greater than 3 volts to enable modem transmission.
5. Make sure the BAUD rate, word length, and stop bit settings between modem and analyzer match. See Section 8.3.
6. Use the RS-232 test function to send “w” characters to the modem, terminal or computer. See Section 8.3.
7. Get your terminal, modem or computer to transmit data to the analyzer (holding down the space bar is one way); the green LED should flicker as the instrument is receiving data.
8. Make sure that the communications software or terminal emulation software is functioning properly.

Further help with serial communications is available in a separate manual “RS-232 Programming Notes” TAI P/N 013500000.

11.5.11. THE OPTIONAL CO₂ SENSOR

There are Two LEDs located on the CO₂ sensor PCA.

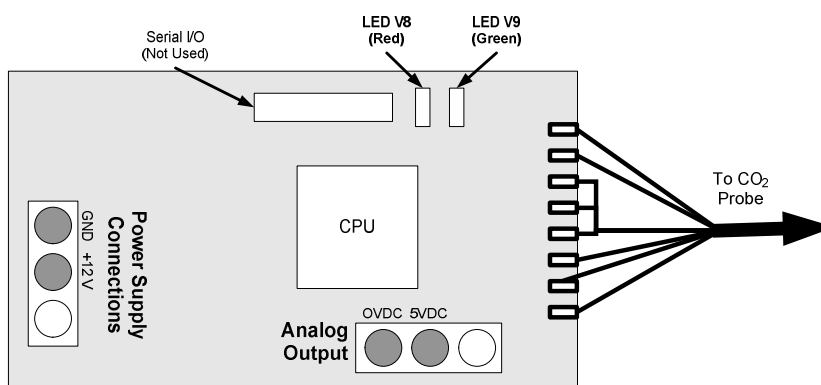

Figure 11-11: Location of Diagnostic LEDs on CO₂ Sensor PCA

- Normal Operation: V8 is not lit – V9 is Blinking
- Error State: Both LEDs are blinking.

Check to make sure that the cable to the CO₂ probe is properly connected.

11.6. REPAIR PROCEDURES

This contains procedures that might need to be performed on rare occasions when a major component of the analyzer requires repair or replacement.

11.6.1. REPAIRING SAMPLE FLOW CONTROL ASSEMBLY

The critical flow orifice is housed in the flow control assembly (TAI P/N 001760400) located on the top of the optical bench. A sintered filter protects the jewel orifice so it is unusual for the orifice to need replacing, but if it does, or the filter needs replacement please use the following procedure (see the Spare Parts list in Appendix B for part numbers and kits):

1. Turn off power to the analyzer.
2. Locate the assembly. See Figure 3-6.
3. Disconnect the pneumatic connection from the flow assembly and the assembly from the pump (if present)..
4. Remove the fitting and the components as shown in the exploded view below.
5. Replace the O-rings (P/N OR0000001) and the sintered filter (P/N FL0000001).
6. If replacing the critical flow orifice itself (P/N 000941000), make sure that the side with the colored window (usually red) is facing upstream to the flow gas flow.
7. Apply new Teflon[®] tape to the male connector threads.
8. Re-assemble in reverse order.
9. After reconnecting the power and pneumatic lines, flow check the instrument as described in Section 10.3.3.

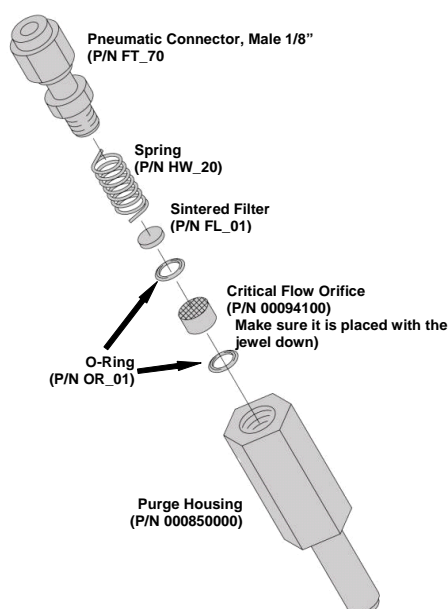

Figure 11-12: Critical Flow Restrictor Assembly/Disassembly

11.6.2. REMOVING/REPLACING THE GFC WHEEL

When removing or replacing the GFC Wheel it is important to perform the disassembly in the following order to avoid damaging the components:

1. Turn off the analyzer.
2. Remove the top cover.
3. Open the instrument's hinged front panel.
4. Locate the GFC Wheel/motor assembly. See Figure 3-6.
5. Unplug the following electronic components:
 - The GFC Wheel housing temperature sensor
 - GFC Wheel heater
 - GFC Wheel motor power supply

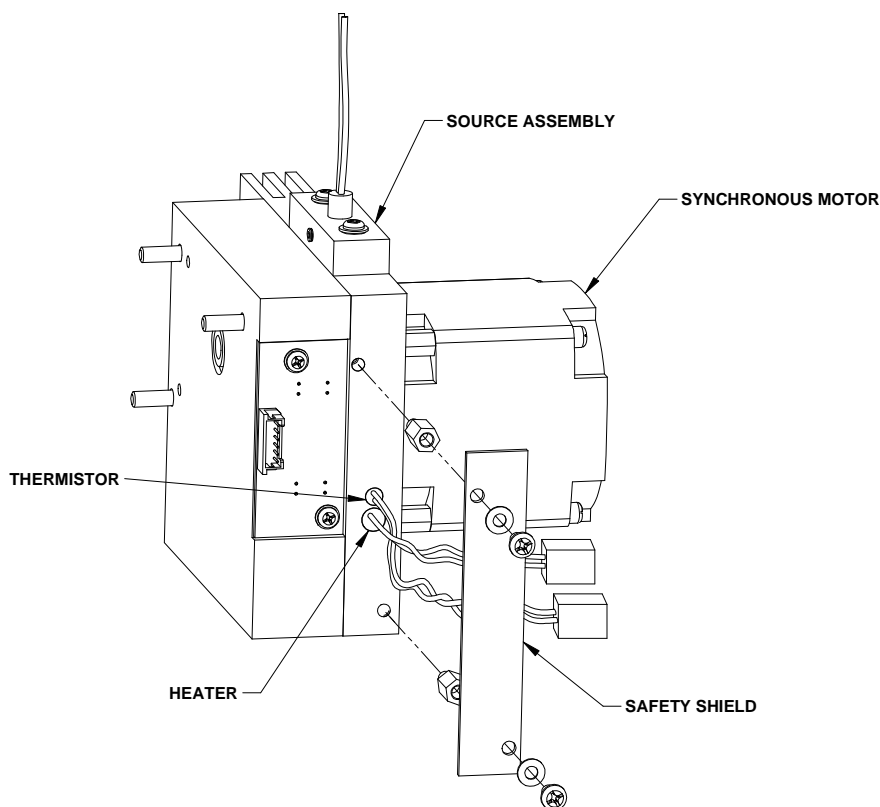

Figure 11-13: Opening the GFC Wheel Housing

6. Remove the two (2) screws holding the opto-pickup printed circuit assembly to the GFC Wheel housing.

7. Carefully remove the opto-pickup printed circuit assembly.

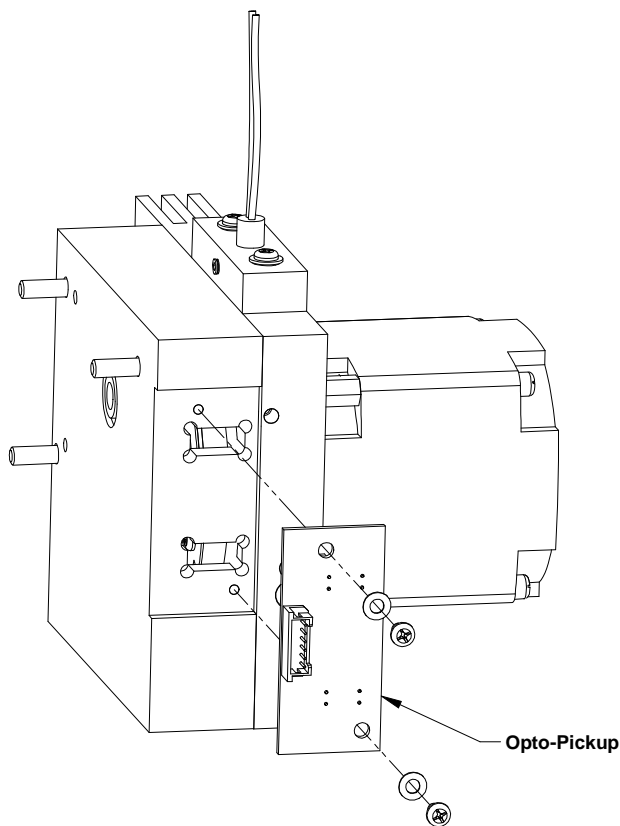

Figure 11-14: Removing the Opto-Pickup Assembly

8. Remove the three (3) screws holding the GFC Wheel motor/heat sink assembly to the GFC Wheel housing.
9. Carefully remove the GFC Wheel motor/heat sink assembly from the GFC Wheel housing.

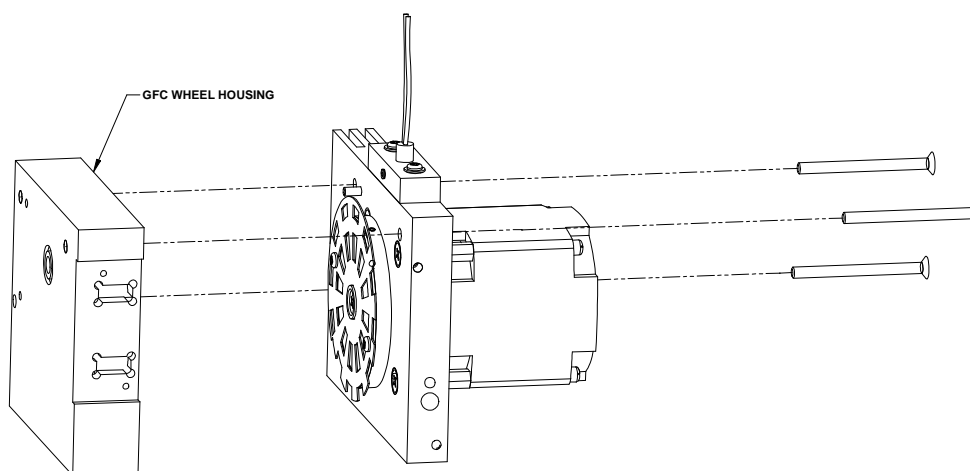

Figure 11-15: Removing the GFC Wheel Housing

10. Remove the one (1) screw fastening the GFC Wheel/mask assembly to the GFC motor hub.

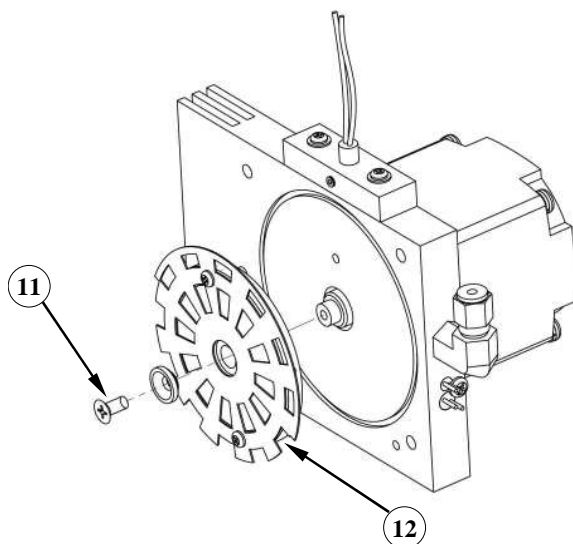

Figure 11-16: Removing the GFC Wheel

11. Remove the GFC Wheel/mask assembly.
12. Follow the previous steps in reverse order to put the GFC Wheel/motor assembly back together.

11.6.3. CHECKING AND ADJUSTING THE SYNC/DEMODULATOR, CIRCUIT GAIN (N₂O MEAS)

11.6.3.1. CHECKING THE SYNC/DEMODULATOR CIRCUIT GAIN

The GFC7002T/GFC7002TU Analyzers will operate accurately as long as the sync/demodulator circuit gain is properly adjusted. To determine if this gain factor is correct:

1. Make sure that the analyzer is turned on and warmed up.
2. Set the analyzer display to show the **STABIL** or **N2O STB** test function.
3. Apply Zero Air to Sample Inlet of the analyzer.
4. Wait until the stability reading falls below 1.0 ppm.
5. Change the analyzer display to show the **N2O MEAS**
 - The value of **N2O MEAS** must be > 2800 mV and < 4800 mV for the instrument to operate correctly.
 - Optimal value for **N2O MEAS** is 4500 mV ± 300 mV. If it is not, adjust the value.

11.6.3.2. ADJUSTING THE SYNC/DEMODULATOR, CIRCUIT GAIN

To adjust the sync/demodulator circuit gain:

1. Make sure that the analyzer is turned on and warmed up.
2. Set the analyzer display to show the **STABIL** or **N2O STB** test function.
3. Apply Zero Air to Sample Inlet of the analyzer.
4. Wait until the stability reading falls below 1.0 ppm.
5. Change the analyzer display to show the **N2O MEAS**.
6. Remove the Sync/Demod Housing
 - Remove the two mounting screws.
 - Carefully lift the housing to reveal the sync/demod PCA.

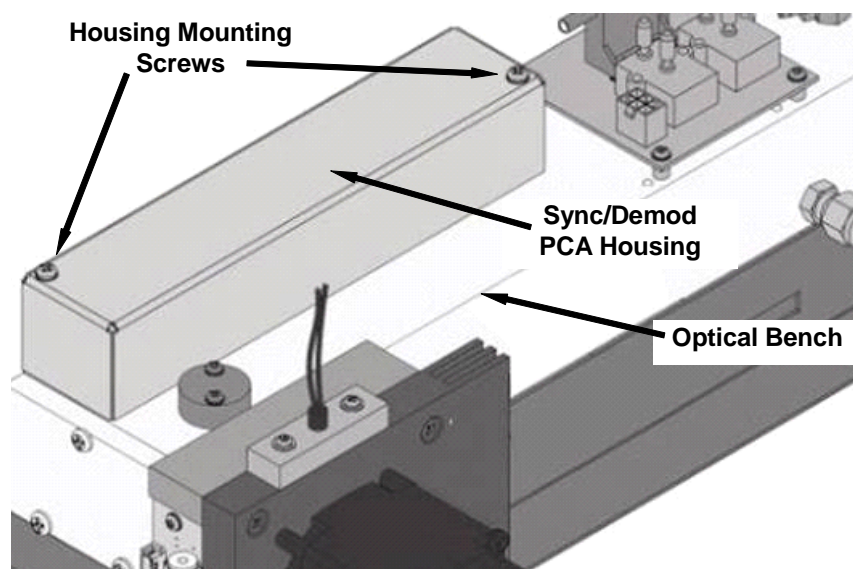

Figure 11-17: Location of Sync/Demod Housing Mounting Screws

7. Adjust potentiometer VR1 until **N2O MEAS** reads $4500\text{ mV} \pm 300\text{ mV}$

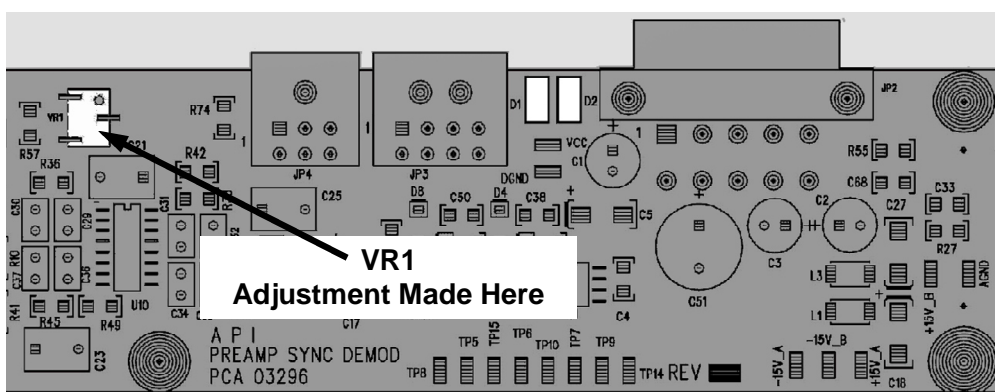

Figure 11-18: Location of Sync/Demod Gain Potentiometer

11.6.4. DISK-ON-MODULE REPLACEMENT

ATTENTION**-----
COULD DAMAGE INSTRUMENT AND VOID WARRANTY**

Servicing of circuit components requires electrostatic discharge protection, i.e. ESD grounding straps, mats and containers. Failure to use ESD protection when working with electronic assemblies will void the instrument warranty. Refer to Section 13 for more information on preventing ESD damage.

Replacing the Disk-on-Module (DOM) will cause loss of all DAS data; it may also cause loss of some instrument configuration parameters unless the replacement DOM carries the exact same firmware version. Whenever changing the version of installed software, the memory must be reset. Failure to ensure that memory is reset can cause the analyzer to malfunction, and invalidate measurements. After the memory is reset, the A/D converter must be re-calibrated, and all information collected in Step 1 below must be re-entered before the instrument will function correctly. Also, zero and span calibration should be performed.

1. Document all analyzer parameters that may have been changed, such as range, auto-cal, analog output, serial port and other settings before replacing the DOM
2. Turn off power to the instrument, fold down the rear panel by loosening the mounting screws.
3. When looking at the electronic circuits from the back of the analyzer, locate the Disk-on-Module in the right-most socket of the CPU board.
4. The DOM should carry a label with firmware revision, date and initials of the programmer.
5. Remove the nylon standoff clip that mounts the DOM over the CPU board, and lift the DOM off the CPU. Do not bend the connector pins.
6. Install the new Disk-on-Module, making sure the notch at the end of the chip matches the notch in the socket.
7. It may be necessary to straighten the pins somewhat to fit them into the socket. Press the chip all the way in.
8. Close the rear panel and turn on power to the machine.
9. If the replacement DOM carries a firmware revision, re-enter all of the setup information.

11.7. FREQUENTLY ASKED QUESTIONS

The following is a list from Teledyne’s Customer Service Department of the most commonly asked questions relating to the GFC7002T/GFC7002TU N₂O Analyzer.

QUESTION	ANSWER
<p>Why does the ENTR button sometimes disappear on the Front Panel Display?</p>	<p>During certain types of adjustments or configuration operations, the ENTR button will disappear if you select a setting that is out of the allowable range for that parameter (such as trying to set the 24-hour clock to 25:00:00, or selecting a DAS hold off period of more than 20 minutes).</p> <p>Once you adjust the setting in question to an allowable value, the ENTR button will re-appear.</p>
<p>Why is the ZERO or SPAN button not displayed during calibration?</p>	<p>The GFC7002T/GFC7002TU disables these buttons when the expected span or zero value entered by the users is too different from the gas concentration actually measured value at the time. This is to prevent the accidental recalibration of the analyzer to an out-of-range response curve.</p> <p>EXAMPLE: The span set point is 40 ppm but gas concentration being measured is only 5 ppm.</p> <p>For more information, see Sections 11.3.3 and 11.3.4.</p>
<p>How do I enter or change the value of my Span Gas?</p>	<p>Press the CONC button found under the CAL or CALS buttons of the main SAMPLE display menus to enter the expected N₂O span concentration.</p> <p>See Section 0 for more information.</p>
<p>Why does the analyzer not respond to span gas?</p>	<p>There could be something wrong with a span gas tank, or a span gas concentration was entered incorrectly, or there could be a pneumatic leak. Section 11.3.3 addresses these issues.</p>
<p>Is there an optional midpoint calibration?</p>	<p>There is an optional mid-point linearity adjustment; however, midpoint adjustment is applicable only to applications where N₂O measurements are expected above 100 ppm.</p> <p>Call Teledyne Customer Service Department for more information on this topic.</p>
<p>What do I do if the concentration on the instrument's front panel display does not match the value recorded or displayed on my data logger even if both instruments are properly calibrated?</p>	<p>This most commonly occurs for one of the following reasons:</p> <ul style="list-style-type: none"> • A difference in circuit ground between the analyzer and the data logger or a wiring problem • A scale problem with the input to the data logger (The analog outputs of the GFC7002T/GFC7002TU can be manually adjusted to compensate for either or both of these effects, see Section 5.8.3.8). • The analog outputs are not calibrated, which can happen after a firmware upgrade (Both the electronic scale and offset of the analog outputs can be adjusted; see Section 5.8.3.1. Alternately, use the data logger itself as the metering device during calibration procedures.

QUESTION	ANSWER
How do I perform a leak check?	Section 10.3.2 provides leak check instructions.
How do I measure the sample flow?	Sample flow is measured by attaching a calibrated rotameter, wet test meter, or other flow-measuring device to the sample inlet port when the instrument is operating. The sample flow should be 800 cm ³ /min ±10%. See Section 10.3.3.
How long does the IR source last?	Typical lifetime is about 2-3 years.
Can I automate the calibration of my analyzer?	Any analyzer with zero/span valve or IZS option can be automatically calibrated using the instrument's AutoCal feature. The setup of this option is located in Section 9.3.
Can I use the IZS option to calibrate the analyzer?	<p>Yes. However, whereas this may be acceptable for basic calibration checks, the IZS option is not permitted as a calibration source in applications following US EPA protocols.</p> <p>To achieve highest accuracy, it is recommended to use cylinders of calibrated span gases in combination with a zero air source.</p>
<p>Q: What is the averaging time for an GFC7002T/GFC7002TU?</p>	<p>A: The default averaging time, optimized for ambient pollution monitoring, is 150 seconds for stable concentrations and 10 seconds for rapidly changing concentrations (see Section 12.5.1 for more information).</p> <p>However, it is adjustable over a range of 0.5 second to 200 seconds (please contact Customer Service for more information).</p>

11.8. TECHNICAL ASSISTANCE

If this manual and its troubleshooting / repair sections do not solve your problems, technical assistance may be obtained from:

TELEDYNE ELECTRONIC TECHNOLOGIES
Analytical Instruments

16830 Chestnut Street
 City of Industry, CA 91748

Telephone: (626) 934-1500
 Fax: (626) 961-2538

Web: www.teledyne-ai.com
 or your local representative.

Before you contact TAI Customer Service, fill out the problem report form in Appendix C.

This page intentionally left blank.

12. THEORY OF OPERATION

The GFC7002T/GFC7002TU Gas Filter Correlation Carbon monoxide Analyzer is a microprocessor-controlled analyzer that determines the concentration of nitrous oxide (N₂O) in a sample gas drawn through the instrument. It requires that the sample and calibration gases be supplied at, or very close to, ambient atmospheric pressure in order to establish a stable gas flow through the sample chamber where the gases ability to absorb infrared radiation is measured.

Calibration of the instrument is performed in software and does not require physical adjustments to the instrument. During calibration, the microprocessor measures the current state of the IR Sensor output and various other physical parameters of the instrument and stores them in memory.

The microprocessor uses these calibration values, the IR absorption measurements made on the sample gas along with data regarding the current temperature and pressure of the gas to calculate a final N₂O concentration.

This concentration value and the original information from which it was calculated are stored in one of the unit's internal data acquisition system (DAS - See Sections 7) as well as reported to the user via front panel display display or a variety of digital and analog signal outputs.

12.1. MEASUREMENT METHOD

This section presents measurement principles and fundamentals for this instrument.

12.1.1. BEER'S LAW

The basic principle by which the analyzer works is called the Beer-Lambert Law or Beer's Law. It defines how light of a specific wavelength is absorbed by a particular gas molecule over a certain distance. The mathematical relationship between these three parameters is:

$$I = I_0 e^{-\alpha Lc}$$

Equation 12-1

Where:

I_0 is the intensity of the light if there was no absorption.

I is the intensity with absorption.

L is the absorption path, or the distance the light travels as it is being absorbed.

C is the concentration of the absorbing gas; in the case of the GFC7002T/GFC7002TU, Nitrous Oxide (N₂O).

α is the absorption coefficient that tells how well N₂O absorbs light at the specific wavelength of interest.

12.2. MEASUREMENT FUNDAMENTALS

In the most basic terms, the GFC7002T/GFC7002TU uses a high-energy heated element to generate a beam of broad-band IR light with a known intensity (measured during instrument calibration). This beam is directed through multi-pass cell filled with sample gas. The sample cell uses mirrors at each end to reflect the IR beam back and forth through the sample gas a number of times (see Figure 12-1).

The total length that the reflected light travels is directly related to the intended sensitivity of the instrument. The lower the concentration that the instrument is designed to detect, the longer the light path must be in order to create detectable levels of attenuation.

Lengthening the absorption path is accomplished partly by making the physical dimension of the reaction cell longer, but primarily by adding extra passes back and forth along the length of the chamber.

Table 12-1: Absorption Path Lengths for GFC7002T and GFC7002TU

MODEL	TOTAL NUMBER OF REFLECTIVE PASSES	DISTANCE BETWEEN MIRRORS	TOTAL ABSORPTION LIGHT PATH
GFC7002T	32	437.5 mm	14 Meters
GFC7002TU	8	312.5 mm	2.5 Meters

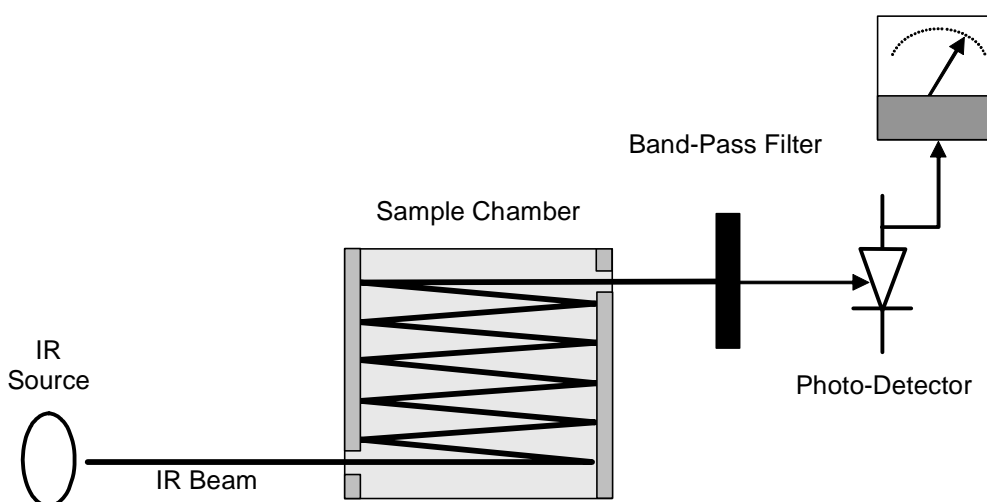

Figure 12-1: Measurement Fundamentals

Upon exiting the sample cell, the beam shines through a band-pass filter that allows only light at a wavelength of 4.58 μm to pass. Finally, the beam strikes a solid-state photo-

detector that converts the light signal into a modulated voltage signal representing the attenuated intensity of the beam.

12.2.1. GAS FILTER CORRELATION

Unfortunately, water vapor absorbs light at 4.58 μm too. To overcome the interfering effects of water vapor the GFC7002T/GFC7002TU adds another component to the IR light path called a Gas Filter Correlation (GFC) Wheel.

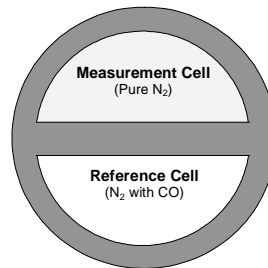

Figure 12-2: GFC Wheel

12.2.1.1. THE GFC WHEEL

A GFC Wheel is a metallic wheel into which two chambers are carved. The chambers are sealed on both sides with material transparent to 4.58 μm IR radiation creating two airtight cavities. Each cavity is mainly filled with composed gases. One cell is filled with pure N₂ (the measurement cell). The other is filled with a combination of N₂ and a high concentration of N₂O (the reference cell).

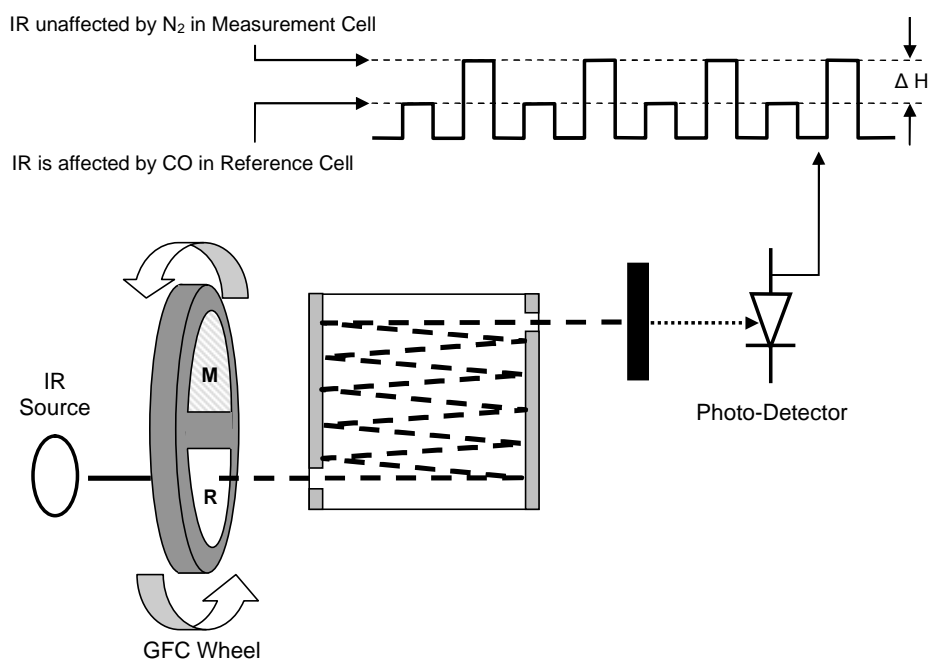

Figure 12-3: Measurement Fundamentals with GFC Wheel

As the GFC Wheel spins, the IR light alternately passes through the two cavities. When the beam is exposed to the reference cell, the N₂O in the gas filter wheel strips the beam of most of the IR at 4.58 μ m. When the light beam is exposed to the measurement cell, the N₂ in the filter wheel does not absorb IR light. This causes a fluctuation in the intensity of the IR light striking the photo-detector which results in the output of the detector resembling a square wave.

12.2.1.2. THE MEASURE REFERENCE RATIO

The GFC7002T/GFC7002TU determines the amount of N₂O in the sample chamber by computing the ratio between the peak of the measurement pulse (**N₂O MEAS**) and the peak of the reference pulse (**N₂O REF**).

If no gases exist in the sample chamber that absorb light at 4.58 μ m, the high concentration of N₂O in the gas mixture of the reference cell will attenuate the intensity of the IR beam by 60% giving a M/R ratio of approximately 2.4:1.

Adding N₂O to the sample chamber causes the peaks corresponding to both cells to be attenuated by a further percentage. Since the intensity of the light passing through the measurement cell is greater, the effect of this additional attenuation is greater. This causes **N₂O MEAS** to be more sensitive to the presence of N₂O in the sample chamber than **N₂O REF** and the ratio between them (M/R) to move closer to 1:1 as the concentration of N₂O in the sample chamber increases.

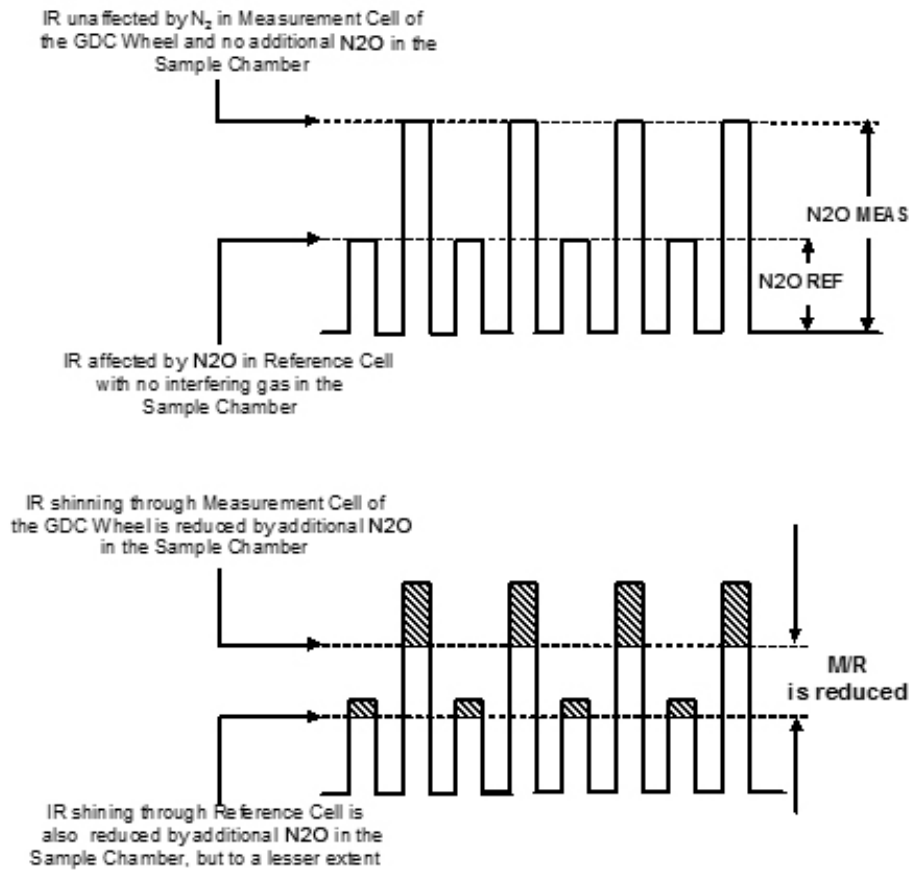

Figure 12-4: Affect of N₂O in the Sample on N₂O MEAS & N₂O REF

Once the GFC7002T/GFC7002TU has computed this ratio, a look-up table is used, with interpolation, to linearize the response of the instrument. This linearized concentration value is combined with calibration SLOPE and OFFSET values to produce the N₂O concentration which is then normalized for changes in sample pressure.

INTERFERENCE AND SIGNAL TO NOISE REJECTION

If an interfering gas, such as H₂O vapor is introduced into the sample chamber, the spectrum of the IR beam is changed in a way that is identical for both the reference and the measurement cells, but without changing the ratio between the peak heights of N₂O MEAS and N₂O REF. In effect, the difference between the peak heights remains the same.

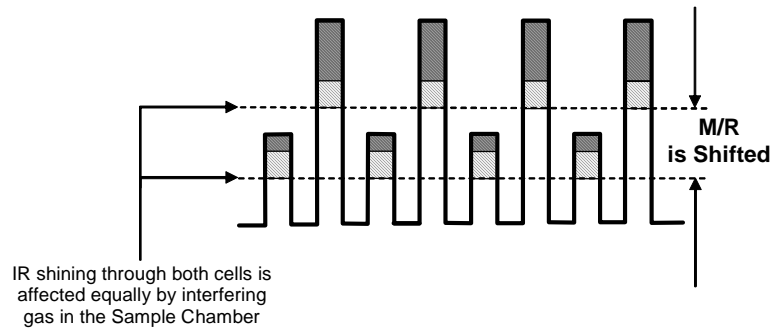

Figure 12-5: Effects of Interfering Gas on N₂O MEAS & N₂O REF

Thus, the difference in the peak heights and the resulting M/R ratio is only due to N₂O and not to interfering gases. In this case, GFC rejects the effects of interfering gases and so that the analyzer responds only to the presence of N₂O.

To improve the signal-to-noise performance of the IR photo-detector, the GFC Wheel also incorporates an optical mask that chops the IR beam into alternating pulses of light and dark at six times the frequency of the measure/reference signal. This limits the detection bandwidth helping to reject interfering signals from outside this bandwidth improving the signal to noise ratio.



Figure 12-6: Chopped IR Signal

12.2.1.3. SUMMARY INTERFERENCE REJECTION

The basic design of the GFC7002T/GFC7002TU rejects most of this interference at a 300:1 ratio. The two primary methods used to accomplish this are:

- The 4.58 μ m band pass filter just before the IR sensor which allows the instrument to only react to IR absorption in the wavelength affected by N₂O.
- Comparison of the measure and reference signals and extraction of the ratio between them.
- Pneumatic Operation



CAUTION – GENERAL SAFETY HAZARD

It is important that the sample airflow system is both leak tight and not pressurized over ambient pressure.

Regular leak checks should be performed on the analyzer as described in the maintenance schedule, Table 10-1.

Procedures for correctly performing leak checks can be found in Section 10.3.2.

The sample gas is to be made available to the analyzer at a pressure slightly above ambient but sufficient to allow for a proper flow through the sample lines. The internal sample system has been designed with minimal restriction allowing sufficient flow at very low pressure. The input pressure must be reduced and regulated from the process pressure using a pressure regulator, needle valve, restrictor, critical orifice or any combination thereof before entering the analyzer. .

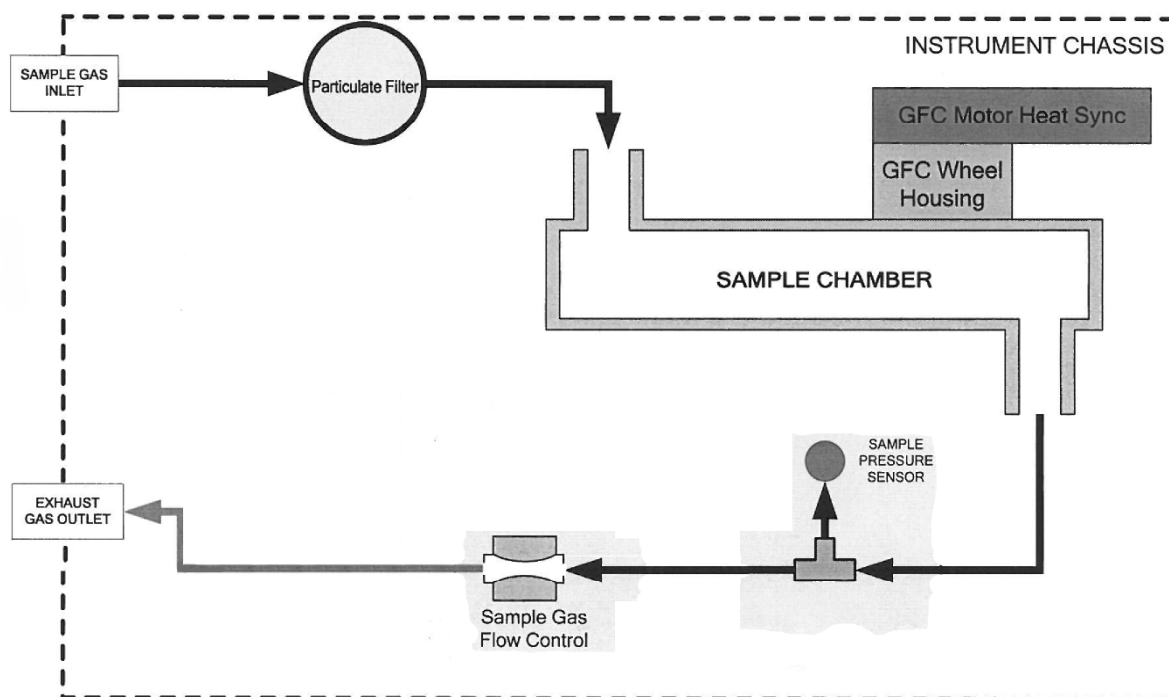

Figure 12-7: Internal Pneumatic Flow – Basic Configuration

12.3. FLOW RATE CONTROL

To maintain a constant flow rate of the sample gas through the instrument, the GFC7002T/GFC7002TU uses a special flow control assembly located in the exhaust gas line. In instruments with the O₂ sensor installed, a second flow control assembly is located between the O₂ sensor assembly and the exhaust port. These assemblies consist of:

- A critical flow orifice.
- Two O-rings: Located just before and after the critical flow orifice, the O-rings seal the gap between the walls of assembly housing and the critical flow orifice.
- A spring: Applies mechanical force needed to form the seal between the O-rings, the critical flow orifice and the assembly housing.

12.3.1.1. CRITICAL FLOW ORIFICE

The most important component of this flow control assembly is the critical flow orifice.

Critical flow orifices are a remarkably simple way to regulate stable gas flow rates. They operate without moving parts by taking advantage of the laws of fluid dynamics. By restricting the flow of gas through the orifice, a pressure differential is created.

As the pressure on the downstream side of the orifice continues to drop, the speed that the gas flows through the orifice continues to rise. Once the ratio of upstream pressure to downstream pressure is greater than 2:1, the velocity of the gas through the orifice reaches the speed of sound. As long as that ratio stays at least 2:1, the gas flow rate is unaffected by any fluctuations, surges, or changes in downstream pressure because such variations only travel at the speed of sound themselves and are therefore cancelled out by the sonic shockwave at the downstream exit of the critical flow orifice.

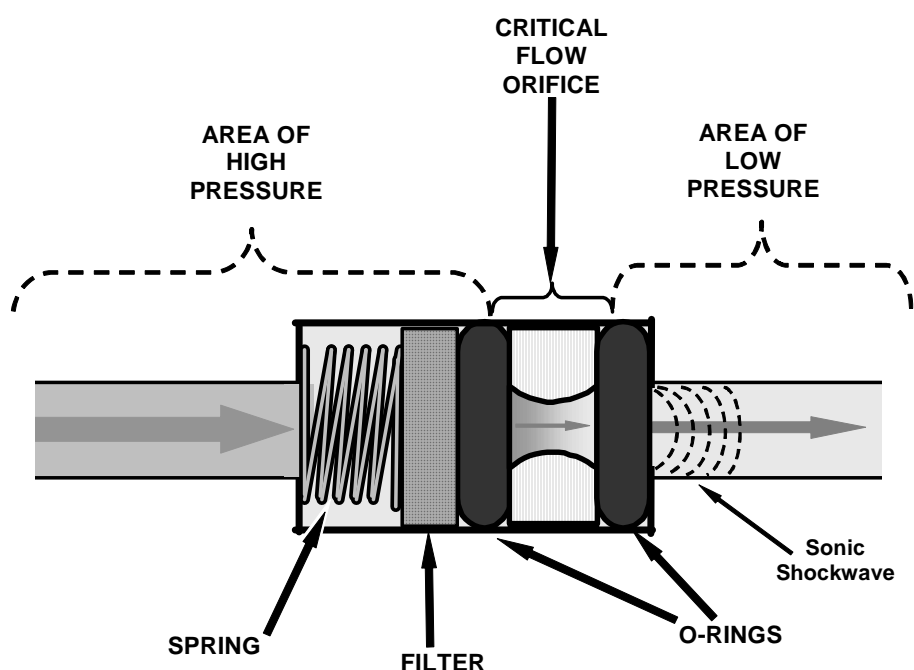

Figure 12-8: Flow Control Assembly & Critical Flow Orifice

The actual flow rate of gas through the orifice (volume of gas per unit of time), depends on the size and shape of the aperture in the orifice. The larger the hole, the more the gas molecules move at the speed of sound and pass through the orifice. Because the flow rate of gas through the orifice is only related to the minimum 2:1 pressure differential and not absolute pressure, the flow rate of the gas is also unaffected by ambient pressure fluctuations downstream.

The critical flow orifice used in the GFC7002T/GFC7002TU is designed to provide a flow rate of 800 cc/min.

12.3.2. PARTICULATE FILTER

The GFC7002T/GFC7002TU Analyzer comes equipped with a 47 mm diameter, Teflon, particulate filter with a 5 micron pore size. The filter is accessible through the front panel, which folds down to allow access, and should be changed according to the suggested maintenance schedule described in Table 10-1.

12.3.3. PNEUMATIC SENSORS

There are two pneumatic sensors: one each to measure sample pressure and flow.

12.3.3.1. SAMPLE PRESSURE SENSOR

An absolute value pressure transducer plumbed to the outlet of the sample chamber is used to measure sample pressure. The output of the sensor is used to compensate the concentration measurement for changes in air pressure. This sensor is mounted to a printed circuit board with the Sample Flow Sensor on the sample chamber (see Section 12.3.3.2 and Figure 3-4).

12.3.3.2. SAMPLE FLOW SENSOR

A thermal-mass flow sensor is used to measure the sample flow through the analyzer. The sensor is calibrated at the factory with ambient air or N₂, but can be calibrated to operate with samples consisting of other gases such as N₂O. This sensor is mounted to a printed circuit board with the Sample Pressure Sensor on the sample chamber (see Section 12.3.3.1 and Figure 3-4).

12.4. ELECTRONIC OPERATION

Figure 12-9 shows a block diagram of the major electronic components of the analyzer.

The core of the analyzer is a microcomputer/central processing unit (CPU) that controls various internal processes, interprets data, makes calculations, and reports results using specialized firmware developed by TAI. It communicates with the user as well as receives data from and issues commands to a variety of peripheral devices via a separate printed circuit assembly called the motherboard.

The motherboard is directly mounted to the inside rear panel and collects data, performs signal conditioning duties and routes incoming and outgoing signals between the CPU and the analyzer's other major components.

Data are generated by a gas-filter-correlation optical bench which outputs an analog signal corresponding to the concentration of N₂O in the sample gas. This analog signal is transformed into two, pre-amplified, DC voltages (**N₂O MEAS** and **N₂O REF**) by a synchronous demodulator printed circuit assembly. **N₂O MEAS** and **N₂O REF** are converted into digital data by a unipolar, analog-to-digital converter, located on the motherboard.

A variety of sensors report the physical and operational status of the analyzer's major components, again through the signal processing capabilities of the motherboard. These status reports are used as data for the N₂O concentration calculation and as trigger events for certain control commands issued by the CPU. This information is stored in memory by the CPU and in most cases can be viewed but the user via the front panel display.

The CPU issues commands via a series of relays and switches (also over the I²C bus) located on a separate printed circuit assembly to control the function of key electromechanical devices such as heaters, motors and valves.

The CPU communicates with the user and the outside world in several ways:

- Through the analyzer's front panel LCD touch-screen interface
- RS-232 and RS-485 serial I/O channels

- Various analog voltage and current outputs
- Several digital I/O channels
- Ethernet

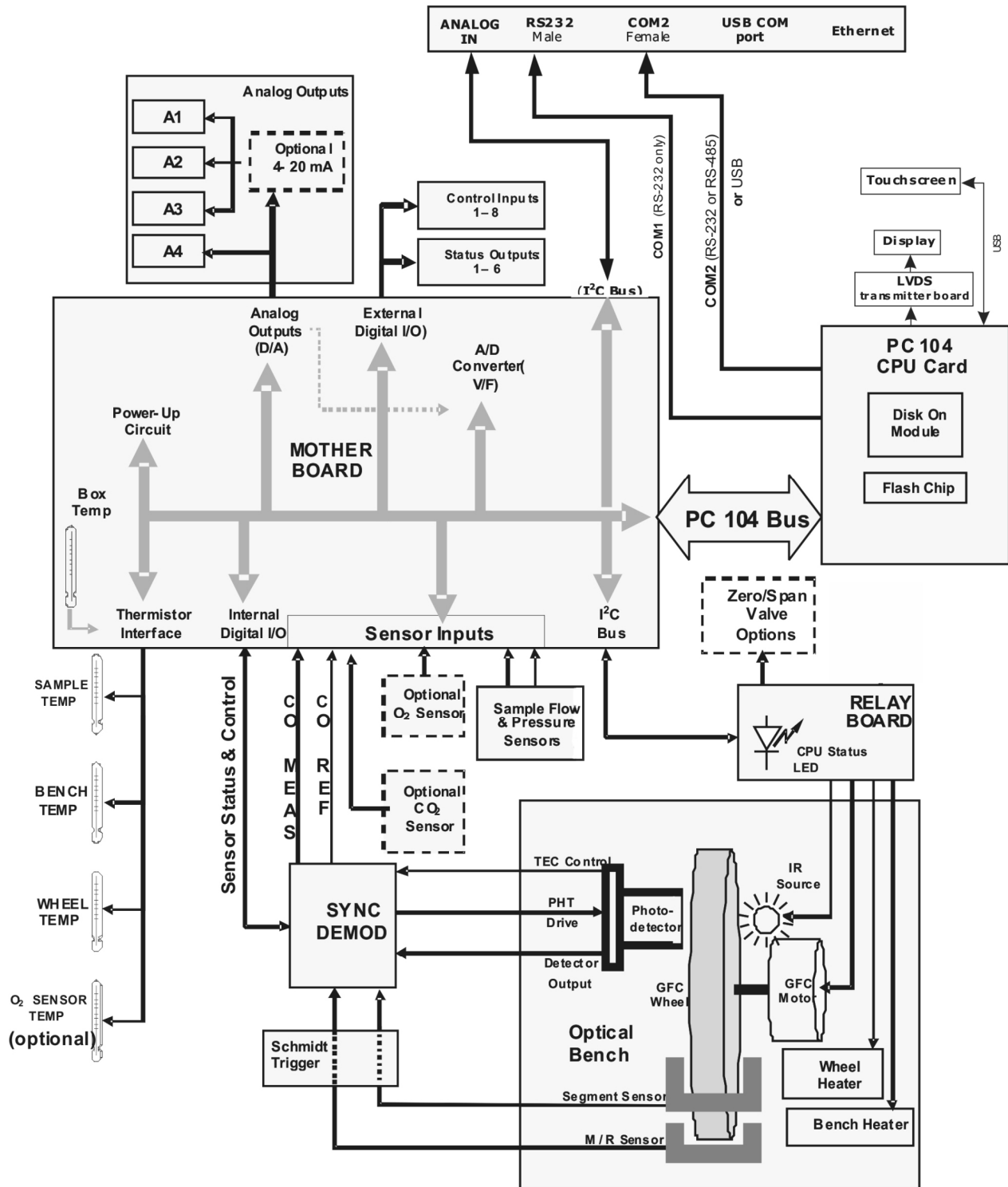

Figure 12-9: Electronic Block Diagram

12.4.1. CPU

The unit's CPU card is installed on the motherboard located inside the rear panel. It is a low power (5 VDC, 720mA max), high performance, Vortex 86SX-based microcomputer running Windows CE. Its operation and assembly conform to the PC/104 specification.

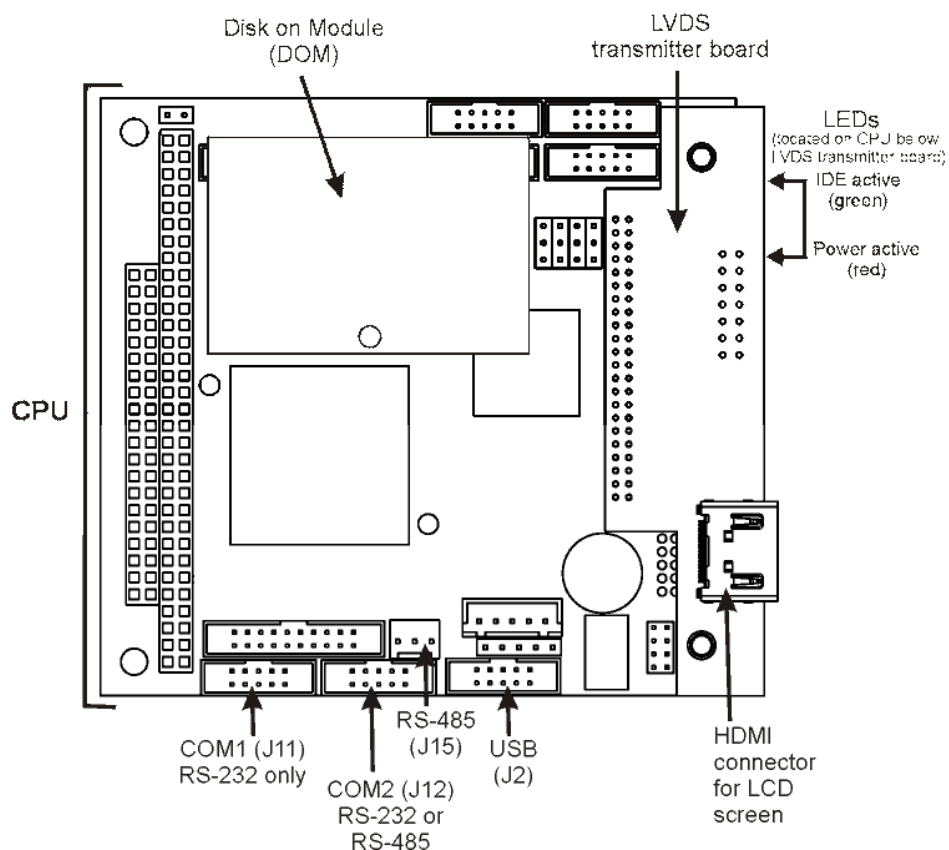

Figure 12-10. CPU Board

The CPU includes two types of non-volatile data storage: a Disk-On-Module (DOM) and an embedded flash chip.

12.4.1.1. DISK-ON-MODULE (DOM)

The DOM is a 44-pin IDE flash drive with a storage capacity up to 128 MB. It is used to store the computer's operating system, the TAI firmware, and most of the operational data generated by the analyzer's internal data acquisition system (DAS).

12.4.1.2. FLASH CHIP

This non-volatile, embedded flash chip includes 2MB of storage for calibration data as well as a backup of the analyzer configuration. Storing these key data on a less heavily accessed chip significantly decreases the chance of data corruption.

In the unlikely event that the flash chip should fail, the analyzer will continue to operate with just the DOM. However, all configuration information will be lost, requiring that the unit be recalibrated.

12.4.2. OPTICAL BENCH & GFC WHEEL

Electronically, in the case of the optical bench for the GFC7002T Analyzer, GFC Wheel and associated components do more than simply measure the amount of N₂O present in the sample chamber. A variety of other critical functions are performed here as well.

12.4.2.1. TEMPERATURE CONTROL

Because the temperature of a gas affects its density resulting in the amount of light absorbed by that gas, it is important to reduce the effect of fluctuations in ambient temperature on the GFC7002T's measurement of N₂O for the GFC7002T Analyzer. To accomplish this both the temperature of the sample chamber and the GFC Wheel are maintained at constant temperatures above their normal operating ranges.

BENCH TEMPERATURE

To minimize the effects of ambient temperature variations on the sample measurement, the sample chamber is heated to 48°C (8 degrees above the maximum suggested ambient operating temperature for the analyzer). A strip heater attached to the underside of the chamber housing is the heat source. The temperature of the sample chamber is sensed by a thermistor, also attached to the sample chamber housing.

WHEEL TEMPERATURE

To minimize the effects of temperature variations caused by the near proximity of the IR Source to the GFC Wheel on the gases contained in the wheel, it is also raised to a high temperature level. Because the IR Source itself is very hot, the set point for this heat circuit is 68°C. A cartridge heater implanted into the heat sync on the motor is the heat source. The temperature of the wheel/motor assembly is sensed by a thermistor also inserted into the heat sync.

Both heaters operate off of the AC line voltage supplied to the instrument.

12.4.2.2. IR SOURCE

The light used to detect N₂O in the sample chamber is generated by an element heated to approximately 1100°C producing infrared radiation across a broad band. This radiation is optically filtered after it has passed through the GFC Wheel and the sample chamber and just before it reaches the photo-detector to eliminate all black body radiation and other extraneous IR emitted by the various components of those components.

12.4.2.3. GFC WHEEL

A synchronous AC motor turns the GFC Wheel motor. For analyzers operating on 60Hz line power this motor turns at 1800 rpm. For those operating on 50Hz line power the spin rate is 1500 rpm. The actual spin rate is unimportant within a large range since a phase lock loop circuit is used to generate timing pulses for signal processing.

In order to accurately interpret the fluctuations of the IR beam after it has passed through the sample gas, the GFC Wheel several other timing signals are produced by

other photo emitters/detectors. These devices consist of a combination LED and detector mounted so that the light emitted by the LED shines through the same mask on the GFC Wheel that chops the IR beam.

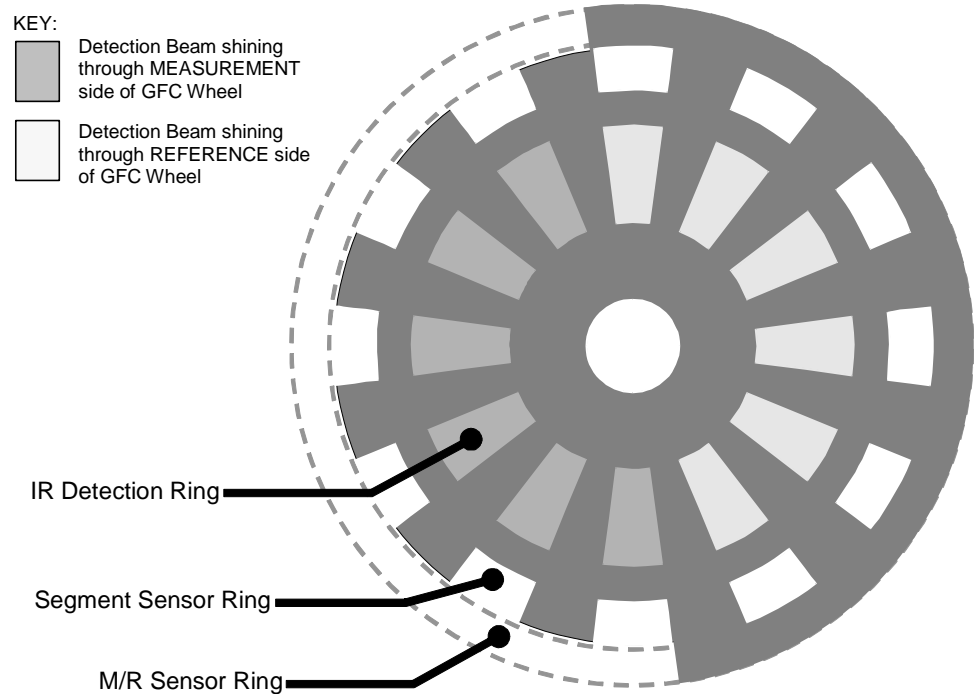

Figure 12-11: GFC Light Mask

M/R SENSOR

This emitter/detector assembly produces a signal that shines through a portion of the mask that allows light to pass for half of a full revolution of the wheel. The resulting light signal tells the analyzer whether the IR beam is shining through the measurement or the reference side of the GFC Wheel.

SEGMENT SENSOR

Light from this emitter/detector pair shines through a portion of the mask that is divided into the same number of segments as the IR detector ring. It is used by the synchronous/demodulation circuitry of the analyzer to latch onto the most stable part of each measurement and reference IR pulse.

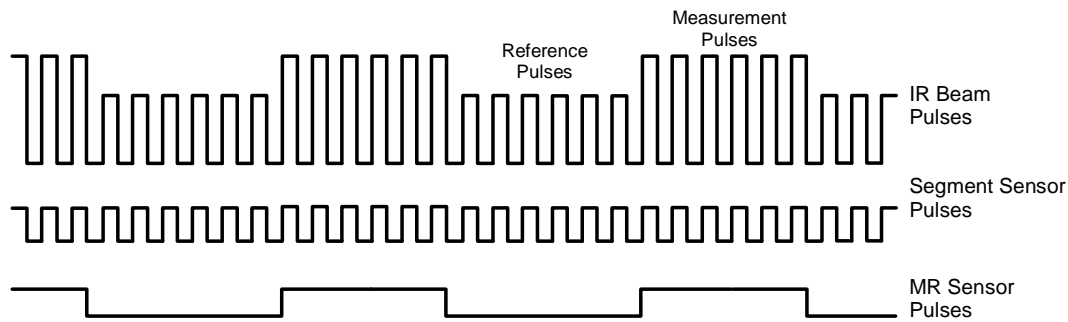

Figure 12-12: Segment Sensor and M/R Sensor Output

SCHMIDT TRIGGERS

To ensure that the waveforms produced by the Segment Sensor and the M/R Sensor are properly shaped and clean, these signals are passed through a set of Schmidt Triggers circuits.

12.4.2.4. IR PHOTO-DETECTOR

The IR beam is converted into an electrical signal by a cooled solid-state photo-conductive detector. The detector is composed of a narrow-band optical filter, a piece of lead-salt crystal whose electrical resistance changes with temperature, and a two-stage thermo-electric cooler.

When the analyzer is on, a constant electrical current is directed through the detector. The IR beam is focused onto the detector surface, raising its temperature and lowering its electrical resistance that results in a change in the voltage drop across the detector.

During those times that the IR beam is bright, the temperature of the detector is high; the resistance of the detector is correspondingly low and its output voltage output is low. During those times when the IR beam intensity is low or completely blocked by the GFC Wheel mask, the temperature of the detector is lowered by the two-stage thermo-electric cooler, increasing the detector's resistance and raising the output voltage.

12.4.3. SYNCHRONOUS DEMODULATOR (SYNC/DEMODO) ASSEMBLY

While the photo-detector converts fluctuations of the IR beam into electronic signals, the Sync/Demod Board amplifies these signals and converts them into usable information. Initially the output by the photo-detector is a complex and continuously changing waveform made up of Measure and Reference pulses. The sync/demod board demodulates this waveform and outputs two analog DC voltage signals, corresponding to the peak values of these pulses. **N₂O MEAS** and **N₂O REF** are converted into digital signals by circuitry on the motherboard then used by the CPU to calculate the N₂O concentration of the sample gas.

Additionally the synch/demod board contains circuitry that controls the photo-detector's thermoelectric cooler as well as circuitry for performing certain diagnostic tests on the analyzer.

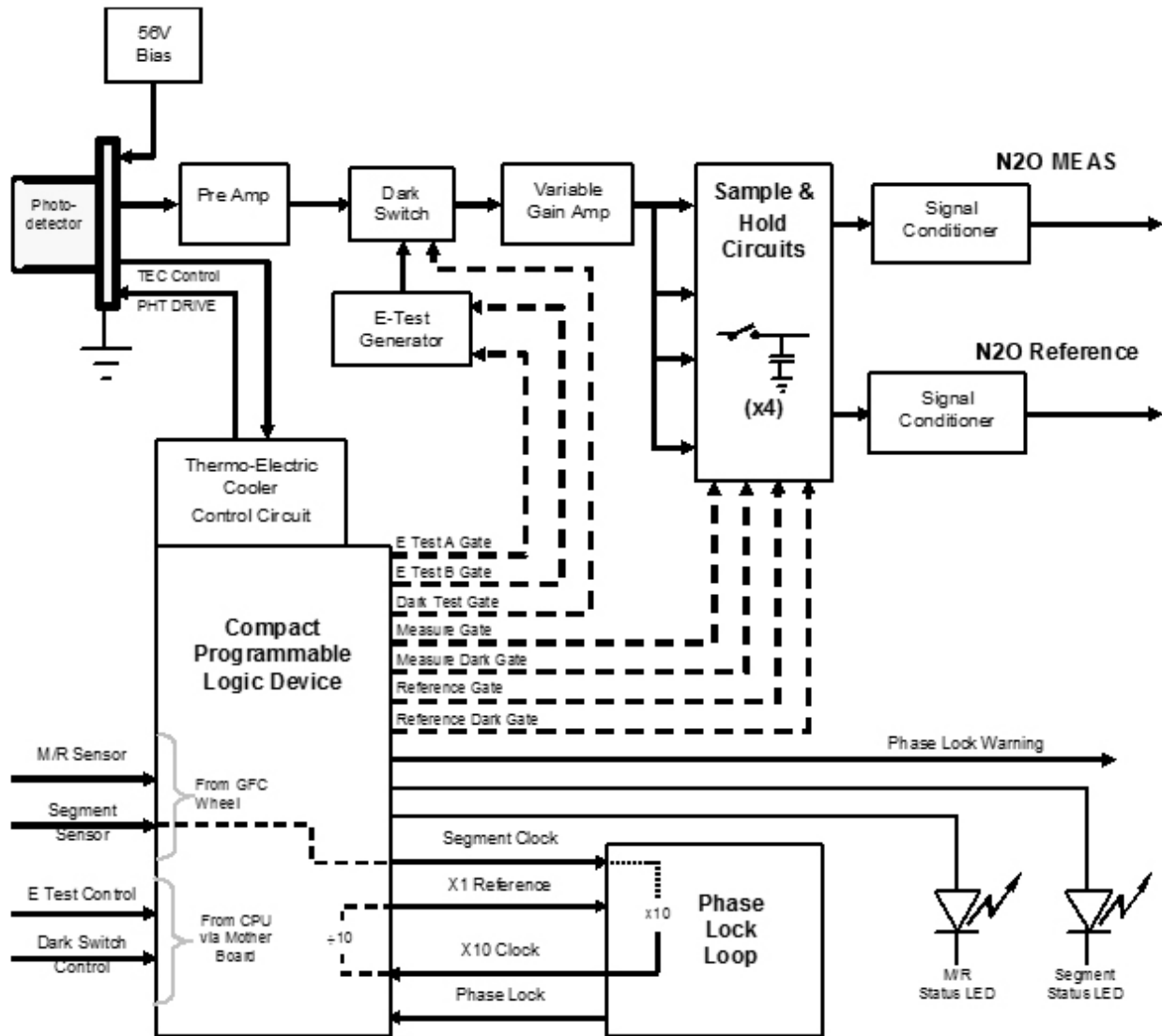

Figure 12-13: GFC7002T/GFC7002TU Sync/Demod Block Diagram

12.4.3.1. SIGNAL SYNCHRONIZATION AND DEMODULATION

The signal emitted by the IR photo-detector goes through several stages of amplification before it can be accurately demodulated. The first is a pre-amplification stage that raises the signal to levels readable by the rest of the sync/demod board circuitry. The second is a variable amplification stage that is adjusted at the factory to compensate for performance variations of mirrors, detectors, and other components of the optical bench from instrument to instrument.

The workhorses of the sync/demod board are the four sample-and-hold circuits that capture various voltage levels found in the amplified detector signal needed to determine the value of **N2O MEAS** and **N2O REF**. They are activated by logic signals under the control of a compact Programmable Logic Device (PLD), which in turn responds to the output of the Segment Sensor and M/R Sensor as shown in Figure 12-9.

The four sample and hold circuits are designated as follows:

Table 12-2: Sync DEMOD Sample and Hold Circuits

Designation	Active When:	
	IR BEAM PASSING THROUGH	Segment Sensor Pulse is:
Measure Gate	MEASUREMENT cell of GFC Wheel	HIGH
Measure Dark Gate	MEASUREMENT Cell of GFC Wheel	LOW
Reference Gate	REFERENCE cell of GFC Wheel	HIGH
Reference Dark Gate	REFERENCE cell of GFC Wheel	LOW

Timing for activating the Sample and Hold Circuits is provided by a Phase Lock Loop (PLL) circuit. Using the segment sensor output as a reference signal the PLL generates clock signal at ten times that frequency. This faster clock signal is used by the PLD to make the Sample and Hold Circuits capture the signal during the center portions of the detected waveform, ignore the rising and falling edges of the detector signal.

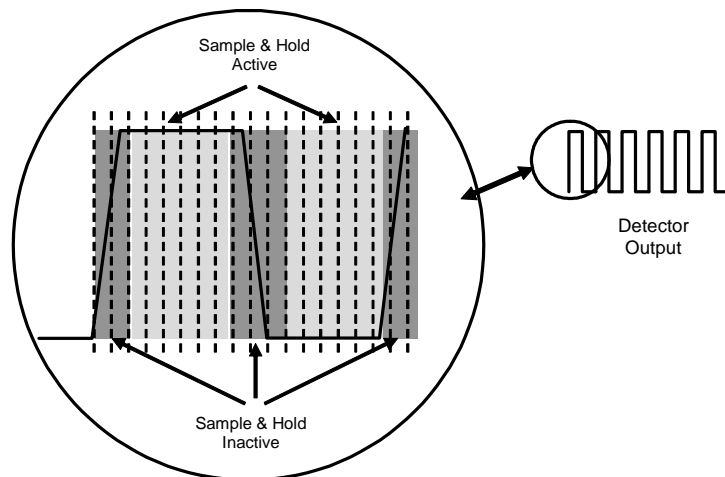

Figure 12-14: Sample & Hold Timing

12.4.3.2. SYNC/DEMOD STATUS LEDES

The following two status LEDs located on the sync/demod board provide additional diagnostic tools for checking the GFC Wheel rotation.

Table 12-3: Sync/Demod Status LED Activity

LED	Function	Status OK	Fault Status
D1	M/R Sensor Status	LED flashes approximately 2/second	LED is stuck ON or OFF
D2	Segment Sensor Status	LED flashes approximately 6/second	LED is stuck ON or OFF

See Section 11.1.4.2 for more information.

12.4.3.3. PHOTO-DETECTOR TEMPERATURE CONTROL

The sync/demod board also contains circuitry that controls the IR photo-detector's Thermal Electric Coolers (TEC). A drive voltage, **PHT DRIVE**, is supplied to the

coolers by the sync/demod board which is adjusted by the sync/demod board based on a return signal called TEC control which alerts the sync/demod board of the detector's temperature. The warmer the detector, the harder the coolers are driven.

PHT DRIVE is one of the Test Functions viewable by the user via the form panel. Press <TST or TST> until it appears on the display.

12.4.3.4. DARK CALIBRATION SWITCH

This switch initiates the Dark Calibration procedure. When initiated by the user (See Section 9.5.1 for more details), the dark calibration process opens this switch, interrupting the signal from the IR photo-detector. This allows the analyzer to measure any offset caused by the sync/demod board circuitry.

12.4.3.5. ELECTRIC TEST SWITCH

When active, this circuit generates a specific waveform intended to simulate the function of the IR photo-detector but with a known set of value which is substituted for the detector's actual signal via the dark switch. It may also be initiated by the user (See Section 5.4 for more details).

12.4.4. RELAY BOARD

By actuating various switches and relays located on this board, the CPU controls the status of other key components. The relay board receives instructions in the form of digital signals over the I²C bus, interprets these digital instructions and activates its various switches and relays appropriately.

12.4.4.1. HEATER CONTROL

The two heaters attached to the sample chamber housing and the GFC Wheel motor are controlled by solid state relays located on the relay board.

The GFC Wheel heater is simply turned on or off, however control of the bench heater also includes circuitry that selects which one of its two separate heating elements is activated depending on whether the instrument is running on 100 VAC, 115 VAC or 230 VAC line power.

12.4.4.2. GFC WHEEL MOTOR CONTROL

The GFC Wheel operates from a AC voltage supplied by a multi-input transformer located on the relay board. The step-down ratio of this transformer is controlled by factory-installed jumpers to adjust for 100 VAC, 115 VAC or 230 VAC line power. Other circuitry slightly alters the phase of the AC power supplied to the motor during start up based on whether line power is 50Hz or 60 Hz.

Normally, the GFC Wheel Motor is always turning while the analyzer is on. A physical switch located on the relay board can be used to turn the motor off for certain diagnostic procedures.

12.4.4.3. ZERO/SPAN VALVE OPTIONS

Any zero/span/shutoff valve options installed in the analyzer are controlled by a set of electronic switches located on the relay board. These switches, under CPU control, supply the +12VDC needed to activate each valve's solenoid.

12.4.4.4. IR SOURCE

The relay board supplies a constant 11.5VDC to the IR Source. Under normal operation the IR source is always on.

12.4.4.5. STATUS LEDS

Eight LEDs are located on the analyzer's relay board to show the current status on the various control functions performed by the relay board. They are listed on Table 12-4.

Table 12-4: Relay Board Status LEDS

LED	COLOR	FUNCTION	STATUS WHEN LIT	STATUS WHEN UNLIT
D1	RED	Watch Dog Circuit	Cycles On/Off every 3 seconds under direct control of the analyzer's CPU.	
D2	YELLOW	Wheel Heater	HEATING	NOT HEATING
D3	YELLOW	Bench Heater	HEATING	NOT HEATING
D4	YELLOW	Spare	N/A	N/A
D5	GREEN	Sample/Cal Gas Valve Option	Valve Open to CAL GAS FLOW	Valve Open to SAMPLE Gas Flow
D6	GREEN	Zero/Span Gas Valve Option	Valve Open to SPAN GAS FLOW	Valve Open to ZERO GAS FLOW
D7	GREEN	Shutoff Valve Option	Valve Open to CAL GAS FLOW	Valve CLOSED to CAL GAS FLOW
D8	GREEN	IR SOURCE	Source ON	Source OFF

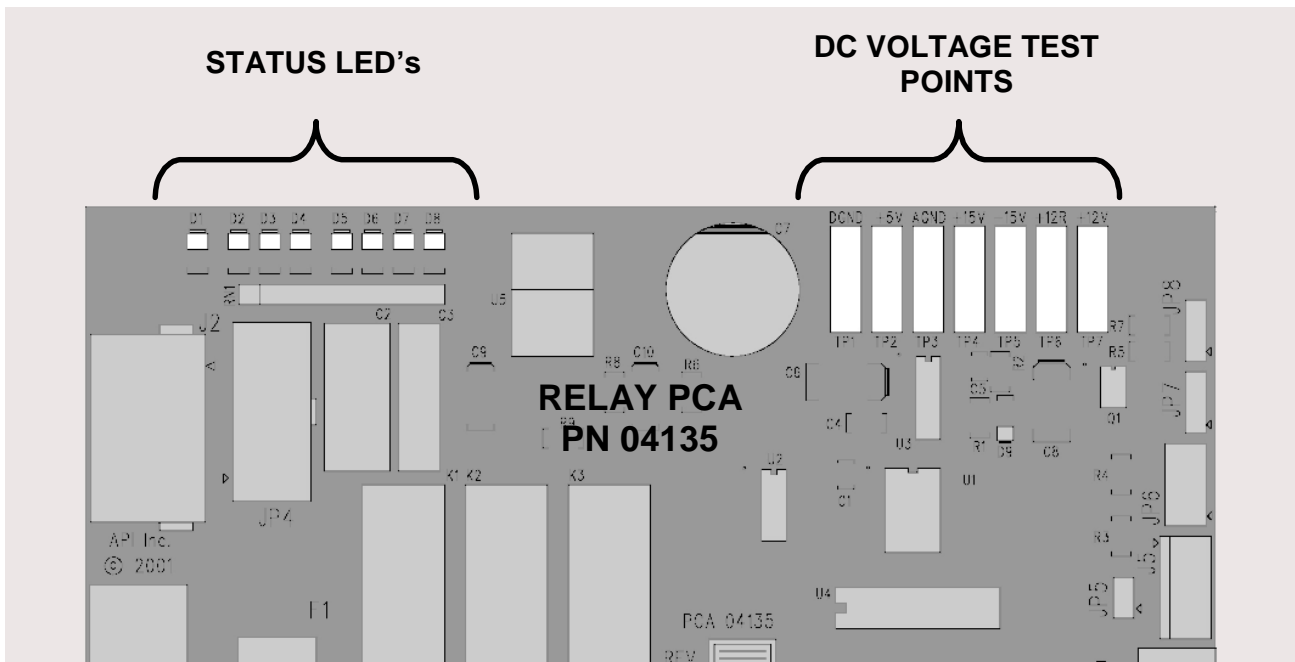

Figure 12-15: Location of relay board Status LEDs

12.4.4.6. I2C WATCH DOG CIRCUITRY

Special circuitry on the relay board monitors the activity on the I²C bus and drives LED D1. Should this LED ever stay ON or OFF for 30 seconds, the watch dog circuit will automatically shut off all valves as well as turn off the IR Source and all heaters. The GFC Wheel motor will still be running since it is not controlled by the relay board.

12.4.5. MOTHERBOARD

This printed circuit assembly provides a multitude of functions including, A/D conversion, digital input/output, PC-104 to I²C translation, temperature sensor signal processing and is a pass through for the RS-232 and RS-485 signals.

12.4.5.1. A TO D CONVERSION

Analog signals, such as the voltages received from the analyzer's various sensors, are converted into digital signals that the CPU can understand and manipulate by the analog to digital converter (A/D). Under the control of the CPU, this functional block selects a particular signal input (e.g. BOX TEMP, N2O MEAS, N2O REF, etc.) and then converts the selected voltage into a digital word.

The A/D consists of a Voltage-to-Frequency (V-F) converter, a Programmable Logic Device (PLD), three multiplexers, several amplifiers and some other associated devices. The V-F converter produces a frequency proportional to its input voltage. The PLD counts the output of the V-F during a specified time period, and sends the result of that count, in the form of a binary number, to the CPU.

The A/D can be configured for several different input modes and ranges but in the GFC7002T/GFC7002TU is used in uni-polar mode with a +5 V full scale. The converter includes a 1% over and under-range. This allows signals from -0.05 V to +5.05 V to be fully converted.

For calibration purposes, two reference voltages are supplied to the A/D converter: Reference Ground and +4.096 VDC. During calibration, the device measures these two voltages, outputs their digital equivalent to the CPU. The CPU uses these values to compute the converter's offset and slope and uses these factors for subsequent conversions.

See Section 5.8.3.1 for instructions on performing this calibration.

12.4.5.2. SENSOR INPUTS

The key analog sensor signals are coupled to the A/D through the master multiplexer from two connectors on the motherboard. 100K terminating resistors on each of the inputs prevent cross talk from appearing on the sensor signals.

N₂O MEASURE AND REFERENCE

These are the primary signals that are used in the computation of the N₂O concentration. They are the demodulated IR-sensor signals from the sync demodulator board.

SAMPLE PRESSURE AND FLOW

These are analog signals from two sensors that measure the pressure and flow rate of the gas stream at the outlet of the sample chamber. This information is used in two ways. First, the sample pressure is used by the CPU to calculate N₂O concentration. Second, the pressure and flow rate are monitored as a test function to assist the user in predicting and troubleshooting failures.

12.4.5.3. THERMISTOR INTERFACE

This circuit provides excitation, termination and signal selection for several negative-coefficient, thermistor temperature sensors located inside the analyzer. They are as follows:

SAMPLE TEMPERATURE SENSOR

The source of this signal is a thermistor located inside the sample chamber of the Optical Bench. It measures the temperature of the sample gas in the chamber. This data is used to during the calculation of the N₂O concentration value.

BENCH TEMPERATURE SENSOR

This thermistor is attached to the sample chamber housing. It reports the current temperature of the chamber housing to the CPU as part of the bench heater control loop.

WHEEL TEMPERATURE SENSOR

This thermistor is attached to the heatsink on the GFC Wheel motor assembly. It reports the current temperature of the wheel/motor assembly to the CPU as part of the Wheel Heater control loop.

BOX TEMPERATURE SENSOR

A thermistor is attached to the motherboard. It measures the analyzer's internal temperature. This information is stored by the CPU and can be viewed by the user for troubleshooting purposes via the front panel display (see Section 11.1.2).

12.4.5.4. ANALOG OUTPUTS

The analyzer comes equipped with four analog outputs: **A1**, **A2**, **A3** and **A4**. The type of data and electronic performance of these outputs are configurable by the user (see Section 5.4).

OUTPUT LOOP-BACK

All four analog outputs are connected back to the A/D converter through a loop-back circuit. This permits the voltage outputs to be calibrated by the CPU without need for any additional tools or fixtures.

12.4.5.5. INTERNAL DIGITAL I/O

This channel is used to communicate digital status and control signals about the operation of key components of the Optical Bench. The CPU sends signals to the sync/demod board that initiate the **ELECTRICAL TEST** and **DARK CALIBRATION** procedures.

12.4.5.6. EXTERNAL DIGITAL I/O

This External Digital I/O performs two functions: status outputs and control inputs.

STATUS OUTPUTS

Logic-Level voltages are output through an optically isolated 8-pin connector located on the rear panel of the analyzer. These outputs convey good/bad and on/off information about certain analyzer conditions. They can be used to interface with certain types of programmable devices (See Section 3.3.1.4).

CONTROL INPUTS

By applying +5VDC power supplied from an external source such as a PLC or Data logger (See Section 3.3.1.6), Zero and Span calibrations can be initiated by contact closures on the rear panel.

POWER UP CIRCUIT

This circuit monitors the +5V power supply during start-up and sets the analog outputs, external digital I/O ports, and I²C circuitry to specific values until the CPU boots and the instrument software can establish control.

12.4.6. I²C DATA BUS

I²C is a two-wire, clocked, bi-directional, digital serial I/O bus that is used widely in commercial and consumer electronic systems. A transceiver on the motherboard converts data and control signals from the PC-104 bus to I²C. The data is then fed to the relay board, optional analog input board and valve driver board circuitry.

12.4.7. POWER SUPPLY/ CIRCUIT BREAKER

The analyzer operates on 100 VAC, 115 VAC or 230 VAC power at either 50Hz or 60Hz. Individual units are set up at the factory to accept any combination of these five attributes. As illustrated in Figure 12-14, power enters the analyzer through a standard IEC 320 power receptacle located on the rear panel of the instrument. From there it is routed through the ON/OFF Switch located in the lower right corner of the Front Panel. A 6.75 Amp circuit breaker is built into the ON/OFF Switch.

The bench and GFC Wheel heaters as well as the GFC Wheel receive AC power via the relay board.

AC Line power is converted stepped down and converted to DC power by two DC power supplies. One supplies +12 VDC, for valves and the IR source, while a second supply provides +5 VDC and ± 15 VDC for logic and analog circuitry. All DC voltages are distributed via the relay board.



CAUTION

GENERAL SAFETY HAZARD

Should the AC power circuit breaker trip, investigate and correct the condition causing this situation before turning the analyzer back on.

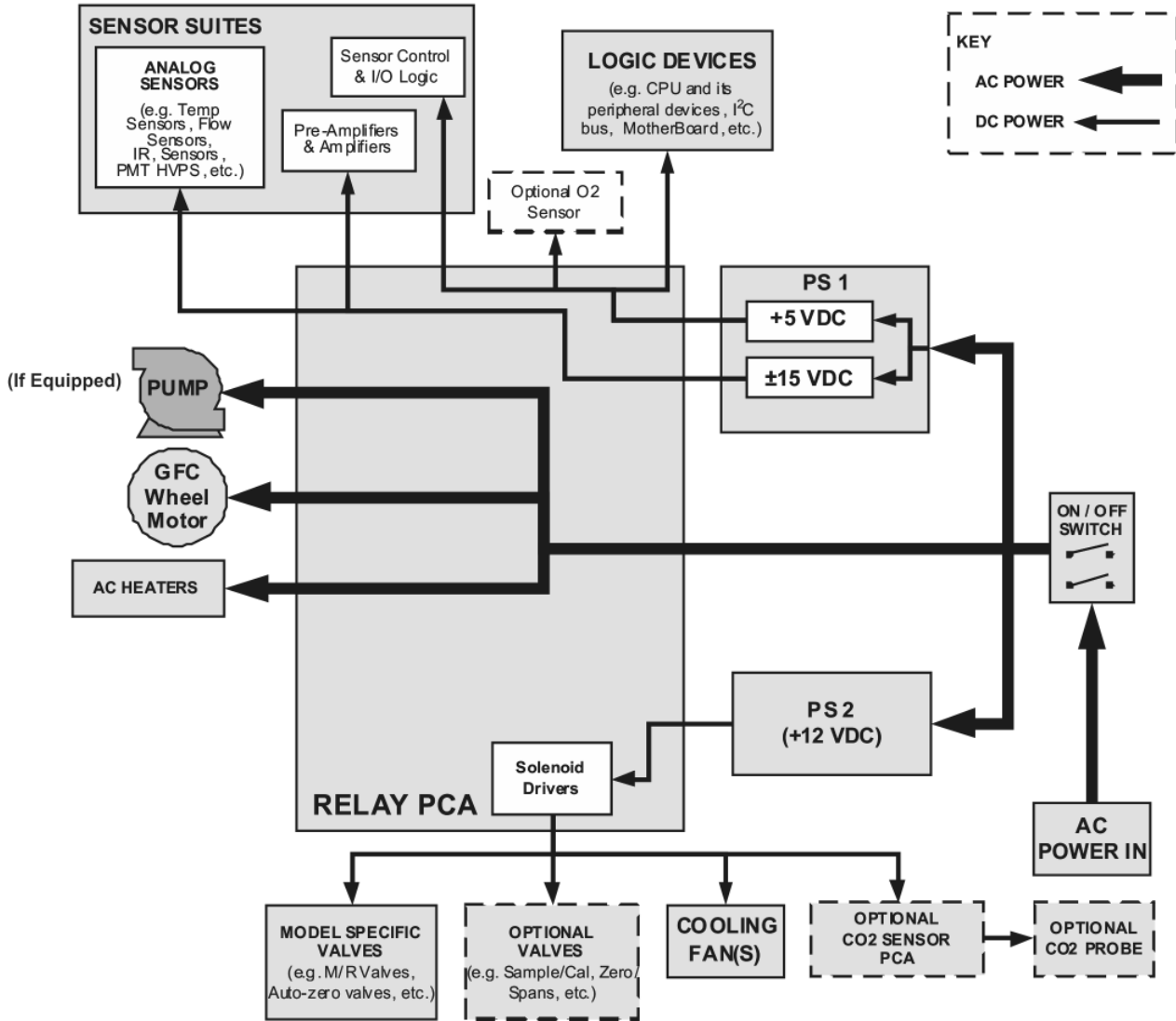

Figure 12-16: Power Distribution Block Diagram

12.4.8. FRONT PANEL TOUCHSCREEN/DISPLAY INTERFACE

Users can input data and receive information directly through the front panel touchscreen display. The LCD display is controlled directly by the CPU board. The touchscreen is interfaced to the CPU by means of a touchscreen controller that connects to the CPU via the internal USB bus and emulates a computer mouse.

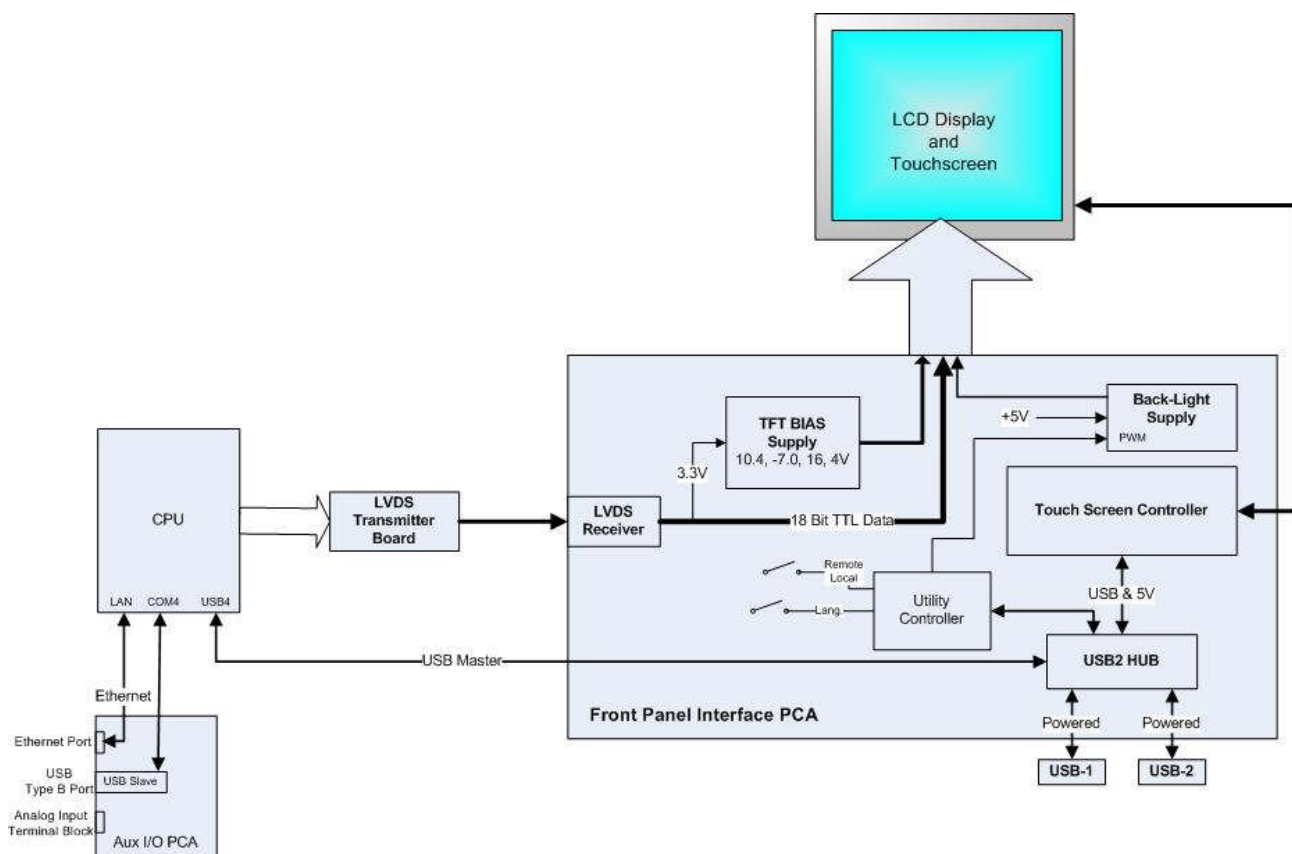

Figure 12-17: Front Panel and Display Interface Block Diagram

12.4.8.1. LVDS TRANSMITTER BOARD

The LVDS (low voltage differential signaling) transmitter board converts the parallel display bus to a serialized, low voltage, differential signal bus in order to transmit the video signal to the LCD interface PCA.

12.4.8.2. FRONT PANEL TOUCHSCREEN/DISPLAY INTERFACE PCA

The front panel touchscreen/display interface PCA controls the various functions of the display and touchscreen. For driving the display it provides connection between the CPU video controller and the LCD display module. This PCA also contains:

- Power supply circuitry for the LCD display module.
- A USB hub that is used for communications with the touchscreen controller and the two front panel USB device ports.
- The circuitry for powering the display backlight.

12.5. SOFTWARE OPERATION

The GFC7002T/GFC7002TU Gas Filter Correlation Carbon Monoxide Analyzer has a high performance, VortexX86-based microcomputer running Windows CE. Inside Windows CE, special software developed by TAI interprets user commands via the various interfaces, performs procedures and tasks, stores data in the CPU's various memory devices and calculates the concentration of the sample gas.

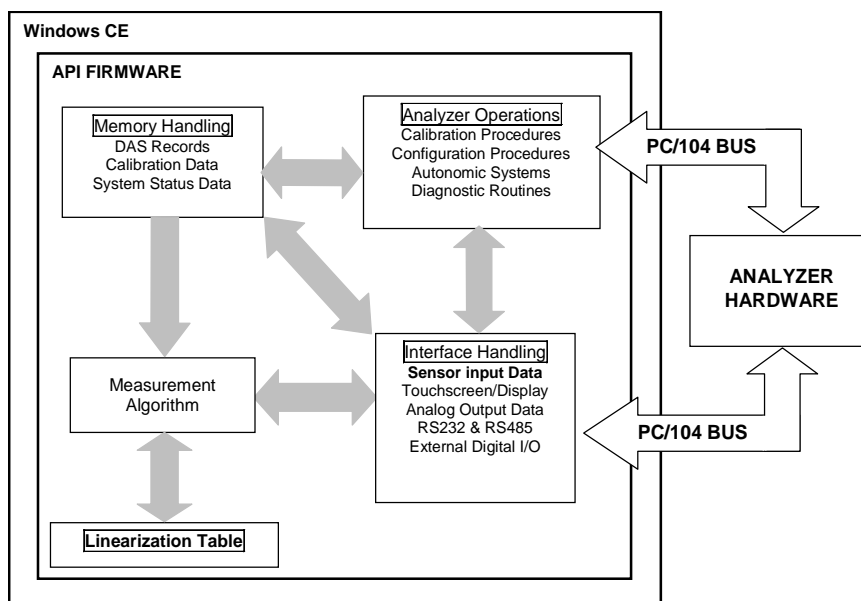

Figure 12-18: Basic Software Operation

12.5.1. ADAPTIVE FILTER

The GFC7002T/GFC7002TU software processes the **N2O MEAS** and **N2O REF** signals, after they are digitized by the motherboard, through an adaptive filter built into the software. Unlike other analyzers that average the output signal over a fixed time period, the GFC7002T/GFC7002TU averages over a set number of samples, where each sample is 0.2 seconds. This technique is known as boxcar averaging. During operation, the software automatically switches between two different length filters based on the conditions at hand. Once triggered, the short filter remains engaged for a fixed time period to prevent chattering.

During conditions of constant or nearly constant concentration the software, by default, computes an average of the last 750 samples, or approximately 150 seconds. This provides the calculation portion of the software with smooth stable readings. If a rapid change in concentration is detected the filter includes, by default, the last 48 samples, approximately 10 seconds of data, to allow the analyzer to more quickly respond. If necessary, these boxcar lengths can be changed between 1 and 1000 samples but with corresponding tradeoffs in rise time and signal-to-noise ratio (contact customer service for more information).

Two conditions must be simultaneously met to switch to the short filter. First the instantaneous concentration must exceed the average in the long filter by a fixed amount. Second the instantaneous concentration must exceed the average in the long filter by a portion, or percentage, of the average in the long filter.

12.5.2. CALIBRATION - SLOPE AND OFFSET

Calibration of the analyzer is performed exclusively in software.

During instrument calibration (see Section 9) the user enters expected values for zero and span via the front panel control buttons and commands the instrument to make readings of calibrated sample gases for both levels. The readings taken are adjusted, linearized, and compared to the expected values. With this information the software computes values for instrument slope and offset and stores these values in memory for use in calculating the N₂O concentration of the sample gas.

The instrument slope and offset values recorded during the last calibration are available for viewing from the front panel (see Section 3.4.3).

12.5.3. MEASUREMENT ALGORITHM

Once the IR photo-detector signal is demodulated into **N₂O MEAS** and **N₂O REF** by the sync/demod board and converted to digital data by the motherboard, the GFC7002T/GFC7002TU analytical software calculates the ratio between **N₂O MEAS** and **N₂O REF**. This value is compared to a look-up table that is used, with interpolation, to linearize the response of the instrument. The linearized concentration value is combined with calibration slope and offset values, then normalized for changes in sample gas pressure to produce the final N₂O concentration. This is the value that is displayed on the instrument front panel display and is stored in memory by the analyzer's DAS system.

12.5.4. TEMPERATURE AND PRESSURE COMPENSATION

Changes in pressure can have a noticeable effect on the N₂O concentration calculation. To account for this, the GFC7002T/GFC7002TU software includes a feature which allows the instrument to compensate for the N₂O calculations based on changes in ambient pressure.

The TPC feature multiplies the analyzer's N₂O concentration by a factor which is based on the difference between the ambient pressure of the sample gas normalized to standard atmospheric pressure. As ambient pressure increases, the compensated N₂O concentration is decreased.

12.5.5. INTERNAL DATA ACQUISITION SYSTEM (DAS)

The DAS is designed to implement predictive diagnostics that stores trending data for users to anticipate when an instrument will require service. Large amounts of data can be stored in non-volatile memory and retrieved in plain text format for further processing with common data analysis programs. The DAS has a consistent user interface in all TAI analyzers. New data parameters and triggering events can be added to the instrument as needed.

Depending on the sampling frequency and the number of data parameters the DAS can store several months of data, which are retained even when the instrument is powered off or a new firmware is installed. The DAS permits users to access the data through the instrument's front panel or the remote interface. The latter can automatically download stored data for further processing. For information on using the DAS, refer to Section 7.

13. A PRIMER ON ELECTRO-STATIC DISCHARGE

TAI considers the prevention of damage caused by the discharge of static electricity to be extremely important part of making sure that your analyzer continues to provide reliable service for a long time. This section describes how static electricity occurs, why it is so dangerous to electronic components and assemblies as well as how to prevent that damage from occurring.

13.1. HOW STATIC CHARGES ARE CREATED

Modern electronic devices such as the types used in the various electronic assemblies of your analyzer, are very small, require very little power and operate very quickly. Unfortunately, the same characteristics that allow them to do these things also make them very susceptible to damage from the discharge of static electricity. Controlling electrostatic discharge begins with understanding how electro-static charges occur in the first place.

Static electricity is the result of something called triboelectric charging which happens whenever the atoms of the surface layers of two materials rub against each other. As the atoms of the two surfaces move together and separate, some electrons from one surface are retained by the other.

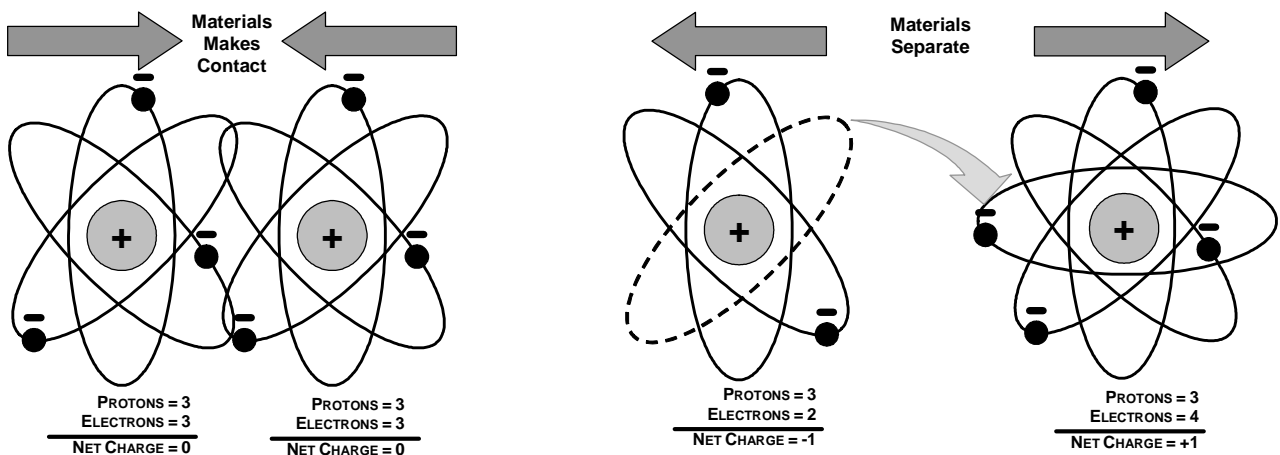

Figure 13-1: Triboelectric Charging

If one of the surfaces is a poor conductor or even a good conductor that is not grounded, the resulting positive or negative charge cannot bleed off and becomes trapped in place, or static. The most common example of triboelectric charging happens when someone

wearing leather or rubber soled shoes walks across a nylon carpet or linoleum tiled floor. With each step, electrons change places and the resulting electro-static charge builds up, quickly reaching significant levels. Pushing an epoxy printed circuit board across a workbench, using a plastic handled screwdriver or even the constant jostling of Styrofoam™ pellets during shipment can also build hefty static charges.

Table 13-1: Static Generation Voltages for Typical Activities

MEANS OF GENERATION	65-90% RH	10-25% RH
Walking across nylon carpet	1,500V	35,000V
Walking across vinyl tile	250V	12,000V
Worker at bench	100V	6,000V
Poly bag picked up from bench	1,200V	20,000V
Moving around in a chair padded with urethane foam	1,500V	18,000V

13.2. HOW ELECTRO-STATIC CHARGES CAUSE DAMAGE

Damage to components occurs when these static charges come into contact with an electronic device. Current flows as the charge moves along the conductive circuitry of the device and the typically very high voltage levels of the charge overheat the delicate traces of the integrated circuits, melting them or even vaporizing parts of them. When examined by microscope the damage caused by electro-static discharge looks a lot like tiny bomb craters littered across the landscape of the component's circuitry.

A quick comparison of the values in Table 13-1 with the those shown in the Table 13-2, listing device susceptibility levels, shows why *Semiconductor Reliability News* estimates that approximately 60% of device failures are the result of damage due to electro-static discharge.

Table 13-2: Sensitivity of Electronic Devices to Damage by ESD

DEVICE	DAMAGE SUSCEPTIBILITY VOLTAGE RANGE	
	DAMAGE BEGINS OCCURRING AT	CATASTROPHIC DAMAGE AT
MOSFET	10	100
VMOS	30	1800
NMOS	60	100
GaAsFET	60	2000
EPROM	100	100
JFET	140	7000
SAW	150	500
Op-AMP	190	2500
CMOS	200	3000
Schottky Diodes	300	2500
Film Resistors	300	3000
This Film Resistors	300	7000
ECL	500	500
SCR	500	1000
Schottky TTL	500	2500

Potentially damaging electro-static discharges can occur:

- Any time a charged surface (including the human body) discharges to a device. Even simple contact of a finger to the leads of a sensitive device or assembly can allow enough discharge to cause damage. A similar discharge can occur from a charged conductive object, such as a metallic tool or fixture.
- When static charges accumulated on a sensitive device discharges from the device to another surface such as packaging materials, work surfaces, machine surfaces or other device. In some cases, charged device discharges can be the most destructive.
- A typical example of this is the simple act of installing an electronic assembly into the connector or wiring harness of the equipment in which it is to function. If the assembly is carrying a static charge, as it is connected to ground a discharge will occur.
- Whenever a sensitive device is moved into the field of an existing electro-static field, a charge may be induced on the device in effect discharging the field onto the device. If the device is then momentarily grounded while within the electrostatic field or removed from the region of the electrostatic field and grounded somewhere else, a second discharge will occur as the charge is transferred from the device to ground.

13.3. COMMON MYTHS ABOUT ESD DAMAGE

- **I didn't feel a shock so there was no electro-static discharge:** The human nervous system isn't able to feel a static discharge of less than 3500 volts. Most devices are damaged by discharge levels much lower than that.
- **I didn't touch it so there was no electro-static discharge:** Electro Static charges are fields whose lines of force can extend several inches or sometimes even feet away from the surface bearing the charge.
- **It still works so there was no damage:** Sometimes the damage caused by electro-static discharge can completely sever a circuit trace causing the device to fail immediately. More likely, the trace will be only partially occluded by the damage causing degraded performance of the device or worse, weakening the trace. This weakened circuit may seem to function fine for a short time, but even the very low voltage and current levels of the device's normal operating levels will eat away at the defect over time causing the device to fail well before its designed lifetime is reached.
- These latent failures are often the most costly since the failure of the equipment in which the damaged device is installed causes down time, lost data, lost productivity, as well as possible failure and damage to other pieces of equipment or property.
- **Static Charges can't build up on a conductive surface:** There are two errors in this statement.
- **Conductive devices can build static charges if they are not grounded.** The charge will be equalized across the entire device, but without access to earth ground, they are still trapped and can still build to high enough levels to cause damage when they are discharged.
- **A charge can be induced onto the conductive surface and/or discharge triggered in the presence of a charged field such as a large static charge clinging to the surface of a nylon jacket of someone walking up to a workbench.**

- **As long as my analyzer is properly installed, it is safe from damage caused by static discharges:** It is true that when properly installed the chassis ground of your analyzer is tied to earth ground and its electronic components are prevented from building static electric charges themselves. This does not prevent discharges from static fields built up on other things, like you and your clothing, from discharging through the instrument and damaging it.

13.4. BASIC PRINCIPLES OF STATIC CONTROL

It is impossible to stop the creation of instantaneous static electric charges. It is not, however difficult to prevent those charges from building to dangerous levels or prevent damage due to electro-static discharge from occurring.

13.4.1. GENERAL RULES

Only handle or work on all electronic assemblies at a properly set up ESD station. Setting up an ESD safe workstation need not be complicated. A protective mat properly tied to ground and a wrist strap are all that is needed to create a basic anti-ESD workstation.

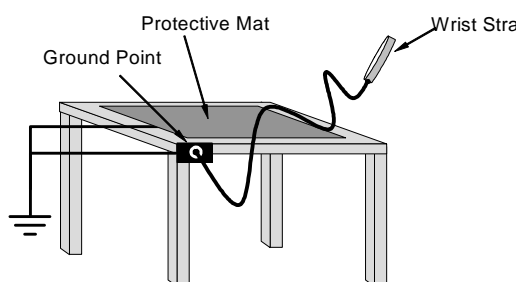

Figure 13-2: Basic anti-ESD Workbench

For technicians that work in the field, special lightweight and portable anti-ESD kits are available from most suppliers of ESD protection gear. These include everything needed to create a temporary anti-ESD work area anywhere.

- **Always wear an Anti-ESD wrist strap when working on the electronic assemblies of your analyzer.** An anti-ESD wrist strap keeps the person wearing it at or near the same potential as other grounded objects in the work area and allows static charges to dissipate before they can build to dangerous levels. Anti-ESD wrist straps terminated with alligator clips are available for use in work areas where there is no available grounded plug.
- Also, anti-ESD wrist straps include a current limiting resistor (usually around one meg-ohm) that protects you should you accidentally short yourself to the instrument's power supply.
- **Simply touching a grounded piece of metal is insufficient.** While this may temporarily bleed off static charges present at the time, once you stop touching the grounded metal new static charges will immediately begin to re-build. In some conditions, a charge large enough to damage a component can rebuild in just a few seconds.
- **Always store sensitive components and assemblies in anti-ESD storage bags or bins:** Even when you are not working on them, store all devices and assemblies in a closed anti-Static bag or bin. This will prevent induced charges

from building up on the device or assembly and nearby static fields from discharging through it.

- **Use metallic anti-ESD bags for storing and shipping ESD sensitive components and assemblies rather than pink-poly bags.** The famous, pink-poly bags are made of a plastic that is impregnated with a liquid (similar to liquid laundry detergent) which very slowly sweats onto the surface of the plastic creating a slightly conductive layer over the surface of the bag.
- While this layer may equalize any charges that occur across the whole bag, it does not prevent the build up of static charges. If laying on a conductive, grounded surface, these bags will allow charges to bleed away but the very charges that build up on the surface of the bag itself can be transferred through the bag by induction onto the circuits of your ESD sensitive device. Also, the liquid impregnating the plastic is eventually used up after which the bag is as useless for preventing damage from ESD as any ordinary plastic bag.
- Anti-Static bags made of plastic impregnated with metal (usually silvery in color) provide all of the charge equalizing abilities of the pink-poly bags but also, when properly sealed, create a Faraday cage that completely isolates the contents from discharges and the inductive transfer of static charges.
- Storage bins made of plastic impregnated with carbon (usually black in color) are also excellent at dissipating static charges and isolating their contents from field effects and discharges.
- **Never use ordinary plastic adhesive tape near an ESD sensitive device or to close an anti-ESD bag.** The act of pulling a piece of standard plastic adhesive tape, such as Scotch[®] tape, from its roll will generate a static charge of several thousand or even tens of thousands of volts on the tape itself and an associated field effect that can discharge through or be induced upon items up to a foot away.

13.4.2. BASIC ANTI-ESD PROCEDURES FOR ANALYZER REPAIR AND MAINTENANCE

13.4.2.1. WORKING AT THE INSTRUMENT RACK

When working on the analyzer while it is in the instrument rack and plugged into a properly grounded power supply:

1. Attach you anti-ESD wrist strap to ground before doing anything else.
 - Use a wrist strap terminated with an alligator clip and attach it to a bare metal portion of the instrument chassis.
 - This will safely connect you to the same ground level to which the instrument and all of its components are connected.
2. Pause for a second or two to allow any static charges to bleed away.
3. Open the casing of the analyzer and begin work. Up to this point, the closed metal casing of your analyzer has isolated the components and assemblies inside from any conducted or induced static charges.
4. If you must remove a component from the instrument, do not lay it down on a non-ESD preventative surface where static charges may lie in wait.
5. Only disconnect your wrist strap after you have finished work and closed the case of the analyzer.

13.4.2.2. WORKING AT AN ANTI-ESD WORK BENCH

When working on an instrument of an electronic assembly while it is resting on a anti-ESD workbench:

1. Plug you anti-ESD wrist strap into the grounded receptacle of the work station before touching any items on the work station and while standing at least a foot or so away. This will allow any charges you are carrying to bleed away through the ground connection of the workstation and prevent discharges due to field effects and induction from occurring.
2. Pause for a second or two to allow any static charges to bleed away.
3. Only open any anti-ESD storage bins or bags containing sensitive devices or assemblies after you have plugged your wrist strap into the workstation.
 - Lay the bag or bin on the workbench surface.
 - Before opening the container, wait several seconds for any static charges on the outside surface of the container to be bled away by the workstation's grounded protective mat.
4. Do not pick up tools that may be carrying static charges while also touching or holding an ESD sensitive device.
 - Only lay tools or ESD-sensitive devices and assemblies on the conductive surface of your workstation. Never lay them down on any non-ESD preventative surface.
5. Place any static sensitive devices or assemblies in anti-static storage bags or bins and close the bag or bin before unplugging your wrist strap.
6. Disconnecting your wrist strap is always the last action taken before leaving the workbench.

13.4.2.3. TRANSFERRING COMPONENTS FROM RACK TO BENCH AND BACK

When transferring a sensitive device from an installed TAI analyzer to an anti-ESD workbench or back:

1. Follow the instructions listed above for working at the instrument rack and workstation.
2. Never carry the component or assembly without placing it in an anti-ESD bag or bin.
3. Before using the bag or container allow any surface charges on it to dissipate:
 - If you are at the instrument rack, hold the bag in one hand while your wrist strap is connected to a ground point.
 - If you are at an anti-ESD workbench, lay the container down on the conductive work surface.
 - In either case wait several seconds.
4. Place the item in the container.
5. Seal the container. If using a bag, fold the end over and fastening it with anti-ESD tape.
 - Folding the open end over isolates the component(s) inside from the effects of static fields.

- Leaving the bag open or simply stapling it shut without folding it closed prevents the bag from forming a complete protective envelope around the device.
6. Once you have arrived at your destination, allow any surface charges that may have built up on the bag or bin during travel to dissipate:
 - Connect your wrist strap to ground.
 - If you are at the instrument rack, hold the bag in one hand while your wrist strap is connected to a ground point.
 - If you are at a anti-ESD workbench, lay the container down on the conductive work surface
 - In either case wait several seconds
 7. Open the container.

13.4.2.4. OPENING SHIPMENTS FROM TELEDYNE CUSTOMER SERVICE

Packing materials such as bubble pack and Styrofoam pellets are extremely efficient generators of static electric charges. To prevent damage from ESD, Teledyne ships all electronic components and assemblies in properly sealed anti-ESD containers.

Static charges will build up on the outer surface of the anti-ESD container during shipping as the packing materials vibrate and rub against each other. To prevent these static charges from damaging the components or assemblies being shipped make sure that you:

Always unpack shipments from TAI Customer Service by:

1. Opening the outer shipping box away from the anti-ESD work area.
2. Carry the still sealed anti-ESD bag, tube or bin to the anti-ESD work area.
3. Follow steps 6 and 7 of Section 13.4.2.3 above when opening the anti-ESD container at the work station.
4. Reserve the anti-ESD container or bag to use when packing electronic components or assemblies to be returned to TAI.

13.4.2.5. PACKING COMPONENTS FOR RETURN TO TELEDYNE CUSTOMER SERVICE

Always pack electronic components and assemblies to be sent to Teledyne Customer Service in anti-ESD bins, tubes or bags.



CAUTION ESD Hazard

- **DO NOT** use pink-poly bags.
- **NEVER** allow any standard plastic packaging materials to touch the electronic component/assembly directly.
 - This includes, but is not limited to, plastic bubble-pack, Styrofoam peanuts, open cell foam, closed cell foam, and adhesive tape.
- **DO NOT** use standard adhesive tape as a sealer. Use **ONLY** anti-ESD tape.

Never carry the component or assembly without placing it in an anti-ESD bag or bin.

1. Before using the bag or container allow any surface charges on it to dissipate:
 - If you are at the instrument rack, hold the bag in one hand while your wrist strap is connected to a ground point.
 - If you are at an anti-ESD workbench, lay the container down on the conductive work surface.
 - In either case wait several seconds.
2. Place the item in the container.
3. Seal the container. If using a bag, fold the end over and fastening it with anti-ESD tape.
 - Folding the open end over isolates the component(s) inside from the effects of static fields.
 - Leaving the bag open or simply stapling it shut without folding it closed prevents the bag from forming a complete protective envelope around the device.

Note

If you do not already have an adequate supply of anti-ESD bags or containers available, Teledyne Customer Service department will supply them (see Section 11.8 for contact information).

Follow the instructions listed above for working at the instrument rack and workstation.

GLOSSARY

Note: Some terms in this glossary may not occur elsewhere in this manual.

Term	Description/Definition
10Base-T	an Ethernet standard that uses twisted ("T") pairs of copper wires to transmit at 10 megabits per second (Mbps)
100Base-T	same as 10BaseT except ten times faster (100 Mbps)
APICOM	name of a remote control program offered by Teledyne-API to its customers
ASSY	<i>Assembly</i>
CAS	<i>Code-Activated Switch</i>
CD	<i>Corona Discharge</i> , a frequently luminous discharge, at the surface of a conductor or between two conductors of the same transmission line, accompanied by ionization of the surrounding atmosphere and often by a power loss
CE	<i>Converter Efficiency</i> , the percentage of light energy that is actually converted into electricity
CEM	<i>Continuous Emission Monitoring</i>
Chemical formulas that may be included in this document:	
CO ₂	carbon dioxide
C ₃ H ₈	propane
CH ₄	methane
H ₂ O	water vapor
HC	general abbreviation for hydrocarbon
HNO ₃	nitric acid
H ₂ S	hydrogen sulfide
NO	nitric oxide
NO ₂	nitrogen dioxide
NO _x	nitrogen oxides, here defined as the sum of NO and NO ₂
NO _y	nitrogen oxides, often called odd nitrogen: the sum of NO _x plus other compounds such as HNO ₃ (definitions vary widely and may include nitrate (NO ₃), PAN, N ₂ O and other compounds as well)
N ₂ O	nitrous oxide
NH ₃	ammonia
O ₂	molecular oxygen
O ₃	ozone

SO ₂	sulfur dioxide
cm ³	metric abbreviation for <i>cubic centimeter</i> (replaces the obsolete abbreviation “cc”)
CPU	<i>Central Processing Unit</i>
DAC	<i>Digital-to-Analog Converter</i>
DAS	<i>Data Acquisition System</i>
DCE	<i>Data Communication Equipment</i>
DFU	<i>Dry Filter Unit</i>
DHCP	<i>Dynamic Host Configuration Protocol</i> . A protocol used by LAN or Internet servers to automatically set up the interface protocols between themselves and any other addressable device connected to the network
DIAG	<i>Diagnostics</i> , the diagnostic settings of the analyzer.
DOM	<i>Disk On Module</i> , a 44-pin IDE flash drive with up to 128MB storage capacity for instrument's firmware, configuration settings and data
DOS	<i>Disk Operating System</i>
DRAM	<i>Dynamic Random Access Memory</i>
DR-DOS	<i>Digital Research DOS</i>
DTE	<i>Data Terminal Equipment</i>
EEPROM	<i>Electrically Erasable Programmable Read-Only Memory</i> also referred to as a FLASH chip or drive
ESD	<i>Electro-Static Discharge</i>
ETEST	<i>Electrical Test</i>
Ethernet	a standardized (IEEE 802.3) computer networking technology for local area networks (LANs), facilitating communication and sharing resources
FEP	<i>Fluorinated Ethylene Propylene</i> polymer, one of the polymers that Du Pont markets as <i>Teflon</i> [®]
Flash	non-volatile, solid-state memory
FPI	<i>Fabry-Perot Interface</i> : a special light filter typically made of a transparent plate with two reflecting surfaces or two parallel, highly reflective mirrors
GFC	<i>Gas Filter Correlation</i>
I ² C bus	a clocked, bi-directional, serial bus for communication between individual analyzer components
IC	<i>Integrated Circuit</i> , a modern, semi-conductor circuit that can contain many basic components such as resistors, transistors, capacitors etc in a miniaturized

	package used in electronic assemblies
IP	<i>Internet Protocol</i>
IZS	<i>Internal Zero Span</i>
LAN	<i>Local Area Network</i>
LCD	<i>Liquid Crystal Display</i>
LED	<i>Light Emitting Diode</i>
LPM	<i>Liters Per Minute</i>
MFC	<i>Mass Flow Controller</i>
M/R	<i>Measure/Reference</i>
MOLAR MASS	<p>the mass, expressed in grams, of 1 mole of a specific substance. Conversely, one mole is the amount of the substance needed for the molar mass to be the same number in grams as the atomic mass of that substance.</p> <p>EXAMPLE: The atomic weight of Carbon is 12 therefore the molar mass of Carbon is 12 grams. Conversely, one mole of carbon equals the amount of carbon atoms that weighs 12 grams.</p> <p>Atomic weights can be found on any Periodic Table of Elements.</p>
NDIR	<i>Non-Dispersive Infrared</i>
NIST-SRM	<i>National Institute of Standards and Technology - Standard Reference Material</i>
PC	<i>Personal Computer</i>
PCA	<i>Printed Circuit Assembly, the PCB with electronic components, ready to use</i>
PC/AT	<i>Personal Computer / Advanced Technology</i>
PCB	<i>Printed Circuit Board, the bare board without electronic component</i>
PFA	<i>Perfluoroalkoxy, an inert polymer; one of the polymers that Du Pont markets as Teflon[®]</i>
PLC	<i>Programmable Logic Controller, a device that is used to control instruments based on a logic level signal coming from the analyzer</i>
PLD	<i>Programmable Logic Device</i>
PLL	<i>Phase Lock Loop</i>
PMT	<i>Photo Multiplier Tube, a vacuum tube of electrodes that multiply electrons collected and charged to create a detectable current signal</i>
P/N (or PN)	<i>Part Number</i>
PSD	<i>Prevention of Significant Deterioration</i>
PTFE	<i>Polytetrafluoroethylene, a very inert polymer material used to handle gases that may react on other surfaces; one of the polymers that Du Pont markets as Teflon[®]</i>

PVC	<i>Poly Vinyl Chloride</i> , a polymer used for downstream tubing
Rdg	Reading
RS-232	specification and standard describing a serial communication method between DTE (Data Terminal Equipment) and DCE (Data Circuit-terminating Equipment) devices, using a maximum cable-length of 50 feet
RS-485	specification and standard describing a binary serial communication method among multiple devices at a data rate faster than RS-232 with a much longer distance between the host and the furthest device
SAROAD	<i>Storage and Retrieval of Aerometric Data</i>
SLAMS	<i>State and Local Air Monitoring Network Plan</i>
SLPM	<i>Standard Liters Per Minute</i> of a gas at standard temperature and pressure
STP	<i>Standard Temperature and Pressure</i>
TCP/IP	<i>Transfer Control Protocol / Internet Protocol</i> , the standard communications protocol for Ethernet devices
TEC	<i>Thermal Electric Cooler</i>
TPC	<i>Temperature/Pressure Compensation</i>
USB	<i>Universal Serial Bus</i> : a standard connection method to establish communication between peripheral devices and a host controller, such as a mouse and/or keyboard and a personal computer or laptop
VARS	<i>Variables</i> , the variable settings of the instrument
V-F	<i>Voltage-to-Frequency</i>
Z/S	<i>Zero / Span</i>