

Use and Disclosure of Data
Information contained herein is classified as EAR99 under the
U.S. Export Administration Regulations.
Export, reexport or diversion contrary to U.S. law is prohibited.

OPERATING INSTRUCTIONS FOR INSTA TRANS-XD

Trace and Percent Oxygen Digital Transmitter



P/N M82620
ECO 17-0078
7-01-17



DANGER



Toxic gases and or flammable liquids may be present in this monitoring system.
Personal protective equipment may be required when servicing this instrument.
Only authorized personnel should conduct maintenance and/or servicing.
Before conducting any maintenance or servicing, consult with authorized
supervisor/manager.

EU DECLARATION OF CONFORMITY

This declaration of conformity is issued under the sole responsibility of the manufacturer

APPLICATION OF COUNCIL ATEX DIRECTIVE : 2014/34/EU

STANDARDS TO WHICH : EN61326-1: 2013
EN55011 Class A Group 1
EN 60079-0:2012+All:2014
(IBC 60079-0:2011)

CONFORMITY IS DECLARED : EN 60079-11:2012
(IEC 60079-11:2011)

MANUFACTURER'S NAME : Teledyne Analytical Instruments

MANUFACTURER'S ADDRESS : 16830 Chestnut Street
City of Industry, CA 91748
U.S.A.

TYPE OF EQUIPMENT : Oxygen Measuring Transmitter
Type Insta Trans-XD

EQUIPMENT CLASS : Ex II IG Ex ia IIC T4 Ga
(0°C ≤ Ta ≤ +50°C)

MODEL NUMBER : Insta Trans-XD

I, the undersigned, hereby declare that the equipment specified above conforms to the referenced standards per 2014/34/EU and have been type-approved by SGS Fimko Oy, Takomotie 8, FI-00380 Helsinki, Finland. SGS Fimko Oy, notified body identification number 0598. Mark: Ex II IG. Code: Ex ia IIC T4 Ga

EC Type Certificate Number: Baseefa12ATEX0114X

IECEX Certificate Number: IECEX BAS 12.0078X

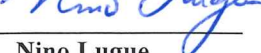
SIGNATURE: 
FULL NAME: Nino Lague
POSITION: QA Analyst
Date: 12-13-22
PLACE: City of Industry, California

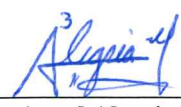
SIGNATURE: 
FULL NAME: Angel Alegria
POSITION: New Products Engineer
Date: 12-13-22
PLACE: City of Industry California

Copyright © 2017 Teledyne Analytical Instruments

All Rights Reserved. No part of this manual may be reproduced, transmitted, transcribed, stored in a retrieval system, or translated into any other language or computer language in whole or in part, in any form or by any means, whether it be electronic, mechanical, magnetic, optical, manual, or otherwise, without the prior written consent of Teledyne Analytical Instruments, 16830 Chestnut Street, City of Industry, CA 91748.

Warranty

This equipment is sold subject to the mutual agreement that it is warranted by us free from defects of material and of construction, and that our liability shall be limited to replacing or repairing at our factory (without charge, except for transportation), or at customer plant at our option, any material or construction in which defects become apparent within one year from the date of shipment, except in cases where quotations or acknowledgements provide for a shorter period. Components manufactured by others bear the warranty of their manufacturer. This warranty does not cover defects caused by wear, accident, misuse, neglect or repairs other than those performed by Teledyne or an authorized service center. We assume no liability for direct or indirect damages of any kind and the purchaser by the acceptance of the equipment will assume all liability for any damage which may result from its use or misuse.

We reserve the right to employ any suitable material in the manufacture of our apparatus, and to make any alterations in the dimensions, shape or weight of any parts, in so far as such alterations do not adversely affect our warranty.

Important Notice

This instrument provides measurement readings to its user, and serves as a tool by which valuable data can be gathered. The information provided by the instrument may assist the user in eliminating potential hazards caused by his process; however, it is essential that all personnel involved in the use of the instrument or its interface, with the process being measured, be properly trained in the process itself, as well as all instrumentation related to it.

The safety of personnel is ultimately the responsibility of those who control process conditions. While this instrument may be able to provide early warning of imminent danger, it has no control over process conditions, and it can be misused. In particular, any alarm or control systems installed must be tested and understood, both as to how they operate and as to how they can be defeated. Any safeguards required such as locks, labels, or redundancy, must be provided by the user or specifically requested of Teledyne at the time the order is placed.

Therefore, the purchaser must be aware of the hazardous process conditions. The purchaser is responsible for the training of personnel, for providing hazard warning methods and instrumentation per the appropriate standards, and for ensuring that hazard warning devices and instrumentation are maintained and operated properly.

Teledyne Analytical Instruments, the manufacturer of this instrument, cannot accept responsibility for conditions beyond its knowledge and control. No statement expressed or implied by this document or any information disseminated by the manufacturer or its agents, is to be construed as a warranty of adequate safety control under the user's process conditions.

Oxygen Transmitter

Specific Model Information

The instrument for which this manual was supplied may incorporate one or more options not supplied in the standard instrument. Commonly available options are listed below, with check boxes. Any that are incorporated in the instrument for which this manual is supplied are indicated by a check mark in the box.

Instrument Serial Number: _____

Cell Class:

B1 B2C A2C
 A5 L2C Insta-Trace Other _____

Insta Trans-XD Transmitter Model: _____

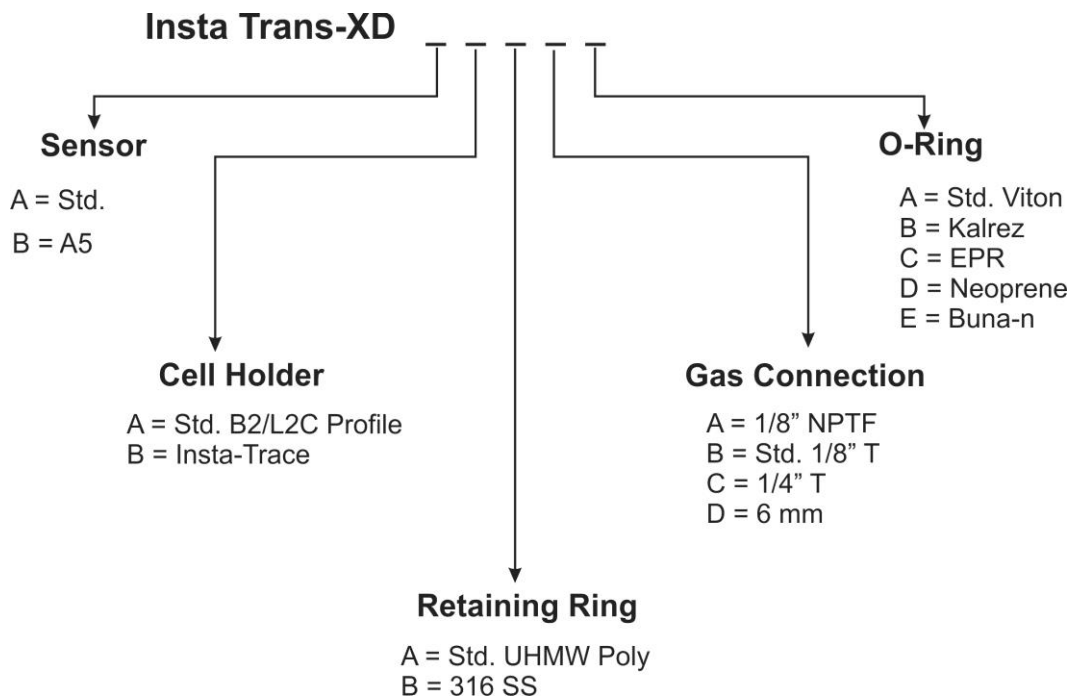

Safety Messages

Your safety and the safety of others are very important. We have provided many important safety messages in this manual. Please read these messages carefully.

A safety message alerts you to potential hazards that could hurt you or others. Each safety message is associated with a safety alert symbol. These symbols are found in the manual and inside the instrument. The definition of these symbols is described below:

GENERAL WARNING/CAUTION: Refer to the instructions for



details on the specific danger. These cautions warn of specific procedures which if not followed could cause bodily injury and/or damage the instrument.

CAUTION: HOT SURFACE WARNING: This warning is specific to



heated components within the instrument. Failure to heed the warning could result in serious burns to skin and underlying tissue.

Technician Symbol: All operations marked with this symbol are to be performed by qualified maintenance personnel only.



NOTE:

No
Symbol

Additional information and comments regarding a specific component or procedure are highlighted in the form of a note.

CAUTION: THE ANALYZER SHOULD ONLY BE USED ONLY FOR THE PURPOSE AND IN THE MANNER DESCRIBED IN THIS MANUAL.



IF YOU USE THE ANALYZER IN A MANNER OTHER THAN THAT FOR WHICH IT WAS INTENDED, UNPREDICTABLE BEHAVIOR COULD RESULT POSSIBLY ACCOMPANIED WITH HAZARDOUS CONSEQUENCES.

This manual provides information designed to guide you through the installation, calibration operation and maintenance of your new analyzer. Please read this manual and keep it available.

Occasionally, some instruments are customized for a particular application or features and/or options added per customer requests. Please check the front of this manual for any additional information in the form of an Addendum which discusses specific information, procedures, cautions and warnings that may be peculiar to your instrument.

Manuals do get lost. Additional manuals can be obtained from Teledyne at the address given in the Appendix. Some of our manuals are available in electronic form via the internet. Please visit our website at: www.teledyne-ai.com.

Safety Information

WARNING: *Substitution of components may impair intrinsic safety.*



WARNING: *To prevent ignition of flammable or combustible atmospheres, read, understand and adhere to the manufacturer's live maintenance procedures.*



WARNING: *Potential electrostatic charging hazard. The enclosure contains plastic. To prevent the risk of electrostatic sparking the plastic surface should be cleaned only with a damp cloth.*



WARNING: *The apparatus enclosure contains aluminum and is considered to constitute a potential risk of ignition by impact or friction. Care must be taken into account during installation and use to prevent impact or friction.*



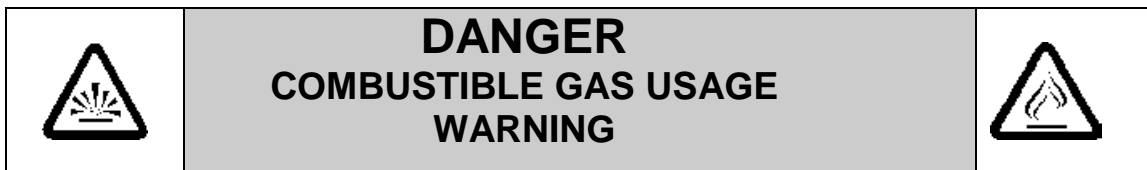

This is a general purpose instrument designed for use in a nonhazardous area. It is the customer's responsibility to ensure safety especially when combustible gases are being analyzed since the potential of gas leaks always exist.

The customer should ensure that the principle of operating of this equipment is well understood by the user. Misuse of this product in any manner, tampering with its components, or unauthorized substitution of any component may adversely affect the safety of this instrument.

Since the use of this instrument is beyond the control of Teledyne, no responsibility by Teledyne, its affiliates, and agents for damage or injury from misuse or neglect of this equipment is implied or assumed.

Certification/Approvals and Special Instructions

Factory Mutual (FM)



TAI Model Insta Trans-XD IS Ex ia
CL I, Div 1, Gp ABCD T4 @ Ta= 0 °C to 50 °C

TAI Model Insta Trans-XD Nonincendive for
CL I, Div 2, Gp ABCD T4 @ Ta= 0 oC to 50 oC

Refer to control drawing D92719

Oxygen Transmitter

ATEX Certification and Special Conditions for Safe Use



CE₁₁₈₀ Baseefa12ATEX0114X



Ex ia IIC T4 Ga
0° < Ta < +50°C

Symbol X:

Warning! This instrument is not designed for use with oxygen enriched gases, i.e. gases with an oxygen content greater than 21%.

Warning! This instrument uses an aluminum case. Protect against impact or friction to minimize ignition risks. Clean with a damp cloth to prevent electrostatic discharge, and must not be installed where it could be subjected to high airflow dust laden atmospheres.

The electrical connections are not isolated from ground. This must be taken into account during installation and use.

Table of Contents

| | |
|---|-------------|
| Specific Model Information | iii |
| Safety Messages | iv |
| Safety Information | vi |
| Certification/Approvals and Special Instructions | viii |
| Factory Mutual (FM) | viii |
| ATEX Certification and Special Conditions for Safe Use | ix |
| Table of Contents | xi |
| List of Figures | xiii |
| Introduction | 1 |
| 1.1 Overview | 1 |
| 1.2 Typical Applications | 1 |
| 1.3 Main Features of the Transmitter | 1 |
| 1.4 Operator Interface | 2 |
| Operational Theory | 5 |
| 2.1 Introduction | 5 |
| 2.2 Oxygen Sensor | 5 |
| 2.2.1 Principles of Operation | 5 |
| 2.2.2 Anatomy of a Micro-fuel Cell | 6 |
| 2.2.3 Electrochemical Reactions | 7 |
| 2.2.4 The Effect of Pressure | 8 |
| 2.2.5 Calibration Characteristics | 8 |
| 2.3 Sample System | 10 |
| 2.4 Electronics and Signal Processing | 11 |
| Installation | 13 |
| 3.1 Unpacking the Transmitter | 13 |

| | |
|---|-----------|
| 3.2 Mounting the Transmitter | 13 |
| 3.3 Gas Connections | 13 |
| 3.4 Electrical Connections | 15 |
| 3.5 Installing the Oxygen Sensor | 16 |
| 3.6 Powering UP and Testing the System | 17 |
| Operation | 19 |
| 4.1 Introduction | 19 |
| 4.2 The <i>Range</i> and <i>Calibration</i> Functions | 19 |
| 4.3 Range Setting | 20 |
| 4.4 Calibration | 20 |
| 4.4.1 Span Calibration | 21 |
| 4.4.2 4-20 mA Adjustment | 21 |
| 4.5 No Sensor Installed Detection Feature | 22 |
| 4.6 Cold Boot | 24 |
| Maintenance | 27 |
| 5.1 Routine Maintenance | 27 |
| 5.2 Cell Replacement | 27 |
| 5.2.1 Storing and Handling Replacement Cells | 27 |
| 5.2.2 When to Replace a Cell | 28 |
| 5.2.3 Removing the Oxygen Sensor | 29 |
| 5.2.4 Cell Warranty | 29 |
| 5.3 Insta-Trace Sensor | 31 |
| Appendix..... | 33 |
| Specifications | 33 |
| Recommended Spare Parts List | 36 |
| Drawings | 37 |

List of Figures

| | |
|--|----|
| Figure 1-1: Insta Trans-XD User Interface..... | 3 |
| Figure 2-1: Micro-fuel Cell | 6 |
| Figure 2-2: Cross Section of a Micro-fuel Cell (not to scale) | 7 |
| Figure 2-3: Characteristic Input/output Curve for a Micro-fuel Cell..... | 9 |
| Figure 2-4: Gas and Power/Signal Connections to the Transmitter | 10 |
| Figure 2-5: Insta Trans-XD Internal Electronics..... | 11 |
| Figure 2-6: Electronics Block Diagram | 12 |
| Figure 3-1: Insta Trans-XD Connections and Mounting Dimensions | 14 |
| Figure 4-1: No Sensor Display Warning | 23 |
| Figure 4-2: Disabled 'No Sens' Warning | 24 |
| Figure 5-1: Cell Removal..... | 30 |
| Figure 5-2: Cell Removal Insta-Trace..... | 32 |

[This page is intentionally blank]

Introduction

1.1 Overview

The Teledyne Analytical Instruments Insta Trans-XD Oxygen Digital Transmitter is a versatile instrument for measuring the oxygen content in a gas sample. This manual covers the Insta Trans-XD Oxygen Digital Transmitter for both the ATEX and FM certified instruments. These units are rated Intrinsically Safe (IS) when installed per the Interconnection Diagram D86181 for ATEX instruments or Interconnection Diagram D92719 for FM instruments and may be used in hazardous environments as listed in the Specifications in the Appendix.

1.2 Typical Applications

A few typical applications of the Insta Trans-XD are:

- Monitoring inert gas blanketing
- Air separation and liquefaction
- Chemical reaction monitoring
- Semiconductor manufacturing
- Petrochemical process control
- Quality assurance
- Gas analysis certification.

1.3 Main Features of the Transmitter

The Insta Trans-XD Oxygen Transmitter is sophisticated yet simple to use. The main features of the analyzer include:

- Digital microprocessor based analyzer.
- 3½ digit LCD display with range and calibration annunciators.

- User settable analysis range from 0-10 ppm through 0-25% (sensor dependent).
- Stainless steel cell block.
- Simple push-button calibration and range selection.
- Advanced trace or percent oxygen sensor has a one-year warranty and an expected lifetime of two years.
- Air-calibration range for convenient spanning at 20.9 %.
- True 2-wire 4-20 mA powered loop interface.

1.4 Operator Interface

The standard Insta Trans-XD is housed in a rugged metal case with all switches and the display accessible from the outside. Figure 1-1 illustrates the Insta Trans-XD display and switches.

Function Keys: Four touch-sensitive membrane switches are used to set the range and calibrate the transmitter.

- **ENT** Pressing Enter once selects the Range mode. Pressing Enter twice enters Calibration mode. Enter is also used to accept user input.
- **ESC** Rejects user input and returns display to Analyze mode.
- **▲** Used to adjust input values or range selection upward.
- **▼** Used to adjust input values or range selection downward.
- **DISPLAY** 3 1/2 digit O₂ concentration LCD display with annunciators

Depending on the operational mode of the instrument, the display will blink and a final character at the rightmost position of the screen will appear informing the user of the specific mode and function. The characters used and the function are indicated in Table 1-1.

Table 1-1: Function and Display Indicator

| Function | Display Indicator |
|---------------------------------------|--|
| Range | |
| 0-10 ppm through 0-25% (user defined) | No indicator (display not blinking) analysis mode R (Range setting mode) display blinking P (Percent value) |
| Calibration | |
| Span | S (display blinking) |
| 4-20 mA Adjust | |
| 4.00 (low end) | L (display blinking) |
| 20.0 (high end) | H (display blinking) |



Figure 1-1: Insta Trans-XD User Interface

[This page is intentionally blank]

Operational Theory

2.1 Introduction

The transmitter is composed of three subsystems:

1. Oxygen Sensor
2. Sample System
3. Electronic Signal Processing, Display and Control

The sample system is designed to accept the sample gas and transport it through the transmitter without contaminating or altering the sample prior to analysis. The sensor is a micro-fuel cell which is an electrochemical galvanic device that translates the amount of oxygen present in the sample into an electrical current. The electronic signal processing, display and control circuits simplify operation of the transmitter and accurately displays the sampled data.

2.2 Oxygen Sensor

2.2.1 Principles of Operation

The oxygen sensor used in the Insta Trans-XD series is a micro-fuel cell designed and manufactured by Teledyne Analytical Instruments. It is a sealed plastic disposable electrochemical transducer.

The active components of the sensor are a cathode, an anode, and the 15% aqueous KOH electrolyte in which they are immersed. The cell converts the energy from a chemical reaction into an electrical current in an external electrical circuit. Its action is similar to that of a battery.

There is, however, an important difference in the operation of a battery as compared to a micro-fuel cell. In the battery, all reactants are stored within the cell, whereas in the micro-fuel cell, one of the reactants (oxygen) comes from outside the device as a constituent of the sample gas being analyzed. The micro-fuel cell is therefore a hybrid between a battery and a true fuel cell. (All of the reactants are stored externally in a true fuel cell.)

2.2.2 Anatomy of a Micro-fuel Cell

The Micro-fuel Cell is a cylinder only 1¼ inch in diameter with a length dependent on the particular cell. It is made of an extremely inert plastic, which can be placed confidently in practically any environment or sample stream. It is effectively sealed, although one end is permeable to the sample gas. The other end of the cell is a contact plate consisting of two concentric foil rings. The rings mate with spring-loaded contacts in the sensor block assembly and provide the electrical connection to the rest of the analyzer. Figure 2-1 illustrates the external features.

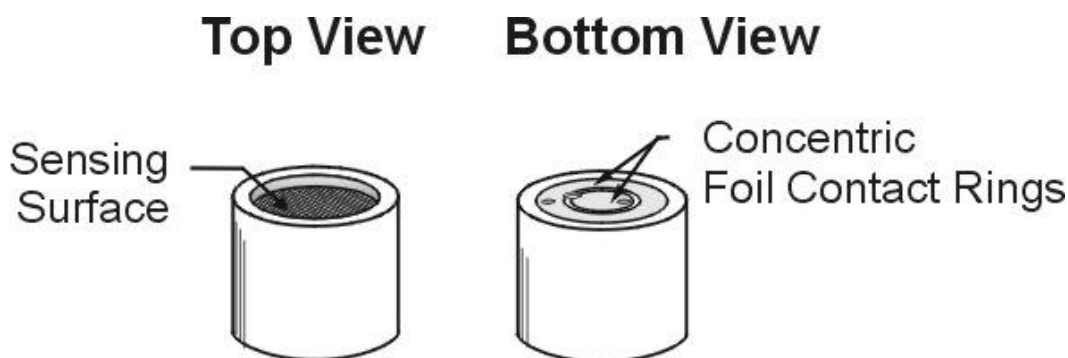

Figure 2-1: Micro-fuel Cell

Refer to Figure 2-2, *Cross Section of a Micro-fuel Cell*, which illustrates the following internal description.

At the top end of the cell is a diffusion membrane of Teflon[®], whose thickness is very accurately controlled. Beneath the diffusion membrane lies the oxygen sensing element—the cathode—with a surface area almost 4 cm². The cathode has many perforations to ensure sufficient wetting of the upper surface with electrolyte, and it is plated with an inert metal.

The anode structure is below the cathode. It is made of lead and has a proprietary design which is meant to maximize the amount of metal available for chemical reaction.

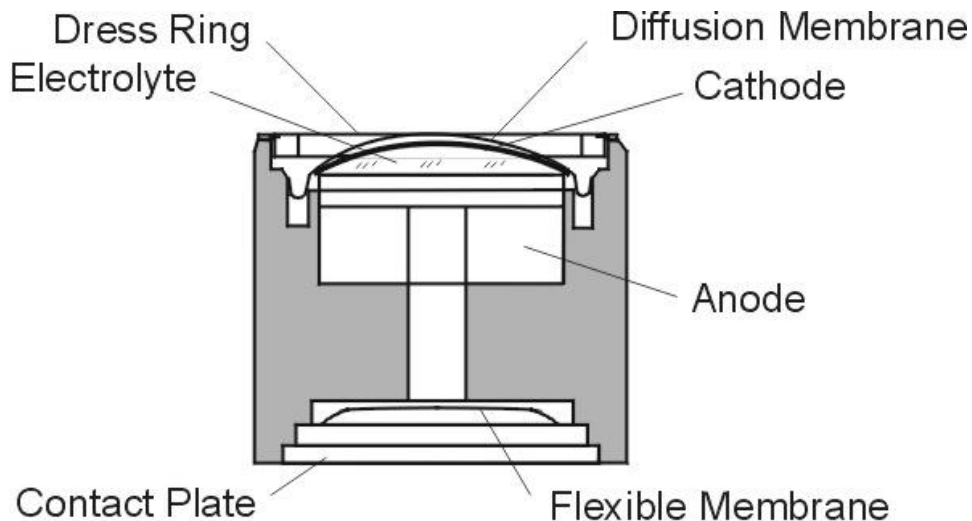

Figure 2-2: Cross Section of a Micro-fuel Cell (not to scale)

At the rear of the cell, just below the anode structure, is a flexible membrane designed to accommodate the internal volume changes that occur throughout the life of the cell. This flexibility assures that the sensing membrane remains in its proper position, keeping the electrical output constant.

The entire space between the diffusion membrane, above the cathode, and the flexible rear membrane, beneath the anode, is filled with electrolyte. Cathode and anode are submerged in this common pool. They each have a conductor connecting them to one of the external contact rings on the contact plate, which is on the bottom of the cell.

2.2.3 Electrochemical Reactions

The sample gas diffuses through the Teflon membrane. Any oxygen in the sample gas is reduced on the surface of the cathode by the following HALF REACTION:



(Four electrons combine with one oxygen molecule—in the presence of water from the electrolyte—to produce four hydroxyl ions.)

When the oxygen is reduced at the cathode, lead is simultaneously oxidized at the anode by the following HALF REACTION:

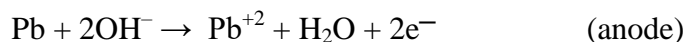

(Two electrons are transferred for each atom of lead that is oxidized. Therefore it takes two of the above anode reactions to balance one cathode reaction and transfer four electrons.)

The electrons released at the surface of the anode flow to the cathode surface when an external electrical path is provided. The current is proportional to the amount of oxygen reaching the cathode. It is measured and used to determine the oxygen concentration in the gas mixture.

The overall reaction for the fuel cell is the SUM of the half reactions above, or:

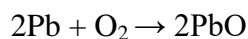

(These reactions will hold as long as no gaseous components capable of oxidizing lead—such as iodine, bromine, chlorine and fluorine—are present in the sample.)

The output of the fuel cell is limited by (1) the amount of oxygen in the cell at the time and (2) the amount of stored anode material.

In the absence of oxygen, no current is generated.

2.2.4 The Effect of Pressure

In order to state the amount of oxygen present in the sample in parts-per-million or a percentage of the gas mixture, it is necessary that the sample diffuse into the cell under constant pressure.

If the total pressure increases, the rate that oxygen reaches the cathode through the diffusing membrane will also increase. The electron transfer, and therefore the external current, will increase, even though the oxygen concentration of the sample has not changed. It is therefore important that the sample pressure at the fuel cell (usually vent pressure) remain relatively constant between calibrations.

2.2.5 Calibration Characteristics

Given that the total pressure of the sample gas on the surface of the Micro-fuel Cell input is constant, a convenient characteristic of the cell is that the current produced in an external circuit is directly proportional to the rate at which oxygen molecules reach the cathode, and this rate is directly proportional to the concentration of oxygen in the gaseous mixture. In other words it has a linear characteristic curve, as shown in

Figure 2-3. Measuring circuits do not have to compensate for nonlinearities.

In addition, since there is zero output in the absence of oxygen, the characteristic curve has close to an absolute zero (within ± 0.5 ppm oxygen).

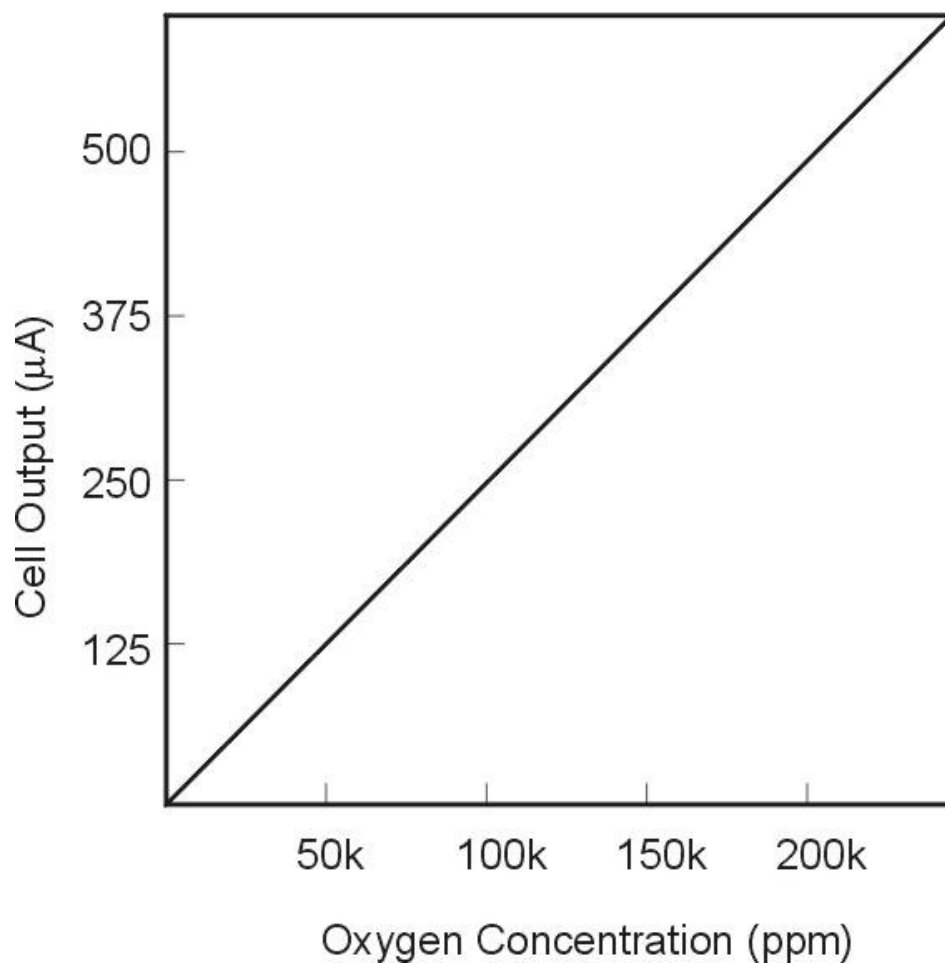

Figure 2-3: Characteristic Input/output Curve for a Micro-fuel Cell

2.3 Sample System

Internal piping delivers gases to the sensor from the transmitter gas inlet. Depending on the mode of operation either sample or calibration gas is delivered.

The Insta Trans-XD is designed and fabricated to ensure that the oxygen concentration of the gas is not altered as it travels through the internal piping. The sample encounters almost no dead space. This minimizes residual gas pockets that can interfere with trace analysis.

Sample inlet and outlet connections are typically 1/8", 1/4", or 6 mm tube fittings (see page iii). The sample gas flows through the transmitter as shown in Figure 2-4. Since there is no flow regulation in the unit, a flow regulating device such as needle valve or flow controller should be used upstream. TAI recommends using a flowrate between 1-2 slpm.



Figure 2-4: Gas and Power/Signal Connections to the Transmitter

2.4 Electronics and Signal Processing

The Insta Trans-XD Oxygen Transmitter uses standard electronic circuitry. Power is supplied via the 4-20 mA current loop.

The processing electronics are located inside the transmitter housing. The single PC board shown in Figure 2-5 is accessible after removing the front cover of the housing. Figure 2-6 is a block diagram of the transmitter electronics.

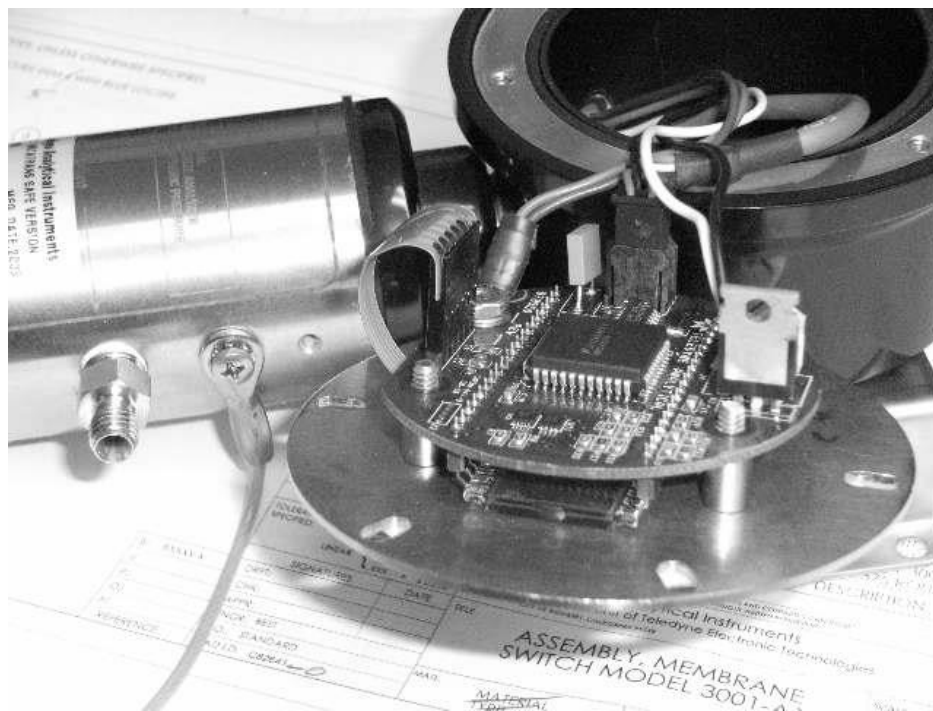

Figure 2-5: Insta Trans-XD Internal Electronics

In the presence of oxygen the cell generates a current. A current to voltage amplifier converts this current to a voltage, which is amplified in the second stage amplifier.

The second stage amplifier also supplies temperature compensation for the oxygen sensor output. This amplifier circuit incorporates a thermistor, which is physically located in the cell block. The thermistor is a temperature dependent resistance that changes the gain of the amplifier in proportion to the temperature changes in the block. This

change is inversely proportional to the change in the cell output due to the same temperature changes. The result is a signal that is temperature independent. The output from the second stage amplifier is sent to the Analog to Digital converter, or ADC. The conversion is sent to a microprocessor.

The microprocessor computes the oxygen value and passes this value to the 3-1/2 digit LCD display. The LCD display provides a visual indication of the oxygen concentration in ppm or % depending on the range selected. Range selection and calibration information are entered from the keypad and processed by the microcontroller. All power needed to run the Insta Trans-XD transmitter is derived from the signal current loop. Range and calibration settings are maintained indefinitely when the signal current loop is disconnected. They are stored in an EEPROM. The transmitter always defaults to Run mode when the signal current loop is connected after an initialization countdown.

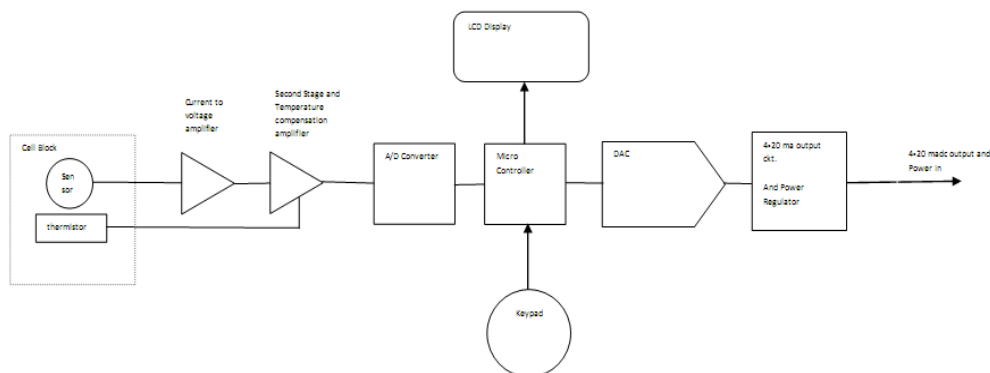

Figure 2-6: Electronics Block Diagram

Installation

Installation of the Insta Trans-XD Transmitter includes:

- Unpacking
- Mounting
- Gas connections
- Electrical connections
- Installing the oxygen sensor
- Testing the system.

3.1 Unpacking the Transmitter

The transmitter is shipped with all the materials you need to install and prepare the system for operation. Carefully unpack the transmitter and inspect it for damage. Immediately report any damage to the shipping agent.

3.2 Mounting the Transmitter

The Insta Trans-XD transmitter is provided with a wall mount bracket. Refer to Figure 3-1 and the Outline Drawing in the Appendix for mounting information and dimensions. The display and operator control switches are located on the top of the transmitter. This should be taken into consideration when determining mounting location. Mount the transmitter with the sensor housing vertical and the cell holder on the bottom.

3.3 Gas Connections

The unit is manufactured with various sized tube fittings. See page iii for specific size fittings on your instrument.

For a safe connection:



1. Insert the tube into the tube fitting, and finger-tighten the nut until the tubing in the fitting cannot be rotated freely by hand. (This may require an additional 1/8 turn beyond finger-tight.)
2. Hold the fitting body steady with a backup wrench, and with another wrench rotate the nut another 1-1/4 turns.

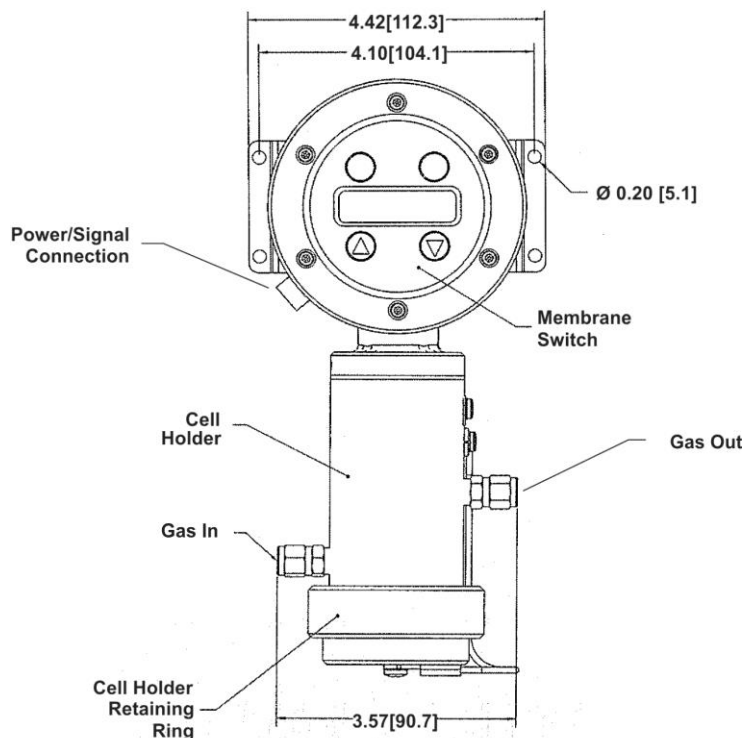

Figure 3-1: Insta Trans-XD Connections and Mounting Dimensions

SAMPLE IN: Gas connections are made at the GAS IN and GAS OUT connections.

The gas pressure in should be reasonably regulated. A flow control device must be installed before the sample in port if the sample pressure is above 0.5 psig. TAI recommends using a flowrate between 1-2 SLPM (2.12-4.24 scfh).

If greater flow is required for improved response time (over 9.4 slpm or 20 SCFH), install a bypass in the sampling system upstream of the analyzer input.

GAS OUT: Gas out connections must be consistent with the hazard level of the constituent gases. Check local, state, and federal laws, and ensure that the exhaust stream vents to an appropriately controlled area if required. The exhaust should be vented to atmospheric pressure, through a short length of tubing (3'). The vent tubing should not be less than 1/8".

The GAS IN and GAS OUT ports are used for both the sample and calibration gases. Typically the user will install appropriate valves for switching between sample and calibration gas fed to the transmitter. Alternatively, the user may disconnect the sample gas and connect the calibration gas to the GAS IN port when calibration is required.

Note: Connecting and disconnecting gas lines will result in air entering the cell and saturating the sensor. A lengthy purge cycle may be required before low concentration oxygen measurements can be performed.

3.4 Electrical Connections

The Insta Trans-XD analyzer requires two electrical connections. A chassis ground connection should be made to the left side of the mounting bracket. This is required to reduce the sensitivity to radio frequency interference (RFI). An adequate ground connection can be established by mounting the analyzer to a metal structure, or attaching a ground cable with lug (3/8") to the left side mounting bolt.

The signal and power are supplied by a single 4-pin electrical connector on the left side of the analyzer. The Insta Trans-XD is supplied with a twenty-four inch cable which mates with the power/signal connector. Other cable lengths are available or the mating connector can be supplied for customer use, see spare parts list in the rear of the manual.

Wiring: The Insta Trans-XD is equipped with a four-pin removable connector (screw connections). The connector allows the user to easily install or remove the analyzer. The connector should be wired according to the Wiring Diagram and the Interconnection Diagram included in the Appendix.

The cable or wire required will depend on the specific application. A shielded cable should be used whenever possible to improve resistance to radio interference. The wire gauge should be selected based on the length of the cable. A minimum wire gauge of 22 is recommended. The

maximum wire gauge is limited by the size of the connector. A larger gauge wire is required for longer cable runs due to the voltage drop associated with the cable resistance. A 1000 foot 22 gauge cable will have a voltage drop of 0.59 VDC (29.5 ohms x 20ma) at full scale. A 1000 foot 18 gauge cable will have a voltage drop of 0.26 VDC (12.96 ohms x 20ma). The above voltage will be added to the minimum voltage required for the transmitter.

A typical installation will include a load resistor. The value of the resistor is dependent on the full-scale output voltage signal required. For a full-scale output of 5 VDC the resistor value is 250 ohms (5V/20mA.). For a full-scale output of 1 VDC the resistor value will be 50 ohms (1V/20mA). The output voltage is also added to the minimum voltage for the transmitter.

The operating voltage range of the transmitter is 9 – 24 VDC. The wiring and load resistor voltage drops must be included in determining the minimum voltage requirement. The minimum operating voltage required with a 500 foot 20 gauge cable and a 250 ohm load resistor is 14.4 VDC (9.3V + (5.1 + 250) ohms x 20ma).

For Intrinsically Safe (IS) installation, special considerations are required. The Insta Trans-XD analyzer has been designed to be Intrinsically Safe when used with a properly selected and installed safety barrier. This design utilizes redundant safety features to prevent the Insta Trans-XD from becoming an ignition source in the event of a circuit failure.

To meet FM Nonincendive requirements, connection to equipment must be through Nonincendive Field Wiring with following parameters:

$$V_{oc} < 30 \text{ volts}$$

$$L < 100 \text{ mH}$$

$$C < 3 \text{ uF}$$

The user should consult with the proper certifying agency prior to installation. Safety barriers reduce the possibility of fires or explosion in hazardous locations by limiting the energy available for ignition. .

3.5 Installing the Oxygen Sensor

The oxygen sensor (micro-fuel cell) is not installed in the cell block when the instrument is shipped. It must be installed before the analyzer is placed in service.

Once it is expended, or if the cell (for trace O₂ applications) is exposed to air for too long, the sensor will need to be replaced (B1 cells are designed for use in percent levels of O₂ such as air). The cell could also require replacement if the instrument has been idle for too long.

When the oxygen sensor needs to be installed or replaced, follow the procedures in Chapter 5, *Maintenance*, for removing and installing cells.

3.6 Powering UP and Testing the System

Before connecting the signal wires to the transmitter:

- Check the integrity and accuracy of the gas connections. Make sure there are no leaks.
- Verify that the restriction device has been properly installed (see section 3.3).
- Check that inlet sample pressure is within the accepted range (see section 3.3).

Connect the signal wires and energize the signal line, and test the transmitter by performing the following:

1. Observe that the LCD display illuminates and that the transmitter powers up indicating first the Model Number quickly followed by the software revision number. The display will then begin a countdown from 74 to 0 while internal diagnostic tests are being performed. The transmitter will then automatically enter Run mode.
2. If the right three digits of the LCD display are blank, the transmitter is in an over range condition. Push the **ENT** button once to enter the Range Select mode. Use the **UP** or **DOWN** keys until the transmitter displays an “in range” condition.

Note: The transmitter can display a 99.9% over range condition, so select a range where the left-most digit is blank.

3. The unit will time out if another button is not pressed after a few seconds and return to Run mode.

[This page is intentionally blank]

Operation

4.1 Introduction

Once the transmitter has been installed, it must be configured to your application. To do this you must:

- Set the range.
- Calibrate the instrument.
 - Span calibration
 - 4-20 mA adjust

4.2 The *Range* and *Calibration* Functions

The transmitter is calibrated by using span gas. Use the same flow rate as for sample gas, i.e. 1-2 SLPM (2.12-4.24 SCFH).

Although the instrument can be spanned using air, a span gas with a known oxygen concentration in the range of 70–90% of full scale of the range of interest is recommended. Since the oxygen concentration in air is 20.9% (209,000 ppm), the cell can take a long time to recover if the instrument is used for trace oxygen analysis immediately following calibration in air.

Connect the calibration gases to the transmitter according to the instructions given in Section 3.3, *Gas Connections*, observing all the prescribed precautions.

The gas supply should be off or set to a low flow before connecting it to the transmitter. Do not block or obstruct the sample vent.

CAUTION: IN THE EVENT OF LOSS OF FLOW THROUGH THE TRANSMITTER, IF THE VENT IS VENTED TO A LOCATION OF HIGH OXYGEN CONTENT, OXYGEN WILL BACK DIFFUSE THROUGH THE VENT LINE AND IN MOST CASES QUICKLY SATURATE THE CELL WITH OXYGEN. THIS MAY THEN REQUIRE A



LONG PURGE DOWN TIME BEFORE MAKING LOW OXYGEN CONCENTRATION MEASUREMENTS. IN THE EVENT THAT FLOW IS INTERRUPTED INTO THE TRANSMITTER, IT IS SUGGESTED THAT THE USER DO ONE OF THE FOLLOWING:

1. Bag the sensor in nitrogen during this time
2. Install a shut off valve on the vent port of the transmitter or somewhere within the users sample system.

4.3 Range Setting

The Insta Trans-XD Transmitter can be set to any range from 0-10 ppm to 0-25 percent. The 0-10 ppm range is limited to instruments with trace sensors installed.

To set the range:

1. With the unit powered on and in Run mode, Press **ENT** once. A small 'r' appears in the lower right corner of the display to indicate you are in range setting mode.
2. Use the **UP/DOWN** keys to set the upper bound of the range. Single presses will increment or decrement the value by 1.

Note: The function will time out and return to analyze mode if no arrow button is pressed within a few seconds.

If the value is incremented beyond 1000 ppm the display automatically changes to a percent display and the letter "P" will appear to the right of the number.

3. The displayed range will be blinking. After a few seconds the display will stop blinking indicating that the value has been accepted and the upper bound of the range has been set and will return to Run mode using that range.

4.4 Calibration

Calibration involves span calibrating the instrument to a known oxygen concentration and adjusting the 4-20 mA output signal.

4.4.1 Span Calibration

The 0-25% range allows for convenient air calibration (20.9% O₂) however, this is not advisable for trace oxygen sensors. While the Insta-Trace-XL sensor is specially designed for rapid recovery after exposure to air, it should not be calibrated using air. Percent oxygen sensors can be calibrated with air.

TAI recommends using a prepared, known concentration of oxygen in a compatible gas such as nitrogen that is 70-90% of the anticipated range of interest.

Span calibration involves entering the known concentration into the instrument while the known standard is flowing through the transmitter. To span calibrate the instrument:

1. Attach a proper span gas source to the SAMPLE IN port (or open to air) and allow the gas to flow through the transmitter (1-2 slpm/2.12-4.24 scfh).
2. Press **ENT** twice to enter Calibration mode. The current span calibration value will appear blinking along with the letter “S” in the rightmost position of the display.
3. Use the **UP/DOWN** keys to change the blinking value to the known value of the span gas.
4. After a few moments without any further key presses, the display will time out and stop blinking. The “S” will disappear and the transmitter will be calibrated. The transmitter will automatically return to Run mode.
5. Remove the span gas and reconnect sample gas to the SAMPLE IN port.

*Note: Pressing **ESC** at anytime in the calibration procedure will terminate the span calibration and return the unit to Run mode. The original span value will remain unchanged.*

4.4.2 4-20 mA Adjustment

Periodically, as required, and always when powering up after a cold boot (See Section 4.3), the 4-20 mA signal output will need to be calibrated. This is accomplished by attaching a DVM in current mode (mA) in series with the power input cable. When the Insta Trans-XD is placed in 4-20 mA Calibration mode, the output will display on the

DVM and can be adjusted to the low end (4 mA) followed by the high end (20 mA).

To adjust the 4-20 mA output signal you will need a digital voltmeter (DVM) capable of reading a 0-20 mA current. Proceed as follows:

1. Attach a DVM in series on the power input cable. Make sure the DVM is switched to mA current at a suitable scale.
2. Power OFF the Insta Trans-XD.
3. While pressing and holding the escape (**ESC**) key, power the unit back ON. This will place the Insta Trans-XD in 4-20 mA Calibration mode and the display will blink while showing the character “L” at the rightmost position of the display referring to the low end of the 4-20 range i.e. 4 mA.
4. While watching the DVM display (not the Insta Trans-XD display), use the **UP/DOWN** keys to adjust the DVM display as close to 4.00 mA as possible. Press **ENT** when the value is sufficiently close to 4.00 mA.
5. After pressing **ENT**, the unit will accept the low end calibration and move to the high endpoint (20 mA). Note that the Insta Trans-XD display is once again blinking with the character “H” displayed at the rightmost position of the display.
6. While watching the DVM display (not the Insta Trans-XD display), use the **UP/DOWN** keys to adjust the DVM display as close to 20.00 mA as possible. Press **ENT** when the value is sufficiently close to 20.00 mA.
7. After pressing **ENT**, the Insta Trans-XD will resume the power up routine as described in Section 3.6.

Note: The 4-20 mA output must ALWAYS be readjusted whenever the instrument has undergone a cold boot. See Section 4.5.

4.5 No Sensor Installed Detection Feature

Newer versions of the software (version 1.03 or higher), have a feature where it checks if sensor is installed in the cell block. It is designed to prevent accidentally installing the analyzer without a sensor present.

With this feature, if the input to the oxygen amplifier is zero for 30 minutes, the display will show “no SEnS” (display alternates between “no” and “SEnS”). See Figure 4-1.

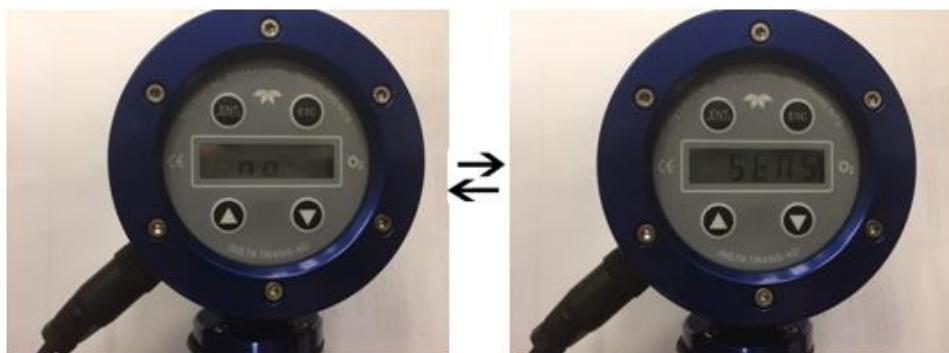

Figure 4-1: No Sensor Display Warning

The 4-20 ma current output will drop to 3.6 mA to indicate a fault to a remote PLC (if installed).

Before unit triggers this alarm, the 30 minute timer can be checked by pressing the ESC key once. The display will show the time remaining in minutes before the alarm is triggered. A value of 30.0 means it is not counting down, but any value less than 30 will show the time remaining in minutes before the no sensor alarm is triggered.

From software version 1.04 or higher, it is also possible to disable this alarm either before or after the no sensor alarm is triggered. This might be desirable on the rare occasion that a sensor offset is so low that it might look to the analyzer that there is no sensor installed and trigger the false alarm. This does not mean the sensor is bad as this feature is only to prevent accidental installation of the analyzer without sensor.

To disable the feature, press and hold the UP key button for 10 seconds. The display will show a bottom LCD segment bar flash on the rightmost side of the display, for example “00.0_” and then “00.0”. See Figure 4-2.



Figure 4-2: Disabled 'No Sens' Warning

The feature can be enabled again by pressing and holding the UP key for 10 seconds. The flashing LCD segment will be turned off permanently and the 4-20 mA output will resume to track normally the display reading.

4.6 Cold Boot

When calibrating the instrument, old settings are overwritten by new values. Occasionally it may be necessary to erase contents of memory especially if the instrument has encountered a startup error. Cold booting is a method of restarting the instrument after erasing the contents of memory. Whenever a cold boot takes place, both the span and 4-20 mA output signal must be recalibrated.

CAUTION: FAILURE TO RECALIBRATE SPAN AND 4-20 mA OUTPUT AFTER PERFORMING A COLD BOOT WILL RESULT IN AN INACCURATE DISPLAY.



To perform a cold boot:

1. Power OFF the Insta Trans-XD
2. While simultaneously pressing and holding the **ENT** and **UP** keys, power the system back ON. The Insta Trans-XD will proceed through the normal startup sequence as described in

Section 3.6 but the currently stored settings in the instrument will have been erased.

3. Span calibrate the instrument as described in section 4.4.1.
4. Adjust the 4-20 mA output signal as described in Section 4.4.2.

[This page is intentionally blank]

Maintenance

5.1 Routine Maintenance

Aside from normal cleaning and checking for leaks at the gas connections, routine maintenance is limited to replacing the oxygen sensor and recalibration. For recalibration, see Section 4 *Calibration*.

WARNING: SEE WARNINGS ON THE TITLE PAGE OF THIS MANUAL.



5.2 Cell Replacement

The oxygen sensor is a sealed electrochemical transducer cell with no electrolyte to change or electrodes to clean. When the cell reaches the end of its useful life, it is replaced. The spent cell should be discarded according to local regulations. This section describes oxygen sensor care as well as when and how to replace it.

WARNING: IN ORDER TO MAINTAIN FM CERTIFICATION, THE REPLACEMENT CELL MUST BE A TELEDYNE MICRO FUEL CELL FROM THE APPROVED LIST OF SENSORS FOR THIS INSTRUMENT.



APPROVED SENSORS ARE: B1, B1C, B2C, B3, B3C, A2, A2C, A5, A5C, C5, L2C, INSTA TRACE.

REFER TO PAGE iii IN THIS MANUAL FOR THE SPECIFIC CELL USED IN THIS INSTRUMENT. SEE APPENDIX FOR TELEDYNE PART NUMBER.

5.2.1 Storing and Handling Replacement Cells

To have a replacement sensor available when it is needed, TAI recommends that one spare cell be purchased a few months after

commissioning the Insta Trans-XD, or shortly before the end of the cell's warranty period.

CAUTION: DO NOT STOCKPILE CELLS. THE WARRANTY PERIOD STARTS ON THE DAY OF SHIPMENT.



The spare sensor should be carefully stored in an area that is not subject to large variations in ambient temperature (75 °F nominal) or to rough handling.

Warning: *The sensor used in the Insta Trans-XD Trace Oxygen Transmitter uses electrolytes which contain toxic substances, mainly lead and potassium hydroxide, which can be harmful if touched, swallowed, or inhaled. Avoid contact with any fluid or powder in or around the unit. What may appear to be plain water could contain one of these toxic substances. In case of eye contact, immediately flush eyes with water for at least 15 minutes. Call physician. (see Appendix, Material Safety Data Sheet.)*



CAUTION: DO NOT DISTURB THE INTEGRITY OF THE CELL PACKAGE UNTIL THE CELL IS TO ACTUALLY BE USED. IF THE CELL PACKAGE IS PUNCTURED AND AIR IS PERMITTED TO ENTER, THE TRACE OXYGEN CELL WILL REQUIRE AN EXCESSIVELY LONG TIME TO REACH ZERO AFTER INSTALLATION (1-2 WEEKS!).



5.2.2 When to Replace a Cell

The characteristics of the sensor which is a micro-fuel cell, show an almost constant output throughout its useful life and then falls off sharply towards zero at the end. Cell failure in the Insta Trans-XD is usually characterized by the inability to span or excessive offset when used on low ppm ranges. Before replacing the cell:

1. Check your span gas to make sure it is within specifications.
2. Check for leaks downstream from the cell, where oxygen may be leaking into the system.

If there are no leaks and the span gas is OK, replace the cell.

5.2.3 Removing the Oxygen Sensor

Remove the cell holder by holding the bottom in place and unscrewing the collar until the cell holder falls out with the sensor. Remove the new sensor cell from its package, and carefully remove the shorting clip. Place the sensor on the cell holder with the screen side facing down and tighten the cell holder onto the instrument. See Figure 5-1.

5.2.4 Cell Warranty

The Insta-Trace cell is the standard trace sensor for the Insta Trans-XD. It is suitable for use in applications where the O₂ level is being measured on a ppm range. The warranty period of the Insta-Trace is six months from the date of shipment. This sensor has a life expectancy of eight months when used in trace measurement applications.

The B1C cell is the standard percent sensor for use with Insta Trans-XD. It is suitable for use when the analyzer will be used on a percent range. The B1C has a warranty period of six months from the date of shipment and a life expectancy of eight months in air.

The A2C cell is recommended for use in trace applications where CO₂ is a major component of the sample gas. The warranty period of the A2C is six months from the date of shipment. This sensor has a life expectancy of eight months when used in trace measurement applications.

The optional A5 sensor is used for intermittent or continuous monitoring of percent O₂ levels in gas mixtures containing 0-100% CO₂. It has a 90% response time of 45 seconds. The A5 sensor has more tolerance to exposure to air than other sensors in its class and it can be calibrated with air. There are no restrictions on the CO₂ concentration in the sample gas. It has a warranty of six months.

The optional Class L2C Micro-fuel Cell can be used in the Insta Trans-XD. This cell is a long life cell for use in trace (ppm) applications and is warranted for 1 year from the date of shipment. Note any Addenda attached to the front of this manual for special information applying to your instrument.

With regard to spare cells, warranty period begins on the date of shipment. The customer should purchase only one spare cell (per section 5.2.1). Do not attempt to stockpile spare cells.

The B1, B2C, Insta-Trace, and L2C cells **are not designed for applications where CO₂ is a major component in the sample**, however intermittent concentrations of 1,000 ppm or less will not adversely affect the cell performance. Consult TAI for available options for either intermittent or continuous CO₂ exposure.

The A2C cell is recommended for trace applications when the sample gas contains significant levels of CO₂. The A2C cell is suitable for CO₂ concentration of 0 to 100%.

If a cell was working satisfactorily, but ceases to function before the warranty period expires, the customer will receive credit toward the purchase of a new cell.

If you have a warranty claim, you must return the cell in question to the factory for evaluation. If it is determined that failure is due to faulty workmanship or material, the cell will be replaced at no cost to you.

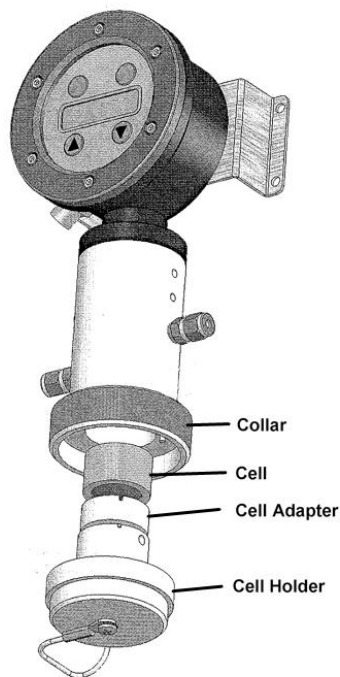

Figure 5-1: Cell Removal

5.3 Insta-Trace Sensor

Teledyne's patented Insta-Trace Sensor provides rapid sensor installation recovery time. The Insta-Trace system allows a new sensor to be installed and working at low ppm (parts per million) in a matter of minutes. The Insta-Trace option includes the Insta-Trace Sensor and a special Insta-Trace cell holder (the B2 cell adapter is not used).

Any Insta Trans-XD can be converted to an Insta-Trace by substituting the sensor and cell holder (see *Spare Parts Listing* in the Appendix).

The Insta-Trace system works by shielding the sensing membrane from air during the installation process. These special cells have an outer membrane which seals the sensing membrane in a bath of N₂ until the membrane is punctured during the installation. External gas can reach the sensing membrane only after the external membrane is pierced. This process prevents air from contaminating the sensor during installation thus allowing rapid recovery to low ppm levels. For best results, the proper installation must be followed.

To install the Insta-Trace:

- The Insta Trans-XD transmitter must be purged with sample gas at a flow rate of approximately 0.1 slpm (0.2 SCFH) during installation.
- Remove the Insta-Trace cell holder by unscrewing the collar (see Figure 5-2).
- Remove the Insta-Trace sensor from the double bags.
- Remove the shorting plug from the rear of the sensor.
- Install the sensor in the transmitter with the contact surface (two concentric gold circles) facing up, and the membrane facing down toward the cell holder.
- Orient the cell holder to align the registration pin with the hole in the cell holder.
- Push the cell holder firmly in place while rotating the collar (see Figure 5-2). The collar should be tightened finger-tight only.

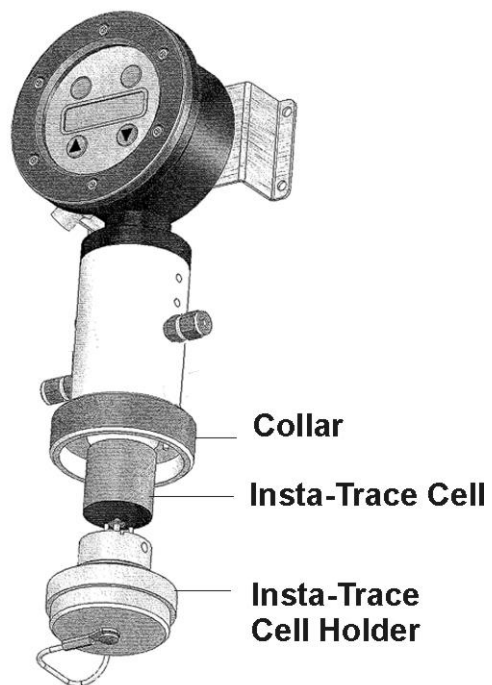

Figure 5-2: Cell Removal Insta-Trace

Appendix

Specifications

Certification: ATEX

Baseefa 12ATEX0114X

IECExBAS 12.0078X



II 1G

Ex ia IIC T4 Ga

CE 1180

Standards: EN 60079-0 :2012
IEC 60079-0 :2011
EN 60079-11:2012
IEC 60079-11:2011

Certification: FMTAI Model Insta Trans-XD IS Ex ia
CL I, Div 1, Gp ABCD T4 @ Ta= 0°C to
50°CTAI Model Insta Trans-XD Nonincendive
for CL I, Div 2, Gp ABCD T4 @ Ta= 0°C
to 50°C

Standards: FM3600:2011, FM3610:2010
FM3611:2004, FM3810:2005
CAN C22.2 No. 157: 2012
CAN C22.2 No. 213:2013
C22.2 No. 1010.1:2004
CAN/CSA 60079-0:2011
CAN/CSA 60079-11:2014

- System Enclosure:** Weather resistant, bulkhead mounted
- Power Requirements:** 9.0VDC-24VDC reverse polarity protected. V_{\min} dependent upon safety barrier and/or load resistor used.
- Electrical Input Parameters:
- $U_i = 28V$
 $I_i = 93mA$
 $P_i = 0.66W$
 $C_i = 1.1 \text{ nF}$
 $L_i = 0$
- For ATEX Approved Intrinsically Safe Operation, an approved safety barrier must be used. Ref. D86181
- For FM Nonincendive requirements, connection to equipment must be through Nonincendive Field Wiring with following parameters:
- $V_{oc} < 30 \text{ volts}$
 $L < 100 \text{ mH}$
 $C < 3 \text{ uF}$
- Ranges:** User defined from 0-10 ppm through 0–25% Oxygen (sensor dependent)
- Flow Rate:** 1-2 slpm (2.12-4.24 scfh)
- Accuracy:** $\pm 1\%$ of full scale at constant temperature and pressure (at the temperature and pressure of calibration).
 $\pm 5\%$ of full scale over operating temperature range (once thermal equilibrium has been reached), except ± 1 ppm on 0–10 ppm range.
- Response Time (90%):** Sensor Response Time + Electronic Response Time = 40 seconds @ 77°F (25°C)—(with standard cell)
- Operating Temperature:** 32–104°F (0–40°C)

Relative Humidity: 0-100% RH.

Stability: $\pm 1\%$ in 24 hours (at constant temperature)

Reproducibility: $\pm 1\%$ of full scale (at constant temperature)

Sensor Type: Micro-fuel Cell class B2C, L2C, B1, A2C, A5, Insta-Trace

Signal Output: 4–20 mA DC

Recommended Spare Parts List

| Qty. | Part Number | Description |
|------|-------------|--|
| 1 | B617 | IS Safety Barrier MTL 7787+ |
| 1 | B616 | IS Safety Barrier MTL 787S+ |
| 1 | B604 | IS Safety Barrier(Galvanic MTL 5041) |
| 1 | B49 | IS Safety Barrier MTL 5541 |
| 1 | B50 | IS Safety Barrier MTL 4541 |
| 1 | B70986 | Standard Cell Holder |
| 1 | B71625A | Interconnection Cable Assembly (24") |
| 1 | B71625D | Interconnection Cable Assembly (25 ft) |
| 1 | B66378 | Cell Adapter (B1, B2C, A2C) Insta-Trace Option |
| 1* | C6689-B2C | B2C Micro-fuel Cell |
| 1* | C6689-A5 | A5 Micro-fuel Cell |
| 1* | C6689-B1 | B1 Micro-fuel Cell |
| 1* | C6689-L2C | L2C Trace Oxygen Micro-fuel Cell |
| 1* | C6689-A2C | A2C Trace Oxygen Micro-fuel Cell |
| 1* | B71875 | Insta-Trace Sensor |
| 1 | CP2070 | Connector, Power Signal |
| 2 | O290 | O-Rings |
| 1 | B72087 | Insta-Trace Cell Holder |

* Order only one. See page iii for specific sensor used in your instrument.

Note: Orders for replacement parts should include the part number (if available) and the model and serial number of the instrument for which the parts are intended.

Orders should be sent to:

Teledyne Analytical Instruments

16830 Chestnut Street
City of Industry, CA 91748

Phone (626) 934-1500, Fax (626) 961-2538

Web: www.teledyne-ai.com
or your local representative.

Drawings

| | |
|--------|---|
| C83162 | Outline Drawing |
| B71625 | Interconnection Diagram, Cable |
| D86181 | Interconnection Diagram, with Safety Barriers |
| D92719 | Interconnection Diagram (FM) |

NOTES: UNLESS OTHERWISE SPECIFIED.

1. CUT 22 AWG 2 CONDUCTOR SHIELDED CABLE TO LENGTH SPECIFIED.

| OPTION | X DIMENSION |
|--------|-------------|
| A | 24 INCH |
| B | 48 INCH |
| C | 10 FEET |
| D | 25 FEET |

2. USE TORQUE WRENCH SET AT 2 IN. LBS. ON THE WIRE SCREWS.

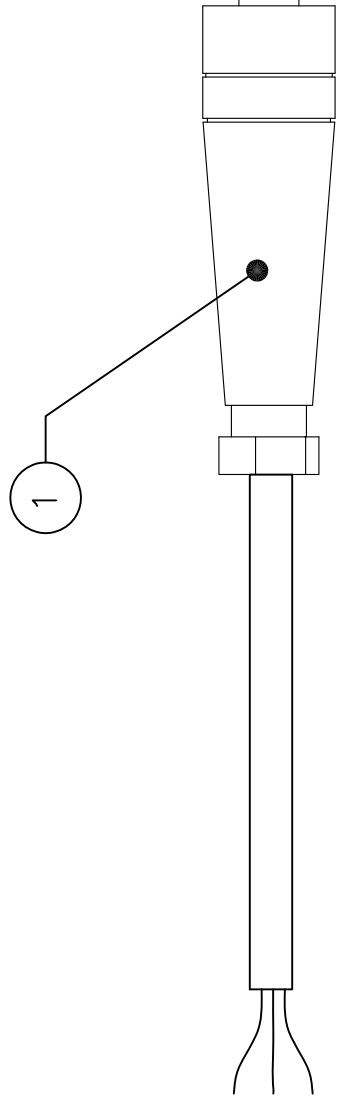
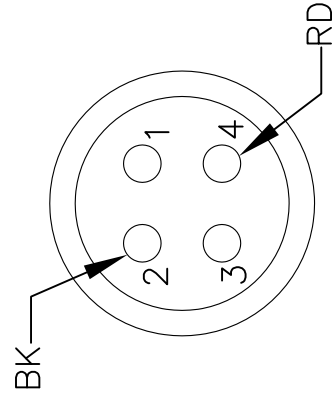
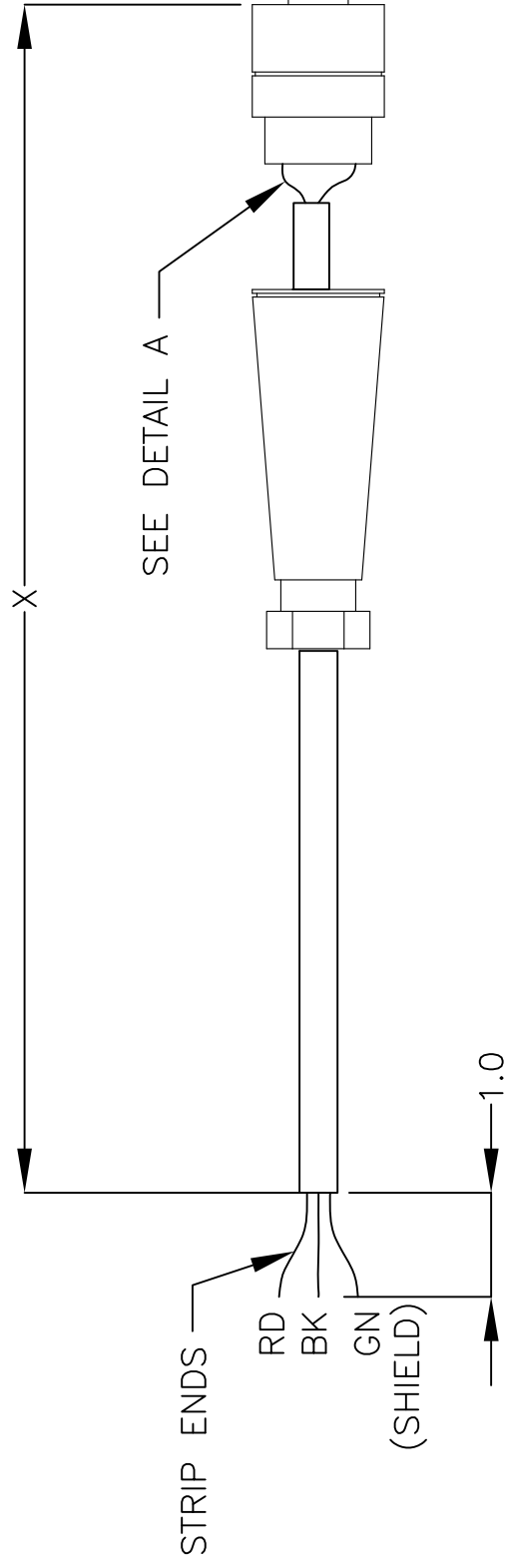

REVISIONS

| REV. | DESCRIPTION | DATE | APP. | REV. BY |
|------|----------------------|----------|------|---------|
| 1 | INC PER ECO# 00-0300 | 09/05/00 | KFP | -- |
| 2 | INC PER ECO# 00-0418 | 12/18/00 | KFP | JCR |
| 3 | INC PER ECO# 13-0042 | 4/25/13 | AA | VF |
| 4 | INC PER ECO14-0101 | 5/11/15 | AA | VF |

| | | | |
|------|------|-----------|------------------|
| 2 | REF | B71625-RS | ROUTE SHEET |
| 1 | | CP 2070 | CONNECTOR, 4 PIN |
| ITEM | QTY. | PART NO. | DESCRIPTION |

DO NOT SCALE DRAWING
TOLERANCE UNLESS OTHERWISE SPECIFIED: ANGULAR ±1/2°
LINEAR { .X = ± 0.1
.XX = ± 0.02
.XXX = ± 0.010

THIS DRAWING IS THE PROPERTY OF TELEDYNE ANALYTICAL INSTRUMENTS AND CONTAINS CONFIDENTIAL INFORMATION. IT IS NOT TO BE COPIED, REPRODUCED OR USED WITHOUT WRITTEN PERMISSION.
Teledyne Analytical Instruments
A business unit of Teledyne Instruments Inc.
CITY OF INDUSTRY, CALIFORNIA 91748, USA

| | | | | | | | |
|-------------|--------------------|-------------|--------|--------------|---|---------|---------|
| S/ B71625-2 | DRFT: JEREMY MARSH | DATE | 2/4/00 | TITLE | CONNECTOR ASSEMBLY MODEL INSTA TRANS | SCALE | 1 : 1 |
| I/ | CHK: | | | SIGNATURES | | SIM | |
| P/ | APPR: | | | JEREMY MARSH | | | |
| O/ | ENGR: | KARL PENSON | | | | | |
| F/ | S.O.: | 018414 | | | | | |
| REFERENCE | CAD I.D. | B71625-4 | | | | | |
| | | | | MATL. | SEE NOTE 1 | DWG NO. | B-71625 |
| | | | | | | SHEET | 1 OF 1 |
| | | | | | | REV | 4 |

DETAIL A
SCALE 2:1

NOTES: UNLESS OTHERWISE SPECIFIED.

1. RECOMMENDED WIRE: 20 AWG SHIELDED. CABLE LENGTH NOT TO EXCEED 5000FT (1520 METERS)
2. WARNING -- SUBSTITUTION OF COMPONENTS MAY IMPAIR INTRINSIC SAFETY.
WARNING -- TO PREVENT IGNITION OF FLAMMABLE OR COMBUSTIBLE ATMOSPHERES, READ, UNDERSTAND AND ADHERE TO MANUFACTURER'S MANUAL.
WARNING -- POTENTIAL ELECTROSTATIC CHARGING HAZARD ENCLOSURE CONTAINS EXPOSED PLASTIC. TO PREVENT THE RISK OF ELECTROSTATIC SPARKING ONLY CLEAN WITH DAMP CLOTH.

WARNING -- THE APPARATUS ENCLOSURE CONTAINS ALUMINUM AND IS CONSIDERED TO CONSTITUTE A POTENTIAL RISK OF IGNITION BY IMPACT OR FRICTION. CARE MUST BE TAKEN INTO ACCOUNT DURING INSTALLATION AND USE TO PREVENT IMPACT OR FRICTION.

3. FM HAZARDOUS LOCATION INSTALLATIONS:
LOCATIONS: CLASS I, DIVISION 1, GROUPS ABCD.
4. INSTALLATION MUST BE IN ACCORDANCE TO ANSI/ISA*RP12.05.01 "INSTALLATION OF INTRINSICALLY SAFE SYSTEM FOR HAZARDOUS (CLASSIFIED) LOCATIONS" AND THE NATIONAL ELECTRICAL CODE (ANSI/NFPA 70) AND CANADIAN ELECTRICAL CODE, CSA NO. C22.1.

5. MTL 7787, 787S, 5041, 5541 OR 4541 BARRIERS MUST BE CONNECTED TO A SUITABLE GROUND ELECTRODE PER NFPA 70, ARTICLE 504. THE RESISTANCE OF THE GROUND PATH MUST BE LESS THAN 1 OHM.

6. MODELS MTL 7787, 787S, 5041, 5541 AND 4541 BARRIERS MUST NOT BE CONNECTED TO ANY DEVICE THAT USES OR GENERATES IN EXCESS OF 250 VRMS OR DC UNLESS IT HAS BEEN DETERMINED THAT THE VOLTAGE HAS BEEN ADEQUATELY ISOLATED FROM THE BARRIER.

7. MAXIMUM RECOMMENDED CABLE LENGTH (GROUP C&D): 5000 FEET (1520 METERS).
MAXIMUM RECOMMENDED CABLE LENGTH (GROUP A&B): 1500 FEET (475 METERS)

| GAS GROUP | CAPACITANCE in uF | INDUCTANCE in mH |
|-----------|----------------------|---------------------|
| GP AB | 0.09 | 0.3 |
| GP C | 0.3 | 1 |
| GP D | 0.9 | 3 |

8. ATEX INSTALLATION:

THE CAPACITANCE AND EITHER THE INDUCTANCE OR INDUCTANCE TO RESISTANCE RATIO OF THE CABLE INTERCONNECTING THE INSTA TRANS-XD AND THE BARRIER MUST NOT EXCEED THE VALUES IN THE FOLLOWING TABLE:

| GROUP | CAPACITANCE in uF | INDUCTANCE OR L/R RATIO in uH/ohm |
|-------|----------------------|---|
| IIC | 0.072 | 3 |
| IIB | 0.238 | 9.1 |
| IIA | 0.653 | 24 |
| | | 54 |
| | | 162 |
| | | 432 |

9. THE HAZARDOUS AREA CIRCUIT MUST BE CAPABLE OF WITHSTANDING AN AC VOLTAGE TEST OF 500V R.M.S. TO EARTH/GROUND FOR ONE MINUTE.

10. THE MINIMUM SAFETY BARRIER SERIES RESISTANCE IS GREATER THAN 300 OHMS.

11. THE INSTALLATION, INCLUDING THE BARRIER EARTHING/GROUNDING ARRANGEMENT, MUST COMPLY WITH THE NATIONAL REQUIREMENTS OF THE COUNTRY OF USE (E.G. IN THE UK BS 5345: PART4: 1977 OR BS EN 60079-14).

12. THE SAFE AREA TERMINALS OF THE MTL 7787, 787S, 5041, 5541 AND 4541 BARRIERS MUST NOT BE CONNECTED TO ANY DEVICE THAT IS SUPPLIED FROM OR CONTAINS IN NORMAL OR ABNORMAL CONDITIONS, A SOURCE OF POTENTIAL WITH RESPECT TO EARTH/GROUND EXCESS OF 250 VRMS OR D.C.

13. THE SYSTEM IS TO BE MARKED IN A "STRATEGIC" POSITION WITH AT LEAST THE FOLLOWING:
BAS NUMBER EX 01E2324 SYST

14. THE CABLE SCREEN/SHIELD MUST NOT BE CONNECTED TO EARTH/GROUND IN THE HAZARDOUS AREA.

15. THE CABLE SCREEN/SHIELD MUST NOT BE CONNECTED TO THE INSTA TRANS-XD.

16. THE APPARATUS IS CAPABLE OF WITHSTANDING A 500V R.M.S. AC VOLTAGE TEST BETWEEN IT'S CIRCUIT AND IT'S ENCLOSURE FOR ONE MINUTE.

SAFE AREA

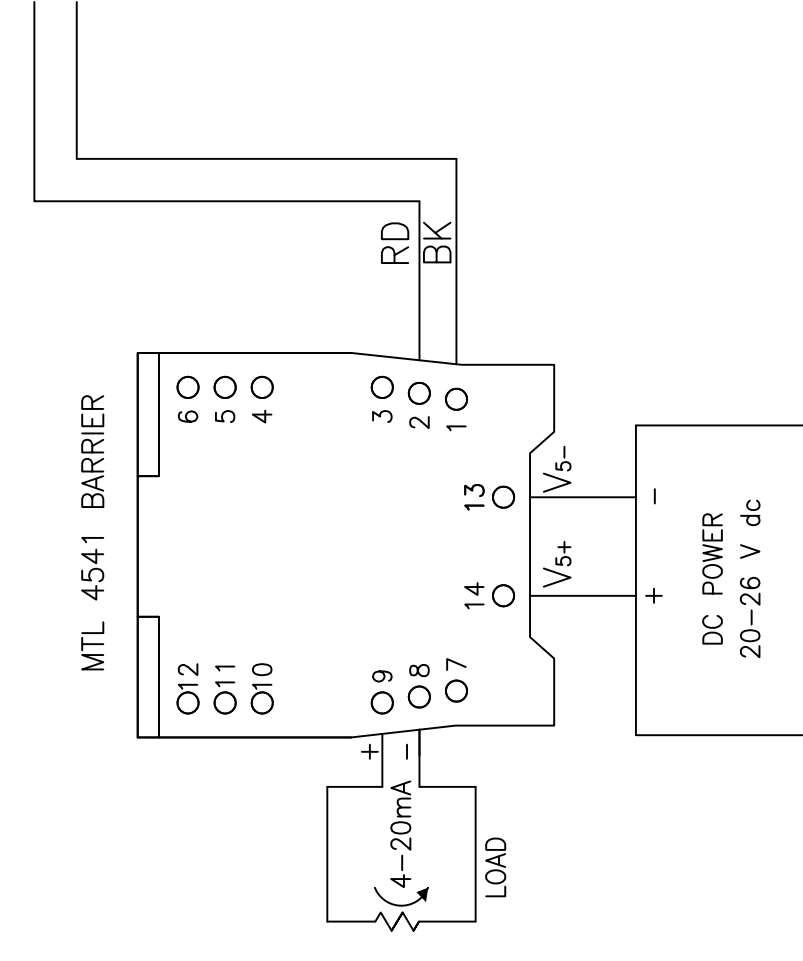
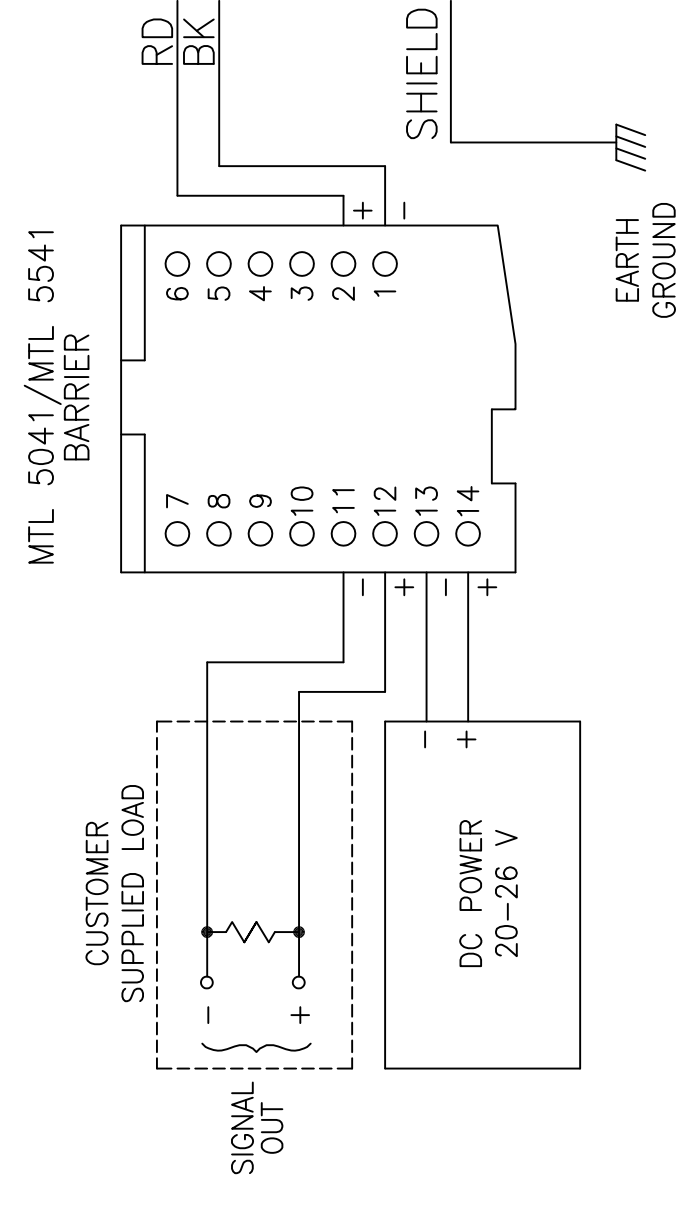
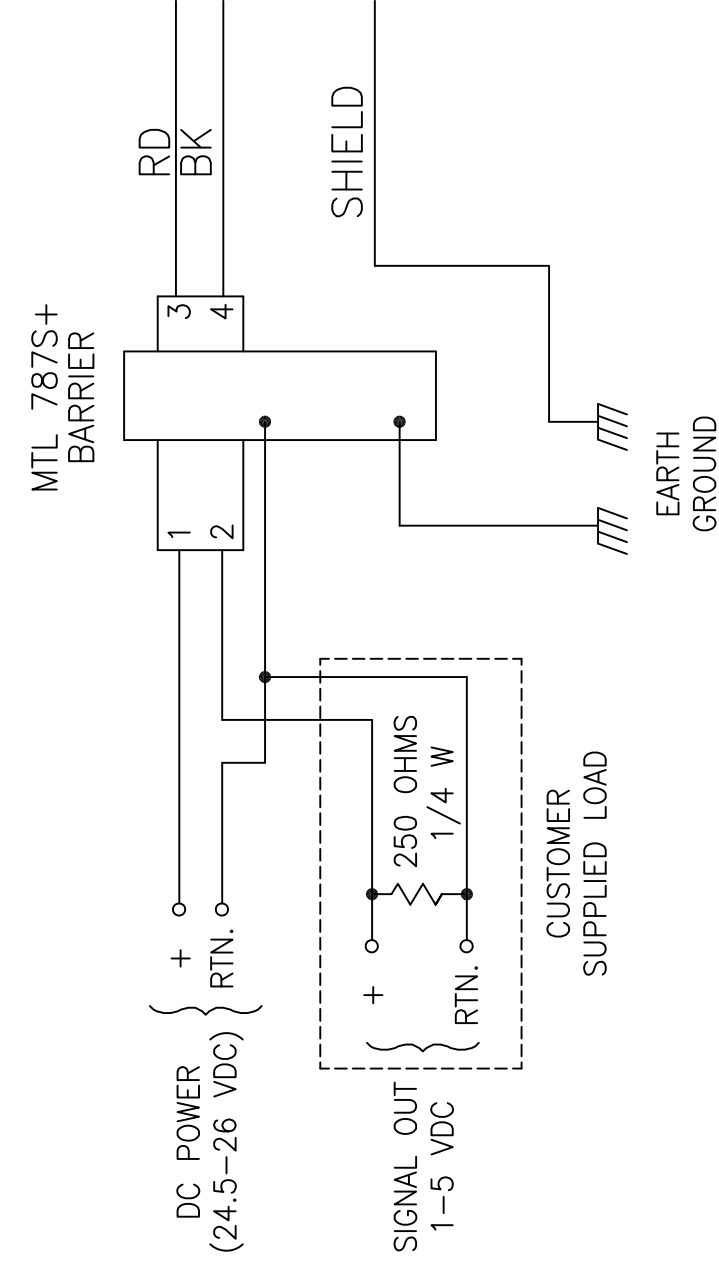
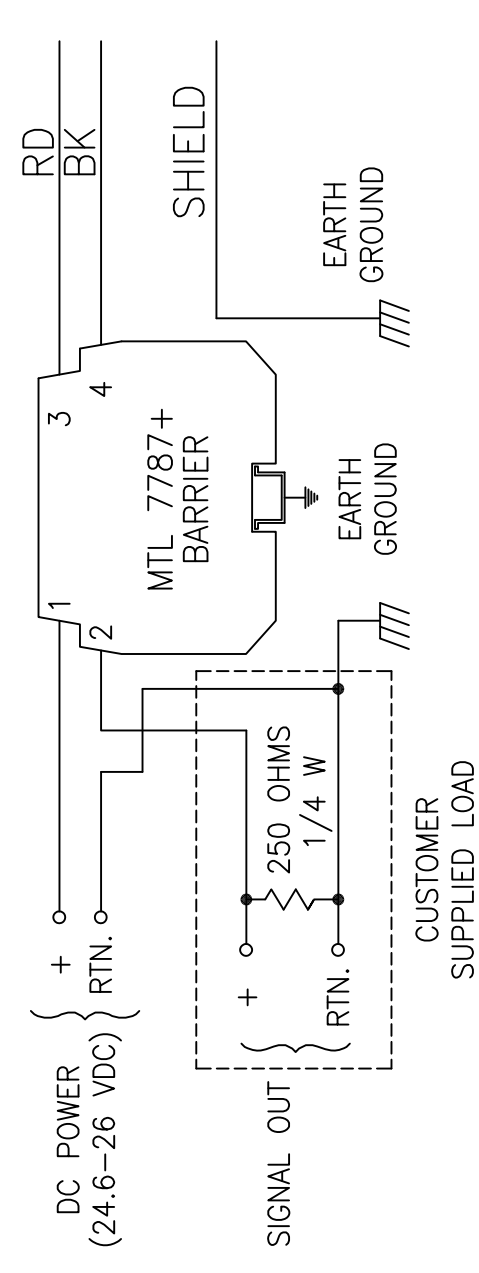

HAZARDOUS AREA

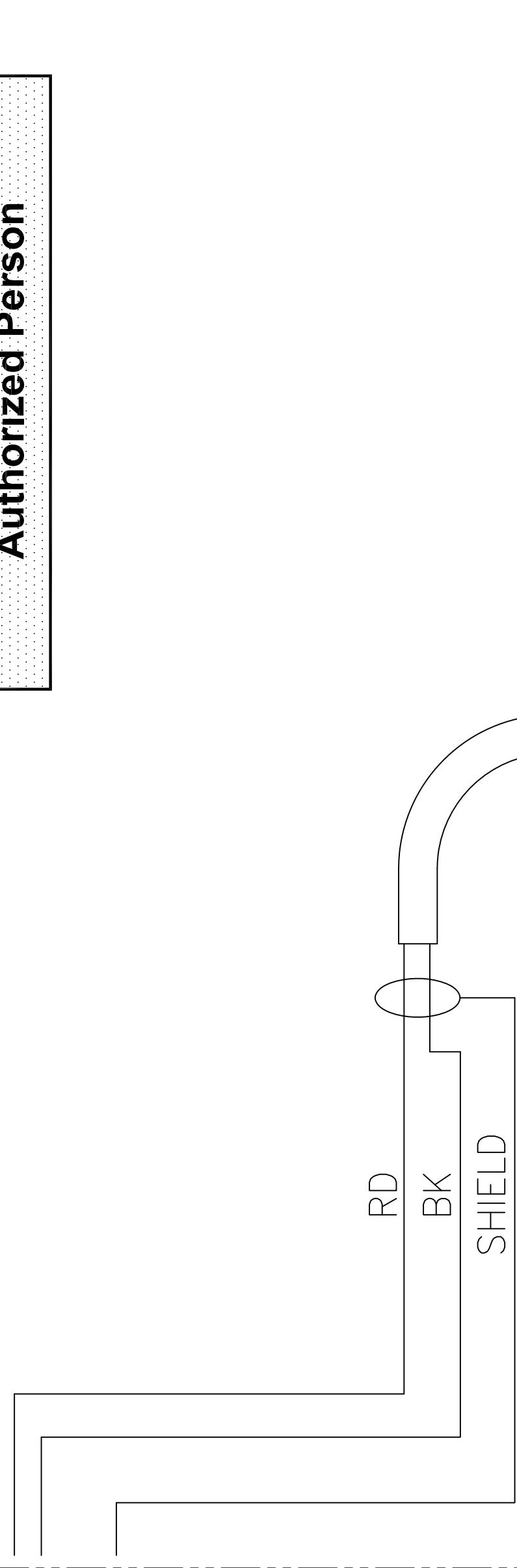

MODEL INSTA TRANS-XD

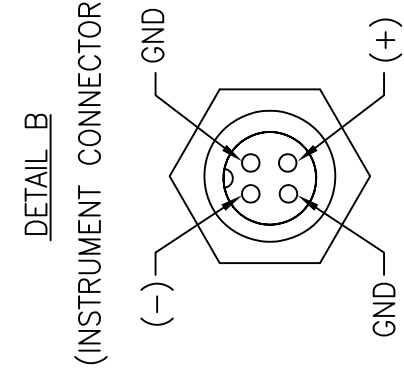
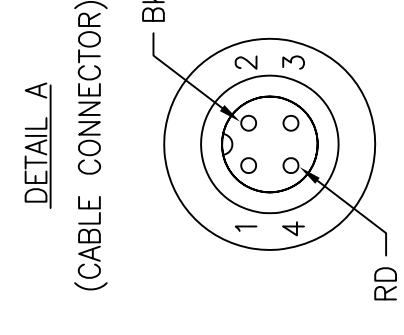
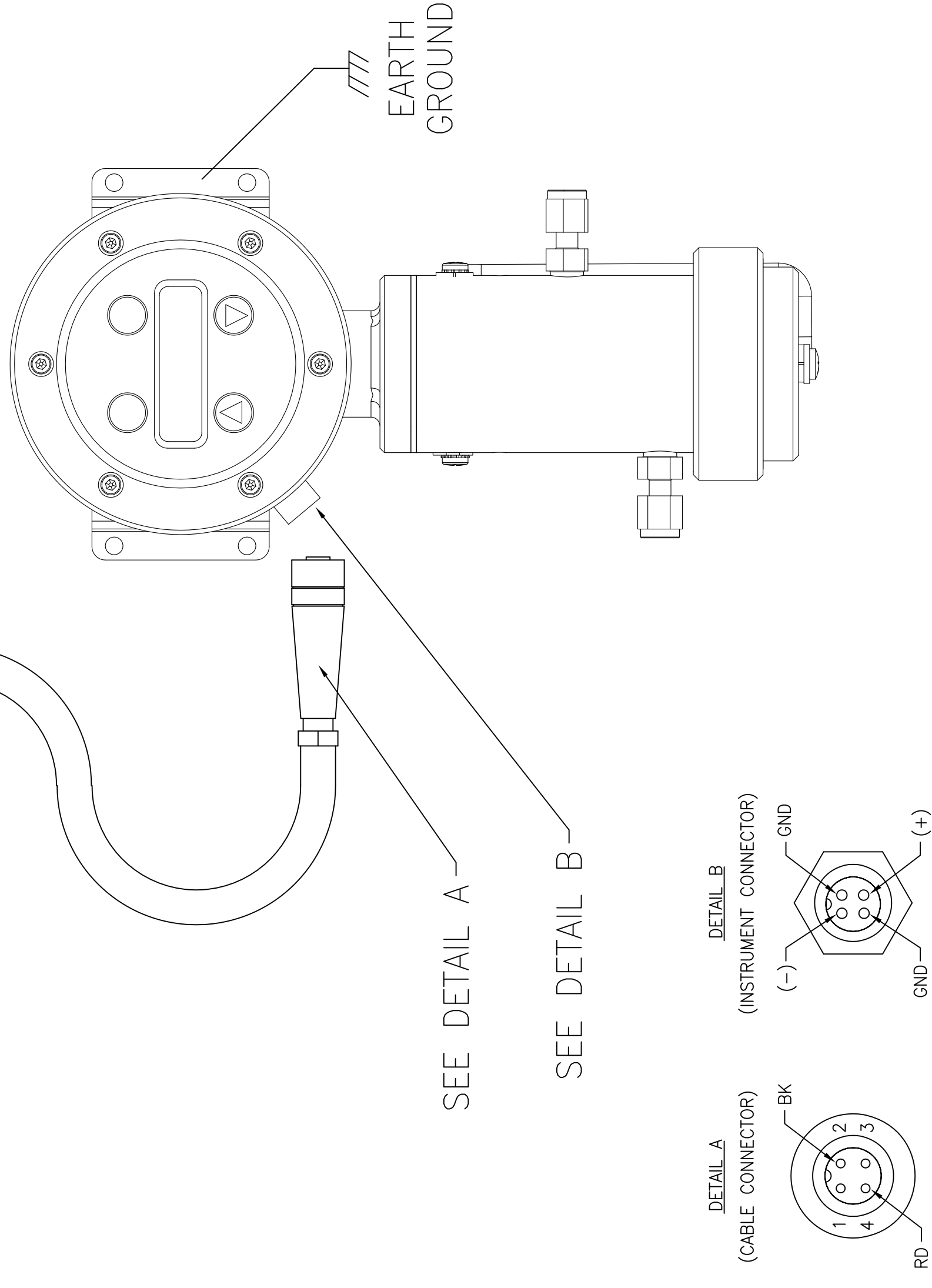

ATEX Certified Product
No modification permitted
without the approval of the
Authorized Person

| REV | DESCRIPTION | DATE | APP. | REV. |
|-----|----------------------------|---------|------|------|
| 0 | PRODUCTION RELEASE 14-0045 | 9/26/11 | KFP | -- |
| 1 | INC ECO 15-0004 | 3/6/15 | AA | VF |

REVISIONS

| ITEM | QTY | PART NO. | DESCRIPTION |
|----------------------------|----------------|-------------------------|-----------------|
| BILL OF MATERIAL | | | |
| DO NOT SCALE DRAWING | | | |
| UNLESS OTHERWISE SPECIFIED | | | |
| DIMENSIONS ARE IN INCHES | | | |
| ANGULAR ±1/2° LINEAR ±.02 | | | |
| ANGULAR ±1/2° LINEAR ±.010 | | | |
| SIGNATURES | | | |
| DRAWN: KFP | DATE: 09/26/11 | TITLE: INSTA TRANS-XD | SCALE: none |
| CHK: / | | INTERCONNECTION DIAGRAM | SIM D75226 |
| APP: / | | | SHEET 1 OF 1 |
| ENGR: KFP | | | REV 1 |
| C.O. STANDARD | | | DWG NO. D-86181 |
| CAD ID: D86181-1.dwg | | | AS LISTED |

THE DRAWING IS THE PROPERTY OF TELEONE ANALYTICAL INSTRUMENTS AND CONTAINS CONFIDENTIAL INFORMATION. IT IS NOT TO BE COPIED, REPRODUCED OR USED WITHOUT WRITTEN PERMISSION.

TELEDYNE
Analytical Instruments
A Business Unit of Teledyne Instruments, Inc.
City of Industry, California 91748, USA

| REV | DESCRIPTION | DATE | APP. | REV. |
|-----|----------------------------|---------|------|------|
| 0 | PRODUCTION RELEASE 14-0045 | 9/26/11 | KFP | -- |
| 1 | INC ECO 15-0004 | 3/6/15 | AA | VF |

NOTES: UNLESS OTHERWISE SPECIFIED.

1. RECOMMENDED WIRE: 20 AWG SHIELDED. CABLE LENGTH NOT TO EXCEED 5000FT (1520 METERS)
2. WARNING - SUBSTITUTION OF COMPONENTS MAY IMPAIR INTRINSIC SAFETY.
WARNING - TO PREVENT IGNITION OF FLAMMABLE OR COMBUSTIBLE ATMOSPHERES, READ, UNDERSTAND AND ADHERE TO MANUFACTURER'S MANUAL.
WARNING - POTENTIAL ELECTROSTATIC CHARGING HAZARD ENCLOSURE CONTAINS EXPOSED PLASTIC. TO PREVENT THE RISK OF ELECTROSTATIC SPARKING ONLY CLEAN WITH DAMP CLOTH.
WARNING - THE APPARATUS ENCLOSURE CONTAINS ALUMINUM AND IS CONSIDERED TO CONSTITUTE A POTENTIAL RISK OF IGNITION BY IMPACT OR FRICTION. CARE MUST BE TAKEN INTO ACCOUNT DURING INSTALLATION AND USE TO PREVENT IMPACT OR FRICTION.
3. FM HAZARDOUS LOCATION INSTALLATIONS:
LOCATIONS: CLASS 1, DIVISION 1, GROUPS ABCD.
LOCATIONS: CLASS 1, DIVISION 2, GROUPS ABCD.
4. THE CABLE SCREEN/SHIELD MUST NOT BE CONNECTED TO EARTH/GROUND IN THE HAZARDOUS AREA.
5. THE CABLE SCREEN/SHIELD MUST NOT BE CONNECTED TO THE INSTA TRANS-XD.

6. MAXIMUM RECOMMENDED CABLE LENGTH (GROUP C&D): 5000 FEET (1520 METERS).
MAXIMUM RECOMMENDED CABLE LENGTH (GROUP A&B): 1500 FEET (475 METERS)

| MAXIMUM ACCEPTABLE CABLE CAPACITANCE AND INDUCTANCE. | | | |
|--|----------------------|---------------------|---|
| GAS GROUP | CAPACITANCE in uF | INDUCTANCE in mH | |
| GP AB | 0.09 | 0.3 | 1 |
| GP C | 0.3 | | 3 |
| GP D | 0.9 | | |

7. INSTALLATION SHOULD BE IN ACCORDANCE WITH ANSI/ISA RP12.06.01 "Installation of Intrinsically safe Systems for Hazardous (Classified) Locations" AND THE NATIONAL ELECTRICAL CODE®(ANSI/NFPA 70)
8. INSTALLATION IN CANADA SHOULD BE IN ACCORDANCE WITH THE CANADIAN ELECTRICAL CODE, CSA C22.1, PART 1 APPENDEX F.

9. NO REVISION TO THIS DRAWING IS PERMITTED WITHOUT PRIOR FM REVIEW APPROVAL OF THE CHANGES.

10. V_{max} or $U_i \geq V_t$; I_{max} or $I_i \geq I_t$; (C_i of all loops + C_{cable}) $\leq C_a$ or C_o ;
(L_i of all loops + L_{cable}) $\leq L_a$ or L_o ; P_{max} or $P_i \geq P_o$

11. To meet Nonincendive requirements, connection to equipment must be through Nonincendive Field Wiring. Nonincendive Field parameters:

$V_i < 28$ volts
 $I_i < 27$ ma
 $P_i = 0.66$ W
 $C_i = 1.1$ nF
 $L_i = 0$

NON HAZARDOUS LOCATION

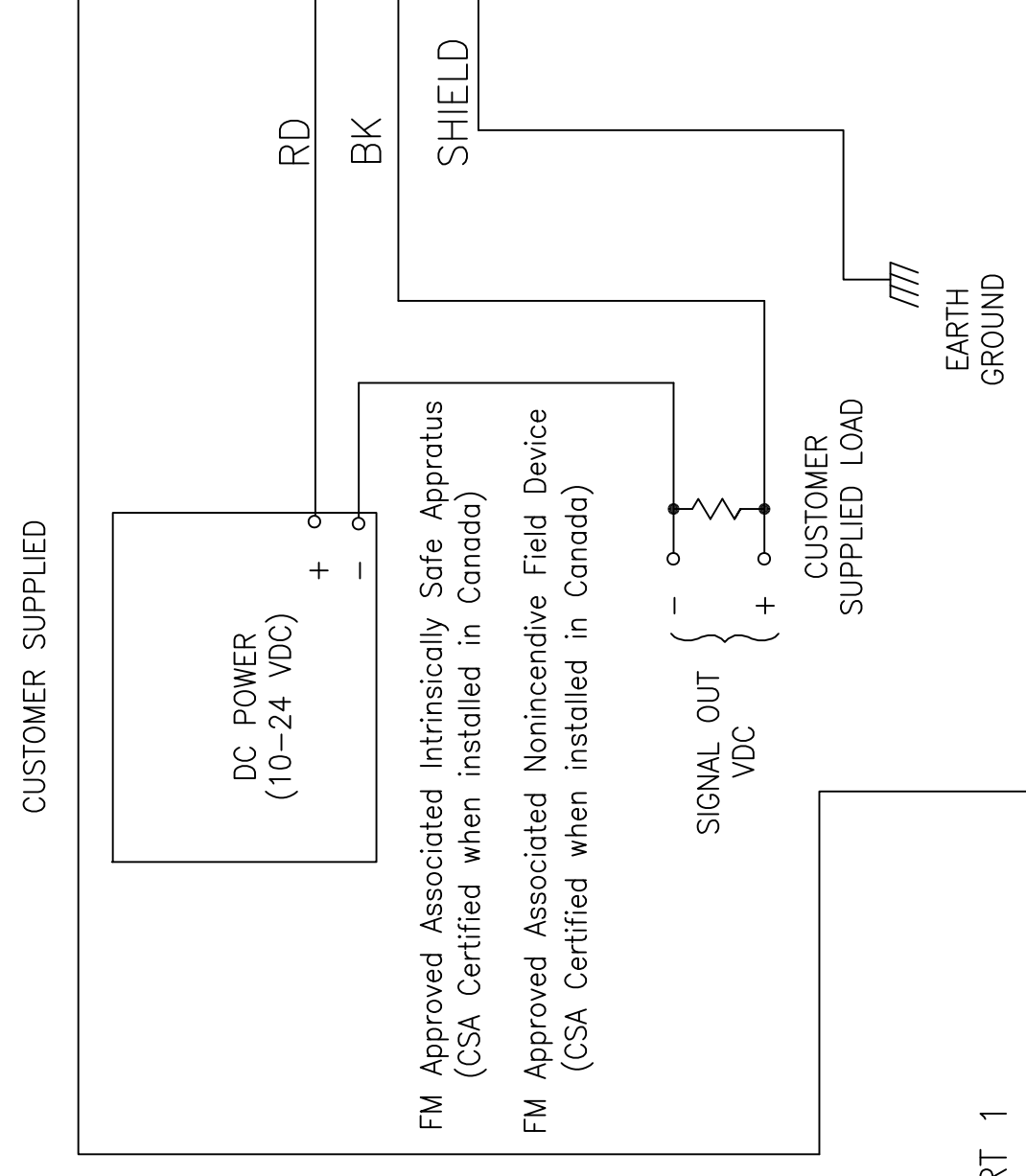

HAZARDOUS AREA LOCATION

Class I, Division 1, Groups A,B,C and D
 Class I, Division 2, Groups A,B,C and D
 Class I, Zone 1, Ex ia IIC

INSTA TRANS-XD I.S. Entity Parameters

$U_i = 28$ VDC
 $I_i = 93$ mA
 $P_i = 0.66$ W
 $C_i = 1.1$ nF
 $L_i = 0$

INSTA TRANS-XD Nonincendive Field Wiring Parameters

$V_i < 28$ volts
 $I_i < 27$ ma
 $P_i = 0.66$ W
 $C_i = 1.1$ nF
 $L_i = 0$

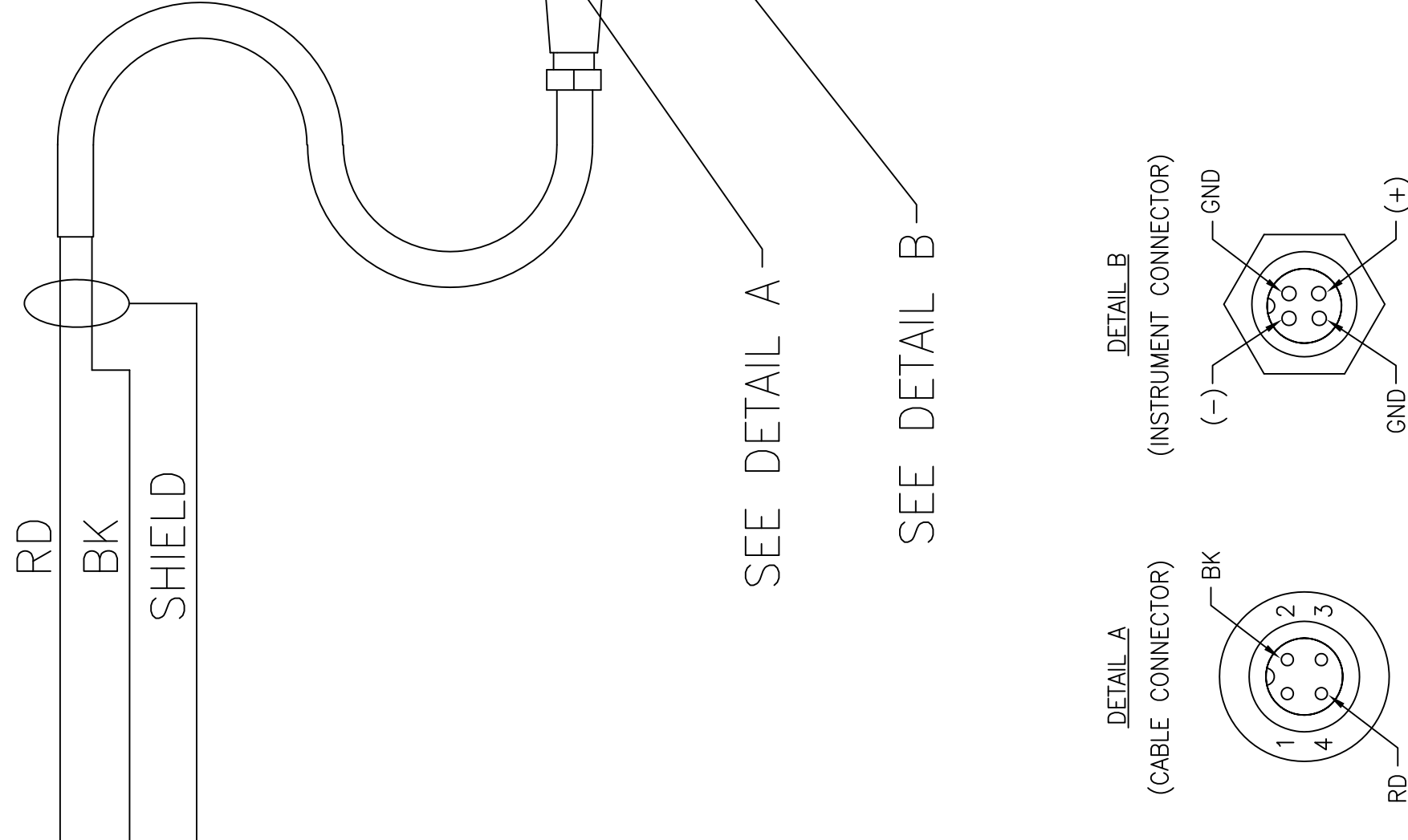

SEE DETAIL A

SEE DETAIL B

MODEL INSTA TRANS-XD

CABLE CAPACITANCE AND INDUCTANCE PER FOOT

| GAS GROUP | CAPACITANCE in pF/Ft | INDUCTANCE in uH/Ft |
|-----------|-------------------------|------------------------|
| GP AB | 60 | 0.2 |
| GP C | 60 | 0.2 |
| GP D | 180 | 0.6 |

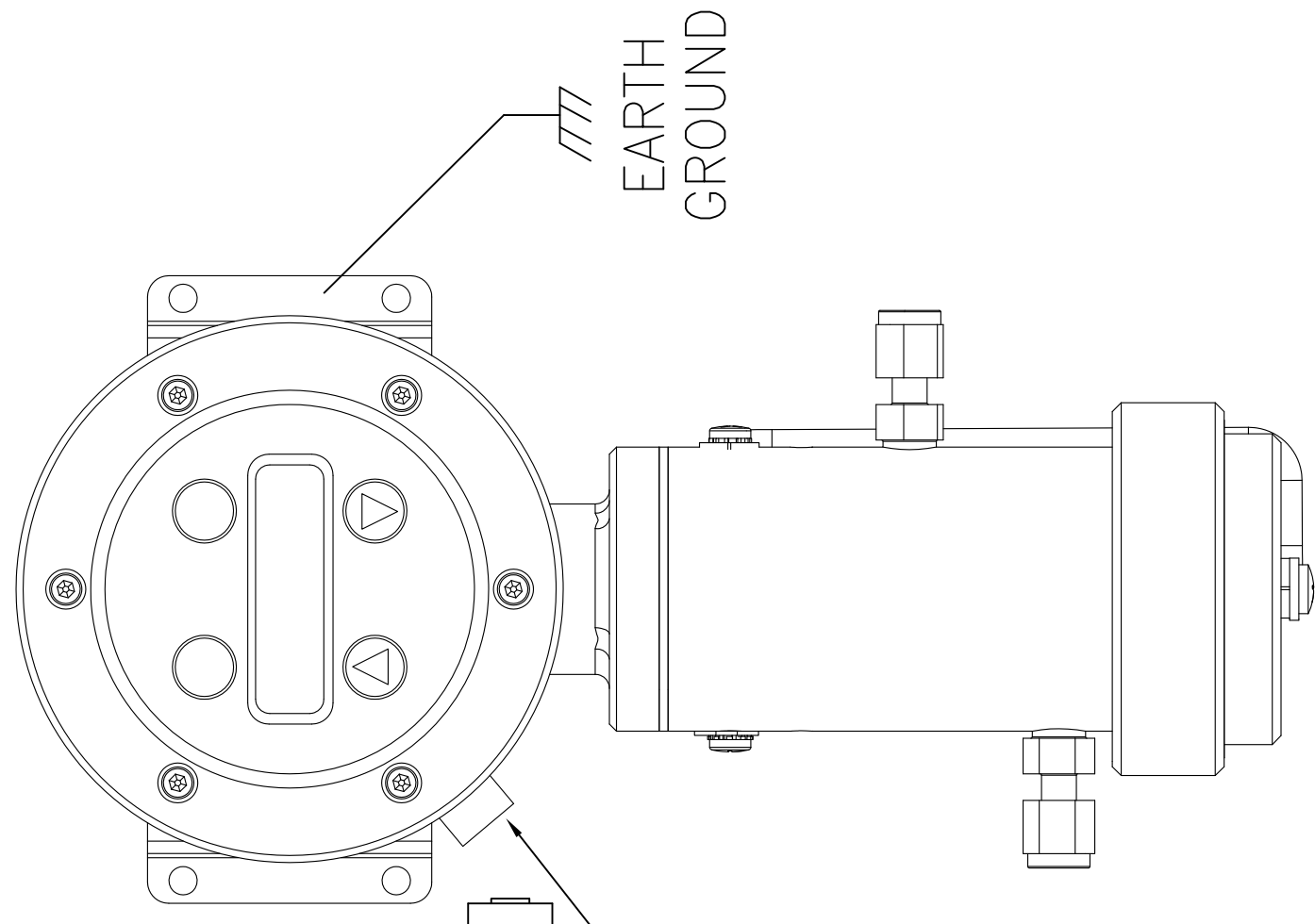

EARTH
GROUND

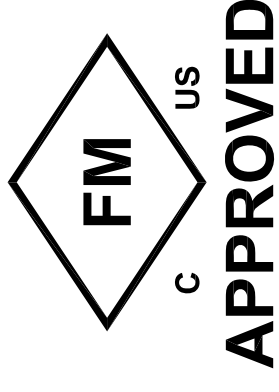

| REV | DESCRIPTION | DATE | APP. | REV. |
|-----|----------------------------|---------|------|------|
| 0 | PRODUCTION RELEASE 16-0007 | 4/29/15 | KFP | -- |

| ITEM | QTY | PART NO. | DESCRIPTION |
|---|---------------------|-----------------|--------------|
| BILL OF MATERIAL | | | |
| DO NOT SCALE DRAWING UNLESS OTHERWISE SPECIFIED DIMENSIONS ARE IN INCHES TOLERANCES: FRACTIONS = ±.1 DECIMALS = ±.005 ANGULAR ±1/2° LINEAR ±.010 HOLE DIA ±.010 | | | |
| TELEDYNE Analytical Instruments A Business Unit of Teledyne Instruments, Inc. City of Industry, California 91748, USA | | | |
| SIGNATURES | | | TITLE |
| DRET: KFP | | 04/29/15 | SCALE |
| CHK: | | | none |
| APPRE: | | | SIM D86181 |
| ENGR: KFP | | | SHEET 1 OF 1 |
| F/ CB2620 | | | REV 0 |
| REFERENCE | CAD ID D92719-0.dwg | | |
| | AS LISTED | DWG NO. D-92719 | |

| REV | DESCRIPTION | DATE | APP. | REV. |
|-----|----------------------------|---------|------|------|
| 0 | PRODUCTION RELEASE 16-0007 | 4/29/15 | KFP | -- |

| REV | DESCRIPTION | DATE | APP. | REV. |
|-----|----------------------------|---------|------|------|
| 0 | PRODUCTION RELEASE 16-0007 | 4/29/15 | KFP | -- |

1

2

3

4

NOTES: UNLESS OTHERWISE SPECIFIED.

- 1. ALL DIMENSIONS ARE IN INCHES (+/-0.06) AND MILLIMETERS [] (+/-1) mm
- 2. THE OUTPUT OF THE O2 SENSOR INSTALLED IN THIS ANALYZER SHALL NOT EXCEED 1.4 MADC, & 1.0 VDC @ 50°C (MAXIMUM OPERATING TEMPERATURE).

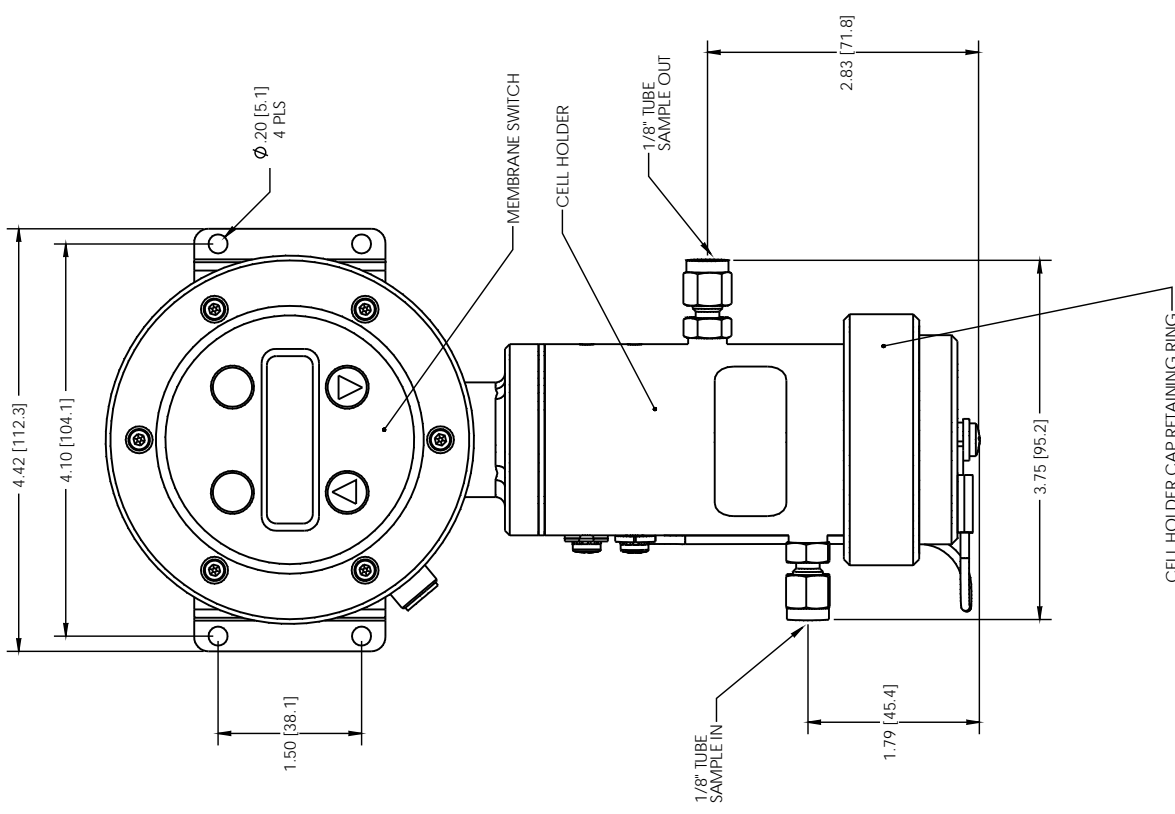

| REV | DESCRIPTION | DATE | APP | REV |
|-----|-------------------|----------|-----|-----|
| 0 | INITIAL RELEASE | 11/09/12 | KFP | - |
| 1 | UPDATED TITLE | 4/14/14 | KFP | KFP |
| 2 | UPDATE DIMENSIONS | 8-20-15 | KFP | KFP |
| 3 | UPDATE DIMENSIONS | 10-3-16 | KFP | KFP |

| BILL OF MATERIALS | | TITLE | | SCALE |
|---|---------------|--|--|--------|
| DO NOT SCALE DRAWING | | Teledyne Analytical Instruments | | 1:1 |
| TOLERANCE UNLESS OTHERWISE SPECIFIED: ANGULAR ±1/2° | | A business of Teledyne Electronic Technologies | | SIM |
| LINEAR: X ± 0.1, Y ± 0.1, Z ± 0.010 | | CITY OF INDUSTRY, CALIFORNIA 91788 | | SHEET |
| SIGNATURES | | DRAWING NO. | | 1 OF 1 |
| DRAWN: KFP | DATE: 4/14/14 | C-83162 | | REV |
| CHECK: | | | | 3 |
| APPRE: | | | | |
| ENGINEER: KFP | | | | |
| STANDARD: | | | | |
| REFERENCE: | | | | |

1

2

3

4

D

C

B

A