

Use and Disclosure of Data
Information contained herein is classified as EAR99 under the
U.S. Export Administration Regulations.
Export, reexport or diversion contrary to U.S. law is prohibited.

INSTRUCTIONS FOR

Model TCA330

Total Chlorine Analyzer



P/N MTCA330
Date 10/16/18



DANGER



Toxic gases and or flammable liquids may be present in this instrument.
Personal protective equipment may be required when servicing this instrument.

Hazardous voltages exist on certain components internally which may persist for a time even after the power is turned off and disconnected.

Only authorized personnel should conduct maintenance and/or servicing.
Before conducting any maintenance or servicing, consult with authorized supervisor/manager.

Copyright © 2018 Teledyne Instruments/ Analytical Instruments

All Rights Reserved. No part of this manual may be reproduced, transmitted, transcribed, stored in a retrieval system, or translated into any other language or computer language in whole or in part, in any form or by any means, whether it be electronic, mechanical, magnetic, optical, manual, or otherwise, without the prior written consent of Teledyne Instruments/ Analytical Instruments, 16830 Chestnut Street, City of Industry, CA 91748.

Warranty

This equipment is sold-subject to the mutual agreement that it is warranted by us free from defects of material and of construction, and that our liability shall be limited to replacing or repairing at our factory (without charge, except for transportation), or at customer plant at our option, any material or construction in which defects become apparent within one year from the date of shipment, except in cases where quotations or acknowledgements provide for a shorter period. Components manufactured by others bear the warranty of their manufacturer. This warranty does not cover defects caused by wear, accident, misuse, neglect or repairs other than those performed by TI/AI or an authorized service center. We assume no liability for direct or indirect damages of any kind and the purchaser by the acceptance of the equipment will assume all liability for any damage which may result from its use or misuse.

We reserve the right to employ any suitable material in the manufacture of our apparatus, and to make any alterations in the dimensions, shape or weight of any parts, in so far as such alterations do not adversely affect our warranty.

Important Notice

This instrument provides measurement readings to its user, and serves as a tool by which valuable data can be gathered. The information provided by the instrument may assist the user in eliminating potential hazards caused by his process; however, it is essential that all personnel involved in the use of the instrument or its interface, with the process being measured, be properly trained in the process itself, as well as all instrumentation related to it.

The safety of personnel is ultimately the responsibility of those who control process conditions. While this instrument may be able to provide early warning of imminent danger, it has no control over process conditions, and it can be misused. In particular, any alarm or control systems installed must be tested and understood, both as to how they operate and as to how they can be defeated. Any safeguards required such as locks, labels, or redundancy, must be provided by the user or specifically requested of TI/AI at the time the order is placed.

Therefore, the purchaser must be aware of the hazardous process conditions. The purchaser is responsible for the training of personnel, for providing hazard warning methods and instrumentation per the appropriate standards, and for ensuring that hazard warning devices and instrumentation are maintained and operated properly.

Teledyne Instruments/ Analytical Instruments, the manufacturer of this instrument, cannot accept responsibility for conditions beyond its knowledge and control. No statement expressed or implied by this document or any information disseminated by the manufacturer or its agents, is to be construed as a warranty of adequate safety control under the user's process conditions.

Specific Model Information

Instrument Serial Number: _____

Safety Messages

Your safety and the safety of others is very important. We have provided many important safety messages in this manual. Please read these messages carefully.

A safety message alerts you to potential hazards that could hurt you or others. Each safety message is associated with a safety alert symbol. These symbols are found in the manual and inside the instrument. The definition of these symbols is described below:



GENERAL WARNING/CAUTION: Refer to the instructions for details on the specific danger. These cautions warn of specific procedures which if not followed could cause bodily Injury and/or damage the instrument.



CAUTION: HOT SURFACE WARNING: This warning is specific to heated components within the instrument. Failure to heed the warning could result in serious burns to skin and underlying tissue.



WARNING: ELECTRICAL SHOCK HAZARD: Dangerous voltages appear within this instrument. This warning is specific to an electrical hazard existing at or nearby the component or procedure under discussion. Failure to heed this warning could result in injury and/or death from electrocution.



Technician Symbol: All operations marked with this symbol are to be performed by qualified maintenance personnel only.

No
Symbol

NOTE: Additional information and comments regarding a specific component or procedure are highlighted in the form of a note.

CAUTION: THIS INSTRUMENT SHOULD ONLY BE USED FOR THE PURPOSE AND IN THE MANNER DESCRIBED IN THIS MANUAL.



IF YOU USE THIS EQUIPMENT IN A MANNER OTHER THAN THAT FOR WHICH IT WAS INTENDED, UNPREDICTABLE BEHAVIOR COULD RESULT POSSIBLY ACCOMPANIED WITH HAZARDOUS CONSEQUENCES.

This manual provides information designed to guide you through the installation, calibration operation and maintenance of your new analyzer. Please read this manual and keep it available.

Occasionally, some instruments are customized for a particular application or features and/or options added per customer requests. Please check the front of this manual for any additional information in the form of an Addendum which discusses specific information, procedures, cautions and warnings that may be peculiar to your instrument.

Manuals do get lost. Additional manuals can be obtained from TI/AI at the address given in the Appendix. Some of our manuals are available in electronic form via the internet. Please visit our website at: www.teledyne-ai.com.

Blank Page

Table of Contents

List of Figures	x
List of Tables	xi
Introduction	1
1.1 Features	2
1.2 Specifications	2
1.2.1 Sensors and Flow Train	2
1.2.2 TCA330 Analyzer	3
1.3 Model Codes	5
Theory of Operation	7
2.1 Influences on the Measurement — pH Value	7
2.2 Influences on the Measurement — Flow	8
2.3 Influences on the Measurement — Temperature	9
Installation	11
3.1 Mounting	11
3.2 Wiring	12
3.2.1 Wiring - Power	13
3.2.2 Wiring, Sensor	13
3.2.3 Wiring, 4-20 mA Outputs	14
3.2.4 Wiring, Contact Relay Outputs	14
3.2.5 Wiring, Serial Output MODBUS RTU	14
3.3 Installing the Sensors	14
3.4 Plumbing	15
3.4.1 Sample Requirements	15
3.4.2 Connecting the Inlet and Drain fittings	15
3.4.3 Adjusting the Sample Flow Rate	16
3.5 Connecting the Optional Spray Cleaner	16
3.6 Connecting the Optional Chlorine Dosing Pump (DPC80)	17
Operation	19
4.1 Screen Map	19

4.2 KEYS	21
4.2.1 HOME/EXIT Key	21
4.2.2 BACK/HOLD Key	22
4.2.3 Selection Adjustment Keys	22
4.2.4 Alpha Numeric Entry	22
4.3 MENU STRUCTURE	23
4.3.1 HOLD (Output Hold)	23
4.3.2 CAL (Calibration Menu)	23
4.3.3 CONFIG (Configuration Menu)	24
4.3.4 INFO (Information Menu)	27
4.3.5 SIM (Simulation Menu)	28
4.3.6 Fault Screens	28
4.4 OUTPUT CONFIGURATION GUIDE	29
4.4.1 Configure 4-20 mA Output Range	29
4.4.2 Configure 4-20 mA Fault Condition and Cal	30
4.4.3 Configure Alarm Relays (Relays Optional)	30
4.4.4 Exit Menus and Return to Main Display	32
4.4.5 Sensor Start Up	32
4.5 USER SELECTABLE OPTIONS	32
4.5.1 Screen Lighting	32
4.5.2 Graphical Display	32
4.5.3 TAG Transmitter Name	33
4.5.4 Sensor Name	34
4.5.5 Password Protection	34
Calibration	35
5.1 Calibration Modes	35
5.1.1 AUTO Calibration Description	35
5.1.2 STANDardize Calibration Description	36
5.1.3 MANUAL Calibration description	36
5.2 pH Calibration Procedures	37
5.2.1 AUTO Cal Using pH 4.01, 7.00, 10.00 buffers	37
5.2.2 AUTO Cal Using Other pH Buffers	38
5.2.3 Standardize	39
5.3 Total Chlorine Calibration Procedures	40
5.3.1 AUTO CAL	40
5.3.2 Standardize	41

5.3.3 Manual Cal	42
MAINTENANCE.....	45
6.1 Total Chlorine Sensor	45
6.1.1 Removing or Replacing the Membrane	45
6.1.2 Polishing the Cathode	45
6.1.3 Refilling the Sensor	46
6.1.4 Storage	46
6.2 pH Sensor	46
6.2.1 Electrode Cartridge Installation	47
6.2.2 Electrode Cartridge Replacement	47
6.2.3 Electrode Cleaning	48
6.2.4 pH Electrode Cartridge Cleaning	48
6.3 Constant Head Flow Controller (CHFC)	49
TROUBLESHOOTING.....	51
7.1 Troubleshooting Guide	51
PARTS AND ACCESSORIES	55
8.1 TCA330 Replacement Parts	55
8.2 LXT-330 Front Panel Control Board Exploded	57
8.3 LXT-330 Front Panel Control Board Exploded, with Relays	57
8.4 LXT-330 Transmitter Case, Back with Cable Glands	58
8.5 LXT-330 Replacement Parts	59
Appendix.....	61
A. Auto Cal Buffer Tables	61
B. MODBUS RTU Register Listing	62
06 (0x06) Write Single Register	63
Registers	64
Fault Status	68
Warning Status	68
Sensor Type	69
C. AUTO SPRAY CLEANER	72
D. DC330 DE-CHLORINATION ANALYZER	73
E. DCA330 START UP PROCEDURES	74

List of Figures

Figure 2-1: TCA Output vs. pH.....	8
Figure 2.2 TCA330 Flow Dependence	8
Figure 3-1: TCA330 Reference Diagram.....	11
Figure 3-2: TCA330 Wire Transmitter, 24VDC or /110/22 VAC	12
Figure 3-3: Connections to Optional Spray Cleaner	17

List of Tables

Table 4-1:LCA330 Screen Map 19
Table 7-1: Troubleshooting Guide 51

This is a general purpose instrument designed for use in a non-hazardous area. It is the customer's responsibility to ensure safety especially when combustible gases are being analyzed since the potential of gas leaks always exist.

The customer should ensure that the principles of operating this equipment are well understood by the user. Misuse of this product in any manner, tampering with its components, or unauthorized substitution of any component may adversely affect the safety of this instrument.

Since the use of this instrument is beyond the control of Teledyne Analytical Instruments, referred as TAI, no responsibility by TAI, its affiliates, and agents for damage or injury from misuse or neglect of this equipment is implied or assumed.

Contents of this manual are believed to be correct at the time of printing and are subject to change without notice. Teledyne is not responsible for damage to the instrument, poor performance of the instrument or losses resulting from such, if the problems are caused by:

- Incorrect operation by the user.
- Use of the instrument in incorrect applications.
- Use of the instrument in an inappropriate environment or incorrect utility program (power supply).
- Repair or modification of the related instrument by anyone not authorized by Teledyne.
- There are no operator accessible parts. Service and maintenance to be done by authorized personnel only.
- If the equipment is used in a manner not specified by the manufacturer, the protection provided by the equipment may be impaired.

Introduction

The Teledyne Model TCA330 Total Chlorine Analyzer is designed to measure the concentration of Total Chlorine in drinking water, industrial cooling water, rinse water or other samples of fresh water that use chlorine in the range of 0-20 ppm as a disinfectant. Chlorine exists in water as a pH dependent mixture of hypochlorous acid and hypochlorite ion. Organic compounds containing chlorine may be added to the water or form in the water by reaction with the Free Chlorine. Chlorine may also react with ammonia in the water to form chloramines. Together these compounds are referred to as Bound or Combined Chlorine.

TCA330 measures Total Chlorine, which is the sum of bound chlorine and free chlorine in the sample.

The TCA330 is a complete system. The panel mounted system includes a Constant Head Flow Controller (CHFC), Total Chlorine sensor (TCS) and Flow Cell, pH sensor (SP3pH) and Flow Cell, and the LXT-330 Transmitter. Simply supply power to the LXT-330 Transmitter and connect the sample line in and the drain line out and the TCA330 is ready to use.

The CHFC maintains a constant sample flow to the pH and Chlorine flow cells. Pressure regulators and rotameters are not needed to maintain a constant flow rate, the CHFC provides trouble free sample conditioning between 10 and 80 gal/hr.

The Total Chlorine Sensor (TCS) is a three electrode amperometric sensor with a micro porous PTFE membrane, a gold cathode, a silver/silver halide anode and a 316 SS counter electrode. The counter electrode design provides a stable reference, virtually eliminating drift and the associated maintenance.

The LXT-330 Transmitter applies a fixed voltage on the anode and cathode and measures the current flow.

Chlorine compounds diffuse through the PTFE membrane and react with a potassium iodide fill solution. The iodide is oxidized to iodine by the various chlorine compounds. The iodine is then reduced (gains electrons) by the gold cathode back to iodide ion. Silver on the anode is oxidized (donates electrons) to silver iodide completing the current loop.

With stable temperature, pH and sample flow, the current flow is proportional to the total chlorine concentration.

Many competitive total chlorine analyzers require service on a monthly or bimonthly basis. The TCS is an amperometric sensor that requires refilling every 3-6 months. The chloride concentration of the electrolyte increases over time as the measured chlorine is reduced to chloride by the potassium iodide degrading the electrolyte. The replaceable PTFE membrane is designed for long term stability and typically lasts over a year. Replacing the PTFE membrane and recharging the electrolyte is easily accomplished without the use of tools.

The Model LXT-330 transmitter can be 24 VDC powered or 100-240 VAC line powered. The standard configuration has a 4-20 mA output and a RS485 serial communication port with MODBUS®RTU output. Alarm relays are standard on either line powered transmitter.

1.1 Features

- Panel mounted system with easy installation
- Plumb and Play design, ready to use
- Automatic pH Compensation. No expensive reagents to mix or spill with convenient sample port
- Automatic flow control, eliminates pressure regulators and rotameters
- LXT-330 Transmitter capability, dual measurements, 24 VDC or 110/220 VAC power, graphical plots
- Compliant with EPA Method 334.0

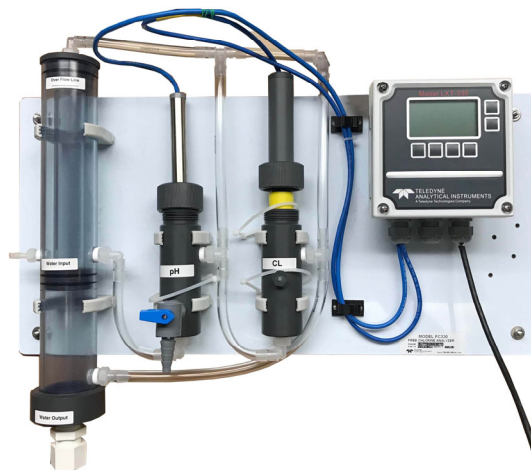

1.2 Specifications

1.2.1 Sensors and Flow Train

Chlorine Sensor:

Digital Protocol, Potentiostatic, Gold Cathode/Silver-Silver Halide Anode, SS316L Counter electrode

pH Sensor:

Digital SP3 protocol, 316L stainless steel body with replaceable electrode cartridge

Measurement Range:

Chlorine: 0.05 to 20 ppm (High Range)

0.005 to 2.00 ppm (Low Range)

pH: 4 to 14 pH

Operating Temperature:

0° C to 50° C (32° F to 122° F)

Min/Max Flow:

38 L/hr. to 300 L/hr. (10 gal/hr. to 80 gal/hr.)

Wetted Materials:

PVC, PP, PVDF, PTFE, Glass, 316 SS

Process Connections:

Input ¼" FNPT with barb fitting, Drain ¾" FNPT

Response Time:

T90 in 2 minutes

Electrolyte Life:

3 to 6 months

**1.2.2 TCA330 Analyzer****Measurements:**

Chlorine: 0.00 ppb to 22.00 ppm

pH: 0.00 to 14.00 pH

pH Compensation of Total Chlorine:

pH 4 - 12

Display:

128 x 64 pixels (2.75" x 1.5") LCD, Black on Grey background, Blue on White background with LED backlight on

Outputs:

(1) 4-20 mA for Total Chlorine set to Sensors Range

(1) 4-20 mA for pH (Optional) set 0-14 pH

Modbus RTU (standard)

Alarm Relay Ratings:

Three (3) SPDT, 1 form C, 250 VAC, 10 Amp resistive maximum, relays. User configurable as Hi/Lo alarms with expiration timer, Periodic Timers or Fault Alarms

Input Power

Code -1 24 VDC (18-36 VDC @ 250 mW minimum)

Code -2 100-240 VAC, 50/60 Hz, 4W, protected with 250V, 1A, Slow Blow fuse

Enclosure:

Beige Polycarbonate, IP65, weatherproof, ½ DIN,(L x W x D) 5.7” X 5.7” X 3.5” (14.4cm X 14.4cm X 9.0cm)

Environmental Conditions:

Outdoor use (IP65)

Ambient Temperature -20°C - 70°C (24 VDC)

-20°C - 60°C (100-240 VAC)

Storage Temperature -30°C - 85°C

Relative Humidity 0 – 80%, up to 31°C

Decreasing linearly to 50% RH at 40°C

Altitude Up to 2000 m (6500 ft)

Mains Supply Voltage Fluctuations up to ±10% of the nominal voltage

Transient over voltages: CAT II

Pollution Degree: 2

1.3 Model Codes

Model TCA330 -						
Sensor type and Range	0		0.05 to 20 ppm Total Chlorine (Standard)			
	1		0.005 to 2.00 ppm Total Chlorine			
	2		0.05 to 20 ppm Total Chlorine (Seawater)			
	3		0.005 to 2.00 ppm Total Chlorine (Seawater)			
	pH Comp	1		pH Sensor Stainless Steel (Standard)		
		2		pH Sensor Titanium (Seawater)		
	Power	-1		24 VDC Powered Transmitter		
		-2		100-240 VAC powered Transmitter (Standard)		
		Outputs and Relays	2		(x2) 4-20mA Outputs & (3) Relays (Modbus)	
			3		(x2) 4-20mA Outputs & (3) Relays (HART)	
Spray cleaner	0		No Spray Cleaner/ Std. CHFC			
	1		Spray Cleaner on Cl2/ Std. CHFC			
	2		No Spray Cleaner/ High Flow CHFC			
3		Spray Cleaner on Cl2/ Hi Flow CHFC				
		Enclosure		0 Standard Panel Mount (No Enclosure)		
				1 Fiberglass Enclosure, Clear Door		
				2 Fiberglass Enclosure, Opaque Door		
TCA330 -	0	1	-2	2	0	0

Example above shows part# TCA330-01-2200, a two channel TCA330 transmitter, 0.05 to 20 ppm Total Chlorine range and SP3 pH sensor, 110/220 VAC powered with one 4-20 mA output with MODBUS RTU, 3 Relays (one used for Spray Cleaning option) and spray cleaner, Panel Mounted

Blank Page

Theory of Operation

This section provides a basic overview of the Teledyne TCA330 Total Chlorine Analyzer. It covers physical and chemical influences on the measurement and the menu structure of the analyzer.

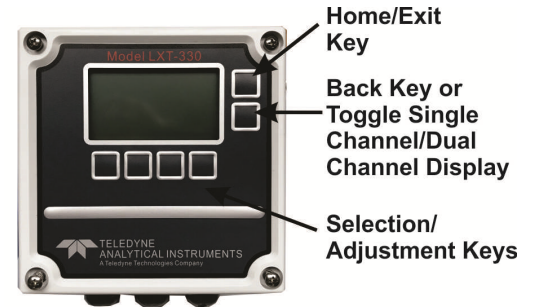

2.1 Influences on the Measurement — pH Value

The TCA analyzer measures Total Chlorine and the total chlorine concentration does not change with changes in the pH, there is always the same amount of Total Chlorine. The output of the sensor is however pH dependent, see figure 2.1, the output of the sensor decreases 5%/pH as the pH increases.

The LXT-330 transmitter uses the pH signal from the SP3 pH sensor to compensate for the decreasing output. The measured value and the pH value are combined and the corrected Total Chlorine concentration is displayed.

The highest accuracy is attained when calibrations are performed at neutral pH values and higher chlorine concentrations.

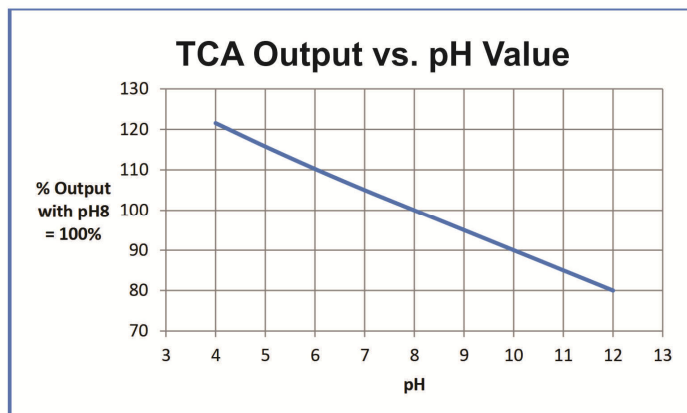

Figure 2-1: TCA Output vs. pH

2.2 Influences on the Measurement — Flow

The TCA330 Analyzer consumes chlorine to produce the signal. The area near the sensing tip will become depleted of chlorine without adequate flow to replenish the sample. The sensor requires a minimum velocity of 0.5 ft./sec past the membrane. Below this value the sensor will indicate a lower concentration than the actual value. Higher flow rates have little to no effect on the measurement. See Figure 2-2.

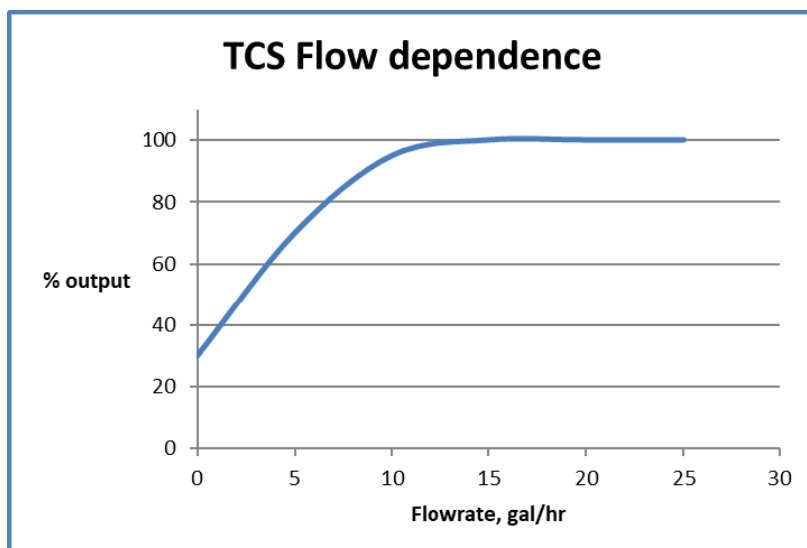

Figure 2.2 TCA330 Flow Dependence

2.3 Influences on the Measurement — Temperature

The Total Chlorine Sensor (TCS) digitally outputs a temperature corrected value to the transmitter. The temperature sensor is located in the TCS sensor and it has a response time of several minutes. Rapid changes of temperature will introduce an error until the sensor has equilibrated to the new temperature. Calibration should be done close to the process temperature for the highest accuracy.

Blank Page

Installation

Mount the TCA330 in a location where there is easy access to the analyzer and sensors. Install the system in an area where vibrations, electromagnetic and radio frequency interference are minimized or absent.

Do not mount in direct sunlight or areas of extreme heat. The TCA330 is suitable for outdoor use if mounted with a protective cover or sunshield.

3.1 Mounting

The TCA330 panel is drilled with 4 x 0.265" holes, one at each corner, and is designed to use 1/4" -20 hardware or 6mm metric hardware.

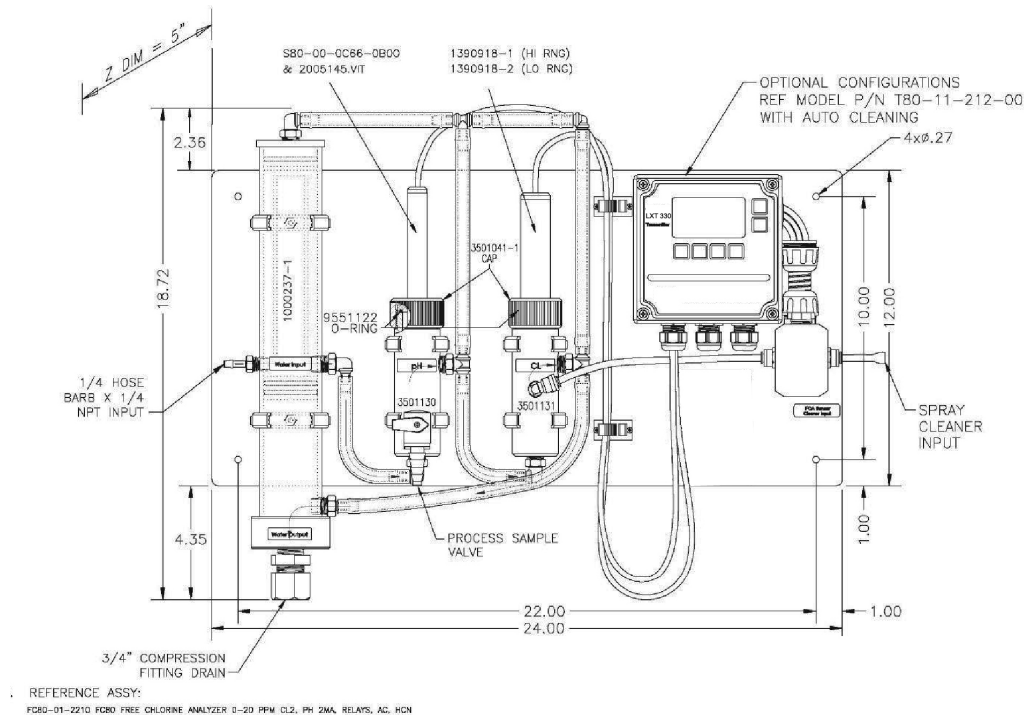

Figure 3-1: TCA330 Reference Diagram

3.2 Wiring

Electrical wiring should only be conducted by qualified personnel. See the TCA330 wiring diagram in Figure 3-2 which includes wiring for MODBUS, optional relays and the optional digital preamp.

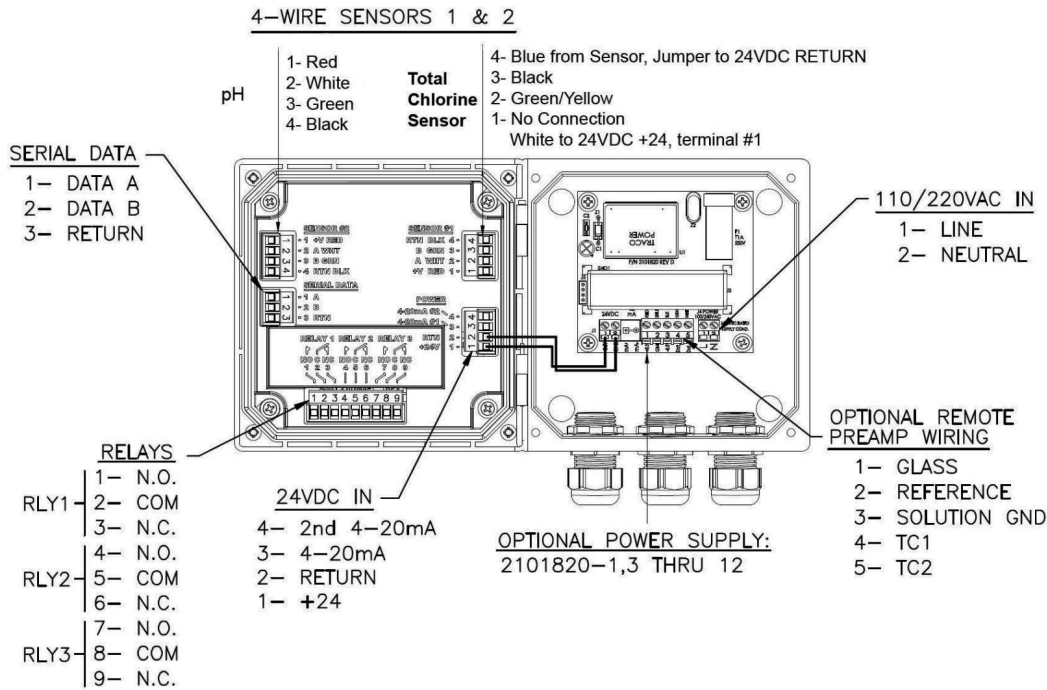

Figure 3-2: TCA330 Wire Transmitter, 24VDC or /110/22 VAC

	Warning: RISK OF ELECTRICAL SHOCK
	Disconnect Power before opening instrument.
	WARNING: Electrical installation must be in accordance with the National Electrical Code (ANSI/NFPA-70), Canadian Electrical Code and/or any other applicable national or local codes.

3.2.1 Wiring - Power

Teledyne recommends using a thermoplastic, outdoor sunlight resistant jacketed cable, wet location rated and 1/2" flexible conduit. The power should be hard wired with a switch or breaker to disconnect the analyzer from the main power supply. Install the switch or breaker near the analyzer and label it as the Power Switch for the analyzer.

24VDC(4 wire configuration)

Attach the 24VDC power cable to terminals #1 and #2 as shown in Figure 3-2 and on the diagram inside of the LXT-330 cover. Attach the 4-20 mA 1 cable to terminals #3 (out) and #2 (return)single channel unit and attach the 4-20 mA 2 cable to terminals #4 (out) and #2 (return) for a two channel instrument.

Feed the cables through the gland fitting on the right hand side of the LXT-330 Transmitter. Tighten the cable gland to provide a good seal to the cable. The instrument can be powered up at this point with no harm to the analyzer but it is best to wait until the sensor is installed.

110/220 VAC(4 wire configuration)

Attach power cable as shown in Figure 3-2 or as on the diagram inside of the transmitter cover. Feed the cable through the gland fitting on the right hand side of the LXT-330. Tighten the cable gland to provide a good seal to the cable. The instrument can be powered up at this point with no harm to the analyzer but it is best to wait until the sensor is installed.

3.2.2 Wiring, Sensor

The Total Chlorine Sensor and the SP3 pH Sensor were connected to the TCA330 analyzer at the factory, no additional connections are necessary. Color coded connections for these sensors are shown in the wiring diagrams in the Appendix or on the inside cover of the LXT-330 transmitter.

When replacing a sensor, attach the sensor wires as described on the diagram inside the LXT-330 cover. Feed the sensor cable through the gland fitting on the left hand side of the LXT-330. Do not use the same gland fitting for the AC power or Alarm/Relays. The green terminal strip connectors are detachable from the circuit boards. Remove the connector by pulling straight back from the circuit board.

3.2.3 Wiring, 4-20 mA Outputs

24 VDC or 110/220 VAC powered instruments:

For instruments powered with 24VDC or with the internal 110/220 VAC power supply, Model LXT-330-XX-1X-XX (24VDC) and LXT-330-XX-2X-XX (110/220 VAC), connect the 4-20 mA cable(s) to terminals #3 (out) for channel 1 and #2 (return) and to terminals #4 (out) for channel 2 and #2 (return).

3.2.4 Wiring, Contact Relay Outputs

The standard configuration has three form C, 250 VAC, 10 Amp resistive max. relays that can be wired either **normally open (NO)** or **normally closed (NC)**. The default configuration is set to use the relays as normally open. If the optional spray cleaner was ordered then one of the relays is used to control the cleaning cycle.

3.2.5 Wiring, Serial Output MODBUS RTU

Attach the sensor wires as shown in Figure 3-2 or as described on the diagram inside the LXT-330 cover. Feed the sensor cable through the gland fitting on the left hand side of the LXT-330. Do not use the same gland fitting for the AC power or Alarm/Relays. See MODBUS command register in the Appendix.

3.3 Installing the Sensors

The TCA330 is supplied with the sensor cables pre-wired to the analyzer. The TCA330 instrument and sensors were calibrated at the factory and should be ready for use when assembled. However, changes may have occurred during shipping and storage requiring recalibration. (See Calibration section below)

The pH sensor mounts in the Flow Cell using an o-ring sealed flange/union mount with threaded locking cap.

First remove the protective cap from the sensing end of the sensor and save it for future use, the cap contains a potassium chloride solution use care when removing the cap from the sensor. Insert the sensor into the flow cell. There is an o-ring seal inside the flange that seals against the face of the flow cell. Slide the sensor into the flow cell and then hand tighten the knurled compression cap to fix its position.

The Chlorine sensor is held in the flow cell with a union nut. Slide the sensor into the flow cell and hand tighten the compression cap **after filling the sensor with electrolyte.**

1. **Lift the silicone band to expose the vent hole** and unscrew the measuring cap from the sensor.
2. Fill the cap to the bottom of the threads with the gelled electrolyte and tap it gently to dislodge any trapped bubbles inside the cap.
3. Screw the sensor into the measurement cap at a 45° angle ensuring all air inside the chamber is purged through the vent hole on the side of the cap.
4. When the o-ring begins to seal continue slowly tightening until it hits the stop.
5. Replace the silicone band back over the vent hole and rinse the purged electrolyte from the sensor body with water.

The sensor is ready to use, re-polarize the sensor for 60 minutes before calibration.

Refill the sensor with electrolyte (P/N K00344) every 3-6 months, depending on the chlorine level measured.

The measured chlorine is reduced to chloride inside the cell and must be periodically removed. Samples with around 5 ppm total chlorine require the sensor to be refilled every 3-4 months.

3.4 Plumbing

3.4.1 Sample Requirements

The constant head flow controller can adapt to changing sample flows between 10 and 80 gal/hr.(40-300 L/hr.)

Minimum flow: 10 gal/hr. (38 L/hr.)

Sample Pressure: 1 to 30 psig (0.1 - 2 bar)

Temperature: 32° to 122°F (0° to 50°C)

3.4.2 Connecting the Inlet and Drain fittings

The TCA330 is intended for wall mounting only.

Sample Inlet:

A 1/4" barbed fitting is provided for the sample inlet. If desired, a 1/4" compression fitting can be used. The sample inlet is 1/4" FNPT. Attach the feed water line to the Constant Head Flow Controller with an adjustable shut off valve.

Sample Drain:

The sample drains through the 3/4" FNPT hole at the bottom of the CHFC. Attach a 3/4" fitting to a length of soft tubing and allow the waste to drain to open atmosphere. Do not restrict the drain line.

The sample can be introduced after the sensors have been calibrated and installed in the flow cells.

3.4.3 Adjusting the Sample Flow Rate

Adjust the flow so the sample water fills the tube and slightly overflows into the center tube to drain. This provides a constant flow to the chlorine and pH sensors controlled by the height of the water column. The sample flow rate must always be high enough to overflow the center tube or variations in the flow rate will occur causing decreased output from the Total Chlorine Sensor.

Once the sample has been introduced, purge the air in the lines by squeezing and releasing the tubing connecting the flow cells. First the tubing from the CHFC to the first flow cell and the tubing between the flow cells. The water draining back to the CHFC typically flows fast enough to arc to the center drain hole. A dribbling flow indicates an obstruction or air bubble trapped in the flow train.

3.5 Connecting the Optional Spray Cleaner

Warning: *The Relay controlling the solenoid will trigger upon Power Up which starts a cleaning cycle. The Sensors should be installed with the Sample flowing before powering the analyzer.*



1. Remove the 1/4" polypropylene tube from the John Guest fitting on the right side of the solenoid cleaner enclosure.
2. Provide 20-40 psi water or air to the 1/4" John Guest fitting.

3. Manually actuate the relay for test purpose in SIM > RELAYS > RLY 1 > ON/OFF

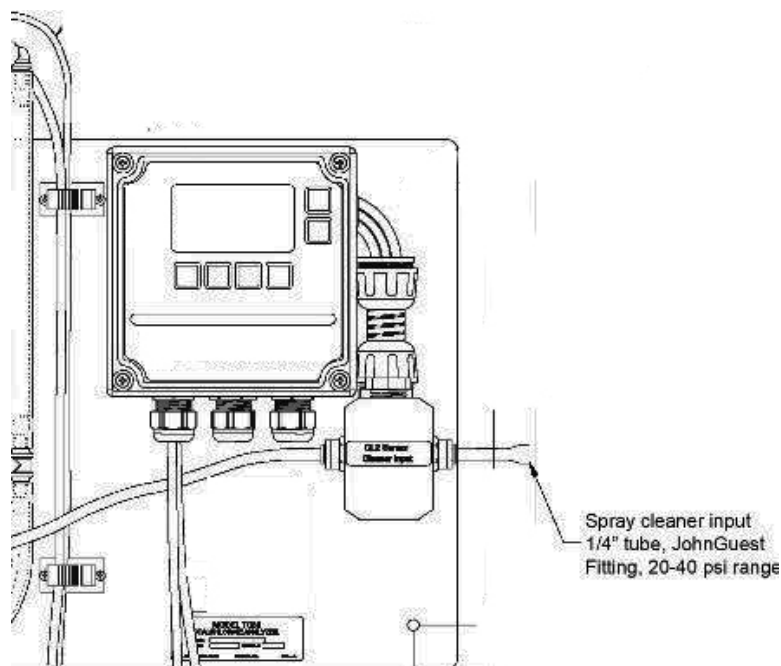

Figure 3-3: Connections to Optional Spray Cleaner

3.6 Connecting the Optional Chlorine Dosing Pump (DPC80)

Remove the lid from the DPC80. Connect a power cord, 110 VAC, to the Line and Neutral terminals inside the DPC 80 chlorine metering pump. Replace the lid. Mount the pump/controller near the TCA330 panel. The DCA330 is supplied with 10 ft. of tubing for the peristaltic pump. Lift the Tan portion of the pump from the middle to expose the rollers. Place the tubing into the pump and close the tan cover.



Blank Page

Operation

4.1 Screen Map

Table 4-1 highlights the various operational keys and function. The sections that follow describe the key and function in detail.

Table 4-1: TCA330 Screen Map

CAL (Calibration)	Auto	Cal 1 (Offset) using Calibration Solution				
		Cal 2 (Slope) using Calibration Solution				
	Standardize	Enter Grab Sample Determined Value				
	Manual	Enter Offset, the PV value and associated mV				
		Enter Slope, mV/pH, mV/decade, mV/ppm...				
Temp	Enter measured Temperature					
CONFIG (Configuration)	XMTR	LCD	Set Up	Temp. Format	°C or °F	
				Contrast	Adj. 0-100%	
				Back Light	Enter ON time	
				Range Lock	Choose: Auto, ppb, ppm, ppT	
			Graph	Line	Screen Duration	
				Gauge		
				Bar		
			Label	TAG ID	Enter Name	
				TAG	ON/OFF	
				POP UP	ON/OFF	
				SENSOR	Enter Name	
			Output	4-20 mA (1 or 2)	Range (PV or Temp.)	4 mA =
					20 mA =	
		Cal (more)			Trim 4.00 mA	
					Trim 20.00 mA	
		FAULT		Fault (more)	3.5 mA	
					22 mA	
					NONE	
		RELAY		Relay 1	Alarm	Set Point
					Timed	Period, Duration
					Fault	
			Relay 2	Alarm	Set Point	
				Timed	Period, Duration	
				Fault		
		Relay 3	Alarm	Set Point		
			Timed	Period, Duration		
			Fault			
HOLD	Time out: None, 15 min, 30 min...					
Serial	Address					
	Baud rate					
	Format					

	Password	Menu	Off/On " _ _ _ _ _ "	
		CAL	Off/On " _ _ _ _ _ "	
		CNFG	Off/On " _ _ _ _ _ "	
		SIM	Off/On " _ _ _ _ _ "	
	Sensor	Sensor 1 or 2	Type	Choose Type: pH, Cond, ORP
			T COMP	Enter % Comp
		ISO PT	Enter mV value	
		Qty of Sensors	Choose 1 sensor or 2 sensors	
	COMP	Dissociation, Interference, Percentage, OFF		
	Load Default	Sensor/Transmitter	Yes/No	
DAMP	Enter Signal Dampening (# of readings to average, 0-100)			
INFO (Information)	XMTR	Configuration, Serial #, Name, Outputs		
	Sensor	Calibration logs, Serial #, Name		
SIM (Simulate)	System	Sensor 1 or 2	Fixed value	
			Ramp	
	Relays	#1 ON/OFF		
		#2 ON/OFF		
		#3 ON/OFF		
4-20 mA	4-20 mACh 1	Enter Value		
	4-20 mACh 2	Enter Value		

4.2 KEYS

The functions associated with each key are displayed on the screen, above the Selection Adjustment Keys and to the left of the HOME and BACK keys. **Press any Selection Adjustment key twice within one second to enter the HOME Menu Screen.**

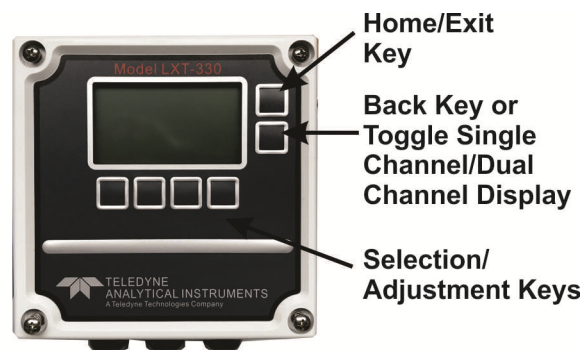

4.2.1 HOME/EXIT Key

The **HOME** key performs two functions, it selects which Home Screen is displayed and it returns from the active screen to the HOME Menu Screen from anywhere inside the menu structure.

Three Display screens are available: (Press BACK Key until a single channel is displayed then the HOME Key)

- DATA SCREEN:** Displays the measurement type, numerical value, engineering units, % output of the 4-20 mA channel and temperature.
- nA SCREEN:** Displays the measurement type, the sensor's raw nano-amp value, % output of the 4-20 mA channel and temperature.
- GRAPH SCREEN:** Displays a graphical representation of the 4-20 mA channel % Output, the measurement type, the engineering units, and temperature. Only one of the three graphical display styles is available through the HOME key, either the Bar, Gauge or Line display. Choose which style will be displayed in the Graph Menu. (pathway to Graph Menu: CONFIG → XMTR → LCD → Graph menu)

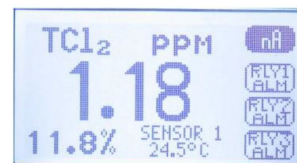

Total Chlorine ppm



Total Chlorine nA

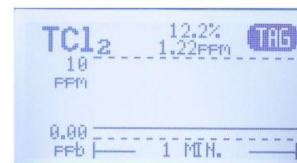

Total Chlorine Graph

Each of the above screens also displays the

condition of the optional Alarm Relays, black if energized and white if de-energized.

The HOME key changes to the **EXIT** key in the HOME Menu Screen, pressing EXIT prompts the user to “Save Changes” YES/NO when exiting the HOME Menu. YES applies any changes made in the menus, NO exits the HOME Menu without applying any changes made in the menus.

4.2.2 BACK/HOLD Key

The **BACK** key changes the screen to the previously displayed screen when inside a menu, it moves BACK one screen. On a dual channel transmitter it toggles between the PV1, PV2 and Dual Channel Screens. The **HOLD** key toggles the output HOLD function ON/OFF in the MENU HOME screen.

4.2.3 Selection Adjustment Keys

The (4) Selection/Adjustment keys allow navigation and numerical adjustments to be made in the MENUS. **To enter the HOME Menu screen press any of the Selection/Adjustment keys twice within one second.** The various Menu choices and adjustment tools are displayed above the buttons once inside the MENU.

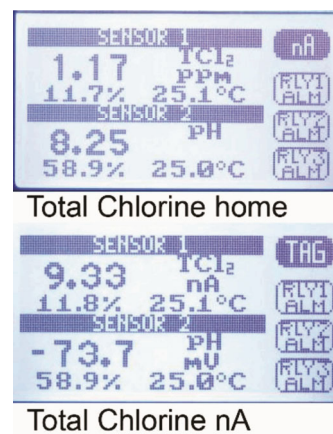

4.2.4 Alpha Numeric Entry

The **LABEL** and **PASSWORD**(Caps and Numbers only) Menus allow alphanumeric entry. Entry is accomplished by scrolling through the alphanumeric list with the ▲ (forward) and ▼ (backwards) arrows to the character of choice and then moving to the NEXT digit. Pressing and holding the ▲ or ▼ keys will initiate two speed auto scrolling. The character set is sequentially listed below. The first character in the set is an empty space.

! ” # \$ % & ‘ () * + , - . / 0 1 2 3 4 5 6 7 8 9 : ; < = > ? @ A B C D E F
 G H I J K L M N O P Q R S T U V W X Y Z [¥] ^ _ ‘ a b c d e f g h i j
 k l m n o p q r s t u v w x y z { | } → ←

4.3 MENU STRUCTURE

Double tap any Selection/Adjustment key to enter the HOME Menu Screen. Five menu choices will appear, **CAL**, **CONFIG**, **INFO**, **SIM** and **HOLD**. Each of the Menus is detailed below.

4.3.1 HOLD (Output Hold)

Pressing the **HOLD** Key activates the HOLD function, HOLD is ON, displayed.

- Freezes the 4-20 mA output at the last value prior to activation
- Freezes optional Alarm Relays in the current state
- While in the HOLD mode the % Output display toggles between the last value and HOLD

Pressing HOLD again turns the hold function off, Hold is OFF, displayed. The HOLD function remains ON until it is turned OFF. (See Time Out in CONFIG>XMTR>OUTPUT>HOLD).



4.3.2 CAL (Calibration Menu)

Four options are available, **AUTO**, **STAND**, **MANUAL** and **TEMP**. On dual channel instruments choose Sensor 1 or Sensor 2 when prompted.

The first screen asks, “**Is this a New Sensor, YES / NO**”. If YES the calibration history from the previous sensor is cleared from memory and a new register is started, if NO then the calibration is written to the memory stack, (3) sets of data are stored.



- **AUTO** is a two point calibration. The calibration proceeds in two steps, Auto Cal 1 is an offset calibration and Auto Cal 2 is a slope calibration. Auto Cal provides automatic solution recognition of the calibration

solutions used for each measurement in accordance with the following list:

1. pH Calibration Buffers(US Standard), pH 4.01, pH 7.00 and pH 10.00 (see Appendix A).
2. Total Chlorine: Zero ppm (Sodium sulfite, Na₂SO₃ in water), chlorinated water, DPD tested.
 - Any two solutions can be used for AUTO calibration however if solutions other than those listed above are used for calibration then the calibration values must be entered manually.
 - **STAND** is standardization, a single point calibration. Standardizations are typically used to adjust the process reading to agree with a laboratory determined “grab sample” reading.
 - **MANUAL** is a data entry screen. Manual calibration allows the user to enter a concentration with the corresponding mV value and a slope for an electrode. Laboratory generated calibration data for an electrode can be input to a remote analyzer where calibration is difficult or impractical.
 - **TEMP** allows the displayed temperature to be trimmed to agree with actual process temperature.



4.3.3 CONFIG (Configuration Menu)

Four options are available in the Configure Menu, **XMTR**, **SENSOR**, **LOAD DEFAULT** and **Dampen**.

1. **XMTR** enters the Transmitter Configuration menu.
 - **LCD** access the Display Configuration Menu
 - **SETUP** adjust screen lighting characteristics
 - ❖ **Temp.** Choose °C or °F
 - ❖ **CONT** adjust Contrast



- ❖ **BACK LIGHT** adjust Backlight Timeout, from always ON to OFF after 10 minutes
- **GRAPH** provides the choice of which Graph style is displayed on the Home screen.
 - ❖ **LINE**, Moving value, vertical scale set to 0-100% of the 4-20 mA output and user defined time scale
 - ❖ **GAUGE**, Current reading 0-100% of 4-20 mA range
 - ❖ **BAR**, Current reading 0-100% of 4-20 mA range
- **LABELS**
 - ❖ **TAG**, Enter up to 2 lines x 16 characters, example, Name, tag #... Displayed in INFO screen
 - ❖ **TAGON**, Turn TAG ON/OFF, adds TAG to Main Display Sequence, DATA → mV → GRAF → TAG → DATA
 - ❖ **POP UP**, Turns ON/OFF, the double tap HOME Screen pop up memo
 - ❖ **SENSOR**, Enter up to 2 lines x 16 characters
- **OUTPUT** access the Output Configuration Menu
 - **4-20 mA** configure 4-20 mA output (PV or Temp or More)
 - ❖ **PV RANGE** Enter 4 mA value and 20 mA value
 - ❖ **MORE**
 - **CAL** Trim 4.00 mA output and 20.00 mA output
 - **FAULT** Choose fault condition 3.5 mA, 22 mA, None

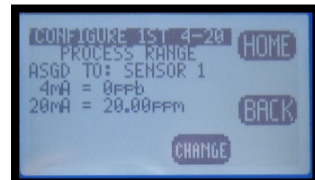
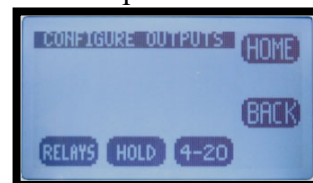

- **RELAY**

- ❖ **RLY 1,2,3** Choose relay type:

- **Alarm**, enter the Set point ON, Set Point OFF, Expiration time, Delay ON and Delay OFF times and the State, energize: changes state from de-energized to energized on alarm.
 - **Timed**, Enter Period, Duration times and Hold On/Off
 - **Fault**, No input required, relay condition changes from energize to de-energize.
 - **Disable**, Inactivates relay and removes the relay button from the HOME Screen display.



- **HOLD**, Freezes outputs at current value and locks relays in their current state.

- ❖ **Hold Timeout**, Removes HOLD after a certain period of time, default setting: No Timeout, selections include 15 minutes, ½ hour, 1 hour

- **SERIAL MODBUS** configure serial output,

- **ADDRESS**, enter address: 001 to 247
 - **BAUD**, Choose baud rate, default 9600
 - **FORMAT**, set serial data format, default value: 8N1, 8 bit, no parity bit, 1 stop bit

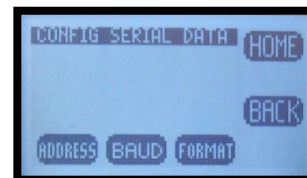

- **PASSWD** Enter 4 character password to protect access to MENU Level, CAL Menu, CONFIG Menu and SIM Menu (simulate). Each level can be turned ON or OFF and can have a unique password.

- **MENU** ON/OFF __ Locks Main Menu
 - **CAL** ON/OFF __ Locks CAL and CONFIG
 - **CONFIG** ON/OFF __ Locks CONFIG
 - **SIM** ON/OFF __ Locks SIM and CONFIG



2. SENSOR enters the sensor configuration menu.

○ Choose **SENSOR 1 or 2**

- **TYPE**, Allows LXT-330 transmitter to configure the SP3 sensor. For use only when switching the measurement electrode type in an SP3 sensor, i.e. for a pH electrode to a pION electrode. Select Sensor Type: pH, ORP, DO₂, NH₃, NH₄⁺, Br⁻, Ca⁺⁺, Cl⁻, Conductivity, Resistivity, Cu⁺⁺, CN⁻, F⁻, NO₃⁻, K⁺, Ag⁺, Na⁺, S⁻
- **T COMP**, Enter % temperature compensation per degree: pH, 0.33%, Total Chlorine 0%.

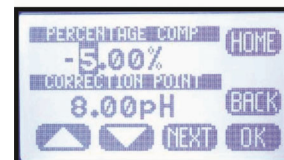
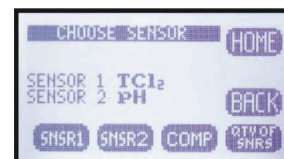

- **COMP** Dual Channel Only, Sets compensation type, (effect of ch2 on ch1): **Dissociation** (pKa), NH₄⁺, Total Chlorine, HF, S⁻², **Interference**, X ppm Sensor 2 = 1 ppm Sensor 1, **Percentage**% change per pH.
- **Qty of SENSORS**, Choose 1 or 2.

3. LOAD DEFAULT resets all Menus to factory default configuration.

4. DAMPEN sets the number of measurements averaged for the displayed PV.

4.3.4 INFO (Information Menu)

The Information Menu provides three choices:

1. **Transmitter Screen**: details the Name, Power type, Serial #, Firmware version and the output configuration(s).
2. **Sensor Screen**: details the Name, Part #, Serial # and three sets of Calibration data.
3. **COMP**: displays the pKa, the sensor affected and the dissociation Factor

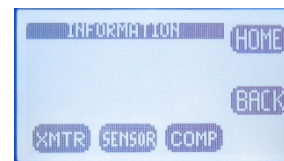

4.3.5 SIM (Simulation Menu)

The Simulation menu allows the Input or Output signals to be simulated.

1. **SYSTEM** allows the Input to be simulated. Two choices are available, FIXED is a fixed value, RAMP varies the signal across the 4-20 mA range, from the lowest value to the highest value and back, activating and deactivating relays if present. The RAMP has two adjustments the Ramp period, 30 seconds to 2 minutes and Duration; 1 cycle, 5, 10, 20, 30 minutes.
2. **RELAYS** allows individual relays, #1, #2, and #3 to be activated and deactivated
3. **4-20 mA** allows the output to be simulated from 4.00 mA to 20.00 mA.



4.3.6 Fault Screens

Fault	Definition	Recommendation
Memory Error	AN ERROR WAS FOUND WITH THE MEMORY OF THE MICROCONTROLLER	RETURN TO FACTORY FOR SERVICE
Input Voltage OOT	POWER IS OUT OF TOLERANCE	CHECK WIRING TO THE TRANSMITTER
+12V OOT	ONBOARD 12V IS OUT OF TOLERANCE	RETURN TO FACTORY FOR SERVICE
+3.3V OOT	ONBOARD 3.3V IS OUT OF TOLERANCE	RETURN TO FACTORY FOR SERVICE
Loss of Comm	COMMUNICATION WITH THE SENSOR WAS LOST	CHECK WIRING TO THE SENSOR
No Sensor	NO SENSOR WAS FOUND AT START-UP	CHECK WIRING TO THE SENSOR
Cal Failed	SENSOR CALIBRATION FAILED	1) CLEAN SENSING TIP 2) VERIFY SOLUTIONS 3) DO NOT LEAVE UNATTENDED 4) RE-CALIBRATE
Relay 1 Expired	RELAY 1 TIME ON EXPIRED	1) CHECK SENSOR OP 2) CHECK AUX EQUIP A) PUMPS B) TANKS
Relay 2 Expired	RELAY 2 TIME ON EXPIRED	1) CHECK SENSOR OP 2) CHECK AUX EQUIP A) PUMPS B) TANKS
Relay 3 Expired	RELAY 3 TIME ON EXPIRED	1) CHECK SENSOR OP 2) CHECK AUX EQUIP A) PUMPS B) TANKS

4.4 OUTPUT CONFIGURATION GUIDE

1. Install and wire the LXT-330 Transmitter as described in Sections 3.1 and 3.2 above.
2. Connect the sensor to the transmitter as described in Section 3.2.2 above.
3. Supply power to the Model LXT-330 transmitter.
4. Verify the proper measurement type is displayed, pH and TC₁. The sensor automatically uploads the measured parameter, the calibration data and the range of measurement to the transmitter. The default configuration of the 4-20 mA output is the range of the sensor, 0-14 pH for pH sensors and 0.00 -20.00 ppm for Total Chlorine. To change the 4-20 mA range, follow the instructions in Section 4.4.1 below.

4.4.1 Configure 4-20 mA Output Range

- Double press any key except the HOME key to enter the HOME Menu. Follow the path below to set the 4-20 mA range.
- HOME Menu → Press CONFIG → XMTR → OUTPUT → 4-20 (1)(2) → PV or TEMP
- Press CHANGE to enter New Values.
- Choose 4 mA value, press OK
- Enter value using ▲ or ▼ and NEXT to move to the next digit, press OK→Back
- Choose 20 mA value, press OK,
- Enter value using ▲ or ▼ and NEXT to move to the next digit, press OK→Back
- Press BACK to return to the CONFIGURE 4-20 mA screen or HOME to return to the HOME Menu screen.

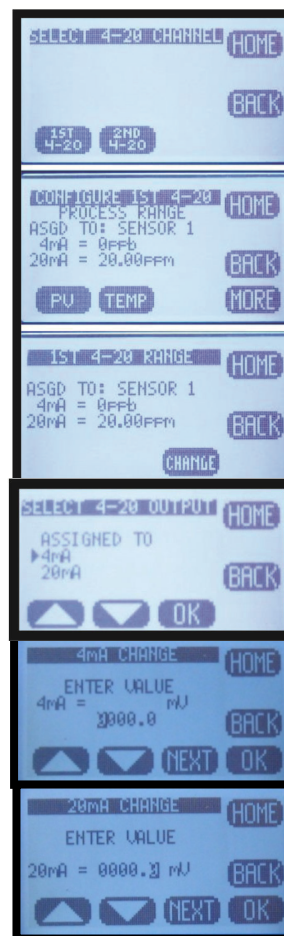

4.4.2 Configure 4-20 mA Fault Condition and Cal

- In the CONFIGURE 4-20 mA screen, Press **MORE** → **FAULT** or
- Choose **Low Fault 3.5 mA** or **Hi Fault 22 mA** or **NONE**, (default setting **NONE**), Press OK
- Press **BACK** → **CAL**, connect DVM to 4-20 mA line, Press 4.00 mA then adjust value to the DVM reading, Press 20.00 mA and adjust value to the DVM reading. The 4-20 mA output is calibrated.

4.4.3 Configure Alarm Relays (Relays Optional)

1. HOME Menu → Press **CONFIG** → **XMTR** → **OUTPUT** → **RELAYS** → **RLY1**
2. Choose the **ALARM**, **TIMER**, **FAULT** or **DISABLE** mode for Relay 1
3. **ALARM** Displays:
 - a. **SET POINT ON**: The Process Variable Value that activates the relay.
 - b. **EXPIRATION**: Enter a time that should not be exceeded before the PV should have changed enough to activate the OFF set point. At the Expiration time the relay is deactivated and a Fault condition is initiated. Fault: Relay 1 Time expired: Cause: Loss of reagent, failed sensor
 - c. **Delay ON**: The amount of time the PV must remain above/below the set point before the relay activates.
 - d. **SET POINT OFF**: The Value of the process variable that deactivates the relay.
 - i. **SET POINT OFF**> Set Point → Low Set Point
 - ii. **SET POINT OFF**< Set Point → Hi Set Point
 - e. **Delay OFF**: The amount of time the PV must remain above/below the hysteresis point before the relay deactivates.
 - f. **STATE**: **Energize** (relay is energized on activation)/**De-energize** (relay is de-energized on activation)

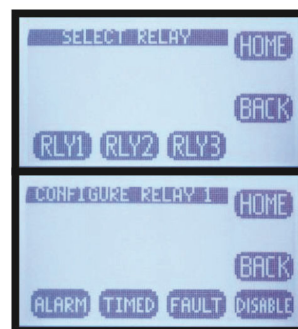

4. **TIMER** activates the relay periodically for a specific duration, user configured period and duration
5. **FAULT** sets the relay condition to a de-energize state and NC relay closes in response to a Fault condition.
6. **DISABLE** turns off the relay and removes it's icon from the HOME screen

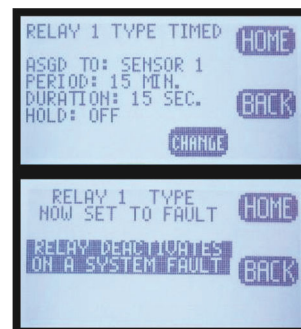

Setting up an Alarm Relay

1. Choose **ALARM**
2. Press **CHANGE** to enter new values
3. Choose ON Set Point, Press OK
4. Enter value using ▲ or ▼ and NEXT to move to the next digit, press OK, press BACK (Min –Max values indicate the range of acceptable values)
5. Choose Expiration, Press OK,
6. Choose time from drop down menu using ▲ or ▼, press OK, press BACK
7. Choose OFF Set Point, Press OK
8. Enter value using ▲ or ▼ and NEXT to move to the next digit, press OK, press BACK
9. Choose Delay ON, Press OK
10. Enter value using ▲ or ▼ and NEXT to move to the next digit, press OK, press BACK
11. Choose Delay OFF, Press OK.
12. Enter value using ▲ or ▼ and NEXT to move to the next digit, press OK, and press BACK when done to exit Relay 1.
13. Repeat for Relay 2 and Relay 3.

4.4.4 Exit Menus and Return to Main Display

1. Press HOME Key to return to the Home Menu Screen
2. Press Hold to turn OFF Hold
3. Press EXIT Key to exit the menu
4. “Save Changes?” press YES
5. Choose Display Mode, **DATA**, **mV** or **GRAPH** by pressing the selection Key. The selection key displays which screen will be displayed next.
6. The type of graphical display used, Line, Bar or Gauge is selected in CONFIG → XMTR → LCD → GRAPH → LINE, GAUGE, BAR



4.4.5 Sensor Start Up

All sensors are supplied with protective caps over the sensing end. Remove the cap(s) from the sensor before installing in the process. All sensors were calibrated at the factory before shipment, no calibration should be necessary before use. Allow the sensor to equilibrate to the process solution conditions for ½ hour before verifying the reading against a grab sample. If calibration is required follow the instruction in Section 5 *Calibration* below.

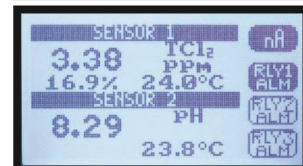

4.5 USER SELECTABLE OPTIONS

4.5.1 Screen Lighting

LED back lighting is available on AC and DC powered instruments only.

Contrast can be adjusted for optimal viewing. The Backlight can be adjusted to timeout after a set period of time or remain on.

Location: CONFIG → XMTR → LCD → Set Up → CONT, BACK LIGHT

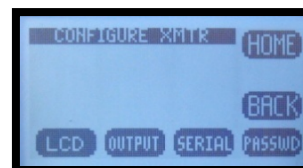

4.5.2 Graphical Display

There are three graphical display choices:

1. **LINE**, The Line graph is a moving average of the process variable with the 4-20 mA range as the maximum/minimum values and a choice of time scales.

The Time scale is the amount of time displayed across the full screen. Choices include:

Full Screen Period	15 minutes	1 hour	12 hours	1 day	2 days
Sample Rate (1 point every)	10 seconds	40 seconds	8 minutes	15 minutes	30 minutes

2. **GAUGE**, Live reading displaying 0-100% of 4-20 mA range. The Alarm Relay number(s), #1, #2 and #3 mark the respective set points on graph.
3. **BAR**, Live reading displaying 0-100% of 4-20 mA range. The Alarm Relay number(s), #1, #2 and #3 mark the respective set points on graph.

Pressing **OK** after selecting a Graphical Display will exit the menu structure and return to the Main Display.

Location: CONFIG → XMTR → LCD → GRAPH

4.5.3 TAG Transmitter Name

Two 16 character lines are available for naming the transmitter, Upper and Lower case characters, Numbers and Punctuation are available. The information entered will be displayed in the INFO screen and optionally in the Main display sequence if activated in the TAG ON menu. The character set is listed below sequentially; the first character in the set is an empty space.

! " # \$ % & ' () * + , - . / 0 1 2 3 4 5 6 7 8 9 : ; < = > ? @ A B C D
E F G H I J K L M N O P Q R S T U V W X Y Z [\] ^ _ ` a b c d e
f g h i j k l m n o p q r s t u v w x y z { | } → ←

Entry is accomplished by scrolling through the alphanumeric list with the ▲ (forward →) and ▼ (backwards ←) arrows to the character of choice and then pressing **NEXT** to advance the cursor to the next digit. Pressing and holding the ▲ or ▼ keys will initiate two speed auto scrolling. Press **BACK** to exit the screen.

Location: CONFIG → XMTR → LCD → LABELS → TAG

4.5.4 Sensor Name

Two 16 character lines are available for naming the Sensor, Upper and Lower case characters, Numbers and Punctuation are available. The information entered will be displayed in the INFO screen. Entry is accomplished by scrolling through the alphanumeric list with the ▲ (forward →) and ▼ (backwards ←) arrows to the character of choice and then pressing **NEXT** to advance the cursor to the next digit. Pressing and holding the ▲ or ▼ keys will initiate two speed auto scrolling. Press **BACK** to exit the screen.



Location: CONFIG → XMTR → LCD → LABELS → SENSOR

4.5.5 Password Protection

PASSWD: Enter 4 character password to protect access to MENU Level, CAL Menu, CONFIG Menu and SIM Menu (simulate). Each level can be turned ON or OFF and can have a unique password. Upper Case Characters and Numbers are available for use.

Place the cursor in front of the level to be changed and Press **OK**. Move the cursor to **ON** and press **OK** to change the password status from OFF to ON.

Entry is accomplished by scrolling through the alphanumeric list with the ▲ (forward →) and ▼ (backwards ←) arrows to the character of choice and then pressing **NEXT** to advance the cursor to the next digit. Pressing and holding the ▲ or ▼ keys will initiate two speed auto scrolling.

- **MENU** ON/OFF __ Locks Main Menu
- **CAL** ON/OFF __ Locks CAL and CONFIG
- **CONFIG** ON/OFF __ Locks CONFIG
- **SIM** ON/OFF __ Locks SIM and CONFIG



In the case of a **Lost or Forgotten password** enter **MSTR** to access the screen.



Location: CONFIG → XMTR → PSSWD

Calibration

5.1 Calibration Modes

The Model LXT-330 Transmitter provides three methods of calibration:

- Auto Calibration
- Standardize Calibration
- Manual Calibration

5.1.1 AUTO Calibration Description

Auto calibration is the primary calibration method for all measurements. AUTO calibration automatically recognizes the calibration solution the sensor is in and proposes the actual temperature compensated value for acceptance. AUTO calibration can be a single point or two point calibration. A single point calibration sets the zero point or offset value of the sensor. The second calibration sets the slope or span of the sensor.

When the AUTO key Cal 1 is pressed the transmitter displays the PV (Process Variable) and the associated mV signal from the sensor. When the reading has stabilized a calibration value is AUTOMATICALLY proposed, i.e. 0.00 mV 7.00 pH for pH, 0.00 mV 0.00 ppm for Total Chlorine. **The user is prompted to accept the proposed calibration value or enter and accept another value.** Once Cal 1 is accepted the user is asked to continue to Cal 2, yes/no. If yes, then a second calibration value is proposed when the sensor has stabilized in the second calibration solution. Accept the value and the calibration is complete.

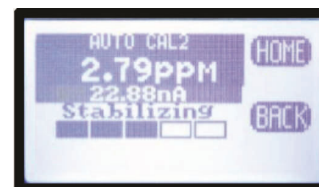

At the end of each calibration the Offset and Slope are displayed in the respective units, pH, mV, ppm, press OK to save the calibration and write it to the sensor’s memory.

5.1.2 STANDardize Calibration Description

A Standardize Calibration is a single point calibration where the transmitter’s reading is adjusted to agree with a solution of known value, either a calibration standard or a grab sample with a laboratory determined value. In many cases the constituents and the pressure and temperature of the process solution are very different from the calibration solution. In these cases, once the sensor has equilibrated to the process environment, the Zero Point or Offset value may have shifted from the original calibration point. Standardization allows for correction of this type of offset.

When the STAND key is pressed, the user is prompted to ENTER VALUE. The user enters the pH or Chlorine value they want the transmitter to read and press OK. The user is then prompted to accept the value, yes/no, and the calibration is complete. Standardizations are single point calibrations. It changes the Offset value in a pH calibration. **It changes the Slope value in a Total Chlorine calibration. It is the primary calibration for Total Chlorine.** Enter the Total Chlorine value determined by a DPD test on the process water.

At the end of each calibration the Offset and Slope are displayed in the respective units, pH, mV, ppm.

5.1.3 MANUAL Calibration description

Manual calibration allows the user to enter calibration data for an electrode into the transmitter without performing a calibration. A MANUAL Calibration requires the entry of three pieces of data, (1) A **concentration** with the (2) **corresponding mV** value and (3) a **slope** for the electrode. This allows laboratory generated calibration data for an electrode to be entered in a remote analyzer where calibration is difficult or impractical.

The pictures show a Manual Calibration for a 0-20 ppm Total Chlorine sensor using the default values of 0.00 ppm = 0.00 mV and 15 mV/ppm.

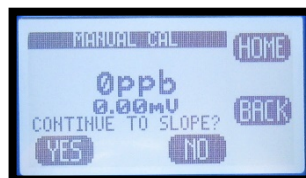
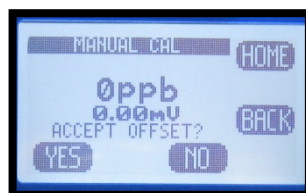
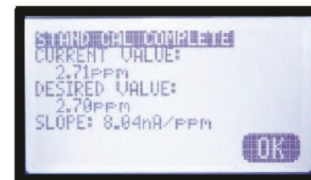
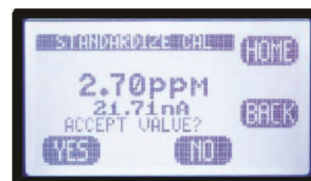

Example: MANUAL Calibration for a pH electrode:

1. Calibrate the pH electrode in the laboratory
2. Record the mV value of some pH Standard, pH 7.00 buffer = 6.8 mV (any pH – mV pair will work)
3. Calculate and Record the slope of the electrode, -58.2 mV/pH
4. Install the electrode into the field mounted sensor
5. Press **MANUAL** and enter the pH value, 7.00 pH, press **mV** and enter the corresponding mV value, 6.8 mV, press **OK**, Accept Offset?, press **YES**, enter slope -58.2 mV/pH, press **OK**, Accept Slope?, Press **YES**
6. The Calibration is complete, the Offset and Slope values are displayed, press **OK** to exit.

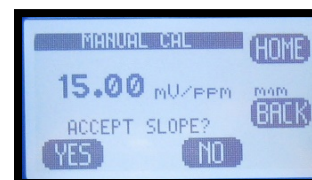
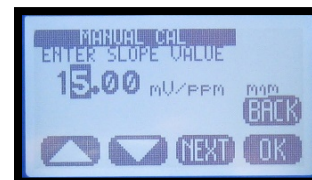

5.2 pH Calibration Procedures

AUTO Calibration recognizes pH 4.01, pH 7.00 and pH 10.00 buffer solutions for automatic, temperature compensated calibrations. Any calibration solutions can be used but the pH value will have to be entered manually. Follow the steps below to accomplish a pH calibration. Example uses pH 7.00 and pH 4.01 buffers.

5.2.1 AUTO Cal Using pH 4.01, 7.00, 10.00 buffers

Action	Prompt
Double Press any Button	MENU HOME, Hold is OFF
Press HOLD	Hold freezes 4-20 mA Output and locks Alarm Relays during Calibration
Press CAL	Is this a new Sensor? (Yes erases CAL Log in INFO, NO adds CAL to existing Log)
Press Yes/ NO	Place Sensor in CAL Solution (use pH 7.00 buffer)
Press AUTO then CAL 1	STABILIZING, 7.00 pH x.x mV, 7.00 pH corrected Accept Cal 1?

Press YES	CAL1 Value 7.00 pH, Continue to CAL2? Move sensor to 4.01 pH buffer solution
Press YES	STABILIZING, 4.00 pH xxx.x mV, 4.00 pH corrected Accept Cal?
Press YES	OFFSET: 7.00 pH x.x mV, SLOPE: -59.16 mV/pH (data written to Log)
Press OK	Calibration complete
Press HOME	Hold is ON
Press HOLD	Turn off Hold
Press EXIT	Main Display

5.2.2 AUTO Cal Using Other pH Buffers

Action	Prompt
Double Press any Button	MENU HOME, Hold is OFF
Press HOLD	Hold freezes 4-20 mA Output and locks Alarm Relays during Calibration
Press CAL	Is this a new Sensor? (Yes erases CAL Log in INFO, NO adds CAL to existing Log)
Press YES/NO	Place Sensor in CAL Solution
Press AUTO then CAL 1	STABILIZING, 6.86 pH 8.2 mV, 7.00 pH corrected Accept Cal?
Press NO	Enter CAL 1 Value
Press ▲▼NEXT	6.86 pH (use arrows and NEXT to enter pH Buffer value)
Press OK	6.86 pH, 8.2 mV, Accept this Value
Press YES	CAL 1 Value 6.86 pH, Continue to CAL 2? (Place Sensor in 2 nd calibration buffer)
Press YES	STABILIZING, 9.18pH 135.6 mV, 10.00 pH corrected Accept Cal?
Press NO	Enter CAL 2 Value
Press ▲▼NEXT	9.18 pH (use arrows and NEXT to enter pH Buffer value)

Press OK	9.18 pH, 135.6 mV, Accept this Value
Press YES	OFFSET: 6.86 pH 8.2 mV, SLOPE: -59.16 mV/pH (data written to Log)
Press OK	Calibration complete
Press HOME	Hold is ON
Press HOLD	Turn off Hold
Press EXIT	Main Display

5.2.3 Standardize

Leave the sensor in the process solution, take a grab sample from the process and determine the pH or place sensor in a calibration standard solution.

Action	Prompt
Double Press any Button	MENU HOME, Hold is OFF
Press HOLD	Hold freezes 4-20 mA Output and locks Alarm Relays during Calibration
Press CAL	Is this a new Sensor? (Yes, erases CAL Log in INFO, NO adds CAL to existing Log)
Press NO	Place Sensor in CAL Solution (or leave in the process solution)
Press STAND	Enter Value
Press ▲▼NEXT	xx.xx pH (use arrows and NEXT to enter process pH value)
Press OK	xx.xx pH, xxx.x mV, Accept Value?
Press YES	OFFSET: xx.xx pH x.x mV, SLOPE: xx.xx mV/pH (this data written to Log)
Press OK	Back to Cal Menu
Press HOME	Hold is ON (Press HOLD to turn off Hold)
Press HOLD	Turn off Hold
Press EXIT	Main Display

5.3 Total Chlorine Calibration Procedures

5.3.1 AUTO CAL

AUTO Calibration is an awkward calibration for the Total Chlorine sensor. It is the only way to enter the actual zero potential of the total chlorine sensor. The Slope calibration “Cal 2” is best accomplished in the Standardized menu, it is much easier and more straightforward.

AUTO Cal recognizes 0.00 ppm Total Chlorine solutions in Cal 1. The Zero point calibration is very consistent for a Total Chlorine sensor and should only be done after rebuilding or replacing the sensor. To perform a zero calibration either run chlorine free water through the flow cell or remove the sensor from the flow cell and place it in a beaker of dechlorinated water. The zero point calibration will take about an hour for a new or rebuilt sensor. Most sensors will burn down to a value of 0.1-0.2 mV, at this point accept the calibration and proceed to Cal 2. Cal 2 sets the slope of the sensor. It is accomplished by setting the ppm value of the instrument to agree with a DPD tested value of the water flowing through the TCA330 Analyzer. The analyzer will suggest a corrected value of 0.00 ppm, 5.00 ppm or 10.00 ppm, which will not be correct unless that happens to be the actual value of the sample water, Press NO and enter the value from the DPD test. The nominal value for the slope is 5.0 nA/ppm \pm 2 nA.

Action	Prompt
Double Press any Button	MENU HOME, Hold is OFF
Press HOLD	Hold freezes 4-20 mA Output and locks Alarm Relays during Calibration
Press CAL	Is this a new Sensor? (Yes erases CAL Log in INFO, NO adds CAL to existing Log)
Press Yes/ NO	Place FC Sensor in CAL 1 Solution (use 0.00 ppm solution) or go to CAL 2
	To perform zero CAL press CAL 1, to skip the zero Cal press CAL 2
Press AUTO then CAL 1	STABILIZING, 0.00 ppm, xxx.x mV, Accept Cal?

Press YES	CAL1 Value 0.00 ppm, 0.2 mV, OK?
Press OK	Feed chlorinated water to the FC80, run DPD test when the reading stabilizes. If the calibration times out and returns to the Home Screen, Press AUTO and select Cal 2.
Press YES	Continue to CAL2?
Press YES	STABILIZING, 2.25 ppm, 13.2 mV, 5.00 ppm corrected, Accept Cal?
Press NO	Enter Cal 2 Value, 2.25 ppm, Change value to the DPD tested value, OK?
Press OK	OFFSET: 0.00 ppm, 2.3 mV, SLOPE: 14.1 mV/ppm (data written to Log)
Press OK	Calibration complete
Press HOME	Hold is ON
Press HOLD	Turn off Hold
Press EXIT	Main Display

5.3.2 Standardize

The Standardize Calibration is the Primary method for calibrating the Total Chlorine sensor. It is the easiest and most straight forward method of calibration. Simply run a DPD test and enter the value in the entry screen.

Action	Prompt
Double Press any Button	MENU HOME, Hold is OFF
Press HOLD	Hold freezes 4-20 mA Output and locks Alarm Relays during Calibration
Press CAL	Is this a new Sensor? (Yes, erases CAL Log in INFO, NO adds CAL to existing Log)
Press NO	Place Sensor in the process solution,. Test Sample with DPD.
Press STAND	Enter Value

Press ▲▼NEXT	xxx.xx ppm (use arrows and NEXT to enter process value) OK?
Press OK	xxx.xx ppm, xxx.x mV, Accept Value?
Press YES	Current Value xx.xx, Desired Value xx.xx, Change xx.xx, OK?
Press OK	Back to Cal Menu
Press HOME	Hold is ON (Press HOLD to turn off Hold)
Press HOLD	Turn off Hold
Press EXIT	Main Display

5.3.3 Manual Cal

Manual Cal is a convenient way to reset the analyzer to default Status. Simply enter the actual zero point if it is known or 0.00 ppm = 00.0 nA and the default slope, 5 nA/ppm and the displayed value should be in the ballpark of the actual Total Chlorine value.

Action	Prompt
Double Press any Button	MENU HOME, Hold is OFF
Press HOLD	Hold freezes 4-20 mA Output and locks Alarm Relays during Calibration
Press CAL	Is this a new Sensor? (Yes, erases CAL Log in INFO, NO adds CAL to existing Log)
Press NO	Auto, Stand, Manual, Temp
Press MANUAL	Enter Zero Value
Press ▲▼NEXT	0.00 ppm (use arrows and NEXT to enter ppm value)
Press OK	OFFSET: 0.00 ppm, 0.2 mV, Accept Value?
Press YES	Enter Slope, 5.00 nA/ppm
Press ▲▼NEXT	5.00 nA/ppm
Press OK	Slope 5.00 nA/ppm, Accept this Value?
Press YES	Back to Cal Menu

Press HOME	Hold is ON (Press HOLD to turn off Hold)
Press HOLD	Turn off Hold
Press EXIT	Main Display

Blank Page

MAINTENANCE

The Model LXT-330 transmitter requires no periodic maintenance, except to make sure the front window is kept clean in order to permit a clear view of the display and allow proper operation of the navigation buttons. If the window becomes soiled, clean it using a soft damp cloth or soft tissue. To deal with more stubborn stains, a neutral detergent or spray cleaner like Windex may be used. Never use harsh chemicals or solvents.

When you open the front cover and/or cable glands, make sure that the seals are clean and correctly fitted when the unit is re-assembled in order to maintain the housing's NEMA 4X weatherproof integrity against water and water vapor.

6.1 Total Chlorine Sensor

Check the measurement at regular intervals, at least once a month. If the membrane is visibly soiled clean it with a jet of water or a dilute HCl solution between 1-5%. Do not clean with detergents or solvents that would reduce the surface tension of the membrane.

6.1.1 Removing or Replacing the Membrane

First, expose the vent hole on the cap by sliding the silicone band out of the groove. Failure to vent the sensor before removing the cap can destroy the membrane. Replace the membrane cap if heavily soiled or torn.

Remove the membrane cap by screwing it off of the body. Refill the new membrane cap with electrolyte as described below and reinstall the cap on the sensor.

6.1.2 Polishing the Cathode

Polish the cathode when re-commissioning the sensor after storage or whenever the membrane cap is replaced. Silver from the anode deposits on the cathode over time and must be removed. Hold the supplied blue polishing strip on

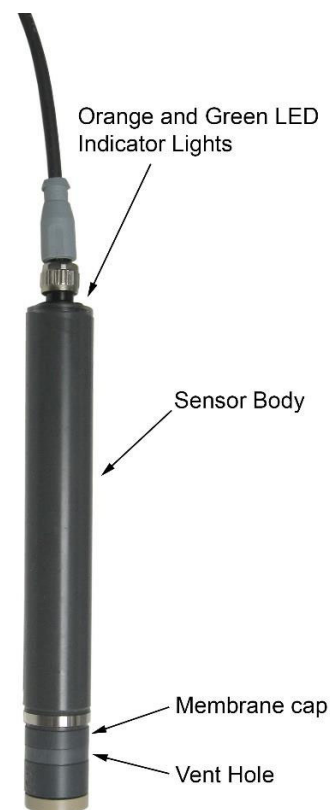

your finger tip and with the sensor held vertically, cathode facing up, gently wipe the strip across the cathode 2-3 times. This is an abrasive cleaning and does remove metal from the cathode shortening the sensors life. The cathode is 24 carat gold and after polishing it should look like 24 K gold not silvery like 10 K gold. Polishing Kit (P/N: K00336).

6.1.3 Refilling the Sensor

Refill the sensor with electrolyte (PN K00344) every three months or sooner depending on the chlorine level measured. The measured chlorine is reduced to chloride inside the cell and must be periodically removed. Samples with less than 5 ppm total chlorine require the sensor to be refilled every 3-4 months.

Lift the silicone band to expose the vent hole and unscrew the measuring cap from the sensor. Rinse out the spent solution with distilled water.

Fill the cap to the bottom of the threads with the gelled electrolyte and tap it gently to dislodge any trapped bubbles inside the cap.

Screw the sensor into the measurement cap at a 45° angle ensuring all air inside the chamber is purged through the vent hole on the side of the cap.

When the o-ring begins to seal continue slowly tightening until it hits the stop. Seal the silicone band back over the hole and rinse the purged electrolyte from the sensor body with water. The sensor is ready to use, re-polarize the sensor for 60 minutes before calibration.

6.1.4 Storage

The method for storage of the sensor is dependent on time.

For short term storage of several weeks the sensor can be stored filled inside the yellow protective cap as long as the membrane is not allowed to dehydrate. Make sure the sponge inside the cap is wetted. For longer terms rinse out the electrolyte with distilled water and allow the sensor to dry. Loosely reassemble the dry sensor so as not to tension the membrane during storage.

6.2 pH Sensor

All electrochemical sensors require periodic cleaning and/or replacement. The life of an electrode is dependent on the process conditions it is exposed to, a pH electrode may last a year or longer in potable water and only a few weeks in a hot caustic bath. The chemical

constituents in the process may coat the electrode surfaces requiring the electrode to be removed and cleaned or replaced.

Cleaning agents should be specific to the type of coating, detergents and alcohols for removing greases and oils, acids for removing hard water scales and metallic deposits or spray washing for flocculants and biofilms.

6.2.1 Electrode Cartridge Installation

Unless ordered separately, electrode cartridges are generally shipped installed in a sensor. Sensors ordered without an electrode are shipped with a shipping plug to keep contamination from getting inside the sensor during shipment or storage. The following procedure explains how to install the electrode cartridge in the sensor assembly:

1. Remove the shipping plug by turning it counterclockwise.
2. Remove the electrode cartridge from the protective soaker boot. *Be careful not to flex the electrode body while removing the tape and the protective boot.*
3. Rinse the electrode tip in tap water and wipe the electrode body dry then lubricate the O-ring seals with the included lubricant. *Save the protective soaker boot in the event the electrode must be stored at a future time.*
4. Carefully insert the electrode cartridge into the sensor assembly by turning until **hand tight**. The first O-ring, closest to the front of the electrode, will be slightly visible if held horizontally.

Note: If excess force is required during electrode installation, check for proper thread engagement or for an obstruction.

6.2.2 Electrode Cartridge Replacement

Periodic replacement of the electrode cartridge is required for pH, ORP and Specific Ion sensors. The following procedure explains how to replace the electrode cartridge in the sensor assembly:

1. Remove the shipping plug by turning it counterclockwise.
2. Remove the electrode cartridge from the protective soaker boot. *Be careful not to flex the electrode body while removing the tape and the protective boot.*
3. Rinse the electrode tip in tap water and wipe the electrode body dry then lubricate the o-ring seals with the included

lubricant. *Save the protective soaker boot in the event the electrode must be stored at a future time.*

4. Carefully insert the electrode cartridge into the sensor assembly by turning until **hand tight**. The first o-ring, closest to the front of the electrode, will be slightly visible if held horizontally.

Note: If excess force is required during electrode installation, check for proper thread engagement or for an obstruction.

6.2.3 Electrode Cleaning

An important aspect of sensor maintenance is the service of the electrode cartridge. After being in operation, an electrode may begin to exhibit slow response or non-reproducible measurements. This may be due to coating of the measurement electrode or clogging of the reference junction. Regular electrode cleaning reduces problems associated with the coating and clogging. Frequency of cleaning will depend on the process and application. The following procedures are used to clean pH and ORP electrodes.

If possible, the electrode should be cleaned without removing it from the sensor body. However, if the electrode must be removed, the o-rings must be inspected and re-lubricated.

6.2.4 pH Electrode Cartridge Cleaning

Remove the sensor from the process and carefully wash the wetted end of the electrode cartridge in a mild solution of detergent and water or with methyl alcohol. If the electrode response is not improved, soak the electrode in 0.1 Molar HCl for 5 minutes. Remove and rinse the electrode with tap water and soak in 0.1 Molar NaOH for 5 minutes.

Remove the electrode from the NaOH solution, rinse the electrode with copious amounts of tap water and soak in a 4 pH buffer solution for 10 minutes. This should improve the response of the electrode. If not, replace the electrode.

If the electrode must be left out of the process for an extended period of time, store it in a solution of water saturated with KCl or a 4.0 pH buffer solution. *Teledyne does not recommend the storage of electrodes in distilled or deionized water.*

6.3 Constant Head Flow Controller (CHFC)

The CHFC is designed to provide a constant flow to the Total Chlorine Sensor (TCS) independent of variations in the sample pressure. Decreasing the sample flow to the TCS will lower the output of the TCS. In most clean water applications the CHFC requires no maintenance. The vertical position of the central tube sets the Head Pressure of the system. It is set for optimal flow but lower flow rates can be attained by adjusting its height.

On a monthly basis visually inspect the CHFC, the interconnecting tubing and the drain tubing for obstructions or sediments that may reduce the flow. The CHFC and tubing can be easily disassembled and cleaned with soap and water. Some dirty applications like blowdown from Cooling Towers may require periodic cleaning due to sediments.

Blank Page

TROUBLESHOOTING

The TCA330 was evaluated and calibrated at the factory before shipment. Upon initial start up the system should require minimal to no adjustments.

Verify the system has adequate flow, greater than 10 gals /hr. This is accomplished by setting the flow to the CHFC so that the water fills the outer chamber and slightly overflows into the center tube. Verify the pH electrode and the temperature sensor are reading correctly. These parameters effect the measurement and must meet the standards listed in the Calibration Section above. If these conditions are met and problems still exist use the Troubleshooting Table to find a remedy.

7.1 Troubleshooting Guide

Table 7-1: Troubleshooting Guide

Symptom	Possible Cause	Remedy
Displayed value is Higher than DPD test value.	Insufficient Polarization time	Polarize TCS for full 90 minutes before calibration.
	Damaged Membrane Cap	Replace Membrane Cap
	pH indication higher than actual value	Calibrate pH sensor
	Temperature indication lower than actual value	The temperature sensor lags the process temperature wait for

	Electrical short or wet connection inside the sensor or cable assembly.	temperature equilibrium. Remove measuring chamber and dry the cathode surface, if the indication does not go to zero there is leakage. Replace the sensor.
Displayed value is Lower than DPD test value	Coated or dirty membrane Low tension on the membrane Flow to low through the flow cell Air bubbles trapped on membrane	Clean or replace the membrane Verify the Measuring Chamber is fully tightened onto the body or replace membrane. Clean CHFC, fittings and tubing, verify the sample feed rate is 10+ gal/hr. Loosen FCS fitting and lift sensor slightly to purge air trapped in the flow cell.
Displayed value is Lower than DPD test value (cont'd)	Air bubble inside the sensor between cathode and membrane	Refill sensor, see Maintenance

	<p>pH indication lower than actual value</p> <p>Temperature indication is higher than actual value.</p>	<p>Calibrate pH sensor</p> <p>Calibrate the Temperature (see Calibration) The temperature sensor lags the process temperature wait for temperature equilibrium.</p>
Zero Chlorine Reading	<p>No electrolyte in the sensor</p> <p>Open Circuit on TCS, broken or bad electrical connection</p>	<p>Refill Sensor</p> <p>Check connector and wiring to the connector inside the TCA330</p>
Unstable Chlorine Reading	<p>Air bubbles on the membrane</p> <p>Changing temperature, the lag of the temperature sensor looks like drift</p>	<p>Loosen TCS fitting and lift sensor slightly to purge air trapped in the flow cell.</p> <p>Wait for equilibrium</p>

<p>Green LED flickering or no light</p>	<p>Supply Voltage to low</p> <p>Defective Sensor</p>	<p>Verify 24V DC between the Blue and White sensor wires</p> <p>Return sensor to the manufacturer for reconditioning</p>
<p>Orange LED, Continuously ON</p> <p>Flickering</p>	<p>Wrong Polarity on signal wires</p> <p>Chlorine concentration to high, sensor over range</p>	<p>Verify Black #3, Yel/Grn #2</p> <p>Check for torn membrane, verify chlorine concentration, Recalibrate the sensor</p>

PARTS AND ACCESSORIES

8.1 TCA330 Replacement Parts

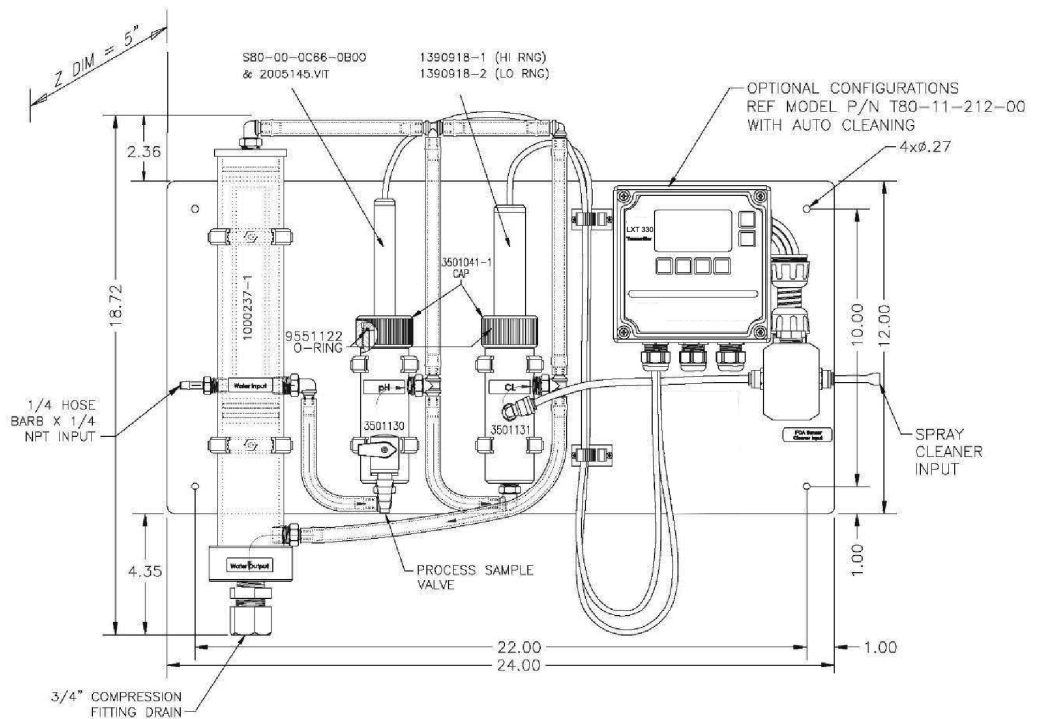

Part #	Description
S02165	NEW Total CL2 Sensor, 0.5 – 20.0 ppm Range (replaces S02166)
S02168	NEW Total CL2 Sensor, 0.005 – 2.0 ppm Range (replaces S02167)
S02166	OLD Total CL2 Sensor, 0.05 – 20.0 ppm Range (Units ordered before 2018)
S02167	OLD Total CL2 Sensor, 0.005 – 2.00 ppm Range (Units ordered before 2018)
K00342	NEW Membrane Kit 0-2/0-20 ppm (For S02165, S02168 Sensors)
K00343	NEW Membrane Kit 0-2/0-20 ppm SEAWATER (For S02165, S02168 Sensors)

K00345	Kit, Membrane & Electrolyte 0-2/0-20ppm (for S02165/S02168 Sensors)
K00346	Kit, Membrane & Electrolyte 0-2/0-20ppm SEA WATER (for S02165/S02168 Sensor)
K00344	Total CL2 Sensor Electrolyte Refill kit / Seawater, 50mL bottle
O00489	Silicone Band, (covers bleed hole in membrane cap)
CP03030	pH replacement electrode cartridge
S02051	pH Sensor, 316L SS body with Flange, 4' cable
F02879	Chlorine Flow Cell
F02861	pH Flow Cell
CP03809	Constant Head Flow Controller
CP03810	Constant Head Flow Controller, hi flow with fittings
K00268	Tube Fitting Set, complete set (9) 3/8" fittings (1) 1/4" fitting
TT00639	Kit, Tubing 3/8" PVC
K00336	Kit, Polishing

8.2 LXT-330 Front Panel Control Board Exploded

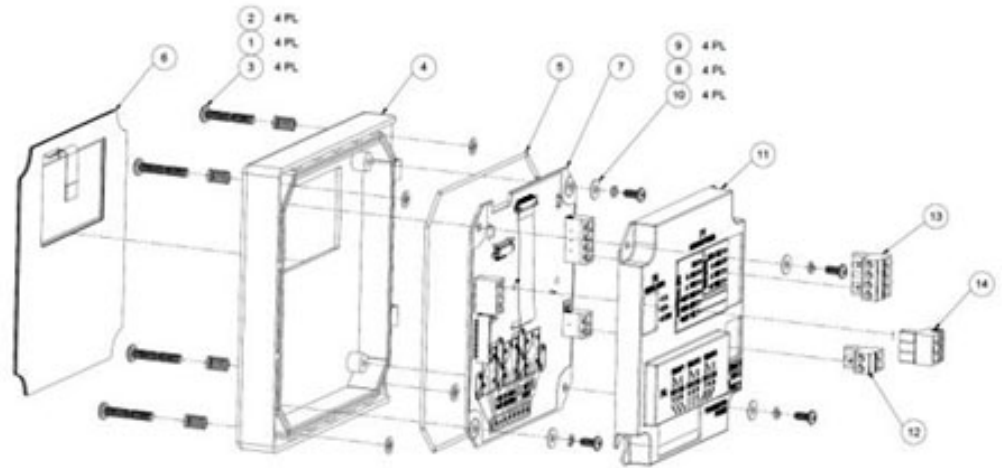

8.3 LXT-330 Front Panel Control Board Exploded, with Relays

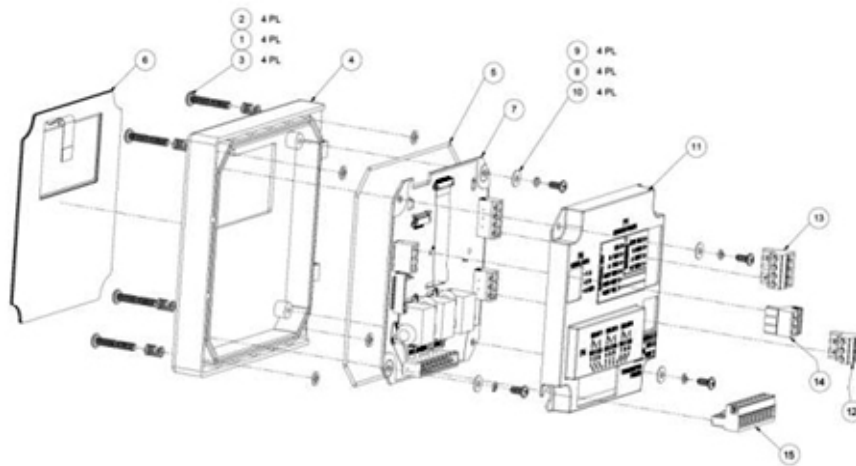

8.4 LXT-330 Transmitter Case, Back with Cable Glands

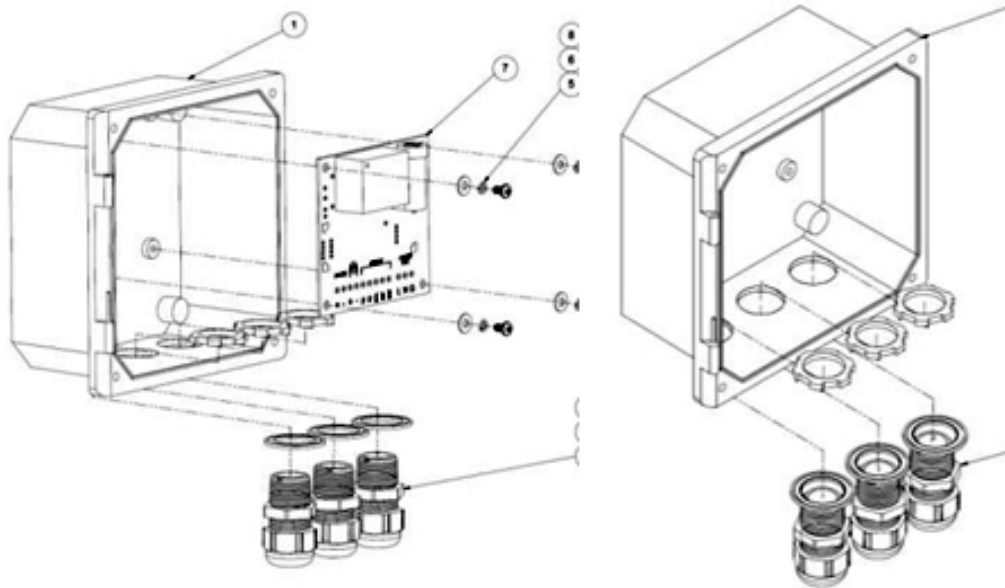

8.5 LXT-330 Replacement Parts

IMPORTANT: Orders for replacement parts should include the model number, serial number, and range of the analyzer for which the parts are intended.

Orders should be sent to:

TELEDYNE ELECTRONIC TECHNOLOGIES
Analytical Instruments

16830 Chestnut Street
City of Industry, CA 91748

Telephone: (626) 934-1500

Fax: (626) 961-2538

Web: www.teledyne-ai.com
or your local representative

email: ask_tai@teledyne.com

Blank Page

Appendix

A. Auto Cal Buffer Tables

°C	pH	pH	pH
0	4.00	7.115	10.32
5	4.00	7.085	10.25
10	4.00	7.06	10.18
15	4.00	7.04	10.12
20	4.00	7.015	10.06
25	4.005	7.00	10.01
30	4.015	6.985	9.97
35	4.025	6.98	9.93
40	4.03	6.975	9.89
45	4.045	6.975	9.86
50	4.06	6.97	9.83
55	4.075	6.97	
60	4.085	6.97	
65	4.10	6.98	
70	4.13	6.99	
75	4.14	7.01	
80	4.16	7.03	
85	4.18	7.05	
90	4.21	7.08	

B. MODBUS RTU Register Listing

03 (0x03) Read Holding Registers

This function code is used to read the contents of a contiguous block of holding registers in a remote device. The Request Protocol Data Unit specifies the starting register address and the number of registers. In the Protocol Data Unit Registers are addressed starting at zero. Therefore registers numbered 1-16 are address as 0-15.

The register data in the response message are packed as to bytes per register, with the binary contents right justified within each byte. For each register, the first byte contains the high order bits and the second contains the low order bits.

Request

Modbus ID (Slave Address)	1 Byte	1 to 247 (0x01 to 0xF7)
Function code	1 Byte	0x03
Starting Address	2 Bytes	0x0000 to 0xFFFF
Quantity of Registers	2 Bytes	1 to 125 (0x01 to 0x7D)
CRC	2 Bytes	calculated

Response

Modbus ID (Slave Address)	1 Byte	1 to 247 (0x01 to 0xF7)
Function code	1 Byte	0x03
Byte Count	1 Byte	2 X N*
Register Value(s)	*N X 2 Bytes	
CRC	2 Bytes	calculated
*N = Quantity of Registers		

Error

Modbus ID (Slave Address)	1 Byte	1 to 247 (0x01 to 0xF7)
Error Code	1 Byte	0x86
Exception Code	1 Byte	01, 02, 03 or 04
CRC	2 Bytes	calculated

06 (0x06) Write Single Register

This function code is used to write a single holding register in a remote device. The Request Protocol Data Unit specifies the address of the register to be written. Registers are addressed starting at zero. Therefore register number 1 is addressed as 0. The normal response is an echo of the request, returned after the register contents have been written.

Request

Modbus ID (Slave Address)	1 Byte	1 to 247 (0x01 to 0xF7)
Function code	1 Byte	0x06
Register Address	2 Bytes	0x0000 to 0xFFFF
Register Value	2 Bytes	0x0000 to 0xFFFF
CRC	2 Bytes	calculated

Response

Modbus ID (Slave Address)	1 Byte	1 to 247 (0x01 to 0xF7)
Function code	1 Byte	0x06
Register Address	2 Bytes	0x0000 to 0xFFFF
Register Value	2 Bytes	0x0000 to 0xFFFF
CRC	2 Bytes	calculated

*N = Quantity of Registers

Error

Modbus ID (Slave Address)	1 Byte	1 to 247 (0x01 to 0xF7)
Error Code	1 Byte	0x86
Exception Code	1 Byte	01, 02, 03 or 04
CRC	2 Bytes	calculated

REGISTERS

Per the Modbus Application Protocol Specification (V1.1b)

Name	Meaning (2 bytes each register)	Number of Registers	Return Data Format	Read Write	Requires Storage Initiate	Register #	
						dec	hex
Modbus ID (slave address)	Defined as 1 to 247 per the Modbus Application Protocol Specification (V1.1b)	1	16 bit Integer	RW		0	00
Data Format	Data Format of the User Bus to the LXT-330 (0-DF8N2, 1-DF8O1, 2-DF8E1, 3-DF8N1)	1	16 bit Integer	RW		1	01
Baud Rate	Baud Rate of the User Bus to the LXT-330 (0-1200, 1-2400, 2-4800, 3-9600)	1	16 bit Integer	RW		2	02
BusMessage	total message count detected by the slave (remote device)	1	16 bit Integer	R		3	03
BusCommunicationsError	total CRC error count	1	16 bit Integer	R		4	04
SlaveExceptionError	total count of exceptions detected	1	16 bit Integer	R		5	05
SlaveMessage	total messages addressed to the slave (remote device)	1	16 bit Integer	R		6	06
SlaveNoResponse	total count of messages not responded to by the slave (remote device)	1	16 bit Integer	R		7	07
SlaveNAK	total Negative Acknowledges returned by slave (remote device)	1	16 bit Integer	R		8	08
SlaveBusy	total count of "slave busy" was returned for an address message	1	16 bit Integer	R		9	09
BusCharacterOverrun	count of messages that couldn't be handled due to character over-run condition	1	16 bit Integer	R		10	0A
Reset all Modbus Error Counters	Resets all of the Modbus Error counters (defined in Modbus spec) to 0, Write any value.	1	16 bit Integer	W		11	0B
Product LXT-330 Model Number (Modbus)	The Model Number of the Unit polled	1	16 bit Integer	R		12	0C
LXT-330 Serial Number (hi word)	Unit Serial Number (32 bit integer hi word, bytes 3 and 2)	2	32 bit Long Integer	R		13	0D
LXT-330 Serial Number (lo word)	Unit Serial Number (32 bit integer lo word, bytes 1 and 0)					14	0E
LXT-330 Mode	Unit operating mode (1-Startup, 2-Sensor Search, 3-Operate)	1	16 bit Integer	R		15	0F
LXT-330 Fault Status	Unit Fault flags, bit defined	1	16 bit Integer	R		16	10
LXT-330 2nd Fault Status	Unit Fault flags (2nd word reserved, currently not used)	1	16 bit Integer	R		17	11
LXT-330 Warning Status	Unit Warning flags, bit defined	1	16 bit Integer	R		18	12
LXT-330 2nd Warning Status	Unit Warning flags (2nd word reserved, currently not used)	1	16 bit Integer	R		19	13
LXT-330 FW Rev	Firmware revision of the Control BD in ASC, ex. " 1".	1	16 bit Integer	R		20	14
Relay Number to read/write	Relay number to access data (0 - Relay 1, 1 - Relay 2, 2 - Relay 3)	1	16 bit Integer	RW		21	15
Relay Type	Read/Write Relay Type (0 - Fault Type, 1 - Alarm Type, 2 - Disabled, 3 - Timed)	1	16 bit Integer	RW	Y	22	16
Relay ON Setpoint (hi word)	Read/Write Relay ON Setpoint (byte 3 and byte 2)	2	32 bit floating Point	RW	Y	23	17

Relay ON Setpoint (lo word)	Read/Write Relay ON Setpoint (byte 1 and byte 0)					24	18
Relay OFF Setpoint (hi word)	Read/Write Relay OFF Setpoint (byte 3 and byte 2)	2	32 bit Floating Point	RW	Y	25	19
Relay OFF Setpoint (lo word)	Read/Write Relay OFF Setpoint (byte 1 and byte 0)					26	1A
Relay ON Delay (hi word)	Read/Write Relay turn on Delay time (byte 3 and byte 2)	2	32 bit Floating Point	RW	Y	27	1B
Relay ON Delay (lo word)	Read/Write Relay turn on Delay time (byte 1 and byte 0)					28	1C
Relay OFF Delay (hi word)	Read/Write Relay turn off Delay time (byte 3 and byte 2)	2	32 bit Floating Point	RW	Y	29	1D
Relay OFF Delay (lo word)	Read/Write Relay turn off Delay time (byte 1 and byte 0)					30	1E
Relay Energized State	Read/Write Relay 0 - Energized, 1 - De-Energized	1	16 bit Integer	RW	Y	31	1F
Relay Expiration	Read/Write Expiration Time, used with alarm type (0 - None, 2 - 5min., 3 - 10min., 4 - 15min., 6 - 30min.)	1	16 bit Integer	RW	Y	32	20
Relay Period	Read/Write Timed Relay Period (0 - 15min., 1 - 30min., 2 - 1hr., 3 - 2hr., 4 - 4hr., 5 - 8hr., 6 - 24hr.)	1	16 bit Integer	RW	Y	33	21
Relay Duration	Read/Write Timed Relay Duration (0 - 15sec., 1 - 30sec., 2 - 1min., 3 - 2min., 4 - 5min., 5 - 15min., 6 - 10min.)	1	16 bit Integer	RW	Y	34	22

Relay Hold Time	Read/Write Timed Relay Hold Time (0 - Off, 1 - held for the duration time, 2 - duration + 15sec., 3 - duration + 30sec., 4 - duration + 1min., 5 - duration + 2min., 6 - duration + 5 min., 7 - duration + 15min., 8 - duration + 30min.)	1	16 bit Integer	RW	Y	35	23
4-20 mA Channel Number to read/write	4-20 mA channel number to access data (0 - 1st 4-20mA, 1 - 2nd 4-20)	1	16 bit Integer	RW	Y	36	24
4-20 Analog Type	Read/Write 4-20 Type (0 - Range, 1 - Temperature, 2 - Sentinel)	1	16 bit Integer	RW	Y	37	25
4-20 Analog Range, 4mA range (hi word)	Read/Write 4mA range (bytes 3 and 2) applies to both range and temperature types	2	32 bit Floating Point	RW	Y	38	26
4-20 Analog Range, 4mA range (lo word)	Read/Write 4mA range (bytes 1 and 0) applies to both range and temperature types					39	27
4-20 Analog Range, 20mA range (hi word)	Read/Write 4mA range (bytes 3 and 2) applies to both range and temperature types	2	32 bit Floating Point	RW	Y	40	28
4-20 Analog Range, 20mA range (lo word)	Read/Write 4mA range (bytes 1 and 0) applies to both range and temperature types					41	29
Long Tag Line number to read/write	Tag Line number to access data (0 - Line 1, 1 - Line 2)	1	16 bit Integer	RW	Y	42	2A
Long Tag Line 1 (16 characters max)	ASCII character bytes 0 and 1, ex. "AB" A - 65 (41 hexadecimal), B - 66 (42 hex), send 6566 (4142 hex). The characters permitted are space ' ' (32 base 10, 20 hex) through '}' 125 base 10, 7D hex).	1	16 bit Integer	RW	Y	43	2B
Long Tag Line	ASCII bytes 2 and 3	1	16 bit Integer	RW	Y	44	2C
Long Tag Line	ASCII bytes 4 and 5	1	16 bit Integer	RW	Y	45	2D
Long Tag Line	ASCII bytes 6 and 7	1	16 bit Integer	RW	Y	46	2E

Long Tag Line	ASCII bytes 8 and 9	1	16 bit Integer	RW	Y	47	2F
Long Tag Line	ASCII bytes 10 and 11	1	16 bit Integer	RW	Y	48	30
Long Tag Line	ASCII bytes 12 and 13	1	16 bit Integer	RW	Y	49	31
Long Tag Line	ASCII bytes 14 and 15	1	16 bit Integer	RW	Y	50	32
Initiate LXT-330 Parameter Storage	Signals the user has completed entering the data and wants it stored. Write any value.	1	16 bit Integer	RW		51	33
Sensor Channel to read/write	Sensor channel number to access data (0 - Sensor 1, 1 - Sensor 2)	1	16 bit Integer	RW		52	34
SP3 Mode	Unit operating mode (0-	1	16 bit Integer	R		53	35
SP3 Serial Number (hi word)	Unit Serial Number (32 bit integer hi word)	2	32 bit Long Integer	R		54	36
SP3 Serial Number (lo word)	Unit Serial Number (32 bit integer lo word)					55	37
SP3 Fault Status		1	16 bit Integer	R		56	38
SP3 Sensor Type	Specific SP3 sensor type (see SP3 Sensor Types tab)	1	16 bit Integer	R		57	39
SP3 Sensor Chemical Type	Specific chemicals the SP3 is set to detect (see SP3 Sensor Types tab)	1	16 bit Integer	RW	Y	58	3A
SP3 Max Range (hi word)	Max sensor range (bytes 3 and 2)	2	32 bit Floating Point	R		59	3B
SP3 Max Range (lo word)	Max sensor range (bytes 1 and 0)					60	3C
SP3 Min Range (hi word)	Min sensor range (bytes 3 and 2)	2	32 bit Floating Point	R		61	3D
SP3 Min Range (lo word)	Min sensor range (bytes 1 and 0)					62	3E
SP3 Sensor Value (hi word)	Current sensor value (bytes 3 and 2)	2	32 bit Floating Point	R		63	3F
SP3 Sensor Value (lo word)	Current sensor value (bytes 1 and 0)					64	40
SP3 Sensor Voltage (hi word)	Corresponding sensor voltage to the sensor value (byte 3 and byte 2)	2	32 bit Floating Point	R		65	41
SP3 Sensor Voltage (lo word)	Corresponding sensor voltage to the sensor value (byte 1 and byte 0)	2	32 bit Floating Point	R		66	42
SP3 Sensor Temperature (hi word)	Sensor Temperature (bytes 3 and 2)	2	32 bit Floating Point	R		67	43
SP3 Sensor Temperature (lo word)	Sensor Temperature (bytes 1 and 0)					68	44
SP3 Sensor is a Sentinel	Sensor is a Sentinel Type (0 - No, 1 - Yes)	1	16 bit Integer	R		69	45
SP3 Sentinel Life %	% of Sensor life remaining	1	16 bit Integer	R		70	46

SP3 Sentinel Vs (hi word)	Scaled Sentinel Voltage (in mV) normalized to Vo (bytes 3 and 2)	2	32 bit Floating Point	R		71	47
SP3 Sentinel Vs (lo word)	Scaled Sentinel Voltage (in mV) normalized to Vo (bytes 1 and 0)					72	48
SP3 Sentinel Vo (hi word)	Sentinel 100% value (in mV) on the life relative to 0V (bytes 3 and 2)	2	32 bit Floating Point	RW	Y	73	49
SP3 Sentinel Vo (lo word)	Sentinel 100% value (in mV) on the life relative to 0V (bytes 1 and 0)					74	4A
SP3 Sentinel Range (hi word)	Sentinel Range (bytes 3 and 2)	2	32 bit Floating Point	RW	Y	75	4B
SP3 Sentinel Range (lo word)	Sentinel Range (bytes 1 and 0)					76	4C
Sensor Full Name (18 characters max)	ASCII character bytes 0 and 1, ex. "AB" A - 65 (41 hexadecimal), B - 66 (42 hex), send 6566 (4142 hex). The characters permitted are space ' ' (32 base 10, 20 hex) through '}' 125 base 10, 7D hex).	1	16 bit Integer	RW	Y	77	4D
Sensor Full Name	ASCII bytes 2 and 3	1	16 bit Integer	RW	Y	78	4E
Sensor Full Name	ASCII bytes 4 and 5	1	16 bit Integer	RW	Y	79	4F
Sensor Full Name	ASCII bytes 6 and 7	1	16 bit Integer	RW	Y	80	50
Sensor Full Name	ASCII bytes 8 and 9	1	16 bit Integer	RW	Y	81	51
Sensor Full Name	ASCII bytes 10 and 11	1	16 bit Integer	RW	Y	82	52
Sensor Full Name	ASCII bytes 12 and 13	1	16 bit Integer	RW	Y	83	53
Sensor Full Name	ASCII bytes 14 and 15	1	16 bit Integer	RW	Y	84	54
Sensor Full Name	ASCII bytes 16 and 17	1	16 bit Integer	RW	Y	85	
Sensor Abbreviated Name (8 characters max)	ASCII character bytes 0 and 1, ex. "AB" A - 65 (41 hexadecimal), B - 66 (42 hex), send 6566 (4142 hex). The characters permitted are space ' ' (32 base 10, 20 hex) through '}' 125 base 10, 7D hex).	1	16 bit Integer	RW	Y	86	56
Sensor Abbreviated Name	ASCII bytes 2 and 3	1	16 bit Integer	RW	Y	87	57
Sensor Abbreviated Name	ASCII bytes 4 and 5	1	16 bit Integer	RW	Y	88	58
Sensor Abbreviated Name	ASCII bytes 6 and 7	1	16 bit Integer	RW	Y	89	59
Initiate SP3 Storage	Signals the user has completed entering the data and wants it stored. Write any value.	1	16 bit Integer	W		90	5A
Cal log number to read	Cal log number to read (0 - Cal Log 1, 1 - Cal Log 2, 2 - Cal Log 3)	1	16 bit Integer	RW		91	5B
SP3 Cal Log slope (hi word)	(bytes 3 and 2)	2	32 bit Floating Point	R		92	5C
SP3 Cal Log slope (lo word)	(bytes 1 and 0)					93	5D
SP3 Cal Log offset (hi word)	(bytes 3 and 2)	2	32 bit Floating Point	R		94	5E
SP3 Cal Log offset (lo word)	(bytes 1 and 0)					95	5F
SP3 Cal Log offset Voltage (hi word)	(bytes 3 and 2)	2	32 bit Floating Point	R		96	60
SP3 Cal Log offset Voltage (lo word)	(bytes 1 and 0)					97	61

FAULT STATUS

Bit #	bit meaning
0	Memory Error, either a Program Flash, RAM or NVM RAM checksum error has occurred
1	Input Voltage Out Of Tolerance
2	The On Board +12V is Out of Tolerance
3	The On Board +3.3V is Out of Tolerance
4	The Transmitter has lost communication link with the Sensor
5	There is no Sensor connected
6	Sensor Calibration Failed
7	Relay 1 on-time expired
8	Relay 2 on-time expired
9	Relay 3 on-time expired
10	Sentinel Error (useable life has expired)
11	Sentinel Poisoned
12	Membrane Error
13	NU
14	NU
15	NU

WARNING STATUS

Bit #	bit meaning
0	The Sensor has changed from previously connect Sensor
1	Not Used (NU)
2	NU
3	NU
4	NU
5	NU

Bit #	Bit Meaning
6	NU
7	NU
8	NU
9	NU
10	NU
11	NU
12	NU
13	NU
14	NU
15	NU

SENSOR TYPE

Data		Meaning		
Decimal	Hexadecimal	Chemical	Sensor Type	Measurement Units
0	0000	Unknown Chemical	None	None
1	0001	Ammonia	mV	ppm
2	0002	Ammonium	mV	ppm
3	0003	Bromide	mV	ppm
4	0004	Calcium	mV	ppm
5	0005	Chloride	mV	ppm
6	0006	Conductivity	Conductivity	S
7	0007	Cupric	mV	ppm
8	0008	Cyanide	mV	ppm
9	0009	DO	mV	ppm
10	000A	DO	mV	% saturation
11	000B	DO	mV	mg/L

12	000C	Fluoride	mV	ppm
13	000D	Hardness (CaCO ₃)	mV	ppm
14	000E	Nitrate	mV	ppm
15	000F	ORP	mV	mVa
16	0010	pH	mV	none
17	0011	Potassium	mV	ppm
18	0012	Resistivity	Conductivity	Ohm (W)
19	0013	Silver	mV	ppm
20	0014	Sodium	mV	ppm
21	0015	Sulfide	mV	ppm
22	0016	Turbidity	TR86	FNU
23	0017	Turbidity	TR86	NTU
24	0018	Turbidity	TR86	ppm
25	0019	Turbidity	TR86	mg/L
26	001A	Turbidity	TR86	% solid
27	001B	DO	DO82	ppm
28	001C	DO	DO82	% saturation
29	001D	DO	DO82	mg/L
30	001E	Calcium	mV	mg/L
31	001F	TDS	Conductivity	ppm
32	0020	Nitrite	mV	ppm
33	0021	TCA (max range)	TCA	mg/L
34	0022	TCA (min range)	TCA	mg/L
35	0023	TCA (max range)	TCA	mg/L
36	0024	TCA (min range)	TCA	mg/L
37	0025	TCA HR	TCA	mg/L
38	0026	Resistivity	Resistivity	ohm
39	0027	Conductivity	Conductivity	S
40	0028	PAA (mid range)	PAA	mg/L

41	0029	Lead	mV	mg/L
42	002A	Salinity	Conductivity	PSU
43	002B	Ozone (min range)	OZ	mg/L
44	002C	Ozone (max range)	OZ	mg/L
45	002D	HP (low range)	HP	mg/L
46	002E	HP (high range)	HP	mg/L
47	002F	HP (low percent)	HP	%
48	0030	HP (high percent)	HP	%
49	0031	Hardness	mV	Gr
50	0032	H2SO4 (low percent)	H2SO4	%
51	0033	H2SO4 (mid percent)	H2SO4	%
52	0037	H2SO4 (max percent)	H2SO4	%
53	0035	PAA (low range)	PAA	mg/L
54	0036	PAA (max range)	PAA	mg/L
55	0037	Nickel	mV	mg/L
56	0038	NaOH	Conductivity	%
57	0039	FCL (max range)	FCL	mg/L
58	003A	Cadmium	mV	mg/L

C. AUTO SPRAY CLEANER

The TCA330 is available with an automatic spray cleaner. The cleaning cycle is controlled by Alarm Relay 1 which is configured as a TIMED relay. The default settings are a 1 hour period, 1 minute duration and the HOLD function ON for the duration plus 30 seconds. The relay actuates a solenoid that feeds high pressure air or water to the chlorine flow cell. The turbulence blasts away any biofilms or soft precipitating coatings from the sensors, flow cells and lines. The greatest turbulence is in the Chlorine flow cell but both flow cells are agitated as are the feed lines. The duration and period of the cleaning cycle can be easily adjusted to suit the needs of the installation. (See section 4.4.3

Configuring Alarm Relays)

1. Remove the ¼" polypropylene tube from the John Guest fitting on the right side of the solenoid cleaner enclosure.
2. Provide 20-40 psi water or air to the ¼" John Guest fitting.

D. DC330 DE-CHLORINATION ANALYZER

The following two paragraphs were extracted from “EPA Wastewater Technology Fact Sheet Dechlorination,” EPA 832-F-00-022:

At present, few options exist for reliable long-term measurement of sulfite salts or close to-zero levels of residual chlorine in the finished effluent (ASCE and WEF, 1991). In recent practice, the only viable method for continuous residual chlorine measurement has been the amperometric technique, but this suffers from loss of accurate calibration at low concentrations (Finger et al., 1985)... For these reasons, control of dechlorination— particularly dechlorination to zero residual—has been problematic. Treatment plant operators have had to work around this limitation using various control strategies.

One commonly used strategy is the use of a “zero shifted” or “biased” analyzer (WEF, 1996; Nagel, 1994). In this scheme, a residual chlorine analyzer is used and a known concentration, X, of chlorine is added to the effluent sample to be analyzed. In this technique, the “zero” point is shifted by the value of X, and residual chlorine or sulfur dioxide can be inferred from the result of sample analysis.

The Teledyne Model DC330 De-Chlorination Analyzer uses the “zero shifted” strategy. The DC330 Total Chlorine Analyzer is fitted with a chlorine dosing pump that feeds into the outfall of the Constant Head Flow Controller and an “Offset” feature to accomplish the “zero point shift”.



E. DCA330 START UP PROCEDURES

Complete all Installation steps in Section 3 *Installation*. This includes mounting the panel, supplying power, wiring the outputs and filling and installing the sensors. The DCA330 was calibrated at the factory before shipping.

The Chlorine dosing pump is designed to supply approximately 5 ppm of chlorine to the measurement system using a 10:1 dilution of standard household bleach, 6-8% sodium hypochlorite. The peristaltic pump speed is scaled 0-100 with 40-50 providing the optimal speed to supply 5 ppm. The speed setting of 50 uses 1 liter of diluted chlorine solution per day. That equates to 3 days and 21 hours per gallon of solution, 5 gallons is 19 days.

Dilute a volume of bleach and place it in an opaque plastic container. Protect the diluted solution from light. Light degrades chlorine, turning it into sodium chloride. Insert the 4mm (0.167") tubing from the peristaltic pump into the bleach solution. It is best to drill a hole in the containers cap slightly larger than 4mm to keep the tubing in place and to allow air to enter as the solution is pumped out.

Supply chlorinated water to the TCA330 and allow the reading to stabilize for at least 2 hours. The analyzer should display some non-zero value, 1-3 ppm is a good range. When the reading has stabilized record the reading and start the chlorine feed by setting the pump speed to 50. It will take a minute or two for the chlorine to reach the injection point. The reading will jump up to around 5 ppm + the 1-3 ppm background value. Adjust the pump speed to generate a chlorine level exactly 5 ppm higher than the background value.

Remove the chlorinated sample stream from the TCA330 and connect the dechlorinated water to the Constant Head Flow Controller. The Analyzer will display a value near 5 ppm, higher if chlorine is present in the sample stream or lower if sulfite is in excess.

To use the OFFSET feature go to MENU > CONFIG > MORE > OFFSET. Enter **-5 ppm** or negative whatever ppm value you are adding, press OK > HOME > EXIT > SAVE > YES. The analyzer will now display 0.00 ppm plus any chlorine present or -X.XX ppm if the reducing agent (sulfite) is in excess.