

OPERATION & MAINTENANCE MANUAL

MODEL 6650SP-XD

Use and Disclosure of Data
Information contained herein is classified as EAR99 under the U.S. Export Administration Regulations. Export, reexport or diversion contrary to U.S. law is prohibited.

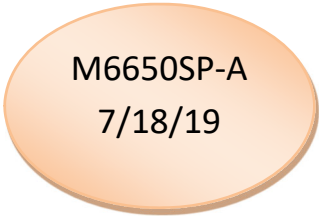
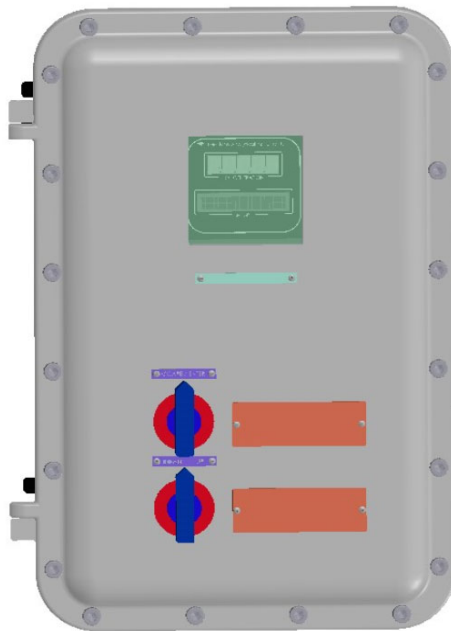

 **DANGER** 

Toxic and/or flammable gases or liquids may be present in this monitoring system. Do not introduce any flammable or toxic gases into this instrument.

Hazardous voltages exist on certain components internally which may be lethal. Disconnect power before servicing.

Only authorized personnel should conduct maintenance and/or servicing. Before conducting any maintenance or servicing, consult with authorized supervisor/manager.

DECLARATION OF CONFORMITY

This declaration of conformity is issued under the sole responsibility of the manufacturer

APPLICATION OF COUNCIL DIRECTIVE : 2014/34/EU

STANDARDS TO WHICH CONFORMITY IS DECLARED : EN 60079-0 : 2012+A11:2013
(IEC 60079-0 : 2011)
EN 60079-1 : 2014
(IEC 60079-1 : 2014-06)

MANUFACTURER'S NAME : TELEDYNE ANALYTICAL INSTRUMENTS

MANUFACTURER'S ADDRESS : 16830 Chestnut Street
City of Industry, CA 91748
U.S.A.

TYPE OF EQUIPMENT : 6650SP Oil in Water Analyzer
Explosion Proof

EQUIPMENT CLASS : Ex II 2 G Ex db IIB+H2 T6 Gb
-20°C ≤ Ta ≤ +60°C

MODEL NUMBER : 6650SP

I, THE UNDERSIGNED, HEREBY DECLARE THAT THE EQUIPMENT SPECIFIED ABOVE CONFORMS TO THE ABOVE STANDARD(S) PER 2014/34/EU and have been type-approved by Intertek Testing & Certification Limited, Intertek House, Cleeve Road, Leatherhead, Surrey, KT22 7SB. Intertek notified body identification number: 0359. Mark: Ex II 2 G. Code: Ex db IIB+H2 T6 Gb.

EC Type Certificate Number: ITS16ATEX18456X

IECEX Certificate Number: IECEX ITS 16.0029X

SIGNATURE: 

FULL NAME: Roger Starlin

POSITION: QA Manager

Date: 7-27-18

PLACE: City of Industry, California

SIGNATURE: 

FULL NAME: Angel Alegria

POSITION: New Products Manager

Date: 7-27-18

PLACE: City of Industry, California

Special Conditions for Safe Use

- **Due to window, the unit shall only be located in an area of low impact.**
- **Suitably certified Ex d IIB+H2 Gb cable glands, thread adapters and blanking elements must be untied.**

MODEL 6650SP-XD, UV Fluorescence, OIW Analyzer

Copyright © 2006 Teledyne Analytical Instruments

All Rights Reserved. No part of this manual may be reproduced, transmitted, transcribed, stored in a retrieval system, or translated into any other language or computer language in whole or in part, in any form or by any means, whether it be electronic, mechanical, magnetic, optical, manual, or otherwise, without the prior written consent of Teledyne Analytical Instruments, 16830 Chestnut Street, City of Industry, CA 91749-1580.

Warranty

This equipment is sold subject to the mutual agreement that it is warranted by us free from defects of material and of construction, and that our liability shall be limited to replacing or repairing at our factory (without charge, except for transportation), or at customer plant at our option, any material or construction in which defects become apparent within one year from the date of shipment, except in cases where quotations or acknowledgements provide for a shorter period. Components manufactured by others bear the warranty of their manufacturer. This warranty does not cover defects caused by wear, accident, misuse, neglect or repairs other than those performed by Teledyne or an authorized service center. We assume no liability for direct or indirect damages of any kind and the purchaser by the acceptance of the equipment will assume all liability for any damage which may result from its use or misuse.

We reserve the right to employ any suitable material in the manufacture of our apparatus, and to make any alterations in the dimensions, shape or weight of any parts, in so far as such alterations do not adversely affect our warranty.

Important Notice

This instrument provides measurement readings to its user and serves as a tool by which valuable data can be gathered. The information provided by the instrument may assist the user in eliminating potential hazards caused by his process; however, it is essential that all personnel involved in the use of the instrument or its interface, with the process being measured, be properly trained in the process itself, as well as all instrumentation related to it.

The safety of personnel is ultimately the responsibility of those who control process conditions. While this instrument may be able to provide early warning of imminent danger, it has no control over process conditions, and it can be misused. In particular, any alarm or control systems installed must be tested and understood, both as to how they operate and as to how they can be defeated. Any safeguards required such as locks, labels, or redundancy, must be provided by the user or specifically requested of Teledyne at the time the order is placed.

Therefore, the purchaser must be aware of the hazardous process conditions. The purchaser is responsible for the training of personnel, for providing hazard warning methods and instrumentation per the appropriate standards, and for ensuring that hazard warning devices and instrumentation are maintained and operated properly. Teledyne Analytical Instruments, the manufacturer of this instrument, cannot accept responsibility for conditions beyond its knowledge and control. No statement expressed or implied by this document or any information disseminated by the manufacturer or its agents, is to be construed as a warranty of adequate safety control under the user's process conditions.

SAFETY MESSAGES

Your safety and the safety of others is very important. We have provided many important safety messages in this manual. Please read these messages carefully.

A safety message alerts you to potential hazards that could hurt you or others. Each safety message is associated with a safety alert symbol. These symbols are found in the manual and inside the instrument. The definition of these symbols is described below:



GENERAL WARNING/CAUTION: Refer to the instructions for details on the specific danger. These cautions warn of specific procedures which if not followed could cause bodily injury and/or damage the instrument.



CAUTION: HOT SURFACE WARNING: This warning is specific to heated components within the instrument. Failure to heed the warning could result in serious burns to skin and underlying tissue.



WARNING: ELECTRICAL SHOCK HAZARD: Dangerous voltages appear within this instrument. This warning is specific to an electrical hazard existing at or nearby the component or procedure under discussion. Failure to heed this warning could result in injury and/or death from electrocution.



Technician Symbol: All operations marked with this symbol are to be performed by qualified maintenance personnel only. **NOTE:** Additional information and comments regarding a specific component or procedure are highlighted in the form of a note.

THE ANALYZER SHOULD ONLY BE USED FOR THE PURPOSE AND IN THE MANNER DESCRIBED IN THIS MANUAL.

CAUTION:



IF YOU USE THE ANALYZER IN A MANNER OTHER THAN THAT FOR WHICH IT WAS INTENDED, UNPREDICTABLE BEHAVIOR COULD RESULT POSSIBLY ACCOMPANIED WITH HAZARDOUS CONSEQUENCES.

MODEL 6650SP-XD, UV Fluorescence, OIW Analyzer

This manual provides information designed to guide you through the installation, calibration and operation of your new analyzer. Please read this manual and keep it available.

Occasionally, some instruments are customized for a particular application or features and/or options added per customer requests. Please check the front of this manual for any additional information in the form of an Addendum which discusses specific information, procedures, cautions and warnings that may be specific to your instrument.

Manuals do get misplaced. Additional manuals can be obtained from Teledyne at the address given in the Appendix. Some of our manuals are available in electronic form via the internet. Please visit our website at: www.teledyne-ai.com

If there are any questions concerning this equipment, please contact your local TAI representative, or the factory directly at:

TABLE OF CONTENTS

SAFETY MESSAGES	3
ADDITIONAL SAFETY INFORMATION	6
ATEX CERTIFIED PRODUCT	6
UNPACKING THE INSTRUMENT	6
1. THEORY OF OPERATION	7
1.1 INTRODUCTION OF FLUORESCENCE BACKGROUND	7
1.2 MAJOR COMPONENTS	9
2. CONTROL UNIT & SETUP FUNCTIONS	11
2.1 BRIEF DISCUSSION ON CONTROL UNIT	11
2.2 FIBRE OPTIC CABLES	12
2.3 SETUP FUNCTIONS	12
3. CALIBRATION & FLUID PREPARATION METHODS	14
3.1 PROCEDURE OF ZERO FLUID PREPARATION METHOD	14
3.2 SPAN FLUID PREPARATION METHOD#1	15
3.3 SPAN FLUID PREPARATION METHOD#2	16
3.4 CALIBRATION METHODS	20
3.4.1 5-POINT LINEARIZATION & CALIBRATION PROCEDURE	20
3.4.2 3-POINT LINEARIZATION & CALIBRATION PROCEDURE	24
4. MAINTENANCE	27
4.1 DO'S	27
4.2 DON'T'S	27
5. TROUBLESHOOTING	28
5.1 PX2 Module Color Code	28
5.2 How to Test UV Source Lamp & Optical Probe?	29
A.1 SPARE PARTS LISTING	31
A.2 REFERENCE DRAWINGS	31

ADDITIONAL SAFETY INFORMATION



The analyzer is housed in an explosion proof housing and is designed for use in a Class 1, Division 1, Group B, C, D environment. It is the customer's responsibility to ensure safety especially when flammable liquids are being analyzed since the potential of leaks always exist.

The customer should ensure that the principles of operating of this equipment are well understood by the user. Misuse of this product in any manner, tampering with its components, or unauthorized substitution of any component may adversely affect the safety of this instrument.

Since the use of this instrument is beyond the control of Teledyne, no responsibility by Teledyne, its affiliates, and agents for damage or injury from misuse or neglect of this equipment is implied or assumed.

ATEX Certified Product

If this unit is ATEX certified, no modifications are permitted without reference to Intertek.

Unpacking the Instrument

Your Teledyne Analytical Instruments instrument has been carefully packaged to protect it from damage during shipment and dry storage. Upon receipt please follow the procedure outlined below.

1. Before unpacking, inspect the condition of the shipping container to verify proper handling by the carrier. If damage is noted, save the shipping container as proof of mishandling for the carrier.
2. Check the contents of the shipping container with the items and quantities shown on the packing list. Immediately report any discrepancies to TAI.
3. Save the original packing material until you are satisfied with the contents. In the event the product(s) must be returned to TAI, the packing material will allow you to properly ship it to TAI.
4. Familiarize yourself with the instrument before installation and follow proper installation and wiring procedures.

MODEL 6650SP-XD, UV Fluorescence, OIW Analyzer

1. Theory of Operation

1.1 Introduction of Fluorescence Background

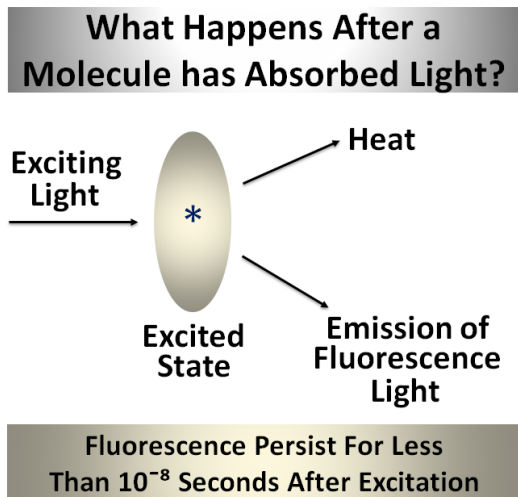

Figure 1-1: Fluorescence Theory

Fluorescence is the emission of light from any substance and occurs from electronically excited states.

Fluorescence occurs when a molecule absorbs light energy at one wavelength and re-emits light energy at another, typically longer, wavelength. The wavelength where maximum absorption occurs is called the excitation wavelength, and the wavelength where maximum emission occurs is called the emission wavelength. The emitted light is proportional to the concentration of the analyte being measured.

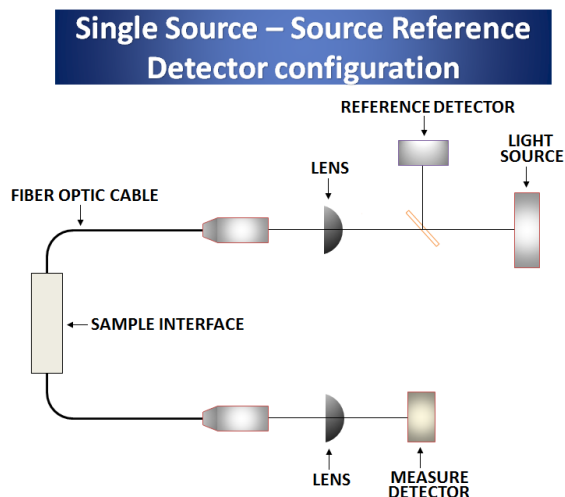

Figure 1-2: Operating Principle of 6650

The light source launches excitation light through the excitation wavelength selection filter and then into a fiber optic cable. The fiber optic cable transfers the excitation light

to fluorescence probe mounted in the process. The fluorescence probe launches light into the process sample and collects the molecular fluorescence (emission) from the sample. The emission light is then transferred from the probe through fiber optic cable to the analyzer. The emission light passes through an emission filter in order to remove any residual excitation energy collected by the fluorescence probe. The emission light then impinges a detector and the fluorescence intensity is displayed on the analyzer. The local display converts the output from Photo Transmitter into PPM and provides the corresponding analog output as per the range.

MODEL 6650SP-XD, UV Fluorescence, OIW Analyzer

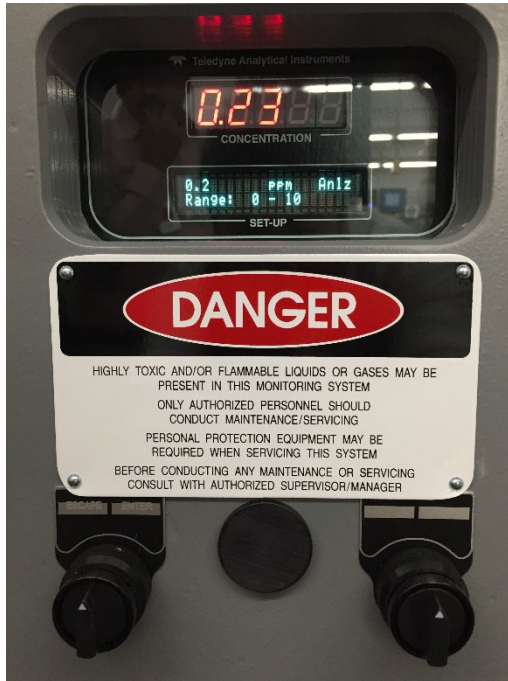

Figure 1-3: Model 6650SP-XD-Control Unit Front Panel

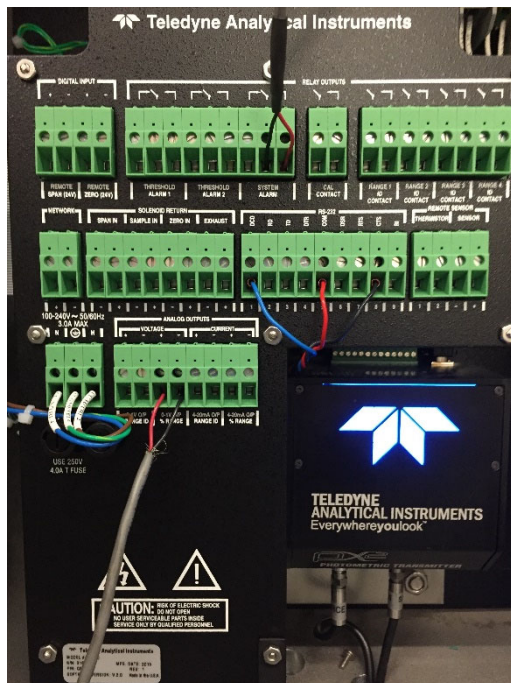

Figure 1-4: 6650SP-XD, Customer Interface & PX2 Location

The Model 6650SP-XD UV Fluorescence Analyzer is a sophisticated instrument designed to measure an oil concentration in water. It consists of a Control Unit, PX2 Photometric Transmitter, and an integrated Fluorescence Probe. The Analyzer is housed in an explosion proof housing with a window providing visual access to the control unit display. Operational controls are conveniently located on the outer door of the enclosure so the unit can be operated without having to open the door.

The PX2 Photometric Transmitter is a dedicated module that includes a flashed xenon UV light source, detectors and filters plus input and output connections for the probe. It communicates with the control unit via a digital RS485 connection. The transmitter is configured at the factory to produce a highly selective, narrow UV band of radiation to optically stimulate a target species (the analyte) in a solution. The excited molecules almost immediately return to a ground state with a corresponding longer wavelength emission whose signature is characteristic of the oil species in solution. The Model 6650SP-XD precisely measures the corresponding fluorescence emission and the control unit converts signal and displays the concentration in units convenient to the end user.

The analyzer is equipped with configurable high and low concentration alarms, a system failure alarm with digital and analog output signals for process control and measurement. An integral probe interfaces

MODEL 6650SP-XD, UV Fluorescence, OIW Analyzer

with the process and transmits optical signals to and from the sample.

1.2 Major Components

Before system power ON & Start-up, ensure the following below components OR accessories are there;

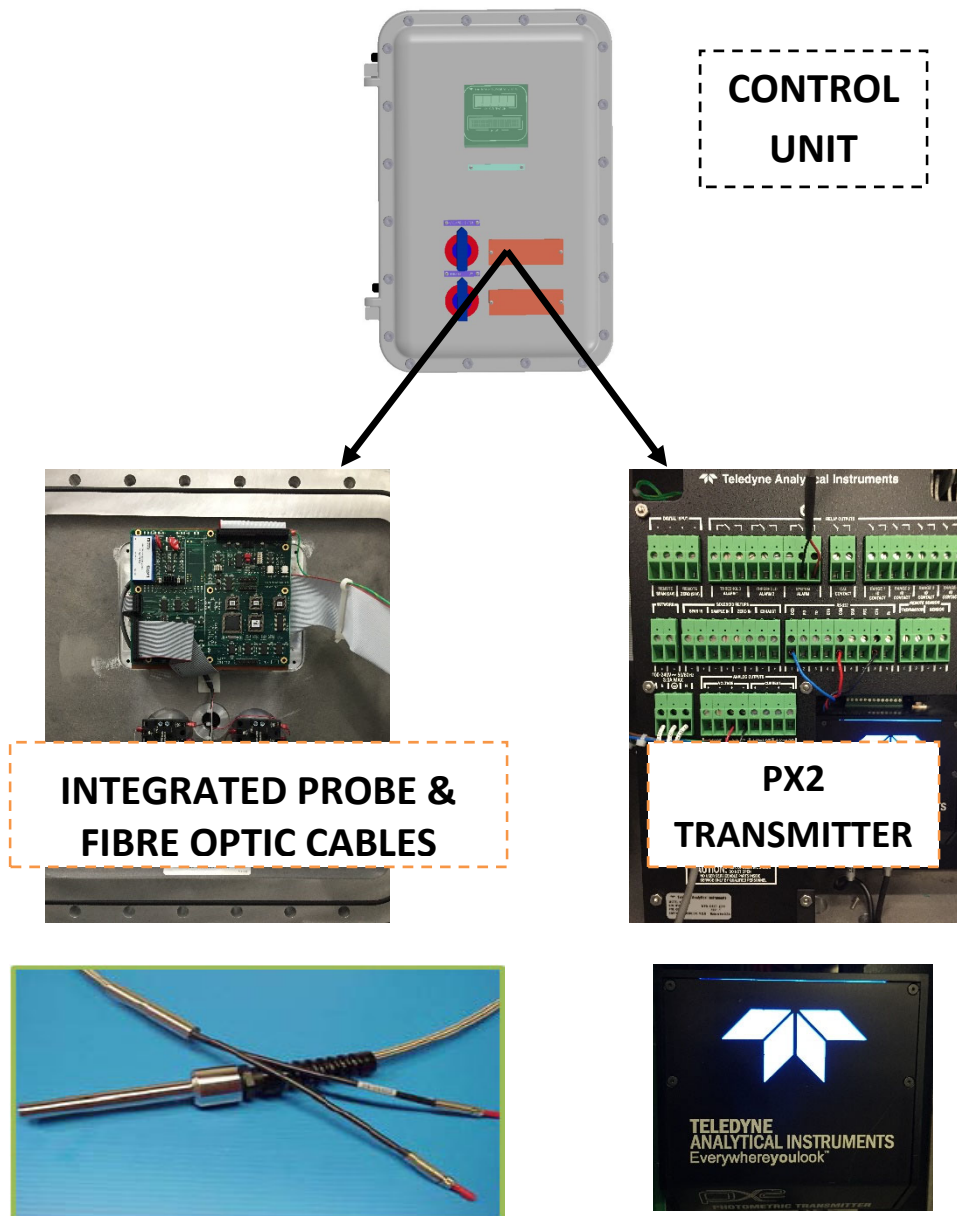

Figure 1-5: 6650SP-XD, Major Components details

MODEL 6650SP-XD, UV Fluorescence, OIW Analyzer

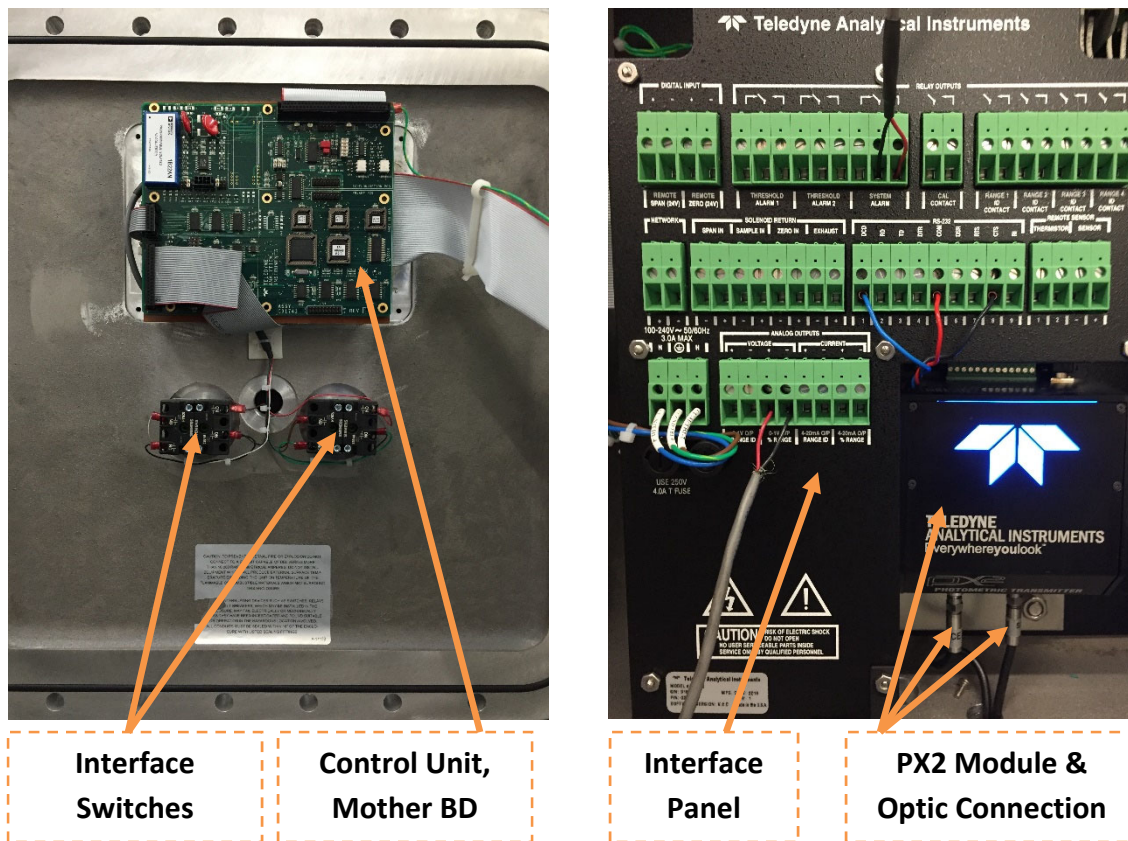

Figure 1-6: 6650SP-XD, Control Unit details & PX2 Location

A typical Model 6650SP is shown in Figure 1-6. The Model 6650SP Analyzer depicted is a bulkhead mounting instrument designed to measure a specific component of interest in a solution. The Model 6650SP is a highly configurable system and is often modified for an application. Any non-standard modifications to the instrument that affect the operation, specifications, maintenance, replacement parts listing etc. are described in an addendum. Check the front of this manual for any addendum that may pertain to your instrument.

The PX2 Transmitter is the heart of the Model 6650SP-XD. It houses the measurement and reference detectors, filters, UV light source and associated electronics for data collection and signal pre-processing from the incoming radiation from the sample probe. The collected data is averaged and passed to the control unit for signal processing and display through the RS-485 port.

The PX2 Transmitter is carefully configured and tested at the factory for your specific application. The unit can be reconfigured if necessary via a USB connection with a remote computer. Contact the factory for further information on reconfiguring or making changes to the PX2 setup.

A self-testing routine is installed in the module with multi colored LEDs indicating status: in test, unit ok, or a fault condition. The indicators will light up and cycle through a series of colors (blue, red, green, purple, light green, aqua, and blue) as the unit is supplied with power. Once the LED has returned to solid blue, the unit is ready for operation. The transmitter operates from a dedicated 24VDC power supply mounted adjacent to the transmitter.

2. CONTROL UNIT & SETUP FUNCTIONS

MODEL 6650SP-XD, UV Fluorescence, OIW Analyzer

2.1 BRIEF DISCUSSION ON CONTROL UNIT

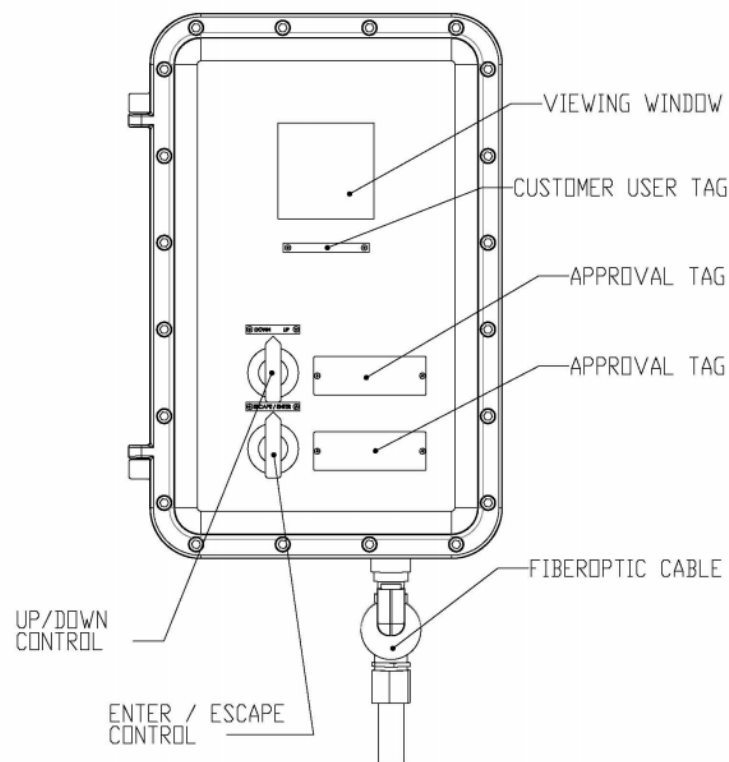

Figure 2-1: 6650SP-XD, Control Unit Front Panel

In addition to acting as the main user interface, the Model 6650SP-XD Control Unit is responsible for signal conditioning, display output, alarm handling, output signal generation, and instrument calibration.

The PX2 Transmitter outputs the fluorescence level as a raw signal which is the average of many readings per second and outputs it to the controller via the RS-485 port. The control unit takes the raw count signal from the Transmitter, conditions and linearizes it, then displays the output in meaningful engineering units such as ppm. It also provides user functions such as alarm configuration, and calibration control. Figure 2-1 shows the front panel interface of the Model 6650 Control Unit. The unit is mounted on the front door of the system enclosure.

MODEL 6650SP-XD, UV Fluorescence, OIW Analyzer

2.2 FIBRE OPTIC CABLES

Typically, the probe and fiber optic cables are shipped as separate items and must be installed before using the analyzer. The probe is shipped as a complete assembly with a bifurcated fiber optic cable attached.

To install the optical cable:

1. Thread the bifurcated fiber optic cable through the 1-3/4" fitting on the bottom of the enclosure.
2. Insert the optic cables into the sockets at the bottom of the transmitter. Both the cable end connectors and sockets are labeled. Make sure the connectors are inserted into the correct socket. See Figure 3-7.

Hand-tighten the liquid-tight connector's 1 3/4" nut at the bottom of the NEMA-4 housing. The probe is fabricated with a 1/2" dia. tube (13 mm) for interfacing with the process fluid using

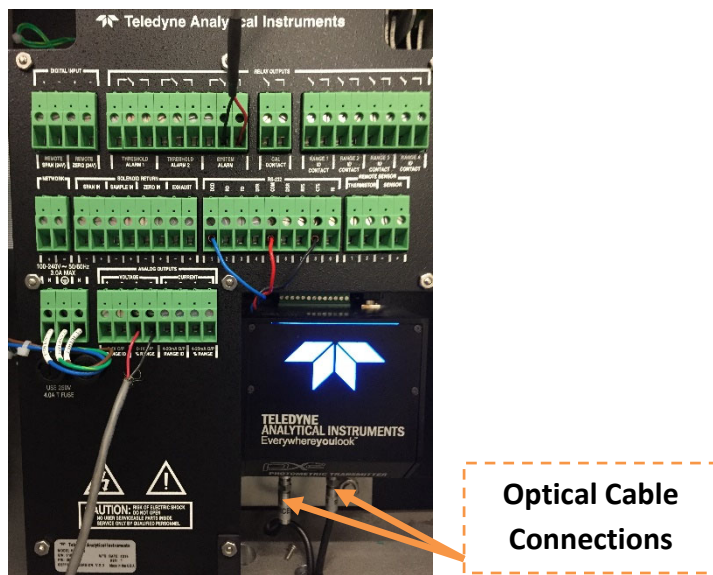

a standard slip-fit tube fitting.

It is important that all oil in the process fluid over 20 mg/l be totally representative of the process and homogenized as an emulsion. The oil should be uniformly dispersed otherwise erroneous readings can occur. An optional ultrasonic homogenizer can be installed in the analyzer to create a uniform dispersion of oil in water.

2.3 SETUP FUNCTIONS

The operator interacts with the analyzer primarily through the two switches mounted on the front door of the explosion proof housing.

ESCAPE/ENTER SWITCH (Data Entry): The ESCAPE/ENTER switch is used to input data, from the alphanumeric VFD setup screen into the instrument:

UP/DOWN SWITCH: The UP/DOWN switch is used to select the function to be performed. Choose UP or DOWN to scroll through the setup functions:

MODEL 6650SP-XD, UV Fluorescence, OIW Analyzer

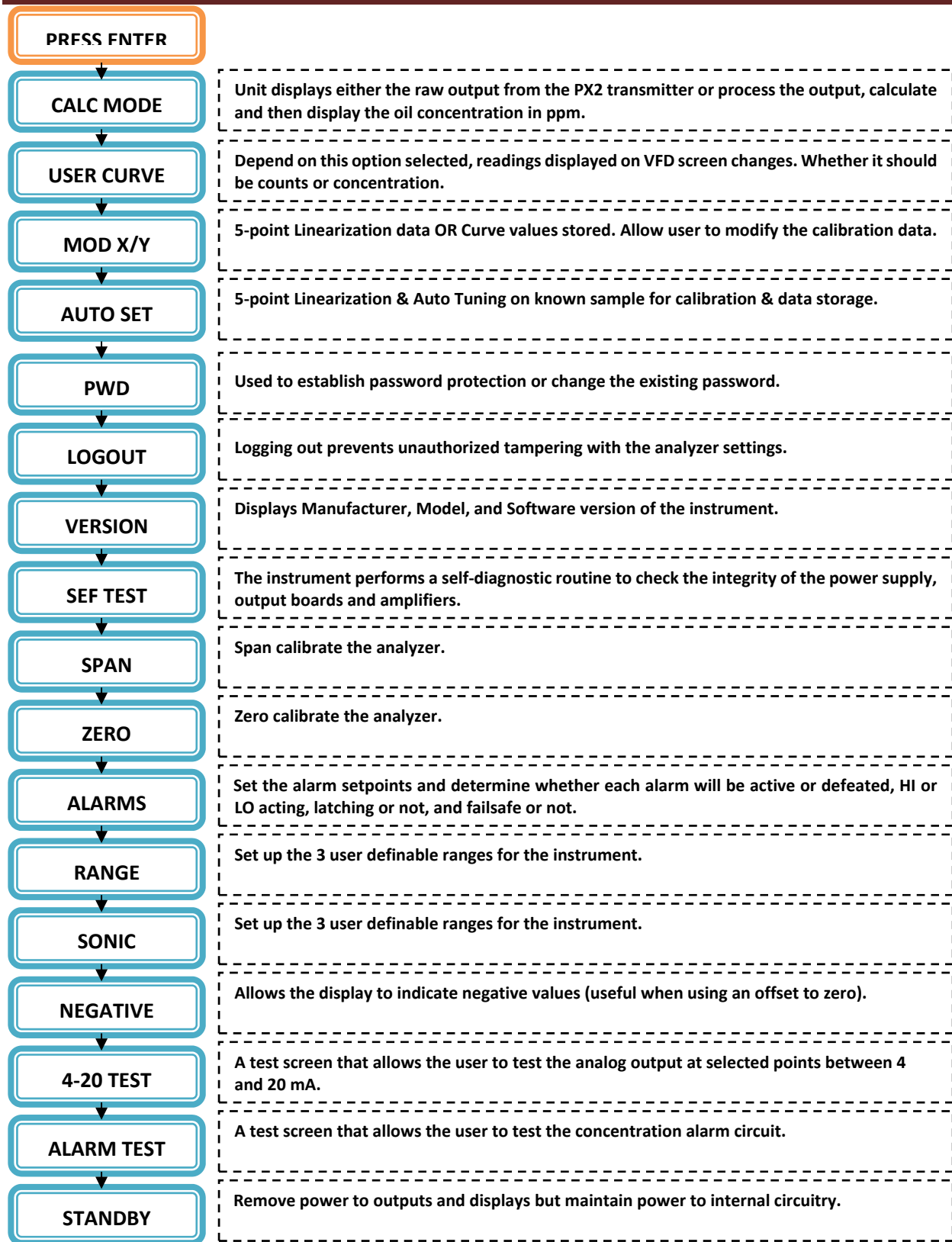

3. CALIBRATION & FLUID PREPARATION METHODS

MODEL 6650SP-XD, UV Fluorescence, OIW Analyzer

3.1 PROCEDURE OF ZERO FLUID PREPARATION METHOD

Zero calibration can be performed two ways;

- a. Method#1: When sensor installed in Brown Empty Calibration Bottle (ideal zero condition for sensor).
- b. Method#2: When sensor is installed in zero fluid prepared from process sample using Teledyne CAL Kit (which will compensate process background interference, if any).

Procedure of Zero Fluid Preparation Methods#2

- a) Collect one gallon of sample water from system either from Safe Vent OR Sample Return.
- b) Filter one liter of collected water to remove non-dissolved oil like Below. Keep funnel on beaker & spread the filter paper properly & put it on funnel. Pour the sample fluid on filter paper, make two beakers of zero fluid.
- c) Sparge for 10 minutes with oil-free air to remove dissolved oil.
- d) Divided the solution into two 500ml portion and set aside for later use.

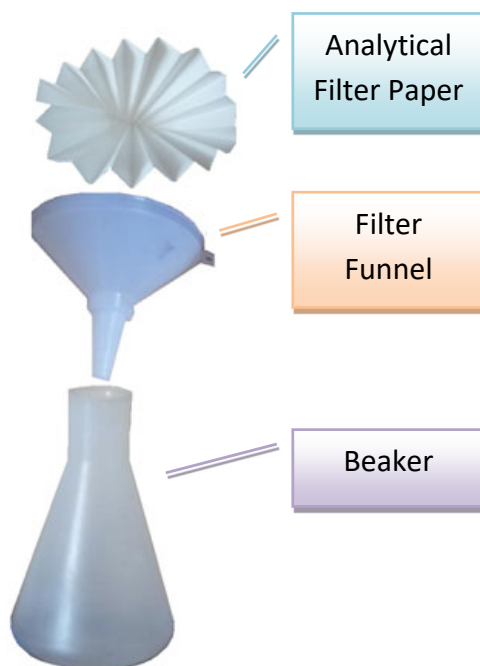

MODEL 6650SP-XD, UV Fluorescence, OIW Analyzer

3.2 SPAN FLUID PREPARATION METHOD#1

- a. Method#1: Quinine Sulfate with 18 M Sulfuric Acid

The original chemicals we need to make 1 PPM of required sample (total of 500 ml):

- a) 18 M Sulfuric Acid (liquid, CAS 7664-93-9).
b) Quinine Sulfate (powder, CAS 22640)
c) Start with solvent: we need to make 500ml of 0.1 M Sulfuric Acid. To do this we have to add 2.78 ml of 18 M Sulfuric Acid to 497.22 ml of Water. See the calculations below:

$$18M (\text{Sulfuric Acid}) * X = 0.1 M (\text{Sulfuric Acid}) * 500 \text{ ml (Total Volume)}$$

$$X = 2.78 \text{ ml}$$

- d) Then continue with measuring required amount of Quinine Sulfate: To do this we have to add 0.0005 g of Quinine Sulfate to 500 ml of 0.1 M Sulfuric Acid (we did already). See the calculations below:

$$0.0005 \text{ g} = \frac{1 \text{ PPM Quinine Sulfate}}{1\,000\,000} * 500\text{ml } 0.1 \text{ M Sulfuric Acid}$$

If you cannot get 0.0005 g (your weight does not go so low) you can all the time double your total volume:

- e) Add 5.56 ml of 18 M Sulfuric Acid to 994.44 ml of Water.
f) add 0.001 g of Quinine Sulfate to 1000 ml of 0.1 M Sulfuric Acid

It is advisable to store this in Brown bottles [not to allow light passing thro' the bottles].

MODEL 6650SP-XD, UV Fluorescence, OIW Analyzer

3.3 SPAN FLUID PREPARATION METHOD#2

Using a representative specimen oil sample from process (Customer provided) with Teledyne CAL Kit.

STEP#1: Pour 500 mL of zero fluid into the blender's container



STEP#2: Calculate the number of micro liters of Oil that will be required to produce a span fluid of full scale concentration when mixed with 500mL of zero fluid in the blender.

$$\text{Micro liters Oil} = \text{PPM Concentration}/2$$

Depend on Range of the analyzer; micro syringe should be used for preparation of span fluid.

MODEL 6650SP-XD, UV Fluorescence, OIW Analyzer

For 0-200PPM Range



For 0-20PPM Range



STEP#3: Obtain a sample specimen of Oil. It is important that this specimen be the same oil as is to be measured during sampling because individual oils may have very different instrumental responses towards UV lights.

If analyzer Range is 0-20PPM then use proper Micro syringe. Set the micro syringe as per Step#2 calculation for required span fluid concentration.

NOTE: Before Operating the Micro Syringe for desired volume, Un-lock the plunger assembly by keeping the switch at Un-lock position. Once desired Volume is set on window, lock the switch by keeping at lock position.

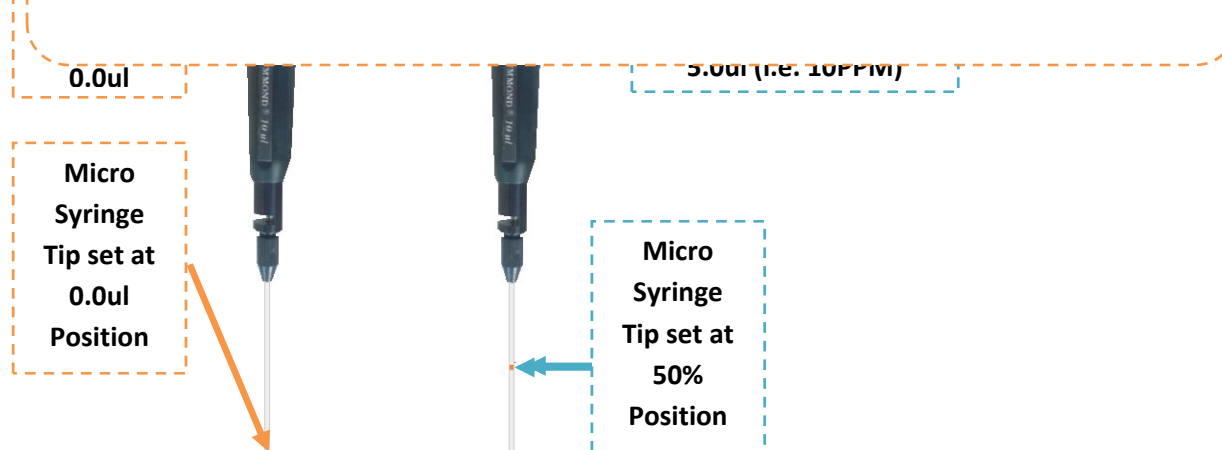

MODEL 6650SP-XD, UV Fluorescence, OIW Analyzer

STEP#4: Before injecting oil into blender container, follow some tips to clean the residue of oil from the tip and outer body of the needle once the correct volume has drawn into the micro syringe.

Press & Hold the plunger assembly inside the Oil sample container. Release the plunger assembly slowly, so that uniform oil will be pulled inside the syringe walls. Once you observe that there is no air bubble, means oil pulled is proper

Once desired oil is pulled, make sure that plunger assembly should not be operated at any case. Ensure that plunger assembly is locked properly (Lock/Un-lock SW should be at Lock Position).



Specimen Oil sample Container



Carefully wipe off the residue oil with tissue paper from the outer body of the needle.

When wiping the syringe tip. Be careful not to suck oil from the inside of the needle

MODEL 6650SP-XD, UV Fluorescence, OIW Analyzer

STEP#5: Injection of desired oil. Run the blender with container Lid removed at the highest attainable speed without spillage. Follow the below procedure step by step for oil injection.



- 1) Run the blender with container Lid removed at the highest attainable speed with speed without spillage.
- 2) Inject the contents of the syringe oil into the water midway between the center of the vortex and the wall of the blender container. Make sure oil injection happens under water; otherwise part of the oil will be thrown against the wall of the blender container

NOTE: while injecting oil as per above step#2, make sure that when you press plunger assembly to release the oil inside water, do not release the plunger assembly when it is inside water while removing the syringe. Once oil injection is completed, take out the syringe from water & carefully wipe off the residue of water from the tip & outer body of the needle.

- 3) Put the lid on the blender container, bring the blender up to maximum speed and homogenize the contents for exactly 2 minutes.
- 4) As soon as the span fluid is prepared consume the span fluid within 5 to 10 mins.

3.4 CALIBRATION METHODS

MODEL 6650SP-XD, UV Fluorescence, OIW Analyzer

3.4.1 5-POINT LINEARIZATION & CALIBRATION PROCEDURE

5-point Linearization/Calibration Procedure is performed using Auto Set feature in setup functions.

Please note, oil to oil, Fluorescence signal strength changes. Oil in water application is not a linear application. Only performing 0% and 100% fluid calibration can provide good data when measured zero and span fluid but it won't be linear throughout the range. Therefore, linearization with multiple oil concentration is utmost important for oil in water applications to get best results throughout the range being selected.

Performing 5-point fluid calibration, keep the oil in water sample as below. For example, range is set as 0-100ppm then below oil in water sample shall be kept ready for this procedure;

- 100% Sample (100ppm) OR Sample (1st Sample)
- 75% Sample (75ppm) OR Sample 1(2nd Sample)
- 50% Sample (50ppm) OR Sample 2 (3rd Sample)
- 25% Sample (25ppm) OR Sample 3 (4th Sample)
- 0% Sample (0ppm) OR Sample 4 (5th Sample)

Follow the below procedure to carry out 5-point linearization/Calibration;

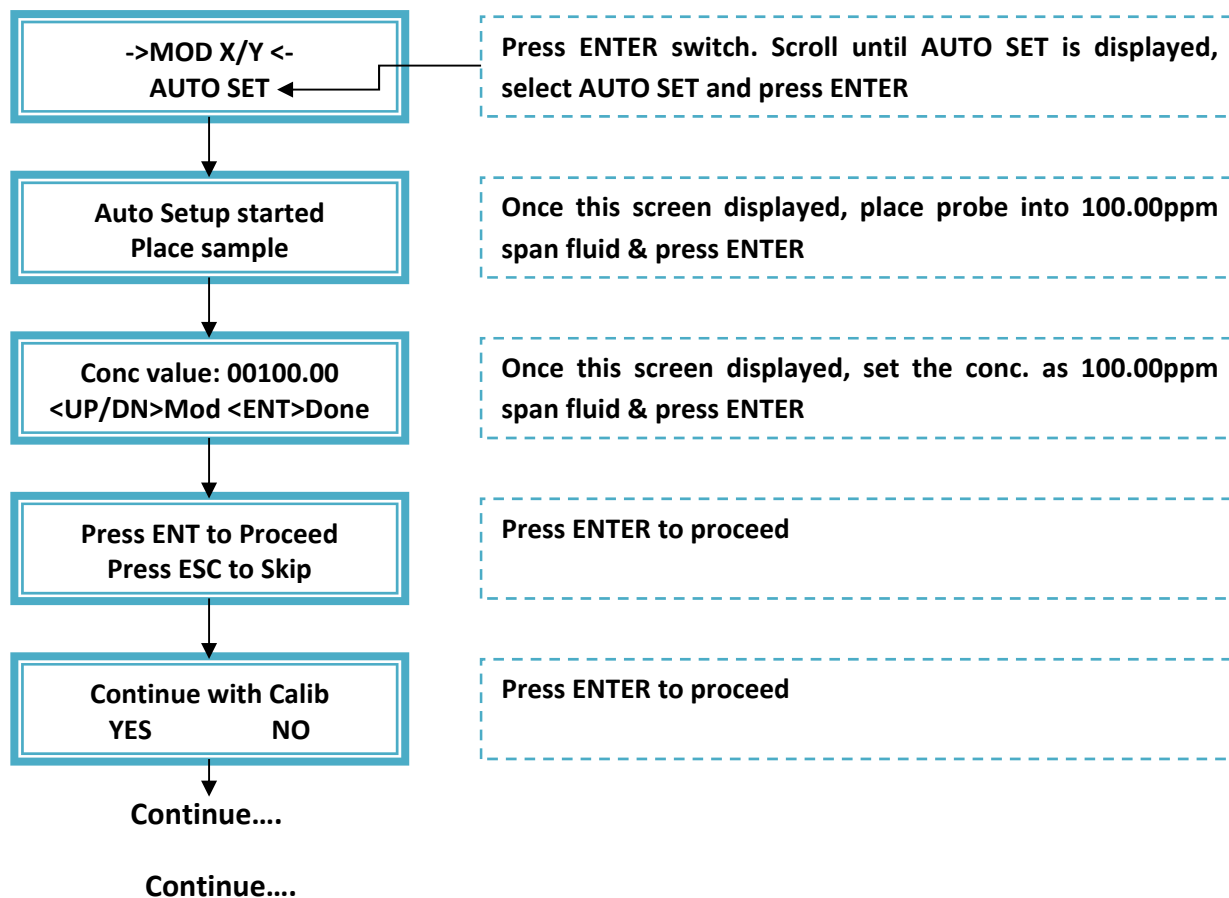

MODEL 6650SP-XD, UV Fluorescence, OIW Analyzer

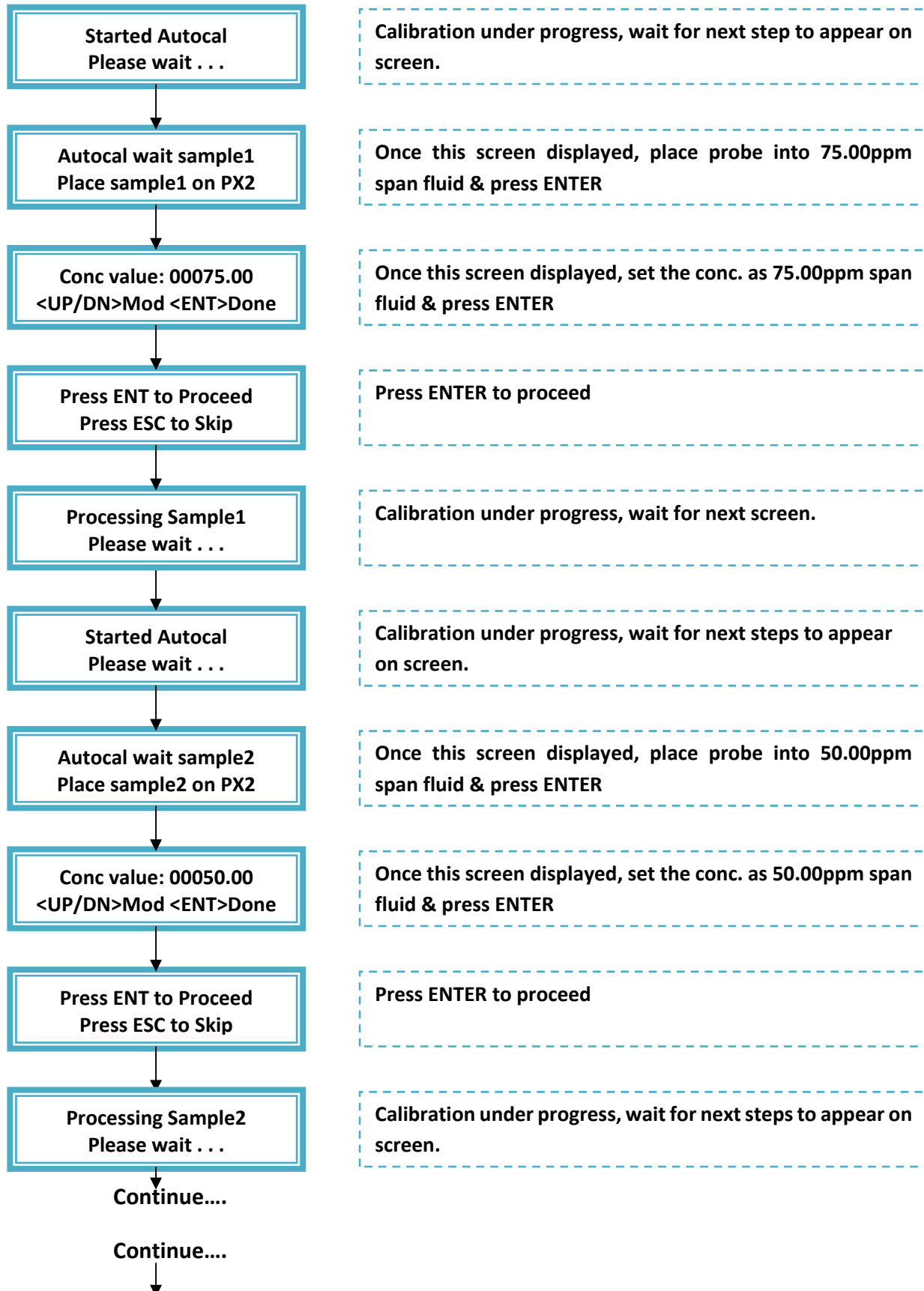

MODEL 6650SP-XD, UV Fluorescence, OIW Analyzer

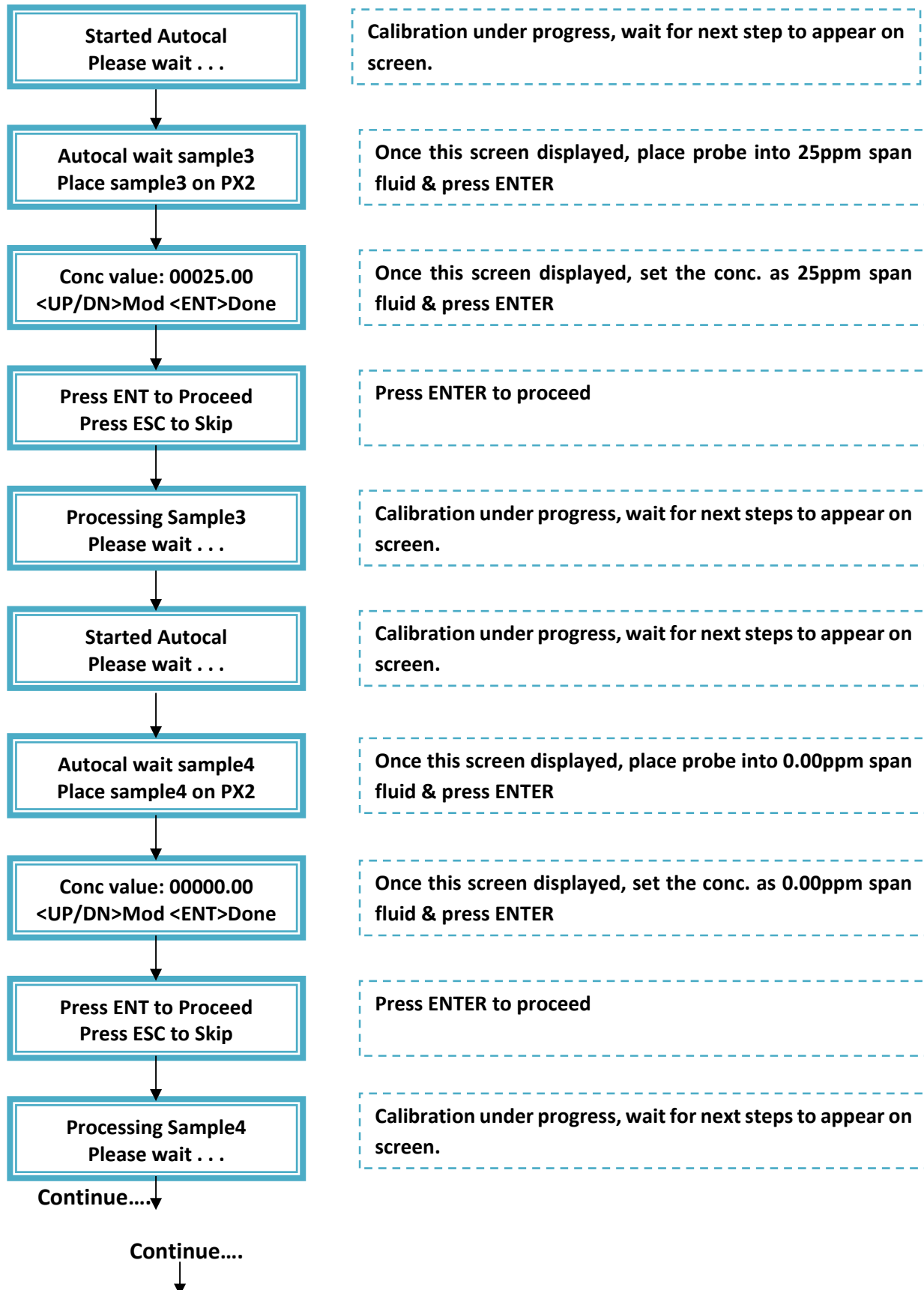

MODEL 6650SP-XD, UV Fluorescence, OIW Analyzer

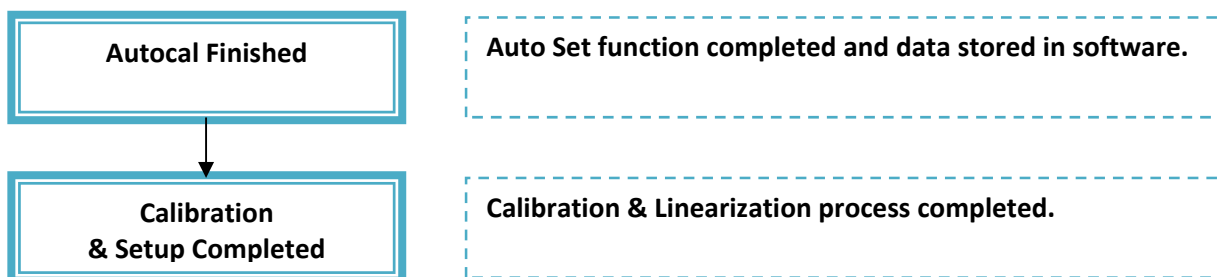

NOTE: After 5-Point Auto Set completion, verify the Calibration & Linearization data through MOD X/Y parameter in setup.

Follow the below procedure to verify the calibration & Linearization data;

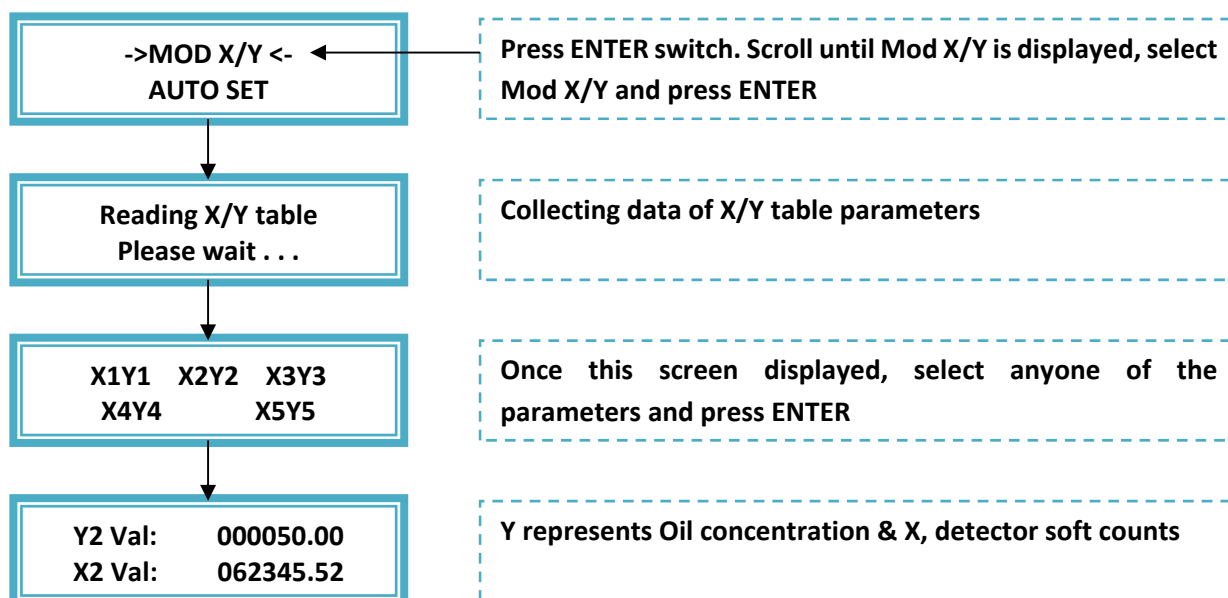

3.4.2 3-POINT LINEARIZATION & CALIBRATION PROCEDURE

MODEL 6650SP-XD, UV Fluorescence, OIW Analyzer

Sometimes, in case 5-Point Auto Setup cannot be performed then it is recommended to perform 3-point Auto setup to get better results. To perform 3-Point fluid calibration, keep the oil in water sample as below. For example, range is set as 0-100ppm then below oil in water sample shall be kept ready for this procedure;

- 100% Sample (100ppm) OR Sample (1st Sample)
- 50% Sample (50ppm) OR Sample 1 (2nd Sample)
- 0% Sample (0ppm) OR Sample 2 (3rd Sample)
- 0% Sample (0ppm) OR Sample 3 (4th Sample)
- 0% Sample (0ppm) OR Sample 4 (5th Sample)

Follow the below procedure to carry out 5-point linearization/Calibration;

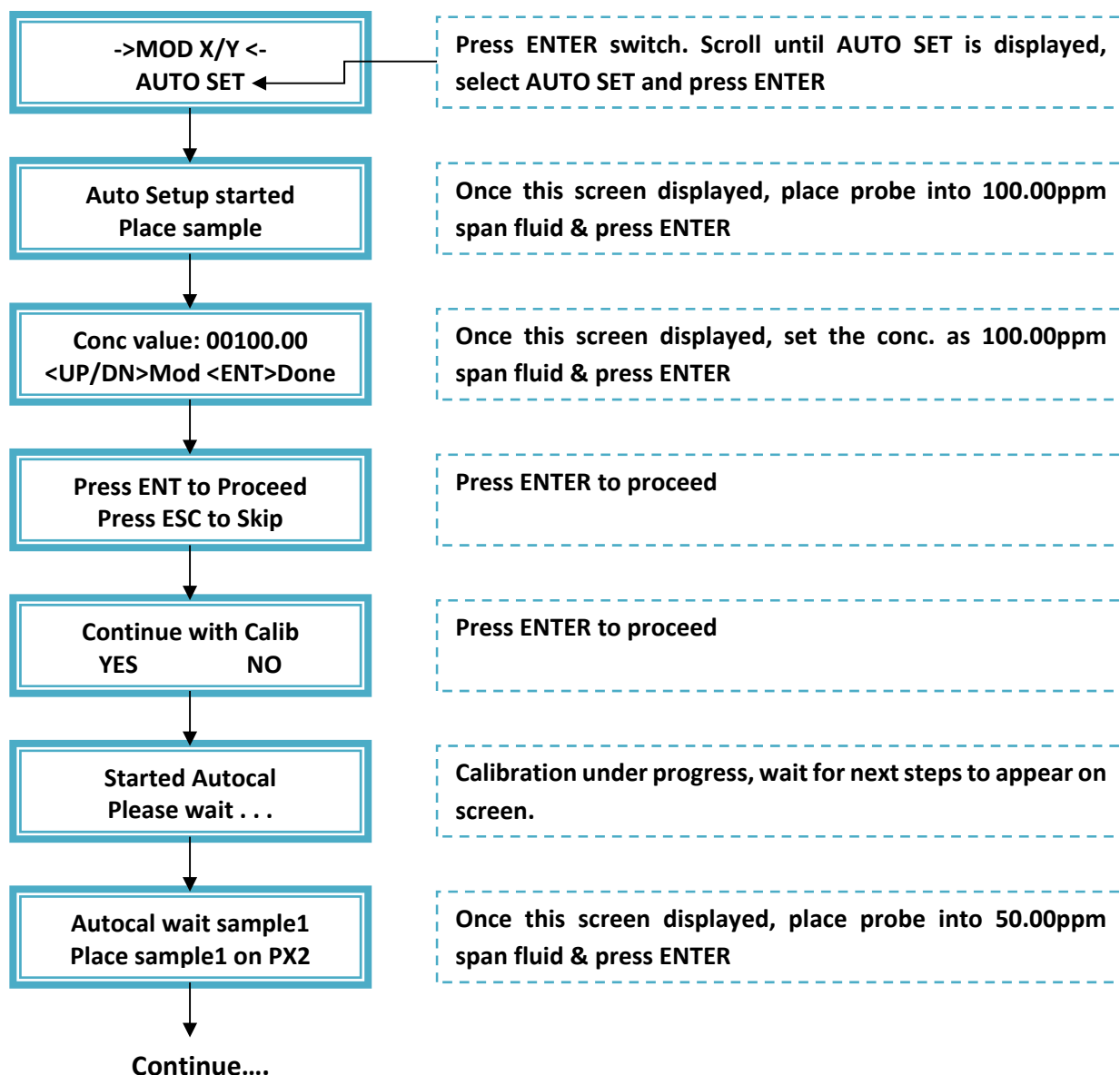

MODEL 6650SP-XD, UV Fluorescence, OIW Analyzer

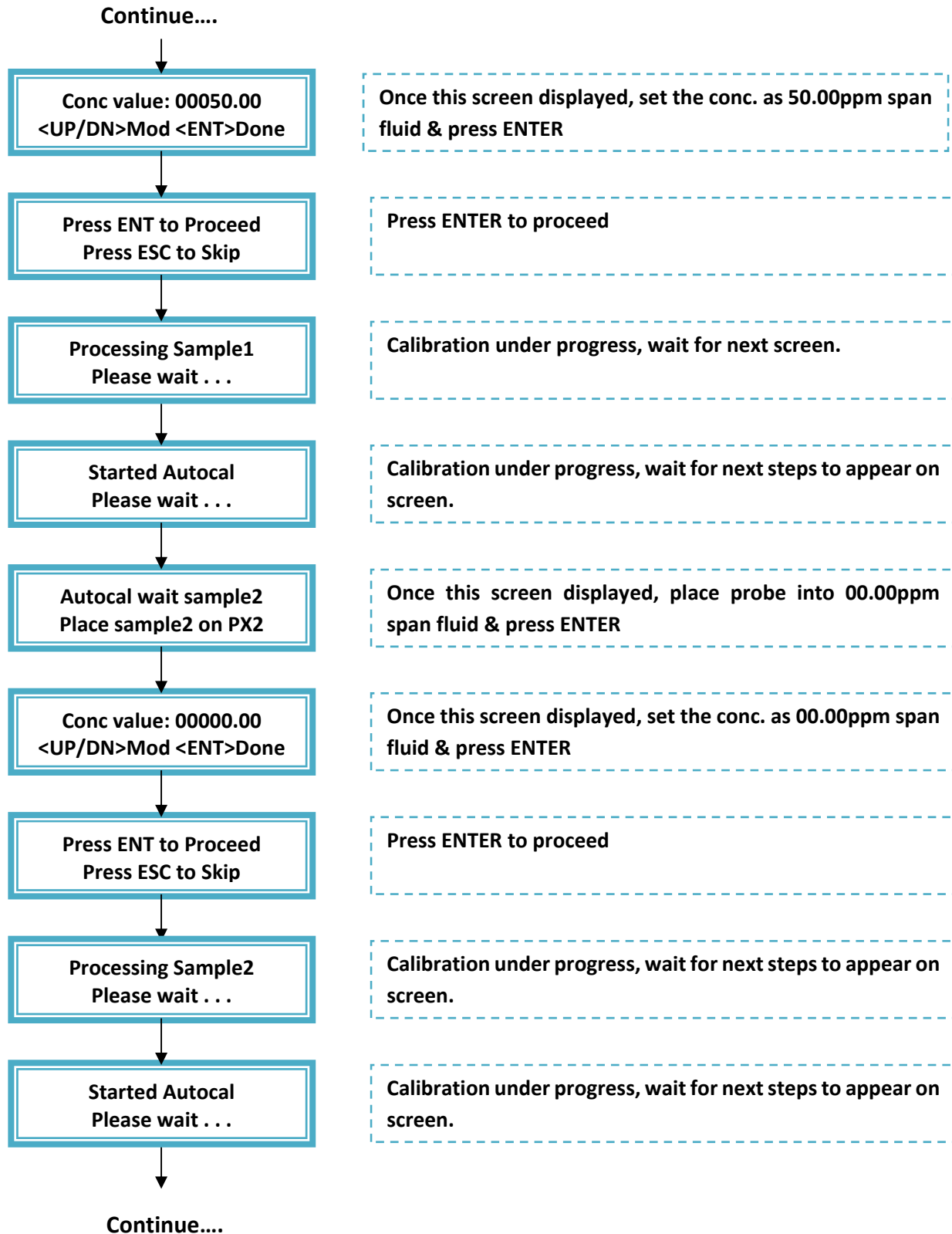

MODEL 6650SP-XD, UV Fluorescence, OIW Analyzer

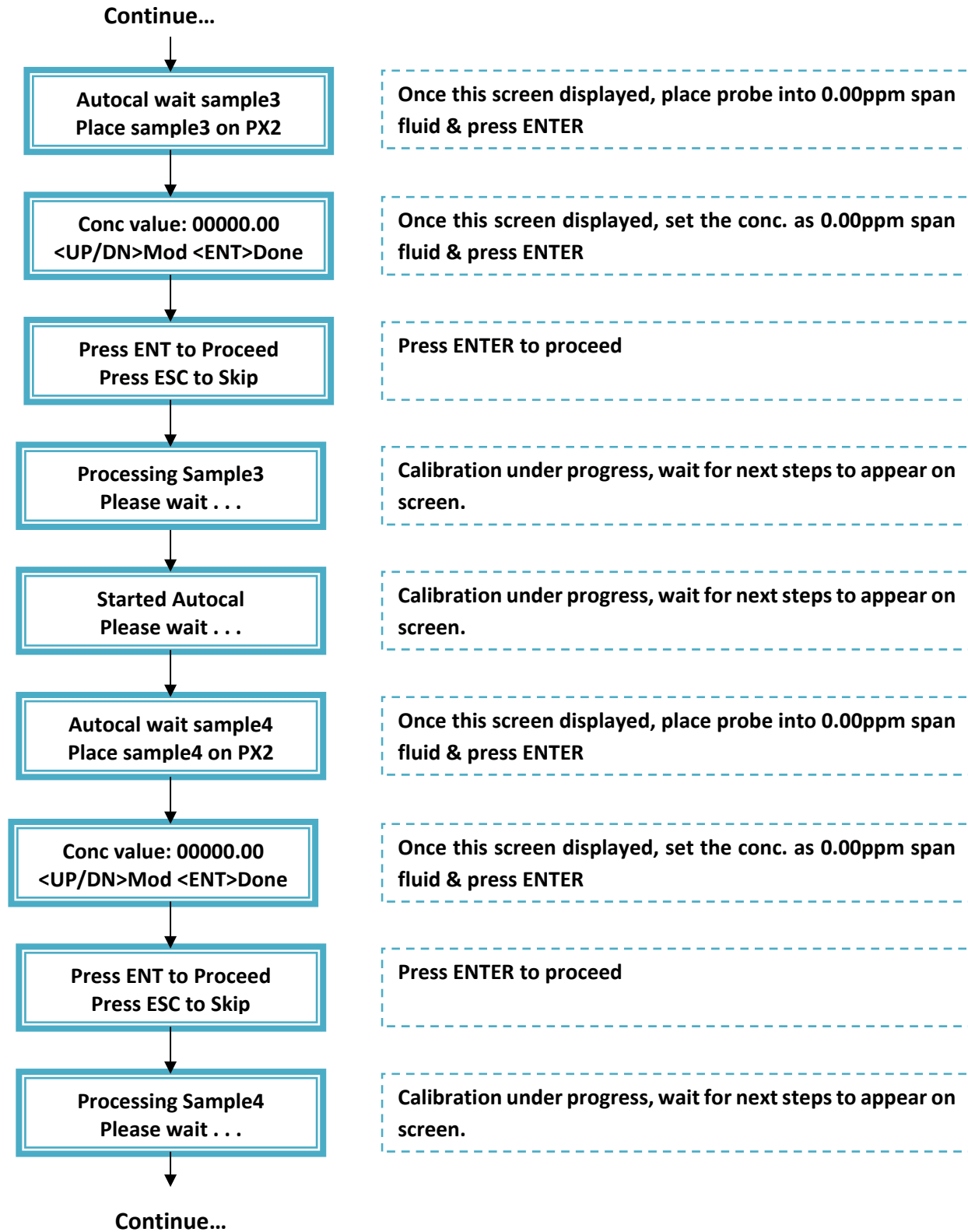

MODEL 6650SP-XD, UV Fluorescence, OIW Analyzer

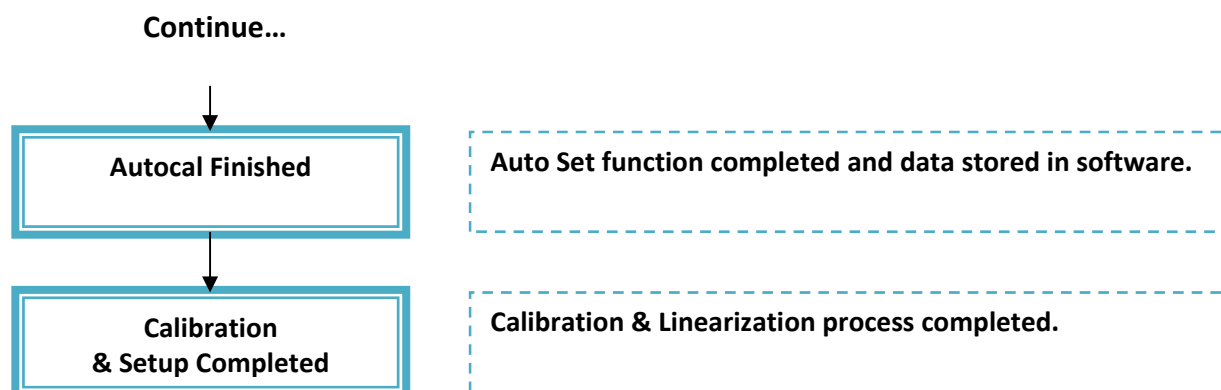

NOTE: After 3-Point Auto Set completion, verify the calibration & Linearization data through MOD X/Y parameter in setup. Please note, X3Y3, X4Y4 & X5Y5 detector soft count data should be same, as these concentration values are set as 00.00ppm. If they are same, fine. If not, calibration data is not correctly stored and need to perform the Auto Setup again.

4. Maintenance

The system operates continuously without adjustment. Under normal conditions, only routine maintenance procedures are necessary. When routine maintenance is carried out, it must be performed on both sampling system & 6650SP-XD unit depend on application. The below points are very important while doing maintenance on 6650SP-XD unit.

4.1 DO's

- Monitor the Front Panel Soft Counts on regular basis.
- If process sample is sticky & dirty, then make a routine maintenance to clean the sensor probe tip on regular basis.
- Perform always calibration Check with valid span fluid (0%, 50% & 100% of analyzer range). If readings are within specification, no need for calibration. If not, perform Auto Setup Calibration OR Modify Y parameters through Mod X/Y option to read correctly the solution.
- Make sure that process sample temp. is within the limits of sensor temp. specification.

4.2 DON'T

- Do not fold the Fiber cable less than 8" in radius (The allowed bend radius for fibers supplied with system is eight 8 inches).
- Do not expose the sensor to ambient light for longer durations.
- All units supplied by TAI have been configured for specific applications. This instrument cannot be used as is for a different application without first establishing a relationship between the new sample and the fluorescence response from the instrument. TAI will be not responsible for nonfunctional OR bad results from supplied system.

5. Troubleshooting

MODEL 6650SP-XD, UV Fluorescence, OIW Analyzer

5.1 PX2 Module Color Code

Problem	Cause	Solution
PX2 Module Turned Red OR Flashing Red	Stray Light Leak	If there has been a major change in the probe installation or process piping, very likely, there will be a stray light leak into the system. Verify that the monitoring location is in complete darkness. If both the reference detector and measure detector are not exposed to a light signal a Broken Light Path message will appear on the VFD display and the LEDs that make up the Teledyne logo on the transmitter will turn from blue to red.
	Light Source Failed	when the measurement detector sees a low signal while the reference detector signal is normal. This will cause a Light Source Failed message to occur onscreen and the LEDs on the PX2 to flash red. When this occurs, the display will not report concentration or allow passage to any other function until the light path is restored and functioning correctly
	Optical Probe	Do not leave the probe tip open to atmosphere, it will lead to saturation and damage of optical probe assembly

5.2 How to Test UV Source Lamp & Optical Probe?

MODEL 6650SP-XD, UV Fluorescence, OIW Analyzer



WARNING: Do not stare at the UV light or source with the naked eye to avoid eye injury. Use safety eyewear for UV protection.



Disconnect the Probe cable which is connected at SOURCE. Put a white paper below this SOURCE point and observe whether the UV light (blue spot) is appearing on white paper every 2 seconds On & OFF. If yes, then UV Light is fine. If not then either UV light source or UV light Filter assembly having some issue.

MODEL 6650SP-XD, UV Fluorescence, OIW Analyzer

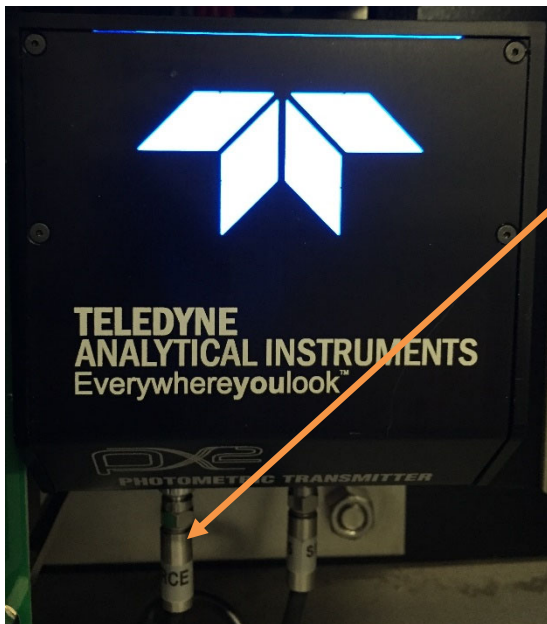

Step#1: To check Optical Probe, ensure UV Source Lamp is working fine as above procedure. When optical probe is connected as per shown picture. UV Light at Probe Tip should be as shown below.

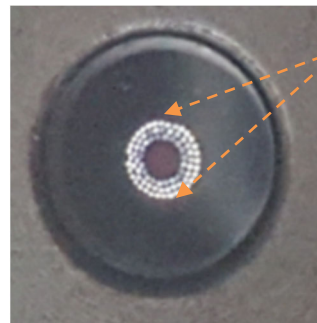

Light shall be visible from many small holes on probe Tip, when Optical probe Source Leg is fine.

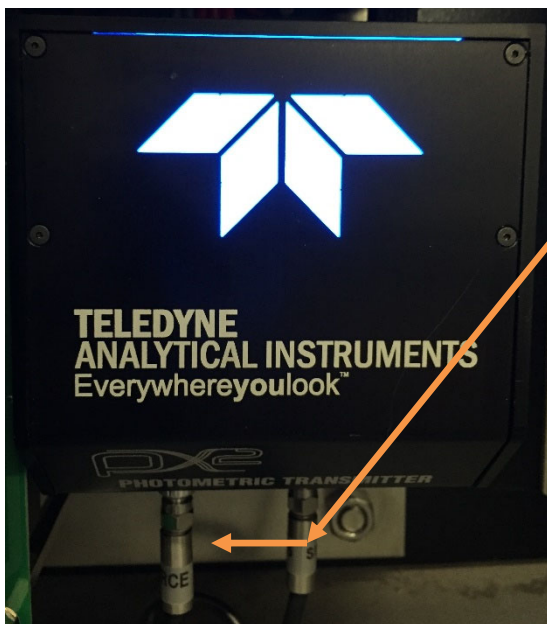

Step#2: Disconnect the Source cable on PX2. Now disconnect the other Optical cable which is connected at Detector and connect this at SOURCE point. When optical probe is connected like that. UV Light at Probe Tip should be as shown below.

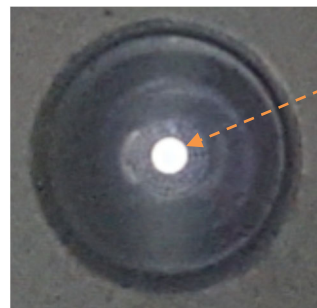

Light shall be visible from one large hole located at centre on probe Tip, when Probe Detector probe Source Leg is fine.

MODEL 6650SP-XD, UV Fluorescence, OIW Analyzer

A.1 Spare Parts Listing

C91743-A Motherboard for RS485

A.2 Reference Drawings

D92638 Outline Diagram CSA Version
D93493 Outline Diagram ATEX Version
C92639 Interconnection Diagram

NOTES: UNLESS OTHERWISE SPECIFIED.

REV	DESCRIPTION	DATE	APP.	REV. BY
0	INITIAL RELEASE	03/30/15	WP	--
1	CHG: PX2 TO RELAY BOARD WIRING	06/29/15	AA	WP
2	CHG PX2 POWER WIRE COLOR	07/30/15	WP	WP
3	SWAP CONNECTIONS WITH PX2 12 & 13	03/30/16	WP	VF

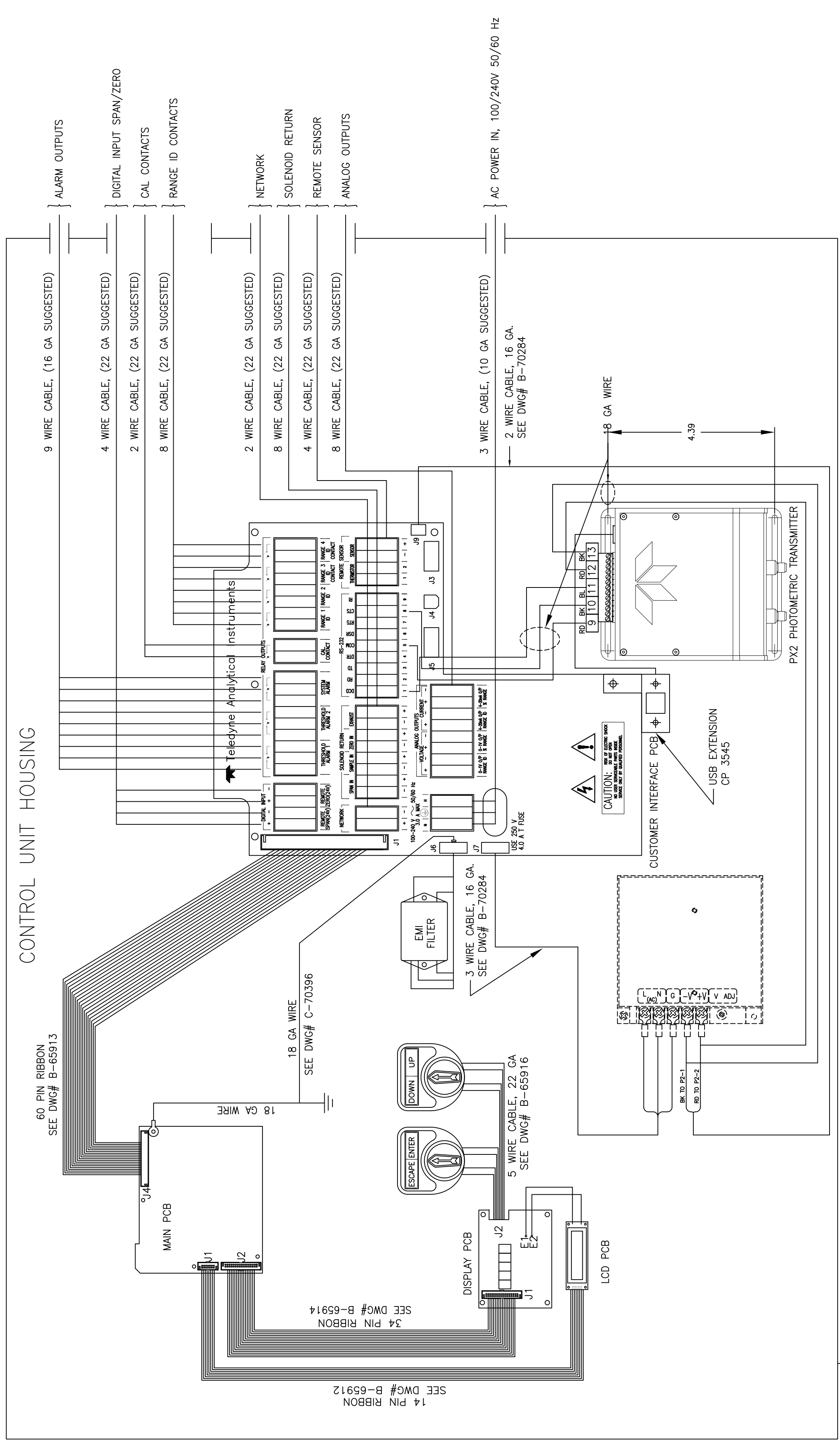

UNLESS OTHERWISE SPECIFIED DIMENSIONS ARE IN INCHES TOLERANCE ANGULAR ±1/2° LINEAR ±.02		THIS DRAWING IS THE PROPERTY OF TELEDYNE ANALYTICAL INSTRUMENTS AND CONTAINS CONFIDENTIAL INFORMATION. IT IS NOT TO BE COPIED, REPRODUCED OR USED WITHOUT WRITTEN PERMISSION.	
TELEDYNE Analytical Instruments A Business Unit of Teledyne Instruments, Inc. City of Industry, California 91748, USA		INTERCONNECTION DIAGRAM OIL IN WATER ANALYZER MODEL 6650SP XD	
SIGNATURES	DATE	TITLE	SCALE
DRFT: W PORTACIO	03/30/15	INTERCONNECTION DIAGRAM OIL IN WATER ANALYZER MODEL 6650SP XD	NONE
CHK:			SIM C69989
APPR:			SHEET 1 OF 1
ENGR: W PORTACIO			REV 3
C.O.: STANDARD			DWG NO. C-92639
REFERENCE CAD ID C92639-3		NOTED	

NOTES: UNLESS OTHERWISE SPECIFIED.

- 1 ALL DIMENSIONS ARE IN INCHES (±.06) AND MILLIMETERS (±1.); INCHES[mm].
- 2 ENCLOSURE: EXPLOSION PROOF HOUSING, KILLARK, UL CLASSIFICATION CLASS I DIVISION I, GRP B, C, D

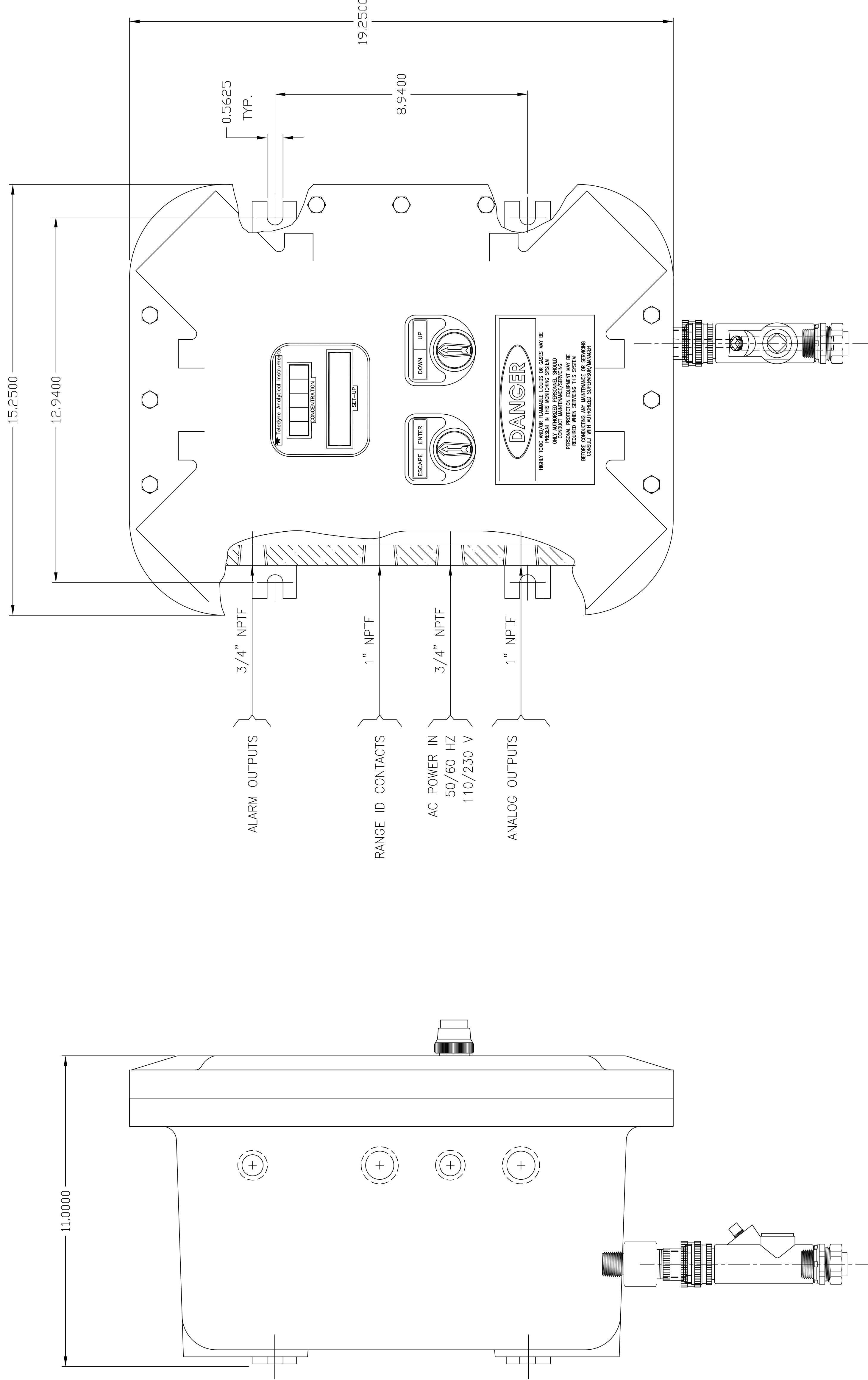

REV.	DESCRIPTION	DATE	APP.	REV. BY
0	INITIAL RELEASE	03/20/15	WP	--
1	ADD: USB PX2 CHG: PRE-AMP BOARD, RS-232	07/30/15	WP	WP

DO NOT SCALE. DWG.		TELEDYNE INSTRUMENTS	
TOLERANCE UNLESS OTHERWISE SPECIFIED: ANGULAR ±1/2°			
LINEAR ±.001, ±.002, ±.005, ±.010			
SIGNATURES		DATE	
DRAFT: W. PORTACIO		03/20/15	
CHK:			
APPR:			
ENGR: W. PORTACIO			
C.O.:			
REFERENCE:	CAD ID: D92638-2		

TELEDYNE INSTRUMENTS		OUTLINE DIAGRAM	
A Analytical Instruments A Teledyne Technologies Company City of Industry, California, 91748, USA			
SCALE		1:2	
SIM		D74606	
SHEET		1 OF 2	
REV.		2	
DWG. NO.		D-92638	
MATERIAL		NONE	

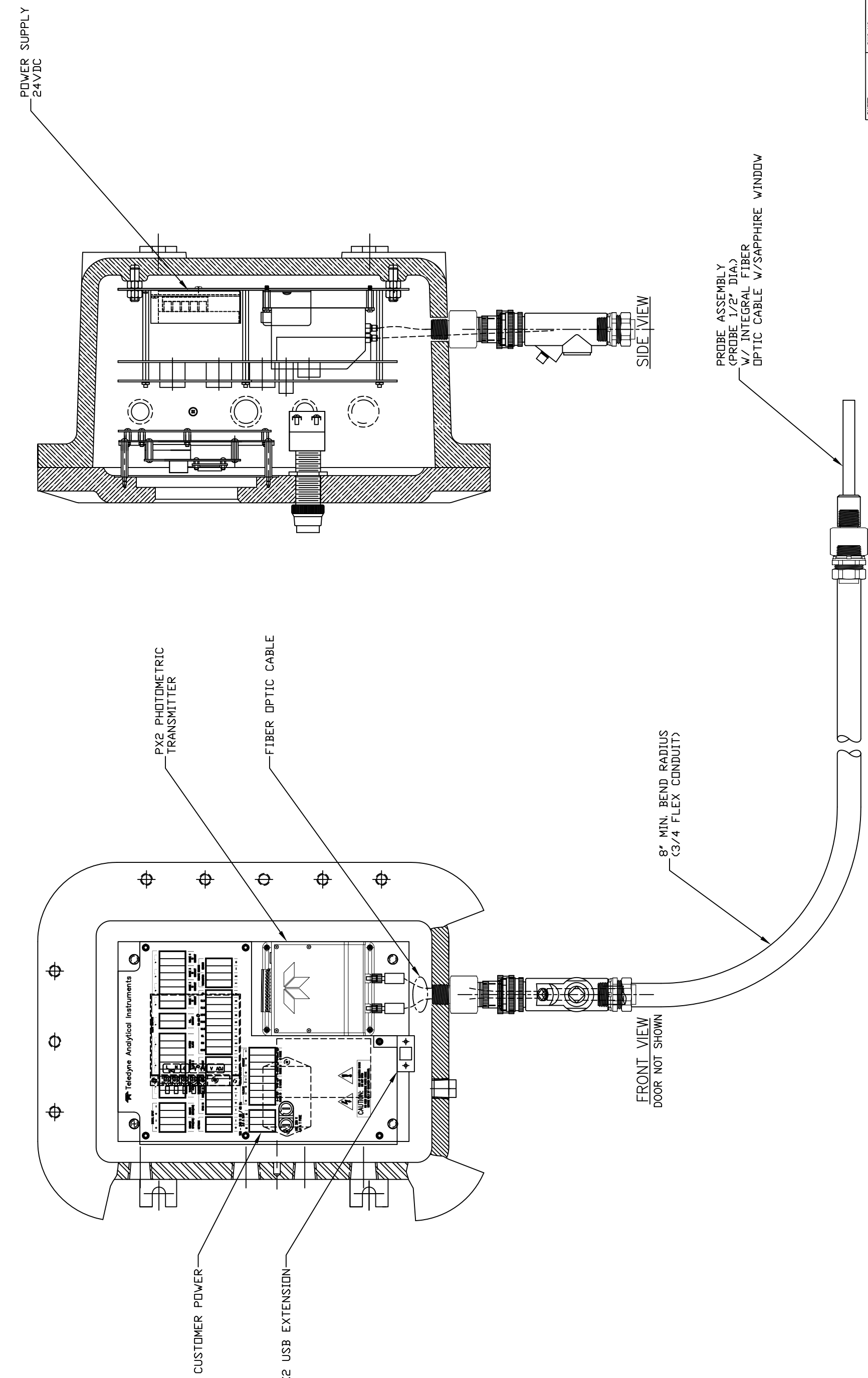

D

C

B

A

D

C

B

A

1 2 3 4 5 6 7 8

1 2 3 4 5 6 7 8

NOTES: UNLESS OTHERWISE SPECIFIED.

- 1 ALL DIMENSIONS ARE IN INCHES (± 0.06) AND MILLIMETERS ($\pm 1.$): INCHES[MM].
- 2 AREA CLASS: II 2G Ex d IIB+H2 T6 Gb.
3. ALL CELLS/BATTERIES TO BE REMOVED.
4. NO RADIO, LASER, AND ULTRASONIC EQUIPMENT FITTED.
5. MINIMUM 40% OF EACH CROSS-SECTIONAL AREA REMAINS FREE.

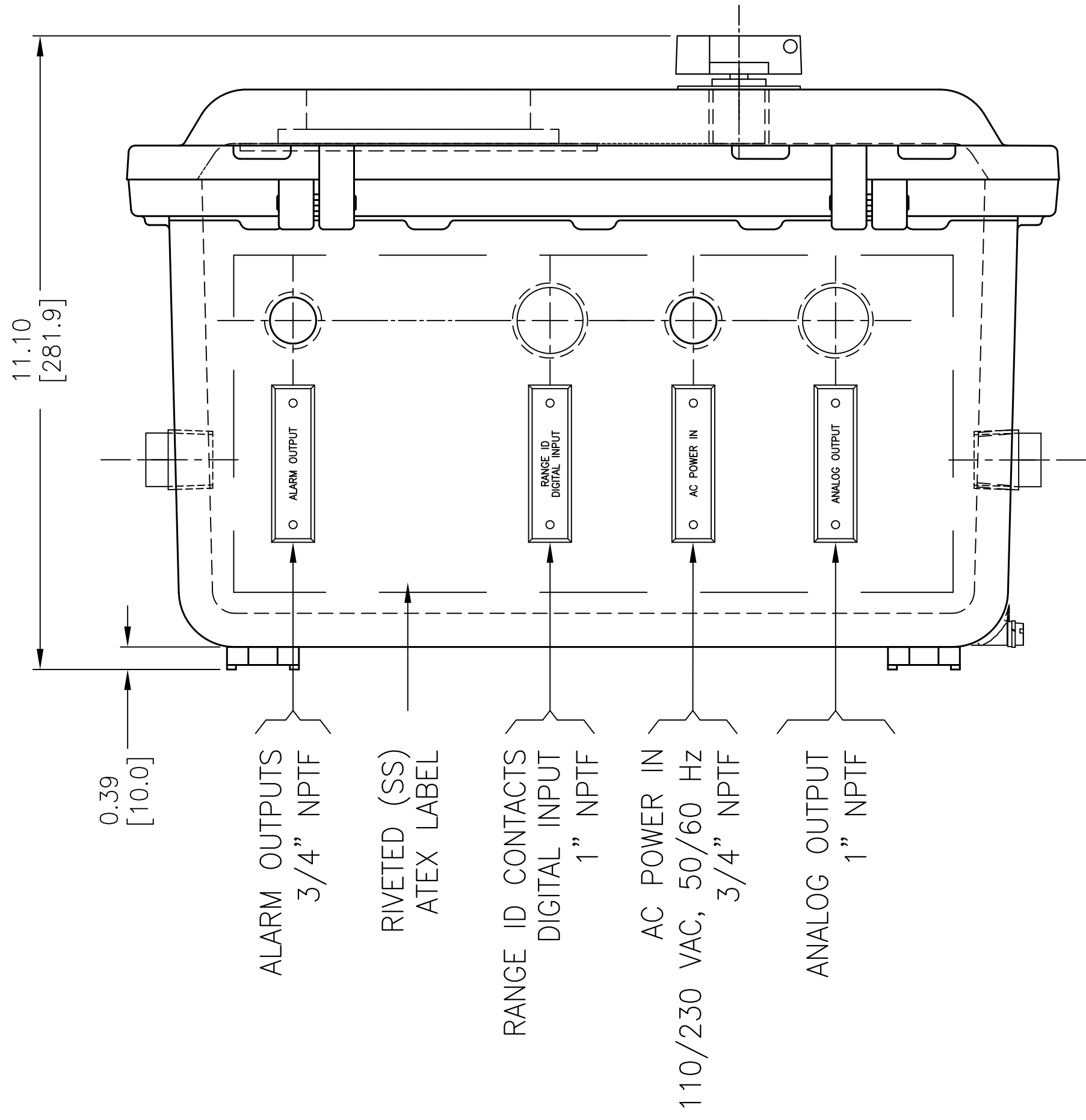

SIDE VIEW

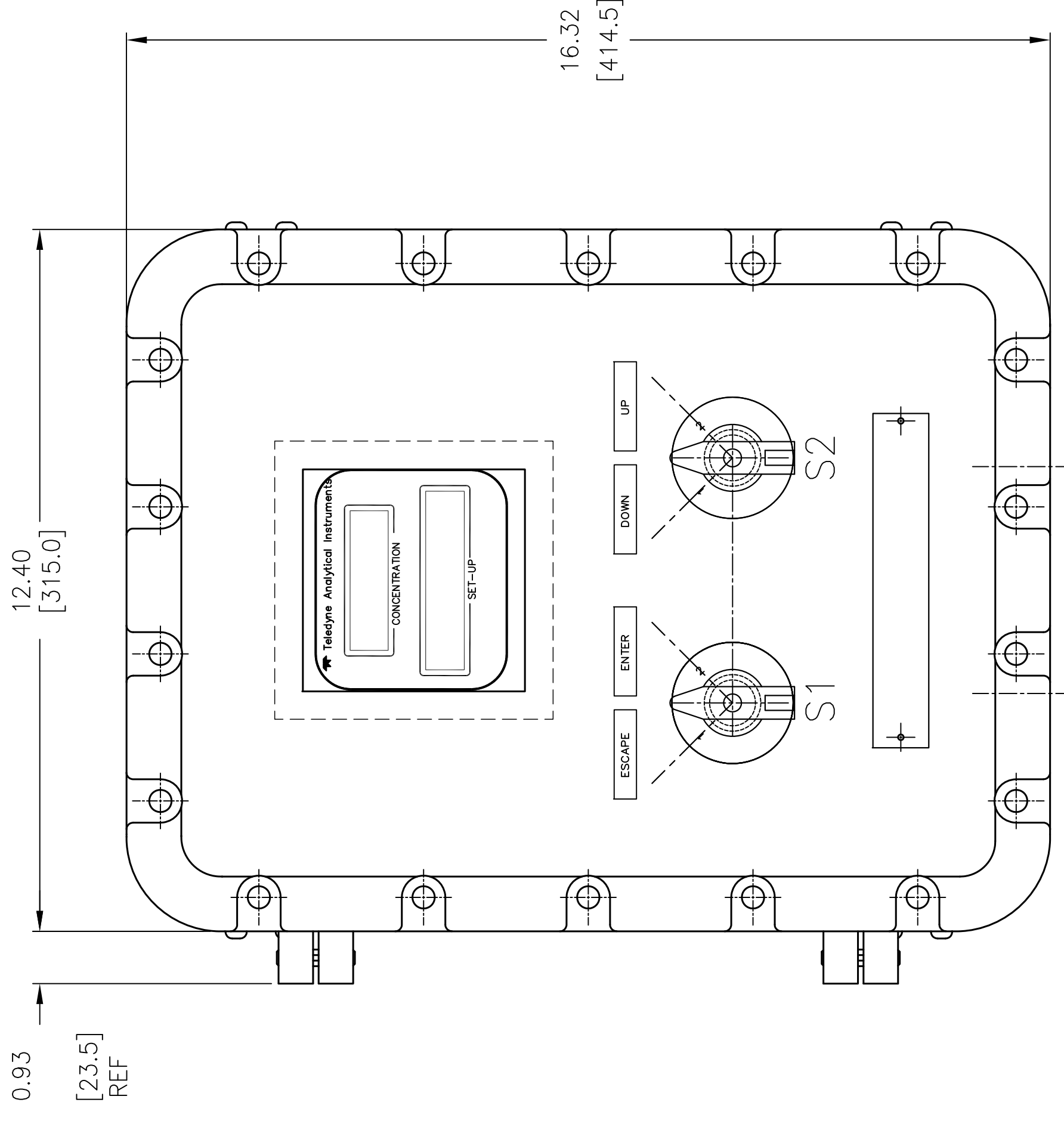

FRONT VIEW

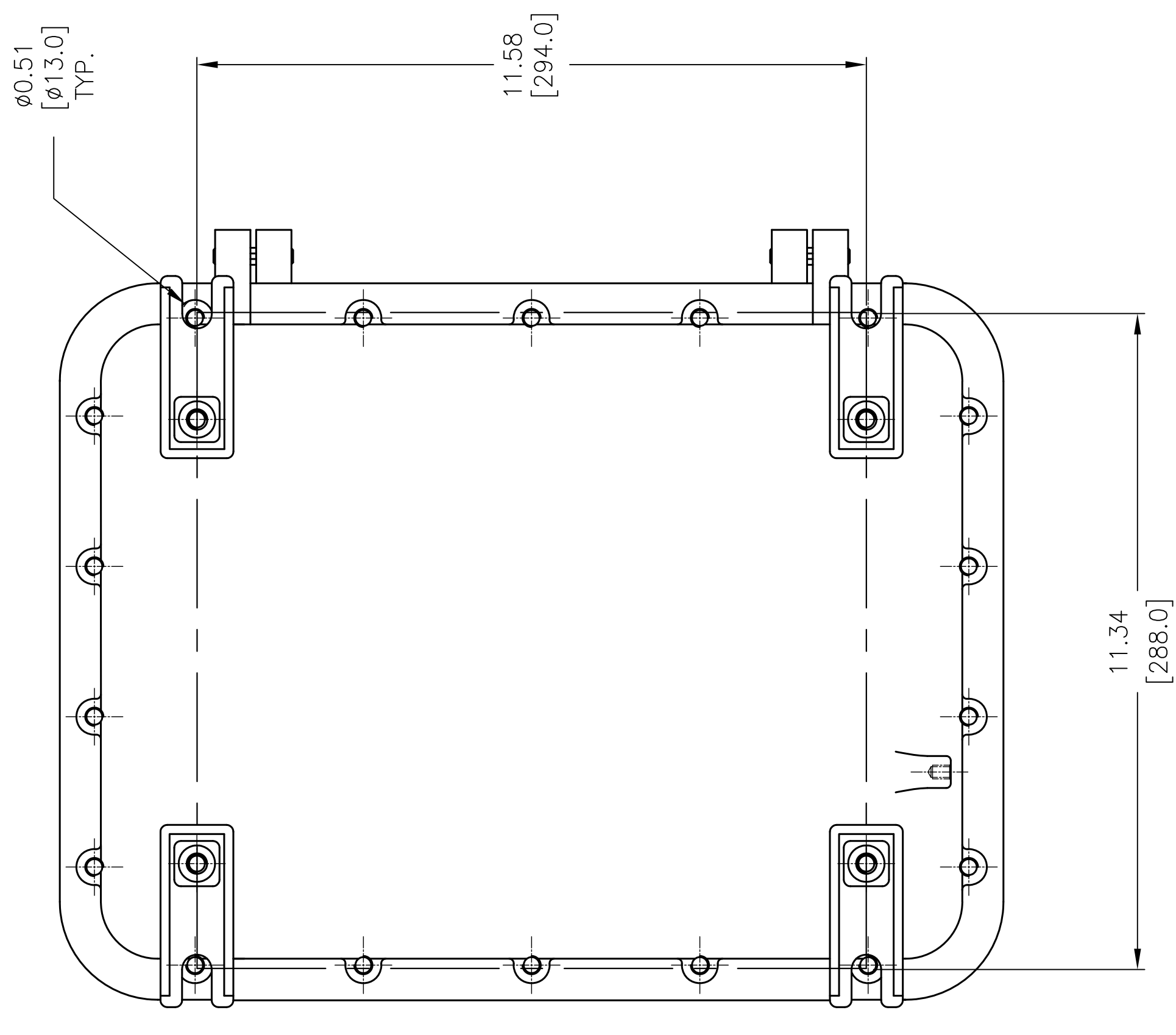

BACK VIEW
MOUNT DIMENSIONS

ATEX Certified Product
No modification permitted
without reference to
Intertek

REV	DESCRIPTION	DATE	APP.	REV.
0	INITIAL RELEASE	03/24/16	WP	---

REVISIONS

ITEM	QTY	PART NO.	DESCRIPTION
BILL OF MATERIAL			
DO NOT SCALE DRAWING UNLESS OTHERWISE SPECIFIED DIMENSIONS ARE IN INCHES DIMENSIONS ARE IN INCHES ANGULAR $\pm 1/2'$ LINEAR ± 0.02 ANGULAR $\pm 1/2'$ LINEAR ± 0.01			
TELEDYNE Analytical Instruments A Business Unit of Teledyne Instruments, Inc. City of Industry, California 91748, USA			
THE DRAWING IS THE PROPERTY OF TELEDYNE ANALYTICAL INSTRUMENTS AND CONTAINS CONFIDENTIAL INFORMATION. IT IS NOT TO BE COPIED, REPRODUCED OR USED WITHOUT WRITTEN PERMISSION.			
SIGNATURES			TITLE
N/	DRET: W PORTACIO	03/24/16	SCALE 1:2
I/	CHK: C93391		SIM D93252
O/	APPR:		SHEET 1 OF 4
F/	ENGR: W PORTACIO		REV
F/	C.O. STANDARD		DWG NO. D-93493
REFERENCE	CAD ID D93493-0		0

ITEM	QTY	PART NO.	DESCRIPTION
BILL OF MATERIAL			
DO NOT SCALE DRAWING UNLESS OTHERWISE SPECIFIED DIMENSIONS ARE IN INCHES DIMENSIONS ARE IN INCHES ANGULAR $\pm 1/2'$ LINEAR ± 0.02 ANGULAR $\pm 1/2'$ LINEAR ± 0.01			
TELEDYNE Analytical Instruments A Business Unit of Teledyne Instruments, Inc. City of Industry, California 91748, USA			
THE DRAWING IS THE PROPERTY OF TELEDYNE ANALYTICAL INSTRUMENTS AND CONTAINS CONFIDENTIAL INFORMATION. IT IS NOT TO BE COPIED, REPRODUCED OR USED WITHOUT WRITTEN PERMISSION.			
SIGNATURES			TITLE
N/	DRET: W PORTACIO	03/24/16	SCALE 1:2
I/	CHK: C93391		SIM D93252
O/	APPR:		SHEET 1 OF 4
F/	ENGR: W PORTACIO		REV
F/	C.O. STANDARD		DWG NO. D-93493
REFERENCE	CAD ID D93493-0		0

OUTLINE DIAGRAM OIW
ANALYZER MDL6650SP-XD
ATEX CONTROL UNIT

ITEM	QTY	PART NO.	DESCRIPTION
BILL OF MATERIAL			
DO NOT SCALE DRAWING UNLESS OTHERWISE SPECIFIED DIMENSIONS ARE IN INCHES DIMENSIONS ARE IN INCHES ANGULAR $\pm 1/2'$ LINEAR ± 0.02 ANGULAR $\pm 1/2'$ LINEAR ± 0.01			
TELEDYNE Analytical Instruments A Business Unit of Teledyne Instruments, Inc. City of Industry, California 91748, USA			
THE DRAWING IS THE PROPERTY OF TELEDYNE ANALYTICAL INSTRUMENTS AND CONTAINS CONFIDENTIAL INFORMATION. IT IS NOT TO BE COPIED, REPRODUCED OR USED WITHOUT WRITTEN PERMISSION.			
SIGNATURES			TITLE
N/	DRET: W PORTACIO	03/24/16	SCALE 1:2
I/	CHK: C93391		SIM D93252
O/	APPR:		SHEET 1 OF 4
F/	ENGR: W PORTACIO		REV
F/	C.O. STANDARD		DWG NO. D-93493
REFERENCE	CAD ID D93493-0		0

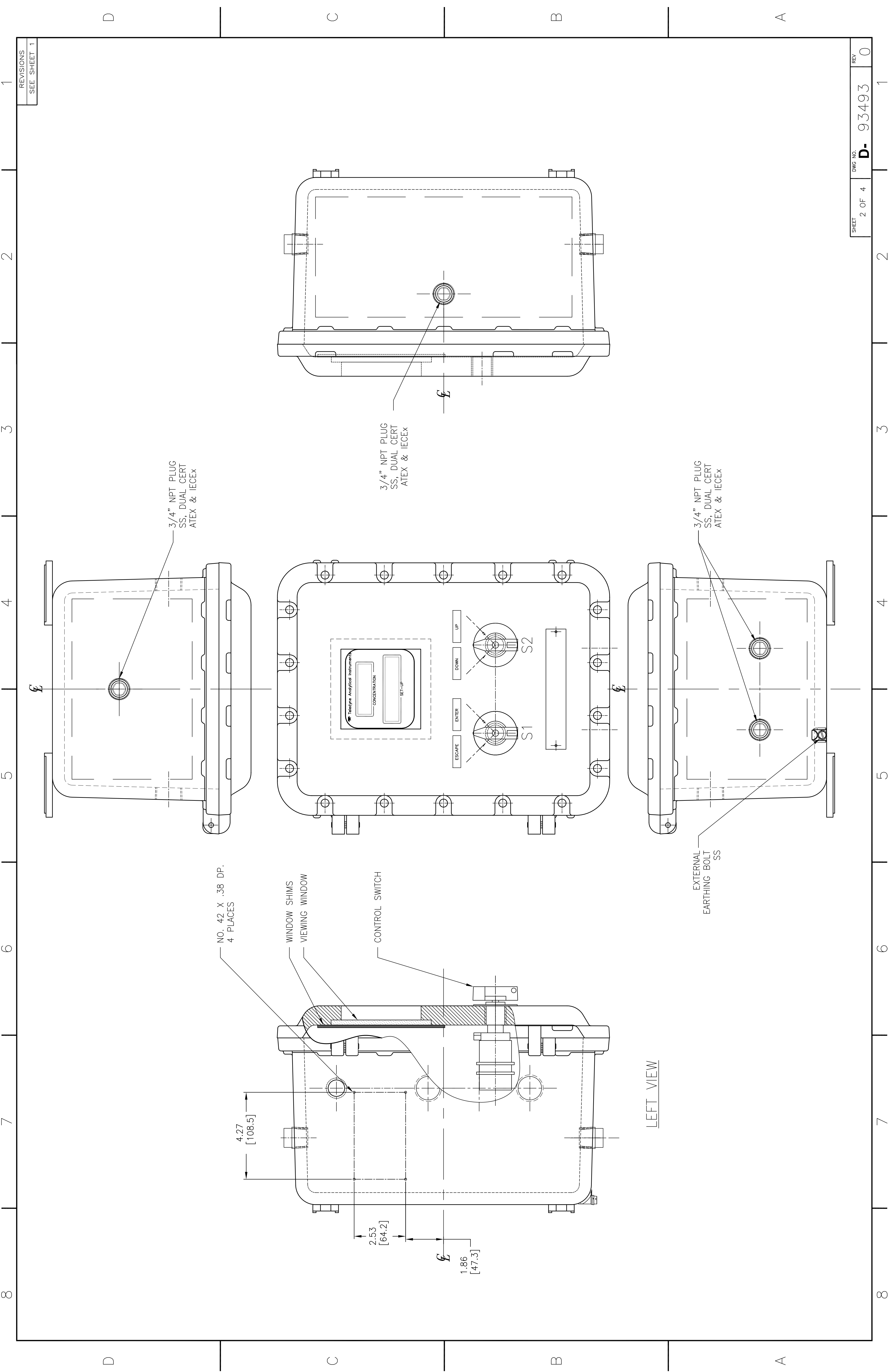

D

C

B

A

1 2 3 4 5 6 7 8

REVISIONS
SEE SHEET 1

SHEET 2 OF 4

DWG NO. **D-** 93493

REV 0

3/4" NPT PLUG
SS, DUAL CERT
ATEX & IECEx

3/4" NPT PLUG
SS, DUAL CERT
ATEX & IECEx

3/4" NPT PLUG
SS, DUAL CERT
ATEX & IECEx

NO. 42 X .38 DP.
4 PLACES

WINDOW SHIMS
VIEWING WINDOW

CONTROL SWITCH

EXTERNAL
EARTHING BOLT
SS

4.27
[108.5]

2.53
[64.2]

1.86
[47.3]

LEFT VIEW

D

C

B

A

REVISIONS
SEE SHEET 1

SHEET 3 OF 4
DWG NO. **D-**93493
REV 0

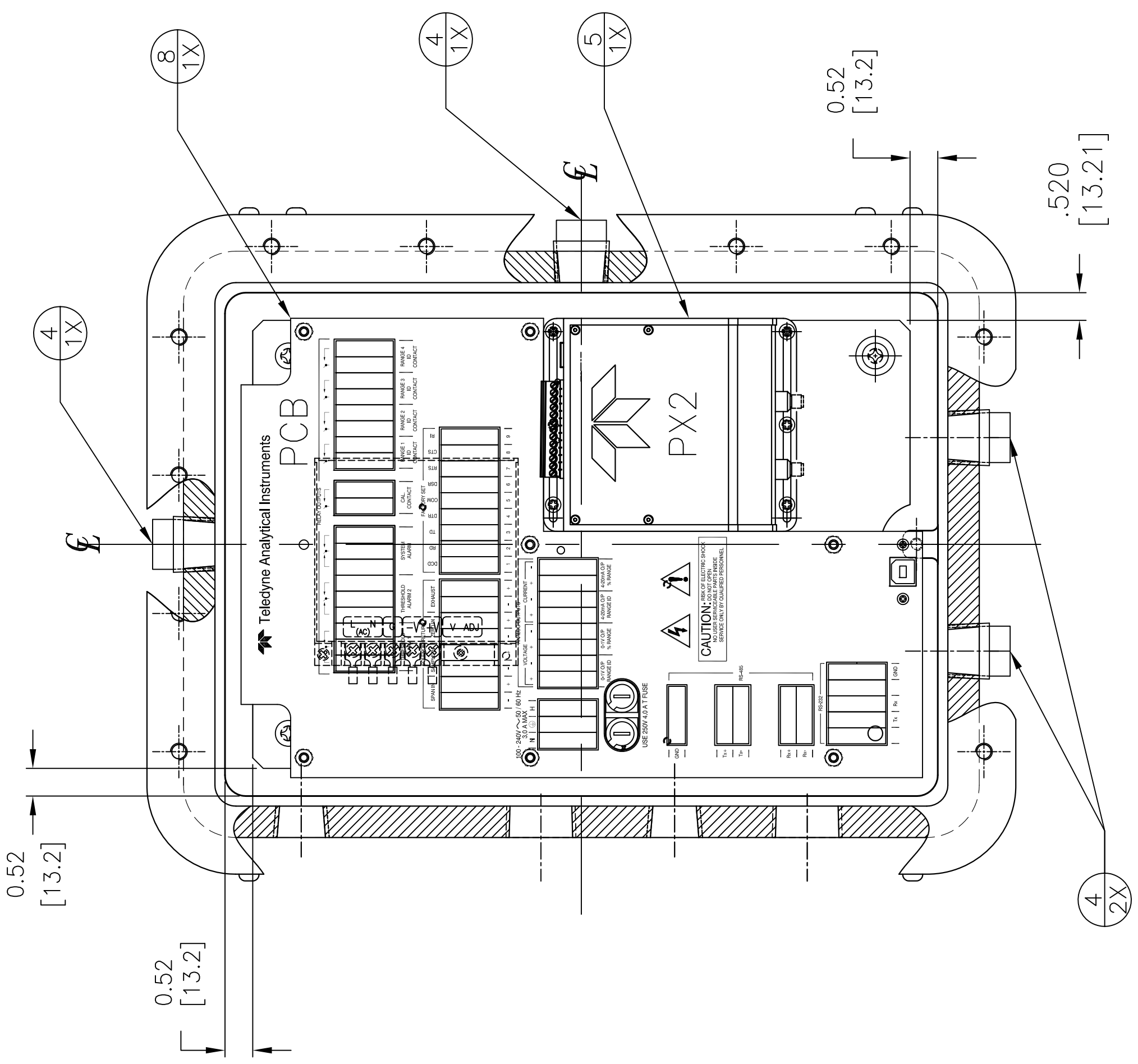

DOOR REMOVED

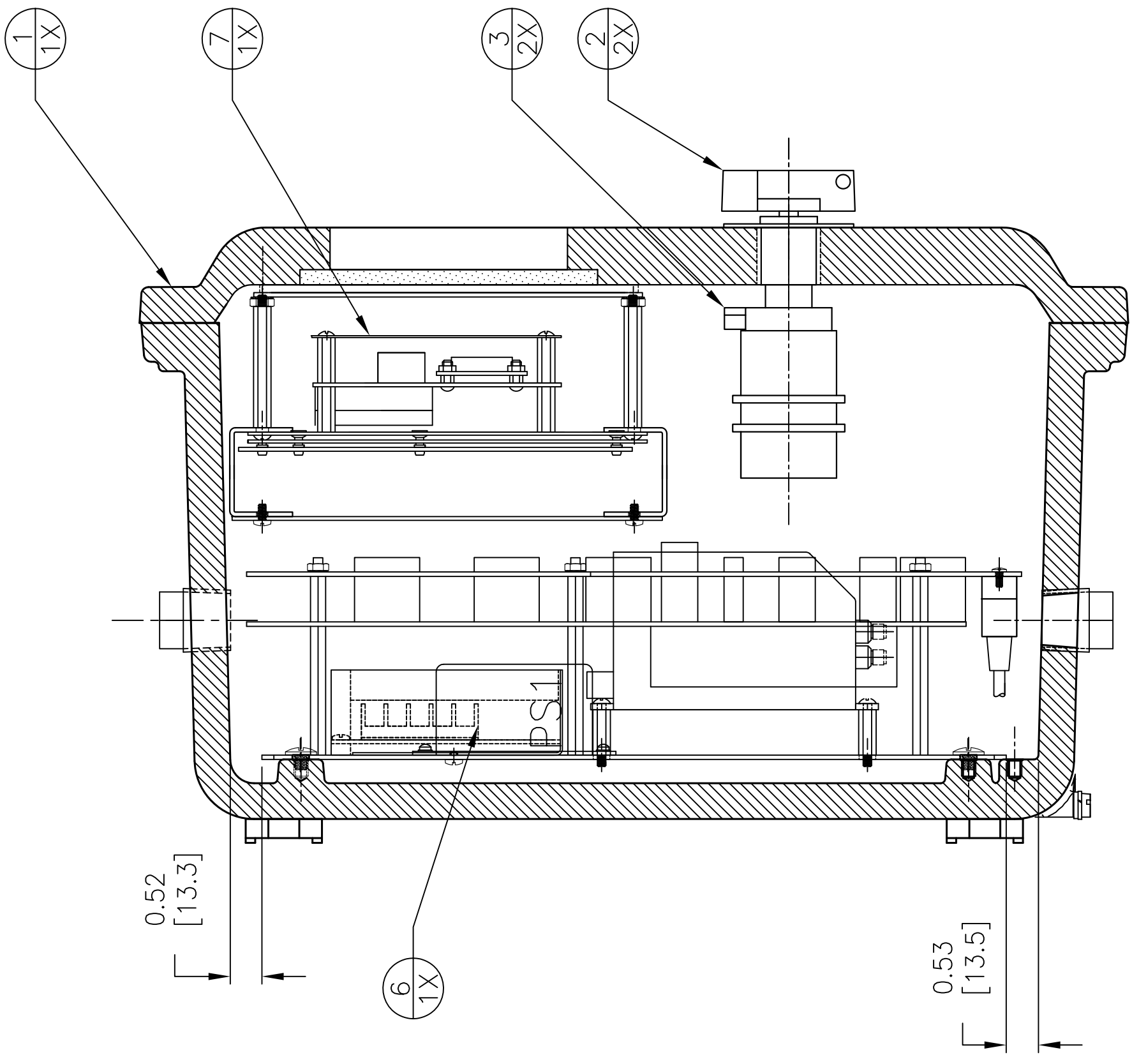

LEFT VIEW
CUT-AWAY

D

C

B

A

1 2 3 4 5 6 7 8

1 2 3 4 5 6 7 8

8 7 6 5 4 3 2 1

D C B A

REVISIONS
SEE SHEET 1

ITEM	UNIT QTY	P/N	DESCRIPTION	REF	MFG	ATEX CERT NO.	IECEX CERT NO.	MFG P/N
1	1	H1038	DRILLING DETAIL JUNCTION BOX FEAM EJB-31 MODEL 6650SP-XD ATEX	-	FEAM	INERIS 13ATEX9019U	INE 13.0083U	EJB31
2	2	-----	ROTARY HANDLES	S1, S2	FEAM	INERIS 13ATEX9017U	INE 13.0073U	EFI-RL
3	2	S 2037	SWITCH, CONTACT BLOCK, 2-POLE, 3-POS SELECTOR SWITCH 1-0-2, CENTER SPRING RETURN FOR EJB ENCLOSURE, ATEX APPROVED	S1, S2	ITALWEBER	-----	-----	Z1080#01437
4	4	P 2098	PLUG, 3/4" NPT, SS, DUAL CERT ATEX & IECEX DUAL CERT ATEX & IECEX	-	HLS	SIRA 07ATEX1175X	SIR 07.0048X	D5.34-HLS
5	1	AP 465	ANALYZER, UV FLUORESCENCE TRANSMITTER, PX2	PX2	CST	-----	-----	6310-10-200-210-0
6	1	P 1962	POWER SUPPLY SINGLE OUTPUT 24V 2.2AMPS 52.8WATT INPUT 100-240VAC 1.3A 50/60HZ	PS1	ASTRODYNE	-----	-----	RS-50-24
7	1	C93210B	6650 MAIN BOARD, DUAL 4-20mA OUTPUT, RS485-4 WIRE	PCB	TELEDYNE	-----	-----	CP3210B
	1	C93210E	6650 MAIN BOARD, DUAL 4-20mA OUTPUT, RS485-2 WIRE	PCB	TELEDYNE	-----	-----	C93210E
8	1	C93213A	6650 CUSTOMER INTERFACE PCB - 2 WIRES RS485	PCB	TELEDYNE	-----	-----	C93213A
	1	C93213B	6650 CUSTOMER INTERFACE PCB-4 WIRES RS485	PCB	TELEDYNE	-----	-----	C93213B

SHEET 4 OF 4
DWG NO. D-93493
REV 0

8 7 6 5 4 3 2 1