

---

## OPERATING INSTRUCTIONS

# Model 6000B

## Photometric Analyzer

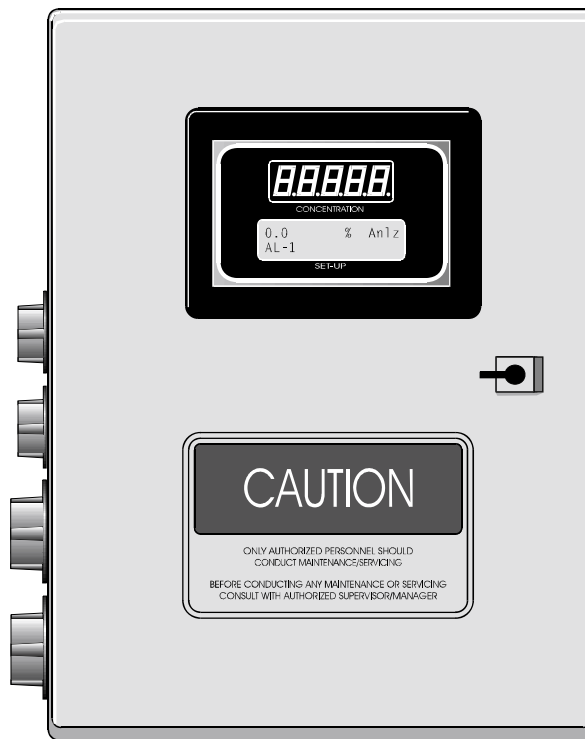

### DANGER



HIGHLY TOXIC AND OR FLAMMABLE LIQUIDS OR GASES MAY BE PRESENT IN THIS MONITORING SYSTEM.

PERSONAL PROTECTIVE EQUIPMENT MAY BE REQUIRED WHEN SERVICING THIS SYSTEM.

HAZARDOUS VOLTAGES EXIST ON CERTAIN COMPONENTS INTERNALLY WHICH MAY PERSIST FOR A TIME EVEN AFTER THE POWER IS TURNED OFF AND DISCONNECTED.

ONLY AUTHORIZED PERSONNEL SHOULD CONDUCT MAINTENANCE AND/OR SERVICING. BEFORE CONDUCTING ANY MAINTENANCE OR SERVICING CONSULT WITH AUTHORIZED SUPERVISOR/MANAGER.

P/N M67986  
11/24/04  
ECO# 03-0126

### Copyright © 1999 Teledyne Analytical Instruments

All Rights Reserved. No part of this manual may be reproduced, transmitted, transcribed, stored in a retrieval system, or translated into any other language or computer language in whole or in part, in any form or by any means, whether it be electronic, mechanical, magnetic, optical, manual, or otherwise, without the prior written consent of Teledyne Analytical Instruments, 16830 Chestnut Street, City of Industry, CA 91749-1580.

#### Warranty

This equipment is sold subject to the mutual agreement that it is warranted by us free from defects of material and of construction, and that our liability shall be limited to replacing or repairing at our factory (without charge, except for transportation), or at customer plant at our option, any material or construction in which defects become apparent within one year from the date of shipment, except in cases where quotations or acknowledgements provide for a shorter period. Components manufactured by others bear the warranty of their manufacturer. This warranty does not cover defects caused by wear, accident, misuse, neglect or repairs other than those performed by Teledyne or an authorized service center. We assume no liability for direct or indirect damages of any kind and the purchaser by the acceptance of the equipment will assume all liability for any damage which may result from its use or misuse.

We reserve the right to employ any suitable material in the manufacture of our apparatus, and to make any alterations in the dimensions, shape or weight of any parts, in so far as such alterations do not adversely affect our warranty.

#### Important Notice

This instrument provides measurement readings to its user, and serves as a tool by which valuable data can be gathered. The information provided by the instrument may assist the user in eliminating potential hazards caused by his process; however, it is essential that all personnel involved in the use of the instrument or its interface, with the process being measured, be properly trained in the process itself, as well as all instrumentation related to it.

The safety of personnel is ultimately the responsibility of those who control process conditions. While this instrument may be able to provide early warning of imminent danger, it has no control over process conditions, and it can be misused. In particular, any alarm or control systems installed must be tested and understood, both as to how they operate and as to how they can be defeated. Any safeguards required such as locks, labels, or redundancy, must be provided by the user or specifically requested of Teledyne at the time the order is placed.

Therefore, the purchaser must be aware of the hazardous process conditions. The purchaser is responsible for the training of personnel, for providing hazard warning methods and instrumentation per the appropriate standards, and for ensuring that hazard warning devices and instrumentation are maintained and operated properly.

Teledyne Analytical Instruments, the manufacturer of this instrument, cannot accept responsibility for conditions beyond its knowledge and control. No statement expressed or implied by this document or any information disseminated by the manufacturer or its agents, is to be construed as a warranty of adequate safety control under the user's process conditions.

**Table of Contents**

---

Specific Model Information ..... iv

Preface ..... v

Part I: Control Unit ..... Part I: 1-1

Part II: Analysis Unit ..... Part II: 1-1

Appendix ..... A-1



---

OPERATING INSTRUCTIONS

# Model 6000B

*Photometric Analyzer*

## Part I: Control Unit

NEMA 4 Bulkhead Mount

## Table of Contents

---

### 1 Introduction

1.1 Overview .....	1-1
1.2 Typical Applications .....	1-1
1.3 Main Features of the Analyzer .....	1-1
1.4 Control Unit Inner Interface Panel .....	1-2
1.5 Control Unit Interface Panel .....	1-2

### 2 Installation

2.1 Unpacking the Control Unit .....	2-1
2.2 Mounting the Control Unit .....	2-1
2.3 Electrical Connections .....	2-3
2.4 Testing the System .....	2-12

### 3 Operation

3.1 Introduction .....	3-1
3.2 Using the Data Entry and Function Buttons .....	3-1
3.3 The <i>System</i> Function .....	3-4
3.3.1 Setting up an Auto-Cal .....	3-4
3.3.2 Password Protection .....	3-6
3.3.2.1 Entering the Password .....	3-6
3.3.2.2 Installing or Changing the Password .....	3-7
3.3.3 Logging Out .....	3-8
3.3.4 System Self-Diagnostic Test .....	3-9
3.3.5 The Model Screen .....	3-10
3.3.6 Checking Linearity with Algorithm .....	3-10
3.3.7 Digital Filter Setup .....	3-11
3.3.8 Filter or Solenoid Setup .....	3-12
3.3.9 Hold/Track Setup .....	3-13
3.3.11 Calibration/Hold Timer Setup .....	3-14
3.3.12 Analog 4 to 20 mA Output Calibration .....	3-15
3.3.12 Model .....	3-15

---

3.3.13 Show Negative .....	3-15
3.4 The <i>Zero</i> and <i>Span</i> Functions .....	3-16
3.4.1 Zero Cal .....	3-16
3.4.1.1 Auto Mode Zeroing .....	3-16
3.4.1.2 Manual Mode Zeroing .....	3-17
3.4.1.3 Cell Failure .....	3-18
3.4.2 Span Cal .....	3-18
3.4.3 Offset Function .....	3-20
3.4.2.1 Auto Mode Spanning .....	3-19
3.4.2.2 Manual Mode Spanning .....	3-19
3.5 The <i>Alarms</i> Function .....	3-21
3.6 The <i>Range</i> Select Function .....	3-23
3.6.1 Manual (Select/Define Range) Screen .....	3-24
3.6.2 Auto Screen .....	3-24
3.6.3 Precautions .....	3-26
3.7 The <i>Analyze</i> Function .....	3-27
3.8 Programming .....	3-28
3.8.1 The Set Range Screen .....	3-28
3.8.2 The Curve Algorithm Screen .....	3-30
3.8.2.1 Manual Mode Linearization .....	3-30
3.8.2.2 Auto Mode Linearization .....	3-31
<b>4 Maintenance</b>	
4.1 Fuse Replacement .....	4-1
4.2 System Self Diagnostic Test .....	4-2
4.3 Major Internal Components .....	4-3
<b>A Appendix</b>	
Model 6000B Specifications .....	A-3





## Introduction

---

### 1.1 Overview

The Teledyne Analytical Instruments Model 6000B Control Unit, together with a 6000B Analysis Unit, is versatile microprocessor-based instrument.

Part I, of this manual covers the Model 6000B General Purpose NEMA 4 Bulkhead Mount Control Unit. (The Analysis Unit is covered in Part II of this manual.) The Control Unit is for indoor/outdoor use in a nonhazardous environment only. The Analysis Unit (or Remote Section) can be designed for a variety of hazardous environments.

### 1.2 Typical Applications

A few typical applications of the Model 6000B are:

- Oil in refinery waste water condensates Streams
- $CL_2$ , HC,  $SO_2$ ,  $H_2S$  in stack gases or Liquid Streams
- Chemical reaction monitoring
- Product Color monitoring liquids
- Petrochemical process control
- Quality assurance
- Phenol in water
- Hazardous waste incineration
- $CLO_2$ , Hypochlorite monitoring
- $F_2$  monitoring

### 1.3 Main Features of the Analyzer

The Model 6000B Photometric Analyzer is sophisticated yet simple to use. The main features of the analyzer include:

- A 2-line alphanumeric display screen, driven by microprocessor electronics, that continuously prompts and informs the operator.
- High resolution, accurate readings of concentration from low ppm levels through to 100%. Large, bright, meter readout.
- Versatile analysis over a wide range of applications.
- Microprocessor based electronics: 8-bit CMOS microprocessor with 32 kB RAM and 128 kB ROM.
- Three user definable output ranges (from 0-1 ppm through 0-100 %) allow best match to users process and equipment.
- Calibration range for convenient zeroing or spanning.
- Auto Ranging allows analyzer to automatically select the proper preset range for a given measurement. Manual override allows the user to lock onto a specific range of interest.
- Two adjustable concentration alarms and a system failure alarm.
- Extensive self-diagnostic testing, at startup and on demand, with continuous power-supply monitoring.
- RS-232 serial digital port for use with a computer or other digital communication device.
- Analog outputs for concentration and range identification. (0-1 V dc standard, and isolated 4–20 mA dc)
- Superior accuracy.
- Internal calibration (optional).

## 1.4 Control Unit Inner Control Panel

The standard 6000B Control Unit is housed in a rugged NEMA 4 metal case with all remote controls and displays accessible from the inner control panel. See Figure 1-1. The inner control panel has a digital meter, an alphanumeric Vacuum Fluorescent Display (VFD), and thirteen buttons for operating the analyzer.

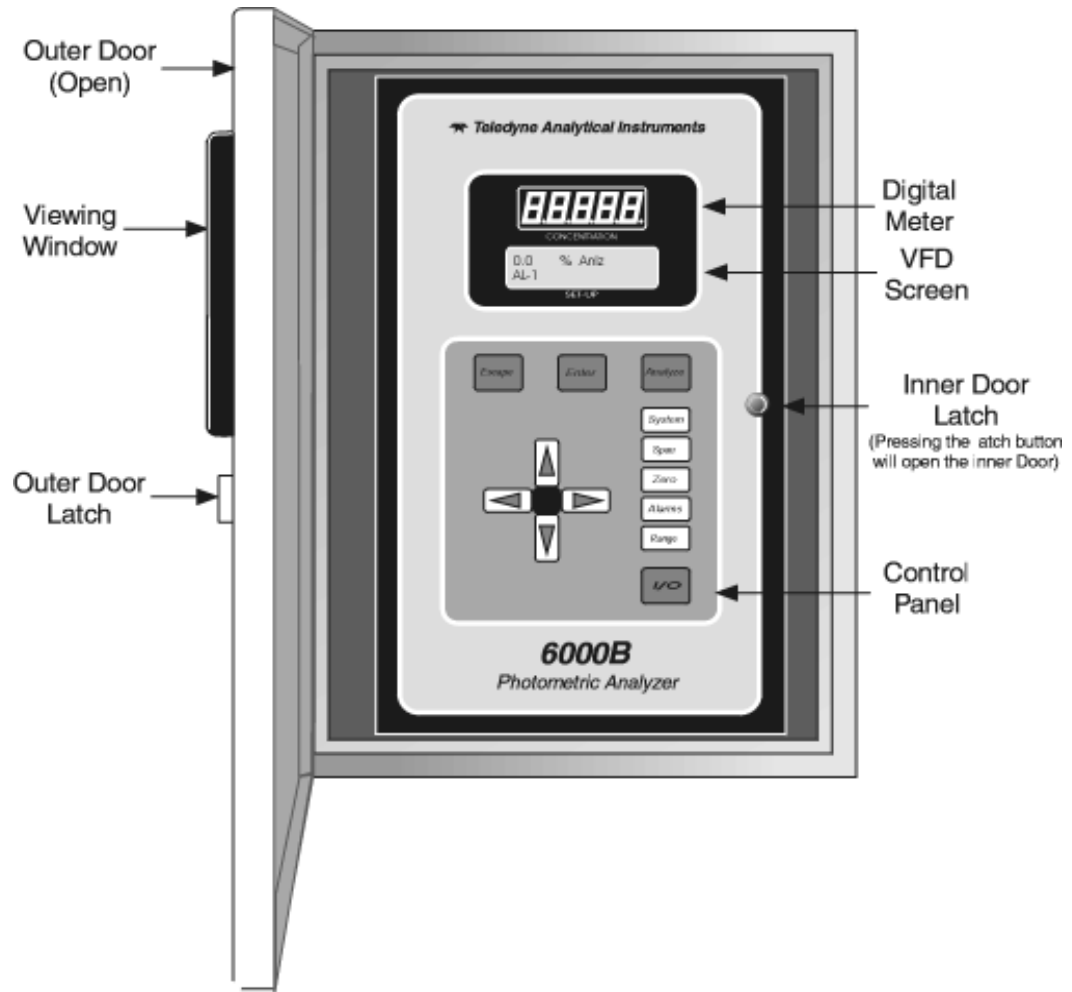

Figure 1-1: Front of Unmounted Control Unit

**Function Keys:** Six touch-sensitive membrane switches are used to change the specific function performed by the analyzer:

- **Analyze** Perform analysis for concentration content of a sample.
- **System** Perform system-related tasks (described in detail in chapter 3, *Operation*).
- **Span** Span calibrate the analyzer.
- **Zero** Zero calibrate the analyzer.
- **Alarms** Set the alarm setpoints and attributes.
- **Range** Set up the 3 user definable ranges for the instrument.



---

**Data Entry Keys:** Six touch-sensitive membrane switches are used to input data to the instrument via the alphanumeric VFD display:

- **Left & Right Arrows** Select between functions currently displayed on the VFD screen.
- **Up & Down Arrows** Increment or decrement values of functions currently displayed.
- **Enter** Moves VFD display on to the next screen in a series. If none remains, returns to the *Analyze* screen.
- **Escape** Moves VFD display back to the previous screen in a series. If none remains, returns to the *Analyze* screen.

**Digital Meter Display:** The meter display is a Light Emitting Diode LED device that produces large, bright, 7-segment numbers that are legible in any lighting. It is accurate across all analysis ranges. The 6000B models produce continuous readout from 0-10,000 ppm and then switch to continuous percent readout from 1-100 %.

**Alphanumeric Interface Screen:** The backlit VFD screen is an easy-to-use interface between operator and analyzer. It displays values, options, and messages for immediate feedback to the operator.

**I/O Power Button:** The red I/O button switches the instrument power between I (ON) and O (a Keep-Alive state). In the O state, the instrument's circuitry is operating, but there are no displays or outputs.

**CAUTION:** *The power must be disconnected to fully disconnect power from the instrument. When chassis is exposed or when access door is open and power cable is connected, use extra care to avoid contact with live electrical circuits .*

**Access Door:** For access to the electronics and interface panel, the front panel swings open when the latch in the panel is pressed all the way in with a narrow gauge tool. Accessing the main circuit board and other electronics requires unfastening the rear panel screws and sliding the unit out of the case.

## 1.5 Control Unit Interface Panel

The Control Unit interface panel, shown in Figure 1-2, contains the electrical terminal blocks for external inputs and outputs. The input/output functions are described briefly here and in detail in the *Installation* chapter of this manual.

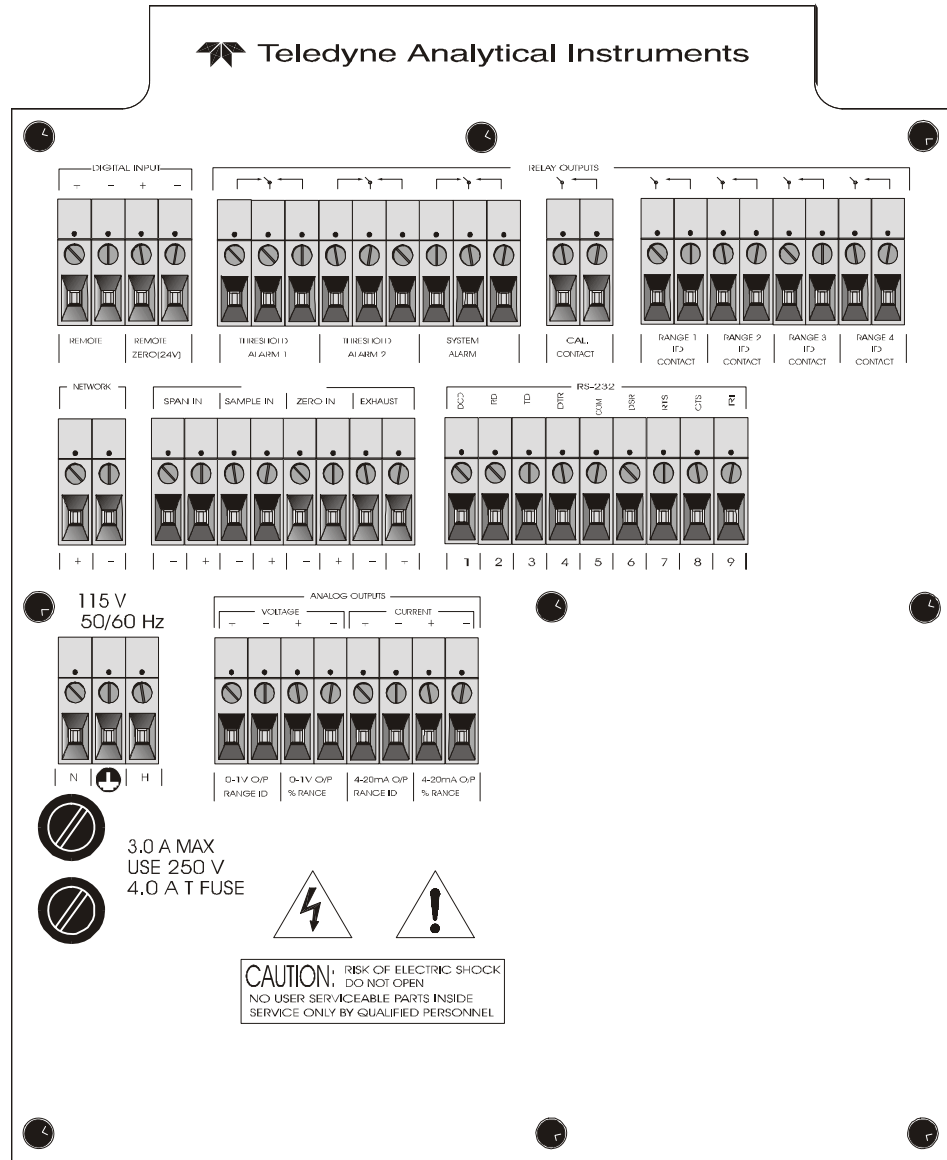

Figure 1-2: Model 6000B Rear Panel

- **Power Connection** AC power source, 115VAC, 50/60 Hz
- **Analog Outputs** 0-1 V dc concentration and 0-1 V dc range ID. Isolated 4-20 mA dc and 4-20 mA dc range ID.
- **Alarm Connections** 2 concentration alarms and 1 system alarm.
- **RS-232 Port** Serial digital concentration signal output and control input.
- **Remote Bench** Provides all electrical interconnect to the Analysis Unit.
- **Remote Span/Zero** Digital inputs allow external control of analyzer calibration.
- **Calibration Contact** To notify external equipment that instrument is being calibrated and readings are not monitoring sample.
- **Range ID Contacts** Four separate, dedicated, range relay contacts. Low, Medium, High, Cal.
- **Network I/O** Serial digital communications for local network access. For future expansion. Not implemented at this printing.

**Note:** If you require highly accurate Auto-Cal timing, use external Auto-Cal control where possible. The internal clock in the Model 6000B is accurate to 2-3 %. Accordingly, internally scheduled calibrations can vary 2-3 % per day.

## **Installation**

---

Installation of Model 6000B Analyzers includes:

1. Unpacking, mounting, and interconnecting the Control Unit and the Analysis Unit
2. Making gas connections to the system
3. Making electrical connections to the system
4. Testing the system.

This chapter covers installation of the Control Unit. (Installation of the Analysis Unit is covered in Part II of this manual.)

### **2.1 Unpacking the Control Unit**

The analyzer is shipped with all the materials you need to install and prepare the system for operation. Carefully unpack the Control Unit and inspect it for damage. Immediately report any damage to the shipping agent.

### **2.2 Mounting the Control Unit**

The Model 6000B Control Unit is for indoor/outdoor use in a general purpose area. **This Unit is NOT for any type of hazardous environments.**

Figure 2-1 is an illustration of a Model 6000B standard Control Unit front panel and mounting brackets as shown two mounting tabs are at the top and two at the bottom of the units frame.

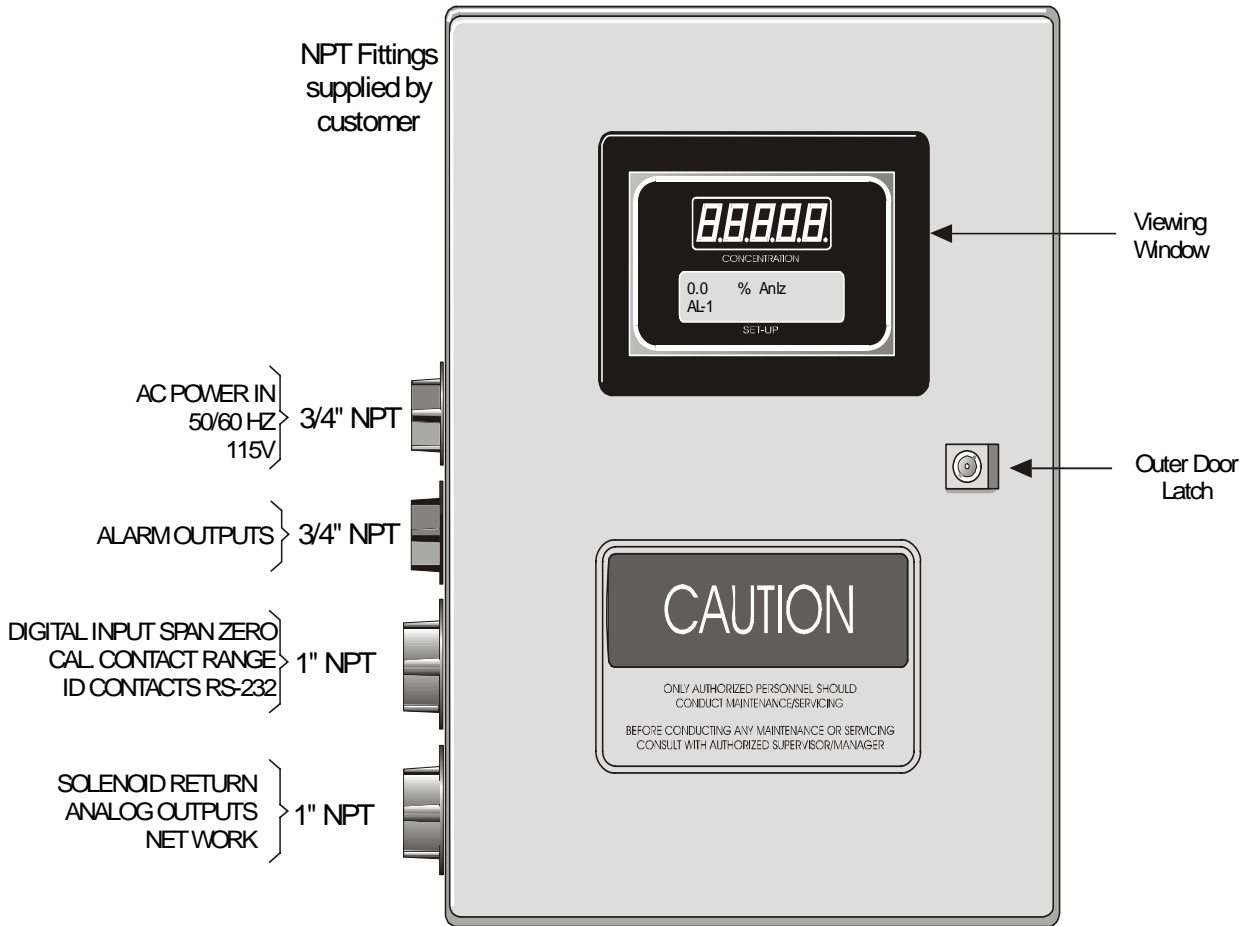

Figure 2-1: Front Panel of the Model 6000B Control Unit

All operator controls are mounted on the inner control panel "door", which is hinged on the left edge and doubles as a door to provide access to the internal components of the instrument. The door will swing open when the button of the latch is pressed all the way in with a narrow gauge tool (less than 0.18 inch wide), such as a small hex wrench or screwdriver



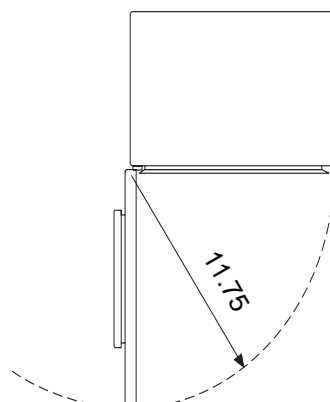

Figure 2-2: Required Front Door Clearance

Allow clearance for the door to open in a 90-degree arc of radius 11.75 inches. See Figure 2-2.

### 2.3 Electrical Connections

Figure 2-3 shows the Control Unit interface panel. Connections for power, communications, and both digital and analog signal outputs are described in the following paragraphs. Wire size and maximum length data appear in the Drawings at the back of this manual.

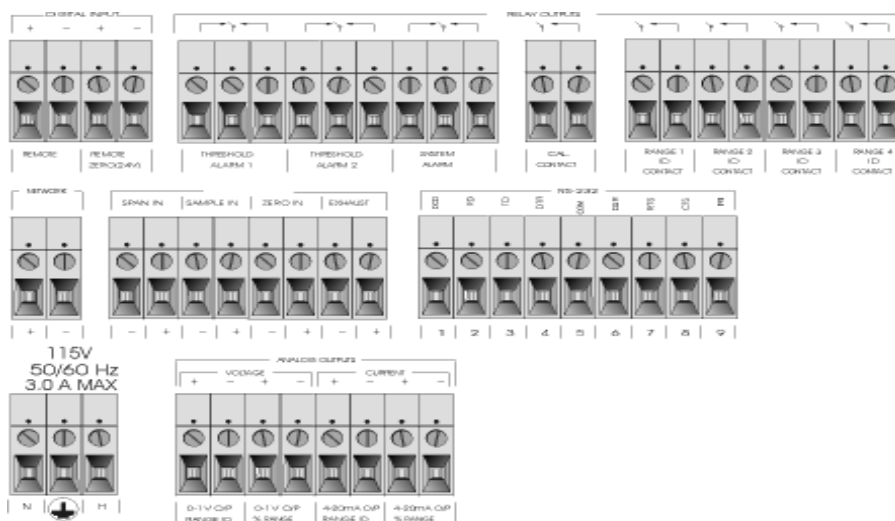

Figure 2-3: Interface Panel of the Model 6000B Control Unit

**For safe connections, ensure that no uninsulated wire extends outside of the terminal blocks.** Stripped wire ends must insert completely into terminal blocks. No uninsulated wiring should come in contact with fingers, tools or clothing during normal operation.

**Primary Input Power:** The power supply in the Model 6000B will accept a 115 Vac, 50/60 Hz power source. See Figure 2-4 for detailed connections.

**DANGER:** *Power is applied to the instrument's circuitry as long as the instrument is connected to the power source. The standby function switches power on or off to the displays and outputs only.*

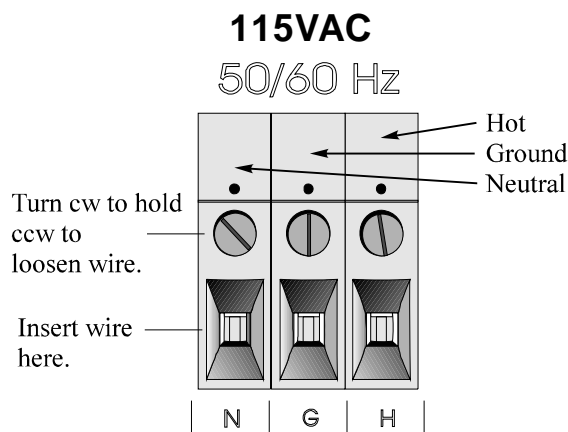

Figure 2-4: Primary Input Power Connections

**Fuse Installation:** The fuse holders accept 5 x 20 mm, 4.0 A, T type (slow blow) fuses. Fuses are not installed at the factory. Be sure to install the proper fuse as part of installation (See *Fuse Replacement* in chapter 4, *maintenance*.)

**Analog Outputs:** There are eight DC output signal connectors on the ANALOG OUTPUTS terminal block. There are two connectors per output with the polarity noted. See Figure 2-5.

The outputs are:

- 0–1 V dc % of Range: Voltage rises linearly with increasing sample concentration, from 0 V at 0% to 1 V at 100%. (Full scale = 100% programmed range.)
- 0–1 V dc Range ID: 0.25 V = Low Range, 0.5 V = Medium Range, 0.75 V = High Range, 1 V = Cal Range.

4–20 mA dc % Range: (-M Option) Current increases linearly with increasing sample concentration, from 4 mA at 0% to 20 mA at full scale 100%. (Full scale = 100% of programmed range.)

4–20 mA dc Range ID: (-M Option) 8 mA = Low Range, 12 mA = Medium Range, 16 mA = High Range, 20 mA = Cal Range.

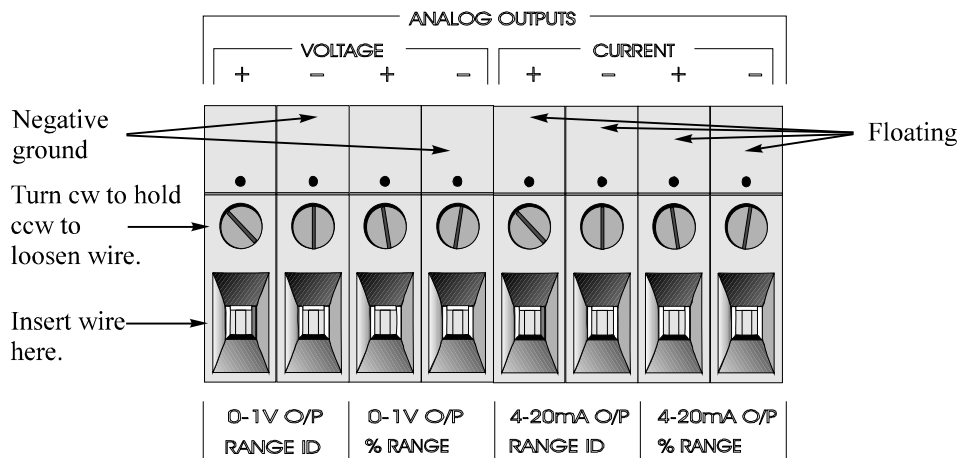

Figure 2-5: Analog Output Connections

**Examples:**

The analog output signal has a voltage which depends on the sample concentration AND the currently activated analysis range. To relate the signal output to the actual concentration, it is necessary to know what range the instrument is currently on, especially when the analyzer is in the autoranging mode.

The signal output for concentration is linear over currently selected analysis range. For example, if the analyzer is set on a range that was defined as 0-10 %, then the output would be as shown in Table 2-1.

**Table 2-1: Analog Concentration Output-Examples**

Analyte %	Voltage Signal Output (V dc)	Current Signal Output (mA dc)
0	0.0	4.0
1	0.1	5.6
2	0.2	7.2
3	0.3	8.8
4	0.4	10.4
5	0.5	12.0
6	0.6	13.6
7	0.7	15.2
8	0.8	16.8
9	0.9	18.4
10	1.0	20.0

To provide an indication of the range, a second pair of analog output terminals are used. They generate a steady preset voltage (or current when using the current outputs) to represent a particular range. Table 2-2 gives the range ID output for each analysis range.

**Table 2-2: Analog Range ID Output - Example**

Range	Voltage (V)	Current (mA)
LO	0.25	8
MED	0.50	12
HI	0.75	16
CAL (0-25%)	1.00	20

### Alarm Relays:

There are three alarm-circuit connectors on the alarm relays block (under RELAY OUTPUTS) for making connections to internal alarm relay contacts. Each provides a set of Form C contacts for each type of alarm. Each has both normally open and normally closed contact connections. The contact connections are indicated by diagrams on the rear panel. They are capable of switching up to 3 amperes at 250 V AC into a resistive load (Figure 2-6).

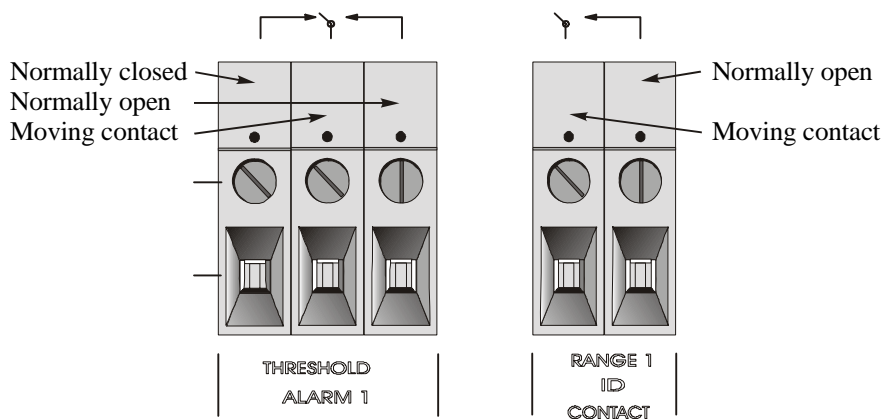

Figure 2-6: Types of Relay Contacts

The connectors are:

- Threshold Alarm 1:
- Can be configured as high (actuates when concentration is above threshold), or low (actuates when concentration is below threshold).
  - Can be configured as fail-safe or non-fail-safe.
  - Can be configured as latching or nonlatching.
  - Can be configured out (defeated).
- Threshold Alarm 2:
- Can be configured as high (actuates when concentration is above threshold), or low (actuates when concentration is below threshold).
  - Can be configured as fail-safe or non-fail-safe.
  - Can be configured as latching or nonlatching.
  - Can be configured out (defeated).
- System Alarm:
- Actuates when DC power supplied to circuits is unacceptable in one or more parameters. Permanently configured as fail-safe and latching. Cannot be defeated. Actuates if self test fails.

To reset a System Alarm during installation, disconnect power to the instrument and then reconnect it

Further detail can be found in chapter 3, section 4-5.

### Digital Remote Cal Inputs

**Remote Zero and Span Inputs:** The REMOTE SPAN and REMOTE ZERO inputs are on the DIGITAL INPUT terminal block. They accept 0 V (OFF) or 24 V dc (ON) for remote control of calibration (See *Remote Calibration Protocol below.*)

**Zero:** Floating input. 5 to 24 V input across the + and – terminals puts the analyzer into the **ZERO** mode. Either side may be grounded at the source of the signal. 0 to 1 volt across the terminals allows ZERO mode to terminate when done. A synchronous signal must open and close the external zero valve appropriately. See *Remote Probe Connector* at end of section 3.3. (With the -C option, the internal valves automatically operate synchronously).

**Span:** Floating input. 5 to 24 V input across the + and – terminals puts the analyzer into the **SPAN** mode. Either side may be grounded at the source of the signal. 0 to 1 volt across the terminals allows SPAN mode to terminate when done. A synchronous signal must open and close the external span valve appropriately. See *Remote Probe Connector* at end of section 3.3. (With the -C option, the internal valves automatically operate synchronously.)

**Cal Contact:** This relay contact is closed while analyzer is spanning and/or zeroing. (See *Remote Calibration Protocol below.*)

**Remote Calibration Protocol:** To properly time the Digital Remote Cal Inputs to the Model 6000B Analyzer, the customer's controller must monitor the Cal Relay Contact.

When the contact is OPEN, the analyzer is analyzing, the Remote Cal Inputs are being polled, and a zero or span command can be sent.

When the contact is CLOSED, the analyzer is already calibrating. It will ignore your request to calibrate, and it will not remember that request.

Once a zero or span command is sent, and acknowledged (contact closes), release it. If the command is continued until after the zero or span is complete, the calibration will repeat and the Cal Relay Contact (CRC) will close again.

For example:

- 1) Test the CRC. When the CRC is open, Send a zero command until the CRC closes (The CRC will quickly close.)
- 2) When the CRC closes, remove the zero command.
- 3) When CRC opens again, send a span command until the CRC closes. (The CRC will quickly close.)
- 4) When the CRC closes, remove the span command.

When CRC opens again, zero and span are done, and the sample is being analyzed.

**Note:** The Remote Bench connector (paragraph 3.3) provides signals to ensure that the zero and span gas valves will be controlled synchronously.

**Range ID Relays:** Four dedicated RANGE ID CONTACT relays . The first three ranges are assigned to relays in ascending order—Low range is assigned to RANGE 1 ID, Medium range is assigned to RANGE 2 ID, and High range is assigned to RANGE 3 ID.

**Network I/O:** A serial digital input/output for local network protocol. At this printing, this port is not yet functional. It is to be used in future versions of the instrument.

**RS-232 Port:** The digital signal output is a standard RS-232 serial communications port used to connect the analyzer to a computer, terminal, or other digital device. The pinouts are listed in Table 2-3.

**Table 2-3: RS-232 Signals**

RS-232 Sig	RS-232 Pin	Purpose
DCD	1	Data Carrier Detect
RD	2	Received Data
TD	3	Transmitted Data
DTR	4	Data Terminal Ready
COM	5	Common
DSR	6	Data Set Ready
RTS	7	Request to Send
CTS	8	Clear to Send
RI	9	Ring Indicator

The data sent is status information, in digital form, updated every two seconds. Status is reported in the following order:

- The concentration in percent
- The range is use (HI< MED< LO)
- The span of the range 0-100%, etc)
- Which alarm - if any - are disabled (AL-x DISABLED)
- Which alarms - if any - are tripped (AL-x ON)

Each status output is followed by a carriage return and line feed.

Three input functions using RS-232 have been implemented to date. They are described in Table 2-4.

**Table 2-4: Commands via RS-232 Input**

Command	Description
as<enter>	Immediately starts an autospan.
az<enter>	Immediately starts an autozero.
st<enter>	Toggling input. Stops/Starts any status message output from the RS-232, Until st<enter> is sent again.

The RS-232 protocol allows some flexibility in its implementation. Table 2-5 lists certain RS-232 values that are required by the 6110B.

**Table 2-5: Required RS-232 Options**

Parameter	Setting
Baud	2400
Byte	8 bits
Parity	none
Stop Bits	1
Message Interval	2 seconds

**Remote Bench and Solenoid Valves:** The 6000B is a single-chassis instrument. However, the REMOTE BENCH and SOLENOID RETURN connectors are provided on the interface PCB. The Remote Bench is wired at the factory as well as any optional solenoid valves included in the system.



## 2.4 Testing the System

**After** The Control Unit and the Analysis Unit are **both** installed and interconnected, and the system gas and electrical connections are complete, the system is ready to test. **Before** plugging either of the units into their respective power sources:

- Check the integrity and accuracy of the gas connections. Make sure there are no leaks.
- Check the integrity and accuracy of all electrical connections. Make sure there are no exposed conductors
- Check that sample pressure typically between 0 and 30 psig, according to the requirements of your process.

Power up the system, and test it by performing the following operation:

1. Repeat the Self-Diagnostic Test as.



---

## Operation

---

### 3.1 Introduction

Although the Model 6000B is usually programmed to your application at the factory, it can be further configured at the operator level, or even, **cautiously**, reprogrammed. Depending on the specifics of the application, this might include all or a subset of the following procedures:

- Setting system parameters:
  - Establish a security password, if desired, requiring Operator to log in (secure in safe file for reference).
  - Establish and start an automatic calibration cycle, if desired.
  
- Routine Operation:
  - Calibrate the instrument.
  - Choose autoranging or select a fixed range of analysis.
  - Set alarm setpoints, and modes of alarm operation (latching, fail-safe, etc).
  
- Program/Reprogram the analyzer:
  - Define new applications.
  - Linearize your ranges.

If you choose not to use password protection, the default password is automatically displayed on the password screen when you start up, and you simply press *Enter* for access to all functions of the analyzer.

### 3.2 Using the Data Entry and Function Buttons

**Data Entry Buttons:** The <> buttons select options from the menu currently being displayed on the VFD screen. The selected option blinks.

When the selected option includes a modifiable item, the  $\Delta$   $\nabla$  arrow buttons can be used to increment or decrement that modifiable item.

The **Enter** button is used to accept any new entries on the VFD screen. The **Escape** button is used to abort any new entries on the VFD screen that are not yet accepted by use of the **Enter** button.

Figure 4-1 shows the hierarchy of functions available to the operator via the function buttons. The six function buttons on the analyzer are:

- **Analyze.** This is the normal operating mode. The analyzer monitors the thermal conductivity of the sample, displays the percent or parts-per-million of target gas or contamination, and warns of any alarm conditions.
- **System.** The system function consists of nine subfunctions.

Four of these are for ordinary setup and operation:

- Setup an Auto-Cal
- Assign Passwords
- Log out to secure system
- Initiate a Self-Test

Three of the subfunctions do auxiliary tasks:

- Checking model and software version
- Adjust electronic filter of the signal
- Display more subfunctions
- Display negative readings

Two of these are for programming/reprogramming the analyzer:

- Define gas applications and ranges (Refer to programming section, or contact factory.)
- Use the Curve Algorithm to linearize output. (Refer to programming section, or contact factory.)
- **Zero.** Used to set up a zero calibration.
- **Span.** Used to set up a span calibration.
- **Alarms.** Used to set the alarm setpoints and determine whether each alarm will be active or defeated, HI or LO acting, latching, and/or fail-safe.
- **Range.** Used to set up three analysis ranges that can be switched automatically with autoranging or used as individual fixed ranges.

Any function can be selected at any time by pressing the appropriate button (unless password restrictions apply). The order as presented in this manual is appropriate for an initial setup.

Each of these functions is described in greater detail in the following procedures. The VFD screen text that accompanies each operation is reproduced, at

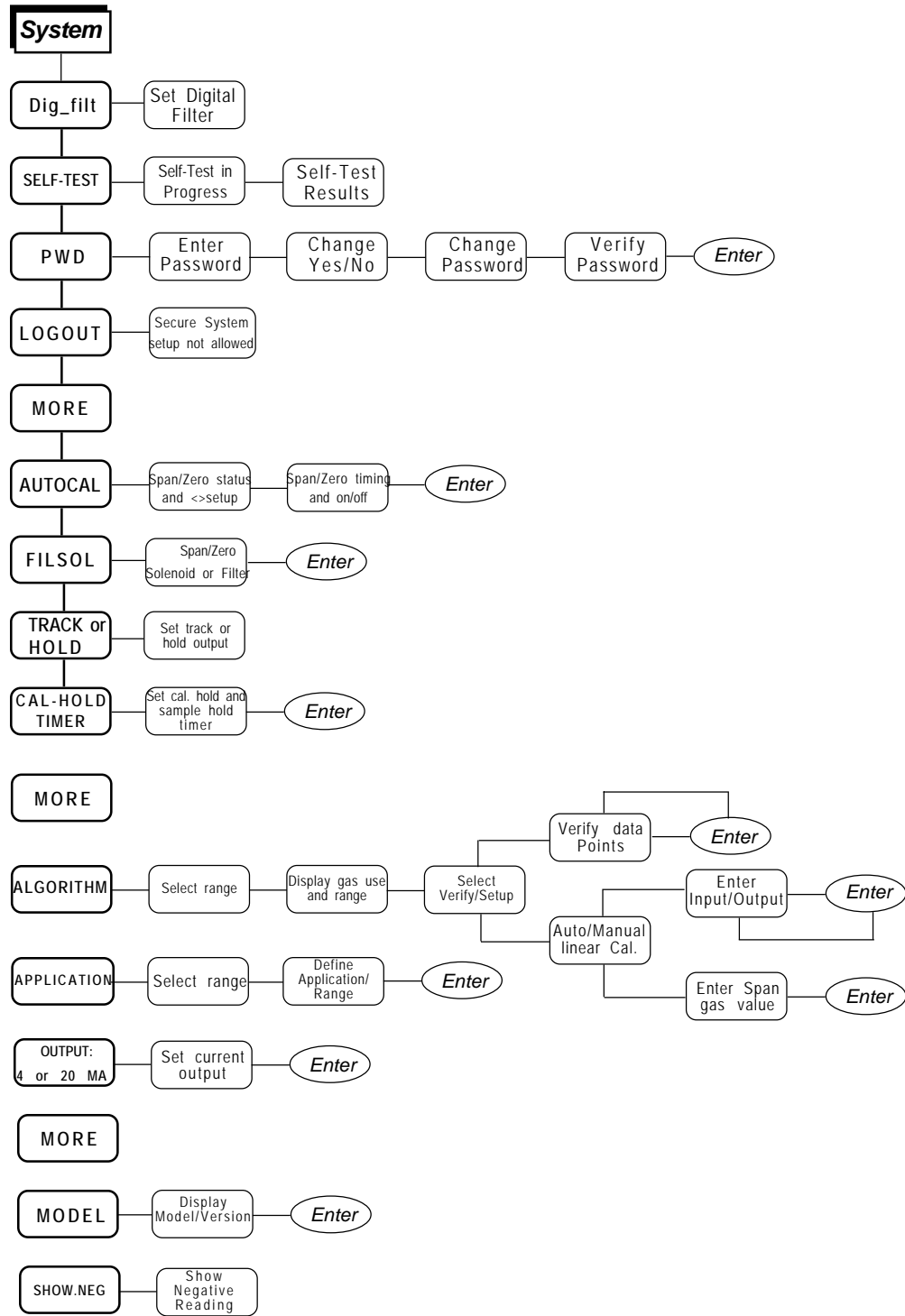

Figure 3-1: Hierarchy of System Functions and Subfunctions

the appropriate point in the procedure, in a `Monospaced` type style. Push-button names are printed in *Oblique* type.

### 3.3 The System Function

The subfunctions of the *System* function are described below. Specific procedures for their use follow the descriptions:

- **Dig\_Filt:** Adjust how much digital filtering should be on the signal
- **SELF-TEST:** Performs a self-diagnostic test to check the integrity of the power supplies, outputs, detector signal and preamplifier.
- **PWD:** Login security system for accessing to the setup functions.
- **LOGOUT:** Prevents an unauthorized tampering with analyzer settings.
- **AUTOCAL:** Set the automatic calibrated timer schedule for Zero and Span cycling.
- **FILSOL:** Select Span/Zero flag (filter) or Span/Zero solenoid valve for calibration method.
- **TRACK:** Set the system reading to be held or followed by the concentration “gas or filter” during calibration.
- **CAL-HOLD-TIMER:** Set the timing for calibration holding and timing for the sample reading after return to analyze mode.
- **ALGORITHM:** Linearize the output for nonlinear characteristic.
- **APPLICATION:** Used to define the analysis ranges and application (gas used).
- **MODEL:** Displays model number and software version.
- **OUTPUT:** 4-20 MA: Adjust 4 and 20 mA output.
- **SHOW\_NEG:** Whether to display negative readings or not; affects analog output too. No negative readings is the default.

#### 3.3.1 Setting up an AUTO-CAL

When proper automatic valving is connected, the Analyzer can cycle itself through a sequence of steps that automatically zero and span the instrument.

**Note:** Before setting up an AUTO-CAL, be sure you understand the *Zero* and *Span* functions as described in section 4.4, and follow the precautions given there.

**Note:** If you require highly accurate AUTO-CAL timing, use external AUTO-CAL control where possible. The internal clock in the Model 6000B is accurate to 2-3 %. Accordingly, internally scheduled calibrations can vary 2-3 % per day.

To setup an Auto-Cal cycle:

Choose *System* from the Function buttons. The VFD will display five subfunctions.

```
DIG_FILT SELF-TEST
PWD LOGOUT MORE
```

Select MORE and press the Enter Key

```
AUTOCAL          FILSOL      HOLD
CAL-HOLD-TIMER   MORE
```

Use < > arrows to blink AUTO-CAL, and press *Enter*. A new screen for ZERO/SPAN set appears.

```
ZERO in 0d 0h off
SPAN in 0d 0h off
```

Press < > arrows to blink ZERO (or SPAN), then press *Enter* again. (You won't be able to set OFF to ON if a zero interval is entered.) A Span Every ... (or Zero Every ...) screen appears.

```
Zero schedule: OFF
Day: 0d Hour: 0h
```

Use  $\Delta\nabla$  arrows to set an interval value, then use < > arrows to move to the start-time value. Use  $\Delta\nabla$  arrows to set a start-time value.

To turn ON the SPAN and/or ZERO cycles (to activate AUTO-CAL): Press *System* again, choose AUTO-CAL, and press *Enter* again. When the ZERO/SPAN values screen appears, use the < > arrows to blink the ZERO (or SPAN) and press *Enter* to go to the next screen. Use < > to select OFF/ON field. Use  $\Delta\nabla$  arrows to set the OFF/ON field to ON. You can now turn these fields ON because there is a nonzero span interval defined.

If instrument is turned off, the next time the instrument is powered, the instrument will automatically perform a calibration cycle after 3 minutes of entering the sample mode if AUTOCAL functions were on prior to shut down.

### 3.3.2 Password Protection

Before a unique password is assigned, the system assigns TAI by default. This password will be displayed automatically. The operator just presses the Enter key to be allowed total access to the instrument's features.

If a password is assigned, then setting the following system parameters can be done only after the password is entered: **alarm** setpoints, assigning a new **password, range/application** selections, and **curve algorithm** linearization. (APPLICATION and ALGORITHM are covered in the programming section.) However, the instrument can still be used for analysis or for initiating a self-test without entering the password. To defeat security the password must be changed back to TAI.

**NOTE: If you use password security, it is advisable to keep a copy of the password in a separate, safe location.**

#### 3.3.2.1 Entering the Password

To install a new password or change a previously installed password, you must key in and *ENTER* the old password first. If the default password is in effect, pressing the *ENTER* button will enter the default TAI password for you.

Press *System* to enter the *System* mode.

```
DIG_FILT  AUTO-CAL
PWD      LOGOUT  MORE
```

Use the < > arrow keys to scroll the blinking over to PWD, and press *Enter* to select the password function. Either the default TAI password or AAA place holders for an existing password will appear on screen depending on whether or not a password has been previously installed.

```
Enter password:
```

```
T A I
```

```
or
```

```
Enter password:
```

```
A A A
```

The screen prompts you to enter the current password. If you are not using password protection, press *Enter* to accept TAI as the default password. If a password has been previously installed, enter the password using the < > arrow keys to scroll back and forth between letters, and the  $\Delta \nabla$  arrow keys to change the letters to the proper password. Press *Enter* to enter the password.



In a few seconds, you will be given the opportunity to change this password or keep it and go on.

```
Change Password?
<ENT>=Yes  <ESC>=No
```

Press *Escape* to move on, or proceed as in *Changing the Password*, below.

### 3.3.2.2 Installing or Changing the Password

If you want to install a password, or change an existing password, proceed as above in *Entering the Password*. When you are given the opportunity to change the password:

```
Change Password?
<ENT>=Yes  <ESC>=No
```

Press *Enter* to change the password (either the default TAI or the previously assigned password), or press *Escape* to keep the existing password and move on.

If you chose *Enter* to change the password, the password assignment screen appears.

```
Select new password
T A I
```

Enter the password using the <> arrow keys to move back and forth between the existing password letters, and the  $\Delta$   $\nabla$  arrow keys to change the letters to the new password. The full set of 94 characters available for password use are shown in the table below.

#### Characters Available for Password Definition:

A	B	C	D	E	F	G	H	I	J
K	L	M	N	O	P	Q	R	S	T
U	V	W	X	Y	Z	[	¥	]	^
_	`	a	b	c	d	e	f	g	h
i	j	k	l	m	n	o	p	q	r
s	t	u	v	w	x	y	z	{	
}	→	!	"	#	\$	%	&	'	(
)	*	+	'	-	.	/	0	1	2
3	4	5	6	7	8	9	:	;	<
=	>	?	@						

When you have finished typing the new password, press *Enter*. A verification screen appears. The screen will prompt you to retype your password for verification.

Enter PWD To Verify:  
A A A

Use the arrow keys to retype your password and press *Enter* when finished. Your password will be stored in the microprocessor and the system will immediately switch to the *Analyze* screen, and you now have access to all instrument functions.

If all alarms are defeated, the *Analyze* screen appears as:

1.95 ppm SO<sub>2</sub>  
nR1: 0 - 10 Anlz

If an alarm is tripped, the second line will change to show which alarm it is:

1.95 ppm SO<sub>2</sub>  
AL-1

**NOTE:** If you log off the system using the LOGOUT function in the system menu, you will now be required to re-enter the password to gain access to Alarm, and Range functions.

### 3.3.3 Logging Out

The LOGOUT function provides a convenient means of leaving the analyzer in a password protected mode without having to shut the instrument off. By entering LOGOUT, you effectively log off the instrument leaving the system protected against use until the password is reentered. To log out, press the *System* button to enter the *System* function.

DIG\_FILT SELF-TEST  
PWD LOGOUT MORE

Use the <> arrow keys to position the blinking over the LOGOUT function, and press *Enter* to Log out. The screen will display the message:

Protected until  
password entered

### 3.3.4 System Self-Diagnostic Test

The Model 6000B has a built-in self-diagnostic testing routine. Pre-programmed signals are sent through the power supply, output board, preamp board and sensor circuit. The return signal is analyzed, and at the end of the test the status of each function is displayed on the screen, either as OK or as a number between 1 and 1024. (See *System Self Diagnostic Test* in chapter 4 for number code.) If any of the functions fails, the System Alarm is tripped.

**Note: The sensor will always show failed unless Zero gas is present in the sampling cell at the time of the SELF-TEST.**

The self diagnostics are run automatically by the analyzer whenever the instrument is turned on, but the test can also be run by the operator at will. To initiate a self diagnostic test during operation:

Press the *System* button to start the *System* function.

```
DIG_FILT SELF-TEST
PWD  LOGOUT  MORE
```

Use the < > arrow keys again to move the blinking to the SELF-TEST and press *Enter*. The screen will follow the running of the diagnostic.

```
RUNNING DIAGNOSTIC
Testing Preamp - Cell
```

When the testing is complete, the results are displayed.

```
Power: OK Analog: OK
Cell:  2 Preamp: 3
```

The module is functioning properly if it is followed by OK. A number indicates a problem in a specific area of the instrument. Refer to Chapter 5 *Maintenance and Troubleshooting* for number-code information. The results screen alternates for a time with:

```
Press Any Key
To Continue...
```

Then the analyzer returns to the initial System screen.

### 3.3.5 The Model Screen

Move the < > arrow key to MORE and press *Enter*. With MODEL blinking, press *Enter*. The screen displays the manufacturer, model, and software version information.

### 3.3.6 Checking Linearity with ALGORITHM

From the *System* Function screen, select ALGORITHM, and press *Enter*.

```
sel rng to set algo:
-> 01 02 03  <-
```

Use the <> keys to select the range: 01, 02, or 03. Then press *Enter*.

```
Gas Use:   SO2
Range:    0 - 10%
```

Press Enter again.

```
Algorithm setup:
VERIFY SET UP
```

Select and *Enter* VERIFY to check whether the linearization has been accomplished satisfactorily.

```
Dpt INPUT  OUTPUT
0  0.00    0.00
```

The leftmost digit (under Dpt) is the number of the data point being monitored. Use the  $\Delta\nabla$  keys to select the successive points.

The INPUT value is the input to the linearizer. It is the simulated output of the analyzer. **You do not need to actually flow gas.**

The OUTPUT value is the output of the linearizer. It should be the ACTUAL concentration of the span gas being simulated.

If the OUTPUT value shown is not correct, the linearization must be corrected. Press *ESCAPE* to return to the previous screen. Select and Enter SET UP to Calibration Mode screen. (set-up will not work without a PC being connected to the analyzer)

```
Select algorithm
mode : AUTO
```

There are two ways to linearize: AUTO and MANUAL: The auto mode requires as many calibration gases as there will be correction points along the curve. The user decides on the number of points, based on the precision required.

The manual mode only requires entering the values for each correction point into the microprocessor via the front panel buttons. Again, the number of points required is determined by the user.

### 3.3.7 Digital Filter Setup

The 6000B has the option of decreasing or increasing the amount filtering on the signal. This feature enhances the basic filtering done by the analog circuits by setting the amount of digital filtering effected by the microprocessing. To access the digital filter setup, you must:

1. Press the System key to start the System function

```

DIG_FILT    SELF-TEST
PWD LOGOUT  MORE

```

- DIG\_FILT will flash, press the ENTER key,

```

Weight of digital
Filter:    9

```

- The number on the second row will flash and can be set by using the Up or Down arrow keys.

The settings go from zero, no digital filtering, to 10, maximum digital filtering. The default setting is 8 and that should suffice for most applications. In some applications where speeding the response time with some trade off in noise is of value, the operator could decrease the number of the digital filter. In applications where the signal is noisy, the operator could switch to a higher number; the response time is slowed down though.

90% response time on the different settings to a step input is shown below. This response time does not include the contributions of the bench sampling system and the preamplifier near the detector.

Setting	90% Response time (seconds)
0	4.5
1	4.5
2	5.0
3	5.0
4	5.5
5	7.0
6	9.0
7	14.0
8	25.0
9	46.0
10	90.0

At a setting of “zero”, the response time is purely set by the electronics to 4.5 seconds. The numbers above can and will change depending on application and they merely serve to illustrate the effect of the digital filter.

### 3.3.8 Filter or Solenoid Setup

The 6000B can be spanned or zeroed by calibration gases or by the optical filters. The proper calibration method should be set at the factory. To access the Filter or Solenoid Flags, you must:

1. Press the System key to start the System function:

```
DIG_FILT SELF-TEST
PWD LOGOUT  MORE
```

2. Using the Right or Left arrow keys, select MORE and press Enter. The second System screen appears:

```
AUTOCAL FILSOL TRACK
CAL-HOLD-TIMER  MORE
```

3. Select FILSOL using the Right or Left arrow keys and press Enter to start the method of calibration function.

```
Set fil/sol for cal
Span: FIL Zero: SOL
```

There are two flag options: zero and/or span flags are chosen at time of purchase, one for Zero calibration and the other for Span located in the Detector housing. To move between the Zero and the Span flags, use the Right or Left arrow keys. FIL means that a filter will do this particular calibration. SOL means that the signal to activate a gas solenoid is enabled. To toggle between the SOL and FIL options, use the Up and Down arrow keys.

The connections to drive the filter and the solenoid are found on a strip terminal located on the interface board. The connections are described in section 5-6 of the maintenance section of the manual.

### 3.3.9 Hold/Track Setup

The 6000B has ability to disable the analog outputs and freeze the display while undergoing a scheduled or remote calibration. **The 6000B will track changes in the concentration if calibration is started through the front panel.** To setup this feature, the operator must:

1. Press the System key to start the System function:

```
DIG_FILT SELF-TEST
PWD LOGOUT  MORE
```

2. Using the Right or Left arrow keys, select MORE and press Enter. The Second System screen appears:

---

**AUTOCAL FILSOL TRACK  
CAL-HOLDER-TIMER MORE**

OR

**AUTOCAL FILSOL HOLD  
CAL-HOLD-TIMER MORE**

3. The option on the right of the first row can be set to TRACK or HOLD by using the UP or Down keys. By selecting the TRACK option, the analog outputs are enabled and with the display will track the concentration changes while the instrument is undergoing scheduled or remote calibration (either zero or span). By selecting the HOLD option, the analog outputs and display are disabled and will not track the concentration changes while the instrument is undergoing scheduled or remote calibration (either zero or span). In the HOLD option, the analog outputs and display will freeze on the last reading before entering calibration.

The analog outputs are both 0 to 1 volt outputs and both 4 to 20 mA outputs.

### 3.3.10 Calibration/Hold Timer Setup

This Calibration Timer lets the operator adjust the time the instrument purges the calibration gas prior to actually start the calibration computations. The Sample timer lets the operator adjust the time the instrument purges sample gas after finishing a calibration before it lets the analog outputs and display track the change in concentration.

This function and the TRACK/HOLD feature will prevent false alarms while performing remote or autoscheduled calibrations. These functions are not applicable if the calibration is initiated through the front panel. To enter the Calibration/Hold Timer function, you must:

1. Press the System key to start the System function:

**DIG\_FILT SELF-TEST  
PWD LOGOUT MORE**

2. Using the Right or Left arrow keys, select MORE and press Enter: The Second System screen appears:

**AUTOCAL FILSOL TRACK  
CAL-HOLD-TIMER MORE**

OR

---

```
AUTOCAL FILSOL HOLD
CAL-HOLD-TIMER MORE
```

3. Select with the Right or Left keys CAL-HOLD-TIMER, and press the Enter key to access this function menu:

```
Calbrt hold:    3 min
Sample hold:    1 min
```

The calibration hold time is set on the first row, while the sample hold time is set on the second row. To select one or the other, use the Right or Left keys. To modify the time of either timer, use the Up or Down keys. The time is in the minutes.

### 3.3.11 Analog 4 to 20 mA Output Calibration

This function will let the operator calibrate the 4 to 20 mA analog output to match the display reading. A DMM configured as a DC ammeter is needed. The DMM should be connected across the output terminals of the 4 to 20 mA output to monitor the output current. To enter the 4 to 20 mA output adjust function, you must:

1. Press the System key to start the System function:

```
DIG_FILT SELF-TEST
PWD LOGOUT MORE
```

2. Using the Right or Left arrow keys, select MORE and press Enter. The second System screen appears:

```
AUTOCAL FILSOL TRACK
CAL-HOLD-TIMER MORE
```

OR

```
AUTOCAL FILSOL HOLD
CAL-HOLD-TIMER MORE
```

3. Using the Right or the Left arrow keys, select MORE and press Enter. The third System screen appears:

```
ALGORITHM APPLICATION
MODEL OUTPUT:  4 MA
```

OR

```
ALGORITHM APPLICATION
MODEL OUTPUT:  20 MA
```



OUTPUT: 4 MA and OUTPUT: 20 MA can be toggled by moving on that field and pressing the Up or Down key. 4 mA output should be calibrated first and 20 mA output afterwards.

4. Select OUTPUT: 4 MA and press the Enter key

Use UP/DOWN arrow to

Adjust 4 ma:            250

The number on the second row is the setpoint of the 4 mA output. It is analogous to a potentiometer wiper. The number can be set anywhere from 0 to 500. The default is 250, in the middle. At the default setting, the output should be very close to 4 mA. If not, slowly adjust the number using the Up or the Down keys until DMM reads 4.00 mA. Press the Enter key when done.

5. Now select OUTPUT: 20 MA and press the Enter key. A screen similar to the one above will appear and the DMM should read close to 20 mA. If not, slowly adjust the number using the Up or Down key until DMM reads 20.0 mA. Press the Enter key when done.

The range of adjustment is approximately +/- 10% of scale (+/- 1.6 ma). Since the 4 to 20 mA output is tied to the 0 to 1 volt output, this function can be used to calibrate the 0 to 1 volt output, if the 4 to 20 mA output is not used. By using a digital Volt meter on the 0-1 Volt output.

### 3.3.12 Model

This selection in the System menu flashes for a few seconds the model number and the software version installed in this instrument.

### 3.3.13 Show Negative

The analyzer defaults to not to show negative readings on the analyze mode only. This affects the analog outputs too by pressing the UP or DOWN key, the analyzer can be set to display negative readings, on the SHOW\_NEG field of the system menu.

## 3.4 The Zero and Span Functions

The Model 6000B can have as many as three analysis ranges plus a special calibration range (Cal Range). Calibrating any one of the ranges will automatically calibrate the other ranges.

**CAUTION: Always allow 4-5 hours warm-up time before calibrating, if your analyzer has been disconnected from its**

**power source. This does not apply if the analyzer was plugged in but was in STANDBY.**

The analyzer is calibrated using zero, and span gases.

**Note: Shut off the gas pressure before connecting it to the analyzer, and be sure to limit pressure to 40 psig or less when turning it back on.**

Readjust the gas pressure into the analyzer until the flowrate through the Sample Cell settles between 50 to 200 cc/min (approximately 0.1 to 0.4 SCFH).

**Note: Always keep the calibration gas flow as close to the flowrate of the sample gas as possible**



### 3.4.1 Zero Cal

The **Zero** button on the front panel is used to enter the zero calibration function. Zero calibration can be performed in either the automatic or manual mode.

Make sure the zero gas is flowing to the instrument. If you get a CELL CANNOT BE BALANCED message while zeroing skip to section 4.4.1.3.

#### 3.4.1.1 Auto Mode Zeroing

Observe the precautions in sections 4.4 and 4.4.1, above. Press **Zero** to enter the zero function mode. The screen allows you to select whether the zero calibration is to be performed automatically or manually. Use the  $\Delta\nabla$  arrow keys to toggle between AUTO and MAN zero settling. Stop when AUTO appears, blinking, on the display.

```
Select zero
mode:  AUTO
```

Press **Enter** to begin zeroing.

```
####.## %      SO2
Slope=#.###  C-Zero
```

The beginning zero level is shown in the upper left corner of the display. As the zero reading settles, the screen displays and updates information on Slope= in percent/second (unless the Slope starts within the acceptable zero range and does not need to settle further). The system first does a coarse zero, shown in

the lower right corner of the screen as C—Zero, for 3 min, and then does a fine zero, and displays F—Zero, for 3 min.

Then, and whenever Slope is less than 0.01 for at least 3 min, instead of Slope you will see a countdown: 9 Left, 8 Left, and so fourth. These are software steps in the zeroing process that the system must complete, AFTER settling, before it can go back to *Analyze*. Software zero is indicated by S—Zero in the lower right corner.

```
####.## % SO2
4 Left=#.### S—Zero
```

The zeroing process will automatically conclude when the output is within the acceptable range for a good zero. Then the analyzer automatically returns to the *Analyze* mode.

### 3.4.1.2 Manual Mode Zeroing

Press *Zero* to enter the *Zero* function. The screen that appears allows you to select between automatic or manual zero calibration. Use the  $\Delta\nabla$  keys to toggle between AUTO and MAN zero settling. Stop when MANUAL appears, blinking, on the display.

```
Select zero
mode: MANUAL
```

Press *Enter* to begin the zero calibration. After a few seconds the first of three zeroing screens appears. The number in the upper left hand corner is the first-stage zero offset. The microprocessor samples the output at a predetermined rate.

```
####.## % SO2
Zero adj: 2048 C—Zero
```

The analyzer goes through C—Zero, F—Zero, and S—Zero. During C—Zero and F—Zero, use the  $\Delta\nabla$  keys to adjust displayed Zero adj: value as close as possible to zero. Then, press *Enter*.

S—Zero starts. During S—Zero, the Microcontroller takes control as in *Auto Mode Zeroing*, above. It calculates the differences between successive samplings and displays the rate of change as Slope= a value in parts per million per second (ppm/s).

```
####.## % SO2
Slope=#.### S—Zero
```

Generally, you have a good zero when Slope is less than 0.05 ppm/s for about 30 seconds.

Once zero settling completes, the information is stored in the analyzer's memory, and the instrument automatically returns to the *Analyze* mode.

### 3.4.1.3 Cell Failure

Detector failure in the 6000B is usually associated with inability to zero the instrument with a reasonable voltage differential between the reference and measure voltages. If this should ever happen, the 6000B system alarm trips, and the LCD displays a failure message.

**Detector cannot be balanced**  
**Check your zero gas**

Before optical balancing:

- a. Check your zero gas to make sure it is within specifications.
- b. Check for leaks downstream from the Sample Cell, where contamination may be leaking into the system.
- c. Check flowmeter to ensure that the flow is no more than 200 SCCM
- d. Check temperature controller board.
- e. Check gas temperature.
- f. Check the Sample Cell for dirty windows.

If none of the above, proceed to perform an optical balance as described in section 5.

## 3.4.2 Span Cal

The *Span* button on the front panel is used to span calibrate the analyzer. Span calibration can be performed in either the automatic or manual mode.

Make sure the span gas is flowing to the instrument.

### 3.4.2.1 Auto Mode Spanning

Observe all precautions in sections 3.4 and 3.4.2, above. Press *Span* to enter the span function. The screen that appears allows you to select whether the span calibration is to be performed automatically or manually. Use the  $\Delta$  and  $\nabla$  arrow keys to toggle between AUTO and MAN span settling. Stop when AUTO appears, blinking, on the display.

```
Select span
mode: AUTO
```

Press *Enter* to move to the next screen.

```
Span Val: 20.00 %
<ENT> To begin span
```

Use the <> arrow keys to toggle between the span concentration value and the units field (%/ppm). Use the  $\Delta\nabla$  arrow keys change the value and/or the units, as necessary. When you have set the concentration of the span gas you are using, press *Enter* to begin the Span calibration.

```
####.##%      SO2
Slope=#.###   Span
```

The beginning span value is shown in the upper left corner of the display. As the span reading settles, the screen displays and updates information on Slope. Spanning automatically ends when the span output corresponds, within tolerance, to the value of the span gas concentration. Then the instrument automatically returns to the analyze mode.

### 3.4.2.2 Manual Mode Spanning

Press *Span* to start the *Span* function. The screen that appears allows you to select whether the span calibration is to be performed automatically or manually.

```
Select span
mode: MANUAL
```

Use the  $\Delta\nabla$  keys to toggle between AUTO and MAN span setting. Stop when MAN appears, blinking, on the display. Press *Enter* to move to the next screen.

```
Span Val: 20.00 %
<ENT> To begin span
```

Use the <> arrow keys to toggle between the span concentration value and the units field (%/ppm). Use the  $\Delta\nabla$  arrow keys change the value and/or the units, as necessary. When you have set the concentration of the span gas you are using, press *Enter* to begin the Span calibration.

Press *Enter* to enter the span value into the system and begin the span calibration.

Once the span has begun, the microprocessor samples the output at a predetermined rate. It calculates the difference between successive samplings

and displays this difference as Slope on the screen. It takes several seconds for the first Slope value to display. Slope indicates rate of change of the Span reading. It is a sensitive indicator of stability.

```
####.##%   SO2
Slope=#.### Span
```

When the Span value displayed on the screen is sufficiently stable, press *Enter*. (Generally, when the Span reading changes by 1 % or less of the range being calibrated for a period of ten minutes it is sufficiently stable.) Once *Enter* is pressed, the Span reading changes to the correct value. The instrument then **automatically** enters the *Analyze* function.

### 3.4.3 Offset Function

This software when installed in the 6000B instruments provides a way to enter an offset on the zero operation of the analyser. This is useful when the instrument is zeroed in some inert gas such as Nitrogen or Argon, but the background gas of the process is different. If the background gas of the process is different than the zero calibration gas being used, the reading will have an offset that will be constant throughout its working range. Thus, the need to provide an offset when the instrument is being zeroed.

#### *How to access the offset function:*

To access this function, the instrument zero mode must be entered by pushing the Zero key on the front panel of the control unit. The VFD display will show the following menu selection:

```
Select zero
mode: AUTO
```

or

```
Select zero
mode: MAN
```

Select whether you want the instrument to do an automatic or manual zero. If you do an automatic zero, the instrument does the zero by itself. If you do a manual zero you must manually enter inputs to the instrument to accomplish the zero, see in the corresponding section of the manual on how this two functions differ.

When the Enter key is pressed, the following menu will appear:

```
Zero off: 0.0 ppm
<ENT> to begin Zero
```

---

The offset value can be modified by using the Up/Down keys. Next section shows how to select this value. Suffice to say that whatever value you enter, will be automatically added to the reading. Thus, if you entered -0.1 ppm, at the end of the zero the display will show -0.1 ppm.

Once the Enter key is pressed the instrument enters the zero mode. If you chose AUTO zero mode, the instrument will do the work of bringing the reading back to zero plus the offset value that was entered. If you chose MANual zero mode, then you must enter input to the instrument as explained in the corresponding section of the manual but with one difference: instead of bringing the display to read zero, you must make the display read zero plus the value entered as offset.

***How the offset value is selected:***

To find out what the offset value should be, the intended zero calibration gas and the a mix of the process background gas must be procured. This of course assumes that the zero gas and the process background gas are very different and that an offset will occur.

1. Let the intended zero calibration gas flow through the 6000 sample cell (this assumes that you have started up you system as recommended by the manual or technical personnel) and do a zero on the instrument. Leave the offset set to zero value.
2. At the end of the zero function, make sure the analyser reads zero.
3. Flow the process background gas mix through the 6000 sample cell on the Analyse mode. Wait for the reading to become stable. Write the reading down. Change the sign of the reading: This is the offset to be entered.
4. Do a manual run to check. Reintroduce the zero calibration gas. Start a zero on the analyser but this time enter the offset value.
5. At the end of the zero function, check that the instrument reads the entered offset.
6. Reintroduce the process background gas mix to the 6000 sample cell in the Analyse mode. It should read close to zero once the reading is stable (+/- 1% error of full scale).

***Spanning the 6000B:***

Since the instrument might be spanned with background gas the same as the zero calibration gas, the span value to be entered should be the span concentration plus the offset value (if the offset value has a minus sign then algebraically it becomes a subtraction).

### 3.5 The Alarms Function

The Model 6000B is equipped with 6 fully adjustable set points concentration with two alarms and a system failure alarm relay. Each alarm relay has a set of form "C" contacts rated for 3 amperes resistive load at 250 V ac. See Figure in Chapter 2, *Installation* and/or the Interconnection Diagram included at the back of this manual for relay terminal connections.

The system failure alarm has a fixed configuration described in chapter 2 *Installation*.

The concentration alarms can be configured from the front panel as either *high* or *low* alarms by the operator. The alarm modes can be set as *latching* or *non-latching*, and either *failsafe* or *non-failsafe*, or, they can be *defeated* altogether. The setpoints for the alarms are also established using this function.

Decide how your alarms should be configured. The choice will depend upon your process. Consider the following four points:

1. Which if any of the alarms are to be high alarms and which if any are to be low alarms?

Setting an alarm as HIGH triggers the alarm when the contaminant concentration rises above the setpoint. Setting an alarm as LOW triggers the alarm when the contaminant concentration falls below the setpoint.

Decide whether you want the alarms to be set as:

- Both high (high and high-high) alarms, or
- One high and one low alarm, or
- Both low (low and low-low) alarms.

2. Are either or both of the alarms to be configured as failsafe?

In failsafe mode, the alarm relay de-energizes in an alarm condition. For non-failsafe operation, the relay is energized in an alarm condition. You can set either or both of the concentration alarms to operate in failsafe or non-failsafe mode.

3. Are either of the alarms to be latching?

In latching mode, once the alarm or alarms trigger, they will remain in the alarm mode even if process conditions revert back to non-alarm conditions. This mode requires an alarm to be recognized before it can be reset. In the non-latching mode, the alarm status will terminate when process conditions revert to non-alarm conditions.

4. Are either of the alarms to be defeated?



The defeat alarm mode is incorporated into the alarm circuit so that maintenance can be performed under conditions which would normally activate the alarms.

The defeat function can also be used to reset a latched alarm. (See procedures, below.)

If you are using password protection, you will need to enter your password to access the alarm functions. Follow the instructions in section 3.3.3 to enter your password. Once you have clearance to proceed, enter the *Alarm* function.

Press the *Alarm* button on the front panel to enter the *Alarm* function.

Use the  $\Delta\nabla$  keys to choose between % or ppm units. Then press *Enter* to move to the next screen.

```
AL1: 1000 ppm HI
Dft:N Fs:N Ltch:N
```

Five parameters can be changed on this screen:

- Value of the alarm setpoint, AL1: #####
- Out-of-range direction, HI or LO
- Defeated? Dft:Y/N (Yes/No)
- Failsafe? Fs:Y/N (Yes/No)
- Latching? Ltch:Y/N (Yes/No).
- To define the setpoint, use the < > arrow keys to move the blinking over to AL1: #####. Then use the  $\Delta\nabla$  arrow keys to change the number. Holding down the key speeds up the incrementing or decrementing.
- To set the other parameters use the < > arrow keys to move the blinking over to the desired parameter. Then use the  $\Delta\nabla$  arrow keys to change the parameter.
- Once the parameters for alarm 1 have been set, press *Alarms* again, and repeat this procedure for alarm 2 (AL2).
- To reset a latched alarm, go to Dft- and then press either  $\Delta$  two times or  $\nabla$  two times. (Toggle it to Y and then back to N.)

–OR –

Go to Ltch- and then press either  $\Delta$  two times or  $\nabla$  two times. (Toggle it to N and back to Y.)

### 3.6 The *Range* Select Function

The *Range* function allows you to manually select the concentration range of analysis (MANUAL), or to select automatic range switching (AUTO).

In the MANUAL screen, you are further allowed to define the high and low (concentration) limits of each Range, and select a single, fixed range to run.

**CAUTION: If this is a linearized application, the new range must be within the limits previously programmed using the System function, if linearization is to apply throughout the range. Furthermore, if the limits are too small a part (approx 10 % or less) of the originally linearized range, the linearization will be compromised.**

#### 3.6.1 Manual (Select/Define Range) Screen

The Manual range-switching mode allows you to select a single, fixed analysis range. It then allows you to redefine the upper and lower limits, for the range.

Press *Range* key to start the Range function.

```
Select range
mode:  MANUAL
```

If above screen displays, use the  $\Delta\nabla$  arrow keys to Select MANUAL, and press *Enter*.

```
Select range to run
-> 01  02  03  CAL<-
```

Use the <> keys to select the range: 01, 02, 03, or CAL. Then press *Enter*.

```
Gas use:  SO2
Range:   0 - 10 %
```

Use the <> keys to toggle between the Range: low-end field and the Range: high-end field. Use the  $\Delta\nabla$  keys to change the values of the fields.

Press *Escape* to return to the previous screen to select or define another range.

Press *Enter* to return the to the *Analyze* function.

### 3.6.2 Auto Screen

Autoranging will automatically set to the application that has at least two ranges setup with the same gases.

In the autoranging mode, the microprocessor automatically responds to concentration changes by switching ranges for optimum readout sensitivity. If the upper limit of the operating range is reached, the instrument automatically shifts to the next higher range. If the concentration falls to below 85% of full scale of the next lower range, the instrument switches to the lower range. A corresponding shift in the DC concentration output, and in the range ID outputs, will be noticed.

The autoranging feature can be overridden so that analog output stays on a fixed range regardless of the contaminant concentration detected. If the concentration exceeds the upper limit of the range, the DC output will saturate at 1 V dc (20 mA at the current output).

However, the digital readout and the RS-232 output of the concentration are unaffected by the fixed range. They continue to read beyond the full-scale setting until amplifier saturation is reached. Below amplifier saturation, the overrange readings are accurate UNLESS the application uses linearization over the selected range.

The concentration ranges can be redefined using the *Range* function Manual screen, and the application gases can be redefined using the *System* function, **if** they are not already defined as necessary.

**CAUTION: Redefining applications or ranges might require relinearization and/or recalibration.**

To setup automatic ranging:

Press *Range* key to start the Range function.

```
Select range  
mode : AUTO
```

If above screen displays, use the  $\Delta$  and  $\nabla$  arrow keys to Select AUTO, and press *Enter*.

Press *Escape* to return to the previous Analyze Function.

### 3.6.3 Precautions

The Model 6000B allows a great deal of flexibility in choosing ranges for automatic range switching. However, there are some pitfalls that are to be avoided.

Ranges that work well together are:

- Ranges that have the same lower limits but upper limits that differ by approximately an order of magnitude
- Ranges whose upper limits coincide with the lower limits of the next higher range
- Ranges where there is a gap between the upper limit of the range and the lower limit of the next higher range.

Range schemes that are to be avoided include:

- Ranges that overlap
- Ranges whose limits are entirely within the span of an adjoining range.
- Ranges where the zero is suppressed, is 1-10, 1-100, etc, however, 80-100, 90-100 is ok where the zero gas is actually 100% concentration and the calibration is inverted.

Figure 3-2 illustrates these schemes graphically.

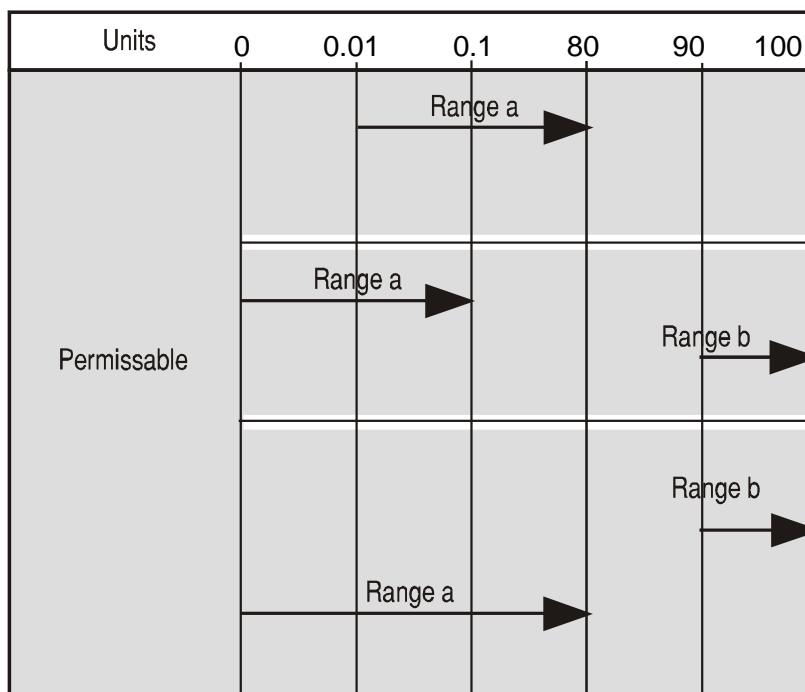

Figure 3-2: Examples of Autoranging Schemes

### 3.7 The *Analyze* Function

Normally, all of the functions automatically switch back to the *Analyze* function when they have completed their assigned operations. Pressing the *Escape* button in many cases also switches the analyzer back to the *Analyze* function. Alternatively, you can press the *Analyze* button at any time to return to analyzing your sample.

The *Analyze* function screen shows the impurity concentration and the application gases in the first line, and the range in the second line. In the lower right corner, the abbreviation Anlz indicates that the analyzer is in the *Analyze* mode. If there is an \* before the Anlz, it indicates that the range is linearized.

```
1.95 ppm SO2
R1:Ø -10 *Anlz
```

If the concentration detected is overrange, the first line of the display blinks continuously.

### 3.8 Programming

**CAUTION:** *The programming functions of the Set Range and Curve Algorithm screens are configured at the factory to the users application specification. These functions should only be reprogrammed by trained, qualified personnel.*

To program, you must:

1. Enter the password, if you are using the analyzer's password protection capability.
2. Connect a computer or computer terminal capable of sending an RS-232 signal to the analyzer RS-232 connector. (See chapter 2 *Installation* for details). Send the **rp** command to the analyzer.
3. Press the *System* button to start the *System* function.

```
DIG_FILT SELF-TEST
PWD   LOGOUT   MORE
```

Use the < > arrow keys to blink MORE, then press *Enter*.

```
AUTOCAL FILSOLL HOLD
CAL-HOLD-TIMER  MORE
```

Select MORE and press ENTER one more time

```
ALGORITHM          APPLICATION
MORE OUTPUT:      4MA
```

Now you will be able to select the APPLICATION and ALGORITHM set-up functions.

#### 3.8.1 The Set Range Screen

The Set Range screen allows reprogramming of the three analysis ranges and the calibration range (background gas, low end of range, high end of range, and % or ppm units). Original programming is usually done at the factory according to the customer's application. It must be done through the RS-232 port using a computer running a terminal emulation program.

**Note:** It is important to distinguish between this *System* programming subfunction and the *Range* button function, which is an operator control. The Set Range Screen of the *System* function allows the user to DEFINE the upper and lower limits of a range AND the application of the range. The *Range* button

**function only allows the user to select or define the limits, or to select the application, but not to define the application.**

Normally the Model 6000B is factory set to default to manual range selection, unless it is ordered as a single-application multiple-range unit (in which case it defaults to autoranging). In either case, autoranging or manual range selection can be programmed by the user.

In the autoranging mode, the microprocessor automatically responds to concentration changes by switching ranges for optimum readout sensitivity. If the upper limit of the operating range is reached, the instrument automatically shifts to the next higher range. If the concentration falls to below 85% of full scale of the next lower range, the instrument switches to the lower range. A corresponding shift in the DC concentration output, and in the range ID outputs, will be noticed.

The autoranging feature can be overridden so that analog output stays on a fixed range regardless of the contaminant concentration detected. If the concentration exceeds the upper limit of the range, the DC output will saturate at 1 V dc (20 mA at the current output).

However, the digital readout and the RS-232 output of the concentration are unaffected by the fixed range. They continue to read beyond the full-scale setting until amplifier saturation is reached. Below amplifier saturation, the overrange readings are accurate UNLESS the application uses linearization over the selected range.

To program the ranges, you must first perform the four steps indicated at the beginning of section 3.8 *Programming*. You will then be in the second *System* menu screen.

```
ALGORITHM      APPLICATION
MORE           OUTPUT: 4MA
```

Use the <> arrow keys again to move the blinking to APPLICATION and press *Enter*.

```
Sel rng to set appl:
-> 01 02 03 CAL <-
```

Use the  $\Delta$ / $\nabla$  arrow keys to increment/decrement the range number to 01, 02, 03, or CAL, and press *Enter*.

```
Gas Name      *****
FR:0   TO:10 %
```

Use the <> arrow keys to move to Gas Name, FR: (from—lower end of range), TO: (to—upper end of range), and PPM or %.

---

Use the  $\Delta\nabla$  arrow keys to increment the respective parameters as desired. Press *Enter* to accept the values and return to *Analyze* mode. (See note below.) Repeat for each range you want to set.

**Note: The ranges must be increasing from low to high, for example, if Range 1 is set to 0–10 % and Range 2 is set to 0–100 %, then Range 3 cannot be set to 0–50 % since that makes Range 3 lower than Range 2.**

Ranges, alarms, and spans are always set in either percent or ppm units, as selected by the operator, even though all concentration-data outputs change from ppm to percent when the concentration is above 9999 ppm.

**Note: When performing analysis on a fixed range, if the concentration rises above the upper limit as established by the operator for that particular range, the output saturates at 1 V dc (or 20 mA). However, the digital readout and the RS-232 output continue to read regardless of the analog output range.**

To end the session, send:

```
st<enter>  
st<enter>
```

to the analyzer from the computer.

### 3.8.2 The Curve Algorithm Screen

The Curve Algorithm is a linearization method. It provides from 1 to 9 intermediate points between the ZERO and SPAN values, which can be normalized during calibration, to ensure a straight-line input/output transfer function through the analyzer.

Each range is linearized individually, as necessary, since each range will usually have a totally different linearization requirement.

To linearize the ranges, you must first perform the four steps indicated at the beginning of section 3.8 *Programming*. You will then be in the second *System* menu screen.

#### 3.8.2.1 Manual Mode Linearization

To linearize manually, you must have previous knowledge of the nonlinear characteristics of your gases. You enter the value of the differential between the actual concentration and the apparent concentration (analyzer output). TAI has tabular data of this type for a large number of gases, which it makes available to customers on request. See Appendix for ordering information. To enter data:



From the *System* Functions Screen—

1. Use <> to select ALGORITHM , and *Enter*.
2. Select and *Enter* SETUP.
3. *Enter* MANUAL from the Calibration Mode Select screen.

```
Dpt  INPUT  OUTPUT
  0  0.00  0.00
```

The data entry screen resembles the verify screen, but the gas values can be modified and the data-point number cannot. Use the <> keys to toggle between the INPUT and OUTPUT fields. Use the  $\Delta \nabla$  keys to set the value for the lowest concentration into the first point. Then press *Enter*.

After each point is entered, the data-point number increments to the next point. Moving from the lowest to the highest concentration, use the  $\Delta \nabla$  keys to set the proper values at each point.

```
Dpt  INPUT  OUTPUT
  0  0.00  0.00
```

Repeat the above procedure for each of the data points you are setting (up to nine points: 0-8). Set the points in unit increments. Do not skip numbers. The linearizer will automatically adjust for the number of points entered.

When you are done, Press *ESCAPE*. The message, Completed. Wait for calculation, appears briefly, and then the main *System* screen returns.

To end the session, send:

```
st<enter>
st<enter>
```

to the analyzer from the computer.

### 3.8.2.2 Auto Mode Linearization

To linearize in the Auto Mode, you must have on hand a separate calibration gas for each of the data points you are going use in your linearization. First, the analyzer is zeroed and spanned as usual. Then, each special calibration gas, for each of the intermediate calibration points, is flowed, in turn, through the sensor. As each gas flows, the differential value for that intermediate calibration point is entered from the front panel of the analyzer.

**Note:** The span gas used to span the analyzer must be >90% of the range being analyzed.

---

Before starting linearization, perform a standard calibration. See section 4.4. To enter data:

From the *System* Functions screen—

1. Use < > to select ALGORITHM , and *Enter*.
2. Select and *Enter* SETUP.
3. *Enter* AUTO from the Calibration Mode Select screen.

The Auto Linearize Mode data entry screen appears.

```
19.5 ppm SO2
Input (x) :20.00
```

5. Use the  $\Delta \nabla$  keys to set the proper value of calibration gas, and *Enter*. Repeat this step for each cal-point number as it appears in the Input (x) parentheses.
6. Repeat step 5 for each of the special calibration gases, from the lowest to the highest concentrations. Press *Escape* when done.

To end the session, send:

```
st<enter>
```

```
st<enter>
```

to the analyzer from the computer.

---

## Maintenance

---



Aside from normal cleaning and checking for leaks at the gas connections, routine maintenance is limited to replacing filter elements and fuses, and recalibration.

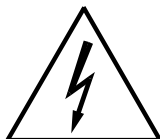

**WARNING:** SEE WARNINGS ON THE TITLE PAGE OF THIS MANUAL.

### 4.1 Fuse Replacement

The 6000B requires two 5 x 20 mm, 6.3 A, F type (Fast Blow) fuses.

The fuses are located inside the main housing on the Electrical Connector Panel, as shown in Figure 4-3. To replace a fuse:

1. Disconnect the Unit from its power source.
2. Place a small screwdriver in the notch in the fuse holder cap, push in, and rotate 1/4 turn. The cap will pop out a few millimeters. Pull out the fuse cap and fuse, as shown in Figure 4-1

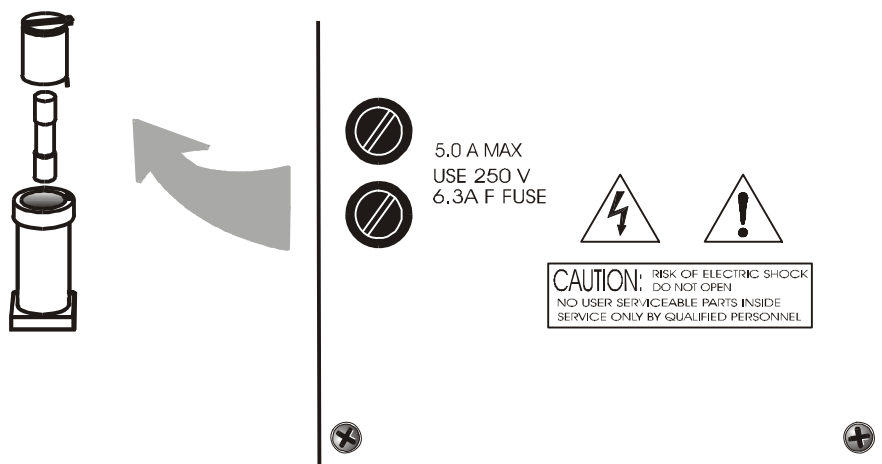

Figure 4-1: Removing Fuse Block Cap and Fuse from Housing

2. Replace fuse by reversing process in step 1.

## 4.2 System Self Diagnostic Test

1. Press the *System* button to enter the system mode.
2. Use the <> arrow keys to move to *More*, and press *Enter*.
3. Use the <> arrow keys to move to *Self-Test*, and press *Enter*.

The following failure codes apply:

**Table 4-1: Self Test Failure Codes**

### Power

0	OK
1	5 V Failure
2	15 V Failures
3	Both Failed

### Analog

0	OK
1	DAC A (0–1 V Concentration)
2	DAC B (0–1 V Range ID)
3	Both Failed

**Preamp**

- 0 OK
- 1 Zero too high
- 2 Amplifier output doesn't match test input
- 3 Both Failed
- >3 Call factory for information

**Cell**

- 0 OK
- 1 Failed (open filament, short to ground, no power.)
- 2 Unbalance (deterioration of filaments, blocked tube)

**4.3 Major Internal Components**

The major components in the Control Unit are shown in Figure 4-3.

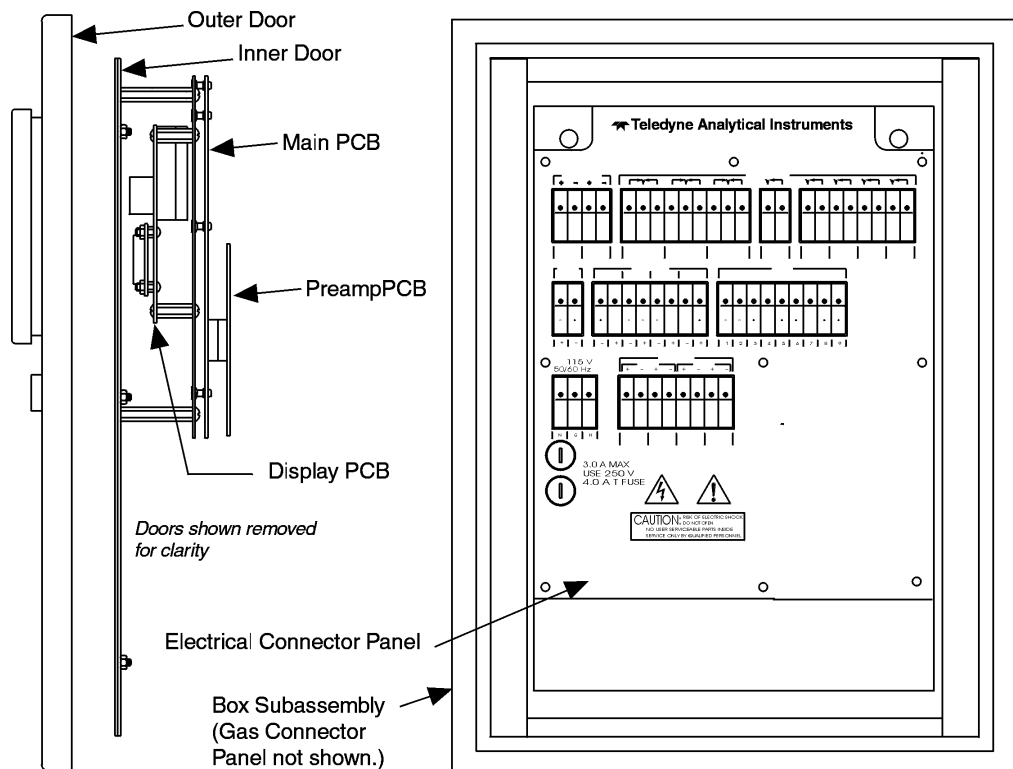

Figure 4-3: Control Unit Major Internal Components

**WARNING:** HAZARDOUS VOLTAGES EXIST ON CERTAIN COMPONENTS INTERNALLY WHICH MAY PERSIST FOR A TIME EVEN AFTER THE POWER IS TURNED OFF AND DISCONNECTED.



The 6000B Control Units contain the following major components:

- Power Supply
- Motherboard (with Microprocessor, RS-232 chip, and Preamplifier PCB)
- Front Panel Display Board and Displays—
  - 5 digit LED meter
  - 2 line, 20 character, alphanumeric, VFD display

**See the drawings in the Drawings section in back of this manual for details.**

---

OPERATING INSTRUCTIONS

# Model 6000B

*Photometric Analyzer*

## Part II: Analysis Unit

NEC Type

Part Number D-65478

**6000A - GP, Rack, Panel (Integral or Remote)**

**6000 - GP, Bulkhead (Z-Purged in Div II areas)  
(Integral or Remote)**

**6020 - (X-Proof, 1,1,B, C, D) (Integral or Remote)**

**Table of Contents**

---

**1 Operational Theory**

1.0 Introduction ..... 1-1  
1.1 Method of Analysis ..... 1-1  
1.2 Optical Bench ..... 1-2  
1.3 Photometer Amplifier ..... 1-3  
1.4 Automatic Zero System ..... 1-4  
1.5 System Description ..... 1-5  
1.6 Photometer ..... 1-6  
    1.6.1 Source Module ..... 1-6  
    1.6.2 Sample Cell ..... 1-7  
    1.6.3 Detector Module ..... 1-8  
1.7 Sample Systems ..... 1-6

**2 Installation**

2.1 Unpacking the Analyzer ..... 1-1  
2.2 Installing & Connecting the Analyzer ..... 1-1  
    2.2.1 User Connections ..... 3-1  
    2.2.2 Electrical Power Connections ..... 1-2  
    2.2.3 Compressed Air Supply ..... 2-2  
    2.2.4 Pipe Connections ..... 2-2  
    2.2.5 Signal and Alarm Output Connections ..... 2-2  
    2.2.6 Sample Delivery System ..... 2-2  
    2.2.7 Draining the System ..... 2-3  
2.3 Testing the System ..... 2-3  
2.4 Calibration ..... 2-3  
    2.4.1 Calibration Fluids ..... 2-3  
    2.4.2 Calibration ..... 2-3

**3 Maintenance**

3.0 Routine Maintenance ..... 3-1  
3.1 Automatic and Routine Operation ..... 3-1  
3.2 System Visual Check and Response Procedure ..... 3-1  
3.3 Routine Maintenance ..... 3-2  
3.4 Suggested Preventive Maintenance Schedule ..... 3-2



3.5	Service Procedures and Adjustments .....	3-3
3.5.1	Electronics .....	3-3
3.5.2	Power Supply Test Points .....	3-3
3.5.3	Setup of the Signal Processing Front-End Amplifier ..	3-4
3.5.4	Oscilloscope Display of the I to E Converter Output ..	3-4
3.5.5	Balancing the Optics for Equal Light Transmission with Zero Fluid in the Sample Cell .....	3-5
3.5.6	Setup of the Logarithmic Amplifier .....	3-6
3.5.7	Inverting Amplifier .....	3-6
3.5.8	Integrated Reference and Measuring Signals .....	3-7
3.5.9	Battery-Powered Oscilloscope Synchronization Point	3-7
3.6	Interface Board Terminal Strip .....	3-7

**Appendix**

A-1	Specifications .....	A-1
A-2	Recommended 2-Year Spare Parts List .....	A-3
A-3	Drawing List .....	A-4



## **Operational Theory**

---

### **1.0 Introduction**

The Teledyne Photometric Analyzer uses the ultraviolet (UV) absorption principle to detect and continuously measure a component of interest in a sample stream. The analyzer consists of a single sample cell, chopped beam, dual-wavelength UV process photometer and associated microprocessor based control unit and electronics.

### **1.1 Method of Analysis**

The following description shows the course of optical energy in the analyzer. The optical energy is emitted from a source lamp in the source module, passed through the sample cell, and received by the sensor, which converts the optical energy to pulses of electrical energy. These pulses of electrical energy are processed further in the detector module.

The result is separate pulses that are compared in the control unit to reveal the measurable difference between optical absorption of the sample at a selected wavelength (determined by the measuring optical filter) and a zero-absorption condition (set by the reference optical filter). The magnitude of that difference represents the concentration of the component of interest in the sample.

## 1.2 Optical Bench

Depending on the application, the analyzer comes with one of the following types of lamps: Deuterium (D), Quartz Iodine (L), or Mercury (Hg). Energy from the lamp, used as a source, is focused through a sample cell onto a photo detector. In front of the detector is a motor-driven filter disc containing two optical filters mounted 180 degrees apart that alternately and continuously rotate into and out of the light beam. Sample flows continuously through the sample cell and absorbs optical energy at various wavelengths depending on its composition.

The analyzer monitors two wavelengths: a measuring wavelength selected where the component of interest has a characteristic absorption peak and a reference wavelength that provides stability by compensating for extraneous phenomena such as turbidity, cell window deposits, unequal optical component aging, etc.

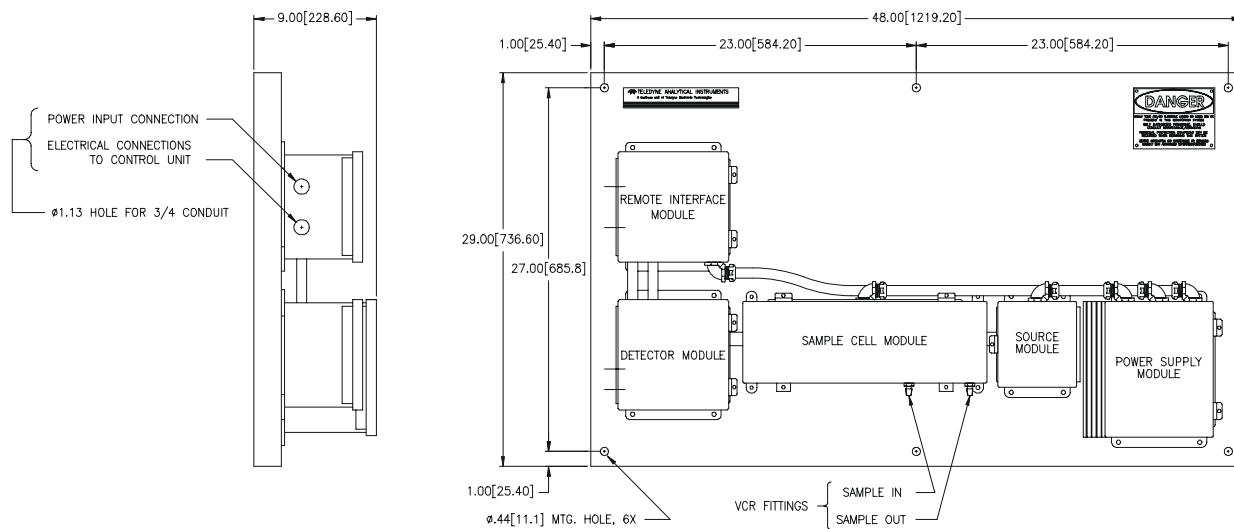

Shown without an Integral General Purpose Control Unit

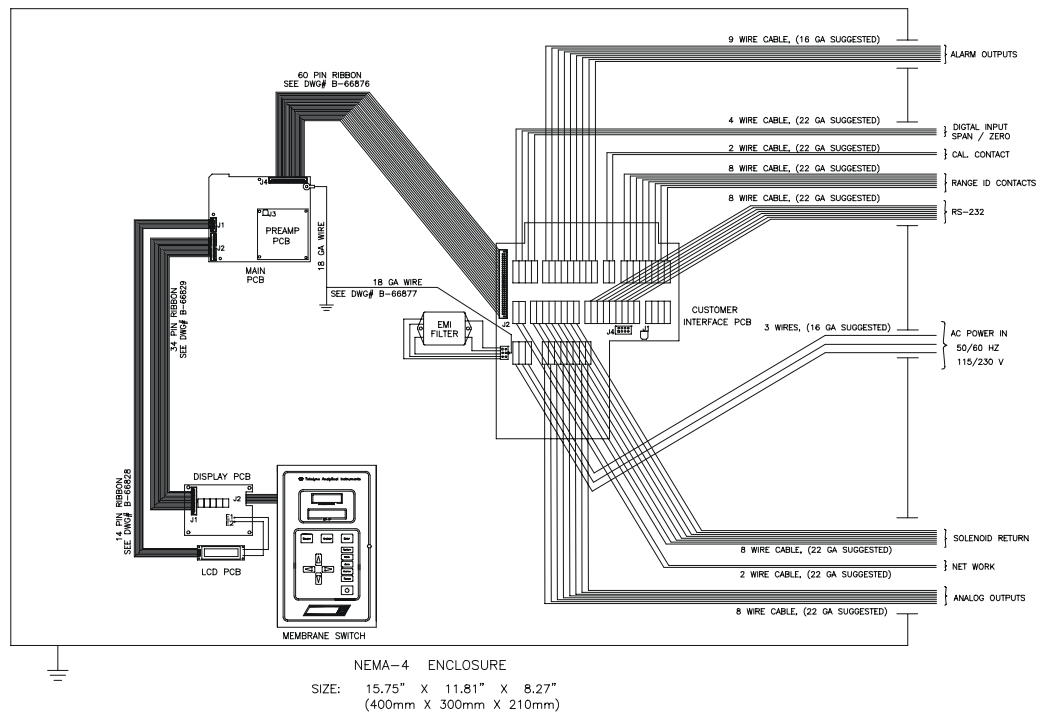
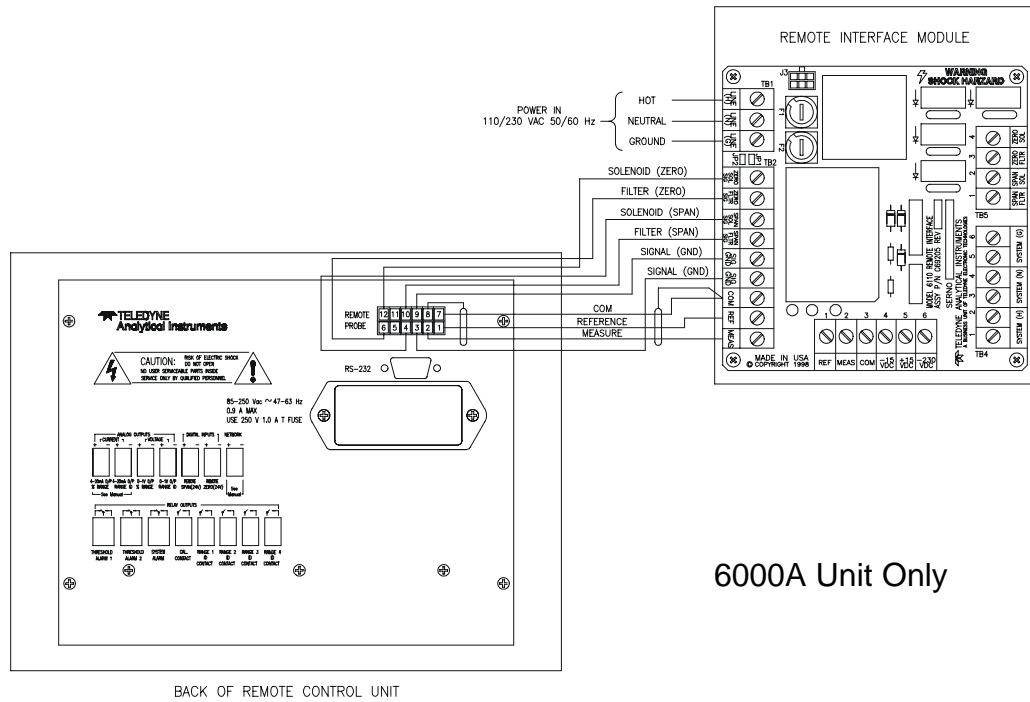

D-69023

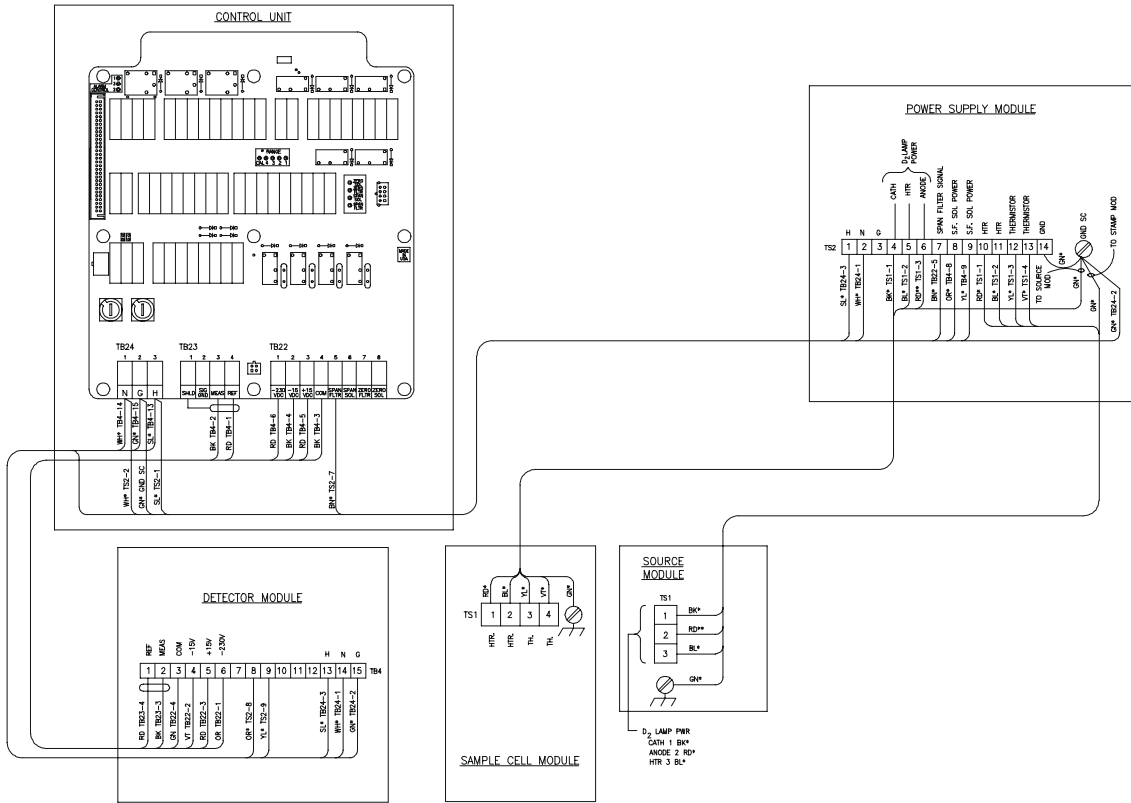
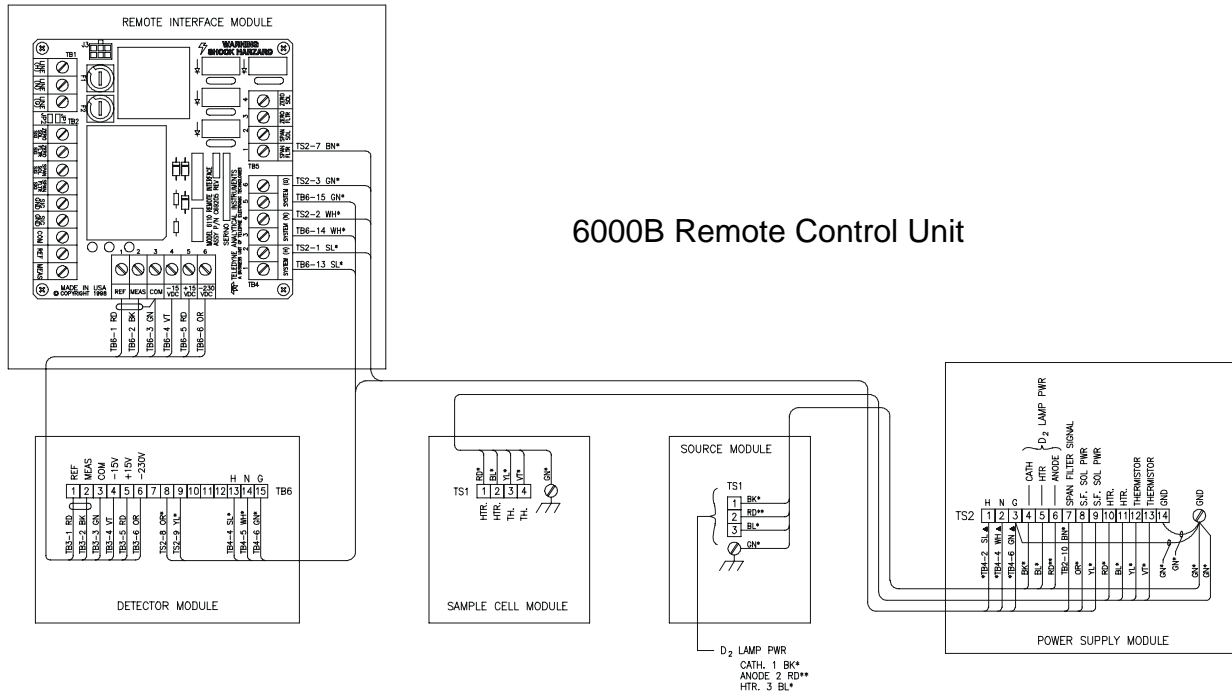

6000B Integral Control Unit

### 1.3 Photometer Amplifier

The photo detector converts the photo energy striking it to electrical energy. The magnitude of the photo energy pulses that strike the detector is determined by absorbance by the sample and the properties of the optical filters.

The detector output, which is a sequence of pulses that directly reflect the photo energy transmitted by the measuring and reference filter, is a measure of the concentration of the component of interest in the sample. The difference in energy between the measuring and reference pulse is related exponentially to the concentration of the component of interest.

The photo detector current output is amplified by a current to voltage (I to E) converting amplifier, followed by a second amplifier. The gain of the amplifier can be adjusted to obtain any desired output level.

To obtain analyzer outputs that are linearly related to the concentration of the component of interest, the output of the I to E converting amplifier is fed to the input of a logarithmic amplifier, which produces a signal that represents the logarithm of the output signal of the second amplifier. The output of the logarithmic amplifier is fed to the input of an inverting amplifier, which acts like a buffer between log amplifier and switch and inverts the input signal for further processing.

The output of the inverting amplifier is fed to a magnetically activated SPDT reed switch, synchronized in such a way that all measuring pulses are collected on one switch contact and all reference pulses on the other.

The pulses pass through diodes that isolate the integrating networks from each other. The integrators convert the reference and measuring pulse energy to a DC level representing them. These reference and measuring DC levels are applied to the subtracting amplifier in the Control Unit. The output of the subtractor is a DC voltage linearly related to the concentration of the component of interest.

From the subtractor, the signal progresses to the analog to digital converter on the motherboard of the Control Unit.

The microcontroller reads the A to D converter and displays the result on the front panel.

The procedure to set up the optical bench, the signal processing front-end amplifiers, the standardization of outputs, and alarm systems are described in separate sections of the manual.

## 1.4 Automatic Zero System

To compensate for zero drift, which may occur during sampling, the analyzer zero reading is updated by the Auto-Cal function of the controller. An electronics timing circuit provides a timing cycle that is user programmable.

The Auto-Zero system is turned off (see chapter 3 section 5). You have the option of setting the analyzer for one six minute zero cycle during hourly intervals of time from one to 23 hours, and daily from one to 30 days.

The Auto Zero system compares the present zero reading of the zero fluid with the zero reading of the zero fluid as it was in the last zero calibration. When there is a difference, the electronic zero circuit sets the zero reading to what it was in the last scheduled zero calibration. This zero reading is set at zero. The Auto Zero circuit is a digital circuit, which employs a DAC (Digital to Analog Converter) that can go out of range.

When the threshold cannot be found (oscillation persists), this means that measuring and reference peak signals as viewed on the oscilloscope at the output of the second amplifier in the detector module are too far out of balance on zero fluid. When this occurs, you must initiate optical balancing of the optical filters for equal light transmission on zero fluid. Measuring and reference peaks must be within one volt with zero fluid in the cell.

### **Zero drift may occur in the following cases:**

1. The output source changes or chemical or solid deposits form on the cell windows, but the application is such that interfering chemicals (sample background changes) are not a problem. The zero fluid in this case may be the major component of the sample, void of the component of interest.

2. The sample may contain chemicals that are not of interest, but absorb UV energy at the measuring wavelength used for analysis of the component of interest. These chemicals produce a signal that adds to the signal of the component of interest and makes it inaccurate. The Auto Zero system discriminates the two signals and drives the interfering signal of the



background chemicals below zero on an hourly basis. The zero fluid in this case is the sample of which the component of interest is filtered out while the background chemicals are preserved. The Auto Zero system corrects for background changes on an hourly basis, if the analyzer is set to Auto-Zero in an hourly basis.

## 1.5 System Description

The photometric analyzer is generally constructed for general-purpose (Model 6000B) use and is mounted on a BACKPLATE, an open rack, or in a closed cubicle.

## 1.6 Photometer

The three photometer modules are mounted on a BACKPLATE. Facing the mounted photometer, the source module is at the right, the sample module is in the center, and the detector module is on the left. Figure 6 shows a diagram of the modules. A source power supply module is placed near the source module. Modules for the general-purpose units (Model 6000) are constructed of sheet metal.

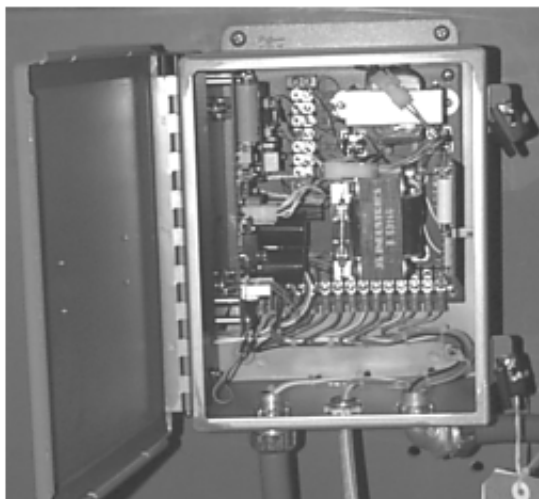

Source Power Supply and optional Temperature Controller PCB

### 1.6.1 Source Module

Any one of three types of source modules may be used in your system. The system model designation identifies the source lamp (see Figure 1 for a list of codes).

The QI (Quartz-Iodine) and D<sub>2</sub> (Deuterium Arc) sources are mounted in the source module which also contains the focusing lens.

The source power supply module provides power to the lamps. The source power supply module houses the power supply, a connector for an optional temperature controller to heat the sample cell, and an optional span filter power supply.

The Quartz-Iodine lamp power supply is a switching regulator that maintains a constant voltage (5 VDC) across the filament of the lamp. The lamp is incandescent. Its envelope is filled with a halogen to avoid sputtering of the filament, blackening the lamp envelope.

The D<sub>2</sub> lamp power supply is a combination current and voltage regulator. It maintains a constant anode current in the D<sub>2</sub> lamp and controls the voltage across the lamp's cathode (filament).

When power is turned on, relay K1 is activated and applies 10 VDC across the filaments. After ionization of the Deuterium vapor, the lamp starts to conduct from cathode (filament) to anode. This causes K1 to deactivate and the filament voltage drops to 7 VDC, which is the operating voltage. The voltage from anode to cathode which was 365 V before ionization, drops to about 60 VDC after ignition. This is the operating voltage. A constant current of 350 mADC is the anode current.

The Deuterium arc lamp is employed with samples whose component of interest does not absorb at the high intensity peaks of the HG source emission spectrum. The Deuterium arc produces a broadband of energy (200 to 400 nanometer) in the UV spectrum.

The HG (Mercury arc) source and its power supply reside in one enclosure. A quartz lens focuses the energy into a beam for transmission.

**WARNING: UNDER NO CIRCUMSTANCES SHOULD THE SOURCE MODULE BE OPEN AND THE LAMP ALLOWED TO OPERATE UNLESS PERSONNEL IN THE IMMEDIATE VICINITY ARE WEARING UV FILTERING EYE GOGGLES.**



### 1.6.2 Sample Cell

The sample cell rests in a module placed between the source and detector module. The module contains the sample cell and optional heater and thermistor for temperature-controlled sample cells.

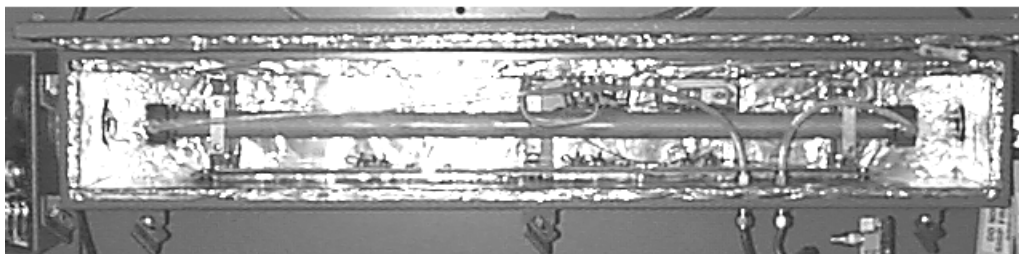

Exposed Sample Module

### 1.6.3 Detector Module

The detector module houses the photo detector, chopper assembly, and the signal processing stages of the electronics circuitry. The synchronized chopper motor rotates at 1800 rpm. The detector type found in your analyzer can be identified from the letter in the model number (either B or P).

The filter wheel that carries the optical filters is marked with (M) for measuring and R for reference filter. If you remove the filter wheel, you must align a reference mark on the wheel with a reference mark on the shaft. When the switch activating disc is removed, align with the marks on the switch plate and motor mount when you put it back.

The phototube detector PC board contains the I to E converter stage, second amplifier, logarithmic amplifier, inverter, and first stage of integration. The solid state detector has its I to E converter stage built in on the detector PC board. A system with a solid state detector has a second converter PC board containing the second amplifier, logarithmic amplifier, inverter, and first stage of integration.

The magnetically-activated reed switch is mounted on the motor mount. Oscilloscope test points are available and are mounted on a bracket inside the housing for explosion-proof models; test points are available on the outside in the bottom for general-purpose units. An optional zero and/or span filter is located in this module also.

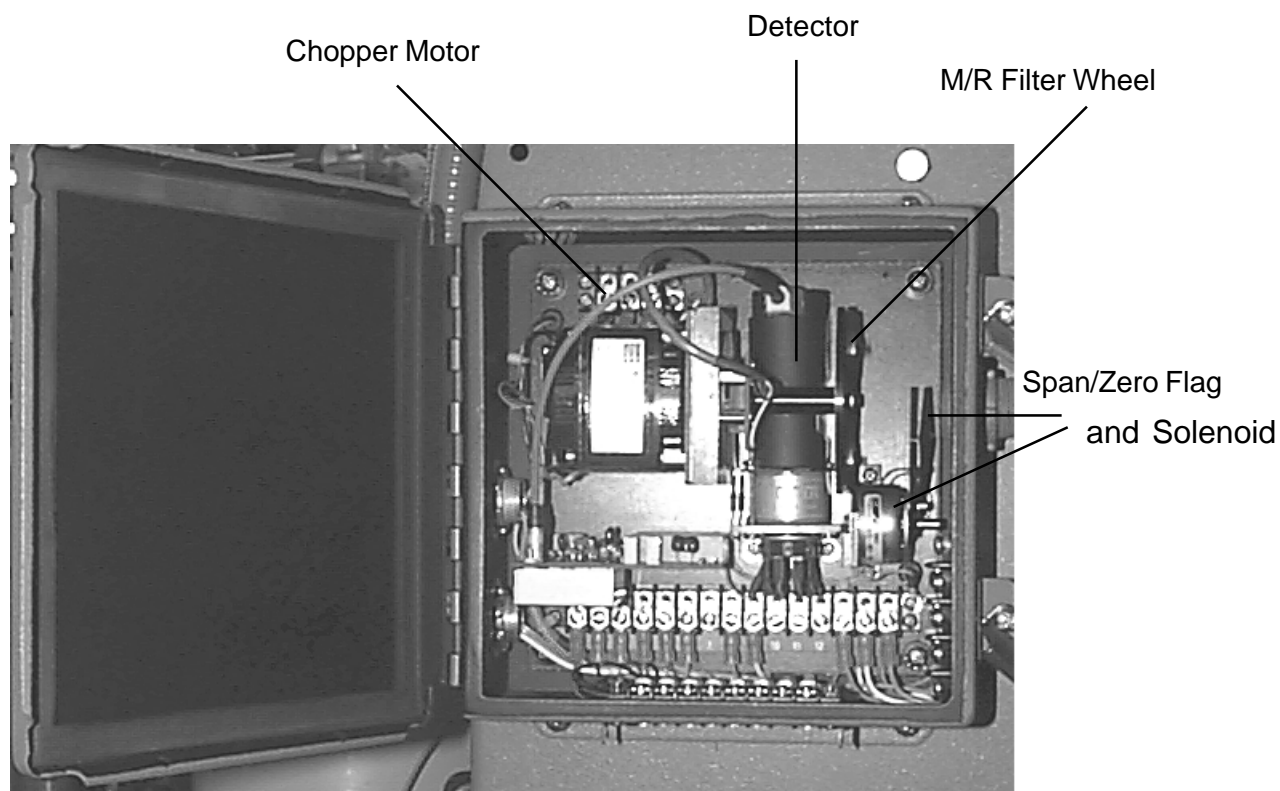

Photodetector and Preamplifier PCB

### 1.7 Sample Systems

Below are sample systems that deliver gases to the 6000/6020 sample cell of the Analysis Unit. Depending on the mode of operation either sample or calibration gas is delivered.

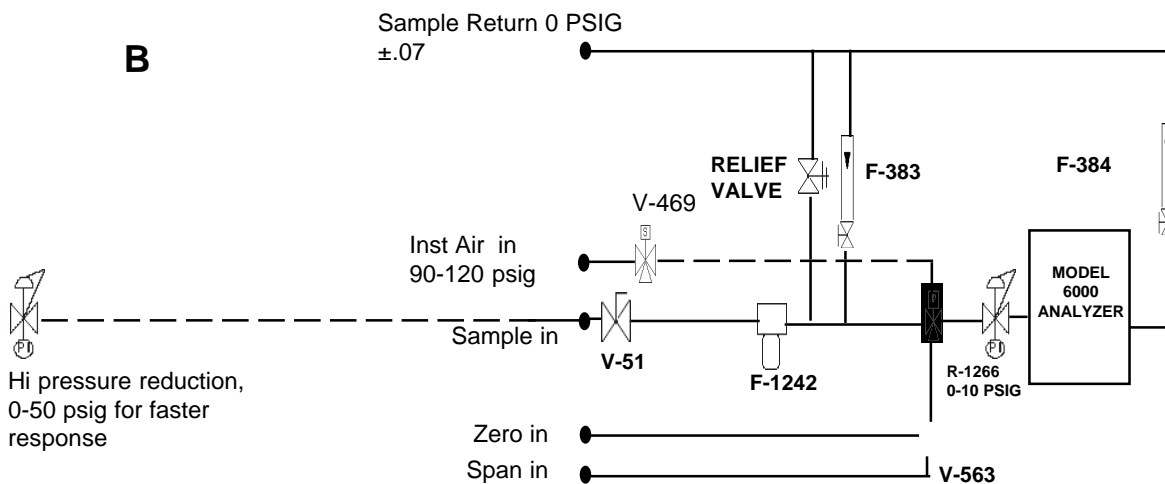
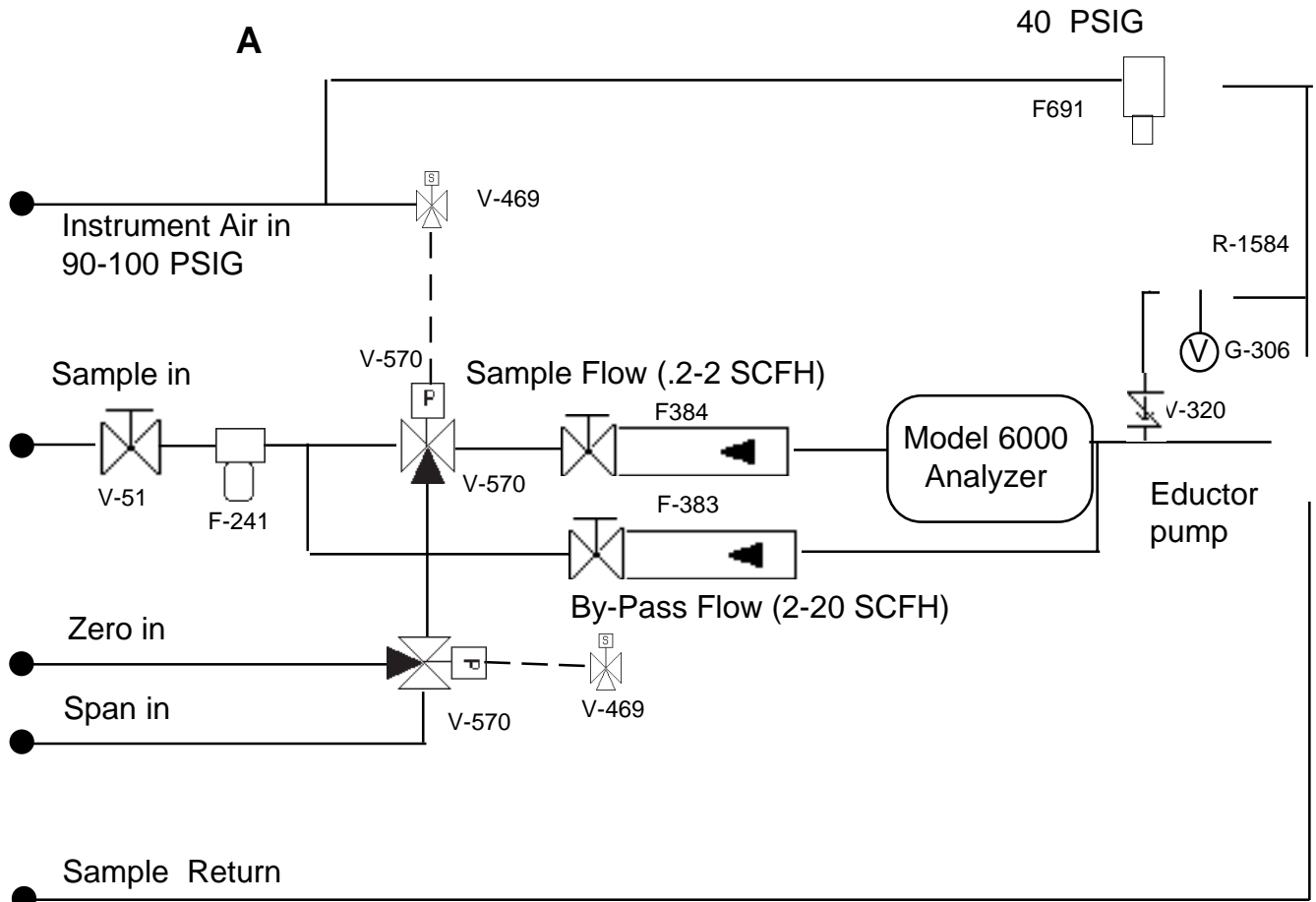

C

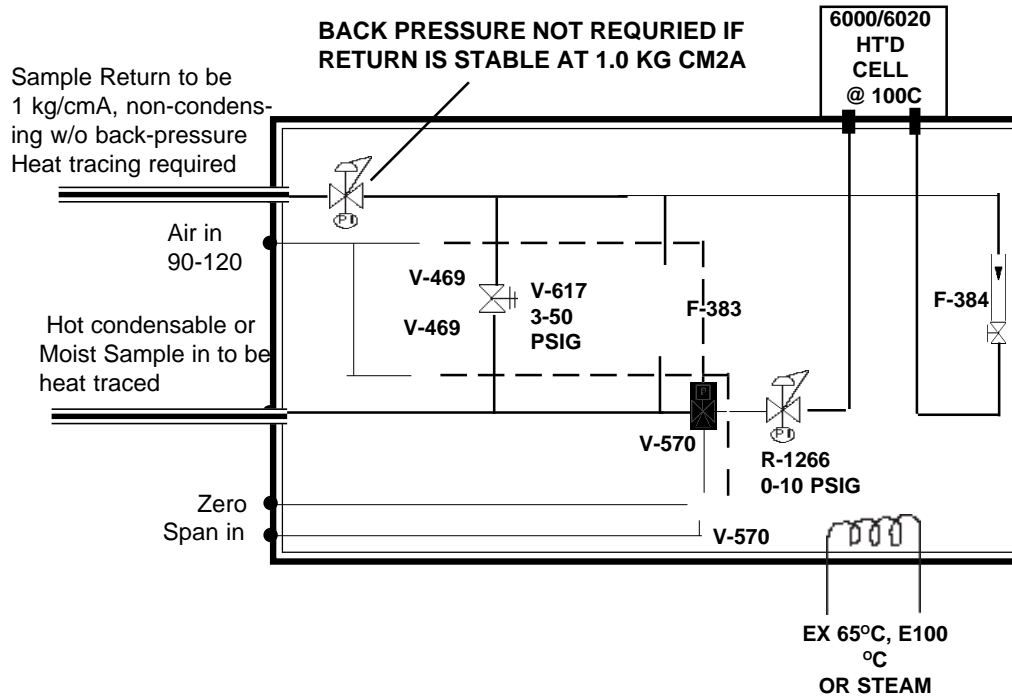

D

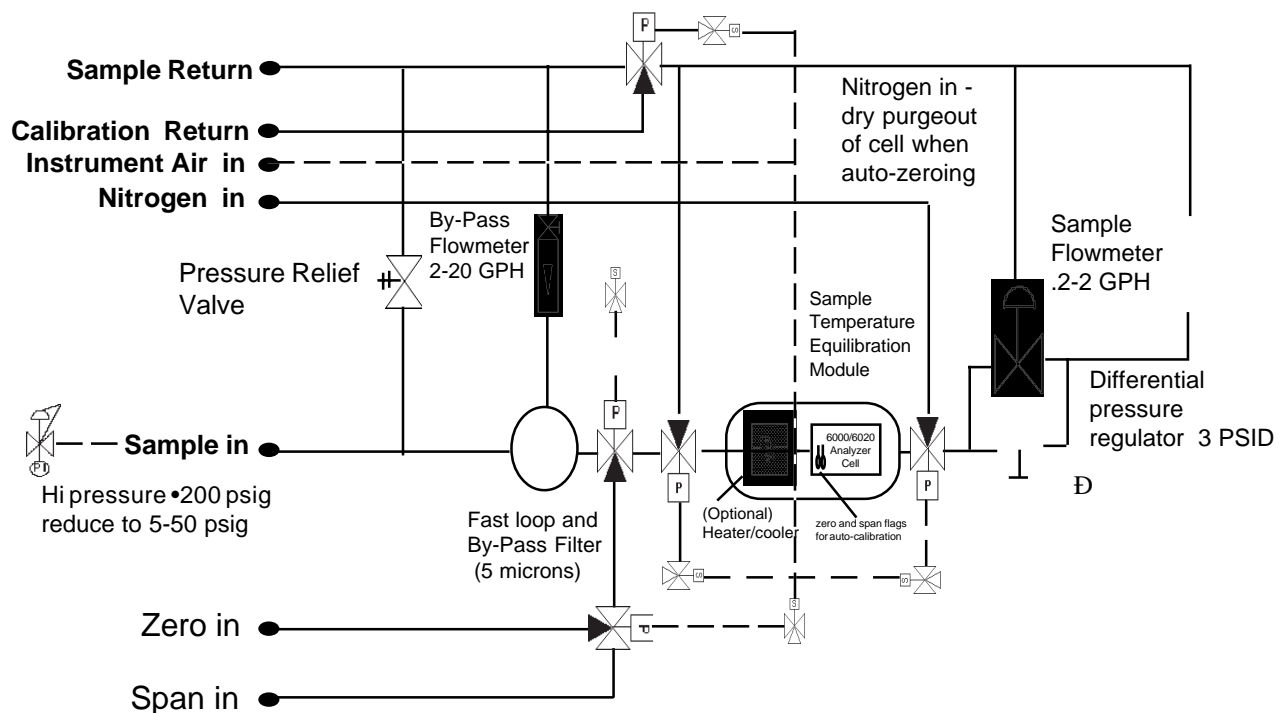

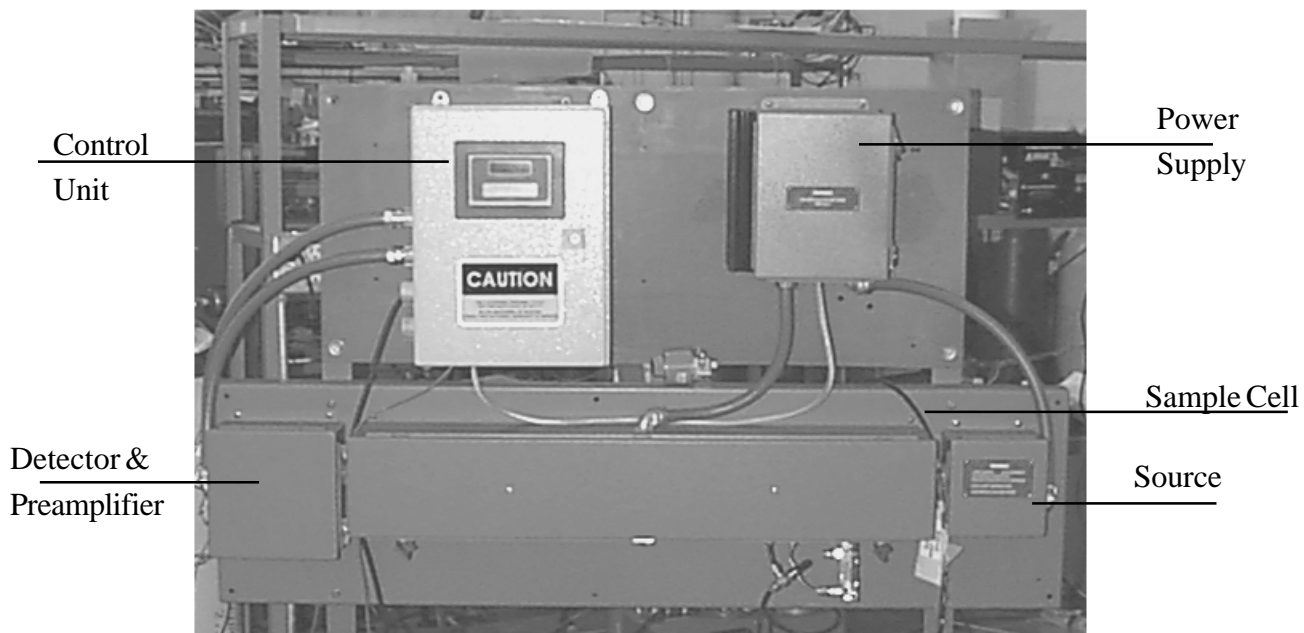

Model 6000B Photometric Analyzer with D2 Lamp  
Analysis Bench shown with Integral General purpose bulkhead  
Control Unit



Model 6000B Photometric Analyzer with D2 Lamp





## **Installation**

---

Installation of the Model 6000 Photometric Analyzer includes:

1. Unpacking
2. Mounting
3. Gas connections
4. Electrical connections
5. Testing the system.

### **2.1 Unpacking the Analyzer**

The analyzer is shipped with all the materials you need to install and prepare the system for operation. Carefully unpack the analyzer and inspect it for damage. Immediately report any damage to the shipping agent.

### **2.2 Installing and Connecting the Analyzer**

Without Temperature Control, the system must be installed in an area where the ambient temperature is not permitted to drop below 32°F nor rise above 110°F.

Regardless of configuration, the system must be installed on a level surface with sufficient space allocated on either side for personnel and test equipment access. Subject to the foregoing, the system should be placed as close to the sample point as possible and bolted to its supporting surface. A waterproof mastic should be liberally applied to the under surfaces of all four supporting legs of the cubicle system before placing it in position and bolting it in place.

#### **2.2.1 User Connections**

All user connections are around the periphery of the equipment panel (or cubicle) and appear in the outline diagram in the back of the manual.

---

### 2.2.2 Electrical Power Connections

The system requires a supply of 115 VAC, single-phase power. Power connections are made inside the control unit. Refer to the input-output diagram for more information. The electrical power service must include a high-quality ground wire. A high-quality ground wire is a wire that has zero potential difference when measured to the power line neutral.

### 2.2.3 Compressed Air Supply

The system may require a supply of air to drive pneumatically activated valves or for use as zero gas. In general, a 2 liter/minute supply of compressed air at a maximum of 150 psig is usually sufficient. The air supply must have far greater capacity when purging of the system or ejectors are used (special systems).

### 2.2.4 Pipe Connections

Refer to Appendix Piping Drawings for information about pipe connections. On special systems, consult the text in the manual that describes your particular sample system in detail.

### 2.2.5 Signal and Alarm Output Connections

Signal and alarm output connections are made inside the control unit to terminal blocks mounted on the interface PC board.

**Note: For current outputs, the signal circuit resistance, including accessory devices, must not exceed 1000 ohms. The alarm contact circuit must not draw more than 3 amperes at 115 VAC (non-inductive) or 30 VDC. Refer to the following section.**

### 2.2.6 Sample Delivery System

The sample delivery system should be designed to operate reliably and must be of large enough capacity to avoid flow stops or bubbles in liquid samples. A pump is required only if there is insufficient pressure to reliably supply the sample to the system equipment panel. Do not complicate the delivery system by adding a pump unless it is absolutely necessary. If a pump is required, select a type that can handle the sample (corrosion), as well as meet the area classification and Environmental conditions.

### 2.2.7 Draining the System

In liquid analysis systems, the system drain manifold must terminate in a safe area as the sample may be poisonous or corrosive.

## 2.3 Testing the System

Before plugging the instrument into the power source:

- Check the integrity and accuracy of the fluid connections. Make sure there are no leaks.
- Check the integrity and accuracy of the electrical connections. Make sure there are no exposed conductors
- Check that sample pressure is between 3 and 40 psig, according to the requirements of your process.

Power up the system, and test it by performing the following operations:

1. Repeat the Self-Diagnostic Test.

## 2.4 Calibration

### 2.4.1 Calibration Fluids

Zero and span fluids must be made by the chemistry lab or certified zero and span gas bought from a gas supplier. The zero fluid must be the major component of the sample, free from the component of interest.

The span fluid must be the major component of the sample mixed with a small amount of the component of interest. The concentration must be 80 to 95% of the range or the widest range of the instrument (if the instrument provides more than one range).

### 2.4.2 Calibration

Refer to Section 3.3.8 section I of the manual to determine how to manipulate the mode setting. Two calibration methods are available.

1. Calibration with zero and span fluids.

2. Calibration with a span filter (this method is available only if you select a span filter option when you purchase the equipment).

***Method One:***

1. Inject zero fluid and set zero as referred in section 3.4 section I
2. Inject span fluid and set the concentration of the span fluid with the span procedure referred in section 3.4 section I

***Method Two:***

1. Determine the span setting using Method One.
2. Activate the span filter (as referred in section 3.3.8) section I
3. Record the display reading (this is the span filter reading and must be recorded).
4. You can calibrate the instrument now with the span filter.

Power up the system, and test it as follows:

1. Repeat the Self-Diagnostic Test.

---

## Maintenance

---

### 3.0 Routine Maintenance



#### 3.1 Automatic operation and routine operational duties



The system operates continuously without adjustment. Under normal conditions, after you program the system for automatic operation, only routine maintenance procedures are necessary. The most common failure condition is a temporary interruption of the power serving the instrument. If the power service is interrupted, the source lamp in the analyzer will restart automatically as long as there is no defect in the lamp circuit or its starter.

You can detect a lamp off condition with the signal failure alarm circuit, but you must connect the relay contacts from the alarm to your indicating device. In addition, you will experience an alarm condition when the cell windows are extremely dirty or the electronics fail in the detector-converter, log amplifier, or inverter circuits. When the alarm circuit is powered independently from the analyzer power source, the alarm circuit is fail-safe and will detect power failure.

A message such as **"Cell Fail check the detector signal"** might be displayed if 1 amp off condition occurs

#### 3.2 System Visual Check and Response Procedure

1. Verify that the signal failure alarm is not in failure condition.
2. Verify that the zero and span control setting have not been disturbed.

3. Verify that the chart recorder contains a normal display.
4. Verify that the recorder has a sufficient supply of chart paper and ink.

### 3.3 Routine Maintenance

Keep the sample lines and components, including the measuring cell within the analyzer sample module, free of deposits and leaks. You must determine the interval between cleaning procedures empirically, because the duration of time that the system runs without attention is related directly to the sample's condition.

### 3.4 Suggested Preventive Maintenance Schedule

#### DAILY

1. Visually inspect the complete system for obvious defects, such as leaking tubes or connectors.
2. Verify that the sample pump (if applicable) is running.
3. Verify that the signal failure alarm is not in failure condition.
4. Verify that zero and span settings are correct.

#### WEEKLY

1. Examine sample cell windows for accumulation of solids. Remove and clean as necessary.
2. Calibrate the system.

#### ANNUALLY

1. Check the electronics calibration.

2. Check the UV source.

**NOTE:** *Be sure to wear UV filtering eye goggles.*

3. Check the solenoid valves.

### 3.5 Service Procedures and Adjustments

#### 3.5.1 Electronics

TAI aligns the system's electronics. However, you may need to touch up the circuitry, using the following procedure.

##### ***Equipment Required:***

Oscilloscope (dual trace is preferred, but not required) To observe oscilloscope test points switch the vertical input selector of the scope to DC.

Switch to AC to observe the demodulator switch signals.

DVM (Digital Voltmeter)

PC Board Extender

Use the PC board extender whenever you need to adjust trimpot. Because all PC board connectors are keyed to avoid wrong positioning in the connectors, you must remove the key and after testing you need to replace the key with long-nosed pliers. Turn off the power during this operation. Never disconnect or connect the PC boards with the power on, because you may damage the PC board C-MOS devices.

#### 3.5.2 Power Supply Test Points

Measure +15 volt  $\pm$ 1 volt DC and -15 volt  $\pm$ 1 volt DC on the differential power supply PC board in the control unit. Refer to the power supply schematic in the back of the manual to identify the power supply test points.

### 3.5.3 Setup of the Signal Processing Front-End Amplifiers

Fill the sample cell with air or a stable fluid, such that the photo energy that strikes the detector is constant. A stable fluid is distilled or tap water. This step may be omitted when the system is stable in its present state.

If you open the detector module, keep stray light out by covering the opening with a dense black cloth. If you do not take this precaution, the result is a misinterpretation of the scope patterns. On general-purpose systems, the scope test points are in the bottom of the detector module and are accessible without opening the module.

### 3.5.4 Oscilloscope Display of the I to E Converter Output

The output of the I to E Converter is observed at the output of the second amplifier. The objective of this operation is to set up the optical system and the gain of the second amplifier in such a way that the analyzer keeps operating within its dynamic range.

Connect the oscilloscope to TP3. The oscilloscope displays the measuring and reference pulses in an alternating pattern. The display is created by the light passing through the reference and measuring filters as they are brought in and out of the light beam by the rotating filter wheel. These light pulses are converted to electronic energy which is amplified and brought to TP2. The base line represents the blocking of the light beam by the opaque part of the filter wheel.

To identify which of the pulses is the measuring peak, insert the span filter (when present) or a piece of flat glass or clear plastic in the light beam. The peak that becomes the shortest (retracts excessively) is the measuring filter pulse.

In case you cannot set the gain properly, because the peaks are too short, too tall, or too much out of balance, adjust R2 trimpot on the converter PC board until you obtain the desired peak height as observed on the scope (usually 8 to 9 volt) for the tallest of the two peaks. Never leave the system operating with peaks exceeding 10 volts or you may saturate the logarithmic amplifier. You should not permit oscillations or distortions in the peaks.



---

### 3.5.5 Balancing the Optics for Equal Light Transmission with Zero Fluid in the SAMPLE CELL

The objective of this procedure is to obtain measuring and reference peak heights as displayed on the oscilloscope that are approximately equal, with the tallest peaks set at 8 to 9 volts. This must be done with air or zero fluid in the cell.

The procedure is purely mechanical and consists of adjusting the amount of light passing through either the measuring or reference filter, never both. Screens (wire mesh) of varying density are used for this operation and are part of the small tool kit accompanying the instrument.

1. Observe the oscilloscope and judge if optical balancing is needed. When the difference is less than 1 volt, balancing is not required. The tallest of the two peaks should be adjusted to 8 or 9 volts with the gain control R2 on the detector PC board. When this cannot be done because both peaks are too short or too long, search for screens mounted in the light path, usually located in a holder on the light pipe which interconnects the detector and sample module, and remove or add screens, as necessary.
2. When balancing is needed, identify the peaks as outlined under Section
3. For example, if the reference peak is the shorter one, stop the filter wheel with your hand and see if screens are located behind the reference filter. The reference filter is identified by the letter "R" engraved on the filter wheel.
4. If screens are found, remove them after taking the filter wheel off the shaft with the special Allen wrench supplied in the tool kit.
5. After removal of the screens and remounting the filter, mount the filter wheel back on the shaft. Position it correctly on the shaft by lining up the two paint marks on shaft and wheel.
6. Turn on the instrument and observe the balance on the oscilloscope.
  - a. If the reference peak is now too tall, remove the filter wheel and add a screen of lesser density behind the reference filter. Repeat this procedure until the peaks are within 1 volt of each other.

b. If the measuring peak is equal to or within 1 volt of the reference peak, the system is optically balanced and ready for calibration.

c. If the peak is still too short, repeat the procedure, but this time put a screen behind the measuring filter to shorten its peak.

7. After the peaks are balanced, adjust the gain control until the tallest of the two peaks is 8 to 9 volts. The peaks should still be within 1 volt of each other.

8. It is always good practice to operate the analyzer with as low a gain as possible. Therefore, with the gain control just barely off its stop, once again remove or add screens in the light path to obtain as high a voltage as possible without exceeding 9 volts for the highest peak. Read-just gain for 8 to 9 volts.

This concludes the balancing procedure and the instrument is ready for calibration.

### 3.5.6 Setup of the Logarithmic Amplifier

The amplifier is inverting and continuously taking the logarithm of the output signal of the second amplifier. You can observe the output by connecting the scope probe to TP4.

The correct wave shape has a rounded negative going pulse that is the signal and a flat-topped positive pulse that depicts saturation of the log amplifier.

*You should not permit distortions or oscillations in the rounded peaks.*

When the positive going pulse is not flat or is distorted, adjust trimpot R3 only enough to obtain a flat positive pulse. If you over adjust, you may lose part of the second decade of absorption and affect the accuracy of analysis for high concentrations of the component of interest where the measuring pulse can become very short. The log amplifier saturates because the amplifier is incapable of taking the logarithm of the slightly negative baseline.

### 3.5.7 Inverting Amplifier

The amplifier is inverting and has a gain of 1. It inverts the output signal of the logarithmic amplifier and acts as a buffer between the logarithmic amplifier and the reed switch and integrators. To observe the output of the inverter, connect the scope probe to TP5. The wave must be a duplicate of that observed on TP4, except that it is inverted.

---

### 3.5.8 Integrated Reference and Measuring Signals

You can observe the reference and measuring signal at the first stage of integration by connecting the scope probe to TP6 (reference signal) and TP7 (measuring signal) at the detector unit. A dual trace scope is advantageous but not required for this observation.

The test points' significance is that they reveal proper switch action. The display shows a sawtooth pattern that is a charge-discharge of the first capacitor in the integrating network. This ripple is the AC component of the reference and measuring signal after the pulses are converted to DC. The sawtooth patterns must be displayed 180° with respect to each other as viewed with a dual trace scope. They must both be present.

If one is missing, the switch is not switching. If the sawtooth shows a broken pattern, the switching action is feeble or irregular. Usually, you can fix the faulty condition of the switch by slightly changing the switch position.

The action of a bar magnet and a rotating chopper disc activate the magnetic mercury reed switch. An aluminum motor mounting block houses a bar magnet. This bar magnet is parallel with the mercury chopper switch.

The chopper disc is a green and black disc mounted on the filter wheel shaft next to the motor. The disc is composed of both magnetic and non-magnetic materials. As the shaft rotates, the magnetic portion of the disc shorts the magnetic flux as it passes between the magnet and the switch. The non-magnetic portion of the disc enables flux lines from the bar magnet to activate the mercury switch.

### 3.5.9 Battery-Powered Oscilloscope Synchronization Point

Because the line frequency cannot synchronize battery-powered oscilloscopes, use TP8 at the detector module to provide external synchronization.

## 3.6 Interface Board Terminals Strip

At the bottom of the interface PCB on the Control Unit, are three terminal strip where wiring is distributed to other sections of the Model 6000B System. Such as AC power for the D2 lamp power supply, DC Power to the preamplifier, High DC voltage for the photodetector, and signals to control calibration solenoids and filters. To gain access to this

terminals, the silkscreen cover must be removed. These terminals are wired in the factory.

**WARNING: DANGEROUS HIGH VOLTAGES ARE PRESENT AT THESE TERMINALS. TRAINED PERSONNEL MUST REMOVE THE SILKSCREEN COVER ONLY. EXERCISE EXTREME CAUTION.**

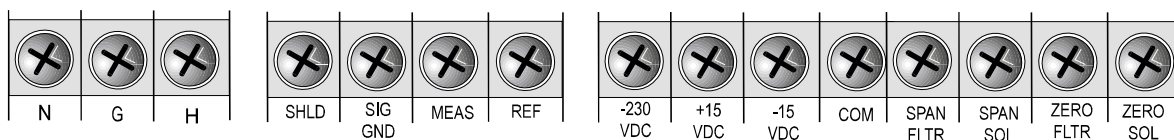

The first strip terminal has three contacts labeled N, G and H. The labels stand for Neutral, Ground, and Hot. This is the AC power strip terminal. It feeds AC power to other components of the Model 6000B System, such as the D2 lamp power supply, heater, and temperature controller PCB.

The second strip terminal has four contacts labeled SHLD, SIG, GND, MEAS and REF. This strip terminals are dedicated to the signals coming from the photodetector amplifier. The labels stand for:

**SHLD:** Shield. Shield form the preamplifier cable connects to this contact.

**SIG GND:** Signal Ground. Ground reference for both the measure and the reference signal.

**MEAS:** Measure Signal voltage.

**REF:** Reference Signal voltage.

The third terminal strip has eight contacts labeled -230 VDC, +15 VDC, -15 VDC, COM, SPAN FLTR, SPAN SOL, ZERO FLTR, ZERO SOL. This strip feeds the high voltage needed on the cathode of the photodetector, DC power for the photodetector preamplifier, and control signals for the solenoids and filters. The labels stand for:

**-230 VDC:** This is the negative high voltage fed to the photodetector cathode, about -230 VDC.

**+15 VDC:** Power Supply voltage fed to the photodetector preamplifier, +15 VDC.

**-15 VDC:** Power Supply voltage fed to the photodetector preamplifier, -15 VDC.

**COM:** Common reference to the +/- 15 VDC and the -230 VDC power supplies.

**SPAN FLTR:** Span filter signal, AC voltage.

**SPAN SOL:** Span solenoid signal, AC voltage.

**ZERO FLTR:** Zero filter signal, AC voltage.

**ZERO SOL:** Zero solenoid signal, AC voltage.



## **Appendix**

---

### **A-1 Specifications**

#### ***6000B Digital Control Module:***

**Ranges:** Four Programmable Ranges, field selectable within limits (application dependent) and Auto Ranging

**Display:** 2 line by 20 alphanumeric VFD accompanied by 5 digit LED display

**Signal Output:** Two 0-1V DC (concentration and range ID)  
Two 4-20mADC isolated (concentration and range ID)  
RS232

**Alarm:** Two fully programmable concentration alarm set points and corresponding Form C, 3 amp contacts. One system failure alarm contact to detect power, calibration, zero/span and sensor failure.

**Mounting:** Bulkhead Mount, NEMA-4 rated

**Operating Temperature:** 0-50°C

***Typical Analytical Performance Specifications:****(will vary per application)***Accuracy:**  $\pm 1\%$  of full scale possible**Noise:** Less than  $\pm 1\%$ **Drift:** Less than 1% per day (source/detector dependent)**Diurnal:** Less than 1% per 20°F (source/detector dependent)**Sample Cell:** Stainless steel with Quartz window standard. Other materials available.**Cell Length:** .01 to 40 inches**Flow Rate:** 50 to 1500 cc/min**Light Source:** Tungsten Lamp, Mercury, Deuterium Arc**Sensitivity:** .02 to 3 absorbance units.**Reproducibility:**  $\pm 2\%$  of scale or better**Filter Wavelength:** 210 to 1000 millimicrons, application dependent**Sample Pressure:** Quartz window: 30 psi



---

## A-2 Recommended 2-Year Spare Parts List

### QtyP/NDescription

	C-75825A	Motherboard, Control Unit
	C-67999	Amplifier, Control Unit
	D-67990	6000B Interface PCB
1	C-54799	D2 Power Supply
1	C-54802	Controller, D2 Power Supply
1	C-14449	Temperature Controller, Sample Cell
1	L-179	Source Lamp
5	F-57	Fuse, 5A Slo-Blo
5	F-14	Fuse, 10A Slo-Blo
1	P-43	Phototube
2	C87	Sample Cell Window (Quartz)
6	O81	Viton O-Ring
1	A-16776	Accessory Kit
2	F1268	Fuse, 6.3 A Fast-blo

---

**Note:** Orders for replacement parts should include the part number (if available) and the model and serial number of the instrument for which the parts are intended.

Orders should be sent to:

### **TELEDYNE Analytical Instruments**

16830 Chestnut Street  
City of Industry, CA 91749-1580

Phone (626) 934-1500, Fax (626) 961-2538  
TWX (910) 584-1887 TDYANYL COID

Web: [www.teledyne-ai.com](http://www.teledyne-ai.com)

or your local representative.

### A-3 Drawing List

A63532:	Piping Diagram
D-67989	Interface PCB Schematic
D-67998	Amplifier PCB Schematic
A-38750	Phototube Power Supply Schematic
B-36470	Detector Module-Phototube Schematic
C-73779	Photo Detector Amp PCBA Schematic
B-55819	D2 Power Supply Module Schematic
D-54797	D2 Power Supply PCB Schematic
B-15016	Temperature Controller PCB-Sample Cell Schematic
A-40510	Sample Cell Heater Schematic
D-54800	Controller PCB, D2 Lamp Schematic
C-36468	Detector Module-Phototube Schematic
C55106	D2 Source Power Supply Schematic
B-55110	Back Panel, D2 Power Supply Wiring Diagram
D-71637	Interconnection Wiring Diagram