

INSTRUCTION MANUAL

MODEL 6400E UV FLUORESCENCE SO₂ ANALYZER

© TELEDYNE ANALYTICAL INSTRUMENTS

16830 Chestnut Street

PO Box 1580

City of Industry, Ca. 91748

Phone: 626- 934-1500

Phone: 626-961-9221

Fax: 626-961-2538

DECLARATION OF CONFORMITY

APPLICATION OF COUNCIL DIRECTIVE : 89 / 336 EEC
73 / 23 / EEC

STANDARDS TO WHICH CONFORMITY IS DECLARED : EN61326 (1997 w/A1: 98) Class A
: EN 61010 - 1 : 2001 (2nd Edition)

MANUFACTURER'S NAME : TELEDYNE ANALYTICAL INSTRUMENTS

MANUFACTURER'S ADDRESS : 16830 Chestnut Street
City of Industry, CA 91748-1020
U.S.A.

TYPE OF EQUIPMENT : SO2 Analyzer

MODEL NUMBER : 6400E and 6400EH

I, THE UNDERSIGNED, HEREBY DECLARE THAT THE EQUIPMENT SPECIFIED ABOVE CONFORMS TO THE ABOVE STANDARD(S) PER 89/336/EEC AND 73/23/EEC.

SIGNATURE:  _____

FULL NAME: Stephen Broy

POSITION: Director of Engineering





DATE: 6-18-09

PLACE: City of Industry, California

SAFETY MESSAGES

Your safety and the safety of others is very important. We have provided many important safety messages in this manual. Please read these messages carefully.

A safety message alerts you to potential hazards that could hurt you or others. Each safety message is associated with a safety alert symbol. These symbols are found in the manual and inside the instrument. The definition of these symbols is described below:

	GENERAL SAFETY HAZARD: Refer to the instructions for details on the specific hazard.
	CAUTION: Hot Surface Warning
	CAUTION: Electrical Shock Hazard
	TECHNICIAN SYMBOL: All operations marked with this symbol are to be performed by qualified maintenance personnel only.

CAUTION

The analyzer should only be used for the purpose and in the manner described in this manual. If you use the analyzer in a manner other than that for which it was intended, unpredictable behavior could ensue with possible hazardous consequences.

NOTE

Technical Assistance regarding the use and maintenance of the Model 6400E UV Fluorescence SO₂ Analyzer or any other Teledyne Instruments product can be obtained by:

Contacting Teledyne Analytical Instruments' Customer Service Department at 626-934-1673

TABLE OF CONTENTS

1. 6400E DOCUMENTATION	1
1.1. Using This Manual	1
2. SPECIFICATIONS, APPROVALS AND WARRANTY	5
2.1. Specifications	5
2.2. EPA Equivalency Designation	6
2.3. CE Mark Compliance	7
2.4. Warranty	7
3. GETTING STARTED	9
3.1. Unpacking and Initial Setup	9
3.1.1. Electrical Connections:	10
3.1.1.1. Connecting the Analog Outputs	11
3.1.1.2. Connecting the Status Outputs	12
3.1.1.3. Connecting the Control Inputs	13
3.1.1.4. Connecting the Serial Ports	14
3.1.1.5. Connecting to a LAN or the Internet	14
3.1.1.6. Connecting to a Multidrop Network	14
3.1.2. Pneumatic Connections:	15
3.1.2.1. Calibration Gases	16
3.1.2.2. Pneumatic Connections to 6400E Basic Configuration:	17
3.1.2.3. Connections with Internal Valve Options Installed	19
3.2. Initial Operation	21
3.2.1. Startup	21
3.2.2. Warm-Up	22
3.2.3. Warning Messages	22
3.2.4. Functional Check	24
3.3. Initial Calibration	26
3.3.1. Basic Calibration Procedure	26
3.3.2. Interferences for SO ₂ Measurements	28
4. FREQUENTLY ASKED QUESTIONS & GLOSSARY	29
4.1. FAQ's	29
4.2. Glossary	30
5. OPTIONAL HARDWARE AND SOFTWARE	33
5.1. Rack Mount Kits (Options 20a, 20b & 21)	33
5.2. Current Loop Analog Outputs (Option 41)	33
5.2.1. Converting Current Loop Analog Outputs to Standard Voltage Outputs.	34
5.3. Particulate Filter Kit (Option 42A)	34
5.4. Calibration Valves Options	35
5.4.1. Zero/Span Valves (Option 50)	35
5.4.2. Internal Zero/Span Gas Generator (Option 51)	36
5.4.3. IZS Permeation Tubes (Options 53, 55 & 57)	38
5.4.4. Zero Air Scrubber Maintenance Kit (Option 43)	38
5.5. Communication Options	39
5.5.1. RS232 Modem Cable (Option 60)	39
5.5.2. RS-232 Multidrop (Option 62)	39
5.5.3. Ethernet (Option 63)	39
5.6. Additional Manuals	41
5.6.1. Printed Manuals (Option 70)	41
5.6.2. Manual on CD (Part number 045150200)	Error! Bookmark not defined.
5.7. Extended Warranty (Options 92 & 93)	41
5.8. Special Software Features	41
5.8.1. Maintenance Mode Switch	41
5.8.2. Second Language Switch	41
5.8.3. Dilution Ratio Option	42
6. OPERATING INSTRUCTIONS	43
6.1. Overview of Operating modes	43
6.2. Sample Mode	44

6.2.1. Test Functions.....	44
6.2.2. Warning Messages.....	47
6.3. Calibration Mode.....	48
6.3.1. Calibration Functions.....	48
6.3.2. SETUP – PASS: Calibration Password Security.....	49
6.4. Setup Mode.....	50
6.4.1. Setup Mode Password Security.....	51
6.5. SETUP – CFG: Viewing the Analyzer’s Configuration Information.....	51
6.6. SETUP – CLK: Setting the Internal Time-of-Day Clock.....	52
6.7. SETUP – RNGE: Analog Output Reporting Range Configuration.....	54
6.7.1. Available Analog Output Signals.....	54
6.7.2. Physical Range versus Analog Output Reporting Ranges.....	55
6.7.3. Reporting Range Modes.....	56
6.7.4. Single Range mode (SNGL).....	57
6.7.5. Dual Range Mode (DUAL).....	58
6.7.6. Auto Range Mode (AUTO).....	59
6.7.7. Range Units.....	60
6.7.8. Dilution Ratio.....	61
6.8. SETUP – VARS: Using the Internal Variables.....	62
6.9. SETUP – DIAG: Using the Diagnostics Functions.....	64
6.9.1. Accessing the Diagnostic Features.....	65
6.9.2. Signal I/O.....	66
6.9.3. Analog Output Step Test.....	67
6.9.4. Analog I/O Configuration.....	68
6.9.4.1. Analog Output Signal Type and Range Span Selection.....	70
6.9.4.2. Analog Output Calibration Mode.....	71
6.9.4.3. Manual Analog Output Calibration and Voltage Adjustment.....	73
6.9.4.4. Analog Output Offset Adjustment.....	75
6.9.4.5. Current Loop Output Adjustment.....	76
6.9.4.6. AIN Calibration.....	78
6.9.5. Optic Test.....	79
6.9.6. Electrical Test.....	80
6.9.7. Lamp Calibration.....	81
6.9.8. Pressure Calibration.....	82
6.9.9. Flow Calibration.....	83
6.9.10. Test Channel Output.....	84
6.10. SETUP – COMM: Setting Up the Analyser’s Communication Ports.....	85
6.10.1. Analyzer ID.....	85
6.10.2. COM Port Default Settings.....	86
6.10.3. RS-232 COM Port Cable Connections.....	86
6.10.4. RS-485 Configuration of COM2.....	87
6.10.5. DTE and DCE Communication.....	89
6.10.6. Ethernet Card Configuration.....	90
6.10.6.1. Ethernet Card COM2 Communication Modes and Baud Rate.....	90
6.10.6.2. Configuring the Ethernet Interface Option using DHCP.....	90
6.10.6.3. Manually Configuring the Network IP Addresses.....	93
6.10.6.4. Changing the Analyzer’s HOSTNAME.....	95
6.10.7. Multidrop RS-232 Set Up.....	96
6.10.8. COM Port Communication Modes.....	98
6.10.9. COM Port Baud Rate.....	100
6.10.10. COM Port Testing.....	101
6.11. Using the Data Acquisition System (iDAS).....	102
6.11.1. iDAS Structure.....	103
6.11.1.1. iDAS Channels.....	103
6.11.1.2. iDAS Parameters.....	104
6.11.1.3. iDAS Triggering Events.....	104
6.11.2. Default iDAS Channels.....	105
6.11.2.1. Viewing iDAS Data and Settings.....	107
6.11.2.2. Editing iDAS Data Channels.....	108
6.11.2.3. Trigger Events.....	109
6.11.2.4. Editing iDAS Parameters.....	110
6.11.2.5. Sample Period and Report Period.....	111

6.11.2.6. Number of Records	114
6.11.2.7. RS-232 Report Function	115
6.11.2.8. Compact Report	115
6.11.2.9. Starting Date	115
6.11.2.10. Disabling/Enabling Data Channels.....	116
6.11.2.11. HOLDOFF Feature.....	117
6.11.3. Remote iDAS Configuration	118
6.12. Remote Operation of the Analyzer	120
6.12.1. Remote Operation Using the External Digital I/O	120
6.12.1.1. Status Outputs.....	120
6.12.1.2. Control Inputs.....	121
6.12.2. Remote Operation Using the External Serial I/O	123
6.12.2.1. Terminal Operating Modes.....	123
6.12.2.2. Help Commands in Terminal Mode.....	123
6.12.2.3. Command Syntax.....	124
6.12.2.4. Data Types.....	124
6.12.2.5. Status Reporting	125
6.12.2.6. Remote Access by Modem	126
6.12.2.7. COM Port Password Security	127
6.12.2.8. APICOM Remote Control Program.....	128
6.12.3. Additional Communications Documentation	129
6.12.4. Using the 6400E with a Hessen Protocol Network.....	130
6.12.4.1. General Overview of Hessen Protocol	130
6.12.4.2. Hessen COMM Port Configuration	130
6.12.4.3. Activating Hessen Protocol.....	131
6.12.4.4. Selecting a Hessen Protocol Type	131
6.12.4.5. Setting The Hessen Protocol Response Mode.....	132
6.12.4.6. Hessen Protocol Gas ID.....	132
6.12.4.7. Setting Hessen Protocol Status Flags	133
6.12.4.8. Instrument ID Code.....	135
7. CALIBRATION PROCEDURES	137
7.1. Calibration Preparations.....	137
7.1.1. Required Equipment, Supplies, and Expendables	137
7.1.2. Zero Air.....	137
7.1.3. Calibration Gas Standards & Traceability	138
7.1.4. Permeation Tubes.....	138
7.1.5. Calibration Gas.....	138
7.1.6. Data Recording Devices.....	138
7.2. Manual Calibration	139
7.3. Manual Calibration Checks.....	141
7.4. Manual Calibration with Zero/Span Valves.....	142
7.5. Manual Calibration with IZS Option	144
7.6. Manual Calibration Checks with Izs or Zero/Span Valves	145
7.7. Manual Calibration in DUAL or AUTO Reporting Range Modes.....	147
7.7.1. Calibration With Remote Contact Closures	147
7.8. Automatic Calibration (AutoCal)	148
7.9. Calibration Quality	151
8. EPA PROTOCOL CALIBRATION	153
8.1. Calibration Requirements	153
8.1.1. Calibration of Equipment	153
8.1.2. Data Recording Device	155
8.1.3. Recommended Standards for Establishing Traceability.....	155
8.1.4. EPA Calibration Using Permeation Tubes.....	155
8.1.5. Calibration Frequency	155
8.1.6. Record Keeping	156
8.1.7. Summary of Quality Assurance Checks.....	156
8.2. Level 1 Calibrations versus Level 2 Checks	157
8.3. ZERO and SPAN Checks	158
8.3.1. Zero/Span Check Procedures	158
8.4. Precisions Calibration Procedures and Checks	159
8.4.1. Precision Calibration.....	159

8.4.2. Precision Check	159
8.5. Dynamic Multipoint Span Calibration	160
8.6. Special Calibration Requirements for Dual Range or Auto Range	161
8.7. References	161
9. INSTRUMENT MAINTENANCE.....	163
9.1. Maintenance Schedule	164
9.2. Predictive Diagnostics.....	165
9.3. Maintenance Procedures	166
9.3.1. Changing the Sample Particulate Filter	166
9.3.2. Changing the IZS Permeation Tube.....	167
9.3.3. Changing the External Zero Air Scrubber	167
9.3.4. Changing Critical Flow Orifices	168
9.3.5. Checking for Light Leaks.....	169
10. THEORY OF OPERATION.....	171
10.1. Measurement Principle	171
10.1.1. SO ₂ Ultraviolet Fluorescence.....	171
10.2. The UV Light Path.....	174
10.2.1. UV Source Lamp	174
10.2.2. The Reference Detector	175
10.2.3. The PMT	175
10.2.4. UV Lamp Shutter & PMT Offset	175
10.2.5. Optical Filters	176
10.2.6. Optical Lenses	177
10.2.7. Measurement Interferences.....	178
10.2.7.1. Direct Interference	178
10.2.7.2. UV Absorption by Ozone.....	178
10.2.7.3. Dilution	179
10.2.7.4. Third Body Quenching.....	179
10.2.7.5. Light Pollution	179
10.3. Pneumatic Operation	180
10.3.1. Sample Gas Flow	180
10.3.2. Flow Rate Control	181
10.3.2.1. Critical Flow Orifice.....	181
10.3.3. Sample Particulate Filter	182
10.3.4. Hydrocarbon Scrubber (<i>Kicker</i>).....	182
10.3.5. Pneumatic Sensors.....	183
10.3.5.1. Sample Pressure Sensor.....	183
10.3.5.2. Sample Flow Sensor	183
10.4. Electronic Operation	184
10.4.1. CPU	186
10.4.1.1. Disk On Chip.....	186
10.4.1.2. Flash Chip	187
10.4.2. Sensor Module.....	187
10.4.2.1. Sample Chamber.....	188
10.4.2.2. Sample Chamber Heating Circuit.....	188
10.4.3. Photo Multiplier Tube (PMT)	189
10.4.4. PMT Cooling System.....	191
10.4.4.1. Thermoelectric Cooler (TEC)	191
10.4.4.2. TEC Control Board	191
10.4.5. PMT Preamplifier.....	192
10.4.6. Pneumatic Sensor Board	193
10.4.7. Relay Board	193
10.4.7.1. Heater Control	193
10.4.7.2. Valve Control.....	193
10.4.8. Status LEDs & Watch Dog Circuitry	194
10.4.9. Motherboard	195
10.4.9.1. A to D Conversion	195
10.4.9.2. Sensor Inputs	195
10.4.9.3. Thermistor Interface.....	196
10.4.10. Analog Outputs.....	196
10.4.11. External Digital I/O	197

10.4.12. I ² C Data Bus	197
10.4.13. Power up Circuit	197
10.5. Power Supply/ Circuit Breaker.....	198
10.6. Communications Interface.....	199
10.6.1. Front Panel Interface.....	200
10.6.1.1. Analyzer Status LED's	200
10.6.1.2. Keyboard	200
10.6.1.3. Display	201
10.6.1.4. Keyboard/Display Interface Electronics	201
10.7. Software Operation	204
10.7.1. Adaptive Filter.....	204
10.7.2. Calibration - Slope and Offset.....	205
10.7.3. Temperature and Pressure Compensation (TPC) Feature.....	205
10.7.4. Internal Data Acquisition System (iDAS).....	206
11. TROUBLESHOOTING & REPAIR	207
11.1. General Troubleshooting	207
11.1.1. Warning Messages	208
11.1.2. Fault Diagnosis with Test Functions.....	210
11.1.3. Using the Diagnostic Signal I/O Functions	212
11.1.4. Status LEDs	213
11.1.4.1. Motherboard Status Indicator (Watchdog).....	213
11.1.4.2. CPU Status Indicator.....	213
11.1.4.3. Relay Board Status LEDs.....	214
11.2. Gas Flow Problems	215
11.2.1. Zero or Low Sample Flow.....	215
11.2.2. High Flow	215
11.3. Calibration Problems.....	216
11.3.1. Negative Concentrations.....	216
11.3.2. No Response	216
11.3.3. Unstable Zero and Span	217
11.3.4. Inability to Span - No SPAN Key	217
11.3.5. Inability to Zero - No ZERO Key.....	217
11.3.6. Non-Linear Response	218
11.3.7. Discrepancy Between Analog Output and Display	218
11.4. Other Performance Problems	219
11.4.1. Excessive noise	219
11.4.2. Slow Response	219
11.4.3. The Analyzer Doesn't Appear on the LAN or Internet.....	219
11.5. Subsystem Checkout	221
11.5.1. Detailed Pressure Leak Check.....	221
11.5.2. Performing a Sample Flow Check	222
11.5.3. Hydrocarbon Scrubber (<i>Kicker</i>).....	222
11.5.3.1. Checking the Scrubber for Leaks	222
11.5.3.2. Checking the Scrubber's Efficiency.....	223
11.5.4. AC Power Configuration	224
11.5.5. DC Power Supply	225
11.5.6. I ¹ C Bus.....	226
11.5.7. Keyboard / Display Interface	226
11.5.8. Relay Board	227
11.5.9. Motherboard	227
11.5.9.1. A/D functions.....	227
11.5.9.2. Analog Output Voltages.....	228
11.5.9.3. Status Outputs.....	228
11.5.9.4. Control Inputs.....	229
11.5.10. CPU.....	229
11.5.11. RS-232 Communication	230
11.5.11.1. General RS-232 Troubleshooting	230
11.5.11.2. Modem or Terminal Operation	230
11.5.12. Shutter System	231
11.5.13. PMT Sensor	231
11.5.14. PMT Preamplifier Board.....	231

11.5.15. PMT Temperature Control PCA	232
11.5.15.1. TEC Control Test Points	232
11.5.16. High Voltage Power Supply.....	232
11.5.17. Pneumatic Sensor Assembly	233
11.5.17.1. Sample Pressure	233
11.5.18. IZS Option	234
11.5.19. Box Temperature	234
11.5.20. PMT Temperature.....	234
11.6. Repair Procedures	235
11.6.1. Disk-on-Chip Replacement.....	235
11.6.2. Flash Chip Replacement or Upgrade	236
11.6.3. Sensor Module Repair & Cleaning.....	236
11.6.3.1. Removing and Reinstalling the Sensor Module:	237
11.6.3.2. Cleaning the Sample chamber.....	238
11.6.3.3. Cleaning the PMT Lens & PMT filter	240
11.6.3.4. Replacing the UV filter/lens	242
11.6.3.5. Adjusting the UV Lamp (<i>Peaking the Lamp</i>)	243
11.6.3.6. Replacing the UV Lamp	245
11.6.3.7. Replacing the PMT, HVPS or TEC	246
11.6.3.8. PMT Hardware Calibration (<i>FACTORY CAL</i>).....	248
11.7. Technical Assistance	250
12. A PRIMER ON ELECTRO-STATIC DISCHARGE	251
12.1. How Static Charges are Created.....	251
12.2. How Electro-Static Charges Cause Damage	252
12.3. Common Myths About ESD Damage	253
12.4. Basic Principles of Static Control.....	254
12.4.1. General Rules.....	254
12.4.2. Basic anti-ESD Procedures for Analyzer Repair and Maintenance.....	256
12.4.2.1. Working at the Instrument Rack.....	256
12.4.2.2. Working at a Anti-ESD Work Bench.	256
12.4.2.3. Transferring Components from Rack To Bench and Back	257
12.4.2.4. Opening Shipments from and Packing Components for Return to Teledyne Instruments	
Customer Service.....	258

LIST OF APPENDICES

APPENDIX A - VERSION SPECIFIC SOFTWARE DOCUMENTATION
APPENDIX A-1: 6400E Software Menu Trees, Revision C.3
APPENDIX A-2: Setup Variables For Serial I/O, Revision C.3
APPENDIX A-3: Warnings and Test Functions, Revision C.3
APPENDIX A-4: 6400E Signal I/O Definitions, Revision C.3
APPENDIX A-5: 6400E iDAS Functions, Revision C.3
APPENDIX A-6: Terminal Command Designators, Revision C.3
APPENDIX B - 6400E SPARE PARTS LIST
APPENDIX C - REPAIR QUESTIONNAIRE - 6400E
APPENDIX D - ELECTRONIC SCHEMATICS

LIST OF FIGURES

Figure 3-1: Rear Panel Layout.....	10
Figure 3-2: Analog Output Connector	11
Figure 3-3: Status Output Connector	12
Figure 3-4: Control Input Connector	13
Figure 3-5: Internal Pneumatic Diagram of the 6400E Standard Configuration.	16

Figure 3-6:	Pneumatic Connections–Basic Configuration–Using Gas Dilution Calibrator.....	17
Figure 3-7:	Pneumatic Connections–Basic Configuration–Using Bottled Span Gas	17
Figure 3-8:	Basic Pneumatic Connections for Units with Valve Options	19
Figure 3-9:	6400E Layout (Basic Unit – No Valve Options)	20
Figure 3-10:	Front Panel Layout	22
Figure 5-1:	Current Loop Option Installed on the Motherboard	33
Figure 5-2:	Pneumatic Diagram of the 6400E With Z/S Option Installed.	35
Figure 5-3:	Pneumatic Diagram of the 6400E with IZS Options Installed.	36
Figure 5-4:	6400E Multidrop Card.....	39
Figure 5-5:	6400E Ethernet Card	40
Figure 5-6:	6400E Rear Panel with Ethernet Installed.....	40
Figure 6-1:	Front Panel Display	43
Figure 6-2:	Viewing 6400E TEST Functions	46
Figure 6-3:	Viewing and Clearing 6400E WARNING Messages.....	47
Figure 6-4:	Analog Output Connector Key.....	54
Figure 6-5:	Setup for Calibrating Analog Outputs.....	73
Figure 6-6:	Setup for Calibrating Current Outputs.....	76
Figure 6-7:	Back Panel connector Pin-Outs for COM1 & COM2 in RS-232 mode.....	86
Figure 6-8:	CPU connector Pin-Outs for COM1 & COM2 in RS-232 mode.	87
Figure 6-9:	CPU card Locations of RS-232/486 Switches, Connectors and Jumpers	88
Figure 6-10:	Back Panel connector Pin-Outs for COM2 in RS-485 mode.	89
Figure 6-11:	CPU connector Pin-Outs for COM2 in RS-485 mode.	89
Figure 6-12:	Location of JP2 on RS232-Multidrop PCA (option 62)	96
Figure 6-13:	RS232-Multidrop PCA Host/Analyzer Interconnect Diagram	97
Figure 6-14:	Default iDAS Channels Setup.....	106
Figure 6-15:	Sample APICOM user interface for configuring the iDAS.	118
Figure 6-16:	iDAS Configuration Through a Terminal Emulation Program.....	119
Figure 6-17:	Status Output Connector.....	120
Figure 6-18:	Control Inputs with local 5 V power supply	122
Figure 6-19:	Control Inputs with external 5 V power supply	122
Figure 6-20:	APICOM Remote Control Program Interface	129
Figure 7-1:	Setup for Manual Calibration without Z/S valve or IZS Option	139
Figure 7-2:	Setup for Manual Calibration with Z/S Valve Option Installed.....	142
Figure 7-3:	Setup for Manual Calibration Check with Z/S Valve or IZS Option	145
Figure 9-1:	Sample Particulate Filter Assembly.....	166
Figure 9-2:	Critical Flow Orifice Assembly	168
Figure 10-1:	UV Absorption	172
Figure 10-2:	UV Light Path	174
Figure 10-3:	Source UV Lamp Construction.....	175
Figure 10-4:	Excitation Lamp UV Spectrum Before/After Filtration	176
Figure 10-5:	PMT Optical Filter Bandwidth	177
Figure 10-6:	Effects of Focusing Source UV in Sample Chamber	177
Figure 10-7:	6400E Gas Flow and Location of Critical Flow Orifice.....	180
Figure 10-8:	Flow Control Assembly & Critical Flow Orifice	181
Figure 10-9:	6400E Hydrocarbon Scrubber (Kicker)	182
Figure 10-10:	6400E Electronic Block Diagram	184
Figure 10-11:	6400E CPU Board	186
Figure 10-12:	6400E Sensor Module	187
Figure 10-13:	6400E Sample Chamber.....	188
Figure 10-14:	PMT Housing Assembly	189
Figure 10-15:	Basic PMT Design	190
Figure 10-16:	PMT Cooling System	191
Figure 10-17:	PMT Preamp Block Diagram	192
Figure 10-18:	Relay Board Status LED Locations	194
Figure 10-19:	Power Distribution Block Diagram.....	198

Figure 10-20: Interface Block Diagram.....	199
Figure 10-21: 6400E Front Panel Layout.....	200
Figure 10-22: Keyboard and Display Interface Block Diagram	201
Figure 10-23: Basic Software Operation	204
Figure 11-1: Viewing and Clearing warning messages	208
Figure 11-2: Example of Signal I/O Function	212
Figure 11-3: CPU Status Indicator	213
Figure 11-4: Simple Leak Check Fixture	222
Figure 11-5: Hydrocarbon Scrubber Leach check Set Up.....	223
Figure 11-6: Location of Relay Board Power Configuration Jumper.....	225
Figure 11-7: Sensor Module Wiring and Pneumatic Fittings.....	236
Figure 11-8: Sensor Module Mounting Screws	238
Figure 11-9: Sample Chamber Mounting Bracket.....	239
Figure 11-10: Hex Screw Between Lens Housing and Sample chamber.....	240
Figure 11-11: UV Lens Housing / Filter Housing.....	240
Figure 11-12: PMT UV Filter Housing Disassembled.....	241
Figure 11-13: Disassembling the Shutter Assembly	242
Figure 11-14: Shutter Assembly - Exploded View	243
Figure 11-15: Location of UV Reference Detector Potentiometer	244
Figure 11-16: PMT Assembly - Exploded View	246
Figure 11-17: Pre-Amplifier Board Layout.....	248
Figure 12-1: Triboelectric Charging.....	251
Figure 12-2: Basic anti-ESD Work Station.....	254
Figure A-1: Basic Sample Display Menu.....	260
Figure A-2: Sample Display Menu - Units with Z/S Valve or IZS Option installed.....	261
Figure A-3: Primary Setup Menu (Except iDAS)	262
Figure A-4: Primary Setup Menu (iDAS)	263
Figure A-5: Secondary Setup Menu (COMM & VARS).....	264
Figure A-6: Secondary Setup Menu (COMM Menu with Ethernet Card).....	265
Figure A-7: Secondary Setup Menu - HESSEN Submenu	266
Figure A-8: Secondary Setup Menu (DIAG).....	267

LIST OF TABLES

Table 2-1: Model 6400E Basic Unit Specifications	5
Table 3-1: Analog output Pin Outs.....	11
Table 3-2: Status Output Signals.....	12
Table 3-3: Control Input Signals.....	13
Table 3-4: Inlet / Outlet Connector Nomenclature.....	15
Table 3-5: NIST-SRM's Available for Traceability of SO ₂ Calibration Gases	16
Table 3-6: Front Panel Display During System Warm-Up	22
Table 3-7: Possible Warning Messages at Start-Up.....	23
Table 5-1: Zero/Span Valve Operating States	35
Table 5-2: IZS Valve Operating States	37
Table 6-1: Analyzer Operating modes	44
Table 6-2: Test Functions Defined.....	45
Table 6-3: List of Warning Messages	47
Table 6-4: Primary Setup Mode Features and Functions.....	50
Table 6-5: Secondary Setup Mode Features and Functions.....	50
Table 6-6: Variable Names (VARS) Revision C.3	62
Table 6-7: 6400E Diagnostic (DIAG) Functions.....	64
Table 6-8: DIAG - Analog I/O Functions	68
Table 6-9: Analog Output Voltage Ranges.....	68
Table 6-10: Analog Output Current Loop Range.....	69

Table 6-11:	Analog Output Pin Assignments.....	69
Table 6-12:	Voltage Tolerances for Analog Output Calibration	73
Table 6-13:	Current Loop Output Calibration with Resistor.....	77
Table 6-14:	Test Parameters Available for Analog Output A4.....	84
Table 6-15:	Ethernet Status Indicators.....	90
Table 6-16:	LAN/Internet Configuration Properties.....	91
Table 6-17:	Internet Configuration Keypad Functions.....	95
Table 6-18:	COMM Port Communication modes	98
Table 6-19:	Front Panel LED Status Indicators for iDAS.....	102
Table 6-20:	iDAS Data Channel Properties	103
Table 6-21:	iDAS Data Parameter Functions.....	104
Table 6-22:	Status Output Pin Assignments	121
Table 6-23:	Control Input Pin Assignments	121
Table 6-24:	Terminal Mode Software Commands.....	123
Table 6-25:	Command Types	124
Table 6-26:	Serial Interface Documents	129
Table 6-27:	RS-232 Communication Parameters for Hessen Protocol	130
Table 6-28:	6400E Hessen Protocol Response Modes	132
Table 6-29:	Default Hessen Status Bit Assignments	133
Table 7-1:	NIST-SRM's Available for Traceability of SO ₂ Calibration Gases.....	138
Table 7-2:	AutoCal Modes.....	148
Table 7-3:	AutoCal Attribute Setup Parameters	148
Table 7-4:	Example Auto-Cal Sequence.....	149
Table 7-5:	Calibration Data Quality Evaluation	151
Table 8-1:	Activity Matrix for Calibration Equipment & Supplies.....	154
Table 8-2:	Activity Matrix for Calibration Procedure.....	154
Table 8-3:	Activity Matrix for Quality Assurance Checks.....	156
Table 8-4:	Definition of Level 1 and Level 2 Zero and Span Checks	157
Table 9-1:	6400E Preventive Maintenance Schedule.....	164
Table 9-2:	Predictive Uses for Test Functions	165
Table 10-1:	Relay Board Status LED's	194
Table 10-2:	Front Panel Status LED's	200
Table 11-1:	Warning Messages - Indicated Failures.....	209
Table 11-2:	Test Functions - Possible Causes for Out-Of-Range Values.....	211
Table 11-3:	Relay Board Status LEDs.....	214
Table 11-4:	DC Power Test Point and Wiring Color Code	225
Table 11-5:	DC Power Supply Acceptable Levels.....	225
Table 11-6:	Relay Board Control Devices.....	227
Table 11-7:	Analog Output Test Function - Nominal Values.....	228
Table 11-8:	Status Outputs Check Pin Out.....	228
Table 11-9:	Example of HVPS Power Supply Outputs	233
Table 11-10:	Example of HVPS Power Supply Outputs.....	244
Table 12-1:	Static Generation Voltages for Typical Activities	252
Table 12-2:	Sensitivity of Electronic Devices to Damage by ESD.....	252
Table A-1:	6400E Setup Variables, Revision C.3	268
Table A-2:	6400E Warning Messages, Revision C.3	274
Table A-3:	6400E Test Functions, Revision C.3	275
Table A-4:	6400E Signal I/O Definitions, Revision C.3	276
Table A-5:	6400E DAS Trigger Events, Revision C.3.....	280
Table A-6:	6400E iDAS Functions, Revision C.3	281
Table A-7:	Terminal Command Designators, Revision C.3	282
Table B-1:	6400E Spare Parts List	285
Table D-1:	List of Included Electronic Schematics	289

1. 6400E DOCUMENTATION

Thank you for purchasing the Model 6400E UV Fluorescence SO₂ Analyzer!

The documentation for this instrument is available in several different formats:

- Printed format, part number 045150100

Additional documentation for the Model 6400E UV Fluorescence SO₂ Analyzer is available from Teledyne Instruments' website at <http://www.teledyne-api.com/manuals/>

- APICOM software manual, part number 03945
- Multi-drop manual, part number 01842
- DAS Manual, part number 02837.

1.1. USING THIS MANUAL

This manual has the following data structures:

1.0 Table of Contents:

Outlines the contents of the manual in the order the information is presented. This is a good overview of the topics covered in the manual. There is also a list of tables, a list of figures and a list of appendices. In the electronic version of the manual, clicking on any of these table entries automatically views that section.

2.0 Specifications and Warranty

This section contains a list of the analyzer's performance specifications, a description of the conditions and configuration under which EPA equivalency was approved and TAI's warranty statement.

3.0 Getting Started:

A concise set of instructions for setting up, installing and running your analyzer for the first time.

4.0 FAQ:

Answers to the most frequently asked questions about operating the analyzer.

5.0 Optional Hardware & Software

A description of optional equipment to add functionality to your analyzer.

6.0 Operation Instructions

This section includes step by step instructions for operating the analyzer and using its various features and functions.

7.0 Calibration Procedures

General information and step by step instructions for calibrating your analyzer.

8.0 EPA Protocol Calibration

Specific information regarding calibration requirements for analyzers used in EPA-regulated monitoring applications.

9.0 Instrument Maintenance

Description of certain preventative maintenance procedures that should be regularly performed on you instrument to keep it in good operating condition. This section also includes information on using the iDAS to record diagnostic functions useful in predicting possible component failures before they happen.

10.0 Theory of Operation

An in-depth look at the various principals by which your analyzer operates as well as a description of how the various electronic, mechanical and pneumatic components of the instrument work and interact with each other. A close reading of this section is invaluable for understanding the instrument's operation.

11.0 Troubleshooting Section:

This section includes pointers and instructions for diagnosing problems with the instrument, such as excessive noise or drift, as well as instructions on performing repairs of the instrument's major subsystems.

11.0 Electro-static Discharge Primer

This section describes how static electricity occurs; why it is a significant concern and; how to avoid it and avoid allowing ESD to affect the reliable and accurate operation of your analyzer.

Appendices:

For easier access and better updating, some information has been separated out of the manual and placed in a series of appendices at the end of this manual. These include: software menu trees, warning messages, definitions of iDAS & serial I/O variables, spare parts list, repair questionnaire, interconnect listing and drawings, and electronic schematics.

NOTE

Throughout this manual, words printed in capital, bold letters, such as **SETUP** or **ENTR** represent messages as they appear on the analyzer's front panel display.

NOTE

The flowcharts in this manual contain typical representations of the analyzer's display during the various operations being described. These representations are not intended to be exact and may differ slightly from the actual display of your instrument.

User Notes:

2. SPECIFICATIONS, APPROVALS AND WARRANTY

2.1. SPECIFICATIONS

Table 2-1: Model 6400E Basic Unit Specifications

Min/Max Range (Physical Analog Output)	In 1ppb increments from 50ppb to 20 000ppb, dual ranges or auto ranging
Measurement Units	ppb, ppm, µg/m ³ , mg/m ³ (user selectable)
Zero Noise ¹	0.2 ppb RMS
Span Noise ¹	0.2 ppb RMS
Lower Detectable Limit ²	0.4 ppb RMS
Zero Drift (24 hours)	<0.5 ppb
Zero Drift (7 days)	1 ppb
Span Drift (7 Days)	<0.5% FS
Linearity	1% of full scale
Precision	0.5% of reading ¹
Temperature Coefficient	< 0.1% per °C
Voltage Coefficient	< 0.05% per V
Lag Time ¹	20 sec
Rise/Fall Time ¹	95% in <100 sec
Sample Flow Rate	650cc/min. ±10%
Temperature Range	5-40°C
Humidity Range	0 - 95% RH, non-condensing
Dimensions H x W x D	7" x 17" x 23.5" (178 mm x 432 mm x 597 mm)
Weight, Analyzer (Basic Configuration)	45 lbs (20.5 kg) w/internal pump
AC Power Rating	100 V, 50/60 Hz (3.25A); 115 V, 60 Hz (3.0 A); 220 - 240 V, 50/60 Hz (2.5 A)
Environmental	Installation category (over-voltage category) II; Pollution degree 2
Analog Outputs	Three (3) Outputs
Analog Output Ranges	100 mV, 1 V, 5 V, 10 V, 2-20 or 4-20 mA isolated current loop. All Ranges with 5% Under/Over Range
Analog Output Resolution	1 part in 4096 of selected full-scale voltage
Status Outputs	8 Status outputs from opto-isolators
Control Inputs	6 Control Inputs, 3 defined, 3 spare
Serial I/O	One (1) RS-232; One (1) RS-485 (2 connectors in parallel) Baud Rate : 300 - 115200; Optional Ethernet Interface
Certifications	EN61326 (1997 w/A1: 98) Class A, FCC Part 15 Subpart B Section 15.107 Class A, ICES-003 Class A (ANSI C63.4 1992) & AS/NZS 3548 (w/A1 & A2; 97) Class A. IEC 61010-1:90 + A1:92 + A2:95,
1 As defined by the USEPA.	
2 Defined as twice the zero noise level by the USEPA.	

2.2. EPA EQUIVALENCY DESIGNATION

The Model 6400E Analyzer is designated as Reference Method Number EQSA-0495-100 as per 40 CFR Part 53 when operated under the following conditions:

- Range: Any range from 50 parts per billion (ppb) to 10 parts per million (ppm).
- Ambient temperature range of 5 °C to 40 °C.
- Line voltage range of 105-125 VAC or 220-240 VAC, at 50 or 60 Hz.
- Sample filter: Equipped with PTFE filter element in the internal filter assembly.
- Sample flow of 650 +/- 65 cc/min.
- Vacuum pump (internal) capable of 14"Hg Absolute pressure @ 1 slpm or better.
- Software settings:

Dynamic span	OFF
Dynamic zero	OFF
Dilution factor	OFF
AutoCal	ON or OFF
Dual range	ON or OFF
Auto-range	ON or OFF
Temp/Pressure compensation	ON

Under the designation, the analyzer may be operated with or without the following optional equipment:

- Rack mount with chassis slides.
- Rack mount without slides, ears only.
- Zero/span valve options.
- Internal zero/span (IZS) option with either:
 1. SO₂ permeation tube - 0.4ppm at 0.7 liter per minute; certified/uncertified.
 2. SO₂ permeation tube - 0.8 ppm at 0.7 liter per minute; certified/uncertified. Under the designation, the IZS option cannot be used as the source of calibration.
- 4-20mA isolated analog outputs.
- Status outputs.
- Control inputs.
- RS-232 output.
- Ethernet output.
- Zero air scrubber.
- 4-20mA, isolated output.

2.3. CE MARK COMPLIANCE

Emissions Compliance

The Teledyne Analytical Instruments UV Fluorescence SO₂ Analyzer 6400E was tested and found to be fully compliant with:

EN61326 (1997 w/A1: 98) Class A, FCC Part 15 Subpart B Section 15.107 Class A, ICES-003 Class A (ANSI C63.4 1992) & AS/NZS 3548 (w/A1 & A2; 97) Class A.

Tested on 21 February 2003 - 08 March 2003 at CKC Laboratories, Inc., Report Number CE03-021A.

Safety Compliance

The Teledyne Analytical Instruments UV Fluorescence SO₂ Analyzer 6400E was tested and found to be fully compliant with:

IEC 61010-1:90 + A1:92 + A2:95,

Issued by CKC Laboratories on 4 April 2003, Report Number WO-80146.

2.4. WARRANTY

Warranty Policy

Prior to shipment, Teledyne Analytical Instruments equipment is thoroughly inspected and tested. Should equipment failure occur, Teledyne Analytical Instruments assures its customers that prompt service and support will be available.

Coverage

After the warranty period and throughout the equipment lifetime, Teledyne Analytical Instruments stands ready to provide on-site or in-plant service at reasonable rates similar to those of other manufacturers in the industry. All maintenance and the first level of field troubleshooting is to be performed by the customer.

Non-TELEDYNE ANALYTICAL INSTRUMENTS Manufactured Equipment

Equipment provided but not manufactured by Teledyne Analytical Instruments is warranted and will be repaired to the extent and according to the current terms and conditions of the respective equipment manufacturers warranty.

General

Teledyne Analytical Instruments warrants each product manufactured by Teledyne Analytical Instruments to be free from defects in material and workmanship under normal use and service for a period of one year from the date of delivery. All replacement parts and repairs are warranted for 90 days after the purchase.

If a product fails to conform to its specifications within the warranty period, Teledyne Analytical Instruments shall correct such defect by, in Teledyne analytical Instruments discretion, repairing or replacing such defective product or refunding the purchase price of such product.

The warranties set forth in this section shall be of no force or effect with respect to any product: (i) that has been altered or subjected to misuse, negligence or accident, or (ii) that has been used in any manner other than in accordance with the instruction provided by Teledyne Analytical Instruments or (iii) not properly maintained.

THE WARRANTIES SET FORTH IN THIS SECTION AND THE REMEDIES THEREFORE ARE EXCLUSIVE AND IN LIEU OF ANY IMPLIED WARRANTIES OF MERCHANTABILITY, FITNESS FOR PARTICULAR PURPOSE OR OTHER WARRANTY OF QUALITY, WHETHER EXPRESSED OR IMPLIED. THE REMEDIES SET FORTH IN THIS SECTION ARE THE EXCLUSIVE REMEDIES FOR BREACH OF ANY WARRANTY CONTAINED HEREIN. Teledyne Analytical Instruments SHALL NOT BE LIABLE FOR ANY INCIDENTAL OR CONSEQUENTIAL DAMAGES ARISING OUT OF OR RELATED TO THIS AGREEMENT OF Teledyne Analytical Instruments PERFORMANCE HEREUNDER, WHETHER FOR BREACH OF WARRANTY OR OTHERWISE.

Terms and Conditions

All units or components returned to Teledyne Analytical Instruments should be properly packed for handling and returned freight prepaid to the nearest designated Service Center. After the repair, the equipment will be returned, freight prepaid.

User Notes:

3. GETTING STARTED

3.1. UNPACKING AND INITIAL SETUP

**CAUTION**

To avoid personal injury, always use two persons to lift and carry the Model 6400E.

1. Inspect the received packages for external shipping damage. If damaged, please advise the shipper first, then TAI.
2. Included with your analyzer is a printed record (Form number 04551) of the final performance characterization performed on your instrument at the factory. This record is an important quality assurance and calibration record for this instrument. It should be placed in the quality records file for this instrument.
3. Carefully remove the top cover of the analyzer and check for internal shipping damage.
 - Remove the set screw located in the top, center of the rear panel
 - Remove the screws fastening the top cover to the unit (four per side).
 - Lift the cover straight up.

NOTE

Printed circuit assemblies (PCAs) are sensitive to electro-static discharges too small to be felt by the human nervous system. Failure to use ESD protection when working with electronic assemblies will void the instrument warranty.

See Chapter 12 for more information on preventing ESD damage.

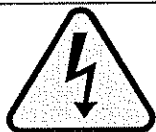
**CAUTION**

Never disconnect electronic circuit boards, wiring harnesses or electronic subassemblies while the unit is under power.

4. Inspect the interior of the instrument to make sure all circuit boards and other components are in good shape and properly seated.
5. Check the connectors of the various internal wiring harnesses and pneumatic hoses to make sure they are firmly and properly seated.
6. Verify that all of the optional hardware ordered with the unit has been installed. These are checked on the paperwork (Form 04551) accompanying the analyzer.

VENTILATION CLEARANCE: Whether the analyzer is set up on a bench or installed into an instrument rack, be sure to leave sufficient ventilation clearance.

AREA	MINIMUM REQUIRED CLEARANCE
Back of the instrument	10 cm / 4 inches
Sides of the instrument	2.5 cm / 1 inch
Above and below the instrument.	2.5 cm / 1 inch

- Various rack mount kits are available for this analyzer. See Chapter 5 of this manual for more information.

3.1.1. ELECTRICAL CONNECTIONS:

	<p>CAUTION</p> <p>Check the voltage and frequency label on the rear panel of the instrument (See Figure 3-1) for compatibility with the local power before plugging the 6400E into line power.</p> <p>Do not plug in the power cord if the voltage or frequency is incorrect.</p>
---	--

	<p>CAUTION</p> <p>Power connection must have functioning ground connection.</p> <p>Do not defeat the ground wire on power plug.</p> <p>Turn off analyzer power before disconnecting or connecting electrical subassemblies.</p> <p>Do not operate with cover off.</p>
---	--

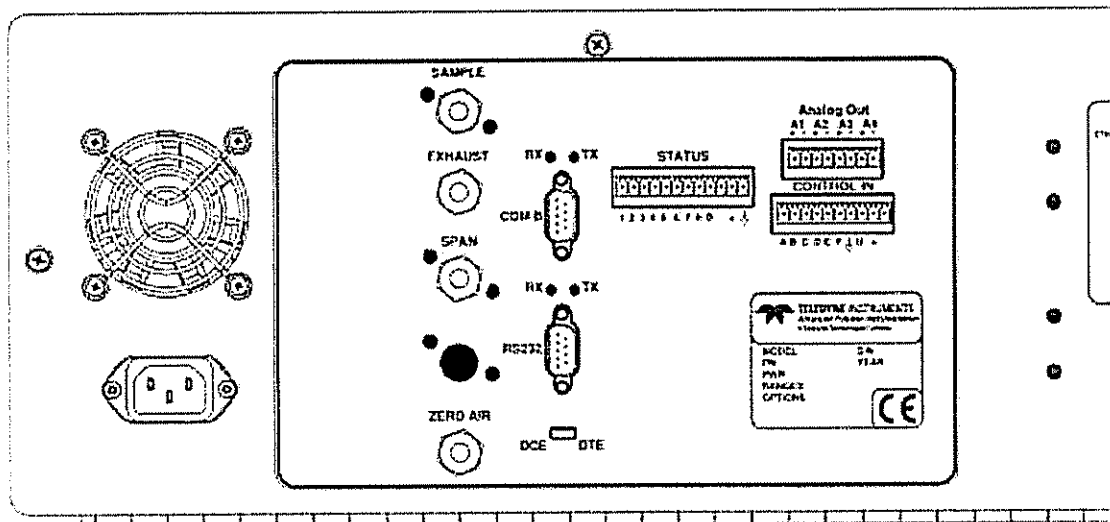

Figure 3-1: Rear Panel Layout

3.1.1.1. Connecting the Analog Outputs

Attach a strip chart recorder and/or data-logger to the appropriate contacts of the analog output connector on the rear panel of the analyzer.

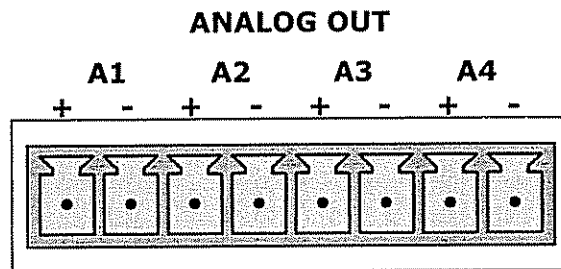

Figure 3-2: Analog Output Connector

The **A1** and **A2** channels output a signal that is proportional to the SO₂ concentration of the sample gas.

The output, labeled **A3** is special. It can be set by the user (see Section 6.9.10) to output any one of the parameters accessible through the <TST TST> keys of the units sample display.

Pin-outs for the Analog Output connector at the rear panel of the instrument are:

Table 3-1: Analog output Pin Outs

PIN	ANALOG OUTPUT	VOLTAGE OUTPUT	CURRENT LOOP OPTION
1	A1	V Out	I Out +
2		Ground	I Out -
3	A2	V Out	I Out +
4		Ground	I Out -
5	A3	V Out	I Out +
6		Ground	I Out -
7	A4	Not Available	Not Available
8		Not Available	Not Available

- The default analog output voltage setting of the 6400E UV Fluorescence SO₂ Analyzer is 0 – 5 VDC.
- TO change these settings, see Sections 6.9.4.1.

An optional Current Loop output is available for each (See Section 5.2).

3.1.1.2. Connecting the Status Outputs

The analyzer’s status outputs are accessed through a 12 pin connector on the analyzer’s rear panel labeled STATUS. They are used to interface with a device that accepts closed-contact digital inputs, such as programmable logic controllers (PLC’s).

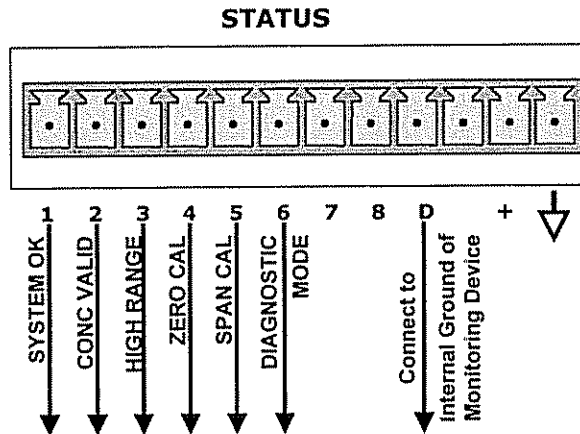

Figure 3-3: Status Output Connector

NOTE

Most PLC’s have internal provisions for limiting the current the input will draw. When connecting to a unit that does not have this feature, external resistors must be used to limit the current through the individual transistor outputs to $\leq 50\text{mA}$ ($120\ \Omega$ for 5V supply).

Table 3-2: Status Output Signals

REAR PANEL LABEL	STATUS DEFINITION	CONDITION
1	SYSTEM OK	ON if no faults are present.
2	CONC VALID	OFF any time the HOLD OFF feature is active, such as during calibration or when other faults exist possibly invalidating the current concentration measurement (example: sample flow rate is outside of acceptable limits). ON if concentration measurement is valid.
3	HIGH RANGE	ON if unit is in high range of the AUTO Range Mode
4	ZERO CAL	ON whenever the instrument’s ZERO point is being calibrated.
5	SPAN CAL	ON whenever the instrument’s SPAN point is being calibrated.
6	DIAG MODE	ON whenever the instrument is in DIAGNOSTIC mode
7 - 8	SPARE	
D	EMITTER BUS	The emitters of the transistors on pins 1-8 are bussed together.
	SPARE	
+	DC POWER	+ 5 VDC, 300 mA source (combined rating with Control Output, if used).
	Digital Ground	The ground level from the analyzer’s internal DC power supplies

3.1.1.3. Connecting the Control Inputs

If you wish to use the analyzer to remotely activate the zero and span calibration modes, several digital control inputs are provided through a 10-pin connector labeled CONTROL IN on the analyzer's rear panel.

There are two methods for energizing the control inputs. The internal +5V available from the pin labeled "+" is the most convenient method. However, if full isolation is required, an external 5 VDC power supply should be used.

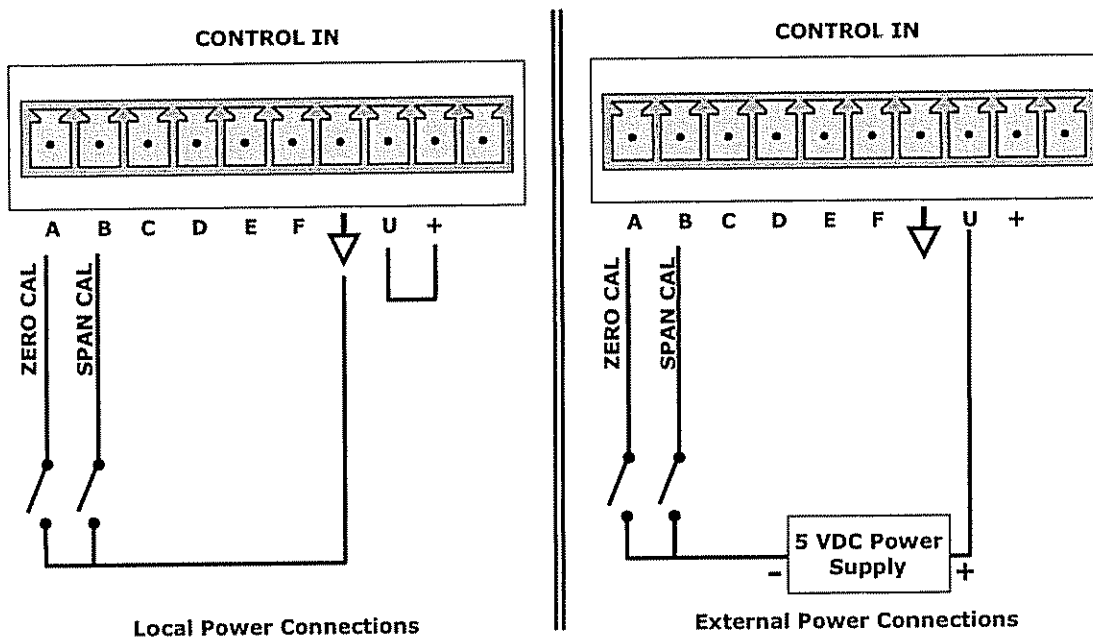

Figure 3-4: Control Input Connector

Table 3-3: Control Input Signals

INPUT #	STATUS DEFINITION	ON CONDITION
A	REMOTE ZERO CAL	The analyzer is placed in Zero Calibration mode. The mode field of the display will read ZERO CAL R.
B	REMOTE SPAN CAL	The analyzer is placed in span calibration mode as part of performing a low span (midpoint) calibration. The mode field of the display will read LO CAL R.
C, D, E & F	SPARE	
⏚	Digital Ground	The ground level from the analyzer's internal DC power supplies (same as chassis ground)
U	External Power input	Input pin for +5 VDC required to activate pins A - F.
+	5 VDC output	Internally generated 5V DC power. To activate inputs A - F, place a jumper between this pin and the "U" pin. The maximum amperage through this port is 300 mA (combined with the analog output supply, if used).

3.1.1.4. Connecting the Serial Ports

If you wish to utilize either of the analyzer's two serial interfaces, refer to Section 6.10 and 6.12 of this manual for instructions on configuration and usage.

3.1.1.5. Connecting to a LAN or the Internet

If your unit has a Teledyne Instruments Ethernet card (Option 63), plug one end of the 7' CAT5 cable supplied with the option into the appropriate place on the back of the analyzer (see Figure 5-6 in Section 5.5.3) and the other end into any nearby Ethernet access port.

3.1.1.6. Connecting to a Multidrop Network

If your unit has a Teledyne Instruments RS-232 multidrop card (Option 62), see Section 6.10.7 for instructions on setting it up.

CAUTION

To prevent dust from getting into the analyzer, it was shipped with small plugs inserted into each of the pneumatic fittings on the rear panel. Make sure that all dust plugs are removed before attaching exhaust and supply gas lines.

3.1.2. PNEUMATIC CONNECTIONS:

NOTE

To prevent dust from getting into the analyzer, it was shipped with small plugs inserted into each of the pneumatic fittings on the rear panel. Make sure that all dust plugs are removed before attaching exhaust and supply gas lines.

Table 3-4: Inlet / Outlet Connector Nomenclature

REAR PANEL LABEL	FUNCTION
Sample	Connects the sample gas to the analyzer. When operating the analyzer without zero span option, this is also the inlet for any calibration gases.
Exhaust	Connect an exhaust gas line to this port vented outside the shelter or immediate area surrounding the instrument.
Zero Air	On Units with zero/span valve or IZS option installed, this port connects the zero air gas or the zero air cartridge to the analyzer.

Figure 3-5 shows the internal pneumatic flow of the 6400E in its Standard configuration. For information on instruments in which one of the various zero/span valve options see Figures 5-2 and 5-3. Refer to these diagrams whenever trouble-shooting or a thorough understanding of the analyzer performance are required.

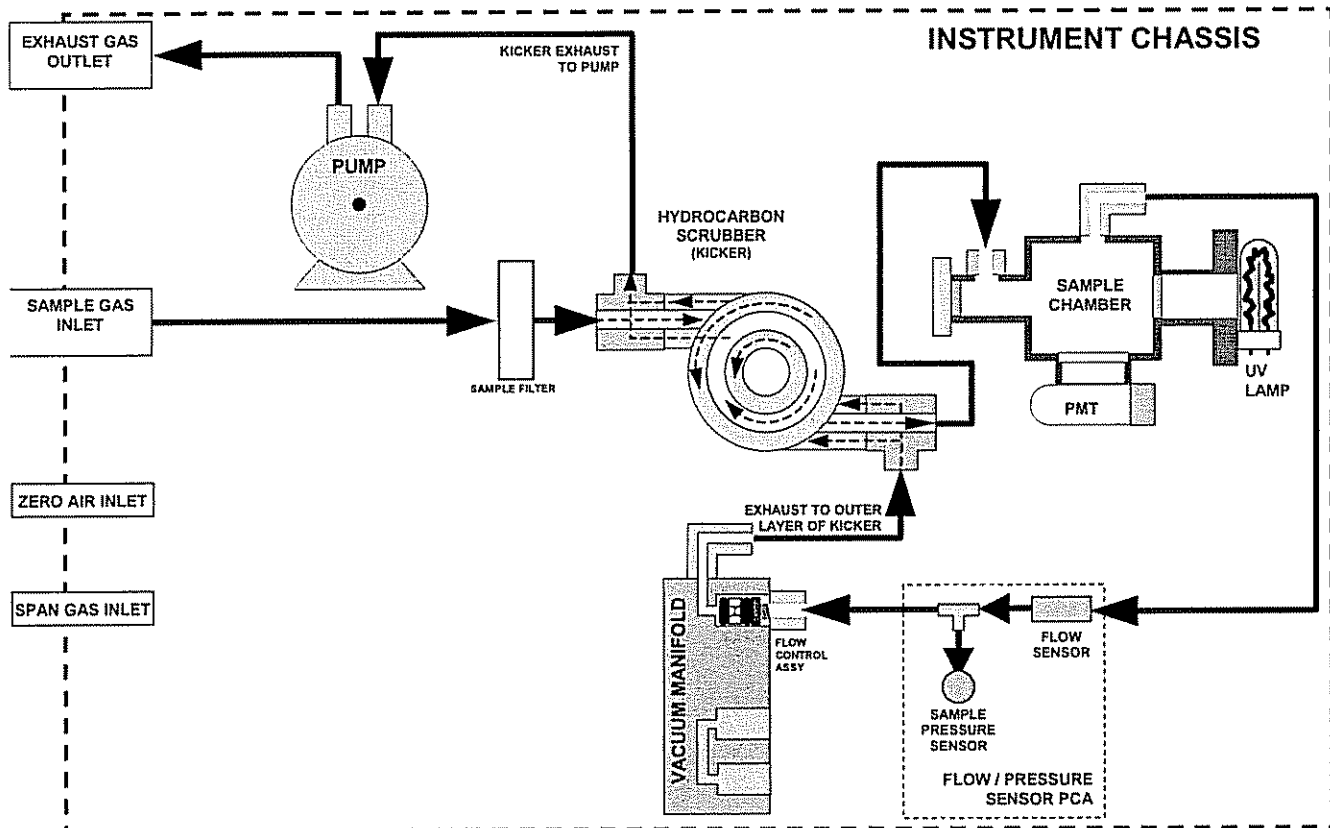

Figure 3-5: Internal Pneumatic Diagram of the 6400E Standard Configuration.**3.1.2.1. Calibration Gases****ZERO AIR**

A gas that is similar in chemical composition to the earth's atmosphere but without the gas being measured by the analyzer, in this case SO₂. If your analyzer is equipped with an IZS or external zero air scrubber option, it is capable of creating zero air.

For analyzers without an IZS or external zero air scrubber option, a zero air generator such as the Teledyne Instruments Model 701 can be used.

SPAN GAS

A gas specifically mixed to match the chemical composition of the type of gas being measured at near full scale of the desired measurement range. In this case, SO₂ measurements made with the Teledyne Analytical Instruments Model 6400E UV Fluorescence SO₂ Analyzer, it is recommended that you use a span gas with a SO₂ concentration equal to 90% of the measurement range for your application.

EXAMPLE: If the application is to measure between 0 ppm and 500 ppb, an appropriate span gas concentration would be 450 ppb SO₂.

Cylinders of calibrated SO₂ gas traceable to NIST-Standard Reference Material specifications (also referred to as SRM's or EPA protocol calibration gases) are commercially available. Table 3-5 lists specific NIST-SRM reference numbers for various concentrations of SO₂.

Some applications, such as EPA monitoring, require a multipoint calibration procedure where span gases of different concentrations are needed. We recommend using a bottle of calibrated SO₂ gas of higher concentration in conjunction with a gas dilution calibrator such as a Teledyne Analytical Instruments Model 700. This type of calibrator precisely mixes a high concentration gas from with zero air (both supplied externally) to accurately produce span gas of the correct concentration. Linearity profiles can be automated with this model and run unattended over night.

Table 3-5: NIST-SRM's Available for Traceability of SO₂ Calibration Gases

NIST-SRM ⁴	TYPE	NOMINAL CONCENTRATION
1693a	Sulfur dioxide in N ₂	50 ppm
1694a	Sulfur dioxide in N ₂	100 ppm
1661a	Sulfur dioxide in N ₂	500 ppm

3.1.2.2. Pneumatic Connections to 6400E Basic Configuration:

Figures 3-5 and 3-6 show the most common configurations for gas supply and exhaust lines to the Model 6400E Analyzer. Please refer to Figure 3-1 for the locations of pneumatic connections on the rear panel and Table 3-4 for nomenclature.

NOTE

Sample and calibration gases should only come into contact with PTFE (Teflon) or glass or materials. They should not come in contact with FEP or stainless steel materials.

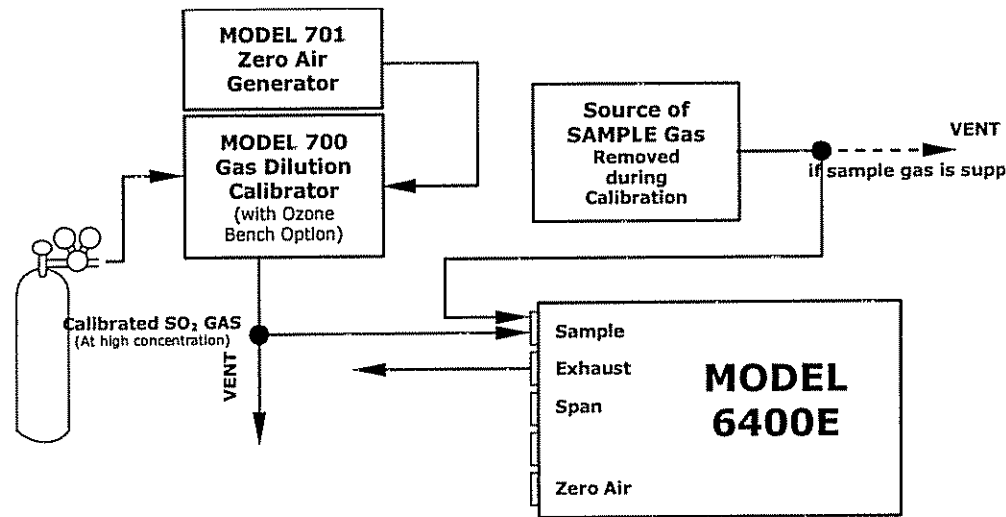

Figure 3-6: Pneumatic Connections--Basic Configuration--Using Gas Dilution Calibrator

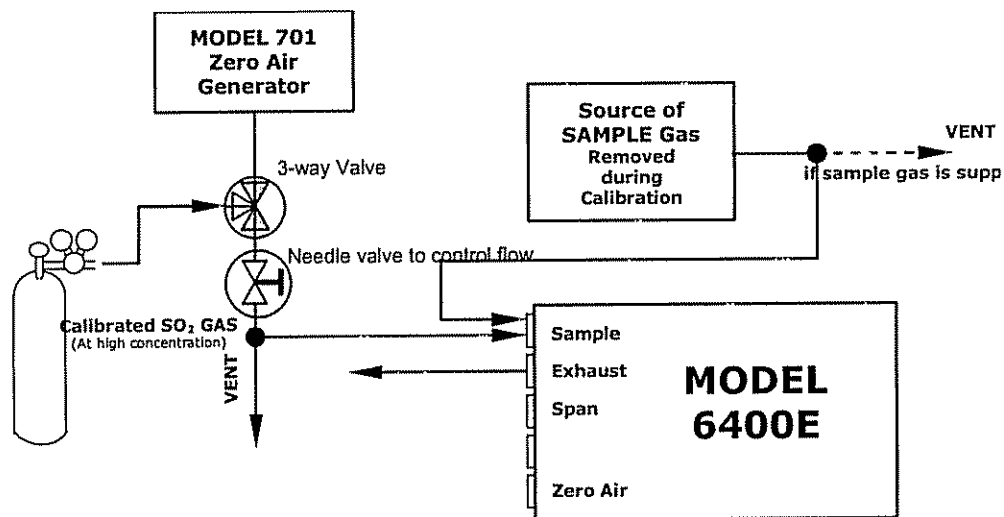

Figure 3-7: Pneumatic Connections--Basic Configuration--Using Bottled Span Gas

1. Attach the 1/4" exhaust line to the exhaust port of the analyzer.

**CAUTION**

The exhaust from the analyzer needs to be vented outside the shelter or immediate area surrounding the instrument and conform to all safety requirements using a maximum of 10 meters of 1/4" PTFE tubing.

2. Attach the sample line to the sample inlet port. Ideally, the pressure of the sample gas should be equal to ambient atmospheric pressure.

NOTE

Maximum pressure of any gas at the sample inlet should not exceed 1.5 in-Hg above ambient pressure and ideally should equal ambient atmospheric pressure.

In applications where the sample gas is received from a pressurized manifold, a vent must be provided to equalize the sample gas with ambient atmospheric pressure before it enters the analyzer. The vented gas needs to be routed outside the immediate area or shelter surrounding the instrument.

3. Attach zero air and span gas supply lines as appropriate (see Figures 3-6, 3-7 & 3.8). For this type of analyzer, zero air and span gas are defined in Section 3.1.2.1.

NOTE:

US EPA requirements state that zero air and span gases be supplied at twice the instrument's specified gas flow rate.

Therefore for the 6400E zero and span gasses should be supply to their respective inlets in excess of 1300 cc³/min (650 cc³/min. x 2).

Supply and vent lines should be of sufficient length and diameter to prevent back diffusion and pressure effects.

4. Once the appropriate pneumatic connections have been made, check all pneumatic fittings for leaks using a procedure similar to that defined in Section 11.5.1.

3.1.2.3. Connections with Internal Valve Options Installed

If your analyzer is equipped with either the zero/span valve option (Option 50) or the internal zero/span option (Option 51), the pneumatic connections should be made as follows:

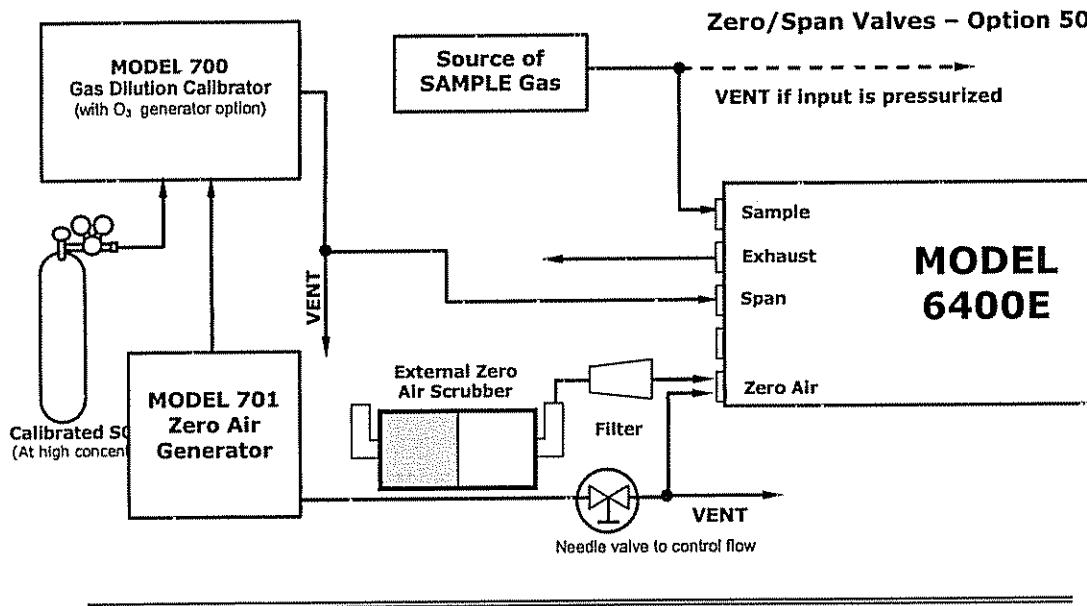

Internal Zero/Span Option (IZS) – Option 51

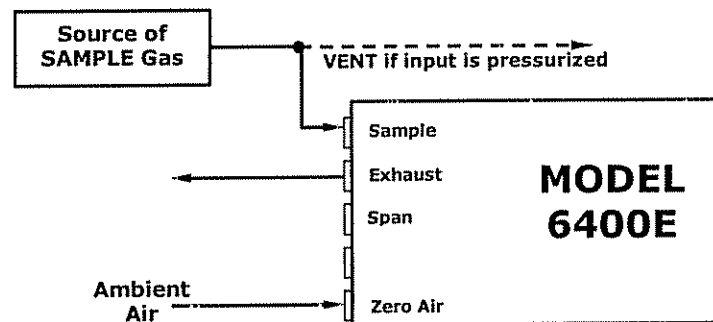

Figure 3-8: Basic Pneumatic Connections for Units with Valve Options

Caution

Gas flow must be maintained at all times for units with IZS Options installed. The IZS option includes a permeation tube which emits SO₂. Insufficient gas flow can build up SO₂ to levels that will damage the instrument.

Remove the permeation device when taking the analyzer out of operation.

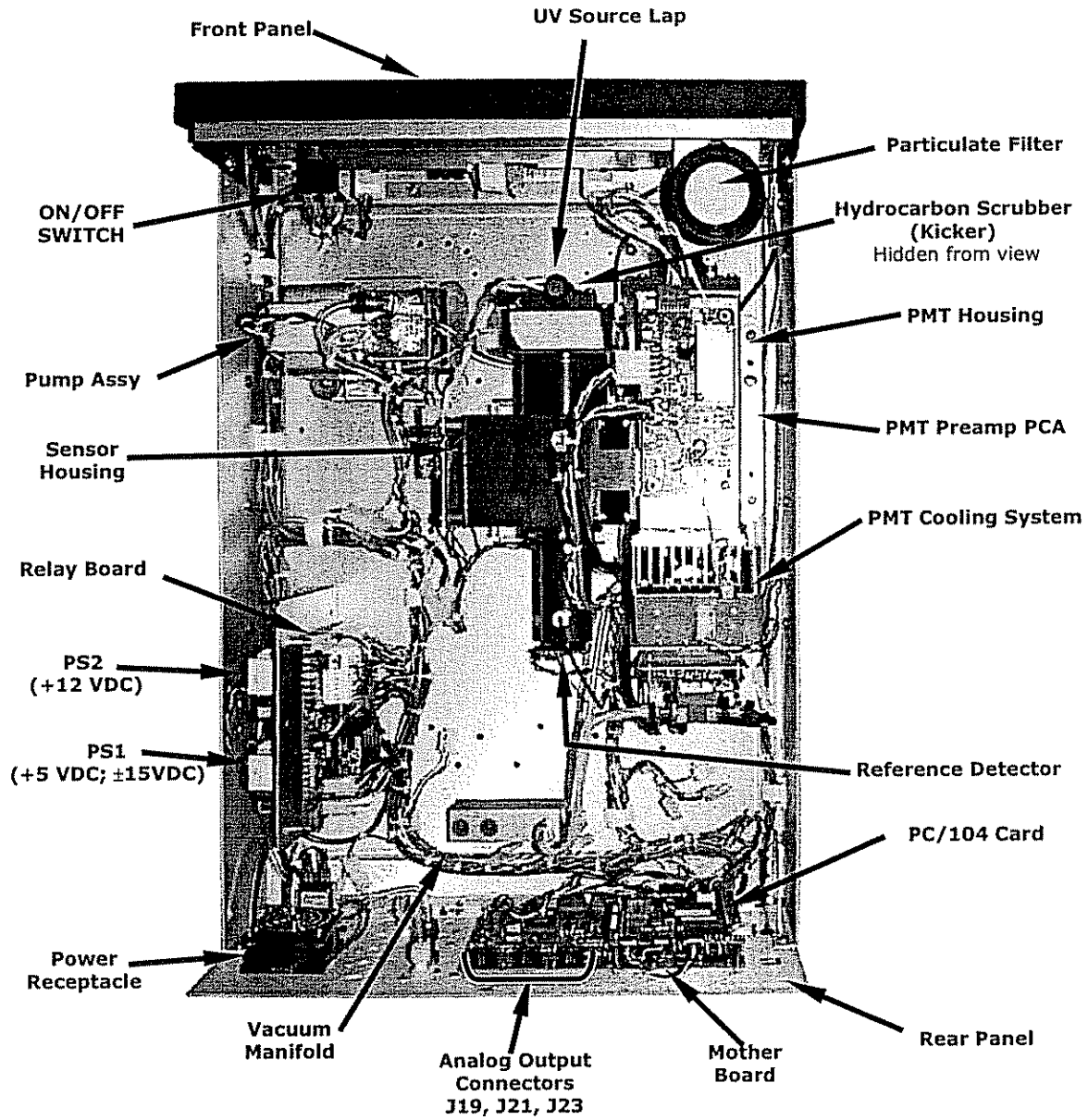



Figure 3-9: 6400E Layout (Basic Unit – No Valve Options)

3.2. INITIAL OPERATION

	<p>CAUTION</p> <p>Do not look at the UV lamp while the unit is operating. UV light can cause eye damage.</p> <p>Always use safety glasses (plastic glasses will not do).</p>
---	---

If you are unfamiliar with the 6400E theory of operation, we recommend that you read Chapter 10 before proceeding. For information on navigating the analyzer's software menus, see the menu trees described in Appendix A.1.

3.2.1. STARTUP

After electrical and pneumatic connections are made, turn on the instrument. The exhaust and PMT cooler fans should start. The display should immediately display a single, horizontal dash in the upper left corner of the display. This will last approximately 30 seconds while the CPU loads the operating system.

Once the CPU has completed this activity it will begin loading the analyzer firmware and configuration data. During this process, string of messages will appear on the analyzer's front panel display:

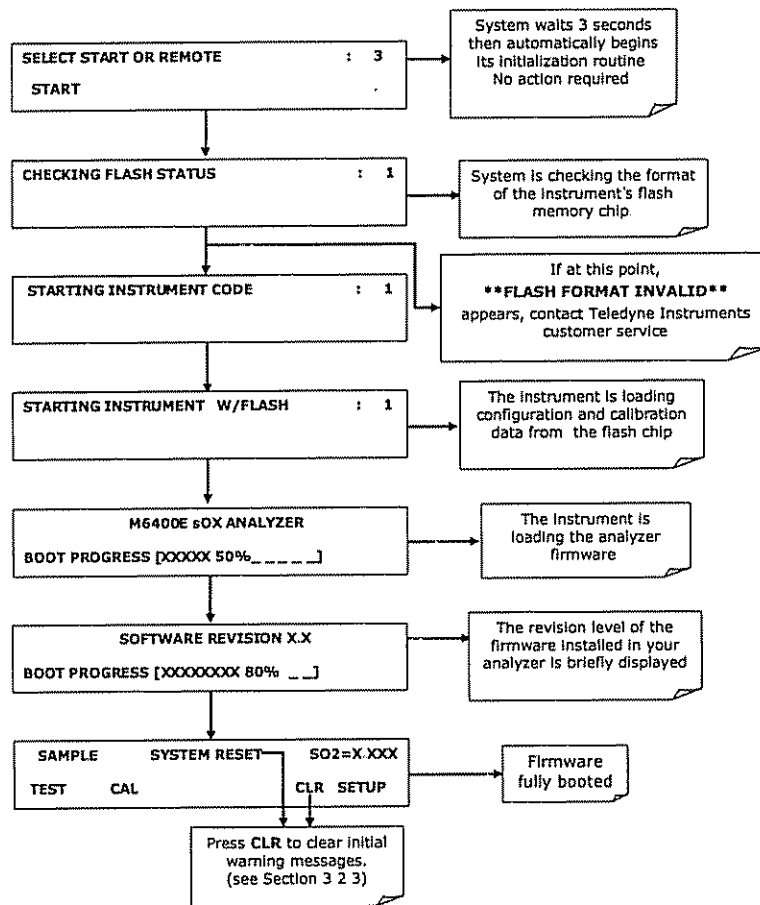

The analyzer should automatically switch to **SAMPLE** mode after completing the boot-up sequence and start monitoring SO₂ gas.

3.2.2. WARM-UP

The 6400E requires about 60 minutes warm-up time before reliable SO₂ measurements can be taken. During that time, various portions of the instrument's front panel will behave as follows. See Figure 3-10 for locations.

Table 3-6: Front Panel Display During System Warm-Up

NAME	COLOR	BEHAVIOR	SIGNIFICANCE
Concentration Field	N/A	Displays current, compensated SO ₂ Concentration	N/A
Mode Field	N/A	Displays blinking "SAMPLE"	Instrument is in sample mode but is still in the process of warming up.
STATUS LED'S			
Sample	Green	Blinking ON	iDAS holdoff feature (see Table 6-8) is active the first 15 minutes after startup. Unit is operating in sample mode, front panel display is being updated.
Cal	Yellow	Off	The instrument's calibration is not enabled.
Fault	Red	Blinking	The analyzer is warming up and hence out of specification for a fault-free reading. various warning messages will appear.

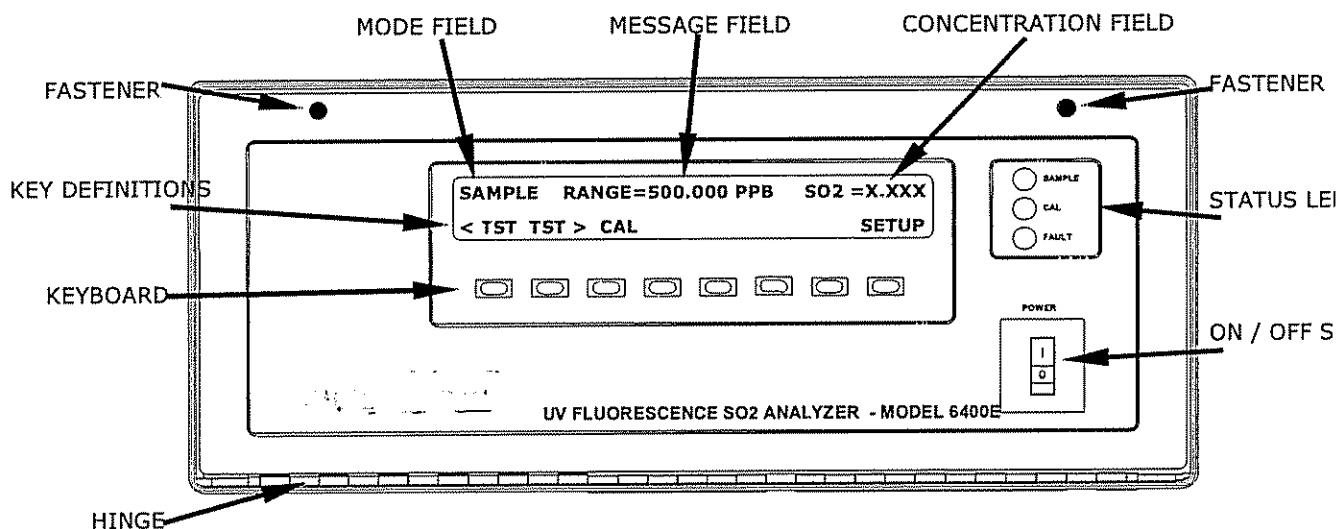

Figure 3-10: Front Panel Layout

3.2.3. WARNING MESSAGES

Because internal temperatures and other conditions may be outside of specified limits during the analyzer's warm-up period, the software will suppress most warning conditions for 60 minutes after power up.

If warning messages persist after 60 minutes, investigate their cause using the troubleshooting guidelines in Chapter 11. The following table includes a brief description of the various warning messages that may appear.

Table 3-7: Possible Warning Messages at Start-Up

MESSAGE	MEANING
ANALOG CAL WARNING	The instruments internal A-to-D circuitry (also referred to as "Analog In"; see Table 6-6) or one of its analog outputs is not calibrated.
BOX TEMP WARNING	The temperature inside the 6400E chassis is outside the specified limits.
CANNOT DYN SPAN	Remote span calibration failed while the dynamic span feature was set to turned on
CANNOT DYN ZERO	Remote zero calibration failed while the dynamic zero feature was set to turned on
CONFIG INITIALIZED	Configuration was reset to factory defaults or was erased.
DARK CAL WARNING	Dark offset above limit specified indicating that too much stray light is present in the sample chamber.
DATA INITIALIZED	iDAS data storage was erased.
FRONT PANEL WARN	Firmware is unable to communicate with the front panel.
HVPS WARNING	High voltage power supply for the PMT is outside of specified limits.
IZS TEMP WARNING	On units with IZS options installed: The permeation tube temperature is outside of specified limits.
PMT DET WARNING	PMT detector output outside of operational limits.
PMT TEMP WARNING	PMT temperature is outside of specified limits.
RCELL TEMP WARNING	Sample chamber temperature is outside of specified limits.
REAR BOARD NOT DET	The CPU is unable to communicate with the motherboard.
RELAY BOARD WARN	The firmware is unable to communicate with the relay board.
SAMPLE FLOW WARN	The flow rate of the sample gas is outside the specified limits.
SAMPLE PRESS WARN	Sample pressure outside of operational parameters.
SYSTEM RESET	The computer was rebooted.
UV LAMP WARNING	The UV lamp intensity measured by the reference detector reading too low or too high.

NOTE: See TABLE 11.1 for a more detailed lists of possible causes of the above warning messages.

To view and clear warning messages:

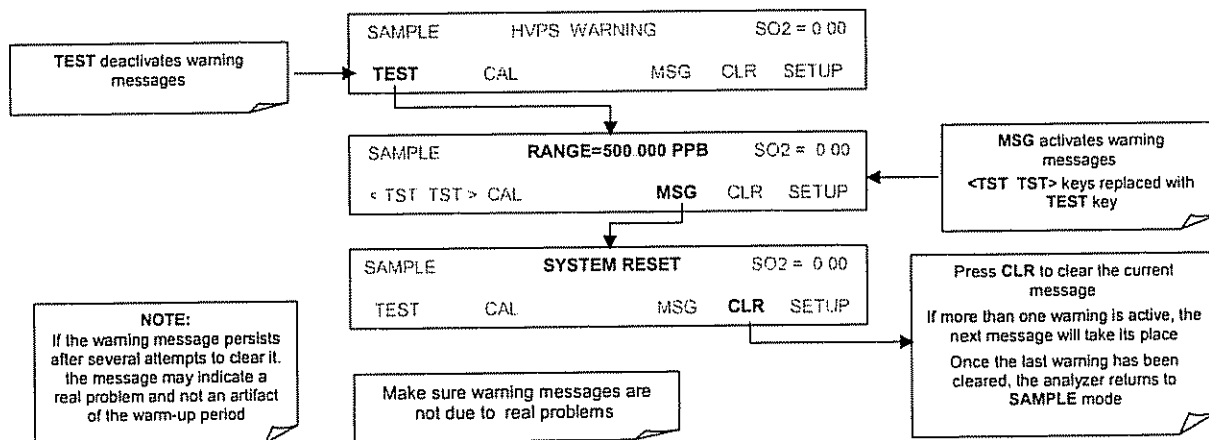

3.2.4. FUNCTIONAL CHECK

1. After the analyzer's components have warmed up for at least 60 minutes, verify that the software properly supports any hardware options that were installed.
2. Check to make sure that the analyzer is functioning within allowable operating parameters. Appendix C includes a list of test functions viewable from the analyzer's front panel as well as their expected values. These functions are also useful tools for diagnosing performance problems with your analyzer (see Section 11.1.2). The enclosed Final Test and Validation Data sheet (part number 04551) lists these values before the instrument left the factory.

To view the current values of these parameters press the following key sequence on the analyzer's front panel. Remember until the unit has completed its warm up these parameters may not have stabilized.

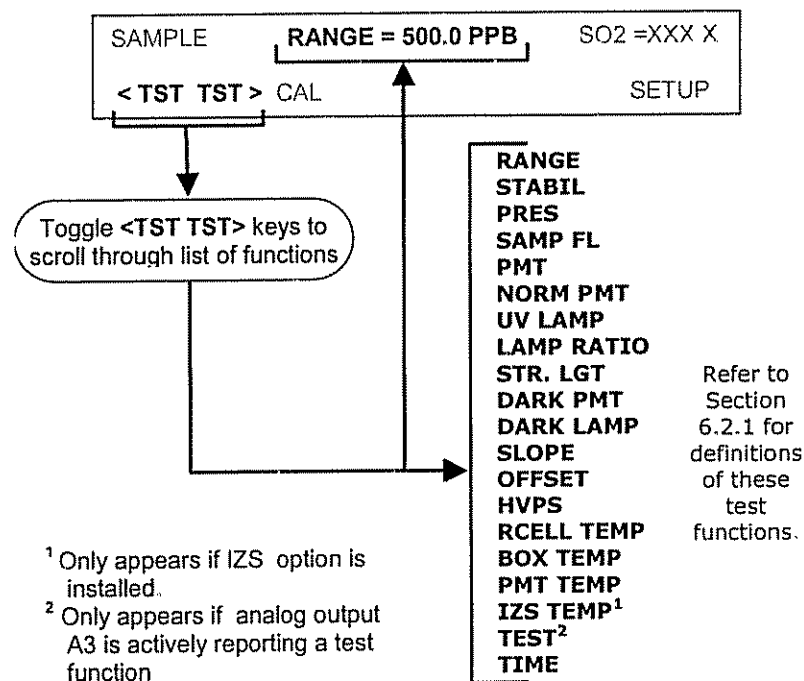

3. If your analyzer has an Ethernet card (Option 63) installed and your network is running a dynamic host configuration protocol (DHCP) software package, the Ethernet option will automatically configure its interface with your LAN. However, it is a good idea to check these settings to make sure that the DHCP has successfully downloaded the appropriate network settings from your network server (See Section 6.10.6.2).

If your network is not running DHCP, you will have to configure the analyzer's interface manually (See Section 6.10.6.3).

NOTE

Once you have completed the above set-up procedures, please fill out the Quality Questionnaire that was shipped with your unit and return it to Teledyne Analytical Instruments.

This information is vital to our efforts in continuously improving our service and our products.

THANK YOU.

3.3. INITIAL CALIBRATION

3.3.1. BASIC CALIBRATION PROCEDURE

The following three-step procedure assumes that the instrument does not have any of the available zero/span (Z/S) or IZS valve options installed. Chapter 7 contains instructions for calibrating instruments with valve options. Chapter 8 contains directions for performing for EPA protocol calibrations.

The initial calibration should be carried out with the analyzer's reporting range for **SINGLE** range mode with a range span of **500 PPB** (factory default settings for most units). This will enable you to compare your results to the factory calibration.

STEP ONE: Set/verify the analog output reporting range of the 6400E:

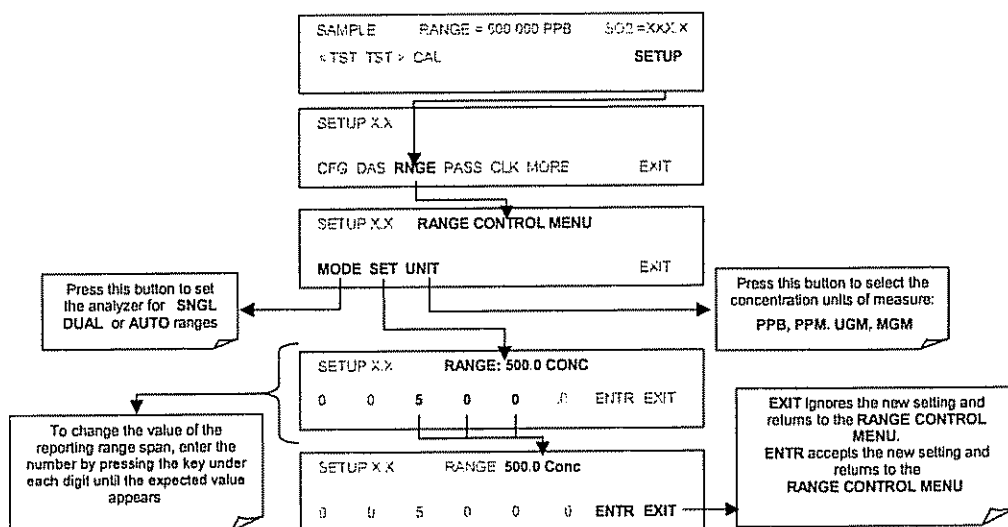

STEP TWO: Set the expected SO₂ span gas concentration.

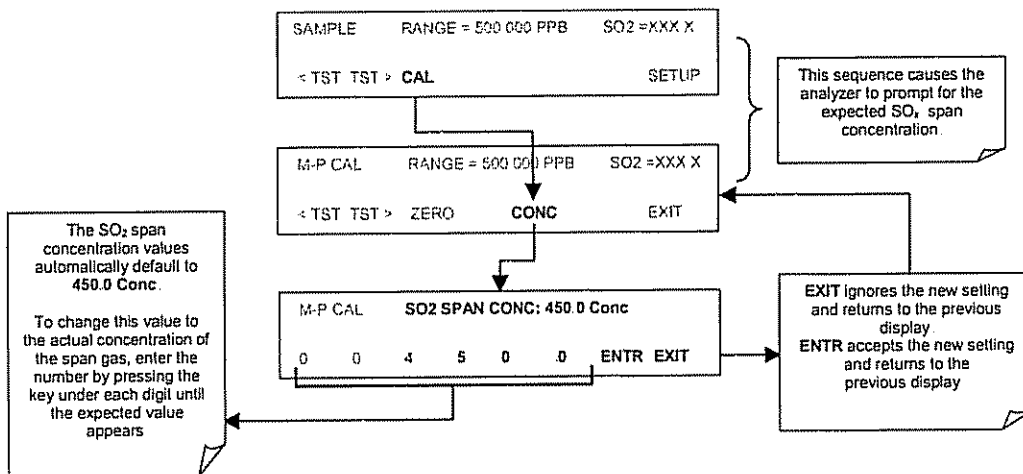

STEP THREE: Perform the zero/span calibration procedure:

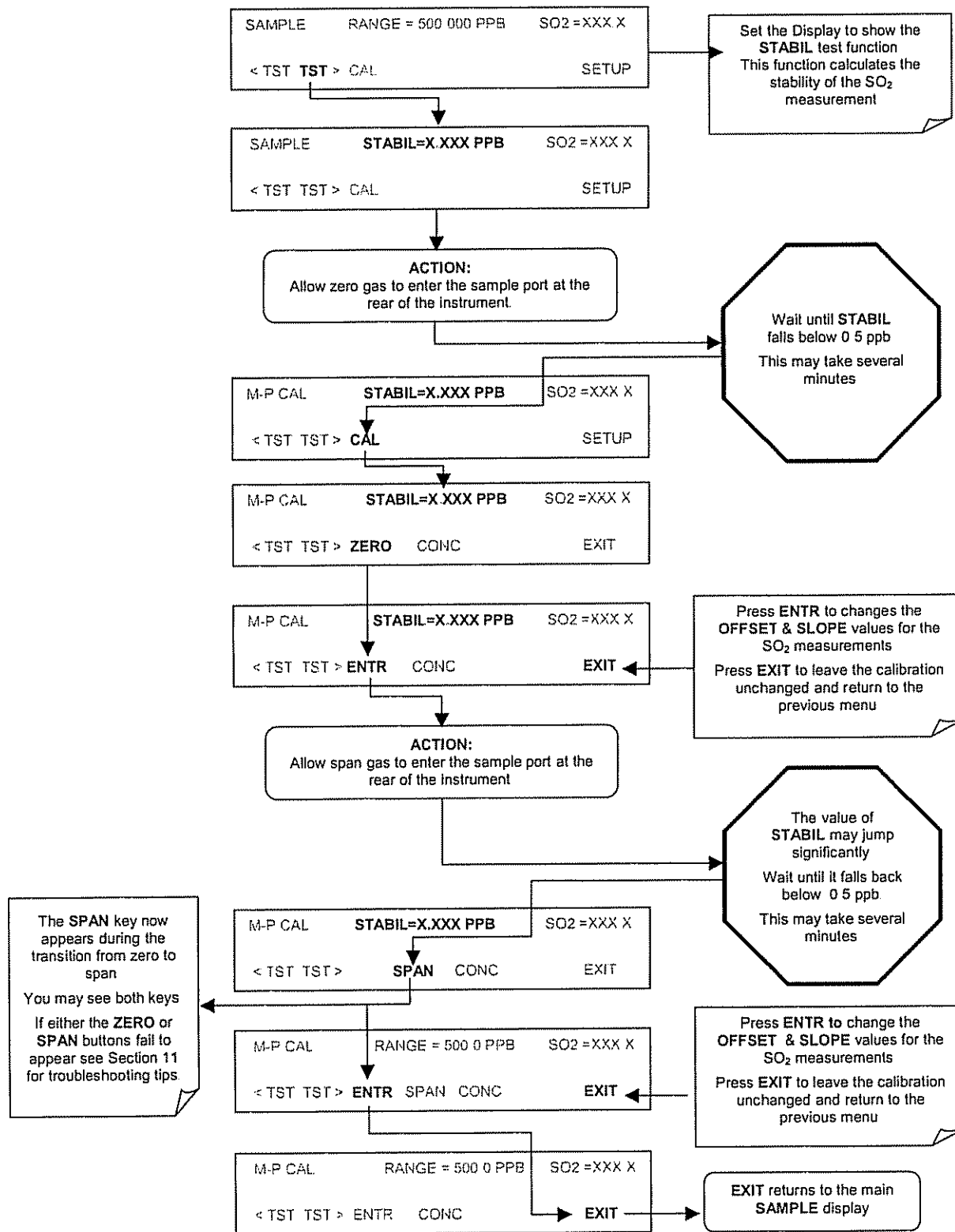

Check the value of the **SLOPE** and **OFFSET** test functions (see Section 6.2.1) to verify that they are within the limits listed in Table 7-5)

The Model 6400E analyzer is now ready for operation.

3.3.2. INTERFERENCES FOR SO₂ MEASUREMENTS

It should be noted that the fluorescence method for detecting SO₂ is subject to interference from a number of sources. The most common source of interference is from other gases that fluoresce in a similar fashion to SO₂ when exposed to UV Light such as nitrogen oxide (NO) and polynuclear aromatics (PNA), of which certain hydrocarbons such as meta-xylene and naphthalene are the most pervasive. The 6400E has been successfully tested for its ability to reject interference from most of these sources.

For a more detailed discussion of this topic, see Section 10.2.7.

User Notes:

4. FREQUENTLY ASKED QUESTIONS & GLOSSARY

4.1. FAQ'S

The following list contains some of the most commonly asked questions relating to the Model 6400E SO₂ Analyzer.

Q: Why is the **ZERO** or **SPAN** key not displayed during calibration?

A: The 6400E disables certain keys whenever the chosen value is out of range for that particular parameter. In this case, the expected span or zero value is too different from the actually measured value and the instrument does not allow to span or zero to that point. Chapter 11 describes this in detail.

Q: Why does the **ENTR** key sometimes disappear on the front panel display?

A: Sometimes the **ENTR** key will disappear if you select a setting that is invalid or out of the allowable range for that parameter, such as trying to set the 24-hour clock to 25:00:00 or a range to more than 20 000 ppb. Once you adjust the setting to an allowable value, the **ENTR** key will re-appear.

Q: Can I automate the calibration of my analyzer?

A: Any analyzer with zero/span valve or IZS option can be automatically calibrated using the instrument's AutoCal feature.

However, the accuracy of the IZS option's permeation tube is $\pm 5\%$. While this may be acceptable for basic calibration checks, the IZS option is not permitted as a calibration source in applications following US EPA protocols.

To achieve highest accuracy, it is recommended to use cylinders of calibrated span gases in combination with a zero air source. TAI offers a zero air generator Model 701 and a gas dilution calibrator Model 700 for this purpose.

Q: What do I do if the concentration on the instrument's front panel display does not match the value recorded or displayed on my data logger even if both instrument's are properly calibrated?

A: This most commonly occurs for one or both of the following reasons:

- A difference in circuit ground between the analyzer the data logger, or;
- A scale problem with the input to the data logger.

The analog outputs of the analyzer can be manually calibrated to compensate for either or both of these effects, see Section 6.9.4.

Q: How do I measure the sample flow?

A: Sample flow is measured by attaching a calibrated flow meter to the sample inlet port when the instrument is operating. The sample flow should be 650 cm³/min $\pm 10\%$. Chapter 11 includes detailed instructions on performing a check of the sample gas flow.

Q: How often do I need to change the particulate filter?

A: Once per week. Table 9-1 contains a maintenance schedule listing the most important, regular maintenance tasks.

Q: How long does the sample pump last?

A: The sample pump should last about one year and the pump diaphragms should to be replaced annually or when necessary. Use the **PRES** test function displayed via the front panel to see if the diaphragm needs replacement.

Q: Do I need a strip chart recorder or external data logger?

A: No, the 6400E is equipped with a very powerful internal data acquisition system. Section 6.11 describes the setup and operation in detail.

4.2. GLOSSARY

ASSY - acronym for *Assembly*

cm³ - metric abbreviation for *cubic centimeter*. Same as the obsolete abbreviation "cc".

DAS - acronym for *data acquisition system*, the old acronym of IDAS.

DIAG - acronym for *diagnostics*, the diagnostic settings of the analyzer

DHCP: acronym for *dynamic host configuration protocol*. A protocol used by LAN or Internet servers to automatically set up the interface protocols between themselves and any other addressable device connected to the network.

DOC - *Disk On Chip*, the analyzer's central storage area for analyzer firmware, configuration settings and data. This is a solid state device without mechanically moving parts that acts as a computer hard disk drive under → DOS with disk label "C". DOC chips come with 2 mb in the E-series analyzer standard configuration but are available in larger sizes.

DOS - *Disk Operating System*. The E-series analyzers use DR DOS

EEPROM - also referred to as a FLASH chip.

FLASH - flash memory is non-volatile, solid-state memory.

GFC - Acronym for *Gas Filter Correlation*.

I²C bus - a clocked, bi-directional, serial bus for communication between individual analyzer components

IDAS - acronym for *internal data acquisition system*

IP - acronym for *internet protocol*

LAN - acronym for *local area network*

LED - acronym for *light emitting diode*

PCA - acronym for *printed circuit assembly*, the → PCB with electronic components, ready to use.

PCB - acronym for *printed circuit board*, the bare board without electronic components

RS-232 - a type of serial communications port

RS-485 - a type of serial communications port

TCP/IP - acronym for *transfer control protocol / internet protocol*, the standard communications protocol for Ethernet devices.

VARS - acronym for *variables*, the variables settings of the analyzer

USER NOTES:

5. OPTIONAL HARDWARE AND SOFTWARE

This section includes a descriptions of the hardware and software options available for the Model 6400E UV Fluorescence SO₂ Analyzer. For assistance with ordering these options please contact the sales department of Teledyne - Advanced Pollution Instruments at:

TEL: 626-961-2358
 TEL: 626-934-1651
 FAX: 626-934-1531

WEB SITE: <http://www.teledyne-ai.com/>

5.1. RACK MOUNT KITS (OPTIONS 20A, 20B & 21)

There are several options for mounting the analyzer in standard 19" racks.

Option Number	Description
OPT 20A	Rack mount brackets with 26 in. chassis slides.
OPT 20B	Rack mount brackets with 24 in. chassis slides.
OPT 21	Rack mount brackets only

5.2. CURRENT LOOP ANALOG OUTPUTS (OPTION 41)

This option adds isolated, voltage-to-current conversion circuitry to the analyzer's analog outputs. This option may be ordered separately for any of the analog outputs, it can be installed at the factory or added later. Call Teledyne Analytical Instruments sales for pricing and availability.

The current loop option can be configured for any output range between 0 and 20 mA. Information on calibrating or adjusting these outputs can be found in Section 6.9.4.5.

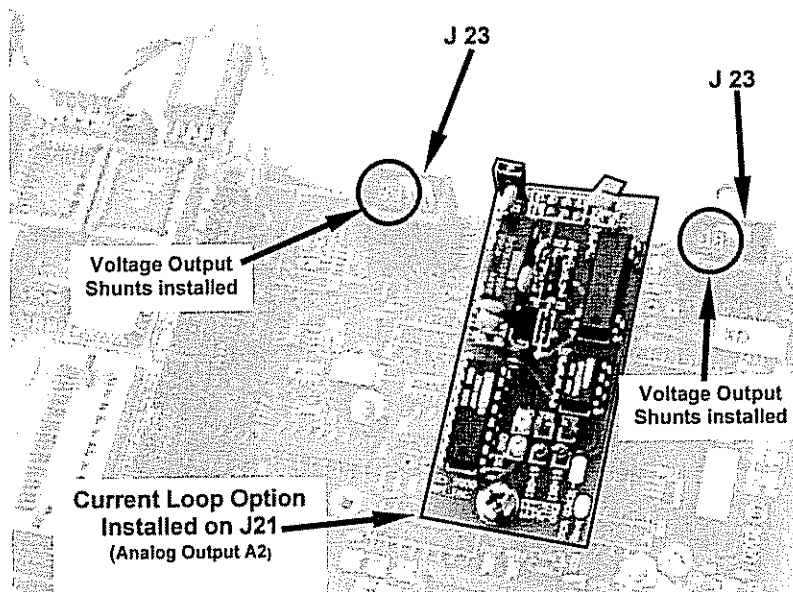

Figure 5-1: Current Loop Option Installed on the Motherboard

5.2.1. CONVERTING CURRENT LOOP ANALOG OUTPUTS TO STANDARD VOLTAGE OUTPUTS.

NOTE

Servicing or handling of circuit components requires electrostatic discharge protection, i.e. ESD grounding straps, mats and containers. Failure to use ESD protection when working with electronic assemblies will void the instrument warranty.

See Chapter 12 for more information on preventing ESD damage.

To convert an output configured for current loop operation to the standard 0 to 5 VDC output operation:

1. Turn off power to the analyzer.
2. If a recording device was connected to the output being modified, disconnect it.
3. Remove the top cover
 - Remove the set screw located in the top, center of the rear panel
 - Remove the screws fastening the top cover to the unit (four per side).
 - Lift the cover straight up.
4. Disconnect the current loop option PCA from the appropriate connector on the motherboard (see Figure 3-9).
5. Place a shunt between the leftmost two pins of the connector (see Figure 5-1).
 - 6 spare shunts (P/N CN0000132) were shipped with the instrument attached to JP1 on the back of the instruments keyboard and display PCA
6. Reattach the top case to the analyzer.
7. The analyzer is now ready to have a voltage-sensing, recording device attached to that output

5.3. PARTICULATE FILTER KIT (OPTION 42A)

This option includes a one-year supply of 50 replacement particulate filters, 47mm in diameter, 1 micrometer pore size.

5.4. CALIBRATION VALVES OPTIONS

5.4.1. ZERO/SPAN VALVES (OPTION 50)

The Model 6400E SO₂ analyzer can be equipped with a zero/span valve option for controlling the flow of calibration gases generated from external sources. This option contains two, sets of Teflon® solenoid valves located inside the analyzer that allow the user to switch either zero, span or sample gas to the instrument's sensor. Figure 5-2 shows the internal, pneumatic connections for a Model 6400E with the zero/span valve option installed.

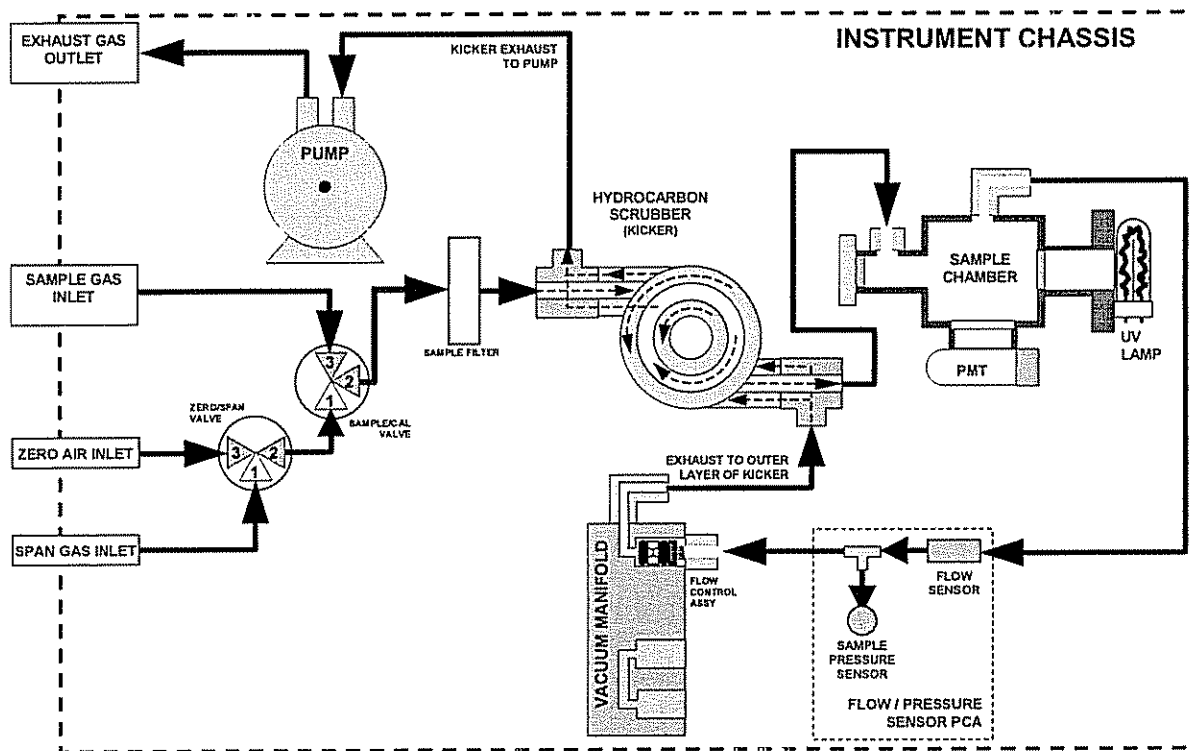

Figure 5-2: Pneumatic Diagram of the 6400E With Z/S Option Installed.

Table 5-1 describes the state of each valve during the analyzer's various operational modes.

Table 5-1: Zero/Span Valve Operating States

MODE	VALVE	CONDITION	VALVE PORT CONNECTION (FIG. 5-2)
SAMPLE	Sample/Cal	Open to SAMPLE inlet	3 → 2
	Zero/Span	Open to ZERO AIR inlet	3 → 2
ZERO CAL	Sample/Cal	Open to zero/span inlet	1 → 2
	Zero/Span	Open to ZERO AIR inlet	3 → 2
SPAN CAL	Sample/Cal	Open to zero/span inlet	1 → 2
	Zero/Span	Open to SPAN GAS inlet	1 → 2

The state of the zero/span valves can also be controlled:

- Manually from the analyzer's front panel by using the **SIGNAL I/O** controls located under the **DIAG** Menu (see Section 6.9.2),
- By activating the instrument's AutoCal feature (see Section 7.8),
- Remotely by using the external digital control inputs (see Section 6.12.1.2 and Section 7.7.1), or
- Remotely through the RS-232/485 serial I/O ports (see Appendix A-6 for the appropriate commands).

Sources of zero and span gas flow must be capable of supplying at least 600 cm³/min. Both supply lines should be vented outside of the analyzer's enclosure. In order to prevent back-diffusion and pressure effects, these vent lines should be between 2 and 10 meters in length.

5.4.2. INTERNAL ZERO/SPAN GAS GENERATOR (OPTION 51)

The 6400E can be equipped with an internal zero air and span gas generator (IZS). This option includes a heated enclosure for a permeation tube, an external scrubber for producing zero air and a set of valves for switching between the sample gas inlet and the output of the zero/span valve option, functionally very similar to the valves included in the zero/span valve option.

Figure 5-3 shows the internal pneumatic connections for a Model 6400E with the IZS option installed. Table 5-2 describes the operational state of the valves associated with the IZS option during the analyzer's various operating modes.

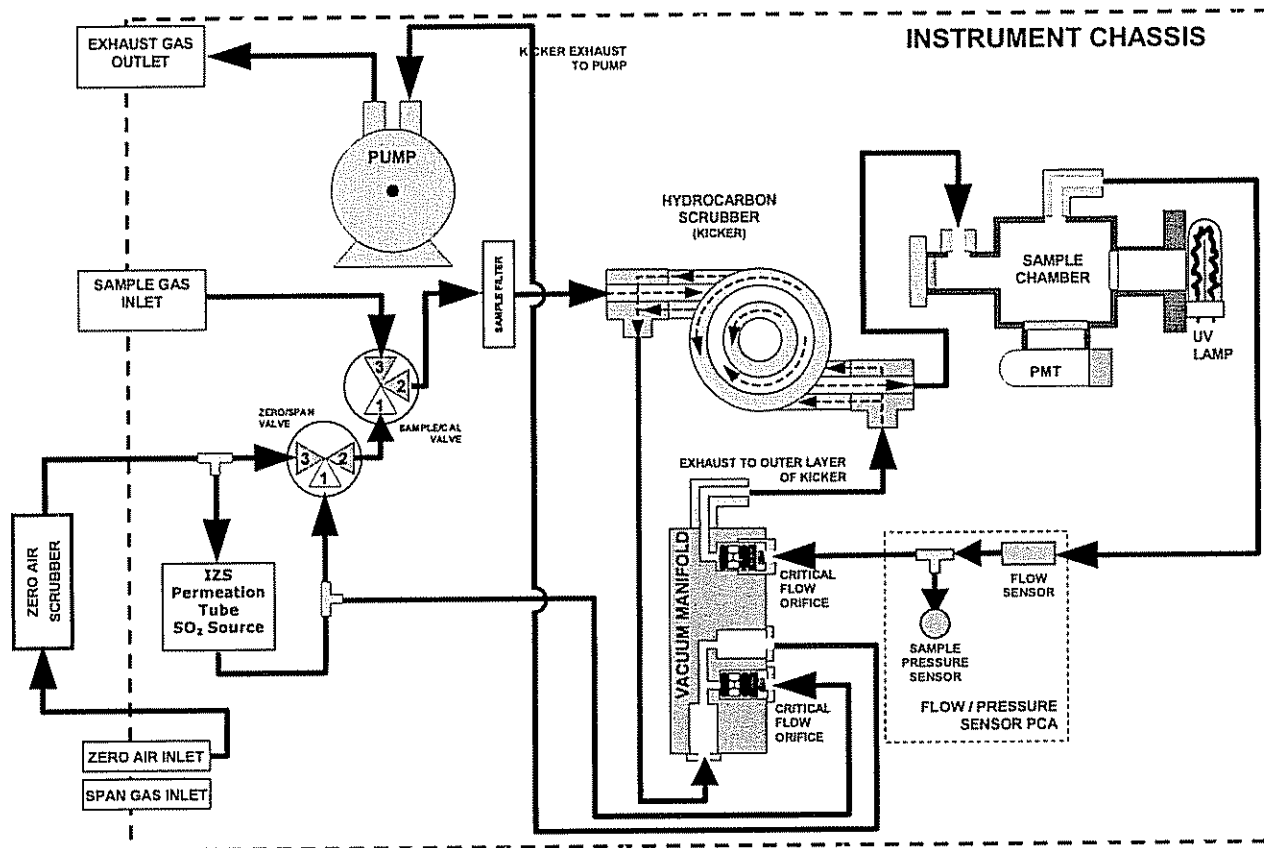

Figure 5-3: Pneumatic Diagram of the 6400E with IZS Options Installed.

Table 5-2: IZS Valve Operating States

MODE	VALVE	CONDITION	VALVE PORT CONNECTIONS (FIG. 5-2)
SAMPLE	Sample/Cal	Open to SAMPLE inlet	3 → 2
	Zero/Span	Open to ZERO AIR inlet	3 → 2
ZERO CAL	Sample/Cal	Open to zero/span valve	1 → 2
	Zero/Span	Open to ZERO AIR inlet	3 → 2
SPAN CAL	Sample/Cal	Open to zero/span valve	1 → 2
	Zero/Span	Open to SPAN GAS inlet	1 → 2

The state of the IZS valves can also be controlled:

- Manually from the analyzer's front panel by using the **SIGNAL I/O** controls located under the **DIAG** Menu (see Section 6.9.2),
- By activating the instrument's AutoCal feature (see Section 7.8),
- Remotely by using the external digital control inputs (see Section 6.12.1.2 and Section 7.7.1), or
- Remotely through the RS-232/485 serial I/O ports (see Appendix A-6 for the appropriate commands).

External Zero Air Scrubber

The IZS option includes an external zero air scrubber assembly that removes all SO₂ the zero air source. The scrubber is filled with activated charcoal.

Span Gas Source

Span gas is created when zero air passes over a permeation tube containing liquid SO₂ under high pressure, which slowly permeates through a PTFE membrane into the surrounding air. The speed at which the SO₂ permeates the membrane is called the effusion rate. The concentration of the span gas is determined by three factors:

- Size of the membrane: The larger the area of the membrane, the more permeation occurs.
- Temperature of the SO₂: Increasing the temperature of the increases the pressure inside the tube and therefore increases the effusion rate.
- Flow rate of the zero air: If the previous two variables are constant, the permeation rate of the into the zero air stream will be constant. Therefore, a lower flow rate of zero air produces higher concentrations of SO₂. The 6400E usually has a constant flow rate and a constant permeation rate, hence, variations in concentration can be achieved by changing the IZS temperature.

NOTE

The permeation tube is not included in the IZS Option and must be ordered separately. See Section 5.4.3 below.

Permeation Tube Heater

In order to keep the permeation rate constant, the IZS enclosure is heated to a constant 50° C (10° above the maximum operating temperature of the instrument). The IZS heater is controlled by a precise PID (Proportional/Integral/Derivative) temperature control loop. A thermistor measures the actual temperature and reports it to the CPU for control feedback.

CAUTION

Gas flow through the analyzer must be maintained at all time for units with a permeation tube installed. Insufficient gas flow allows gas to build up to levels that will contaminate the instrument.

5.4.3. IZS PERMEATION TUBES (OPTIONS 53, 55 & 57)

Several replacement permeation tubes are available for the IZS option. They are identical in size and shape but are designed to have different effusion rates.

OPTION	EFFUSION RATE (± 25%)	APPROXIMATE CONCENTRATION	SPECIFIED FLOW RATE
OPT 53	421 ng/min	300 - 500 ppb	0.76 lpm
OPT 55	842 ng/min	600 - 1000 ppb	0.76 lpm
OPT 57	222 ng/min	800 - 1200 ppb	0.56 lpm

Each tube comes with a calibration certificate, traceable to a NIST standard, specifying its actual effusion rate of that tube to within ±5% when immersed in a gas stream moving at the specified flow rate. This calibration is performed at a tube temperature of 50° C.

5.4.4. ZERO AIR SCRUBBER MAINTENANCE KIT (OPTION 43)

This kit includes the following items needed to refurbish the zero air scrubber, included with the IZS valve options.

TAI PART NO.	DESCRIPTION
00596000E0	Activated charcoal
FL0000001	Sintered filter for span gas inlet fitting ¹
FL0000003	Replacement particulate filter
OR0000001	O-Ring (qty:2) ¹

5.5. COMMUNICATION OPTIONS

5.5.1. RS232 MODEM CABLE (OPTION 60)

This option consists of a cable to connect the analyzer's COM1 port to a computer, a code activated switch or any other communications device that is equipped with a DB-9 male connector. The cable is terminated with two DB-9 female connectors, one of which fits the analyzer's COM1 port.

Some older computers or code activated switches with a DB-25 serial connector will need a different cable or an appropriate adapter.

5.5.2. RS-232 MULTIDROP (OPTION 62)

The multidrop option is used with any of the RS-232 serial ports to enable communications of up to eight analyzers with the host computer over a chain of RS-232 cables via the instruments COM1 Port. It is subject to the distance limitations of the RS 232 standard.

The option consists of a small printed circuit assembly, which is plugs into to the analyzer's CPU card (see Figure 5-4) and is connected to the RS-232 and COM2 DB9 connectors on the instrument's back panel via a cable to the motherboard. One option 62 is required for each analyzer along with one 6' straight-through, DB9 male → DB9 Female cable (P/N WR0000101).

This option can be installed in conjunction with the Ethernet option (Option 63) allowing the instrument to communicate on both types of networks simultaneously. For more information on using and setting up this option see Section 6.10.7)

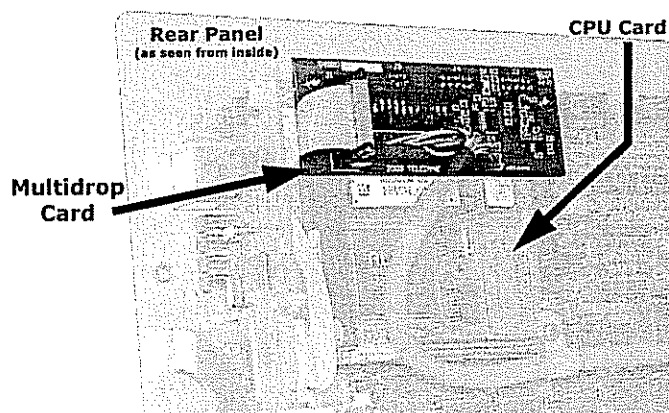

Figure 5-4: 6400E Multidrop Card

5.5.3. ETHERNET (OPTION 63)

The Ethernet option allows the analyzer to be connected to any Ethernet local area network (LAN) running TCP/IP. The local area network must have routers capable of operating at 10BaseT. If Internet access is available through the LAN, this option also allows communication with the instrument over the public Internet.

When installed, this option is electronically connected to the instrument's COM2 serial port making that port no longer available for RS-232/RS-485 communications through the COM2 connector on the rear panel. The option consists of a Teledyne Instruments designed Ethernet card (see Figure 5-5), which is mechanically attached to the instrument's rear panel (see Figure 5-6). A 7-foot long CAT-5 network cable, terminated at both ends with standard RJ-45 connectors, is included as well. Maximum communication speed is limited by the RS-232 port to 115.2 kBaud.

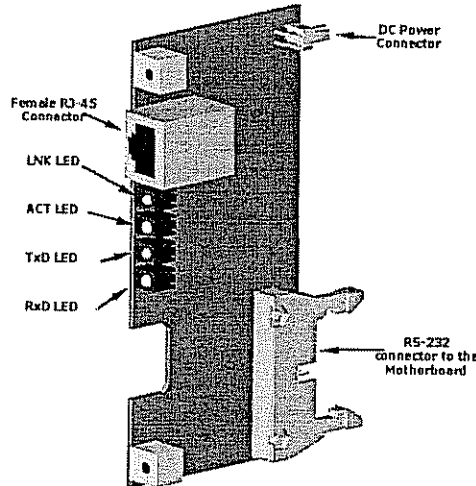

Figure 5-5: 6400E Ethernet Card

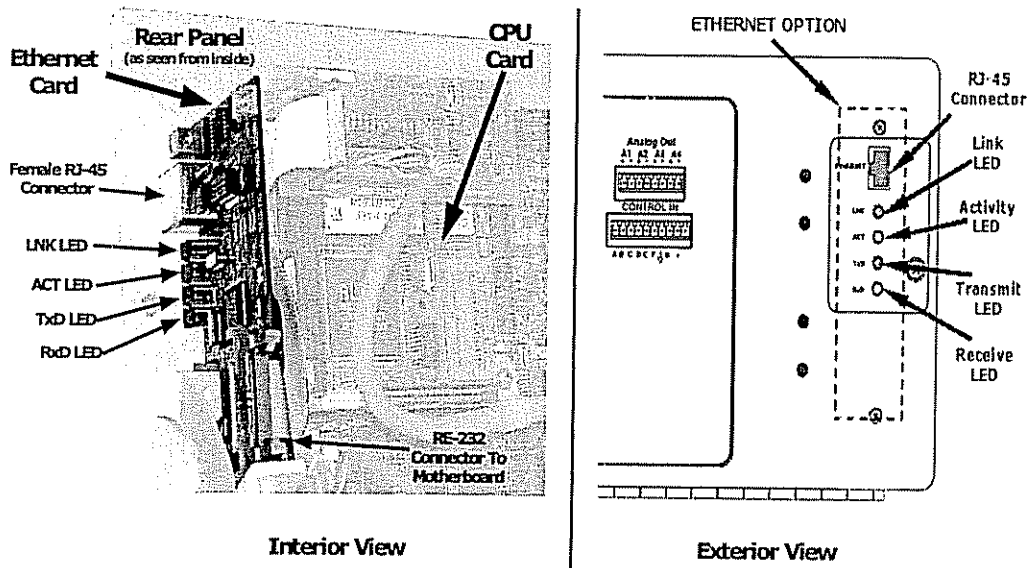

Figure 5-6: 6400E Rear Panel with Ethernet Installed

This option can be installed in conjunction with the RS-2323 multidrop (option 62) allowing the instrument to communicate on both types of networks simultaneously. For more information on using and setting up this option see Section 6.10.6)

5.6. ADDITIONAL MANUALS

5.6.1. PRINTED MANUALS (OPTION 70)

Additional printed copies of this manual are available from Teledyne Analytical Instruments

5.7. EXTENDED WARRANTY (OPTIONS 92 & 93)

Two options are available for extending Teledyne Instruments' standard warranty (see Section 2.4). Both options have to be specified upon ordering the analyzer.

OPTION NUMBER	DESCRIPTION
OPT 92	Extends warranty to cover a two (2) year period from the date of purchase.
OPT 93	Extends warranty to cover a five (5) year period from the date of purchase.

5.8. SPECIAL SOFTWARE FEATURES

5.8.1. MAINTENANCE MODE SWITCH

Teledyne Analytical Instruments analyzers are equipped with a switch that places the instrument in maintenance mode. When present, the switch is accessed by opening the hinged front panel and is located on the rearward facing side of the display/keyboard driver PCA; on the left side; near the particulate filter.

When in maintenance mode the instrument ignores all commands received via the COMM ports that alter the operation state of the instrument. This includes all calibration commands, diagnostic menu commands and the reset instrument command. The instrument continues to measure concentration and send data when requested.

This feature is of particular use for instruments connected to multidrop or Hessen protocol networks.

5.8.2. SECOND LANGUAGE SWITCH

Teledyne Analytical Instruments analyzers are equipped with a switch that activates an alternate set of display messages in a language other than the instrument's default language. This switch is accessed by opening the hinged front panel and is located on the rearward facing side of the display/keyboard driver PCA; on the right side.

To activate this feature, the instrument must also have a specially programmed Disk on Chip containing the second language. Contact Teledyne Instruments Customer Service personnel for more information.

5.8.3. DILUTION RATIO OPTION

The dilution ration feature is a software option that is designed for applications where the sample gas is diluted before being analyzed by the Model 6400E. Typically this occurs in continuous emission monitoring (CEM) applications where the quality of gas in a smoke stack is being tested and the sampling method used to remove the gas from the stack dilutes the gas.

Once the degree of dilution is known, this feature allows the user to add an appropriate scaling factor to the analyzer's SO_2 concentration calculation so that the measurement range and concentration values displayed on the instrument's front panel display and reported via the analog and serial outputs reflect the undiluted values.

Contact Teledyne Analytical Instruments Customer Service personnel for information on activating this feature.

Instructions for using the dilution ratio option can be found in Section 6.7.8.

User Notes:

6. OPERATING INSTRUCTIONS

To assist in navigating the analyzer’s software, a series of menu trees can be found in Appendix A of this manual.

NOTE

The flow charts appearing in this section contain typical representations of the analyzer’s display during the various operations being described. These representations may differ slightly from the actual display of your instrument.

The ENTR key may disappear if you select a setting that is invalid or out of the allowable range for that parameter, such as trying to set the 24-hour clock to 25:00:00. Once you adjust the setting to an allowable value, the ENTR key will re-appear.

6.1. OVERVIEW OF OPERATING MODES

The 6400E software has a variety of operating modes. Most commonly, the analyzer will be operating in **SAMPLE** mode. In this mode, a continuous read-out of the SO₂ concentration is displayed on the front panel and output as an analog voltage from rear panel terminals, calibrations can be performed, and **TEST** functions and **WARNING** messages can be examined.

The second most important operating mode is **SETUP** mode. This mode is used for performing certain configuration operations, such as for the iDAS system, the reporting ranges, or the serial (RS-232/RS-485/Ethernet) communication channels. The **SET UP** mode is also used for performing various diagnostic tests during troubleshooting.

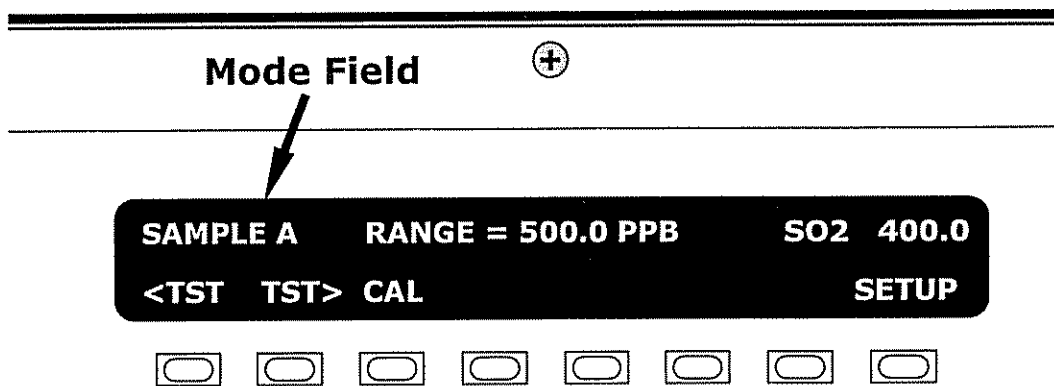

Figure 6-1: Front Panel Display

The mode field of the front panel display indicates to the user which operating mode the unit is currently running.

Besides **SAMPLE** and **SETUP**, other modes the analyzer can be operated in are:

Table 6-1: Analyzer Operating modes

MODE	EXPLANATION
DIAG	One of the analyzer's diagnostic modes is active (see Section 6.9).
LO CAL A	Unit is performing LOW SPAN (midpoint) calibration initiated automatically by the analyzer's AUTOCAL feature
LO CAL R	Unit is performing LOW SPAN (midpoint) calibration initiated remotely through the COM ports or digital control inputs.
M-P CAL	This is the basic calibration mode of the instrument and is activated by pressing the CAL key.
SAMPLE	Sampling normally, flashing text indicates adaptive filter is on.
SAMPLE A	Indicates that unit is in SAMPLE mode and AUTOCAL feature is activated.
SETUP X.#²	SETUP mode is being used to configure the analyzer. The gas measurement will continue during this process.
SPAN CAL A¹	Unit is performing SPAN calibration initiated automatically by the analyzer's AUTOCAL feature
SPAN CAL M¹	Unit is performing SPAN calibration initiated manually by the user.
SPAN CAL R¹	Unit is performing SPAN calibration initiated remotely through the COM ports or digital control inputs.
ZERO CAL A¹	Unit is performing ZERO calibration procedure initiated automatically by the AUTOCAL feature
ZERO CAL M¹	Unit is performing ZERO calibration procedure initiated manually by the user.
ZERO CAL R¹	Unit is performing ZERO calibration procedure initiated remotely through the COM ports or digital control inputs.
¹ Only Appears on units with Z/S valve or IZS options	
² The revision of the analyzer firmware is displayed following the word SETUP, e.g., SETUP C.4	

Finally, the various **CAL** modes allow calibration of the analyzer. Because of its importance, this mode is described separately in Chapter 7.

6.2. SAMPLE MODE

This is the analyzer's standard operating mode. In this mode, the instrument is analyzing SO₂ and calculating concentrations.

6.2.1. TEST FUNCTIONS

A series of test functions is available at the front panel while the analyzer is in **SAMPLE** mode. These parameters provide information about the present operating status of the instrument and are useful during troubleshooting (see Section 11.1.2). They can also be recorded in one of the iDAS channels (see Section 6.11) for data analysis. To view the test functions, press one of the <TST TST> keys repeatedly in either direction.

Table 6-2: Test Functions Defined

DISPLAY	PARAMETER	UNITS	DESCRIPTION
RANGE	RANGE -- RANGE1 RANGE2	PPB, PPM, UGM & MGM	The Full Scale limit at which the reporting range of the analyzer's ANALOG OUTPUTS are currently set. THIS IS NOT the Physical Range of the instrument. See Section 6.7 for more information. If DUAL or AUTO Range modes have been selected, two RANGE functions will appear, one for each range.
STABIL	STABILITY	mV	Standard deviation of SO ₂ Concentration readings. Data points are recorded every ten seconds. The calculation uses the last 25 data points.
PRES	SAMPLE PRESSURE	in-Hg-A	The current pressure of the sample gas as it enters the sample chamber, measured between the SO ₂ and Auto-Zero valves.
SAMP FL	SAMPLE FLOW	cm ³ /min (cc/m)	The flow rate of the sample gas through the sample chamber. This value is not measured but calculated from the sample pressure.
PMT	PMT Signal	mV	The raw output voltage of the PMT.
NORM PMT	NORMALIZED PMT Signal	mV	The output voltage of the PMT after normalization for offset and temperature/pressure compensation (if activated).
UV LAMP	Source UV Lamp Intensity	mV	The output voltage of the UV reference detector.
LAMP RATIO	UV Source lamp ratio	%	The current output of the UV reference detector divided by the reading stored in the CPU's memory from the last time a UV Lamp calibration was performed.
STR. LGT	Stray Light	ppb	The offset due to stray light recorded by the CPU during the last zero-point calibration performed.
DRK PMT	Dark PMT	mV	The PMT output reading recorded the last time the UV source lamp shutter was closed.
DRK LMP	Dark UV Source Lamp	mV	The UV reference detector output reading recorded the last time the UV source lamp shutter was closed.
SLOPE	SO ₂ measurement Slope	-	The sensitivity of the instrument as calculated during the last calibration activity. The slope parameter is used to set the span calibration point of the analyzer.
OFFSET	SO ₂ measurement Offset	-	The overall offset of the instrument as calculated during the last calibration activity. The offset parameter is used to set the zero point of the analyzer response.
HVPS	HVPS	V	The PMT high voltage power supply.
RCELL TEMP	SAMPLE CHAMBER TEMP	°C	The current temperature of the sample chamber.
BOX TEMP	BOX TEMPERATURE	°C	The ambient temperature of the inside of the analyzer case.
PMT TEMP	PMT TEMPERATURE	°C	The current temperature of the PMT.
IZS TEMP¹	IZS TEMPERATURE ¹	°C	The current temperature of the internal zero/span option. Only appears when IZS option is enabled
TEST²	TEST SIGNAL ²	mV	Signal of a user-defined test function on output channel A4.
TIME	CLOCK TIME	hh:mm:ss	The current day time for iDAS records and calibration events.

To view the TEST Functions press the following Key sequence:

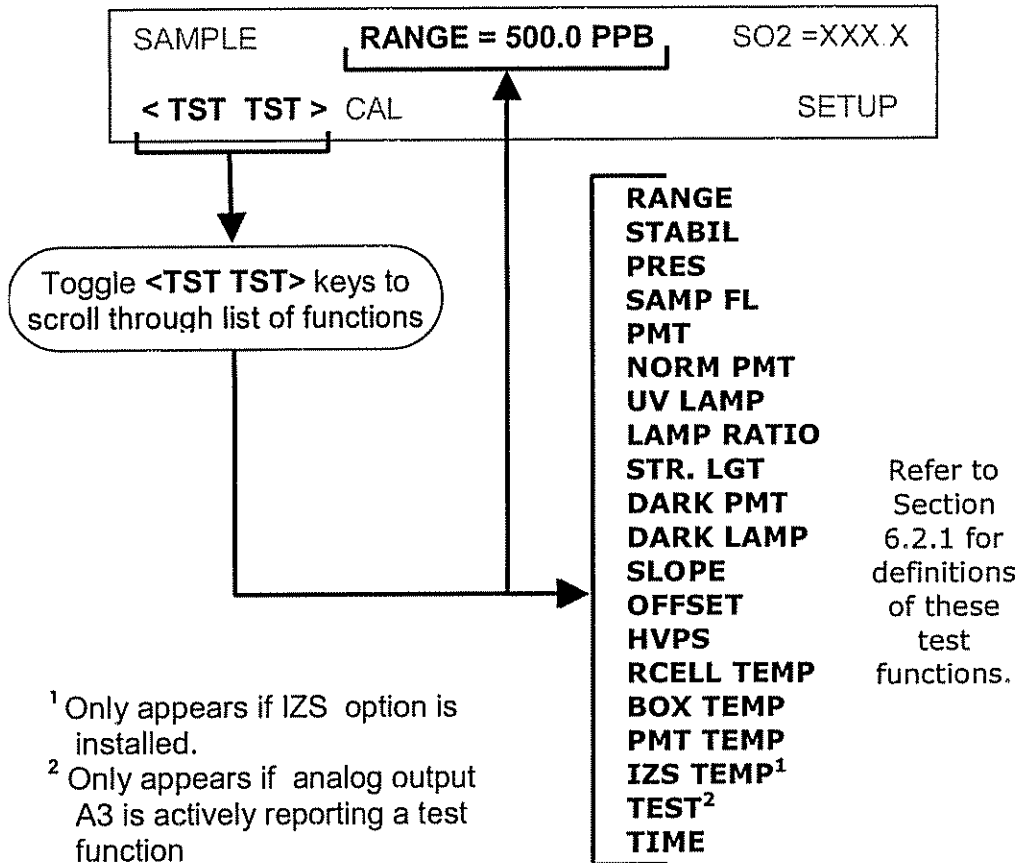

Figure 6-2 Viewing 6400E TEST Functions

NOTE

A value of "XXXX" displayed for any of the TEST functions indicates an out-of-range reading or the analyzer's inability to calculate it.

All pressure measurements are represented in terms of absolute pressure. Absolute, atmospheric pressure is 29.92 in-Hg-A at sea level. It decreases about 1 in-Hg per 300 m gain in altitude. A variety of factors such as air conditioning and passing storms can cause changes in the absolute atmospheric pressure.

6.2.2. WARNING MESSAGES

The most common instrument failures will be reported as a warning on the analyzer’s front panel and through the COM ports. Section 11.1.1 explains how to use these messages to troubleshoot problems. Section 3.2.3 shows how to view and clear warning messages. Table 6-3 lists all warning messages for the current version of software.

Table 6-3: List of Warning Messages

MESSAGE	MEANING
ANALOG CAL WARNING	The instruments A/D circuitry or one of its analog outputs is not calibrated.
BOX TEMP WARNING	The temperature inside the 6400E chassis is outside the specified limits.
CANNOT DYN SPAN	Remote span calibration failed while the dynamic span feature was set to turned on
CANNOT DYN ZERO	Remote zero calibration failed while the dynamic zero feature was set to turned on
CONFIG INITIALIZED	Configuration was reset to factory defaults or was erased.
DARK CAL WARNING	Dark offset above limit specified indicating that too much stray light is present in the sample chamber.
DATA INITIALIZED	iDAS data storage was erased.
FRONT PANEL WARN	Firmware is unable to communicate with the front panel.
HVPS WARNING	High voltage power supply for the PMT is outside of specified limits.
IZS TEMP WARNING	On units with IZS options installed: The permeation tube temperature is outside of specified limits.
PMT DET WARNING	PMT detector output outside of operational limits.
PMT TEMP WARNING	PMT temperature is outside of specified limits.
RCELL TEMP WARNING	Sample chamber temperature is outside of specified limits.
REAR BOARD NOT DET	The CPU is unable to communicate with the motherboard.
RELAY BOARD WARN	The firmware is unable to communicate with the relay board.
SAMPLE FLOW WARN	The flow rate of the sample gas is outside the specified limits.
SAMPLE PRESS WARN	Sample pressure outside of operational parameters.
SYSTEM RESET	The computer was rebooted.
UV LAMP WARNING	The UV lamp intensity measured by the reference detector reading too low or too high

To view and clear warning messages

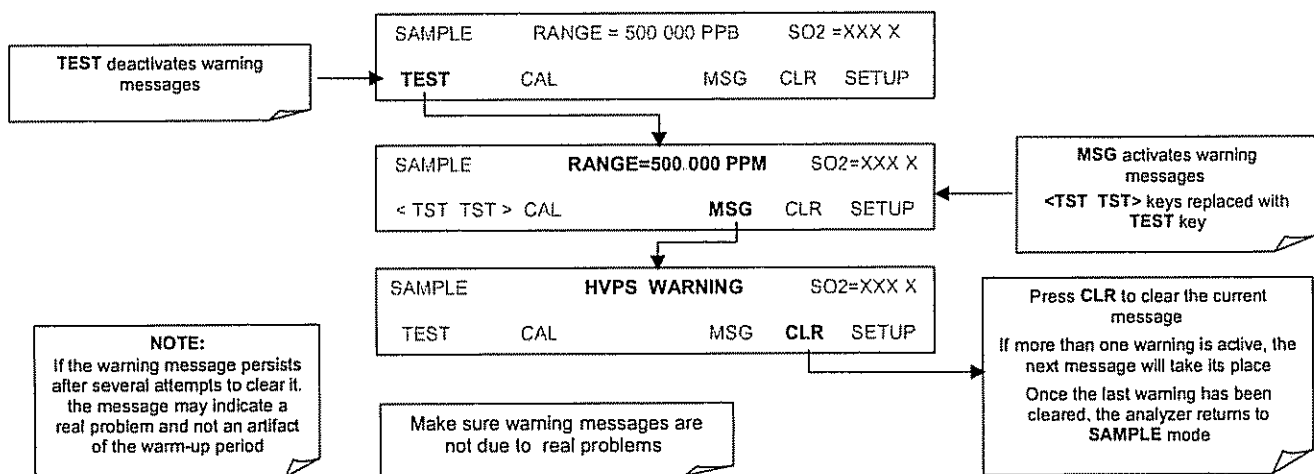

Figure 6-3 Viewing and Clearing 6400E WARNING Messages

6.3. CALIBRATION MODE

6.3.1. CALIBRATION FUNCTIONS

Pressing the **CAL** key switches the 6400E into calibration mode. In this mode, the user can calibrate the instrument with the use of calibrated zero or span gases.

If the instrument includes either the zero/span valve option or IZS option, the display will also include **CALZ** and **CALS** keys. Pressing either of these keys also puts the instrument into multipoint calibration mode.

- The **CALZ** key is used to initiate a calibration of the zero point.
- The **CALS** key is used to calibrate the span point of the analyzer. It is recommended that this span calibration is performed at 90% of full scale of the analyzer's currently selected reporting range.

Because of their critical importance and complexity, calibration operations are described in detail in other sections of the manual:

- Chapter 7 details basic calibration and calibration check operations.
- Chapter 8 describes how to perform an APE protocol calibration.

For more information concerning the zero/span, zero/span/shutoff and IZS valve options, see Section 5.4.

6.3.2. SETUP – PASS: CALIBRATION PASSWORD SECURITY

The 6400E calibration functions may be password protected for to prevent inadvertent adjustments. When the calibration password has been enabled using the **PASS** menu item found under the Setup Menu (see below), the system will prompt the user for a password anytime **CAL**, **CALZ**, **CALS** activated.

The default status of the calibration password is **OFF**. To enable the calibration password press:

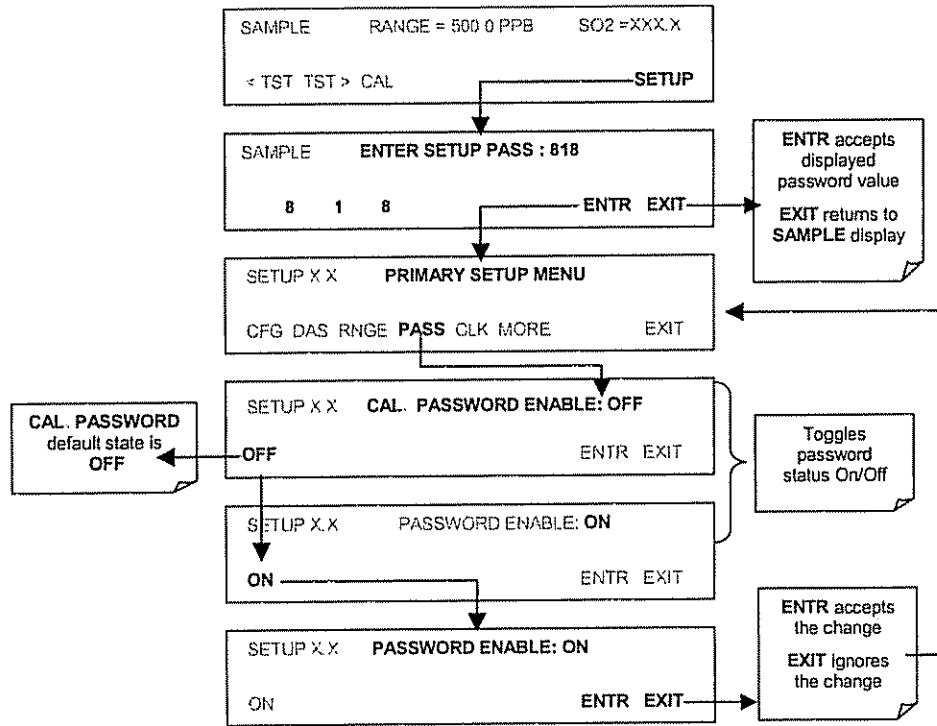

If the calibration password (**100**) is enabled, the following keypad sequence will be required to enter one of the calibration modes:

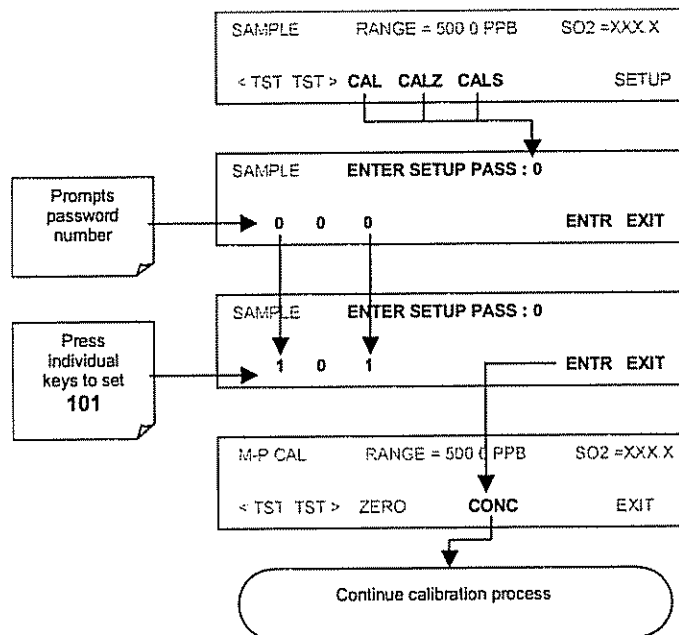

6.4. SETUP MODE

The **SETUP** mode contains a variety of choices that are used to configure the analyzer's hardware and software features, perform diagnostic procedures, gather information on the instruments performance and configure or access data from the internal data acquisition system (iDAS). For a visual representation of the software menu trees, refer to Appendix A-1.

The areas access under the Setup mode are:

Table 6-4: Primary Setup Mode Features and Functions

MODE OR FEATURE	KEYPAD LABEL	DESCRIPTION	MANUAL SECTION
Analyzer Configuration	CFG	Lists key hardware and software configuration information	6.5
Auto Cal Feature	ACAL	Used to set up an operate the AutoCal feature. Only appears if the analyzer has one of the internal valve options installed	7.8
Internal Data Acquisition (iDAS)	DAS	Used to set up the iDAS system and view recorded data	6.11
Analog Output Reporting Range Configuration	RNGE	Used to configure the output signals generated by the instruments Analog outputs.	6.7
Calibration Password Security	PASS	Turns the calibration password feature ON/OFF	6.3.2
Internal Clock Configuration	CLK	Used to Set or adjust the instrument's internal clock	6.6
Advanced SETUP features	MORE	This button accesses the instruments secondary setup menu	See Table 6-5

Table 6-5: Secondary Setup Mode Features and Functions

MODE OR FEATURE	KEYPAD LABEL	DESCRIPTION	MANUAL SECTION
External Communication Channel Configuration	COMM	Used to set up and operate the analyzer's various external I/O channels including RS-232; RS 485, modem communication and/or Ethernet access.	6.10 & 6.12
System Status Variables	VARs	Used to view various variables related to the instruments current operational status	6.8
System Diagnostic Features	DIAG	Used to access a variety of functions that are used to configure, test or diagnose problems with a variety of the analyzer's basic systems	6.9

NOTE

Any changes made to a variable during one of the following procedures is not acknowledged by the instrument until the ENTR Key is pressed

If the EXIT key is pressed before the ENTR key, the analyzer will beep, alerting the user that the newly entered value has not been accepted.

6.4.1. Setup MODE PASSWORD SECURITY

Whenever the Model 6400E's **SETUP** mode is activated the instrument will prompt the user to enter a security password. The default password is **818**. This allows access to all of the instruments basic functions and operating modes as well as some of its more powerful diagnostic tools and variables.

The analyzer will automatically insert **818** into the password prompt field. Simply press **ENTR** to proceed.

Other password levels exist allowing access to special diagnostic tools and variables used only for specific and rarely needed troubleshooting and adjustment procedures. They may be made available as needed by Teledyne Instruments' Customer Service department.

6.5. SETUP – CFG: VIEWING THE ANALYZER'S CONFIGURATION INFORMATION

Pressing the CFG key displays the instrument configuration information. This display lists the analyzer model, serial number, firmware revision, software library revision, CPU type and other information. Use this information to identify the software and hardware when contacting customer service. Special instrument or software features or installed options may also be listed here.

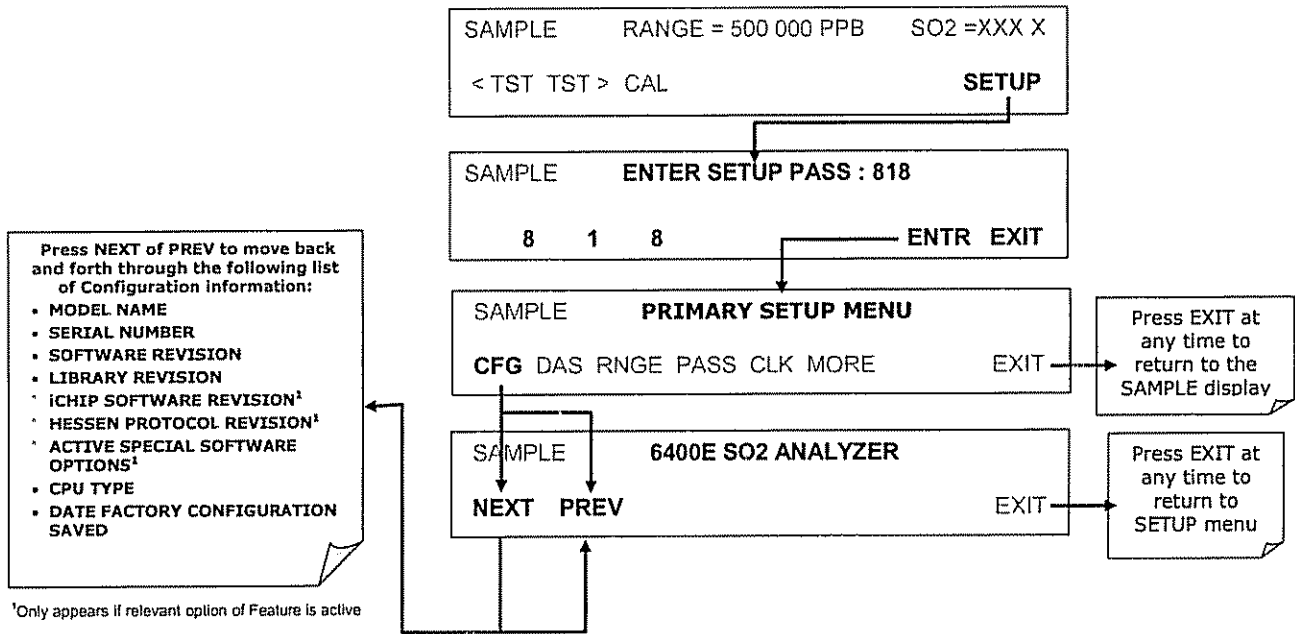

6.6. SETUP – CLK: SETTING THE INTERNAL TIME-OF-DAY CLOCK

The 6400E has a built-in clock for the AutoCal timer, Time **TEST** function, and time stamps on COM port messages and iDAS data entries. To set the time-of-day, press:

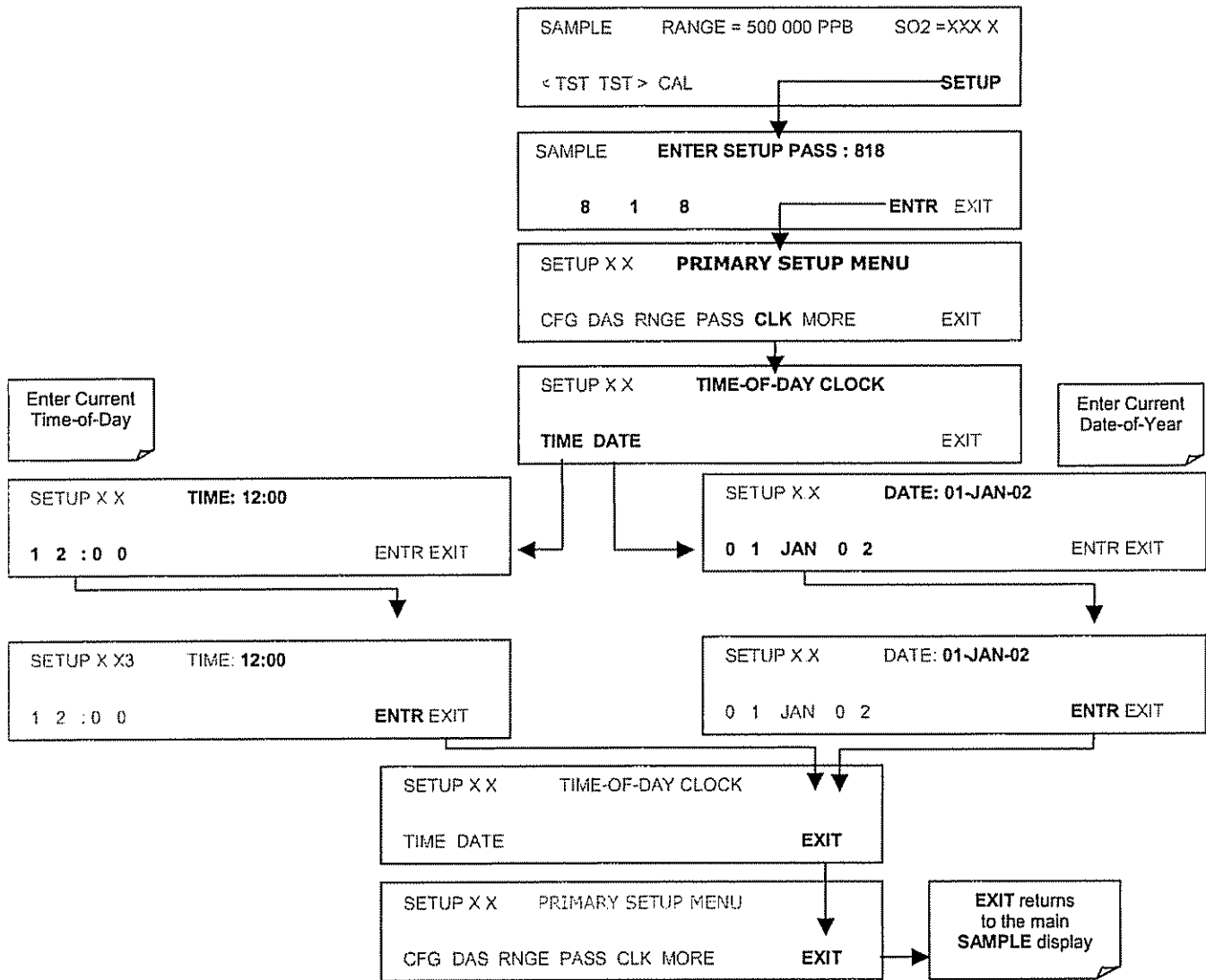

In order to compensate for CPU clocks which run fast or slow, there is a variable to speed up or slow down the clock by a fixed amount every day. To change this variable, press:

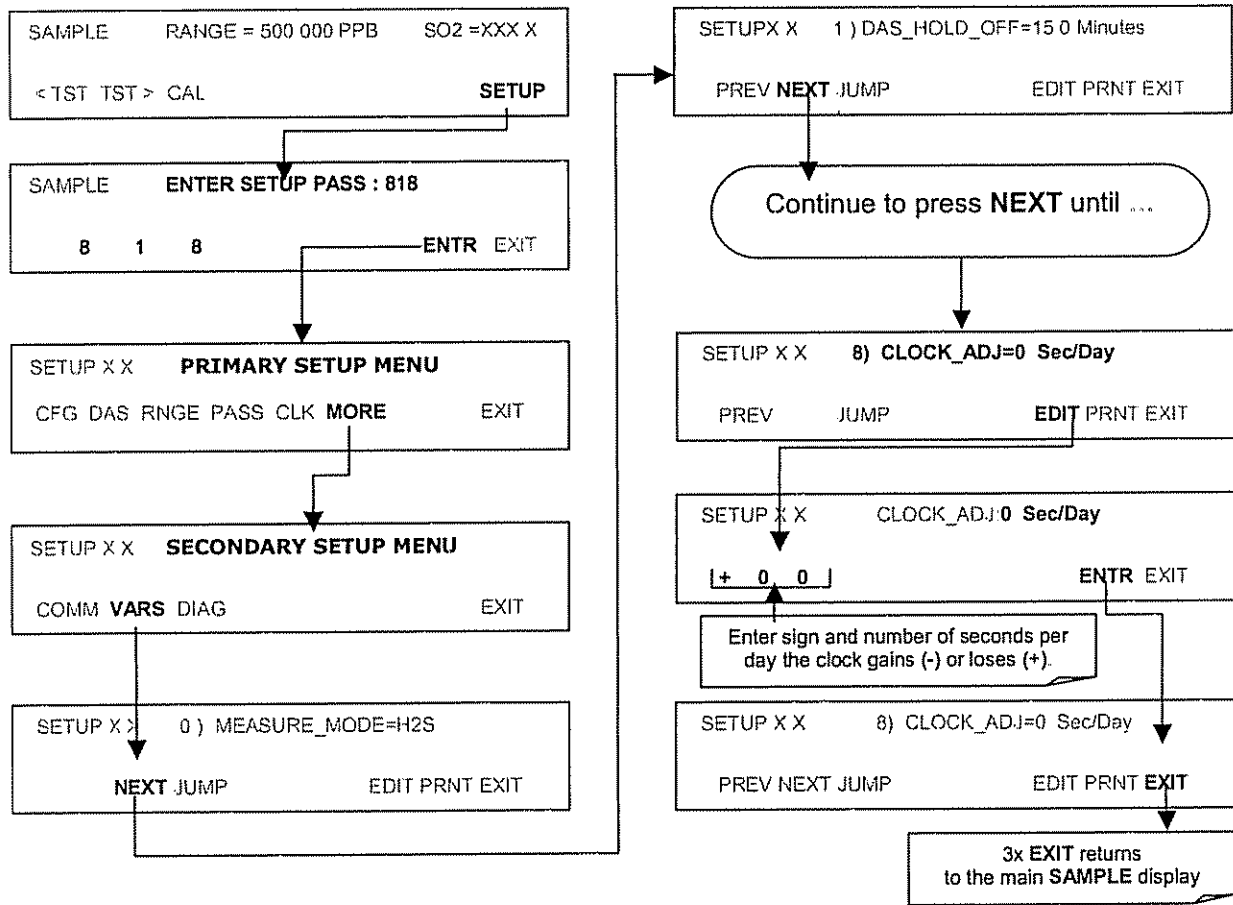

6.7. SETUP – RNGE: ANALOG OUTPUT REPORTING RANGE CONFIGURATION

6.7.1. AVAILABLE ANALOG OUTPUT SIGNALS

The analyzer has three active analog output signals, accessible through a connector on the rear panel.

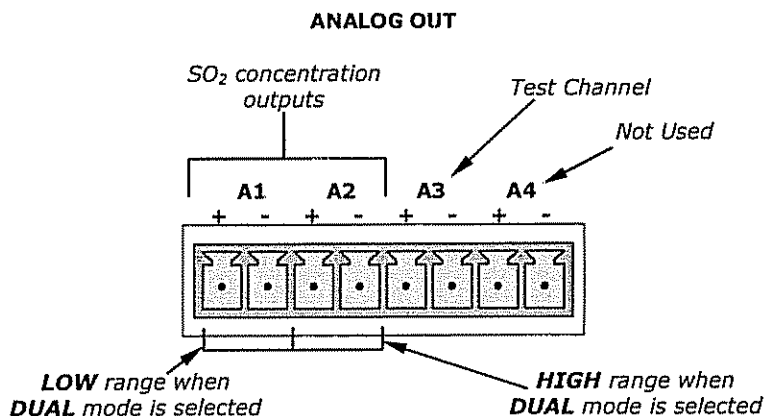

Figure 6-4: Analog Output Connector Key

All three outputs can be configured either at the factory or by the user for full scale outputs of 0.1 VDC, 1VDC, 5VDC or 10VDC. Additionally **A1** and **A2** may be equipped with optional 0-20 mA DC current loop drivers and configured for any current output within that range (e.g. 0-20, 2-20, 4-20, etc.). The user may also adjust the signal level and scaling of the actual output voltage or current to match the input requirements of the recorder or datalogger (See Section 6.9.4.3 & 6.9.4.5).

In its basic configuration, the **A1** and **A2** channels of the 6400E output a signal that is proportional to the SO₂ concentration of the sample gas. Several operating modes are available which allow:

- Single range mode (**SNGL** Mode, see Section 6.7.4): Both outputs are slaved together and will represent the same concentration span (e.g. 0-50 ppm), however their electronic signal levels may be configured for different ranges (e.g. 0-10 VDC vs. 0-.1 VDC – See Section 6.9.4).
- Dual range mode (**DUAL** mode, see Section 6.7.5): The two outputs can be configured for separate and independent units of measure and measurement spans as well as separate electronic signal levels.
- Auto range mode (**AUTO** mode, see Section 6.7.6) gives the analyzer the ability to automatically switch the A1 and A2 analog outputs between two ranges (low and high) dynamically as the concentration value fluctuates.

EXAMPLE:

A1 OUTPUT: Output Signal = 0-5 VDC representing 0-1000 ppm concentration values

A2 OUTPUT: Output Signal = 0 – 10 VDC representing 0-500 ppm concentration values.

The output, labeled **A3** is special. It can be set by the user (see Section 6.9.10) to output any one of the parameters accessible through the **<TST TST>** keys of the units Sample Display.

Output **A4** is not available on the Model 6400E Analyzer.

6.7.2. PHYSICAL RANGE VERSUS ANALOG OUTPUT REPORTING RANGES

The entire measurement range of the 6400E is 0 – 20,000 ppb, but many applications use only a small part of the analyzer's full measurement range. This creates two performance challenges

- The width of the Model 6400E's physical range can create data resolution problems for most analog recording devices. For example, in an application where the expected concentration of SO₂ is typically less than 500 ppb, the full scale of expected values is only 0.25% of the instrument's full 20 000 ppb measurement range. Unmodified, the corresponding output signal would also be recorded across only 0.25% of the range of the recording device.

The 6400E solves this problem by allowing the user to select a scaled reporting range for the analog outputs that only includes that portion of the physical range relevant to the specific application. Only the reporting range of the analog outputs is scaled, the physical range of the analyzer and the readings displayed on the front panel remain unaltered.

- Applications where low concentrations of SO₂ are measured require greater sensitivity and resolution than typically necessary for measurements of higher concentrations.

The 6400E solves this issue by using two hardware physical ranges that cover the instruments entire 0 and 20,000 ppb measurement range: a 0 to 2,000 ppb physical range for increased sensitivity and resolution when measuring very low SO₂ concentrations, and a 0 to 20,000 ppb physical range for measuring higher SO₂ concentrations.

The analyzer's software automatically selects which physical range is in effect based on the analog output reporting range selected by the user.

- If the high end of the selected reporting range is $\leq 2,000$ ppb. The low physical range is selected.
- If the high end of the selected reporting range is $\geq 2,001$ ppb. The high physical range is selected.

Once properly calibrated, the analyzer's front panel will accurately report concentrations along the entire span of its 0 and 20,000 ppb physical range regardless of which reporting range has been selected for the analog outputs and which physical range is being used by the instruments software.

6.7.3. REPORTING RANGE MODES

The 6400E provides three analog output range modes to choose from.

- Single range (**SNGL**) mode sets a single maximum range for the analog output. If single range is selected (see Section 6.7.4) both outputs are slaved together and will represent the same measurement span (e.g. 0-50 ppm), however their electronic signal levels may be configured for different ranges (e.g. 0-10 VDC vs. 0-.1 VDC – See Section 6.9.4.1).
- Dual range (**DUAL**) allows the A1 and A2 outputs to be configured with different measurement spans (see Section 6.7.5).
- Auto range (**AUTO**) mode gives the analyzer the ability to output data via a low range and high range. When this mode is selected (see Section 6.7.6) the 6400E will automatically switch between the two ranges dynamically as the concentration value fluctuates.

Also, in this mode the RANGE Test function displayed on the front panel during SAMPLE mode will be replaced by two separate functions, range1 & range2.

Range status is also output via the External Digital I/O Status Bits (see Section 6.12.1.1).

To select the Analog Output Range Type press:

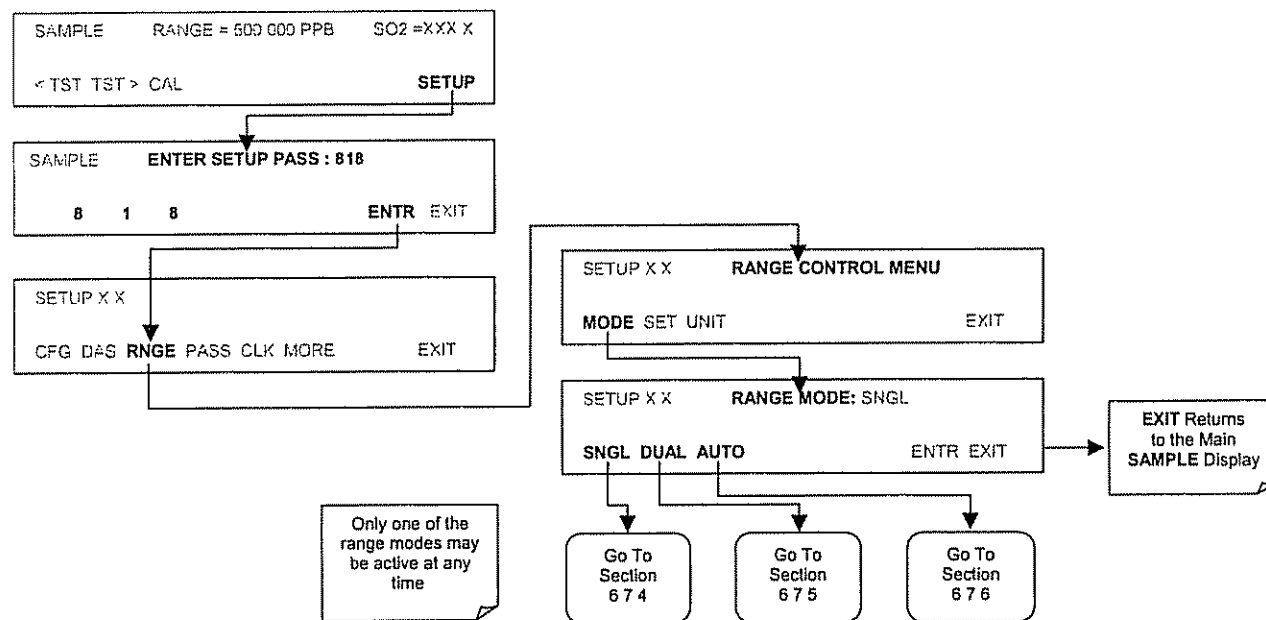

6.7.4. SINGLE RANGE MODE (SNGL)

The default range mode for the analyzer is single range, in which all analog concentration outputs are set to the same reporting range. This reporting range can be set to any value between 0.1 ppb and 20 000 ppb.

While the two outputs always have the same reporting range, the span and scaling of their electronic signals may also be configured for different differently (e.g., **A1** = 0-10 V; **A2** = 0-0.1 V).

To select **SNGL** range mode and to set the upper limit of the range, press:

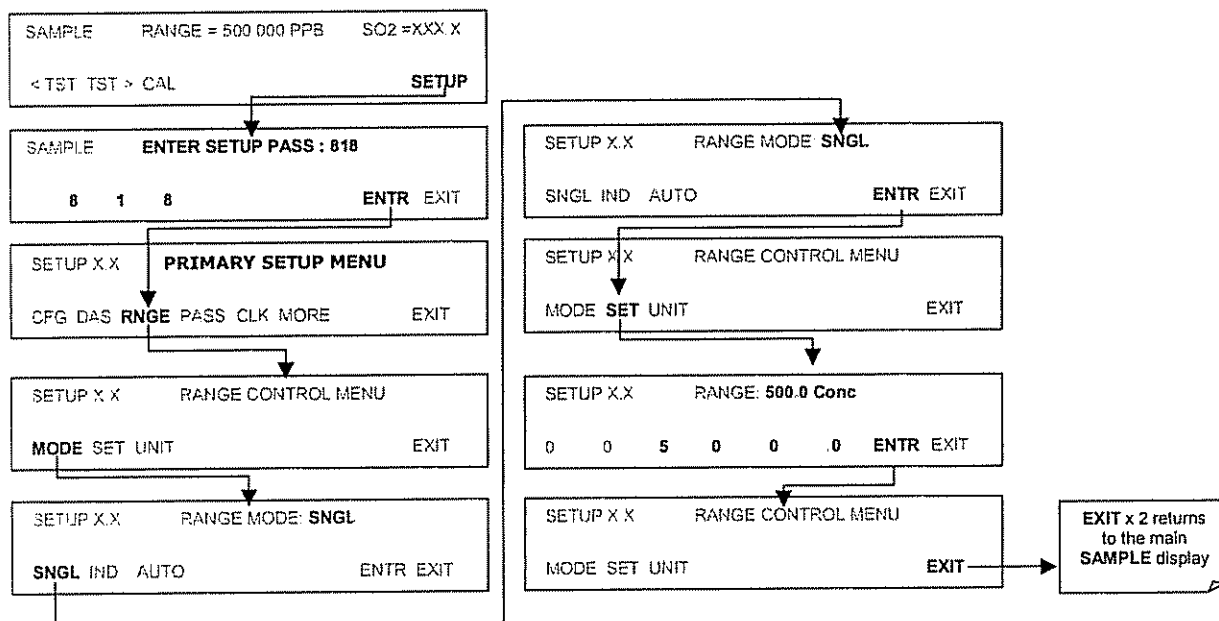

6.7.5. DUAL RANGE MODE (DUAL)

Selecting Dual Range mode allows the **A1** and **A2** outputs to be configured with different reporting ranges. The analyzer software calls these two ranges low and high. The Low range setting corresponds with the analog output labeled **A1** on the rear panel of the instrument. The high range setting corresponds with the **A2** output. While the software names these two ranges low and high, they do not have to be configured that way. For example: the low range can be set for a span of 0-150 ppb while the high range is set for 0-50 ppb.

In **DUAL** range mode the **RANGE** test function displayed on the front panel will be replaced by two separate functions:

RANGE1: The range setting for the **A1** output.

RANGE2: The range setting for the **A2** output.

To set the ranges press following keystroke sequence

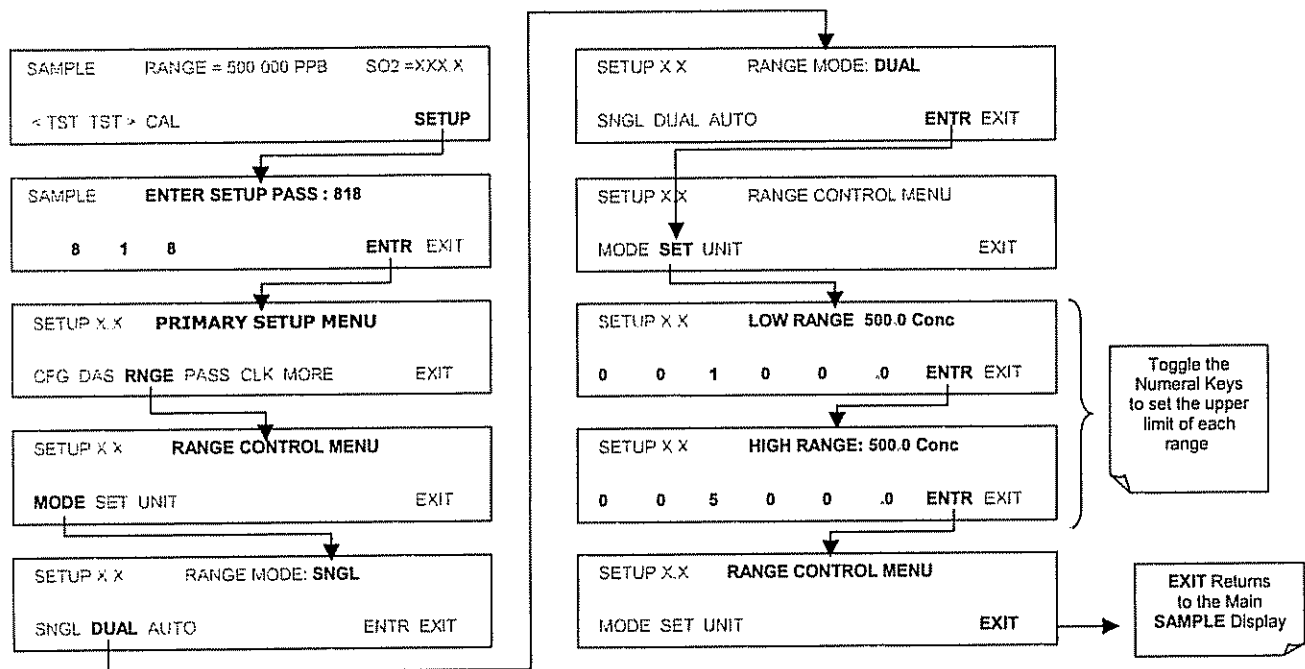

6.7.6. AUTO RANGE MODE (AUTO)

In AUTO range mode, the analyzer automatically switches the reporting range between two user-defined ranges (low and high). The unit will switch from low range to high range when either the SO₂ concentration exceeds 98% of the low range span. The unit will return from high range back to low range once both the SO₂ concentration falls below 75% of the low range span.

In **AUTO** Range mode the instrument reports the same data in the same range on both the **A1** and **A2** outputs and automatically switches both outputs between ranges as described above. Also, the **RANGE** test function displayed on the front panel will be replaced by two separate functions:

RANGE1: The **LOW** range setting for all analog outputs.

RANGE2: The **HIGH** range setting for all analog outputs.

The high/low range status is also reported through the external, digital status bits (see Section 6.12.1.1).

To set individual ranges press the following keystroke sequence.

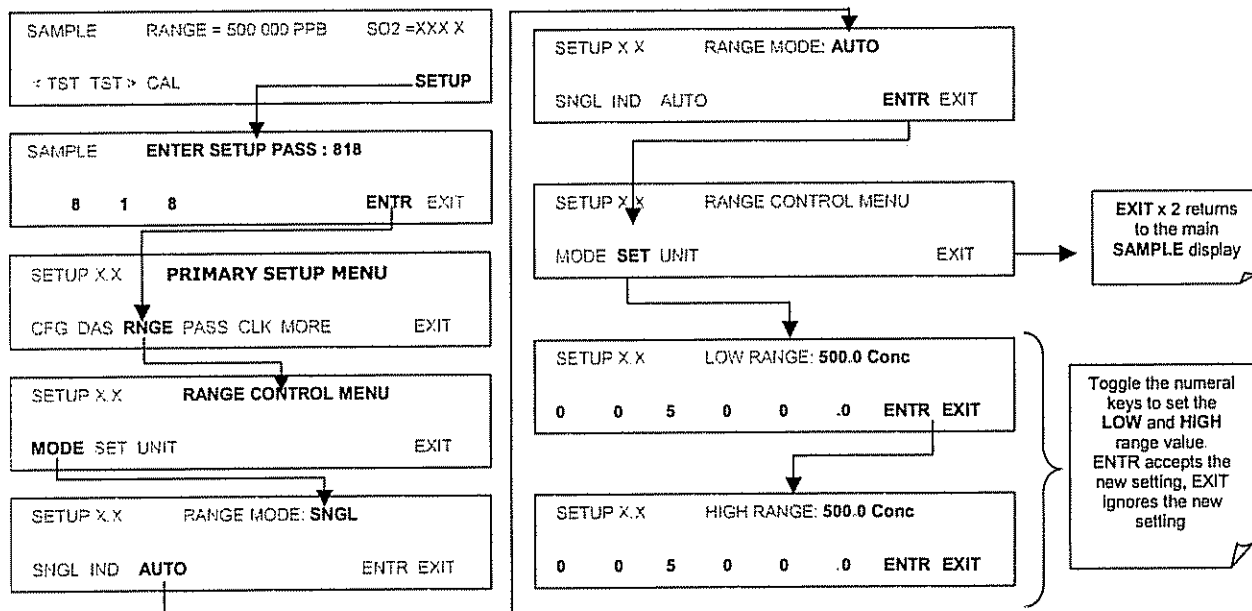

NOTE

In **AUTO** range mode, the **LOW** and **HIGH** ranges have separate slopes and offsets for computing SO₂ concentration.

The two ranges must be independently calibrated.

6.7.7. RANGE UNITS

The 6400E can display concentrations in parts per billion (10^9 mols per mol, PPB), parts per million (10^6 mols per mol, PPM), micrograms per cubic meter ($\mu\text{g}/\text{m}^3$, UG) or milligrams per cubic meter (mg/m^3 , MG). Changing units affects all of the display, analog outputs, COM port and iDAS values for all reporting ranges regardless of the analyzer's range mode.

To change the concentration units:

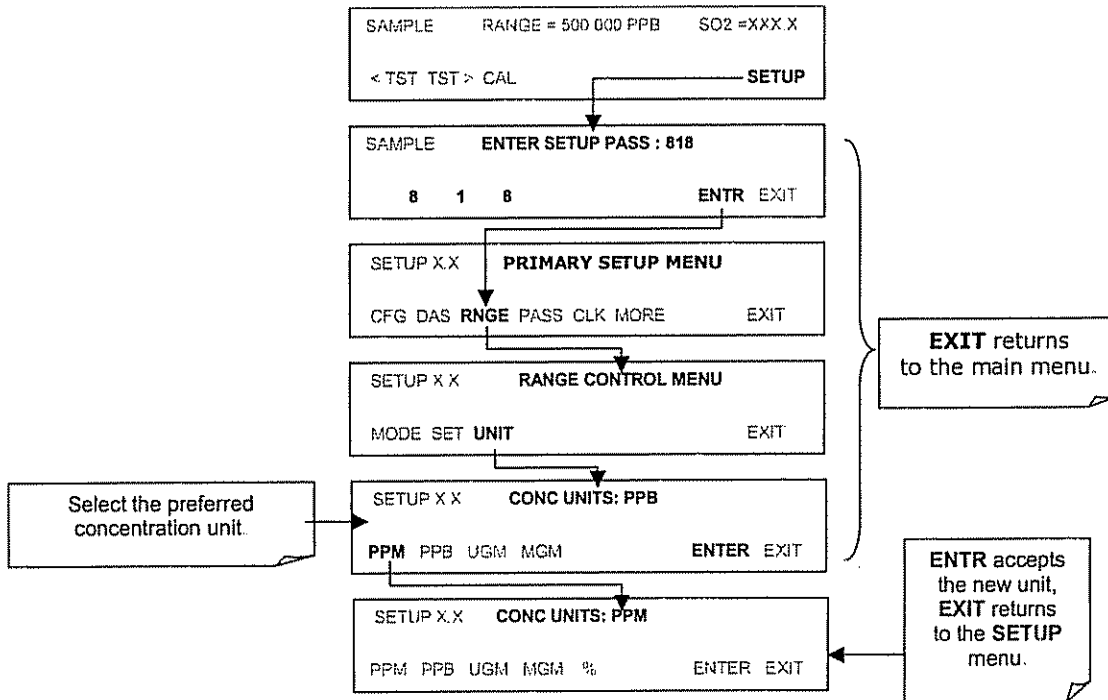

NOTE

Concentrations displayed in mg/m^3 and $\mu\text{g}/\text{m}^3$ use 0°C and 760 Torr as standard temperature and pressure (STP). Consult your local regulations for the STP used by your agency. Here are the conversion factors from volumetric to mass units used in the 6400E:

$$\text{SO}_2 : \text{ppb} \times 1.34 = \mu\text{g}/\text{m}^3; \text{ppm} \times 1.34 = \text{mg}/\text{m}^3$$

6.7.8. DILUTION RATIO

The dilution ratio is a software option that allows the user to compensate for any dilution of the sample gas before it enters the sample inlet. Using the dilution ratio option is a 4-step process:

1. Select reporting range units: Follow the procedure in Section 6.7.7.
2. Select the range: Use the procedures in Section 6.7.4 – 6.7.6. Make sure that the **SPAN** value entered is the maximum expected concentration of the undiluted calibration gas and that the span gas is either supplied through the same dilution inlet system as the sample gas or has an appropriately lower actual concentration. For example, with a dilution set to 100, a 1 ppm gas can be used to calibrate a 100 ppm sample gas if the span gas is not routed through the dilution system. On the other hand, if a 100 ppm span gas is used, it needs to pass through the same dilution steps as the sample gas.
3. Set the dilution factor as a gain (e.g., a value of 20 means 20 parts diluent and 1 part of sample gas):

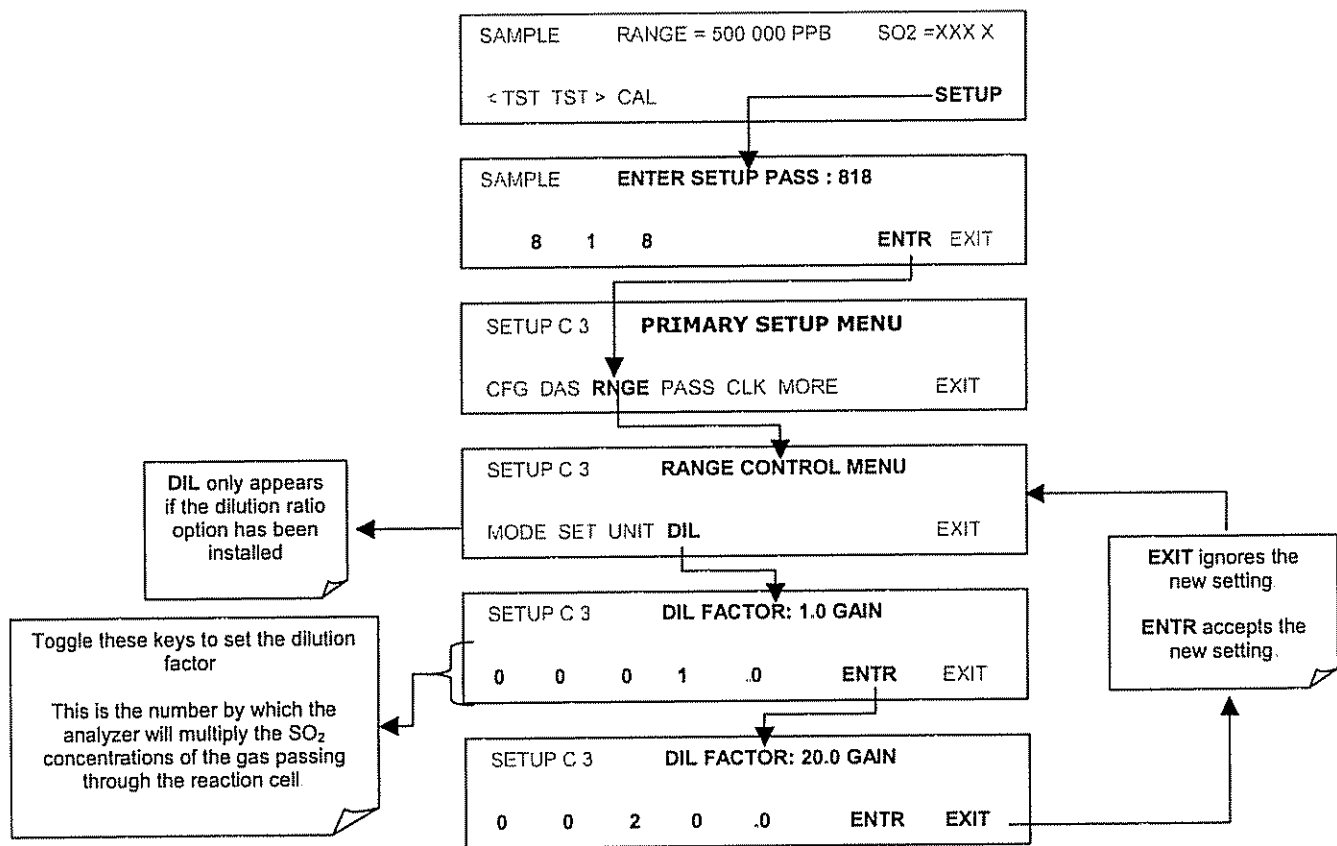

The analyzer multiplies the measured gas concentrations with this dilution factor and displays the result.

NOTE

Once the above settings have been entered, the instrument needs to be recalibrated using one of the methods discussed in Chapter 7.

6.8. SETUP – VARS: USING THE INTERNAL VARIABLES

The 6400E has several-user adjustable software variables, which define certain operational parameters. Usually, these variables are automatically set by the instrument's firmware, but can be manually re-defined using the VARS menu. Table 6-6 lists all variables that are available within the 818 password protected level.

Table 6-6: Variable Names (VARS) Revision C.3

NO.	VARIABLE	DESCRIPTION	ALLOWED VALUES
0	DAS_HOLD_OFF	Changes the internal data acquisition system (iDAS) hold-off time, which is the duration when data are not stored in the iDAS because the software considers the data to be questionable. That is the case during warm-up or just after the instrument returns from one of its calibration modes to SAMPLE mode. DAS_HOLD_OFF can be disabled entirely in each iDAS channel.	Can be between 0.5 and 20 minutes Default=15 min.
1	TPC_ENABLE	Enables or disables the temperature and pressure compensation (TPC) feature (see Section 10.7.3).	ON/OFF
2	RCELL_SET	Sets the sample chamber temperature. Increasing or decreasing this temperature will increase or decrease the rate at which SO ₂ * decays into SO ₂ . (see Section 10.1.1). Do not adjust this setting unless under the direction of TAI customer service personnel.	30° C - 70° C Default= 50° C
3	IZS_SET	Sets the IZS option temperature. Increasing or decreasing this temperature will increase or decrease the permeation rate of the IZS source (see Section 5.4.2).	30° C - 70° C Default= 50° C
4	DYN_ZERO	Dynamic zero automatically adjusts offset and slope of the SO ₂ response when performing a zero point calibration during an AutoCal (see Chapter 7).	ON/OFF
5	DYN_SPAN	Dynamic span automatically adjusts slope and slope of the SO ₂ response when performing a zero point calibration during an AutoCal (see Chapter 7). Note that the DYN_ZERO and DYN_SPAN features are not allowed for applications requiring EPA equivalency.	ON/OFF
6	CONC_PRECISION	Allows the user to set the number of significant digits to the right of the decimal point display of concentration and stability values.	AUTO, 1, 2, 3, 4 Default=AUTO
7	CLOCK_ADJ	Adjusts the speed of the analyzer's clock. Choose the + sign if the clock is too slow, choose the - sign if the clock is too fast.	-60 to +60 s/day

To access and navigate the VARS menu, use the following key sequence.

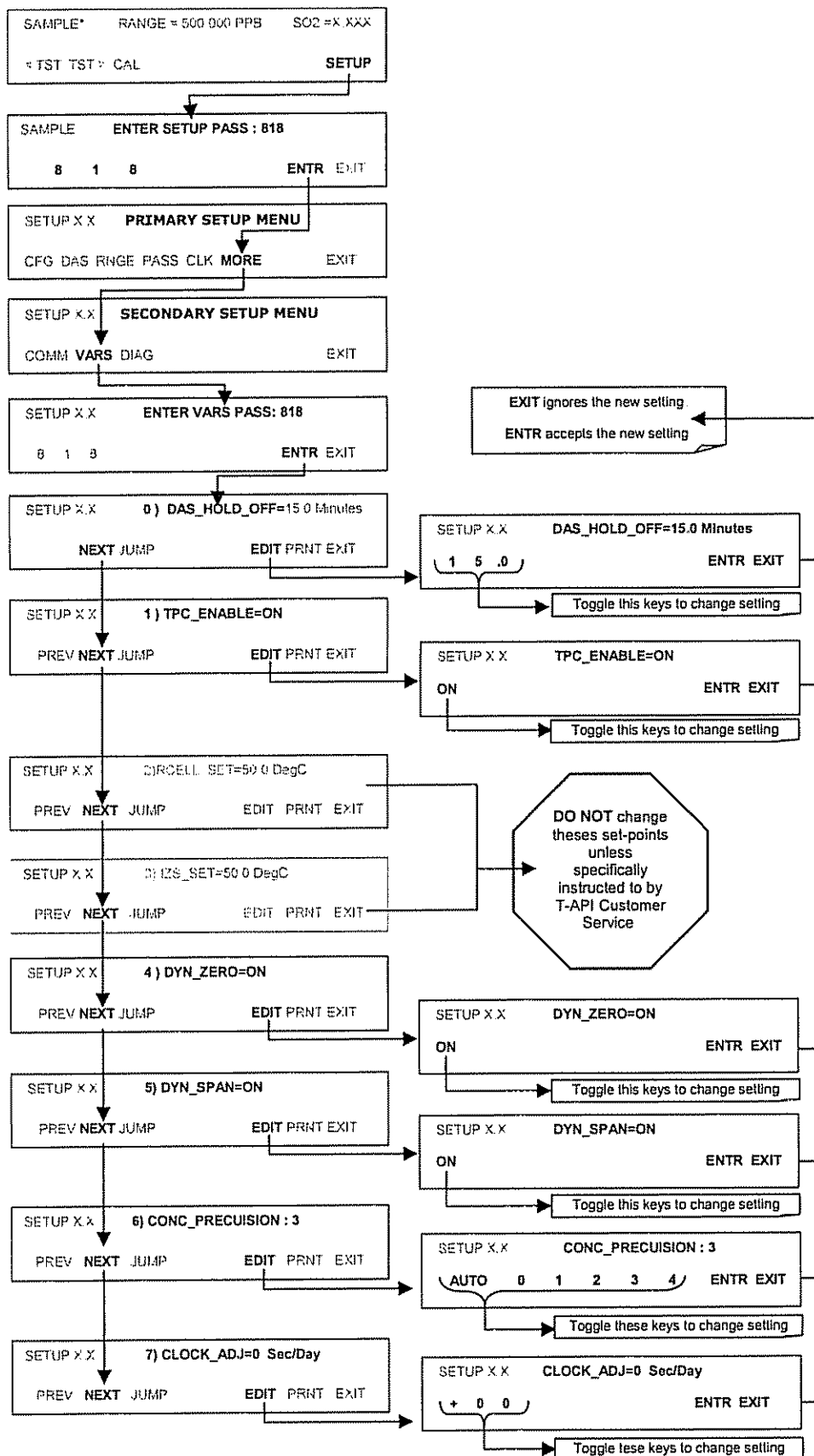

6.9. SETUP – DIAG: USING THE DIAGNOSTICS FUNCTIONS

A series of diagnostic tools is grouped together under the **SETUP→MORE→DIAG** menu. As these parameters are dependent on firmware revision (see Menu Tree A-5 in Appendix A). The individual parameters, however, are explained in more detail in the following section, indicated in Table 6-7. These tools can be used in a variety of troubleshooting and diagnostic procedures and are referred to in many places of the maintenance and trouble-shooting sections.

Table 6-7: 6400E Diagnostic (DIAG) Functions

DIAGNOSTIC FUNCTION AND MEANING	FRONT PANEL MODE INDICATOR	SECTION
SIGNAL I/O: Allows observation of all digital and analog signals in the instrument. Allows certain digital signals such as valves and heaters to be toggled ON and OFF.	DIAG I/O	6.9.2
ANALOG I/O: When entered, the analyzer performs an analog output step test. This can be used to calibrate a chart recorder or to test the analog output accuracy.	DIAG AOUT	6.9.3
ANALOG I/O CONFIGURATION: Analog input/output parameters are available for viewing and configuration.	DIAG AIO	6.9.4
OPTIC TEST: When activated, the analyzer performs an optic test, which turns on an LED located inside the sensor module near the PMT (Fig. 10-15). This diagnostic tests the response of the PMT without having to supply span gas.	DIAG OPTIC	6.9.5
ELECTRICAL TEST: When activated, the analyzer performs an electric test, which generates a current intended to simulate the PMT output to verify the signal handling and conditioning of the PMT preamp board.	DIAG ELEC	6.9.6
LAMP CALIBRATION: The analyzer records the current voltage output of the UV source reference detector. This value is used by the CPU to calculate the lamp ration used in determining the SO ₂ concentration	DIAG LAMP	6.9.7
PRESSURE CALIBRATION: The analyzer records the current output of the sample gas pressure sensor. This value is used by the CPU to compensate the SO ₂ concentration when the TPC feature is enabled.	DIAG PCAL	6.9.8
FLOW CALIBRATION: This function is used to calibrate the gas flow output signals of sample gas and ozone supply. These settings are retained when exiting DIAG.	DIAG FCAL	6.9.9
TEST CHAN OUTPUT: Configures the A4 analog output channel.	DIAG TCHN	6.9.10

6.9.1. ACCESSING THE DIAGNOSTIC FEATURES

To access the **DIAG** functions press the following keys:

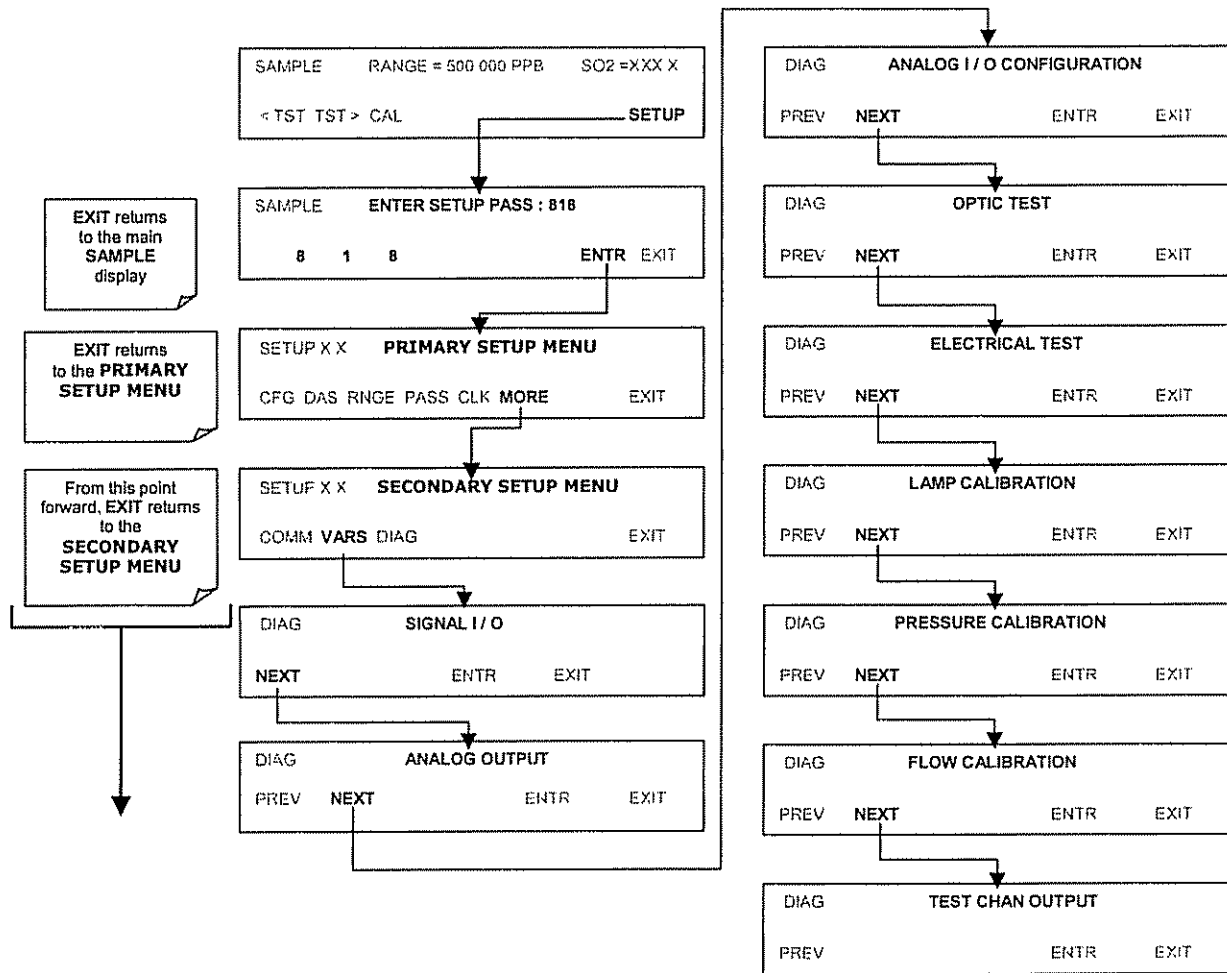

6.9.2. SIGNAL I/O

The signal I/O diagnostic mode allows to review and change the digital and analog input/output functions of the analyzer. See Appendix A-4 for a complete list of the parameters available for review under this menu.

NOTE

Any changes of signal I/O settings will remain in effect only until the signal I/O menu is exited. Exceptions are the ozone generator override and the flow sensor calibration, which remain as entered when exiting.

To enter the signal I/O test mode, press:

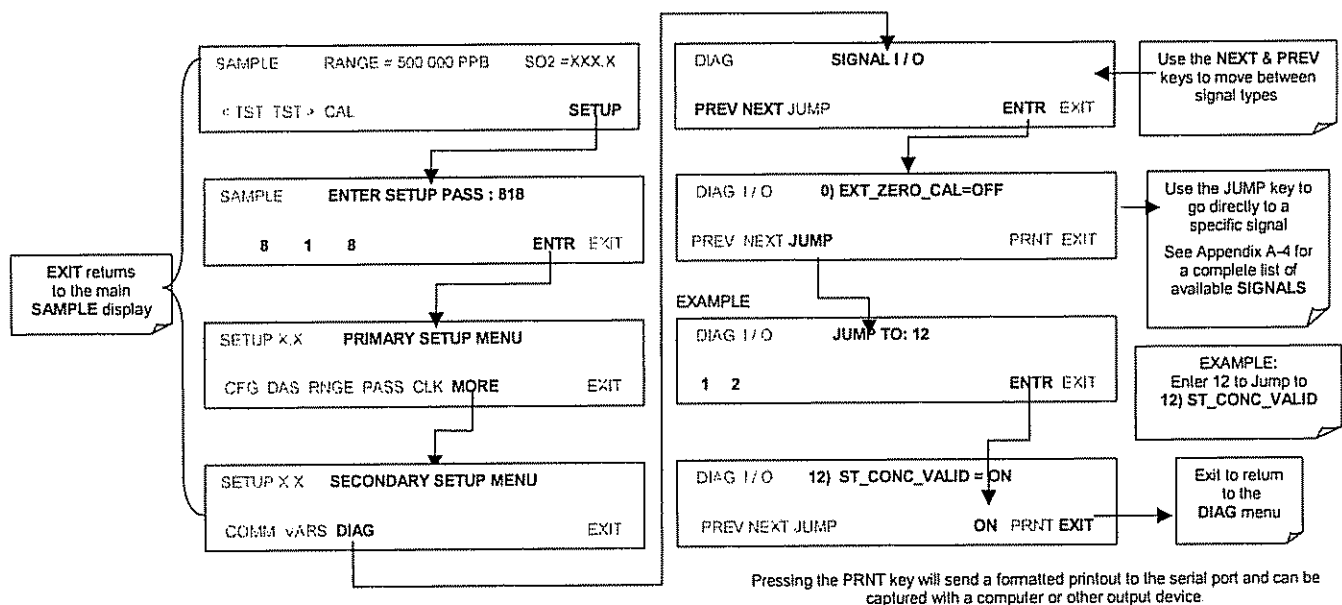

6.9.3. ANALOG OUTPUT STEP TEST

This test can be used to check the accuracy and proper operation of the analog outputs. The test forces all four analog output channels to produce signals ranging from 0% to 100% of the full scale range in 20% increments. This test is useful to verify the operation of the data logging/recording devices attached to the analyzer.

To begin the Analog Output Step Test press:

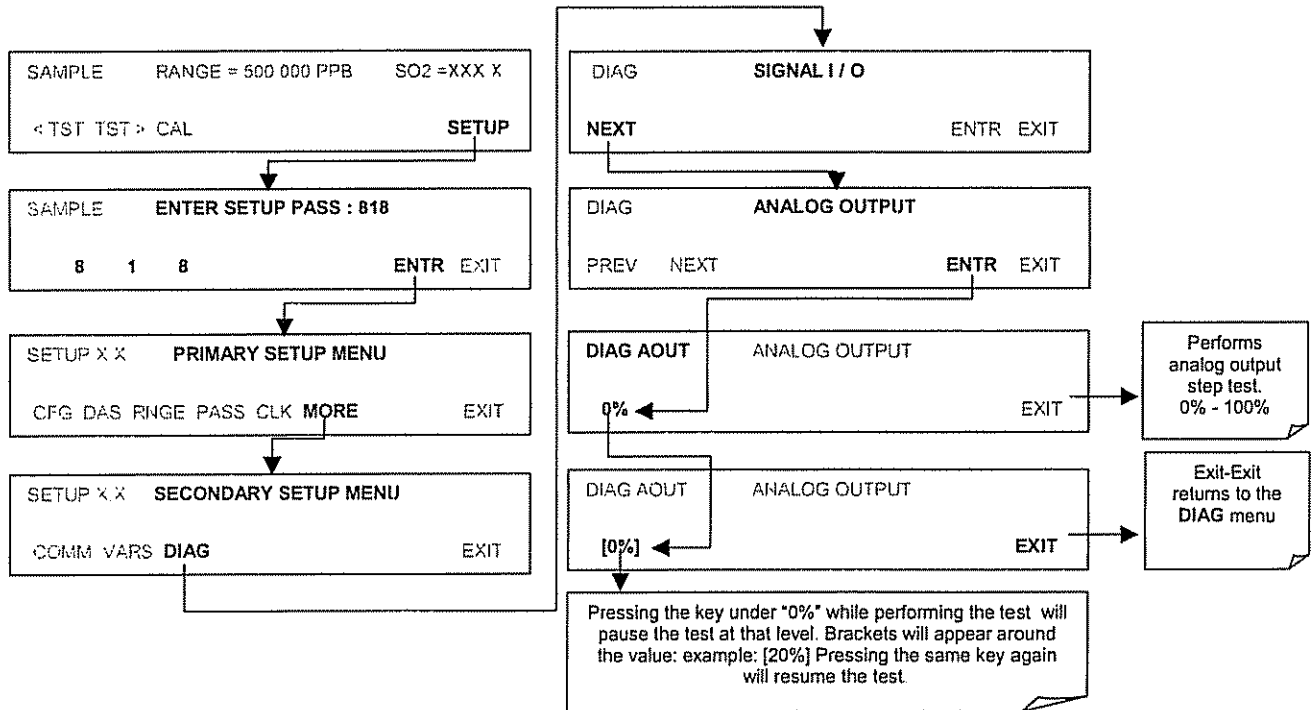

6.9.4. ANALOG I/O CONFIGURATION

Table 6-8 lists the analog I/O functions that are available in the 6400E.

Table 6-8: DIAG - Analog I/O Functions

SUB MENU	FUNCTION
AOUTS CALIBRATED:	Shows the status of the analog output calibration (YES/NO) and initiates a calibration of all analog output channels.
CONC_OUT_1	<p>Sets the basic electronic configuration of the A1 analog output (SO₂) . There are three options:</p> <ul style="list-style-type: none"> • RANGE: Selects the signal type (voltage or current loop) and full scale level of the output. • REC_OFS: Allows to set a voltage offset (not available when RANGE is set to Current loop (CURR)). • AUTO_CAL: Performs the same calibration as AOUT CALIBRATED, but on this one channel only. <p>NOTE: Any change to RANGE or REC_OFS requires recalibration of this output.</p>
CONC_OUT_2	Same as for CONC_OUT_1 but for analog channel 2 (SO ₂)
CONC_OUT_3	Spare
TEST OUTPUT	Same as for CONC_OUT_1 but for analog channel 4 (TEST)
AIN CALIBRATED	Shows the calibration status (YES/NO) and initiates a calibration of the analog to digital converter circuit on the motherboard.

To configure the analyzer’s four analog outputs, set the electronic signal type of each channel and calibrate the outputs. This consists of:

Selecting an output type (voltage or current, if an optional current output driver has been installed) and the signal level that matches the input requirements of the recording device attached to the channel, see Sections 6.9.4.1.

Calibrating the output channel. This can be done automatically or manually for each channel (see Sections 6.9.4.2 & 6.9.4.3).

Adding a bipolar recorder offset to the signal, if required (see Section 6.9.4.4.)

In its standard configuration, the analyzer’s outputs can be set for the following DC voltages. Each range is usable from -5% to + 5% of the nominal range.

Table 6-9: Analog Output Voltage Ranges

RANGE	MINIMUM OUTPUT	MAXIMUM OUTPUT
0-0.1 V	-5 mV	+105 mV
0-1 V	-0.05 V	+1.05 V
0-5 V	-0.25 V	+5.25 V
0-10 V	-0.5 V	+10.5 V
The default offset for all ranges is 0 VDC.		

The following DC current output limits apply to the current loop modules:

Table 6-10: Analog Output Current Loop Range

RANGE	MINIMUM OUTPUT	MAXIMUM OUTPUT
0-20 mA	0 mA	20 mA
These are the physical limits of the current loop modules, typical applications use 2-20 or 4-20 mA for the lower and upper limits. Please specify desired range when ordering this option. The default offset for all ranges is 0 mA.		

Pin assignments for the output connector at the rear panel of the instrument are shown in Table 6-11.

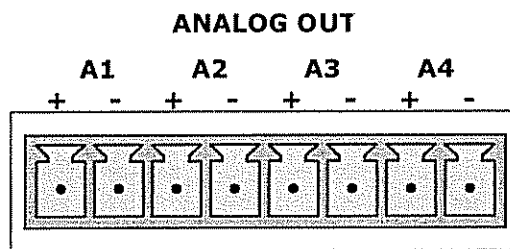

Table 6-11: Analog Output Pin Assignments

PIN	ANALOG OUTPUT	VOLTAGE SIGNAL	CURRENT SIGNAL
1	A1	V Out	I Out +
2		Ground	I Out -
3	A2	V Out	I Out +
4		Ground	I Out -
5	A3	Not Used	Not Used
7	A4	V Out	not available
8		Ground	not available

See Figure 3-1 for a the location of the analog output connector on the instruments rear panel.

6.9.4.1. Analog Output Signal Type and Range Span Selection

To select an output signal type (DC Voltage or current) and level for one output channel, activate the **ANALOG I/O CONFIGURATION MENU** (see Section 6.9.1) then press:

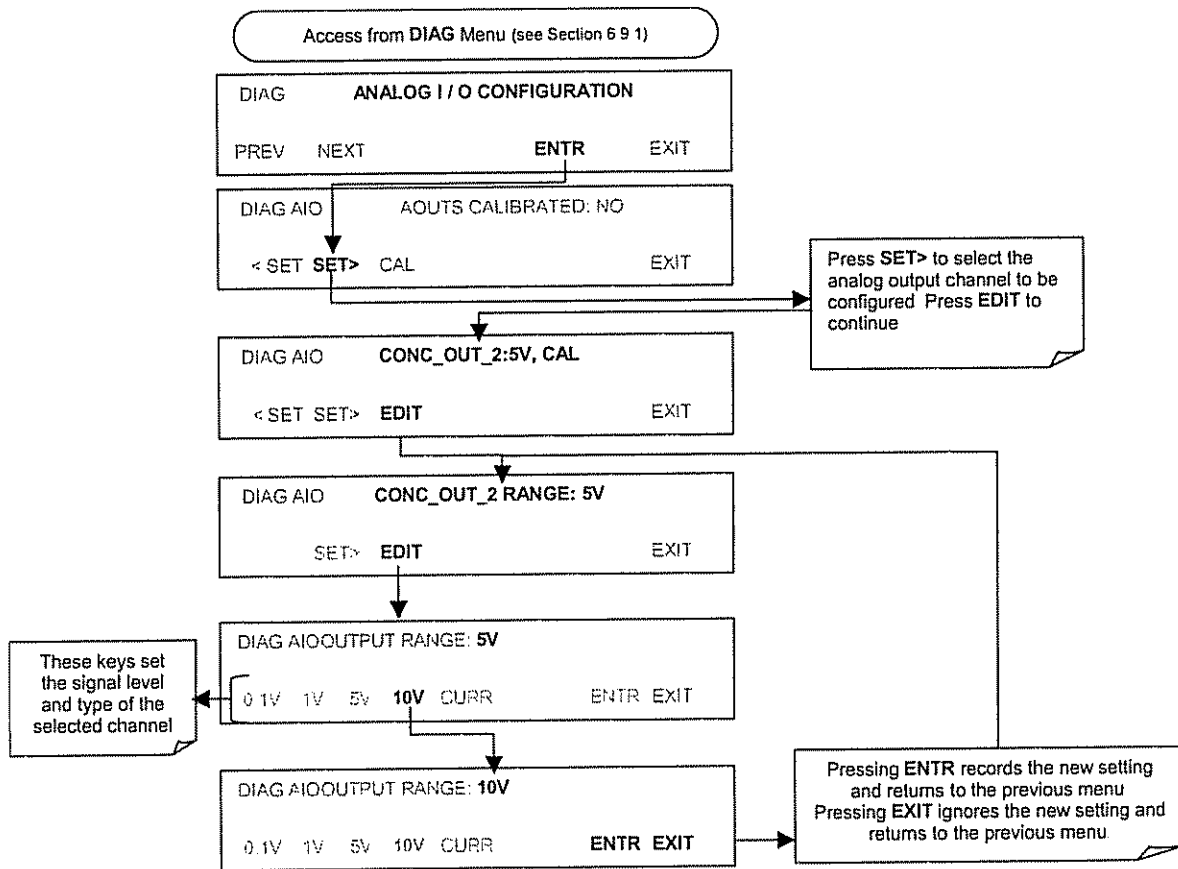

6.9.4.2. Analog Output Calibration Mode

The analog outputs can be calibrated automatically or manually. In its default mode, the instrument is configured for automatic calibration of all channels. Manual calibration should be used for the 0.1V range or in cases where the outputs must be closely matched to the characteristics of the recording device. Outputs configured for automatic calibration can be calibrated as a group or individually. Calibration of the analog outputs needs to be carried out on first startup of the analyzer (performed in the factory as part of the configuration process) or whenever re-calibration is required.

To calibrate the outputs as a group, activate the **ANALOG I/O CONFIGURATION MENU** (see Section 6.9.1), then press:

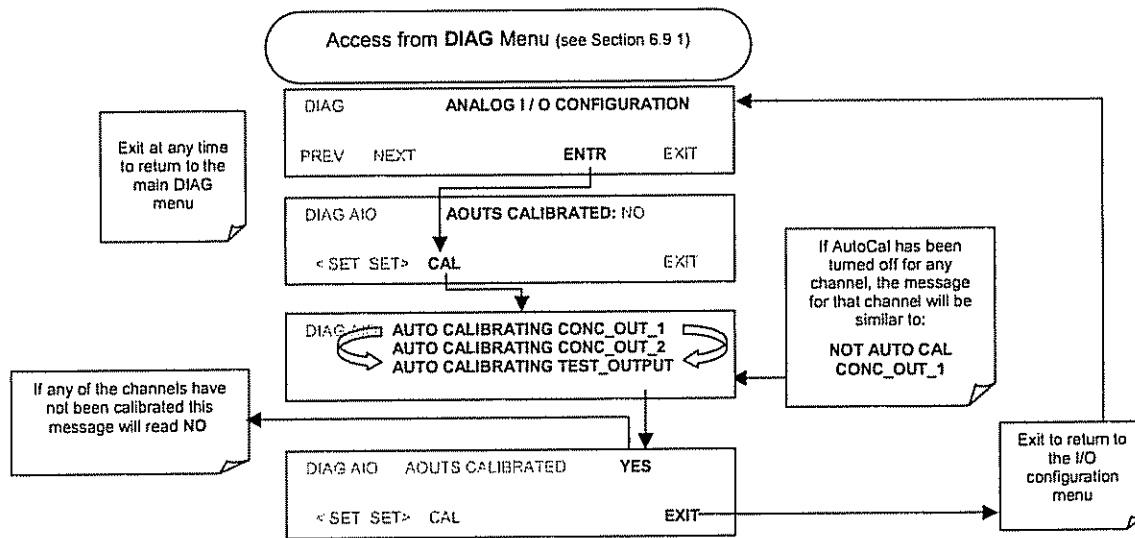

To automatically calibrate an single analog channel, press:

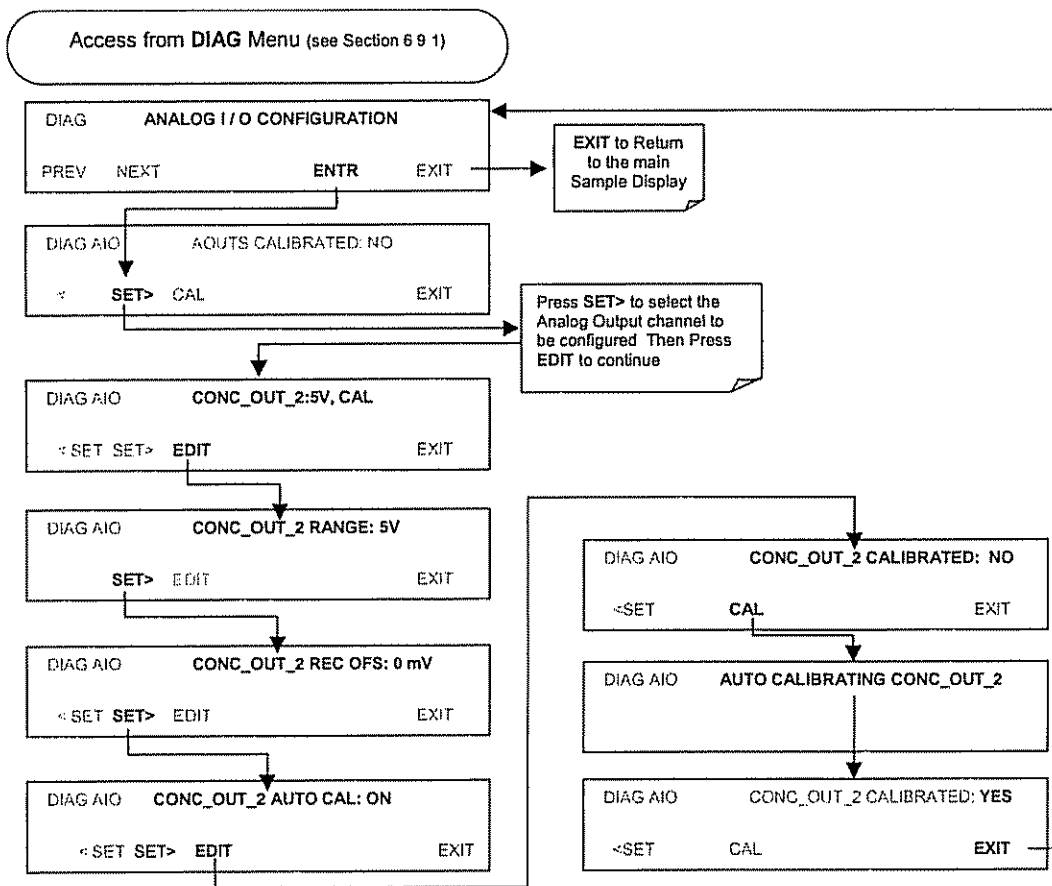

To select manual output calibration for a particular channel, press:

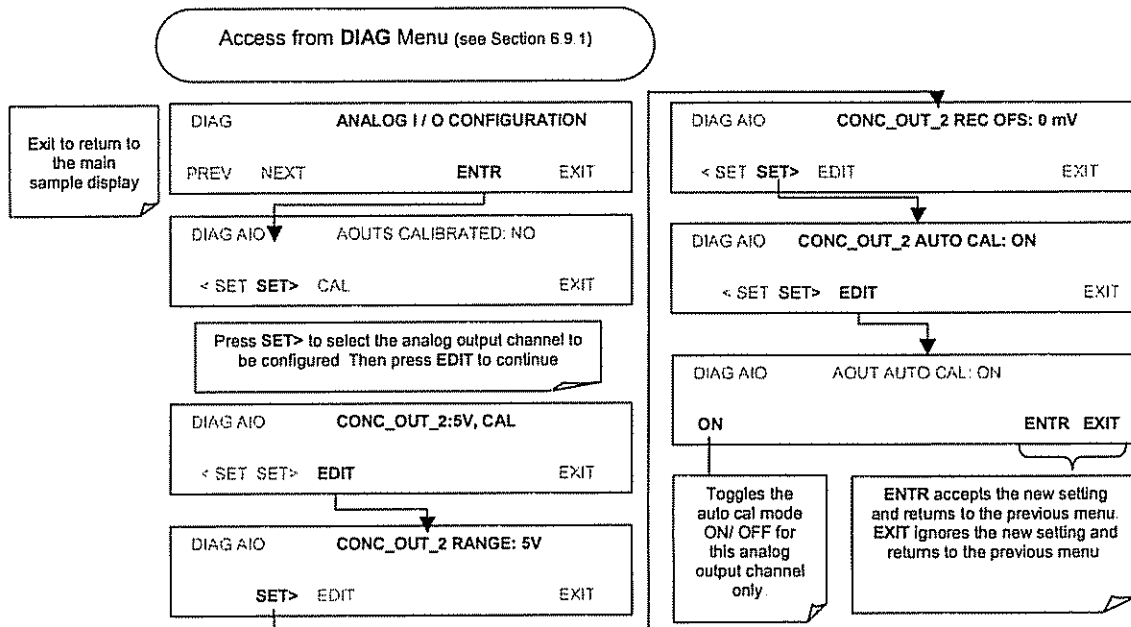

Now the analog output channels should either be automatically calibrated or they should be set to manual calibration, which is described next.

6.9.4.3. Manual Analog Output Calibration and Voltage Adjustment

For highest accuracy, the voltages of the analog outputs can be manually calibrated. Calibration is done through the instrument software with a voltmeter connected across the output terminals (see Figure 6-5). Adjustments are made using the front panel keys by setting the zero-point first and then the span-point (see Table 6-12).

The software allows this adjustment to be made in 100, 10 or 1 count increments.

Table 6-12: Voltage Tolerances for Analog Output Calibration

FULL SCALE	ZERO TOLERANCE	SPAN VOLTAGE	SPAN TOLERANCE
0.1 VDC	±0.0005V	90 mV	±0.001V
1 VDC	±0.001V	900 mV	±0.001V
5 VDC	±0.002V	4500 mV	±0.003V
10 VDC	±0.004V	4500 mV	±0.006V

NOTE

Outputs configured for 0.1V full scale should always be calibrated manually

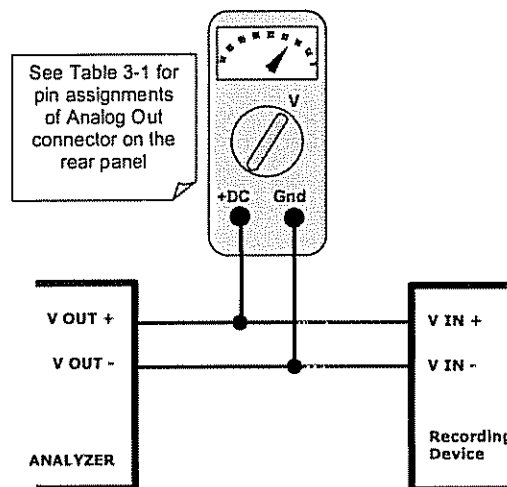
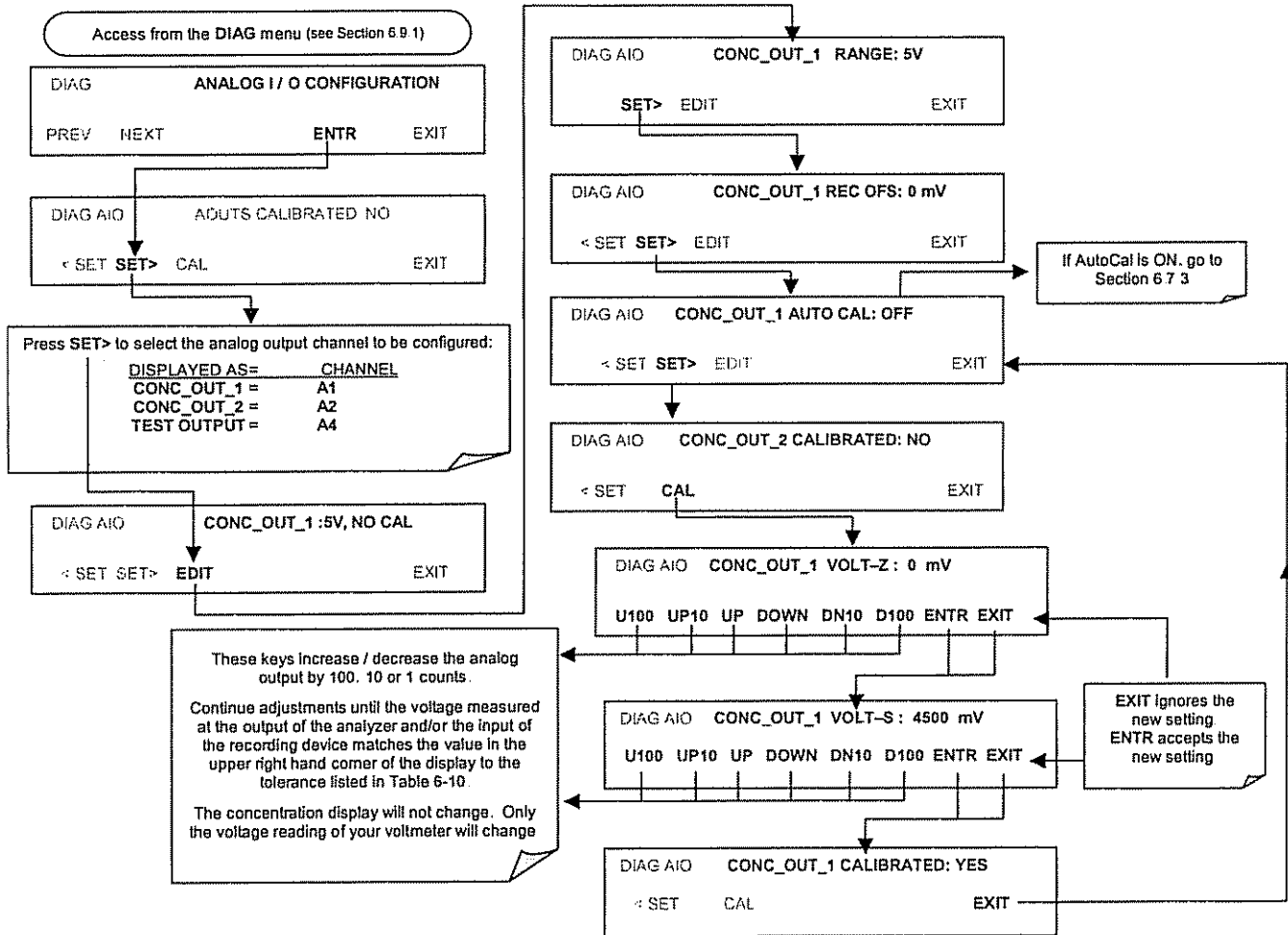

Figure 6-5: Setup for Calibrating Analog Outputs

To make these adjustments, the **AOUT** auto-calibration feature must be turned off (see Section 6.9.4.2). Activate the **ANALOG I/O CONFIGURATION MENU** (see Section 6.9.1), then press:



6.9.4.4. Analog Output Offset Adjustment

Some analog signal recorders require that the zero signal is significantly different from the baseline of the recorder in order to record slightly negative readings from noise around the zero point. This can be achieved in the 6400E by defining a zero offset, a small voltage (e.g., 10% of span), which can be added to the signal of individual output channels by activating the **ANALOG I/O CONFIGURATION MENU** (see Section 6.9.1), then pressing:

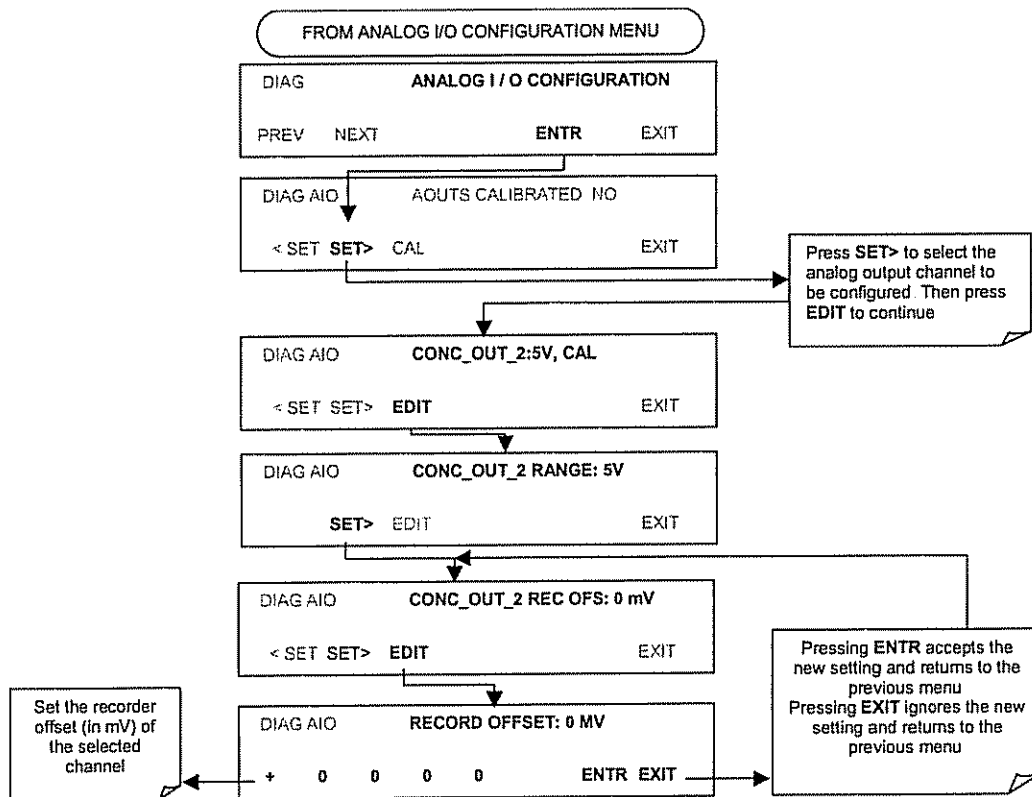

6.9.4.5. Current Loop Output Adjustment

A current loop option is available and can be installed as a retrofit for each of the analog outputs of the analyzer (see Sections 5-2). This option converts the DC voltage analog output to a current signal with 0-20 mA output current. The outputs can be scaled to any set of limits within that 0-20 mA range. However, most current loop applications call for either 2-20 mA or 4-20 mA range. All current loop outputs have a +5% over-range. Ranges with the lower limit set to more than 1 mA (e.g., 2-20 or 4-20 mA) also have a -5% under-range.

To switch an analog output from voltage to current after installing the current output printed circuit assembly, follow the instructions in Section 6.9.4.1 and select **CURR** from the list of options on the "Output Range" menu.

Adjusting the signal zero and span values of the current loop output is done by raising or lowering the voltage of the respective analog output. This proportionally raises or lowers the current produced by the current loop option.

Similar to the voltage calibration, the software allows this current adjustment to be made in 100, 10 or 1 count increments. Since the exact current increment per voltage count varies from output to output and from instrument to instrument, you will need to measure the change in the current with a current meter placed in series with the output circuit (see Figure 6-6).

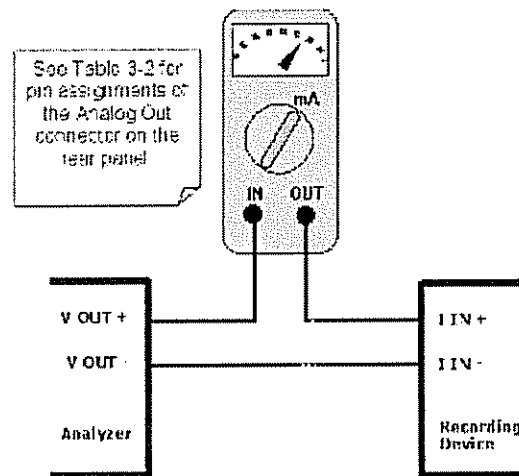
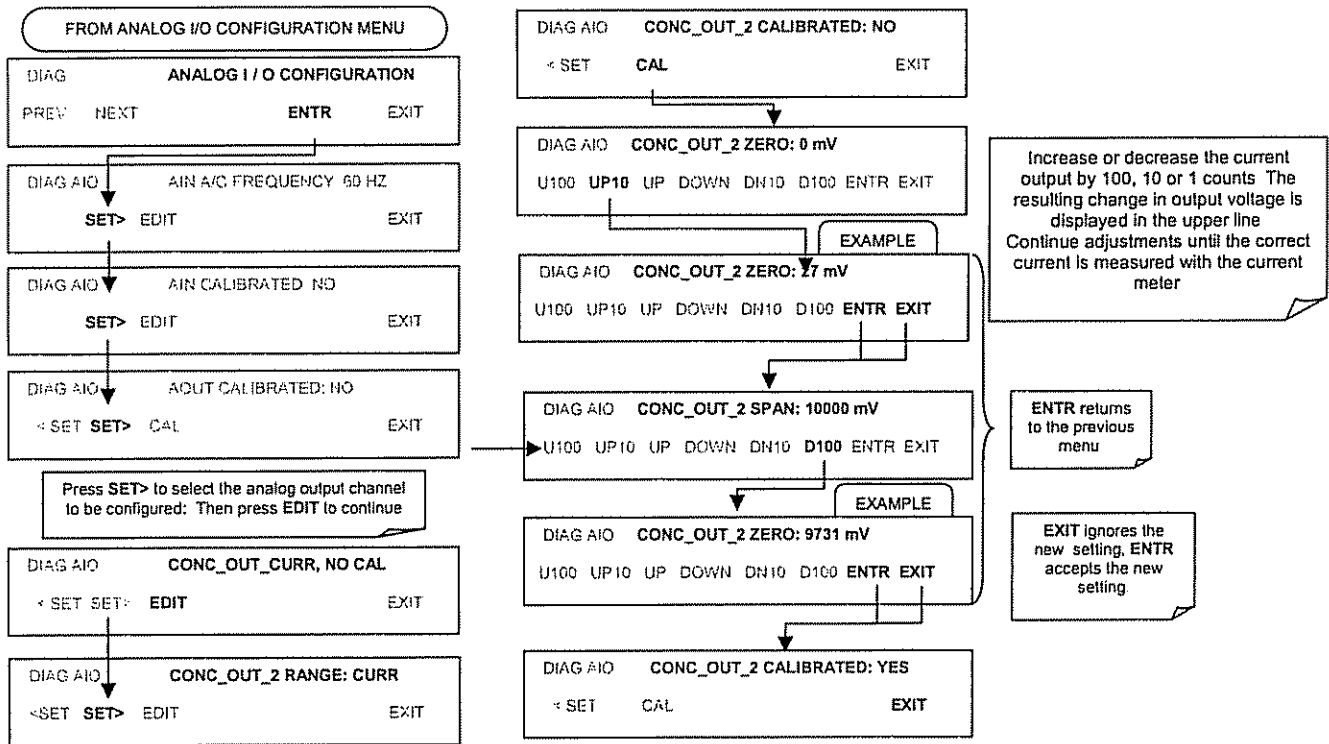

Figure 6-6: Setup for Calibrating Current Outputs

NOTE

Do not exceed 60 V between current loop outputs and instrument ground.

To adjust the zero and span values of the current outputs, activate the **ANALOG I/O CONFIGURATION MENU** (see Section 6.9.1), then press:



If a current meter is not available, an alternative method for calibrating the current loop outputs is to connect a 250 Ω ±1% resistor across the current loop output. Using a voltmeter, connected across the resistor, follow the procedure above but adjust the output to the following values:

Table 6-13: Current Loop Output Calibration with Resistor

FULL SCALE	VOLTAGE FOR 2-20 MA (MEASURED ACROSS RESISTOR)	VOLTAGE FOR 4-20 MA (MEASURED ACROSS RESISTOR)
0%	0.5 V	1.0 V
100%	5.0 V	5.0 V

6.9.4.6. AIN Calibration

This is the sub-menu to conduct the analog input calibration. This calibration should only be necessary after major repair such as a replacement of CPU, motherboard or power supplies. Activate the **ANALOG I/O CONFIGURATION MENU** (see Section 6.9.1), then press:

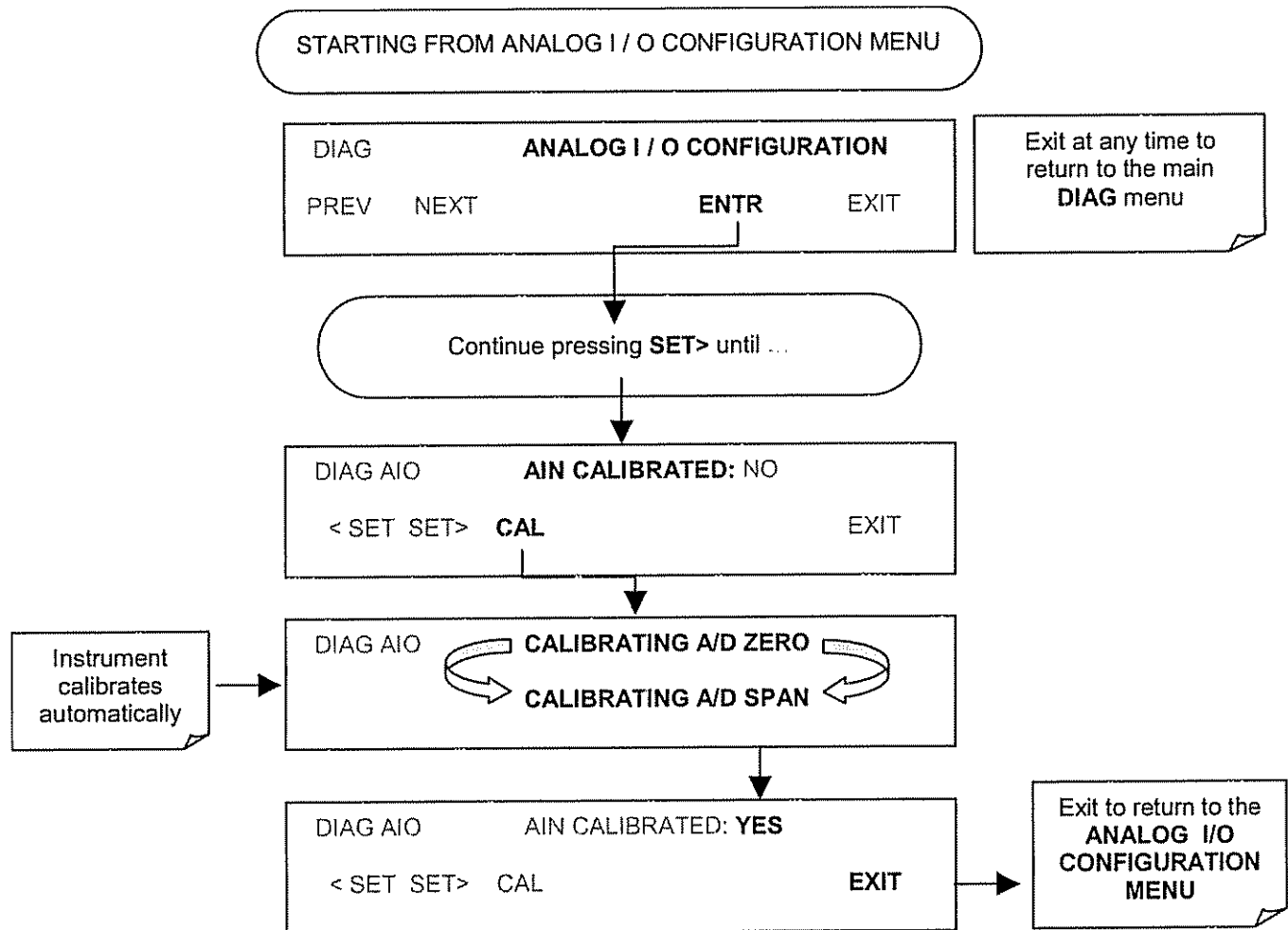

6.9.5. OPTIC TEST

The optic test function tests the response of the PMT sensor by turning on an LED located in the cooling block of the PMT (Fig. 10-15). The analyzer uses the light emitted from the LED to test its photo-electronic subsystem, including the PMT and the current to voltage converter on the pre-amplifier board. To make sure that the analyzer measures only the light coming from the LED, the analyzer should be supplied with zero air. The optic test should produce a PMT signal of about 2000±1000 mV. To activate the electrical test press the following key sequence.

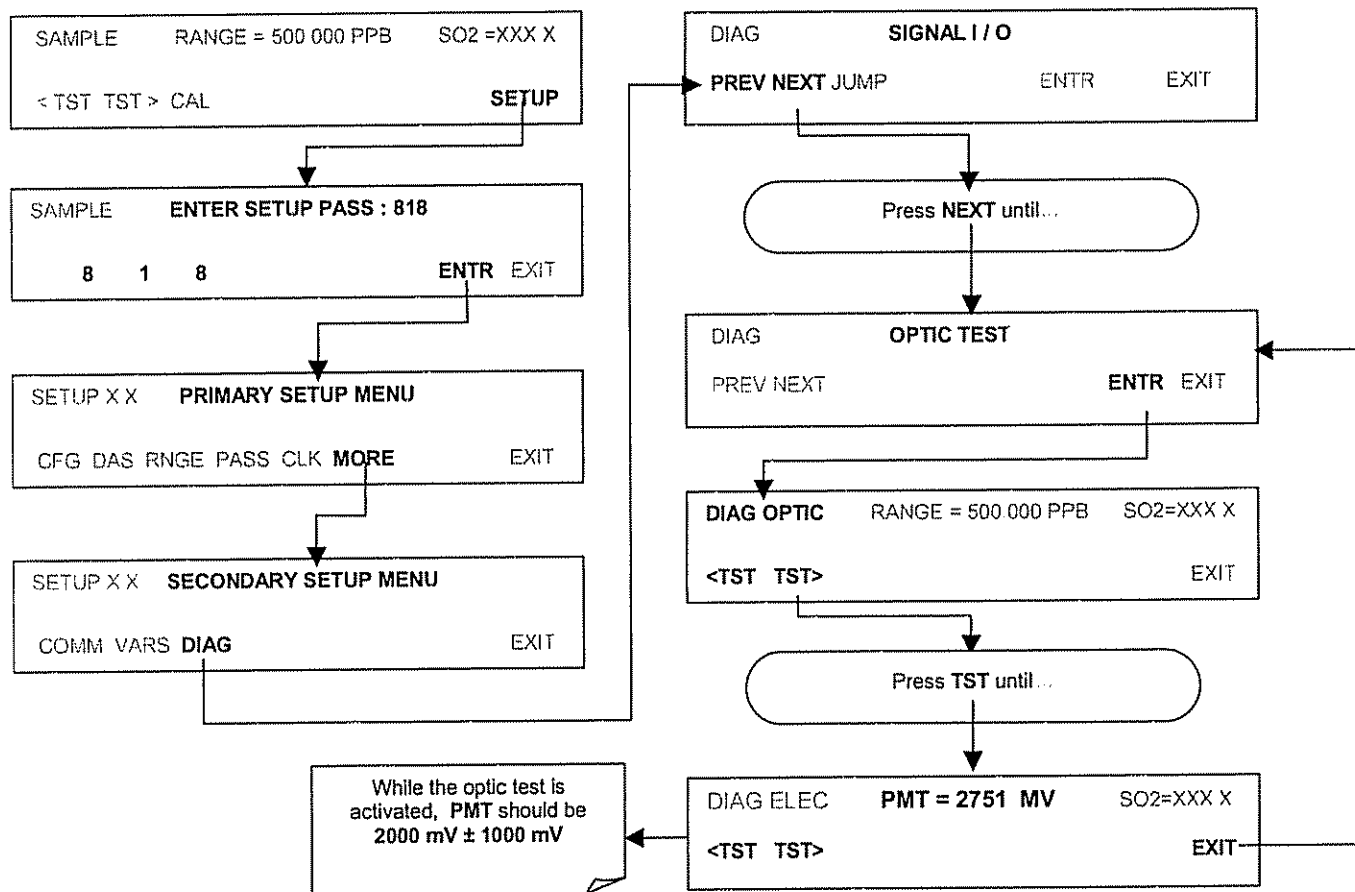

NOTE

This is a coarse test for functionality and not an accurate calibration tool. The resulting PMT signal can vary significantly over time and also changes with low-level calibration.

6.9.6. ELECTRICAL TEST

The electrical test function creates a current, which substitutes the PMT signal, and feeds it into the preamplifier board. This signal is generated by circuitry on the pre-amplifier board itself and tests the filtering and amplification functions of that assembly along with the A/D converter on the motherboard. It does not test the PMT itself. The electrical test should produce a PMT signal of about 2000 ±1000 mV.

To activate the electrical test press the following keys.

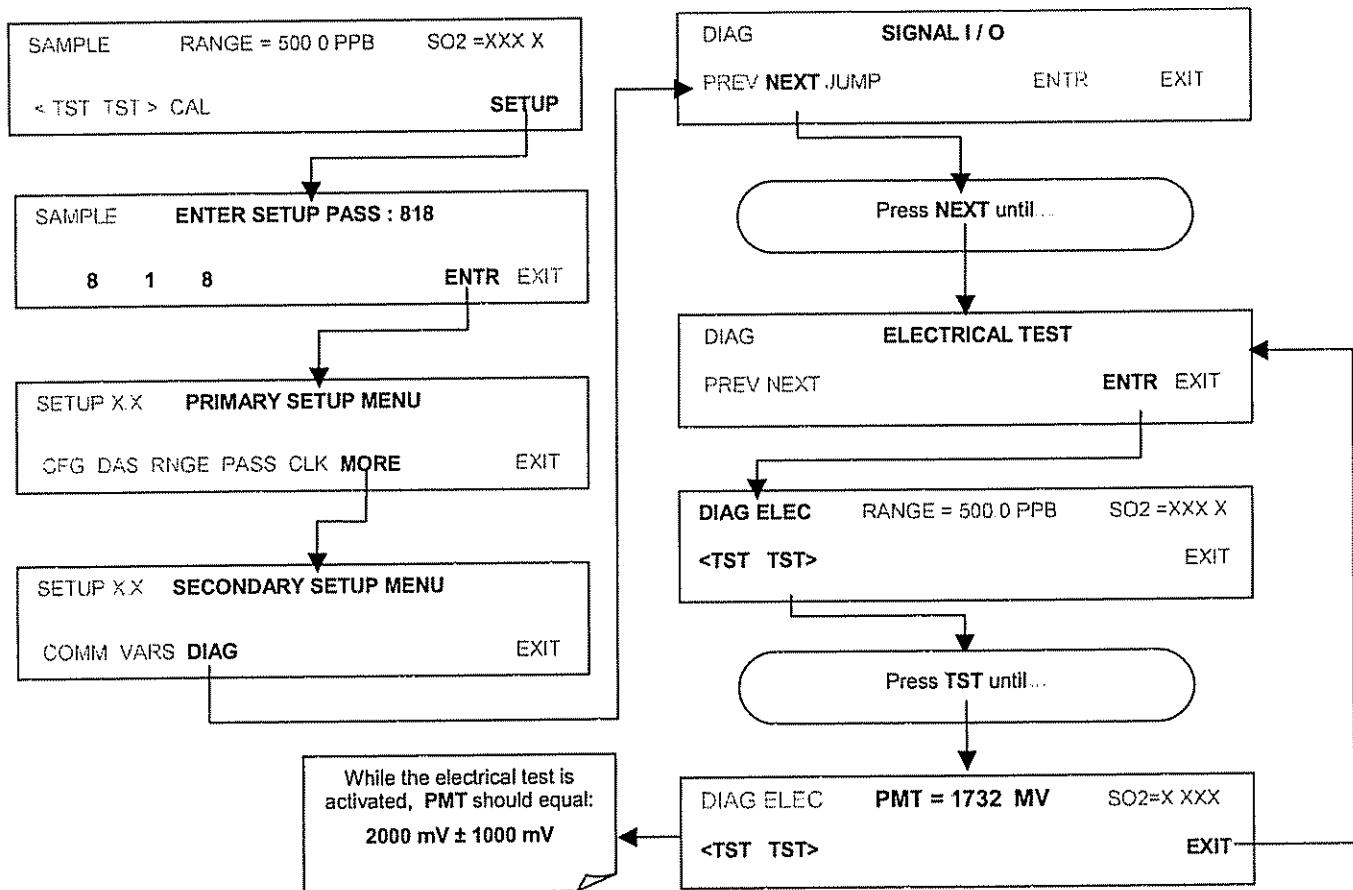

6.9.7. LAMP CALIBRATION

An important factor in accurately determining SO₂ concentration is the amount of UV light available to transform the SO₂ into SO₂* (see Section 10.1.1). The model 6400E compensates for variations in the intensity of the available UV light by adjusting the SO₂ concentration calculation using a ratio (**LAMP RATIO**) that results from dividing the current UV lamp (**UV LAMP**) intensity by a value stored in the CPU's memory (**LAMP_CAL**). Both LAMP Ration and UV Lamp are test functions viewable from the instruments front panel.

To cause the analyzer to measure and record a value for **LAMP_CAL**, press.

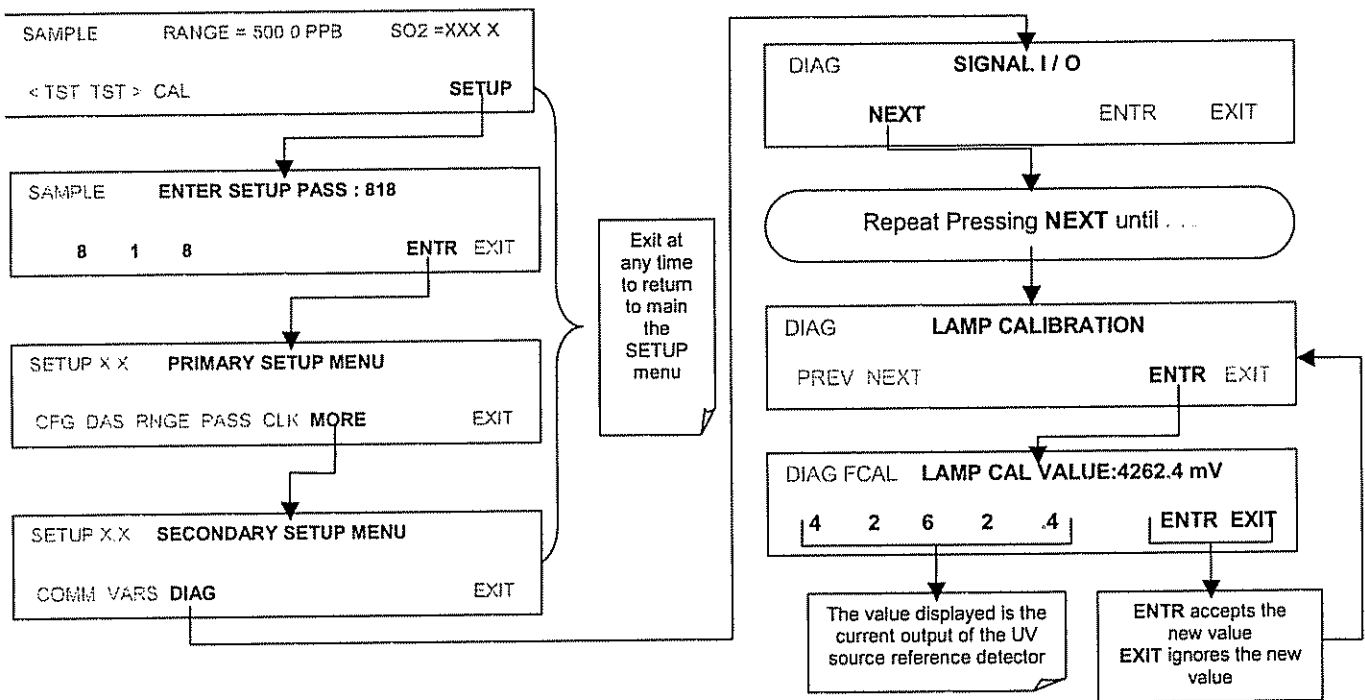

6.9.8. PRESSURE CALIBRATION

A sensor at the exit of the sample chamber continuously measures the pressure of the sample gas. This data is used to compensate the final SO₂ concentration calculation for changes in atmospheric pressure when the instrument's TPC feature is turned on (see Section 10.7.3) and is stored in the CPU's memory as the test function **PRES** (also viewable via the front panel).

To cause the analyzer to measure and record a value for **PRES**, press.

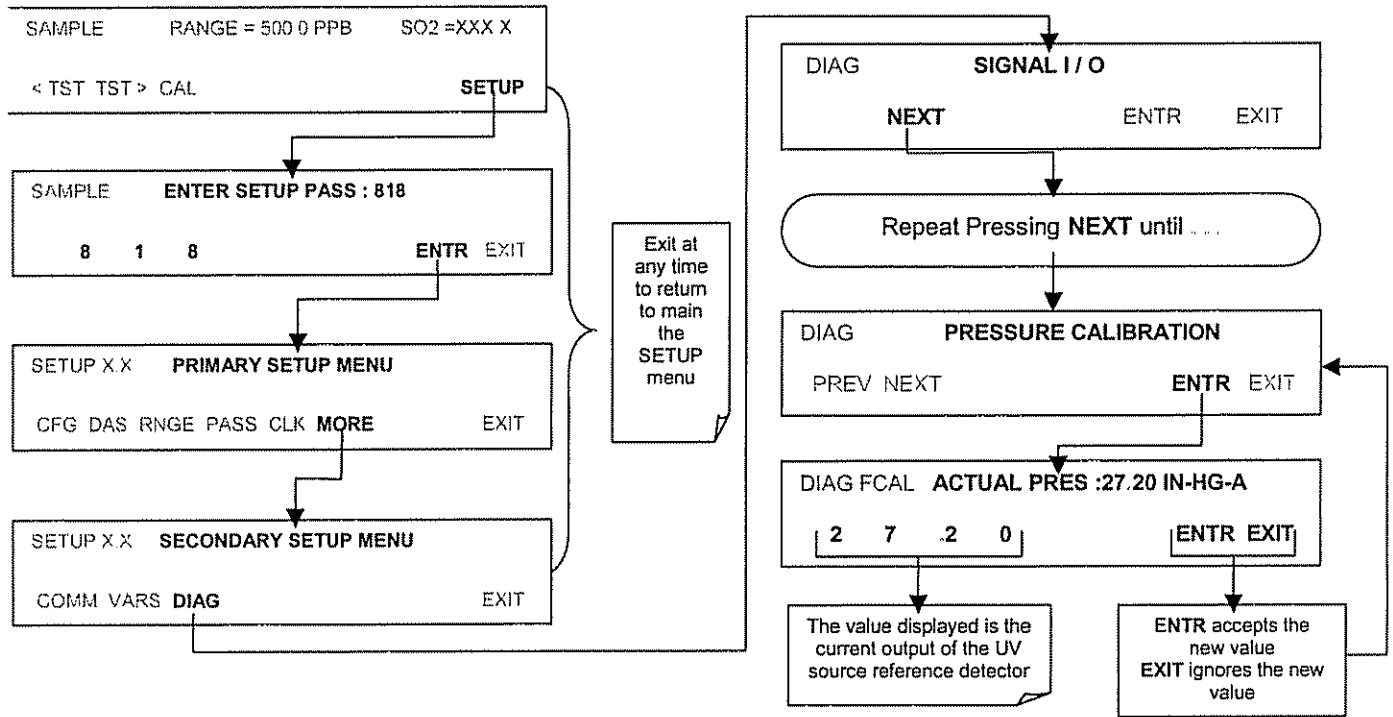

6.9.9. FLOW CALIBRATION

The flow calibration allows the user to adjust the values of the sample flow rates as they are displayed on the front panel and reported through COM ports to match the actual flow rate measured at the sample inlet. This does not change the hardware measurement of the flow sensors, only the software calculated values.

To carry out this adjustment, connect an external, sufficiently accurate flow meter to the sample inlet (see Chapter 11 for more details). Once the flow meter is attached and is measuring actual gas flow, press:

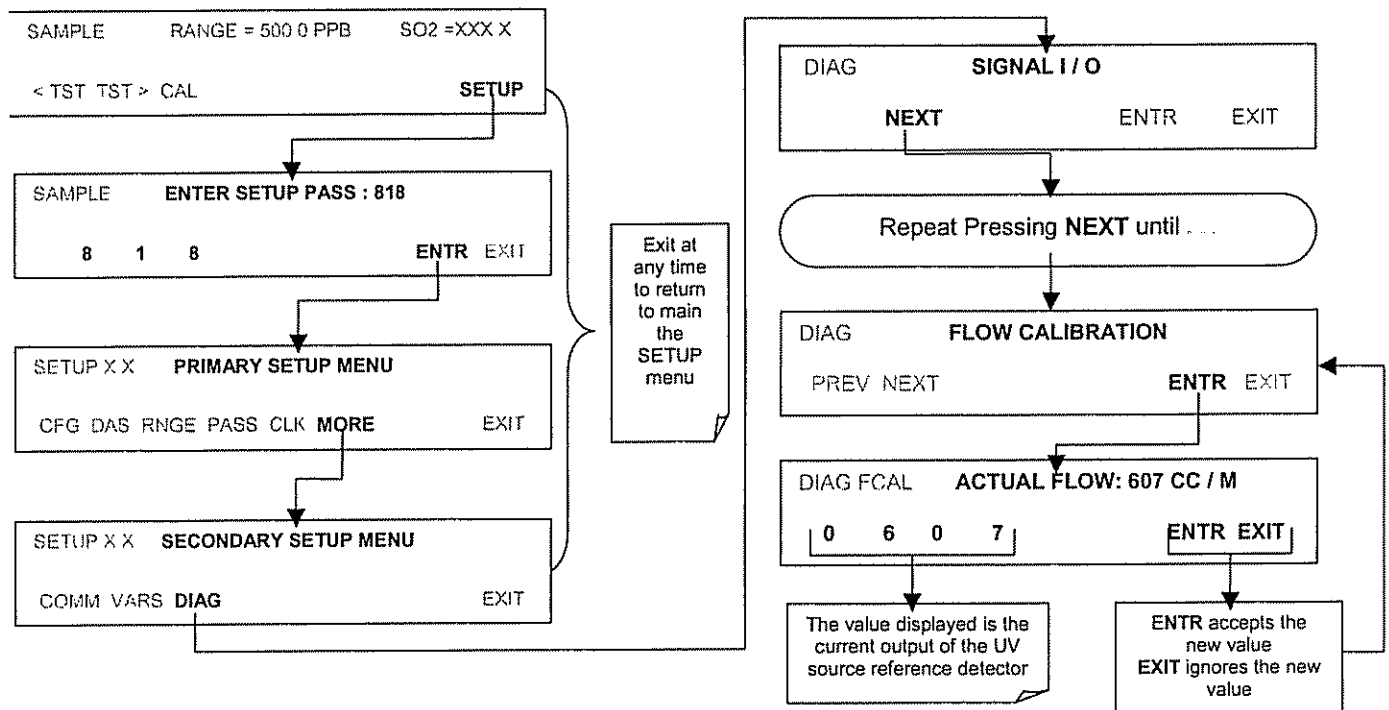

6.9.10. TEST CHANNEL OUTPUT

When activated, output channel **A4** can be used to report one of the test functions viewable from the **SAMPLE** mode display. To activate the A4 channel and select a test function, follow this key sequence:

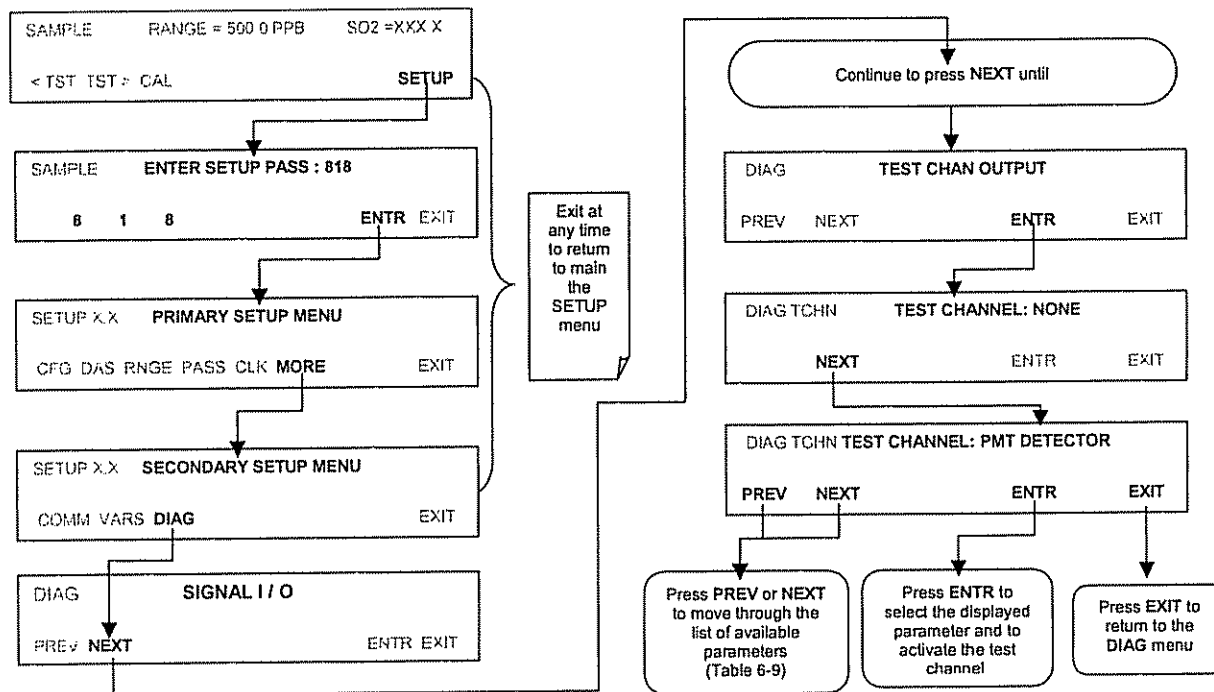

Table 6-14: Test Parameters Available for Analog Output A4

TEST CHANNEL	TEST PARAMETER RANGE
NONE	Test channel is turned off
PMT READING	0-5000 mV
UV READING	0-5000 mV
SAMPLE PRESSURE	0-40 in-Hg-A
SAMPLE FLOW	0-1000 cm ³ /min
RCELL TEMP	0-70° C
CHASSIS TEMP	0-70° C
IZS TEMP	0-70° C
PMT TEMP	0-50° C
HVPS VOLTAGE	0-5000 V

Once a TEST function is selected, the instrument begins to report a signal on the **A3** output and adds **TEST** to the list of test functions viewable on the display (just before the **TIME** test function).

6.10. SETUP – COMM: SETTING UP THE ANALYSER’S COMMUNICATION PORTS

The 6400E is equipped with two serial communication ports located on the rear panel (see Figure 3-1). Both ports operate similarly and give the user the ability to communicate with, issue commands to, and receive data from the analyzer through an external computer system or terminal. By default, both ports operate on the RS-232 protocol.

The COM1 port can also be configured to operate in single or RS-232 multidrop mode (option 62; See Section 5.5.2 and 6.10.7).

The COM2 port, can be configured for standard RS-232 operation, half-duplex RS-485 communication or for access via an LAN by installing the Teledyne Instruments Ethernet interface card (option 63; see Section 5.5.3 and 6.10.6).

A code-activated switch (CAS), can also be used on either port to connect typically between 2 and 16 send/receive instruments (host computer(s) printers, dataloggers, analyzers, monitors, calibrators, etc.) into one communications hub. Contact Teledyne Analytical Instruments sales for more information on CAS systems.

6.10.1. ANALYZER ID

Each type of Teledyne Analytical Instruments analyzer is configured with a default ID code. The default ID code for all 6400E analyzers is **100**. The ID number is only important if more than one analyzer is connected to the same communications channel such as when several analyzers are on the same Ethernet LAN (see Section 6.10.6); in a RS-232 multidrop chain (see Section 6.10.7) or operating over a RS-485 network (see Section 6.10.4). If two analyzers of the same model type are used on one channel, the ID codes of one or both of the instruments needs to be changed so that they are unique to the instruments. To edit the instrument’s ID code, press:

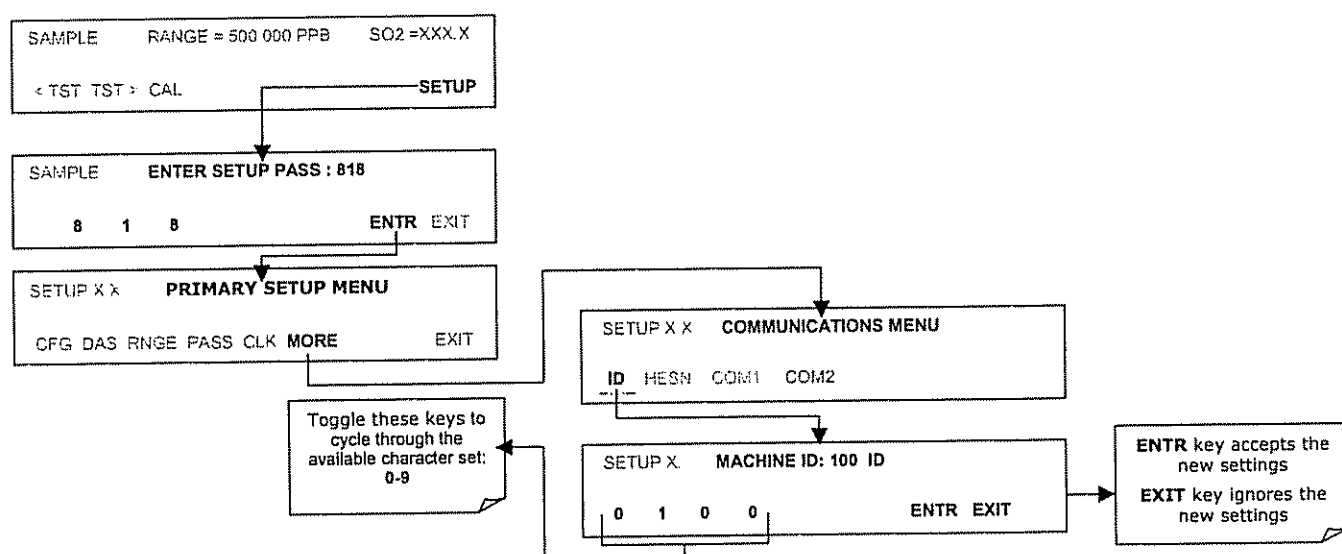

The ID can be any 4 digit number and can also be used to identify analyzers in any number of ways (e.g. location numbers, company asset number, etc.)

6.10.2. COM PORT DEFAULT SETTINGS

As received from the factory, the analyzer is set up to emulate a DCE or modem, with pin 3 of the DB-9 connector designated for receiving data and pin 2 designated for sending data.

- **COM1:** RS-232 (fixed), DB-9 male connector.
 - **Baud rate:** 19200 bits per second (baud).
 - **Data Bits:** 8 data bits with 1 stop bit.
 - **Parity:** None.
- **COM2:** RS-232 (configurable), DB-9 female connector.
 - **Baud rate:** 115000 bits per second (baud).
 - **Data Bits:** 8 data bits with 1 stop bit.
 - **Parity:** None.

CAUTION

Cables that appear to be compatible because of matching connectors may incorporate internal wiring that make the link inoperable. Check cables acquired from sources other than Teledyne Instruments for pin assignments before using.

6.10.3. RS-232 COM PORT CABLE CONNECTIONS

In its default configuration, the 6400E analyzer has two available RS-232 Com ports accessible via 2 DB-9 connectors on the back panel of the instrument. The COM1 connector is a male DB-9 connector and the COM2 is a female DB9 connector.

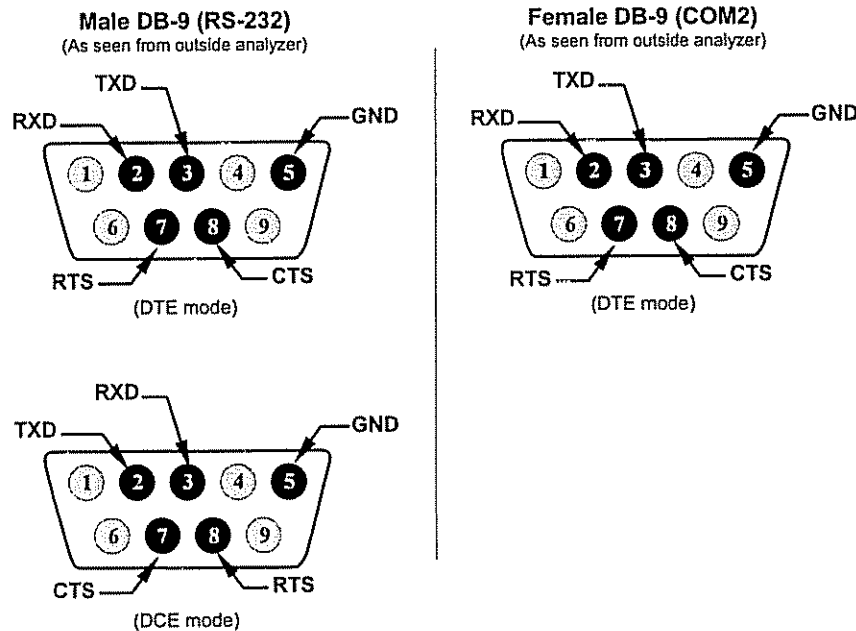

Figure 6-7: Back Panel connector Pin-Outs for COM1 & COM2 in RS-232 mode.

The signals from these two connectors are routed from the motherboard via a wiring harness to two 10-pin connectors on the CPU card, CN3 (COM1) and CN4 (COM2).

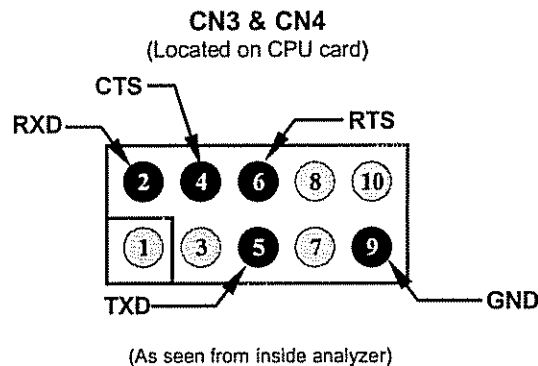

Figure 6-8: CPU connector Pin-Outs for COM1 & COM2 in RS-232 mode.

Teledyne Instruments offers two mating cables, one of which should be applicable for your use.

- Part number WR000077, a DB-9 female to DB-9 female cable, 6 feet long. Allows connection of COM1 with the serial port of most personal computers. Also available as Option 60 (see Section 5.5.1).
- Part number WR000024, a DB-9 female to DB-25 male cable. Allows connection to the most common styles of modems (e.g. Hayes-compatible) and code activated switches.

Both cables are configured with straight-through wiring and should require no additional adapters.

To assist in properly connecting the serial ports to either a computer or a modem, there are activity indicators just above the COM1 port. Once a cable is connected between the analyzer and a computer or modem, both the red and green LEDs should be on. If the lights for COM 1 are not lit, use small switch on the rear panel to switch it between DTE and DCE modes (see Section 6.10.5). If both LEDs are still not illuminated, check the cable for proper wiring.

The two LEDs located over COM2 are currently deactivated. If you have problems getting COM2 to activate, it may be necessary to install a null-modem cable (contact customer service for information).

6.10.4. RS-485 CONFIGURATION OF COM2

As delivered from the factory, COM2 is configured for RS-232 communications. This port can be re-configured for operation as a non-isolated, half-duplex RS-485 port capable of supporting up to 32 instruments with a maximum distance between the host and the furthest instrument being 4000 feet. If you require full-duplex or isolated operation, please contact Teledyne Instruments Customer Service.

- To reconfigure COM2 as an RS-285 port set switch 6 of SW1 to the ON position(see Figure 6-9).
- The RS-485 port can be configured with or without a 150 Ω termination resistor. To include the resistor, install jumper at position JP3 on the CPU board (see Figure 6-9). To configure COM2 as an un-terminated RS-485 port leave JP3 open.

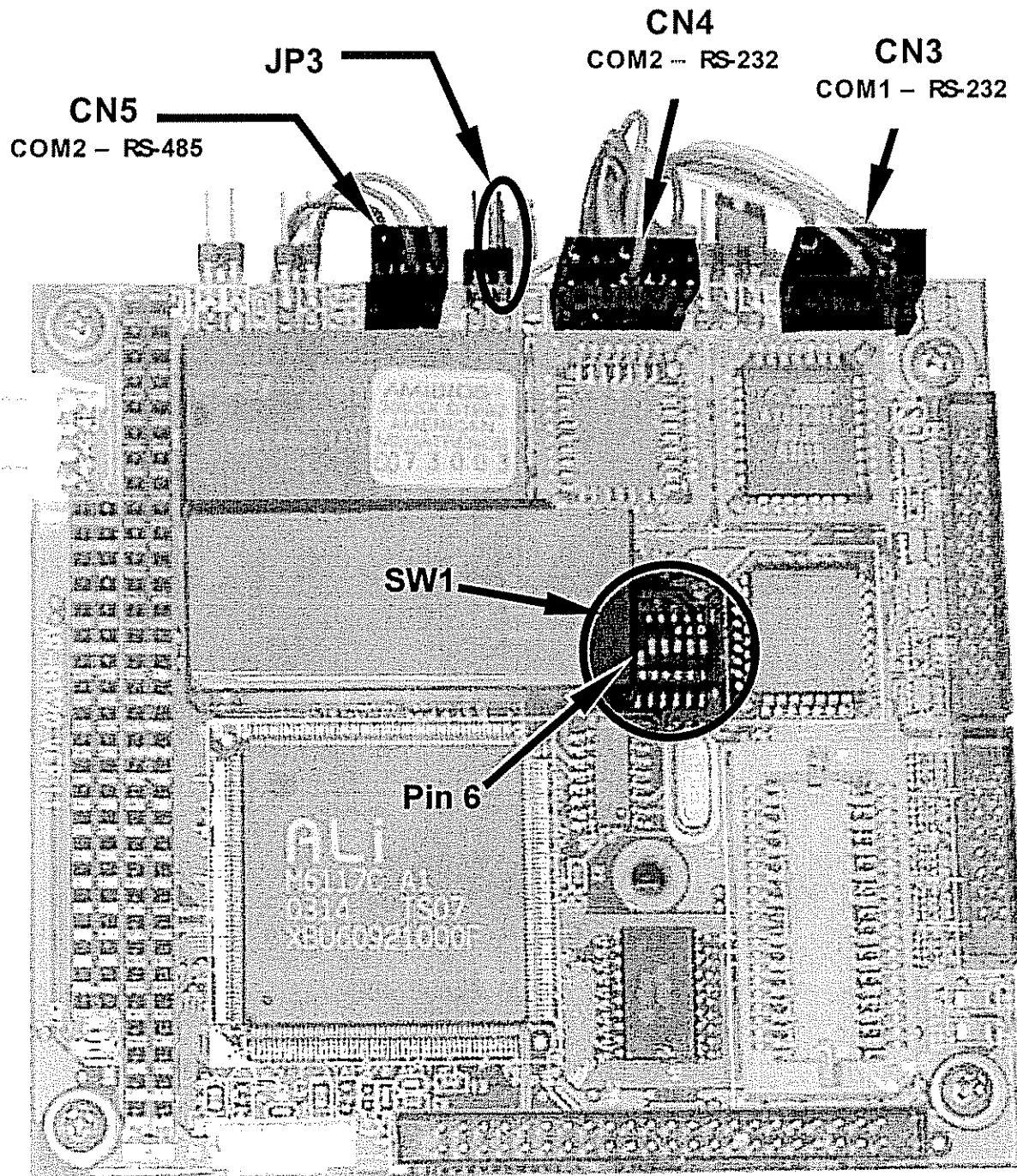

Figure 6-9: CPU card Locations of RS-232/486 Switches, Connectors and Jumpers

When COM2 is configured for RS-485 operation the port uses the same female DB-9 connector on the back of the instrument as when Com2 is configured for RS-232 operation, however, the pin assignments are different.

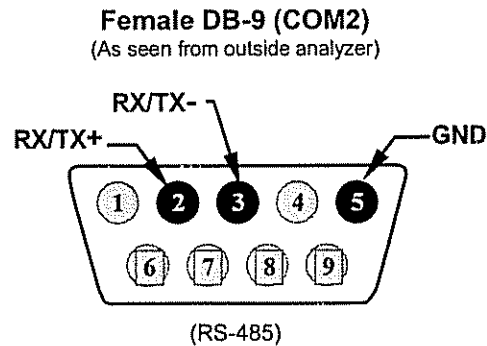

Figure 6-10: Back Panel connector Pin-Outs for COM2 in RS-485 mode.

The signal from this connector is routed from the motherboard via a wiring harness to a 6-pin connector on the CPU card, CN5.

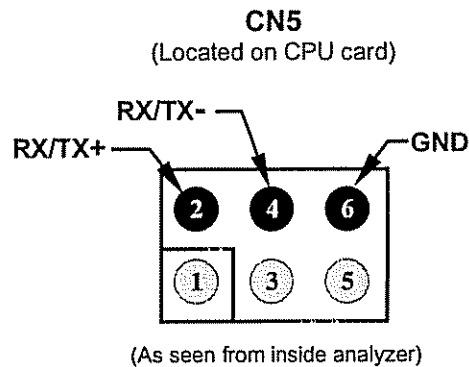

Figure 6-11: CPU connector Pin-Outs for COM2 in RS-485 mode.

6.10.5. DTE AND DCE COMMUNICATION

RS-232 was developed for allowing communications between data terminal equipment (DTE) and data communication equipment (DCE). Basic terminals always fall into the DTE category whereas modems are always considered DCE devices. The difference between the two is the pin assignment of the Data Receive and Data Transmit functions.

- DTE devices receive data on pin 2 and transmit data on pin 3.
- DCE devices receive data on pin 3 and transmit data on pin 2.

To allow the analyzer to be used with terminals (DTE), modems (DCE) and computers (which can be either), a switch mounted below the serial ports on the rear panel allows the user to set the configuration of COM1 for one of these two modes. This switch exchanges the receive and transmit lines on COM1 emulating a cross-over or null-modem cable. The switch has no effect on COM2.

6.10.6. ETHERNET CARD CONFIGURATION

When equipped with the optional Ethernet interface, the analyzer can be connected to any standard 10BaseT Ethernet network via low-cost network hubs, switches or routers. The interface operates as a standard TCP/IP device on port 3000. This allows a remote computer to connect through the internet to the analyzer using APICOM, terminal emulators or other programs.

The firmware on board the Ethernet card automatically sets the communication modes and baud rate (115 200 kBaud) for the **COM2** port. Once the Ethernet option is installed and activated, the **COM2** submenu is replaced by a new submenu, **INET**. This submenu is used to manage and configure the Ethernet interface with your LAN or Internet Server(s).

The card has four LEDs that are visible on the rear panel of the analyzer, indicating its current operating status.

Table 6-15: Ethernet Status Indicators

LED	FUNCTION
LNK (green)	ON when connection to the LAN is valid.
ACT (yellow)	Flickers on any activity on the LAN.
TxD (green)	Flickers when the RS-232 port is transmitting data.
RxD (yellow)	Flickers when the RS-232 port is receiving data.

6.10.6.1. Ethernet Card COM2 Communication Modes and Baud Rate

The firmware on board the Ethernet card automatically sets the communication modes for the COM2 port. The baud rate is also automatically set at 115 200 kBaud.

6.10.6.2. Configuring the Ethernet Interface Option using DHCP

The Ethernet option for you 6400E uses Dynamic Host Configuration Protocol (DHCP) to automatically configure its interface with your LAN. This requires your network servers also be running DHCP. The analyzer will do this the first time you turn the instrument on after it has been physically connected to your network. Once the instrument is connected and turned on it will appear as an active device on your network without any extra set up steps or lengthy procedures.

Should you need to, the following Ethernet configuration properties are viewable via the analyzer's front panel.

Table 6-16: LAN/Internet Configuration Properties

PROPERTY	DEFAULT STATE		DESCRIPTION
DHCP STATUS	On	Editable	This displays whether the DHCP is turned ON or OFF.
INSTRUMENT IP ADDRESS	Configured by DHCP	EDIT key disabled when DHCP is ON	This string of four packets of 1 to 3 numbers each (e.g. 192.168.76.55.) is the address of the analyzer itself.
GATEWAY IP ADDRESS	Configured by DHCP	EDIT key disabled when DHCP is ON	A string of numbers very similar to the Instrument IP address (e.g. 192.168.76.1.) that is the address of the computer used by your LAN to access the Internet.
SUBNET MASK	Configured by DHCP	EDIT key disabled when DHCP is ON	Also a string of four packets of 1 to 3 numbers each (e.g. 255.255.252.0) that defines that identifies the LAN the device is connected to. All addressable devices and computers on a LAN must have the same subnet mask. Any transmissions sent devices with different assumed to be outside of the LAN and are routed through gateway computer onto the Internet.
TCP PORT¹	3000	Editable	This number defines the terminal control port by which the instrument is addressed by terminal emulation software, such as Internet or Teledyne Instruments' APICOM.
HOST NAME	6400E	Editable	The name by which your analyzer will appear when addressed from other computers on the LAN or via the Internet. While the default setting for all Teledyne Instruments 6400E analyzers is "6400E" the host name may be changed to fit customer needs.
¹ Do not change the setting for this property unless instructed to by Teledyne Instruments Customer Service personnel.			

NOTE

It is a good idea to check these settings the first time you power up your analyzer after it has been physically connected to the LAN/Internet to make sure that the DHCP has successfully downloaded the appropriate information from you network server(s).

If the gateway IP, instrument IP and the subnet mask are all zeroes (e.g. "0.0.0.0"), the DHCP was not successful.

You may have to manually configure the analyzer's Ethernet properties. See your network administrator.

To view the above properties, press:

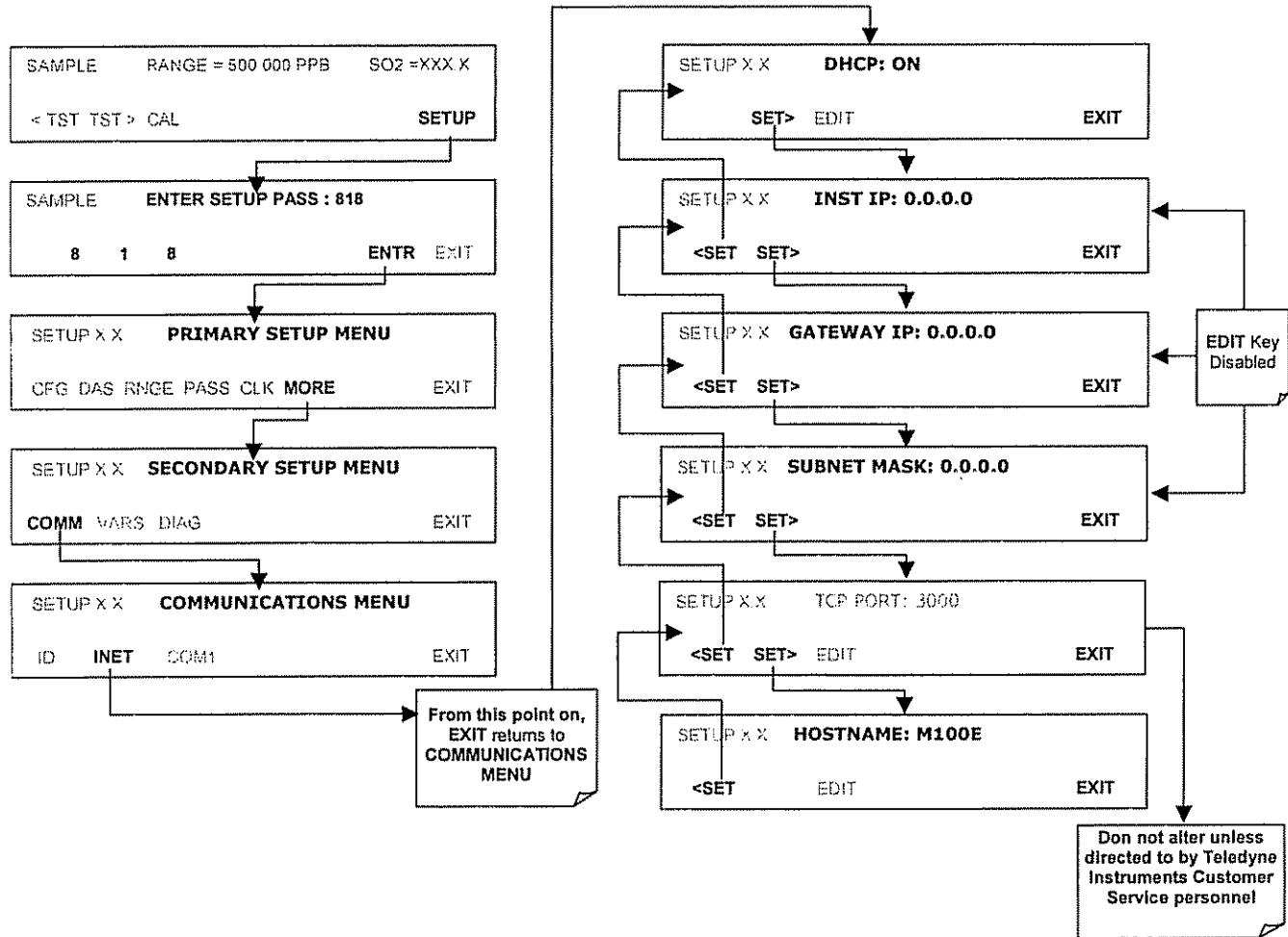

6.10.6.3. Manually Configuring the Network IP Addresses

There are several circumstances when you may need to manually configure the interface settings of the analyzer's Ethernet card. The **INET** sub-menu may also be used to edit the Ethernet card's configuration properties

- Your LAN is not running a DHCP software package,
- The DHCP software is unable to initialize the analyzer's interface;
- You wish to program the interface with a specific set of IP addresses that may not be the ones automatically chosen by DHCP.

Editing the Ethernet Interface properties is a two step process.

STEP 1: Turn DHCP OFF: While DHCP is turned **ON**, the ability to manually set **INSTRUMENT IP**, **GATEWAY IP** and **SUBNET MASK** is disabled

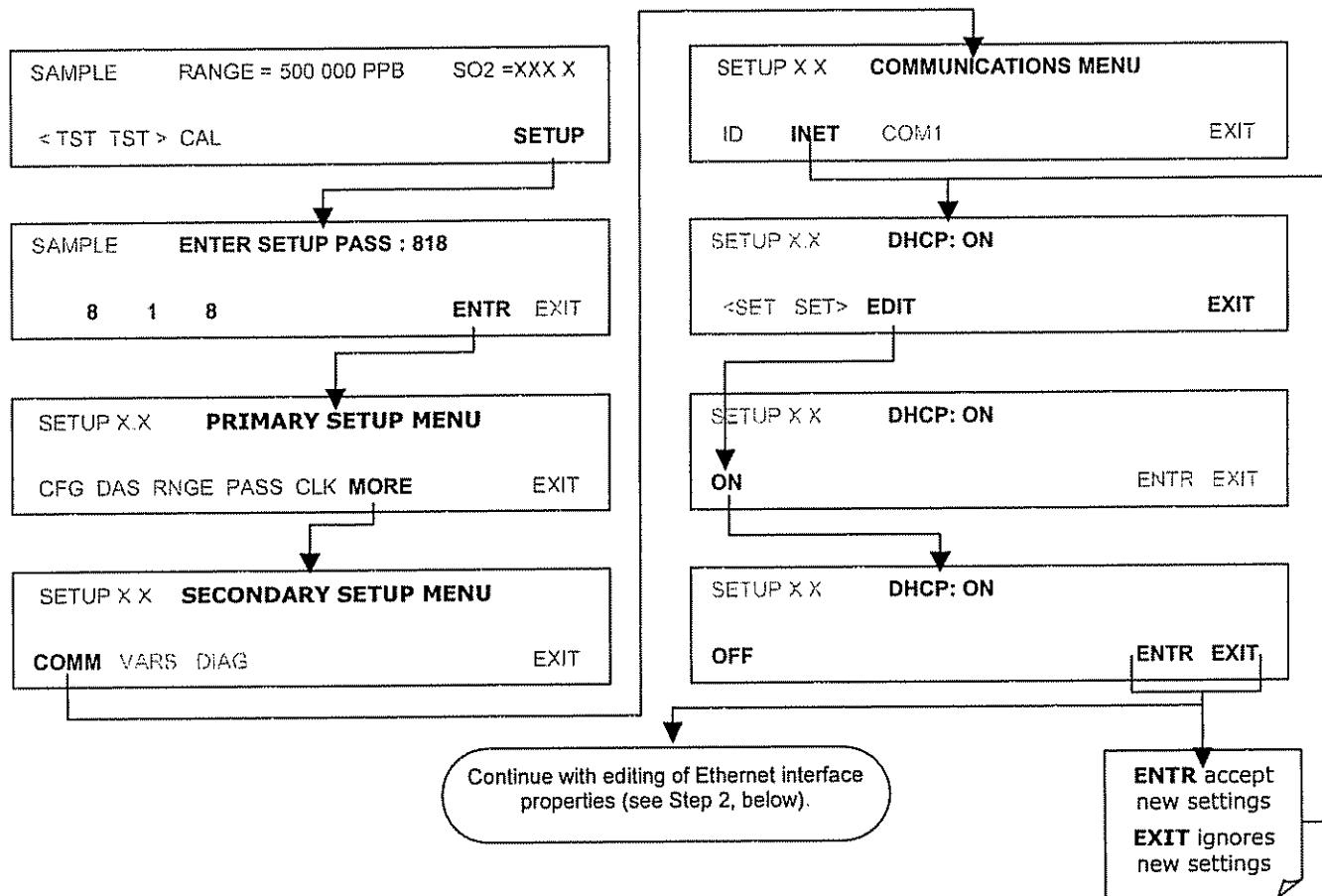

STEP 2: Configure the **INSTRUMENT IP**, **GATEWAY IP** and **SUBNET MASK** addresses by pressing:

Internet Configuration Keypad Functions

KEY	FUNCTION
[0]	Press this key to cycle through the range of numerals and available characters ("0-9" & ".")
<CH CH>	Moves the cursor one character left or right.
DEL	Deletes a character at the cursor location.
ENTR	Accepts the new setting and returns to the previous menu.
EXIT	Ignores the new setting and returns to the previous menu.

Some keys only appear as needed.

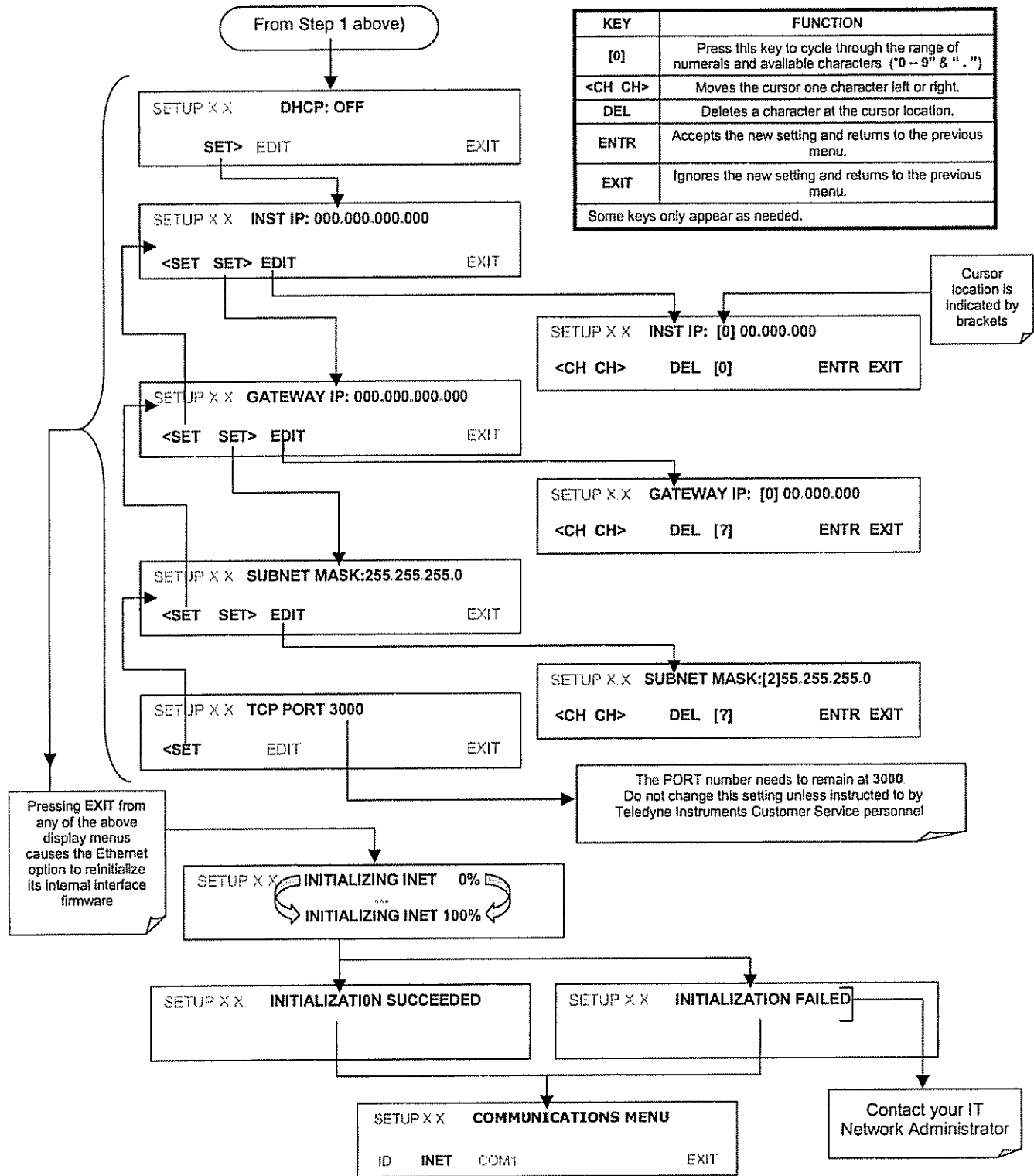

6.10.6.4. Changing the Analyzer's HOSTNAME

The **HOSTNAME** is the name by which the analyzer appears on your network. The default name for all Teledyne Instruments Model 6400E analyzers is **100E**. To change this name (particularly if you have more than one Model 6400E analyzer on your network), press.

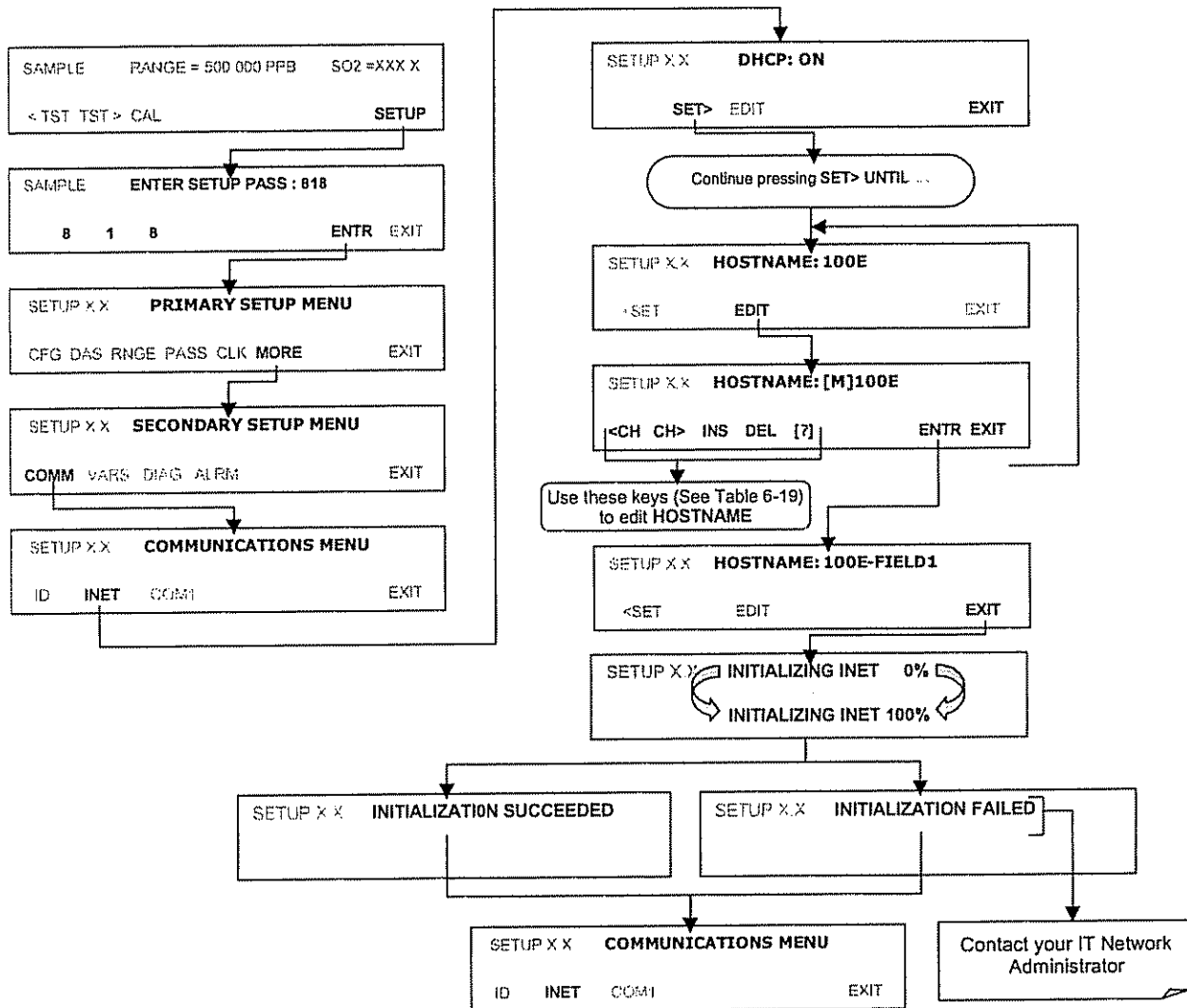

Table 6-17: Internet Configuration Keypad Functions

KEY	FUNCTION
<CH	Moves the cursor one character to the left.
CH>	Moves the cursor one character to the right.
INS	Inserts a character before the cursor location.
DEL	Deletes a character at the cursor location.
[?]	Press this key to cycle through the range of numerals and characters available for insertion. 0-9, A-Z, space ' ~ ! @ # \$ % ^ & * () - _ = + [] { } < > \ ; : , . / ?
ENTR	Accepts the new setting and returns to the previous menu.
EXIT	Ignores the new setting and returns to the previous menu.
Some keys only appear as needed.	

6.10.7. MULTIDROP RS-232 SET UP

The RS-232 multidrop consists of a printed circuit assembly that plugs onto the CN3, CN4, and CN5 connectors of the CPU card (see Figure 6-12) and the cabling to connect it to the analyzer's motherboard. This PCA includes all circuitry required to enable your analyzer for multidrop operation. It converts the instrument's COM1 port to multidrop configuration allowing up to eight analyzers to be connected the same I/O port of the host computer.

Because both of the DB9 connectors on the analyzer's back panel are needed to construct the multidrop chain, COM2 is no longer available for separate RS-232 or RS-485 operation, however, with the addition of an Ethernet Option (option 63, see Sections 5.5.3 and 6.10.6) the COM2 port is available for communication over a 10BaseT LAN.

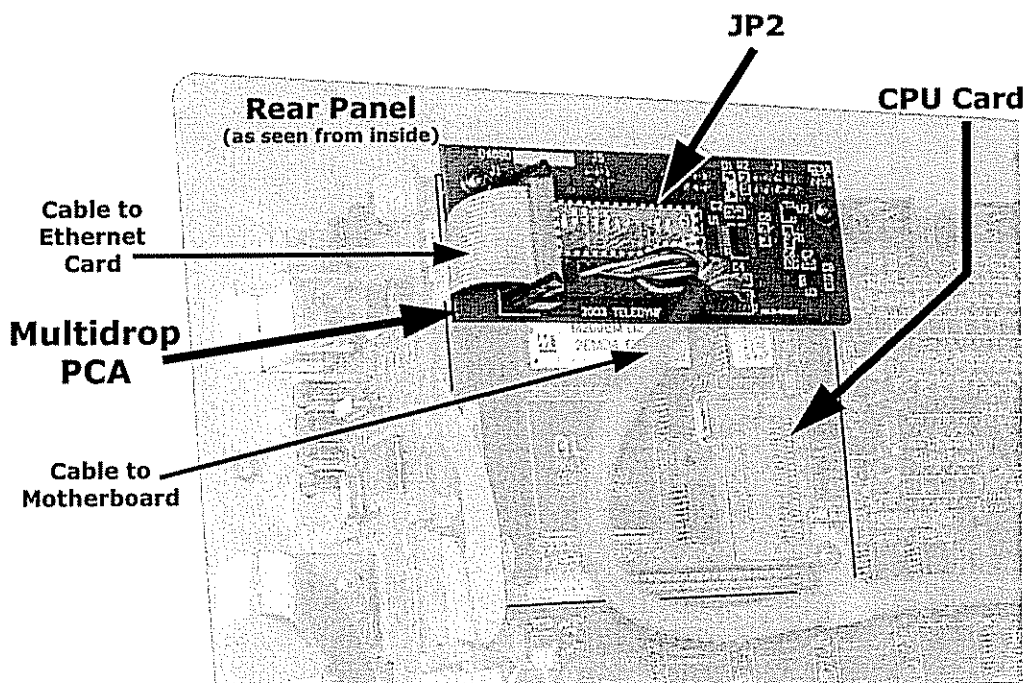

Figure 6-12: Location of JP2 on RS232-Multidrop PCA (option 62)

Each analyzer in the multidrop chain must have:

- One Teledyne Analytical Instruments option 62 Installed.
- One 6' straight-through, DB9 male → DB9 Female cable (Teledyne Instruments P/N WR0000101) is required for each analyzer.

To set up the network, for each analyzer:

4. Turn the analyzer on and change its ID code (see Section 6.10.1) to a unique 4-digit number.
5. Remove the top cover (see Section 3.1) of the analyzer and locate JP2 on the multidrop PCA (see Figure 6-12)
6. Make sure that the jumpers are in place connection pins 9 ↔ 10 and 11 ↔ 12.

7. If the analyzer is to be the last instrument on the chain, make sure a jumper is in place connecting pins 21 ↔ 22.
8. If you are adding an analyzer to the end of an already existing chain, don't forget to remove JP2, pins 21 ↔ 22 on the multidrop PCA on the analyzer that was previous the last instrument in the chain.
9. Close the instrument.
10. Using straight-through, DB9 male → DB9 Female cables, interconnect the host and the analyzers as shown in Figure 6-13.

NOTE:

Teledyne Analytical Instruments recommends setting up the first link, between the Host and the first analyzer and testing it before setting up the rest of the chain.

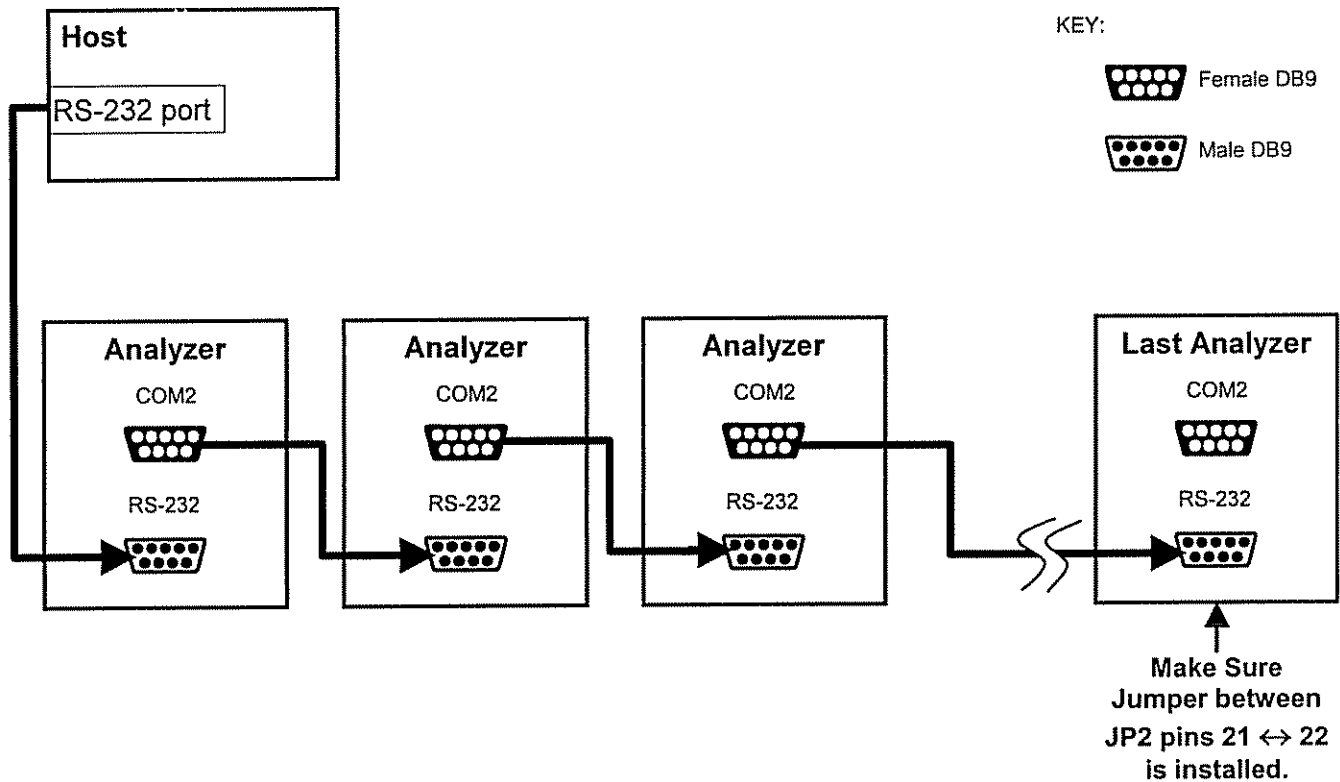

Figure 6-13: RS232-Multidrop PCA Host/Analyzer Interconnect Diagram

6.10.8. COM PORT COMMUNICATION MODES

Each of the analyzer's serial ports can be configured to operate in a number of different modes, which are listed in the following table. Each COM port needs to be configured independently.

Table 6-18: COMM Port Communication modes

MODE ¹	ID	DESCRIPTION
QUIET	1	Quiet mode suppresses any feedback from the analyzer (iDAS reports, and warning messages) to the remote device and is typically used when the port is communicating with a computer program such as APICOM. Such feedback is still available but a command must be issued to receive them.
COMPUTER	2	Computer mode inhibits echoing of typed characters and is used when the port is communicating with a computer program, such as APICOM.
SECURITY	4	When enabled, the serial port requires a password before it will respond. The only command that is active is the help screen (? CR).
HESSEN PROTOCOL	16	The Hessen communications protocol is used in some European countries. Teledyne Instruments part number 02252 contains more information on this protocol.
E, 7, 1	2048	When turned on this mode switches the COMM port settings from No parity; 8 data bits; 1 stop bit to Even parity; 7 data bits; 1 stop bit
RS-485	1024	Configures the COM2 Port for RS-485 communication. RS-485 mode has precedence over multidrop mode if both are enabled.
MULTIDROP PROTOCOL	32	Multidrop protocol allows a multi-instrument configuration on a single communications channel. Multidrop requires the use of instrument IDs.
ENABLE MODEM	64	Enables to send a modem initialization string at power-up. Asserts certain lines in the RS-232 port to enable the modem to communicate.
ERROR CHECKING ²	128	Fixes certain types of parity errors at certain Hessen protocol installations.
XON/XOFF HANDSHAKE ²	256	Disables XON/XOFF data flow control also known as software handshaking.
HARDWARE HANDSHAKE	8	Enables CTS/RTS style hardwired transmission handshaking. This style of data transmission handshaking is commonly used with modems or terminal emulation protocols as well as by Teledyne Instrument's APICOM software.
HARDWARE FIFO ²	512	Improves data transfer rate when on of the COMM ports.
COMMAND PROMPT	4096	Enables a command prompt when in terminal mode.
¹ Modes are listed in the order in which they appear in the SETUP → MORE → COMM → COM[1 OR 2] → MODE menu ² The default sting for this feature is ON . Do not disable unless instructed to by Teledyne Instruments Customer Service personnel.		

Press the following keys to select a communication mode for a one of the COMM Ports, such as the following example where **HESSEN PROTOCOL** mode is enabled:

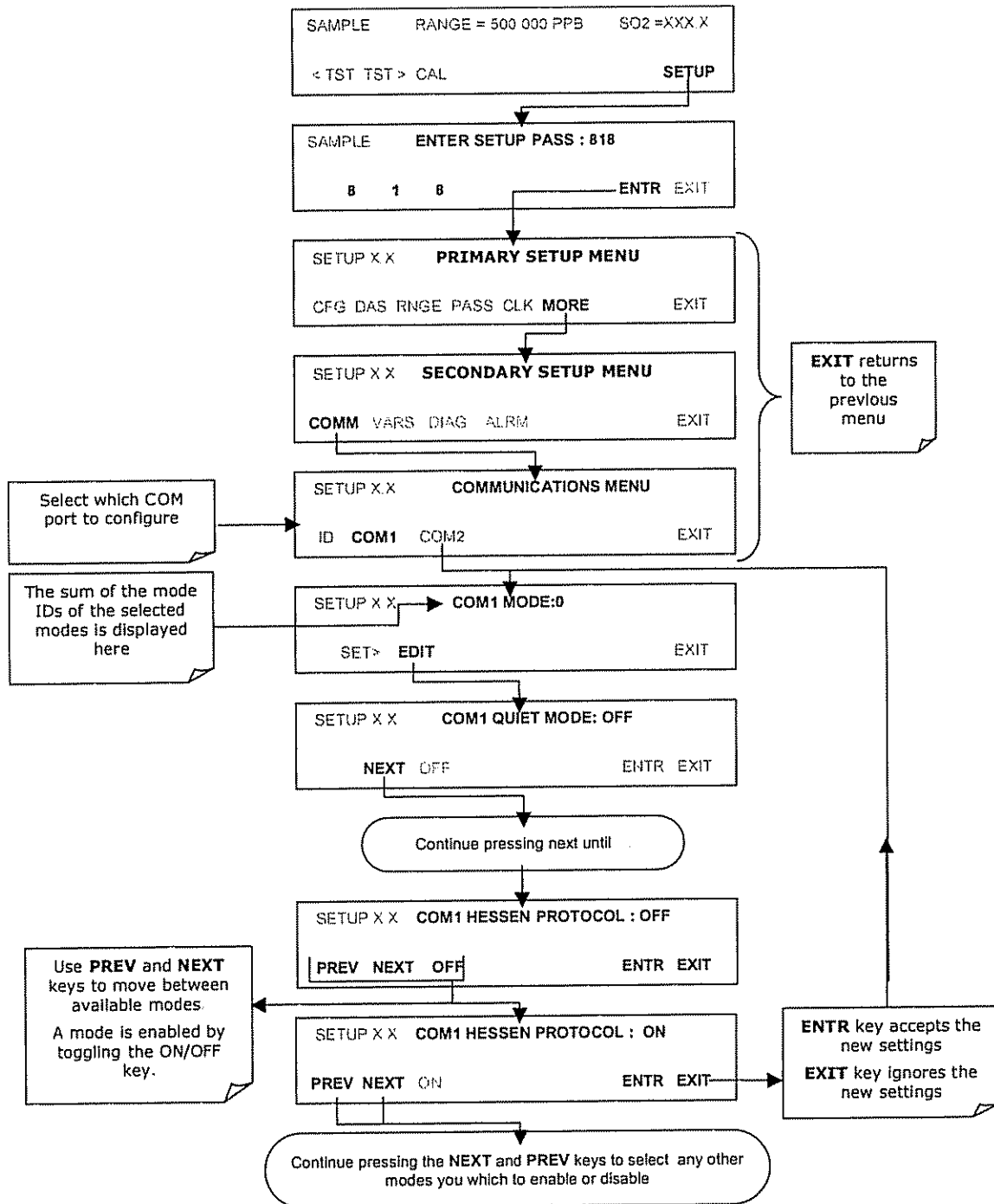

6.10.9. COM PORT BAUD RATE

To select the baud rate of one of the COM Ports, press:

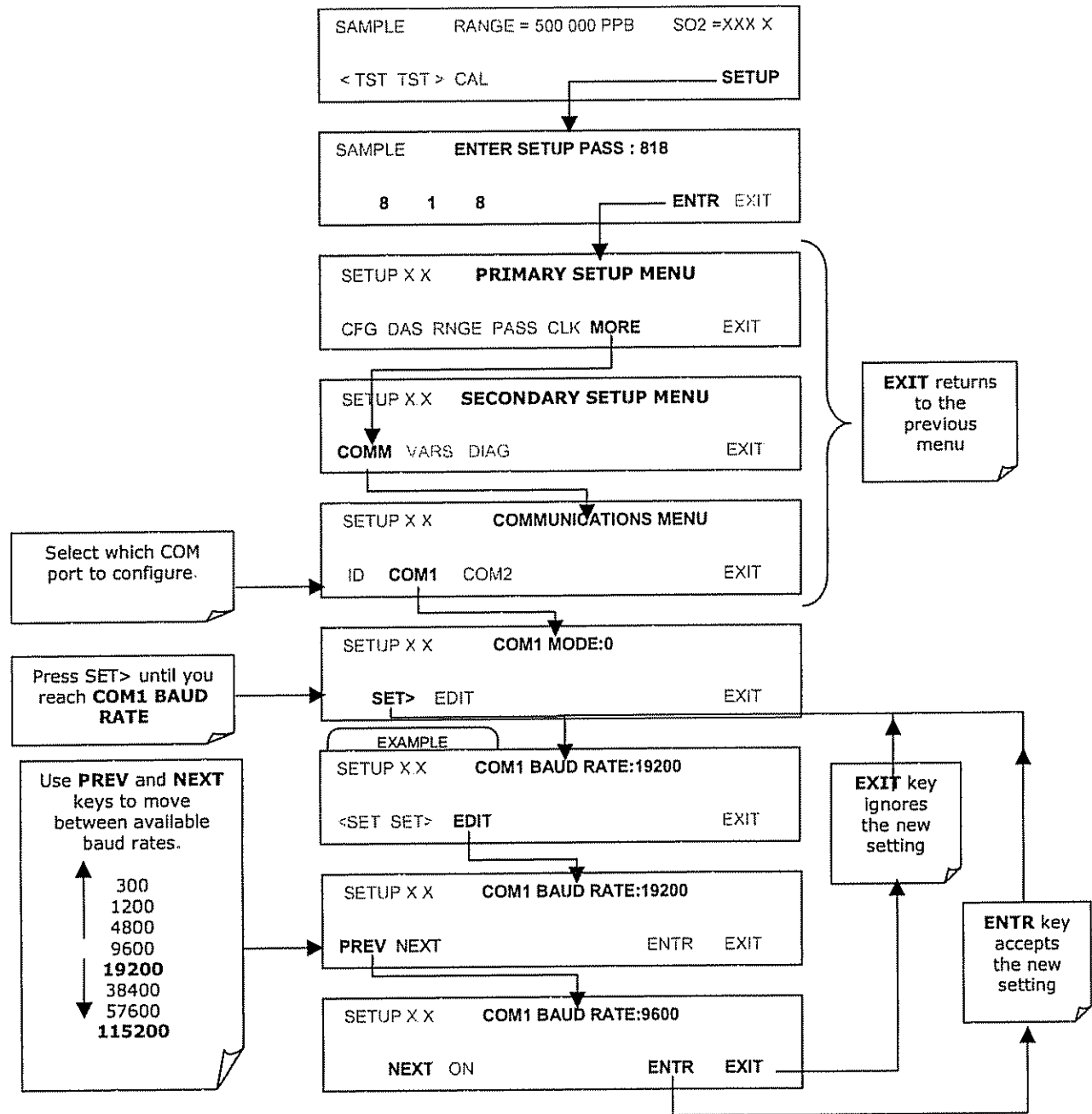

6.10.10. COM PORT TESTING

The serial ports can be tested for correct connection and output in the **COMM** menu. This test sends a string of 256 'w' characters to the selected COM port. While the test is running, the red LED on the rear panel of the analyzer should flicker.

To initiate the test press the following key sequence.

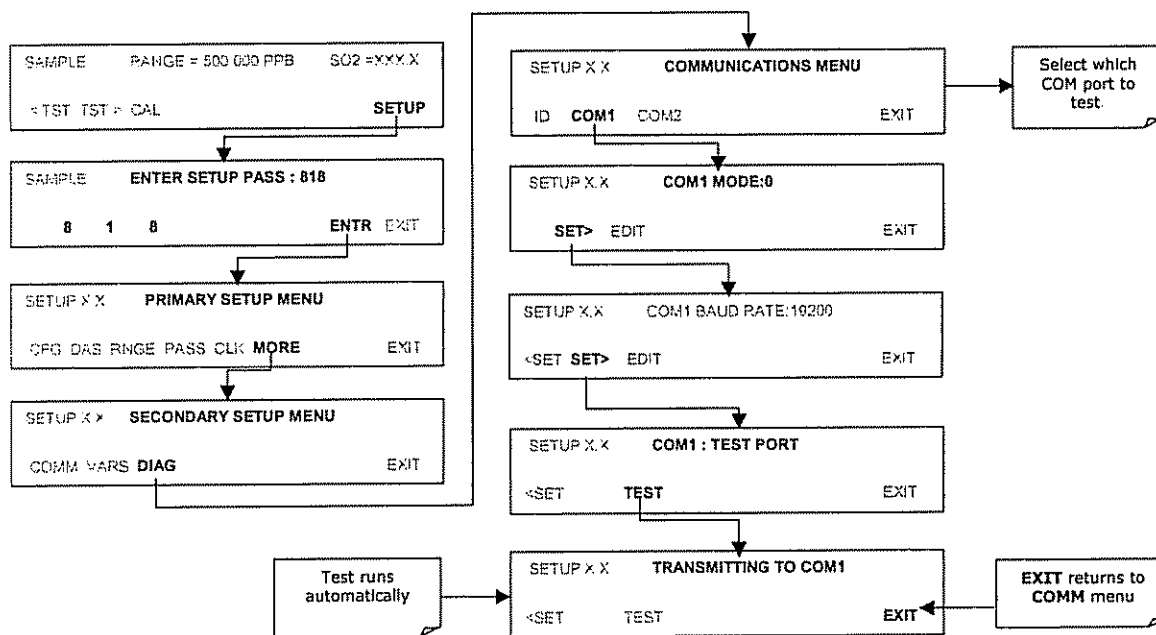

6.11. USING THE DATA ACQUISITION SYSTEM (IDAS)

The 6400E analyzer contains a flexible and powerful, internal data acquisition system (IDAS) that enables the analyzer to store concentration and calibration data as well as a host of diagnostic parameters. The iDAS of the 6400E can store up to about one million data points, which can, depending on individual configurations, cover days, weeks or months of valuable measurements. The data are stored in non-volatile memory and are retained even when the instrument is powered off. Data are stored in plain text format for easy retrieval and use in common data analysis programs (such as spreadsheet-type programs).

The iDAS is designed to be flexible, users have full control over the type, length and reporting time of the data. The iDAS permits users to access stored data through the instrument's front panel or its communication ports. Using APICOM, data can even be retrieved automatically to a remote computer for further processing.

The principal use of the iDAS is logging data for trend analysis and predictive diagnostics, which can assist in identifying possible problems before they affect the functionality of the analyzer. The secondary use is for data analysis, documentation and archival in electronic format.

To support the iDAS functionality, Teledyne Instruments offers APICOM, a program that provides a visual interface for remote or local setup, configuration and data retrieval of the iDAS (see Section 6.11). The APICOM manual, which is included with the program, contains a more detailed description of the iDAS structure and configuration, which is briefly described in this section.

The 6400E is configured with a basic iDAS configuration, which is enabled by default. New data channels are also enabled by default but each channel may be turned off for later or occasional use. Note that iDAS operation is suspended while its configuration is edited through the front panel. To prevent such data loss, it is recommended to use the APICOM graphical user interface for iDAS changes.

The green SAMPLE LED on the instrument front panel, which indicates the analyzer status, also indicates certain aspects of the iDAS status:

Table 6-19: Front Panel LED Status Indicators for iDAS

LED STATE	IDAS STATUS
Off	System is in calibration mode. Data logging can be enabled or disabled for this mode. Calibration data are typically stored at the end of calibration periods, concentration data are typically not sampled, diagnostic data should be collected.
Blinking	Instrument is in hold-off mode, a short period after the system exits calibrations. iDAS channels can be enabled or disabled for this period. Concentration data are typically disabled whereas diagnostic should be collected.
On	Sampling normally.

The iDAS can be disabled only by disabling or deleting its individual data channels.

6.11.1. IDAS STRUCTURE

The iDAS is designed around the feature of a "record". A record is a single data point of one parameter, stored in one (or more) data channels and generated by one of several triggering event. The entire iDAS configuration is stored in a script, which can be edited from the front panel or downloaded, edited and uploaded to the instrument in form of a string of plain-text lines through the communication ports.

iDAS data are defined by the PARAMETER type and are stored through different triggering EVENTS in data CHANNELS, which relate triggering events to data parameters and define certain operational functions related to the recording and reporting of the data.

6.11.1.1. iDAS Channels

The key to the flexibility of the iDAS is its ability to store a large number of combinations of triggering events and data parameters in the form of data channels. Users may create up to 20 data channels and each channel can contain one or more parameters. For each channel one triggering event is selected and up to 50 data parameters, which can be the same or different between channels. Each data channel has several properties that define the structure of the channel and allow the user to make operational decisions regarding the channel (see Table 6-20).

Table 6-20: iDAS Data Channel Properties

PROPERTY	DESCRIPTION	DEFAULT	SETTING RANGE
NAME	The name of the data channel.	"NONE"	Up to 6 letters and digits (more with APICOM, but only the first six are displayed on the front panel).
TRIGGERING EVENT	The event that triggers the data channel to measure and store its data parameters. See APPENDIX A-5 for a list of available triggering events.	ATIMER	Any allowed event.
NUMBER AND LIST OF PARAMETERS	A User-configurable list of data types to be recorded in any given channel. See APPENDIX A-5 for a list of available parameters	1 - PMTDET	Any available concentration, temperature, pneumatic or diagnostic parameter.
REPORT PERIOD	The amount of time between each channel data point.	000:01:00	000:00:01 to 366:23:59 (Days:Hours:Minutes)
NUMBER OF RECORDS	The number of reports that will be stored in the data file. Once the specified limit has been exceeded, the oldest data are overwritten to make space for new data.	100	1 to 1 million, limited by available storage space.
RS-232 REPORT	Enables the analyzer to automatically report channel values to the RS-232 ports.	OFF	OFF or ON
CHANNEL ENABLED	Enables or disables the channel. Provides a convenient means to temporarily disable a data channel.	ON	OFF or ON
CAL HOLD OFF	Disables sampling of data parameters while instrument is in calibration mode. Note that - when enabled here - there is also a length of the DAS HOLD OFF after calibration mode, which is set in the VARS menu (see Section 6.11.2.11.)	OFF	OFF or ON

6.11.1.2. iDAS Parameters

Data parameters are types of data that may be measured and stored by the iDAS. For each Teledyne Instruments analyzer model, the list of available data parameters is different, fully defined and not customizable. Appendix A-5 lists firmware specific data parameters for the 6400E. The most common parameters are concentrations of the measured gas (SO₂), temperatures of heated zones (converter, sample chamber, box temperature...), pressures and flows of the pneumatic subsystem and other diagnostic measurements as well as calibration data (slope and offset) for each gas.

Most data parameters have associated measurement units, such as mV, ppb, cm³/min, etc., although some parameters have no units. The only units that can be changed are those of the concentration readings according to the **SETUP-RANGE** settings. Note that the iDAS does not keep track of the unit of each concentration value and iDAS data files may contain concentrations in multiple units if the unit was changed during data acquisition.

Each data parameter has user-configurable functions that define how the data are recorded (see Table 6-21).

Table 6-21: iDAS Data Parameter Functions

FUNCTION	EFFECT
PARAMETER	Instrument-specific parameter name.
SAMPLE MODE	INST: Records instantaneous reading. AVG: Records average reading during reporting interval. MIN: Records minimum (instantaneous) reading during reporting interval. MAX: Records maximum (instantaneous) reading during reporting interval.
PRECISION	Decimal precision of parameter value(0-4).
STORE NUM. SAMPLES	OFF: stores only the average (default). ON: stores the average and the number of samples in each average for a parameter. This property is only useful when the AVG sample mode is used. Note that the number of samples is the same for all parameters in one channel and needs to be specified only for one of the parameters in that channel.

Users can specify up to 50 parameters per data channel (the 6400E provides about 30 parameters). However, the number of parameters and channels is ultimately limited by available memory.

6.11.1.3. iDAS Triggering Events

Triggering events define when and how the iDAS records a measurement of any given data channel. Triggering events are firmware-specific and are listed in Appendix A-5. The most common triggering events are:

- **ATIMER:** Sampling at regular intervals specified by an automatic timer. Most trending information is usually stored at such regular intervals, which can be instantaneous or averaged.
- **EXITZR, EXITSP, SLPCHG** (exit zero, exit span, slope change): Sampling at the end of (irregularly occurring) calibrations or when the response slope changes. These triggering events create instantaneous data points, e.g., for the new slope and offset (concentration response) values at the end of a calibration. Zero and

slope values are valuable to monitor response drift and to document when the instrument was calibrated.

- **WARNINGS:** Some data may be useful when stored if one of several warning messages appears. This is helpful for trouble-shooting by monitoring when a particular warning occurred.

6.11.2. DEFAULT IDAS CHANNELS

A set of default Data Channels has been included in the analyzer's software for logging SO₂ concentration and certain predictive diagnostic data. These default channels include but are not limited to:

CONC: Samples SO₂ concentration at one minute intervals and stores an average every five minutes with a time and date stamp. Readings during calibration and calibration hold off are not included in the data. By default, the last 4032 hourly averages are stored.

PNUMTC: Collects sample flow and sample pressure data at five minute intervals and stores an average once a day with a time and date stamp. This data is useful for monitoring the condition of the pump and critical flow orifice (sample flow) and the sample filter (clogging indicated by a drop in sample pressure) over time to predict when maintenance will be required. The last 360 daily averages (about 1 year) are stored.

CALDAT: Logs new slope and offset every time a zero or span calibration is performed. This Data Channel also records the instrument reading just prior to performing a calibration. **Note:** this Data Channel collects data based on an event (a calibration) rather than a timer. This Data Channel will store data from the last 200 calibrations. This does not represent any specific length of time since it is dependent on how often calibrations are performed. As with all Data Channels, a time and date stamp is recorded for every data point logged.

DETAIL: Samples fourteen different parameters related to the operating status of the analyzers optical sensors and PMT. For each parameter:

- A value is logged once every minute;
- An average of the last 60 readings is calculated once every.
- The last 480 averages are stored (20 days).

This channel is useful for diagnosing problems that cause the instruments measurements to drift slowly over time

FAST: Almost identical to **DETAIL** except that for each parameter:

- Samples are taken once per minute and reported once per minute, in effect causing the instrument to record an instantaneous reading of each parameter every minute.
- The last 360 readings for each parameter are recorded/reported.

This channel is useful for diagnosing transients; spikes and noise problems.

These default Data Channels can be used as they are, or they can be customized to fit a specific application. They can also be deleted to make room for custom user-programmed Data Channels. This can be done via the instruments front panel or downloaded via the analyzer's COM ports using a program such as APICOM (see Section 6.12.2.8) or other terminal emulation program.

NOTE

Sending an iDAS configuration to the analyzer through its COM ports will replace the existing configuration and will delete all stored data. Back up any existing data and the iDAS configuration before uploading new settings.

The Channel Properties, Triggering Events and Data Parameters/Functions for these default channels are:

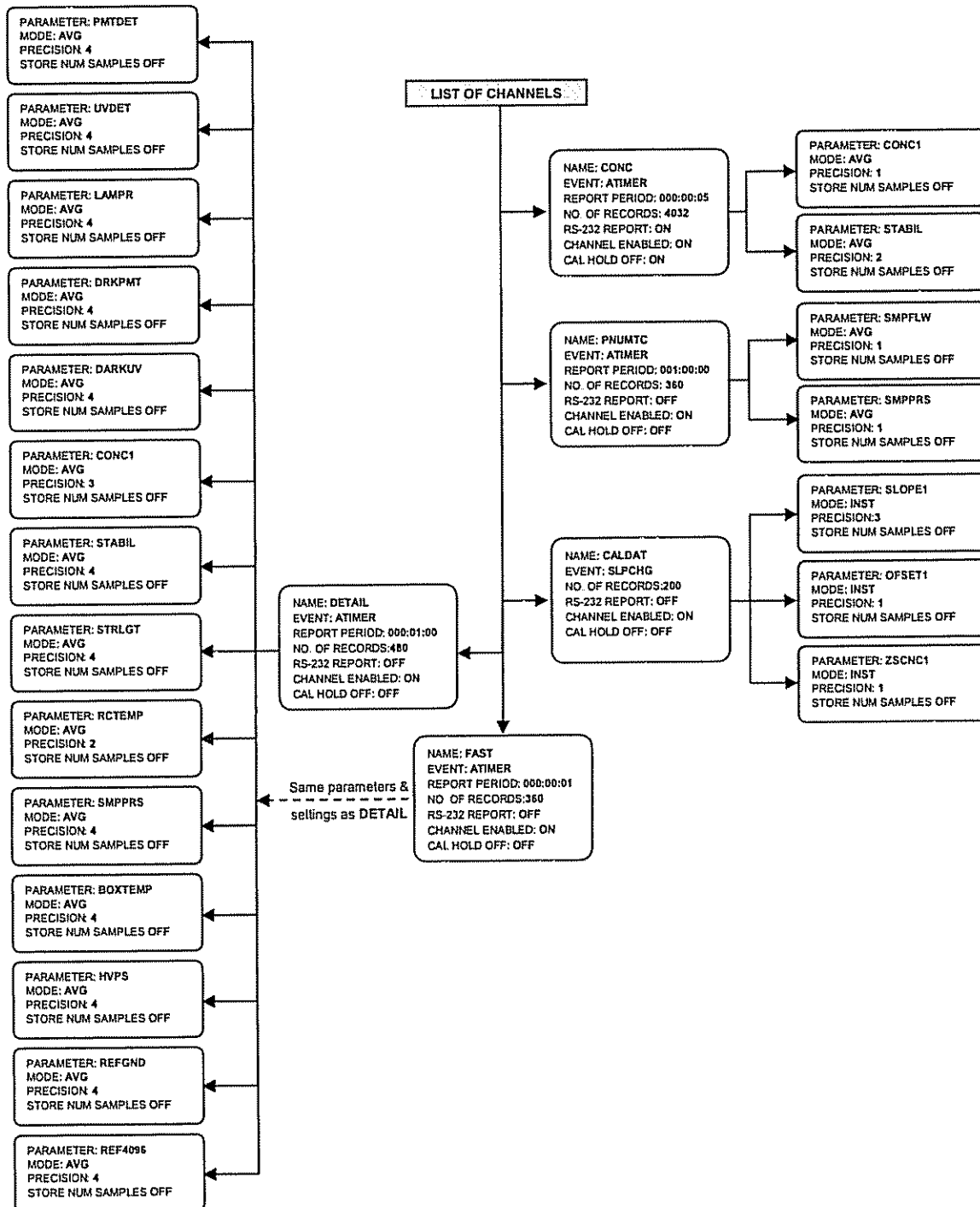
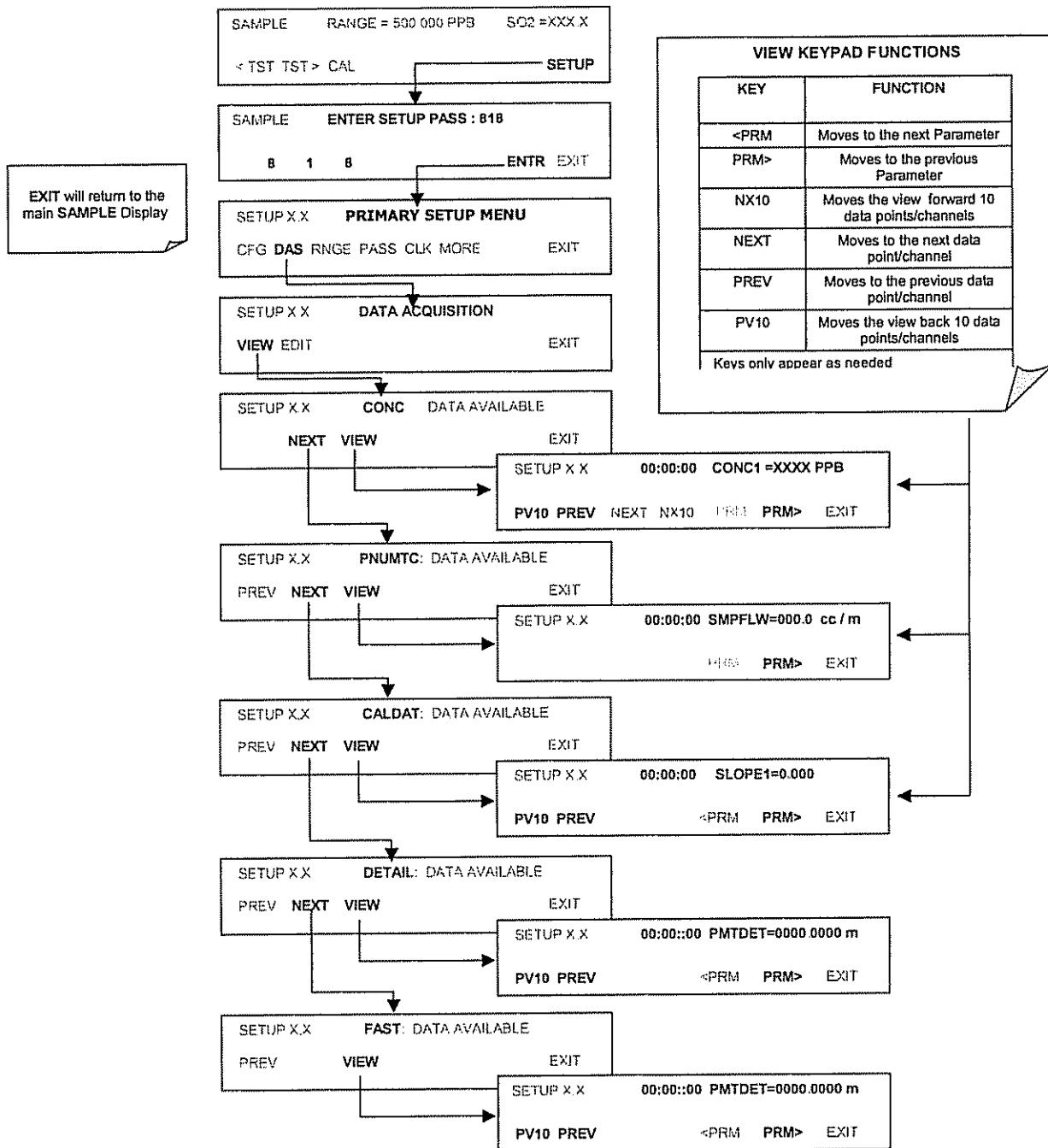

Figure 6-14: Default iDAS Channels Setup

6.11.2.1. Viewing iDAS Data and Settings

iDAS data and settings can be viewed on the front panel through the following keystroke sequence.



6.11.2.2. Editing iDAS Data Channels

Although IDAS configuration is most conveniently done through the APICOM remote control program (see Section 6.12.2.8), the following list of key strokes shows how to edit iDAS channels using the analyzer's front panel.

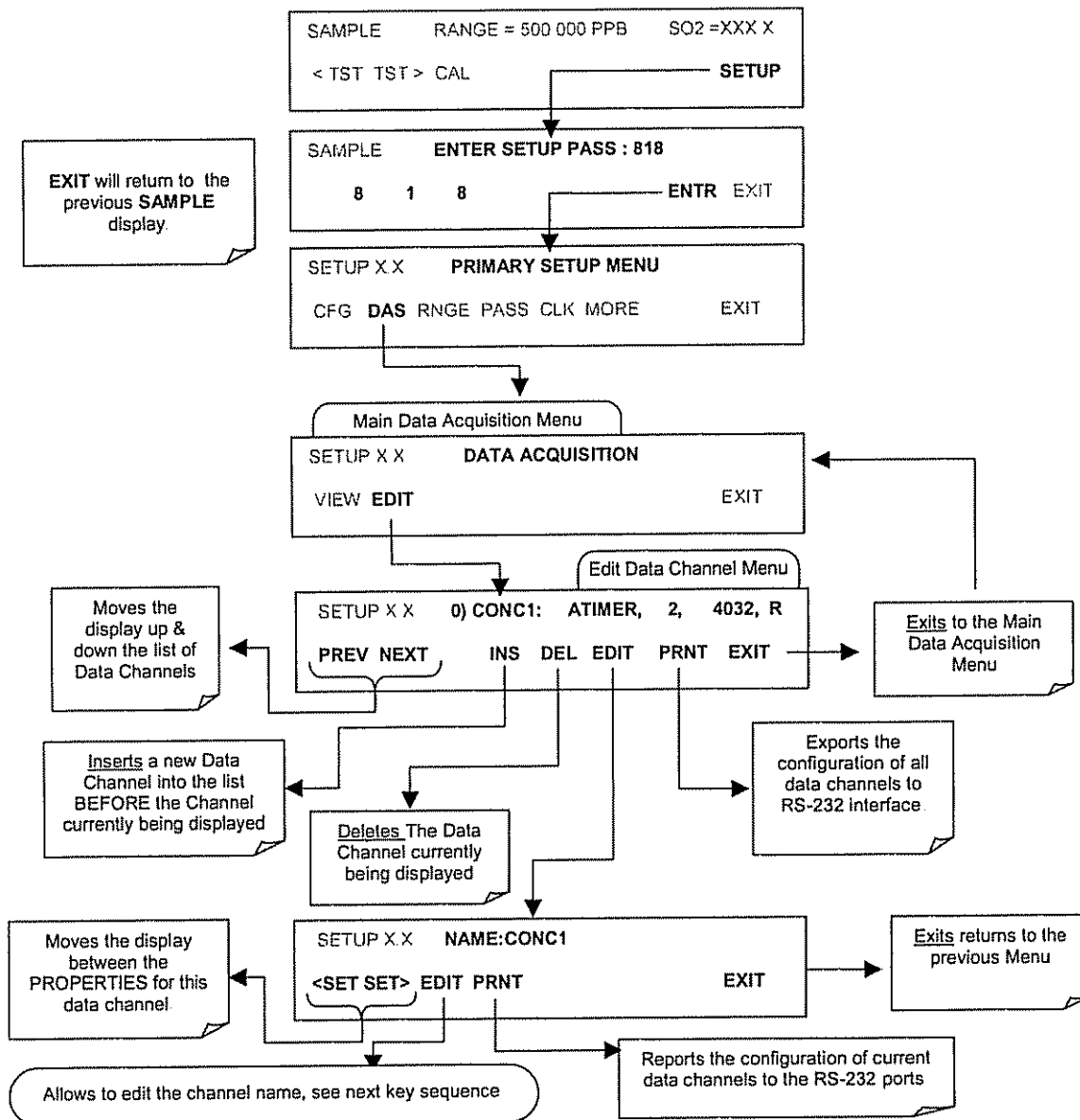

When editing the data channels, the top line of the display indicates some of the configuration parameters. For example, the display line:

0) CONC : ATIMER, 4, 800

represents to the following configuration:

- Channel No.: 0
- NAME: CONC
- TRIGGER EVENT: ATIMER
- PARAMETERS: Four parameters are included in this channel
- EVENT: This channel is set up to record 800 data points.

To edit the name of a data channel, follow the above key sequence and then press:

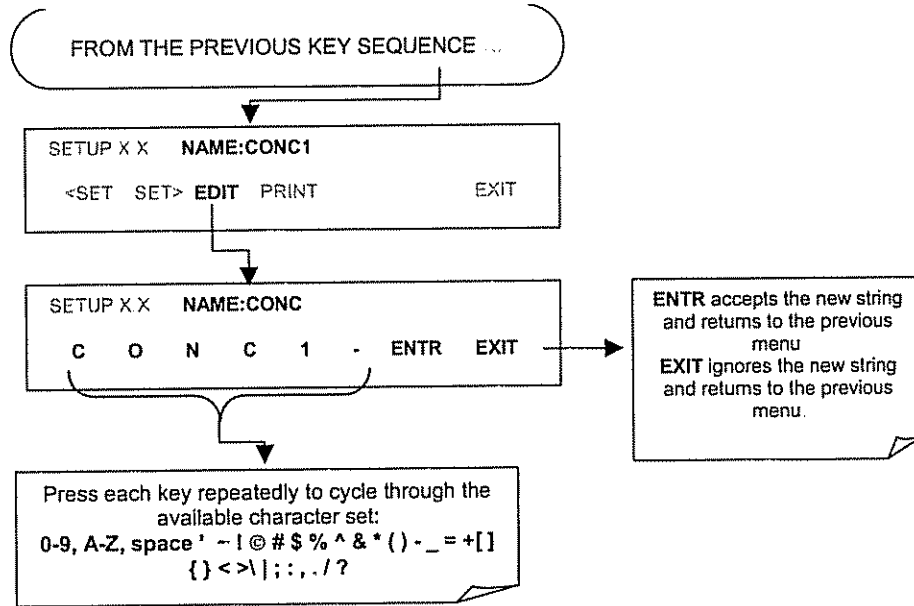

6.11.2.3. Trigger Events

To edit the list of data parameters associated with a specific data channel, press:

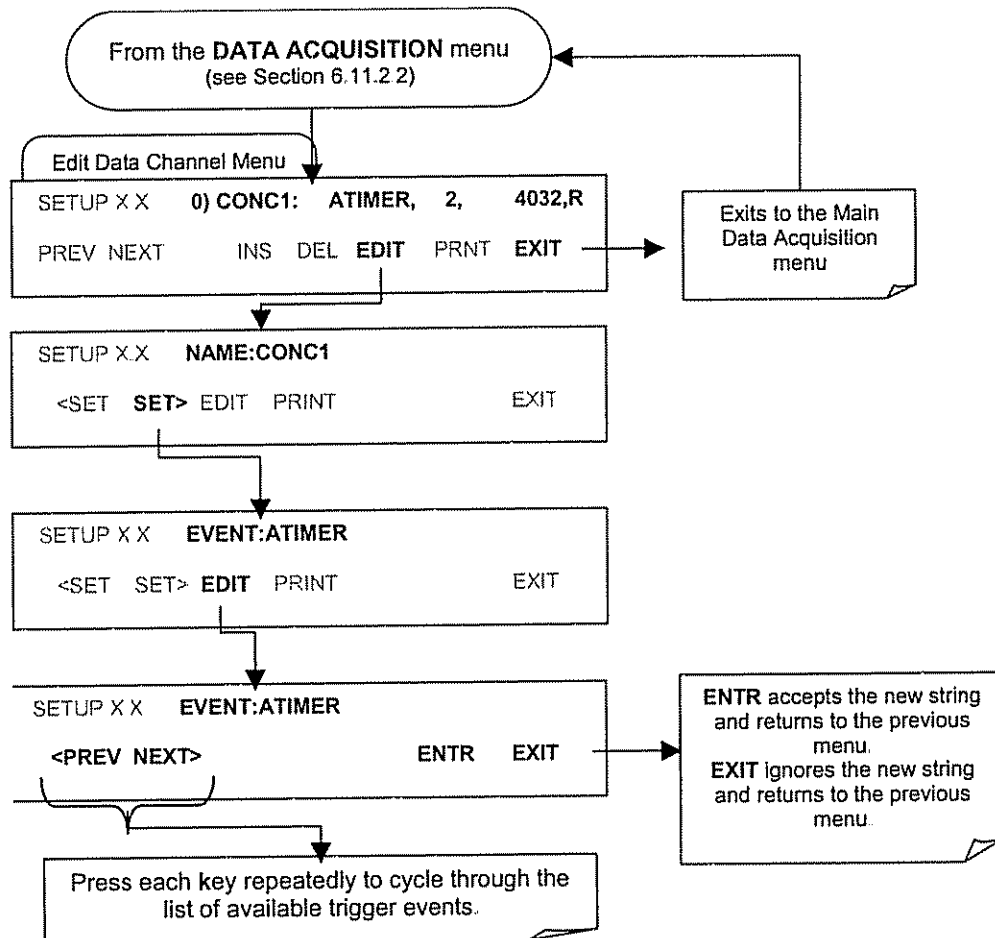

6.11.2.4. Editing iDAS Parameters

Data channels can be edited individually from the front panel without affecting other data channels. However, when editing a data channel, such as during adding, deleting or editing parameters, all data for that particular channel will be lost, because the iDAS can store only data of one format (number of parameter columns etc.) for any given channel. In addition, an iDAS configuration can only be uploaded remotely as an entire set of channels. Hence, remote update of the iDAS will always delete all current channels and stored data.

To modify, add or delete a parameter, follow the instruction shown in section 6.11.2.2 then press:

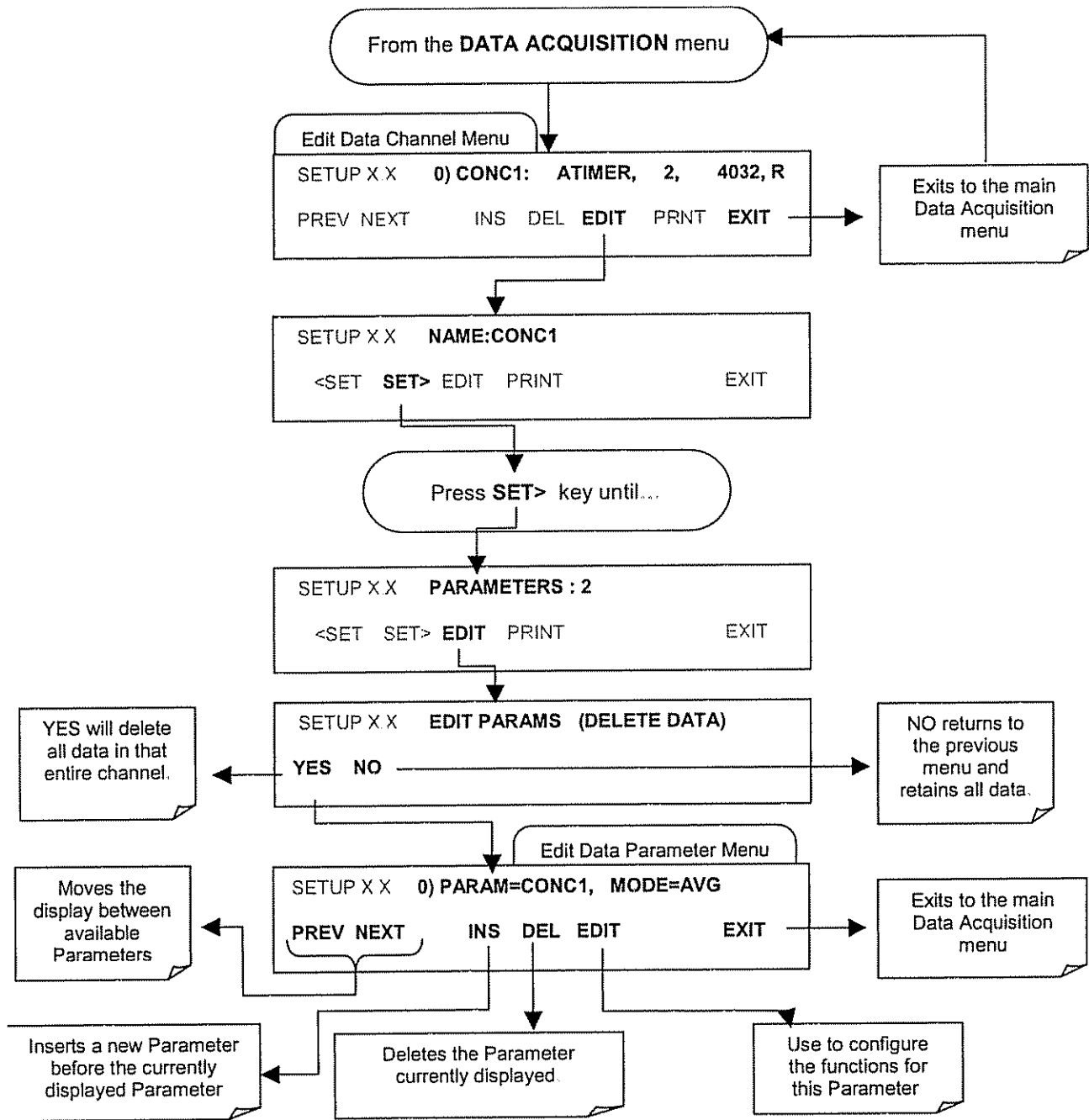

To configure the parameters for a specific data parameter, press:

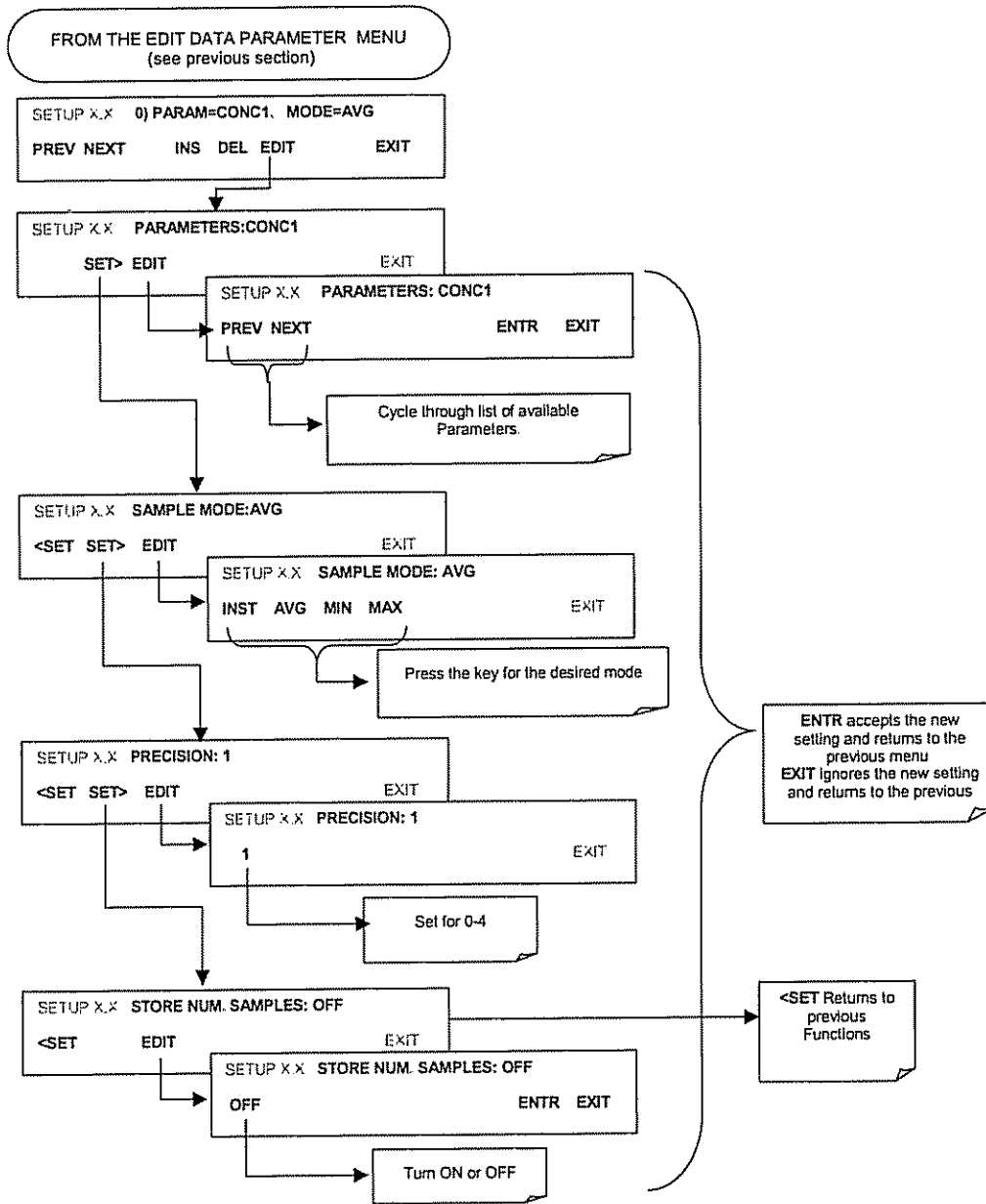

6.11.2.5. Sample Period and Report Period

The iDAS defines two principal time periods by which sample readings are taken and permanently recorded:

- SAMPLE PERIOD:** Determines how often iDAS temporarily records a sample reading of the parameter in volatile memory. The **SAMPLE PERIOD** is set to one minute by default and generally cannot be accessed from the standard iDAS front panel menu, but is available via the instruments communication ports by using APICOM or the analyzer's standard serial data protocol.

SAMPLE PERIOD is only used when the iDAS parameter's sample mode is set for **AVG**, **MIN** or **MAX**.

- **REPORT PERIOD:** Sets how often the sample readings stored in volatile memory are processed, (e.g. average, minimum or maximum are calculated) and the results stored permanently in the instruments Disk-on-Chip as well as transmitted via the analyzer's communication ports. The **REPORT PERIOD** may be set from the front panel.

If the **INST** sample mode is selected the instrument stores and reports an instantaneous reading of the selected parameter at the end of the chosen **REPORT PERIOD**

In **AVG, MIN** or **MAX** sample modes, the settings for the **SAMPLE PERIOD** and the **REPORT PERIOD** determine the number of data points used each time the average, minimum or maximum is calculated, stored and reported to the COMM ports. The actual sample readings are not stored past the end of the of the chosen **REPORT PERIOD**.

Also, the **SAMPLE PERIOD** and **REPORT PERIOD** intervals are synchronized to the beginning and end of the appropriate interval of the instruments internal clock.

- If **SAMPLE PERIOD** were set for one minute the first reading would occur at the beginning of the next full minute according to the instrument's internal clock.
- If the **REPORT PERIOD** were set for of one hour the first report activity would occur at the beginning of the next full hour according to the instrument's internal clock.

EXAMPLE: Given the above settings, if iDAS were activated at 7:57:35 the first sample would occur at 7:58 and the first report would be calculated at 8:00 consisting of data points for 7:58, 7:59 and 8:00.

During the next hour (from 8:01 to 9:00) the instrument will take a sample reading every minute and include 60 sample readings.

When the **STORE NUM. SAMPLES** feature is turned on the instrument will also store how many sample readings were used for the **AVG, MIN** or **MAX** calculation but not the readings themselves.

REPORT PERIODS IN PROGRESS WHEN INSTRUMENT IS POWERED OFF

If the instrument is powered off in the middle of a **REPORT PERIOD**, the samples accumulated so far during that period are lost. Once the instrument is turned back on, the iDAS restarts taking samples and temporarily them in volatile memory as part of the **REPORT PERIOD** currently active at the time of restart. At the end of this **REPORT PERIOD** only the sample readings taken since the instrument was turned back on will be included in any **AVG, MIN** or **MAX** calculation. Also, the **STORE NUM. SAMPLES** feature will report the number of sample readings taken since the instrument was restarted.

To define the **REPORT PERIOD**, follow the instruction shown in section 6.11.2.2 then press:

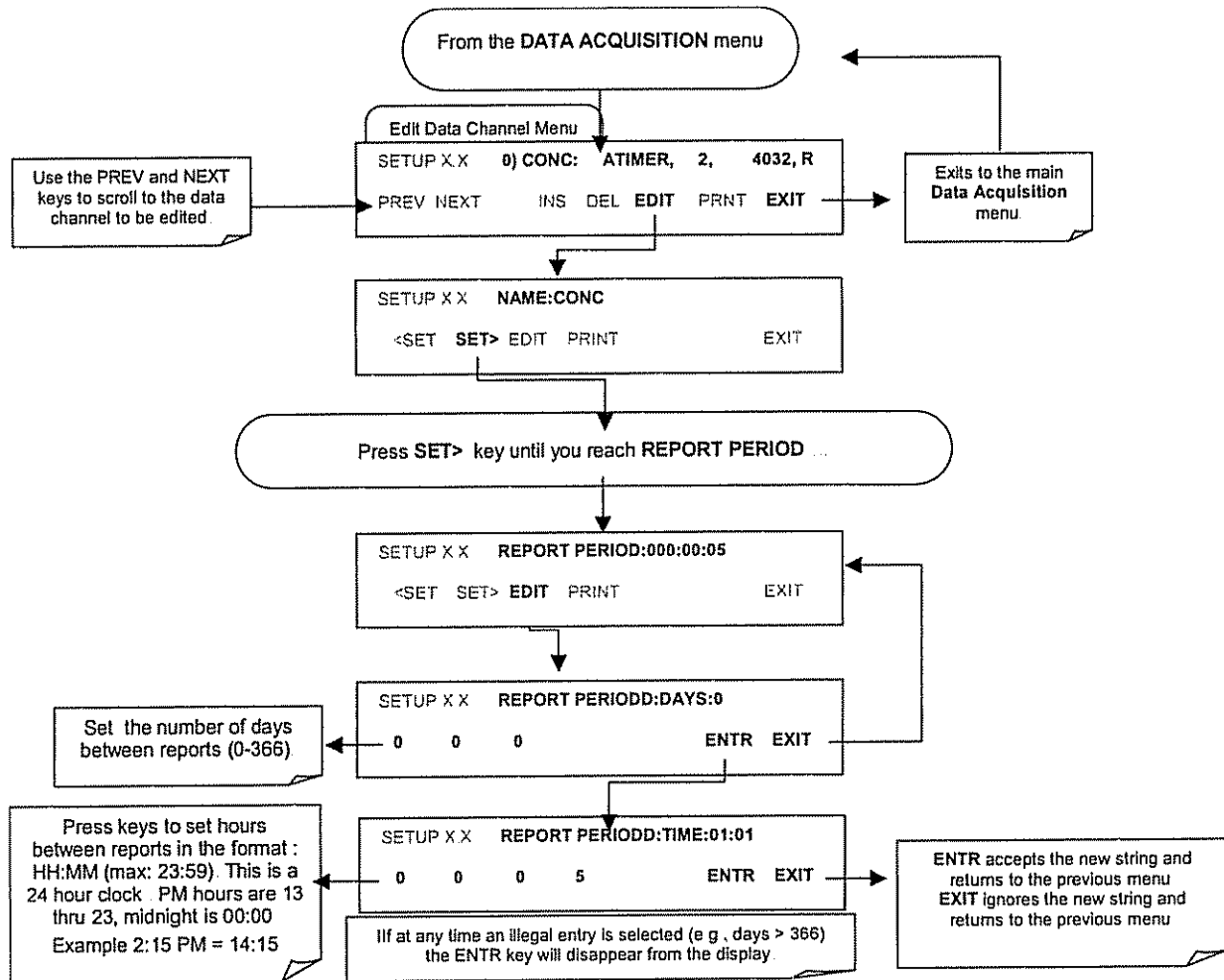

6.11.2.6. Number of Records

The number of data records in the 6400E is limited to about a cumulative one million data points in all channels (one megabyte of space on the disk-on-chip). However, the actual number of records is also limited by the total number of parameters and channels and other settings in the IDAS configuration. Every additional data channel, parameter, number of samples setting etc. will reduce the maximum amount of data points somewhat. In general, however, the maximum data capacity is divided amongst all channels (max: 20) and parameters (max: 50 per channel).

The IDAS will check the amount of available data space and prevent the user from specifying too many records at any given point. If, for example, the IDAS memory space can accommodate 375 more data records, the ENTR key will disappear when trying to specify more than that number of records. This check for memory space may also make an upload of an IDAS configuration with APICOM or a Terminal program fail, if the combined number of records would be exceeded. In this case, it is suggested to either try from the front panel what the maximum number of records can be or use trial-and-error in designing the IDAS script or calculate the number of records using the DAS or APICOM manuals. To set the number of records for one channel from the front panel, press SETUP-DAS-EDIT-ENTR and the following key sequence.

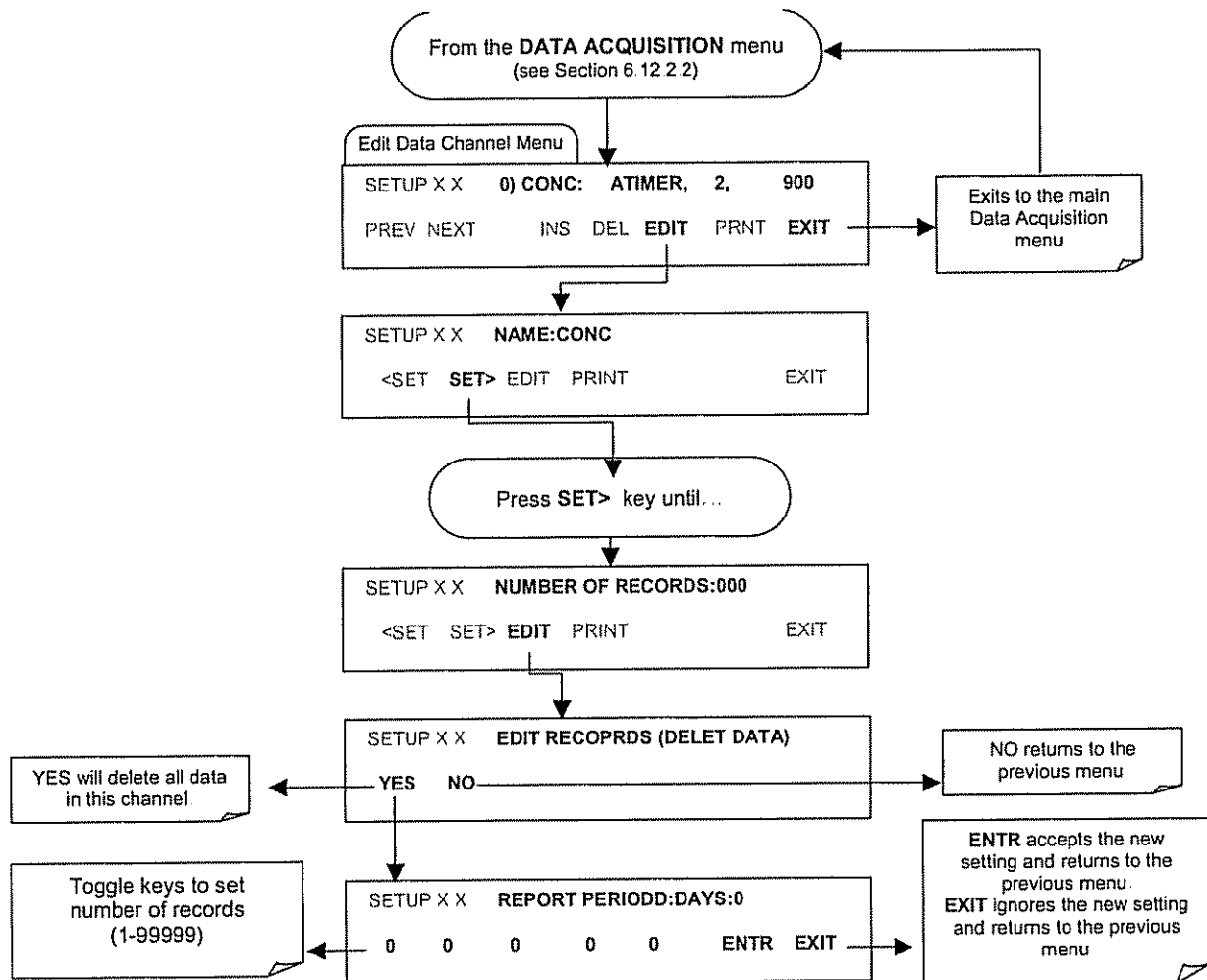

6.11.2.7. RS-232 Report Function

The 6400E iDAS can automatically report data to the communications ports, where they can be captured with a terminal emulation program or simply viewed by the user.

To enable automatic COM port reporting, follow the instruction shown in section 6.11.2.2 then press:

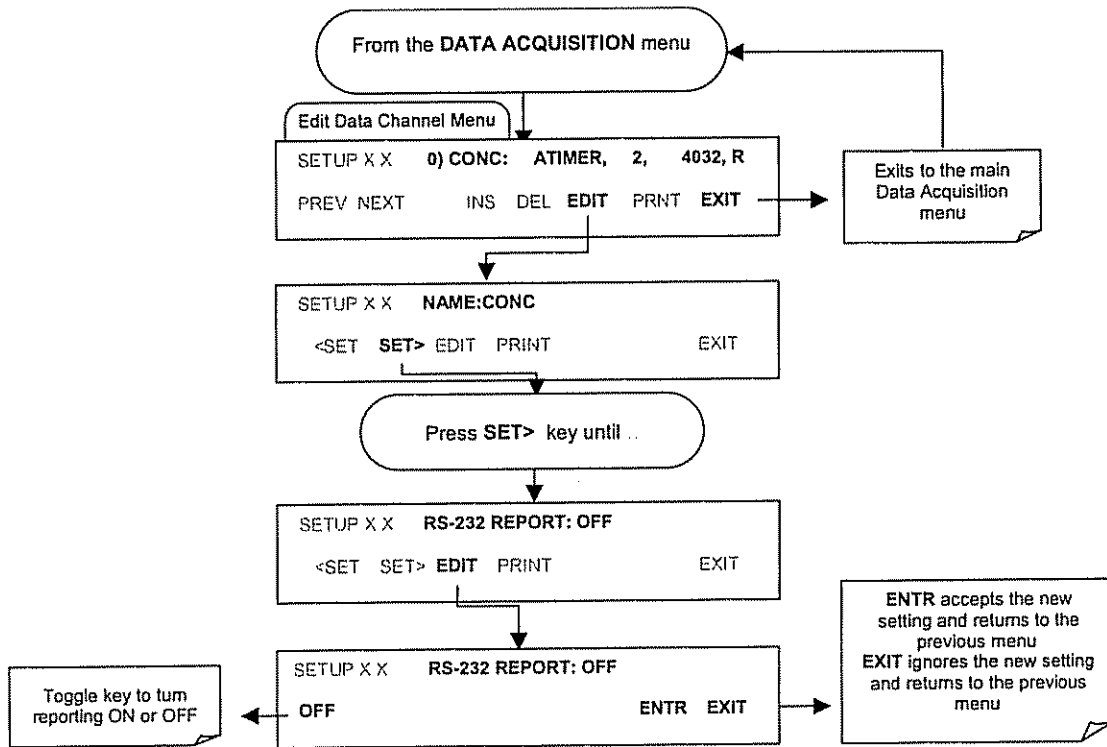

6.11.2.8. Compact Report

When enabled, this option avoids unnecessary line breaks on all RS-232 reports. Instead of reporting each parameter in one channel on a separate line, up to five parameters are reported in one line, instead.

6.11.2.9. Starting Date

This option allows to specify a starting date for any given channel in case the user wants to start data acquisition only after a certain time and date. If the **Starting Date** is in the past, the iDAS ignores this setting.

6.11.2.10. Disabling/Enabling Data Channels

Data channels can be temporarily disabled, which can reduce the read/write wear on the disk-on-chip. The ALL_01 channel of the 6400E, for example, is disabled by default.

To disable a data channel, follow the instruction shown in section 6.11.2.2 then press:

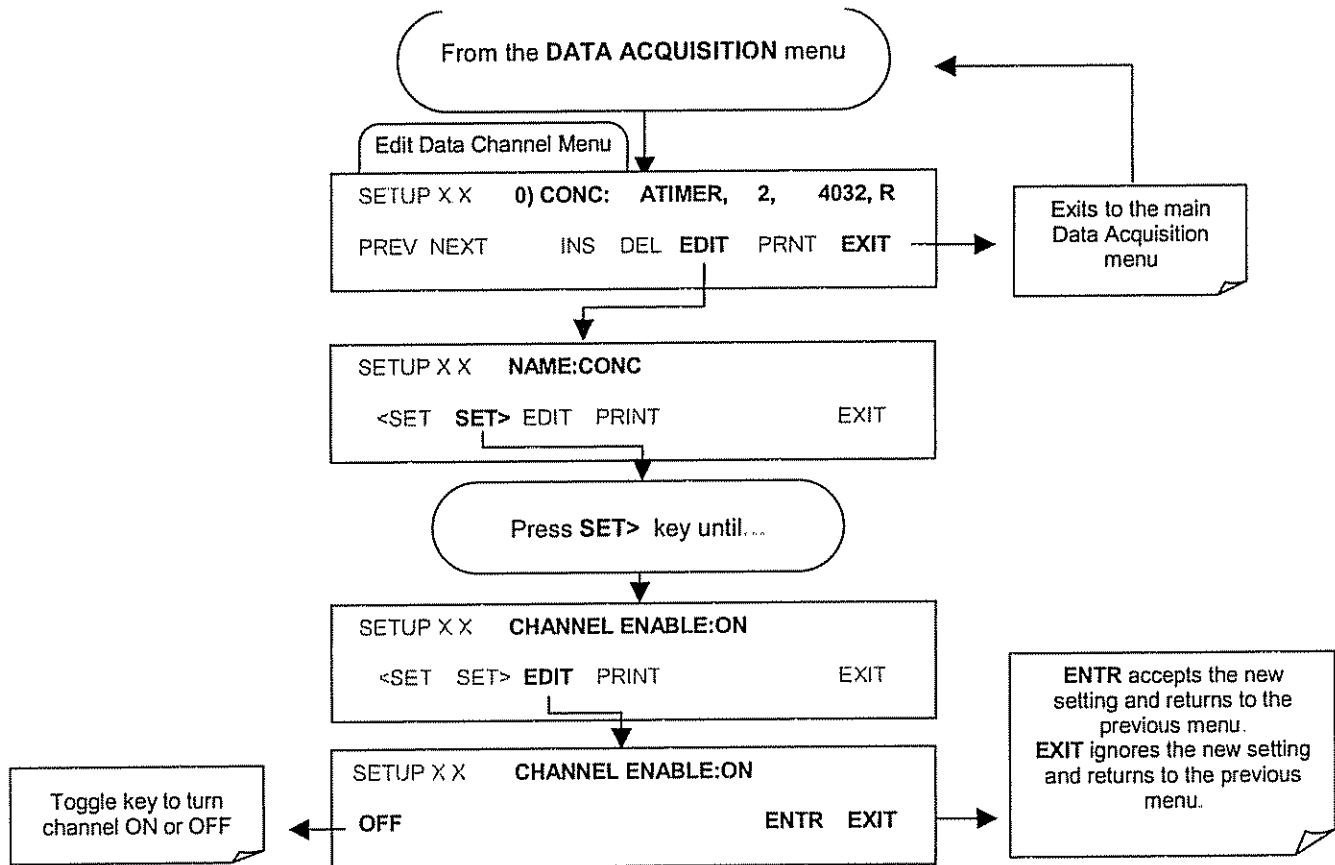

6.11.2.11. HOLDOFF Feature

The iDAS HOLDOFF feature allows to prevent data collection during calibrations and during the DAS_HOLD OFF period enabled and specified in the VARS (see Section 6.8). To enable or disable the HOLDOFF, follow the instruction shown in Section 6.11.2.2 then press:

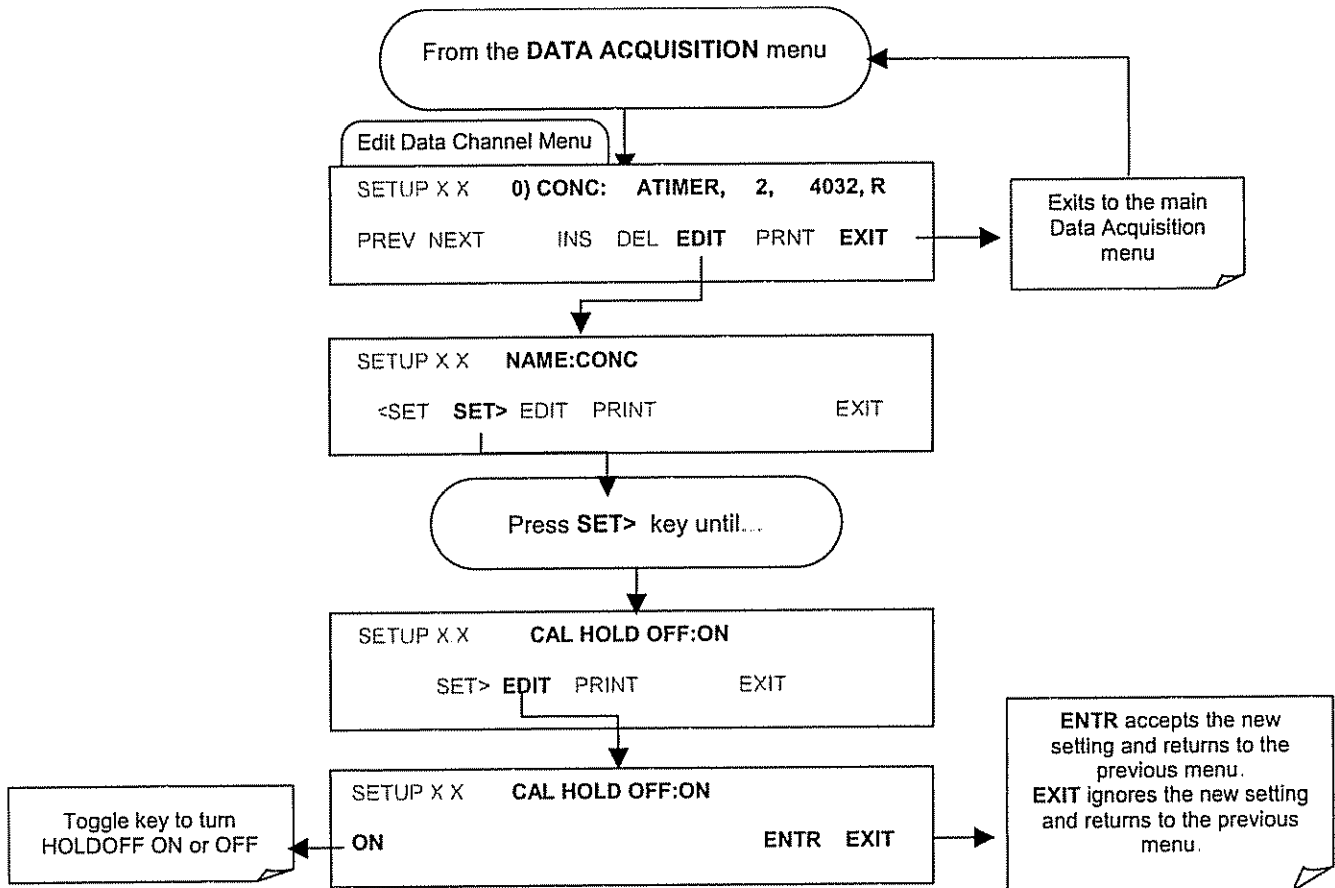

6.11.3. REMOTE IDAS CONFIGURATION

Editing channels, parameters and triggering events as described in this section is can be performed via the APICOM remote control program using the graphic interface similar to the example shown in Figure 6-15. Refer to the Section 6.12 for details on remote access to the 6400E analyzer. *Note: M100E is equivalent to M6400E.*

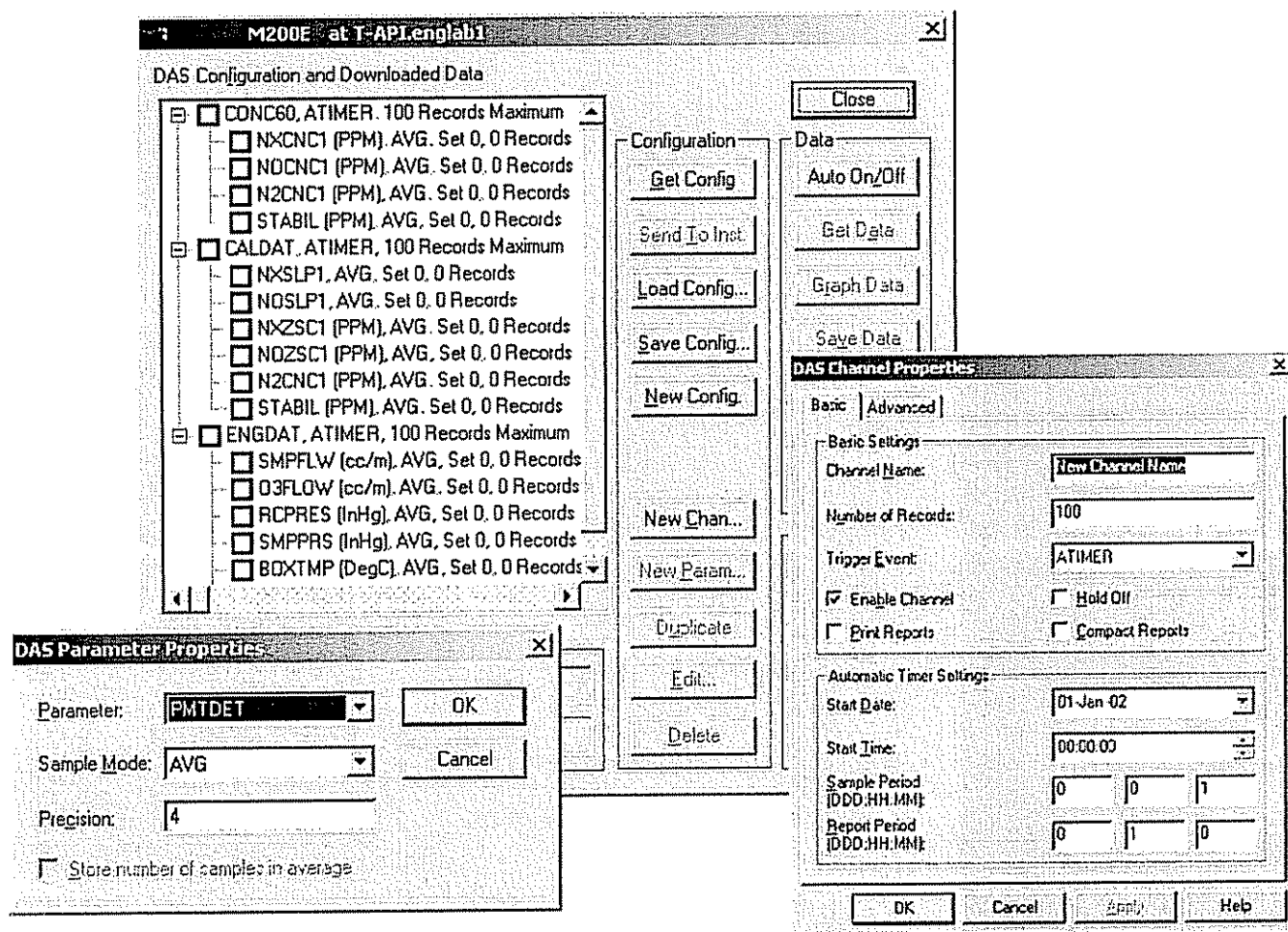

Figure 6-15: Sample APICOM user interface for configuring the iDAS.

Once an iDAS configuration is edited (which can be done offline and without interrupting DAS data collection), it is conveniently uploaded to the instrument and can be stored on a computer for later review, alteration or documentation and archival. Refer to the APICOM manual for details on these procedures. The APICOM user manual (Teledyne Instruments part number 039450000) is included in the APICOM installation file, which can be downloaded at <http://www.teledyne-api.com/software/apicom/>.

Although Teledyne Analytical Instruments recommends the use of APICOM, the iDAS can also be accessed and configured through a terminal emulation program such as HyperTerminal (see Figure 6-16). However, all configuration commands must be created following a strict syntax or be pasted in from of a text file, which was edited offline and then uploaded through a specific transfer procedure.

```

M200E at CAS - HyperTerminal
File Edit View Call Transfer Help
[Icons]
SETUP PROPERTIES FOR ENGDAT:
NAME: ENGDAT
EVENT: ATIMER
REPORT PERIOD: 000:00:02
NUMBER OF RECORDS: 2000
RS-232 REPORT: ON
CHANNEL ENABLED: ON
CAL. HOLD OFF: OFF
PARAMETERS: 14
PARAMETER=RCTEMP, MODE=AVG, PRECISION=4, STORE_SAMPLES=OFF
PARAMETER=CNVTMP, MODE=AVG, PRECISION=4, STORE_SAMPLES=OFF
PARAMETER=PMTTMP, MODE=AVG, PRECISION=4, STORE_SAMPLES=OFF
PARAMETER=BOXTMP, MODE=AVG, PRECISION=4, STORE_SAMPLES=OFF
PARAMETER=O3FLOW, MODE=AVG, PRECISION=4, STORE_SAMPLES=OFF
PARAMETER=SMFPLW, MODE=AVG, PRECISION=4, STORE_SAMPLES=OFF
PARAMETER=SMPPRS, MODE=AVG, PRECISION=4, STORE_SAMPLES=OFF
PARAMETER=RCPRES, MODE=AVG, PRECISION=4, STORE_SAMPLES=OFF
PARAMETER=AZERO, MODE=AVG, PRECISION=4, STORE_SAMPLES=OFF
PARAMETER=HVPS, MODE=AVG, PRECISION=4, STORE_SAMPLES=OFF
PARAMETER=PMTDET, MODE=AVG, PRECISION=4, STORE_SAMPLES=OFF
PARAMETER=RF4096, MODE=AVG, PRECISION=4, STORE_SAMPLES=OFF
PARAMETER=REFGND, MODE=AVG, PRECISION=4, STORE_SAMPLES=OFF
Connected 00:01:32 Auto detect TCP/IP SCROLL CAPS NUM Capture Print echo

```

Figure 6-16: iDAS Configuration Through a Terminal Emulation Program.

Both procedures are best started by downloading the default iDAS configuration, getting familiar with its command structure and syntax conventions, and then altering a copy of the original file offline before uploading the new configuration.

CAUTION

Whereas the editing, adding and deleting of iDAS channels and parameters of one channel through the front-panel keyboard can be done without affecting the other channels, uploading an iDAS configuration script to the analyzer through its communication ports will erase all data, parameters and channels by replacing them with the new iDAS configuration. Backup of data and the original iDAS configuration is advised before attempting any iDAS changes.

6.12. REMOTE OPERATION OF THE ANALYZER

6.12.1. REMOTE OPERATION USING THE EXTERNAL DIGITAL I/O

6.12.1.1. Status Outputs

The status outputs report analyzer conditions via optically isolated NPN transistors, which sink up to 50 mA of DC current. These outputs can be used interface with devices that accept logic-level digital inputs, such as programmable logic controllers (PLC's). Each Status bit is an open collector output that can withstand up to 40 VDC. All of the emitters of these transistors are tied together and available at D.

NOTE

Most PLC's have internal provisions for limiting the current that the input will draw from an external device. When connecting to a unit that does not have this feature, an external dropping resistor must be used to limit the current through the transistor output to less than 50 mA. At 50 mA, the transistor will drop approximately 1.2V from its collector to emitter.

The status outputs are accessed through a 12 pin connector on the analyzer's rear panel labeled STATUS (see Figure 6-17). The function of each pin is defined in Table 6-22.

STATUS

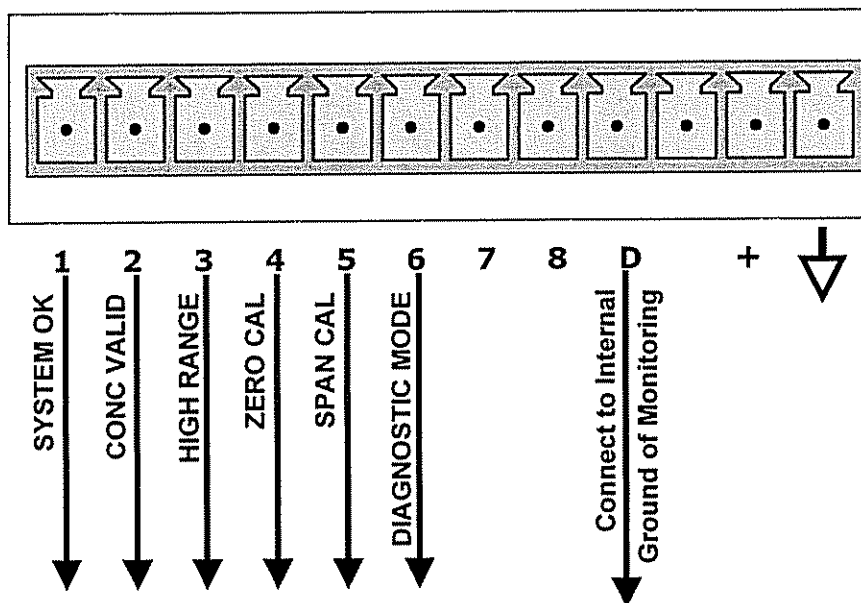



Figure 6-17: Status Output Connector

Table 6-22: Status Output Pin Assignments

CONNECTOR PIN	STATUS	CONDITION (ON=CONDUCTING)
1	System Ok	ON if no faults are present.
2	Conc Valid	ON if concentration measurement is valid, OFF when invalid.
3	High Range	ON if unit is in high range of any AUTO range mode.
4	Zero Cal	ON whenever the instrument is in ZERO calibration mode.
5	Span Cal	ON whenever the instrument is in SPAN calibration mode.
6	Diag Mode	ON whenever the instrument is in DIAGNOSTIC mode.
7-8		Unused
D	Emitter Bus	The emitters of the transistors on pins 1-8 are bussed together. For most applications, this pin should be connected to the circuit ground of the receiving device.
+	Dc Power	+ 5 VDC source, 30 mA maximum (combined rating with Control Inputs)
	Digital Ground	The ground from the analyzer's internal, 5/±15 VDC power supply.

6.12.1.2. Control Inputs

Control inputs allow the user to remotely initiate ZERO and SPAN calibration modes are provided through a 10-pin connector labeled CONTROL IN on the analyzer's rear panel. These are opto-isolated, digital inputs that are activated when a 5 VDC signal from the "U" pin is connected to the respective input pin.

Table 6-23: Control Input Pin Assignments

INPUT	STATUS	CONDITION WHEN ENABLED
A	External Zero Cal	Zero calibration mode is activated. The mode field of the display will read ZERO CAL R.
B	External Span Cal	Span calibration mode is activated. The mode field of the display will read SPAN CAL R.
C		Unused
D		Unused
E		Unused
F		Unused
	Digital Ground	Provided to ground an external device (e.g., recorder).
U	DC Power For Input Pull Ups	Input for +5 VDC required to activate inputs A - F. This voltage can be taken from an external source or from the "+" pin.
+	Internal +5v Supply	Internal source of +5V which can be used to activate inputs when connected to pin U.

There are two methods to activate control inputs. The internal +5V available from the "+" pin is the most convenient method (see Figure 6.18). However, to ensure that these inputs are truly isolated, a separate, external 5 VDC power supply should be used (see Figure 6.19).

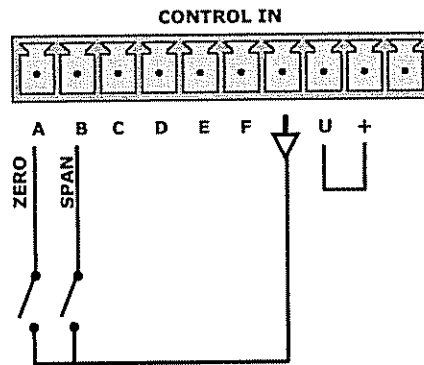

Figure 6-18: Control Inputs with local 5 V power supply

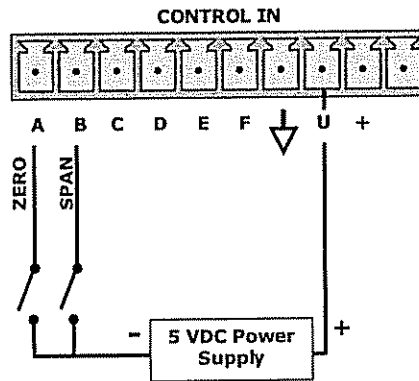

Figure 6-19: Control Inputs with external 5 V power supply

6.12.2. REMOTE OPERATION USING THE EXTERNAL SERIAL I/O

6.12.2.1. Terminal Operating Modes

The Model 6400E can be remotely configured, calibrated or queried for stored data through the serial ports. As terminals and computers use different communication schemes, the analyzer supports two communicate modes specifically designed to interface with these two types of devices.

- **Computer mode** is used when the analyzer is connected to a computer with a dedicated interface program such as APICOM. More information regarding APICOM can be found in later in this section or on the Teledyne Instruments website at <http://www.teledyne-api.com/software/apicom/>.
- **Interactive mode** is used with a terminal emulation programs such as HyperTerminal or a "dumb" computer terminal. The commands that are used to operate the analyzer in this mode are listed in Table 6-24 and in Appendix A-6.

6.12.2.2. Help Commands in Terminal Mode

Table 6-24: Terminal Mode Software Commands

COMMAND	FUNCTION
Control-T	Switches the analyzer to terminal mode (echo, edit). If mode flags 1 & 2 are OFF, the interface can be used in interactive mode with a terminal emulation program.
Control-C	Switches the analyzer to computer mode (no echo, no edit).
CR (carriage return)	A carriage return is required after each command line is typed into the terminal/computer. The command will not be sent to the analyzer to be executed until this is done. On personal computers, this is achieved by pressing the ENTER key.
BS (backspace)	Erases one character to the left of the cursor location.
ESC (escape)	Erases the entire command line.
? [ID] CR	This command prints a complete list of available commands along with the definitions of their functionality to the display device of the terminal or computer being used. The ID number of the analyzer is only necessary if multiple analyzers are on the same communications line, such as the multi-drop setup.
Control-C	Pauses the listing of commands.
Control-P	Restarts the listing of commands.

6.12.2.3. Command Syntax

Commands are not case-sensitive and all arguments within one command (i.e. ID numbers, keywords, data values, etc.) must be separated with a space character.

All Commands follow the syntax:

X [ID] COMMAND <CR>

Where

- X is the command type (one letter) that defines the type of command. Allowed designators are listed in Table 6-25 and Appendix A-6.
- [ID] is the analyzer identification number (see Section 6.10.1.). Example: the Command "? 200" followed by a carriage return would print the list of available commands for the revision of software currently installed in the instrument assigned ID Number 200.
- COMMAND is the command designator: This string is the name of the command being issued (LIST, ABORT, NAME, EXIT, etc.). Some commands may have additional arguments that define how the command is to be executed. Press ? <CR> or refer to Appendix A-6 for a list of available command designators.
- <CR> is a carriage return. All commands must be terminated by a carriage return (usually achieved by pressing the ENTER key on a computer).

Table 6-25: Command Types

COMMAND	COMMAND TYPE
C	Calibration
D	Diagnostic
L	Logon
T	Test measurement
V	Variable
W	Warning

6.12.2.4. Data Types

Data types consist of integers, hexadecimal integers, floating-point numbers, Boolean expressions and text strings.

- Integer data are used to indicate integral quantities such as a number of records, a filter length, etc. They consist of an optional plus or minus sign, followed by one or more digits. For example, +1, -12, 123 are all valid integers.
- Hexadecimal integer data are used for the same purposes as integers. They consist of the two characters "0x," followed by one or more hexadecimal digits (0-9, A-F, a-f), which is the 'C' programming language convention. No plus or minus sign is permitted. For example, 0x1, 0x12, 0x1234abcd are all valid hexadecimal integers.

- Floating-point numbers are used to specify continuously variable values such as temperature set points, time intervals, warning limits, voltages, etc. They consist of an optional plus or minus sign, followed by zero or more digits, an optional decimal point, and zero or more digits. (At least one digit must appear before or after the decimal point.) Scientific notation is not permitted. For example, *+1.0*, *1234.5678*, *-0.1*, *1* are all valid floating-point numbers.
- Boolean expressions are used to specify the value of variables or I/O signals that may assume only two values. They are denoted by the keywords *ON* and *OFF*.
- Text strings are used to represent data that cannot be easily represented by other data types, such as data channel names, which may contain letters and numbers. They consist of a quotation mark, followed by one or more printable characters, including spaces, letters, numbers, and symbols, and a final quotation mark. For example, *"a"*, *"1"*, *"123abc"*, and *"()[]<>"* are all valid text strings. It is not possible to include a quotation mark character within a text string.
- Some commands allow you to access variables, messages, and other items, such as iDAS data channels, by name. When using these commands, you must type the entire name of the item; you cannot abbreviate any names.

6.12.2.5. Status Reporting

Reporting of status messages as an audit trail is one of the three principal uses for the RS-232 interface (the other two being the command line interface for controlling the instrument and the download of data in electronic format). You can effectively disable the reporting feature by setting the interface to quiet mode (see Section 6.10.8., Table 6-18).

Status reports include iDAS data (when reporting is enabled), warning messages, calibration and diagnostic status messages. Refer to Appendix A-3 for a list of the possible messages, and this section for information on controlling the instrument through the RS-232 interface.

General Message Format

All messages from the instrument (including those in response to a command line request) are in the format:

X DDD:HH:MM [Id] MESSAGE<CRLF>

Where

- | | |
|-----------|--|
| X | is a command type designator, a single character indicating the message type, as shown in the Table 6-25. |
| DDD:HH:MM | is the time stamp, the date and time when the message was issued. It consists of the Day-of-year (DDD) as a number from 1 to 366, the hour of the day (HH) as a number from 00 to 23, and the minute (MM) as a number from 00 to 59. |
| [ID] | is the analyzer ID, a number with 1 to 4 digits. |
| MESSAGE | is the message content that may contain warning messages, test measurements, iDAS reports, variable values, etc. |
| <CRLF> | is a carriage return / line feed pair, which terminates the message. |

The uniform nature of the output messages makes it easy for a host computer to parse them into an easy structure. Keep in mind that the front panel display does not give any information on the time a message was issued, hence it is useful to log such messages for trouble-shooting and reference purposes. Terminal emulation programs such as HyperTerminal can capture these messages to text files for later review.

6.12.2.6. Remote Access by Modem

The 6400E can be connected to a modem for remote access. This requires a cable between the analyzer's COM port and the modem, typically a DB-9F to DB-25M cable (available from Teledyne Instruments with part number WR0000024).

Once the cable has been connected, check to make sure the DTE-DCE is in the correct position. Also make sure the 6400E COM port is set for a baud rate that is compatible with the modem, which needs to operate with an 8-bit word length with one stop bit.

The first step is to turn on the **MODEM ENABLE** communication mode (Mode 64, Section 6.10.8). Once this is completed, the appropriate setup command line for your modem can be entered into the analyzer. The default setting for this feature is

```
AT Y0 &D0 &H0 &IO S0=2 &B0 &N6 &M0 E0 Q1 &W0
```

This string can be altered to match your modem's initialization and can be up to 100 characters long.

To change this setting press:

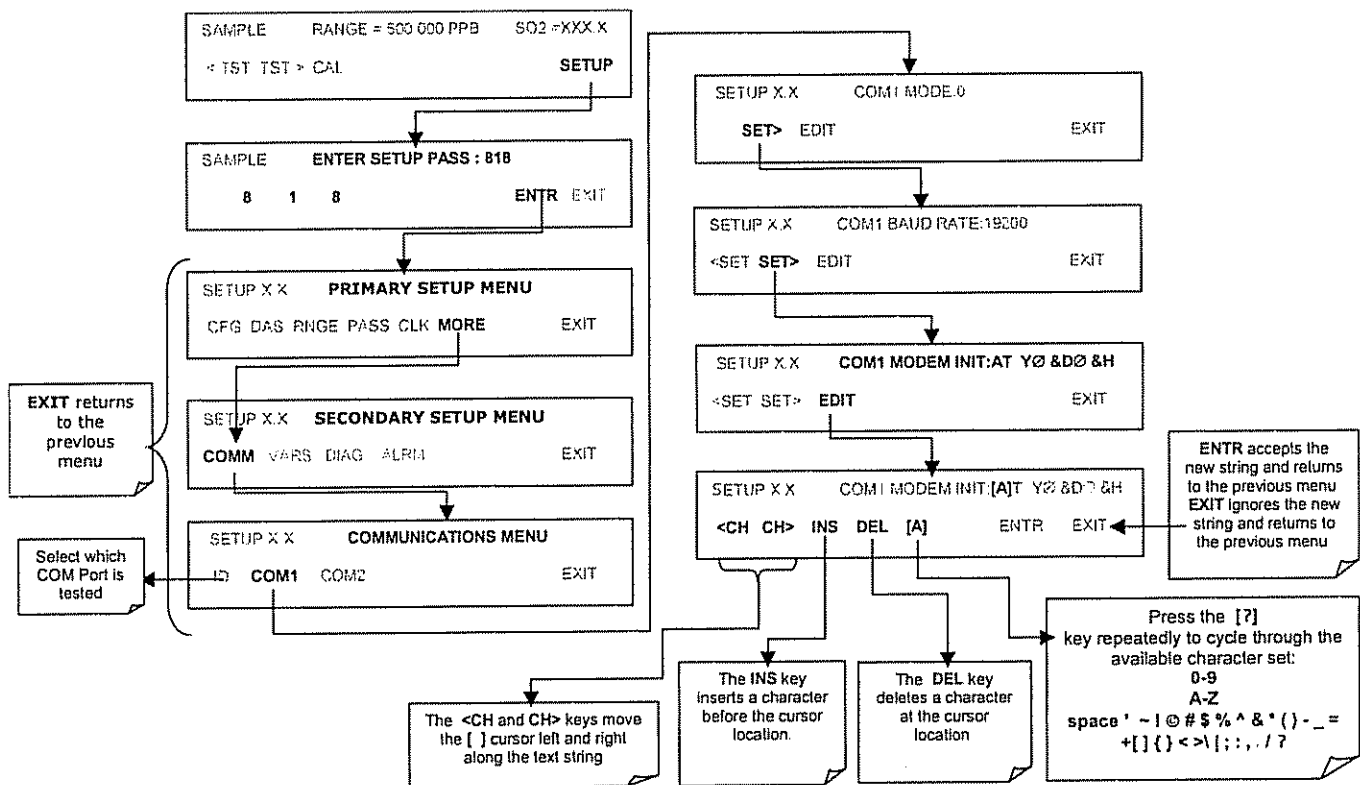

To Initialize the modem press:

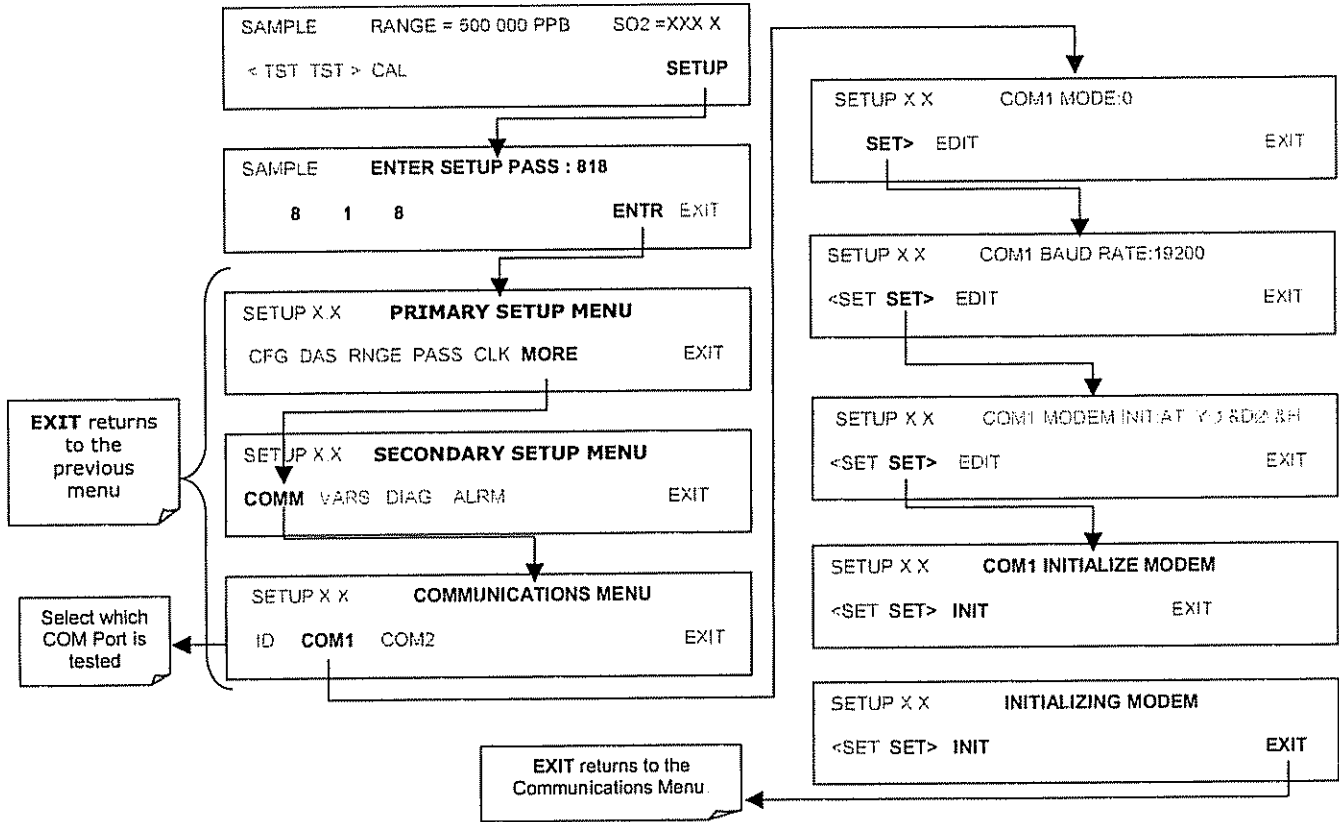

6.12.2.7. COM Port Password Security

In order to provide security for remote access of the 6400E, a LOGON feature can be enabled to require a password before the instrument will accept commands. This is done by turning on the **SECURITY MODE** (see Section 6.10.8). Once the **SECURITY MODE** is enabled, the following items apply.

- A password is required before the port will respond or pass on commands.
- If the port is inactive for one hour, it will automatically logoff, which can also be achieved with the LOGOFF command.
- Three unsuccessful attempts to log on with an incorrect password will cause subsequent logins to be disabled for 1 hour, even if the correct password is used.
- If not logged on, the only active command is the '?' request for the help screen.
- The following messages will be returned at logon:
 - LOGON SUCCESSFUL - Correct password given
 - LOGON FAILED - Password not given or incorrect
 - LOGOFF SUCCESSFUL - Connection terminated successfully

To log on to the 6400E analyzer with **SECURITY MODE** feature enabled, type:

```
LOGON 940331
```

940331 is the default password. To change the default password, use the variable RS232_PASS issued as follows:

```
V RS232_PASS=NNNNNN
```

Where N is any numeral between 0 and 9.

6.12.2.8. APICOM Remote Control Program

APICOM is an easy-to-use, yet powerful interface program that allows to access and control any of Teledyne Instruments' main line of ambient and stack-gas instruments from a remote connection through direct cable, modem or Ethernet. Running APICOM, a user can:

Establish a link from a remote location to the 6400E through direct cable connection via RS-232 modem or Ethernet.

View the instrument's front panel and remotely access all functions that could be accessed when standing in front of the instrument.

Remotely edit system parameters and set points.

Download, view, graph and save data for predictive diagnostics or data analysis.

Retrieve, view, edit, save and upload iDAS configurations.

Check on system parameters for trouble-shooting and quality control.

APICOM is very helpful for initial setup, data analysis, maintenance and trouble-shooting. Figure 6-16 shows an example of APICOM being used to remotely configuration the iDAS feature. Figure 6-20 shows examples of APICOM's main interface, which emulates the look and functionality of the instruments actual front panel

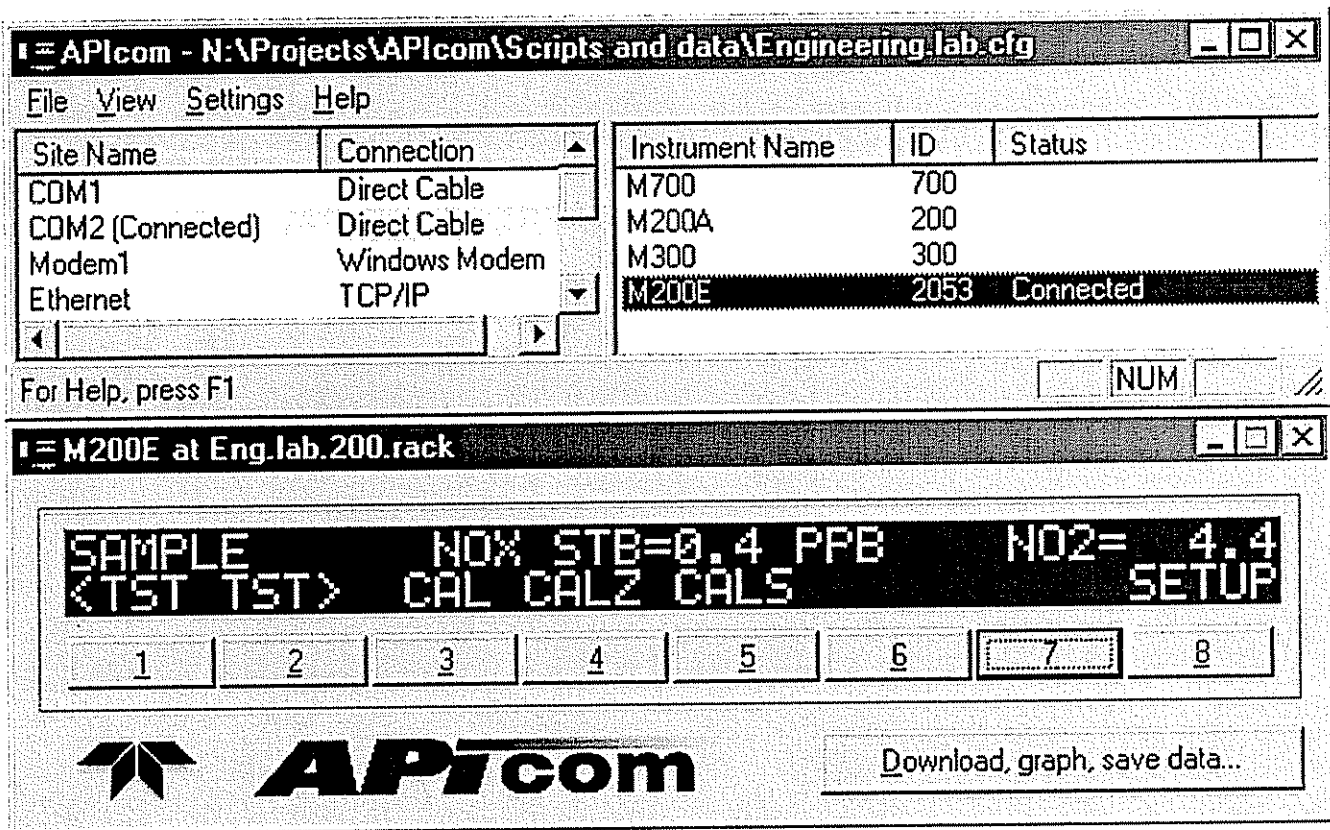

Figure 6-20: APICOM Remote Control Program Interface

APICOM is included free of cost with the analyzer and the latest versions can also be downloaded for free at <http://www.teledyne-api.com/software/apicom/>.

6.12.3. ADDITIONAL COMMUNICATIONS DOCUMENTATION

Table 6-26: Serial Interface Documents

Interface / Tool	Document Title	Part Number	Available Online*
APICOM	APICOM User Manual	039450000	YES
Multi-drop	RS-232 Multi-drop Documentation	021790000	YES
DAS Manual	Detailed description of the iDAS.	028370000	YES

6.12.4. USING THE 6400E WITH A HESSEN PROTOCOL NETWORK

6.12.4.1. General Overview of Hessen Protocol

The Hessen protocol is a multidrop protocol, in which several remote instruments are connected via a common communications channel to a host computer. The remote instruments are regarded as slaves of the host computer. The remote instruments are unaware that they are connected to a multidrop bus and never initiate Hessen protocol messages. They only respond to commands from the host computer and only when they receive a command containing their own unique ID number.

The Hessen protocol is designed to accomplish two things: to obtain the status of remote instruments, including the concentrations of all the gases measured; and to place remote instruments into zero or span calibration or measure mode. Teledyne Analytical Instruments implementation supports both of these principal features.

The Hessen protocol is not well defined, therefore while TAI's application is completely compatible with the protocol itself, it may be different from implementations by other companies.

The following subsections describe the basics for setting up your instrument to operate over a Hessen Protocol network. For more detailed information as well as a list of host computer commands and examples of command and response message syntax, download the *Manual Addendum for Hessen Protocol* from the Teledyne Instruments' web site: <http://www.teledyne-api.com/manuals/index.asp> .

6.12.4.2. Hessen COMM Port Configuration

Hessen protocol requires the communication parameters of the 6400E's COMM ports to be set differently than the standard configuration as shown in the table below.

Table 6-27: RS-232 Communication Parameters for Hessen Protocol

Parameter	Standard	Hessen
Data Bits	8	7
Stop Bits	1	2
Parity	None	Even
Duplex	Full	Half

To change the rest of the COMM port parameters and modes (see Section 6.10.8).

To change the baud rate of the 6400E's COMM ports (see Section 6.10.9.)

NOTE

Make sure that the communication parameters of the host computer are also properly set.

Also, the instrument software has a 200 ms. latency before it responds to commands issued by the host computer. This latency should present no problems, but you should be aware of it and not issue commands to the instrument too frequently.

6.12.4.3. Activating Hessen Protocol

The first step in configuring the 6400E to operate over a Hessen protocol network is to activate the Hessen mode for COMM ports and configure the communication parameters for the port(s) appropriately. Press:

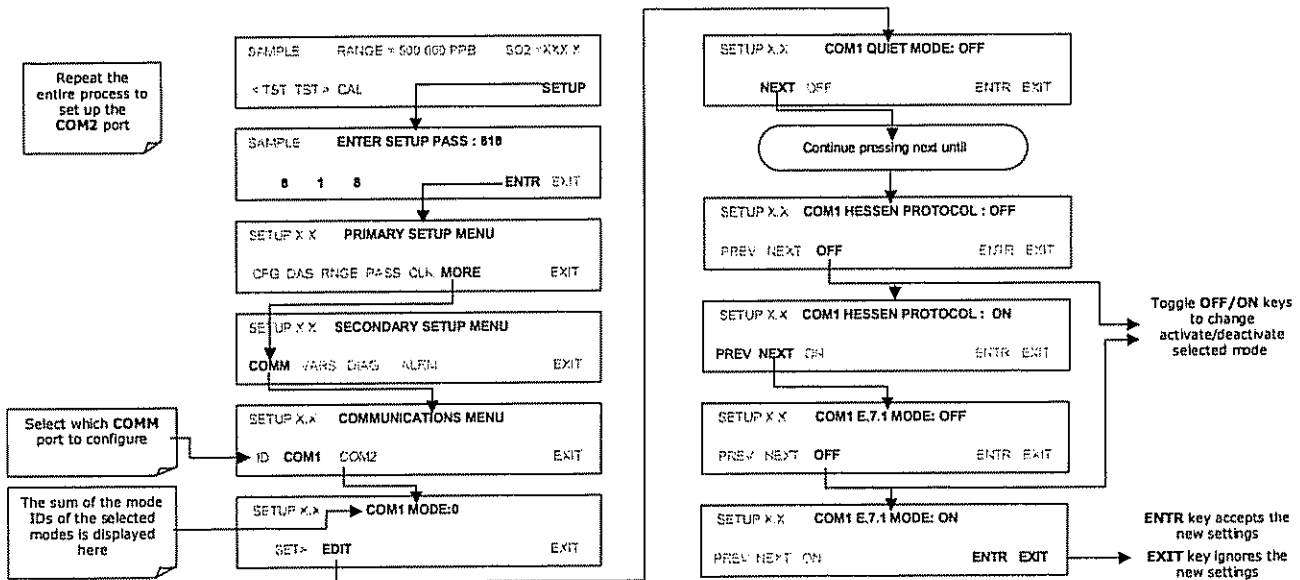

6.12.4.4. Selecting a Hessen Protocol Type

Currently there are two version of Hessen Protocol in use. The original implementation, referred to as **TYPE 1**, and a more recently released version, **TYPE 2** that has more flexibility when operating with instruments that can measure more than one type of gas. For more specific information about the difference between **TYPE 1** and **TYPE 2** download the *Manual Addendum for Hessen Protocol* from the Teledyne Instruments' web site: <http://www.teledyne-AI.com/manuals>.

To select a Hessen Protocol Type press:

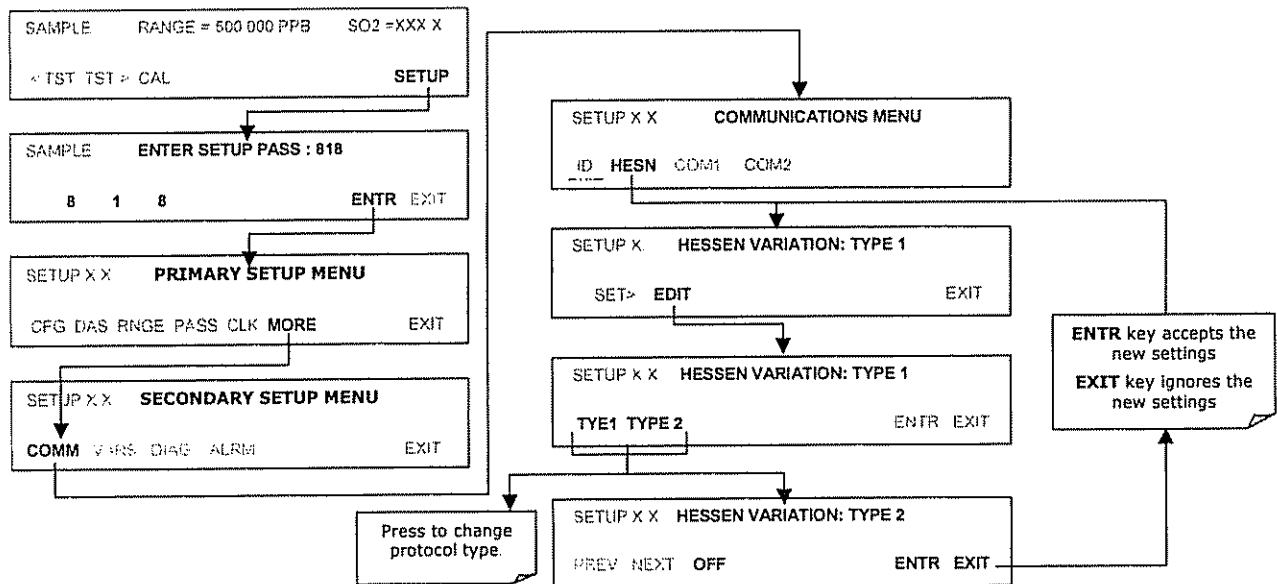

NOTE

While Hessen Protocol Mode can be activated independently for COM1 and COM2, The TYPE selection affects both Ports.

6.12.4.5. Setting The Hessen Protocol Response Mode

The Teledyne Instruments' implementation of Hessen Protocol allows the user to choose one of several different modes of response for the analyzer.

Table 6-28: 6400E Hessen Protocol Response Modes

MODE ID	MODE DESCRIPTION
CMD	This is the Default Setting. Responses from the instrument are encoded as the traditional command format. Style and format of responses depend on exact coding of the initiating command.
BCC	Responses from the instrument are always delimited with <STX> (at the beginning of the response, <ETX> (at the end of the response followed by a 2 digit Block Check Code (checksum), regardless of the command encoding.
TEXT	Responses from the instrument are always delimited with <CR> at the beginning and the end of the string, regardless of the command encoding.

To Select a Hessen response mode, press:

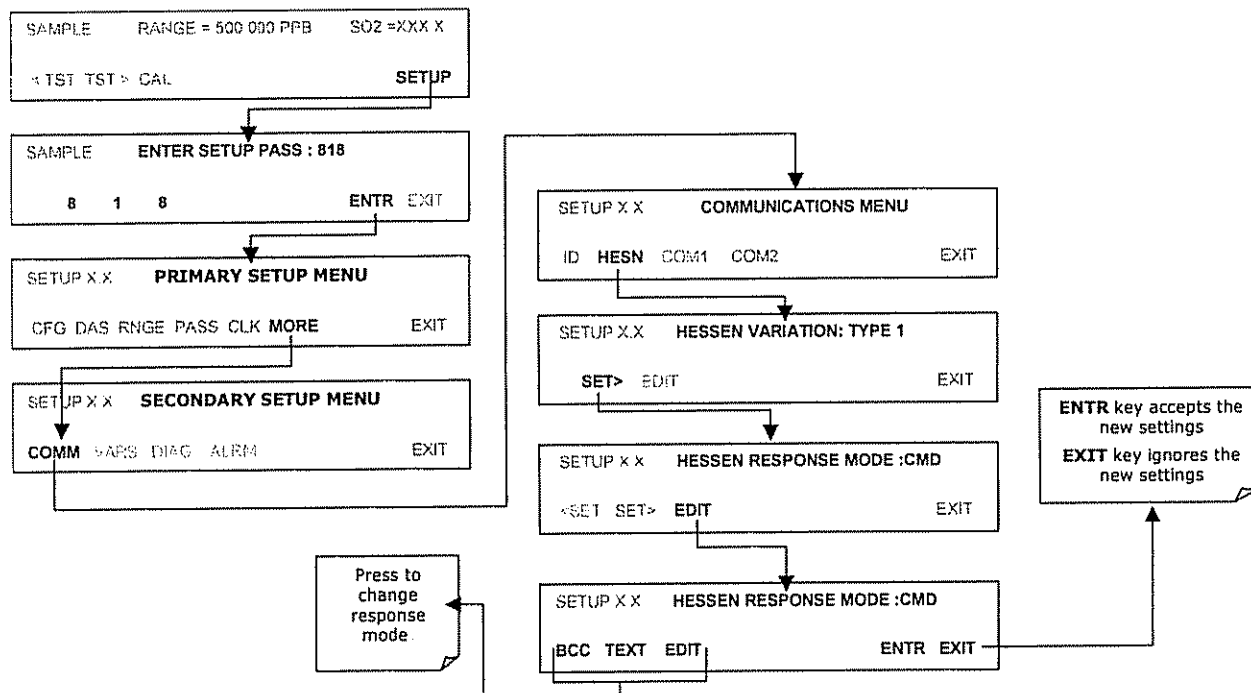

6.12.4.6. Hessen Protocol Gas ID

The Model 6400E Analyzer is a single gas instrument that measures SO₂. As such it's default gas ID has already been set to **110**. There is no need to change this setting.

6.12.4.7. Setting Hessen Protocol Status Flags

Teledyne Instruments' implementation of Hessen protocols includes a set of status bits that the instrument includes in responses to inform the host computer of its condition. Each bit can be assigned to one operational and warning message flag. The default settings for these bit/flags are:

Table 6-29: Default Hessen Status Bit Assignments

STATUS FLAG NAME		DEFAULT BIT ASSIGNMENT
WARNING FLAGS		
SAMPLE FLOW WARNING		0001
PMT DET WARNING		0002
UV LAMP WARNING		0002
HVPS WARNING		0004
DARK CAL WARNING		0008
RCELL TEMP WARNING		0010
IZS TEMP WARNING		0020
PMT TEMP WARNING		0040
INVALID CONC		0080
CONV TEMP WARNING		1000
OPERATIONAL FLAGS		
In Manual Calibration Mode		0200
In Zero Calibration Mode		0400
In Span Calibration Mode		0800
UNITS OF MEASURE FLAGS		
UGM		0000
MGM		2000
PPB		4000
PPM		6000E
SPARE/UNUSED BITS		100, 8000
UNASSIGNED FLAGS		
Box Temp Warning	Front Panel Warning	
Sample Press Warning	Analog Cal Warning	
System Reset	Cannot Dyn Zero	
Rear Board Not Detected	Cannot Dyn Span	
Relay Board Warning	Instrument Off	

NOTES:

It is possible to assign more than one flag to the same Hessen status bit. This allows the grouping of similar flags, such as all temperature warnings, under the same status bit.

Be careful not to assign conflicting flags to the same bit as each status bit will be triggered if any of the assigned flags is active.

To assign or reset the status flag bit assignments, press:

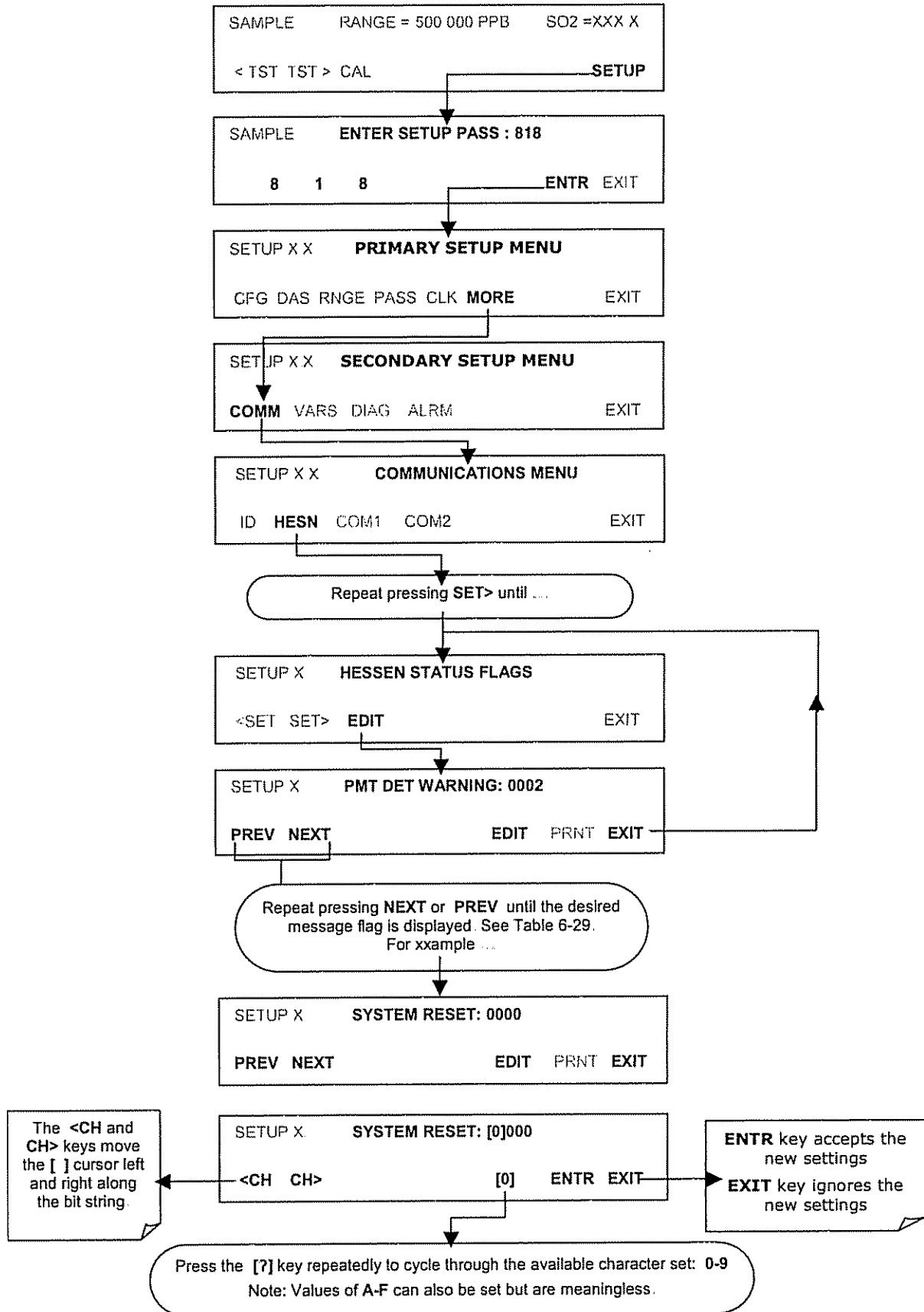

6.12.4.8. Instrument ID Code

Each instrument on a Hessen Protocol network must have a unique ID code. The 6400E is programmed with a default ID code of **100**. To change this code see Section 6.10.1

User Notes:

7. CALIBRATION PROCEDURES

This chapter describes the calibration procedures for the 6400E. All of the methods described in this section can be initiated and controlled through the COM ports.

NOTE

If you are using the 6400E for US-EPA controlled monitoring, see Chapter 8 for information on the EPA calibration protocol.

7.1. CALIBRATION PREPARATIONS

The calibration procedures in this section assume that the analog range and units of measure, range mode, and reporting range have already been selected for the analyzer. If this has not been done, please do so before continuing (see Section 6.7 for instructions).

NOTE:

It is recommended that the LAMP CAL routine (see Section 6.9.7) be performed prior to all calibration operation. This will allow the instrument to account for minor changes due to aging of the UV lamp.

7.1.1. REQUIRED EQUIPMENT, SUPPLIES, AND EXPENDABLES

Calibration of the Model 6400E analyzer requires a certain amount of equipment and supplies. These include, but are not limited to, the following:

- Zero-air source
- Sulfur dioxide span gas source
- Gas lines - all gas line materials should be Teflon-type or glass.
- A recording device such as a strip-chart recorder and/or data logger (optional).

7.1.2. ZERO AIR

Zero air is similar in chemical composition to the Earth's atmosphere but scrubbed of all components that might affect the analyzer's readings. For SO₂ measuring devices, zero air should be similar in composition to the sample gas but devoid of SO₂ and large amounts of hydrocarbons, nitrogen oxide (NO) and with a water vapor dew point $\leq -15^{\circ}\text{C}$.

Devices such as the API Model 701 zero air generator that condition ambient air by drying and removal of pollutants are available. We recommend this type of device for generating zero air.

7.1.3. CALIBRATION GAS STANDARDS & TRACEABILITY

Span gas is specifically mixed to match the chemical composition of the gas being measured at about 90% of the desired full measurement range. For example, if the measurement range is 500 ppb, the span gas should have an SO₂ concentration of about 450 ppb.

Span gases should be certified to a specific accuracy to ensure accurate calibration of the analyzer. Typical gas accuracy for SO₂ gases is 1 or 2 %. SO₂ standards should be mixed in nitrogen.

7.1.4. PERMEATION TUBES

Teledyne Analytical Instruments offers an IZS option operating with permeation devices. The accuracy of these devices is about ±5%. Whereas this may be sufficient for quick, daily calibration checks, we strongly recommend to use certified SO₂ span gases for accurate calibration.

Note

Applications requiring US-EPA equivalency do not allow permeation devices to be used as sources of span gas for calibration of the analyzer.

7.1.5. CALIBRATION GAS

All equipment used to produce calibration gases should be verified against standards of the National Institute for Standards and Technology (NIST). To ensure NIST traceability, we recommend to acquire cylinders of working gas that are certified to be traceable to NIST Standard Reference Materials (SRM). These are available from a variety of commercial sources.

Table 7-1: NIST-SRM's Available for Traceability of SO₂ Calibration Gases

NIST-SRM ⁴	TYPE	NOMINAL CONCENTRATION
1693a	Sulfur dioxide in N ₂	50 ppm
1694a	Sulfur dioxide in N ₂	100 ppm
1661a	Sulfur dioxide in N ₂	500 ppm

7.1.6. DATA RECORDING DEVICES

A strip chart recorder, data acquisition system or digital data acquisition system should be used to record data from the 6400E's serial or analog outputs. If analog readings are used, the response of the recording system should be checked against a NIST traceable voltage source or meter. Data recording device should be capable of bi-polar operation so that negative readings can be recorded. For electronic data recording, the 6400E provides an internal data acquisition system (iDAS), which is described in detail in Section 6.11.

Calibration and Calibration Check

Pressing the ENTR key during the following procedure re-calculates the stored values for OFFSET and SLOPE and alters the instrument's calibration.

If you wish to perform a calibration CHECK, do not press ENTR and see Section 7.3.

7.2. MANUAL CALIBRATION

The following section describes the basic method for manually calibrating the Model 6400E SO₂ analyzer.

STEP ONE: Connect the sources of zero air and span gas as shown below.

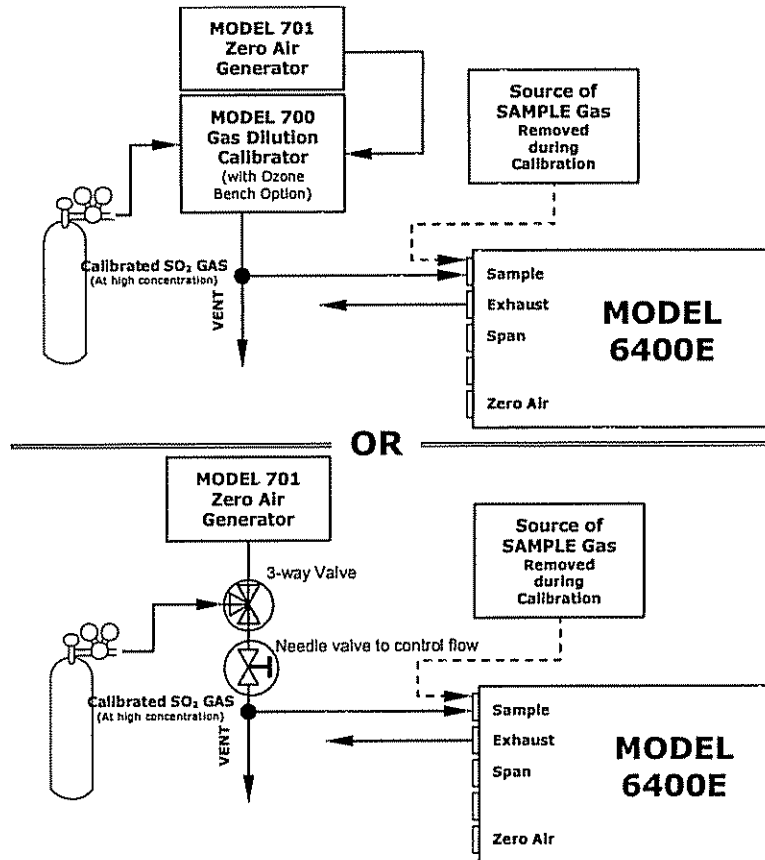
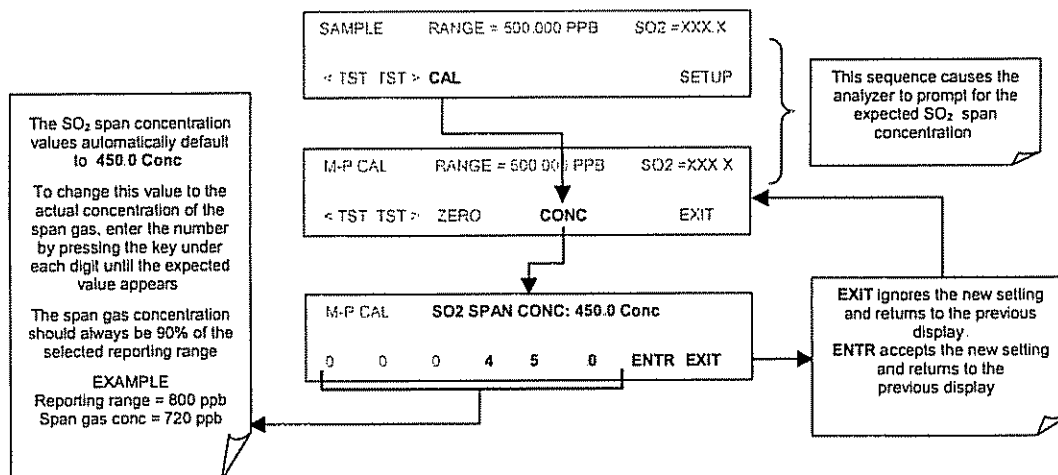
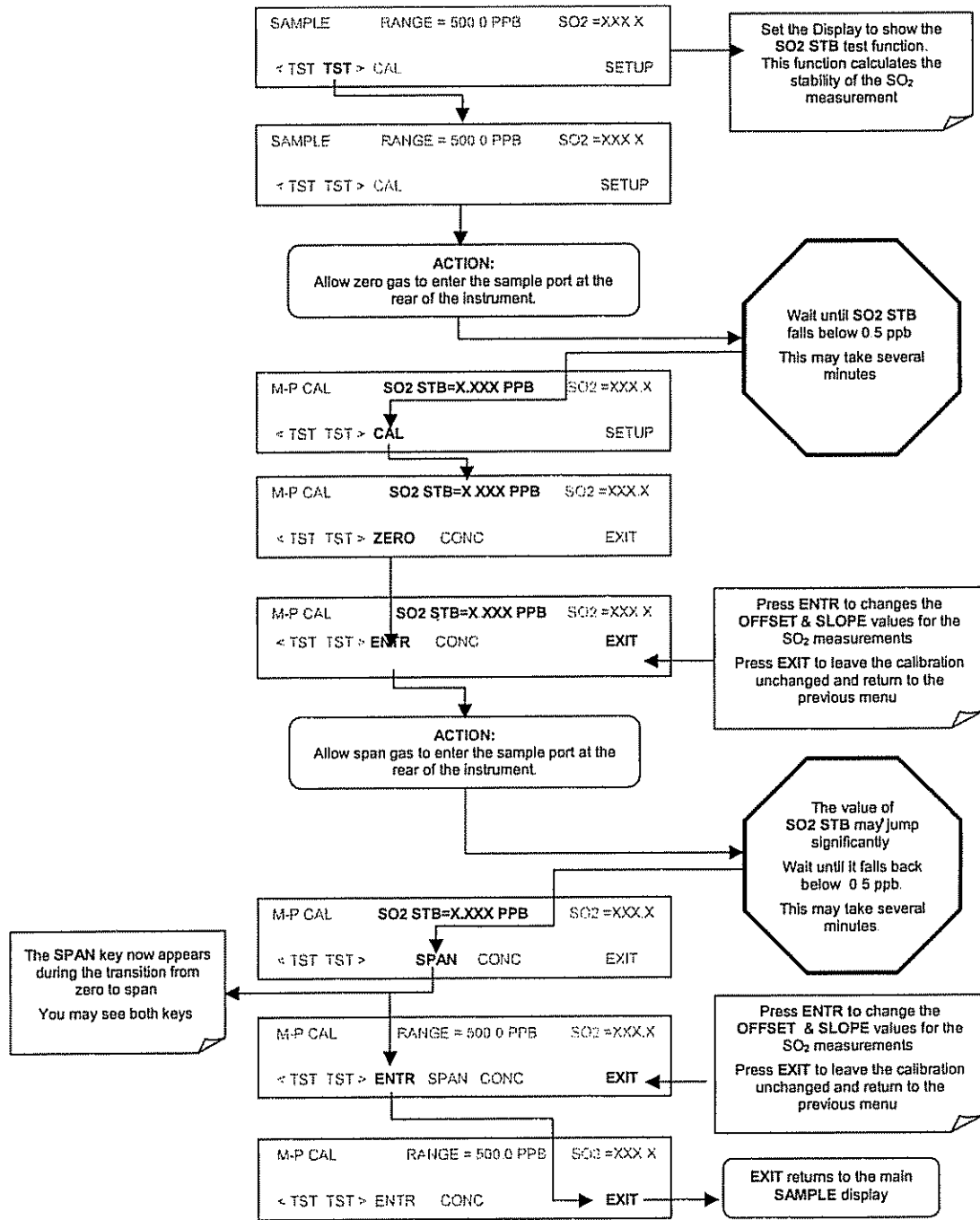

Figure 7-1: Setup for Manual Calibration without Z/S valve or IZS Option

STEP TWO: Set the expected SO₂ span gas concentrations. In this example the instrument is set for single (**SNGL**) range mode with a reporting range span of 500 ppb.



STEP THREE: Perform the zero/span calibration:



NOTE

If the ZERO or SPAN keys are not displayed during zero or span calibration, the measured concentration value is too different from the expected value and the analyzer does not allow to zero or span the instrument.

Consult Section 11.3 for more information on calibration problems.

7.3. MANUAL CALIBRATION CHECKS

Informal calibration checks, which only evaluate but do not alter the analyzer's response curve, are recommended as a regular maintenance item and in order to monitor the analyzer's performance. To carry out a calibration check rather than a full calibration, follow these steps.

STEP ONE: Connect the sources of zero air and span gas as shown in Figure 7.1.

STEP TWO: Perform the zero/span calibration check procedure:

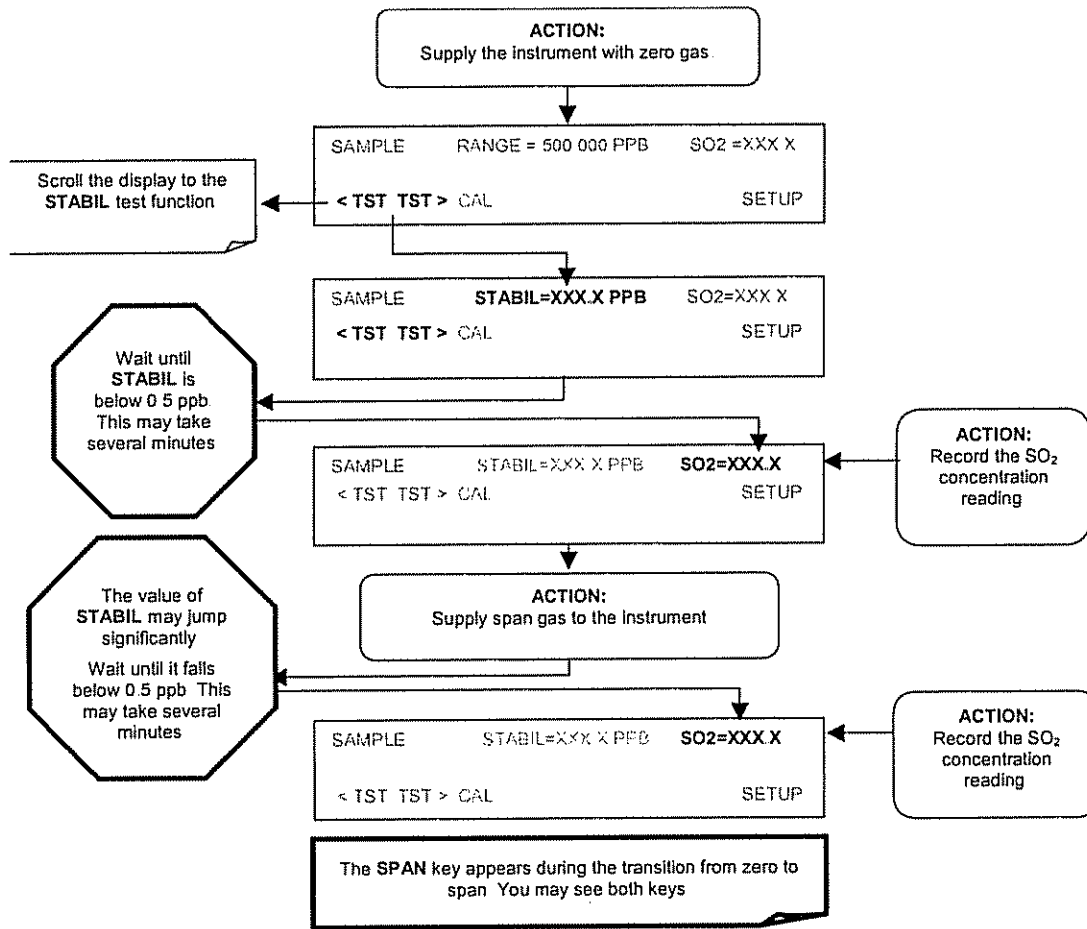

7.4. MANUAL CALIBRATION WITH ZERO/SPAN VALVES

Zero and Span calibrations using the Zero/Span Valve option are similar to that described in Section 7.2, except that:

- Zero air and span gas is supplied to the analyzer through the zero gas and span gas inlets rather than through the sample inlet.
- The zero and cal operations are initiated directly and independently with dedicated keys (**CALZ** & **CALS**)

STEP ONE: Connect the sources of zero air and span gas to the respective ports on the rear panel (see Figure 3-1) as shown below.

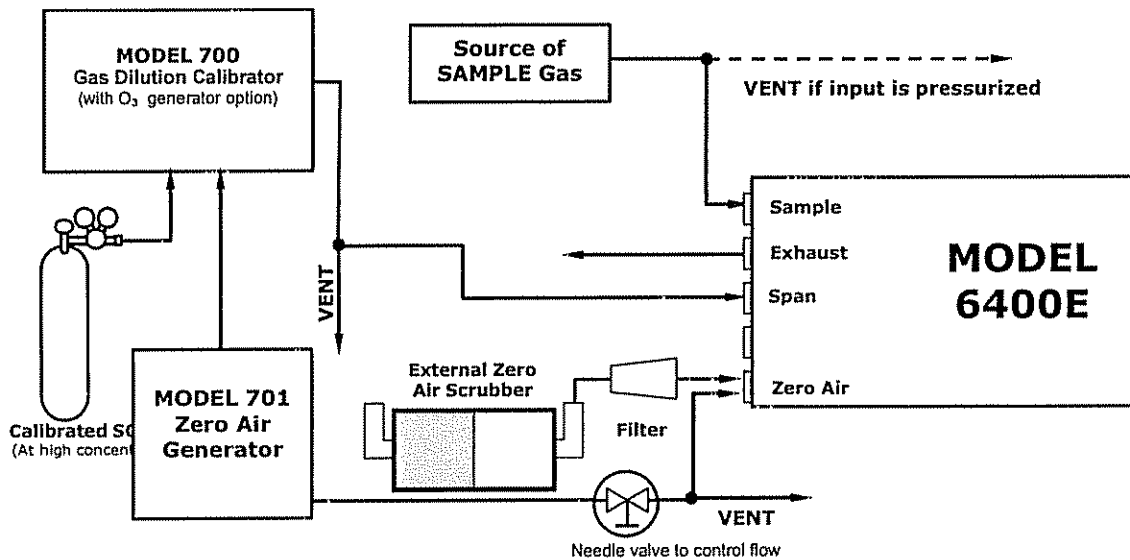
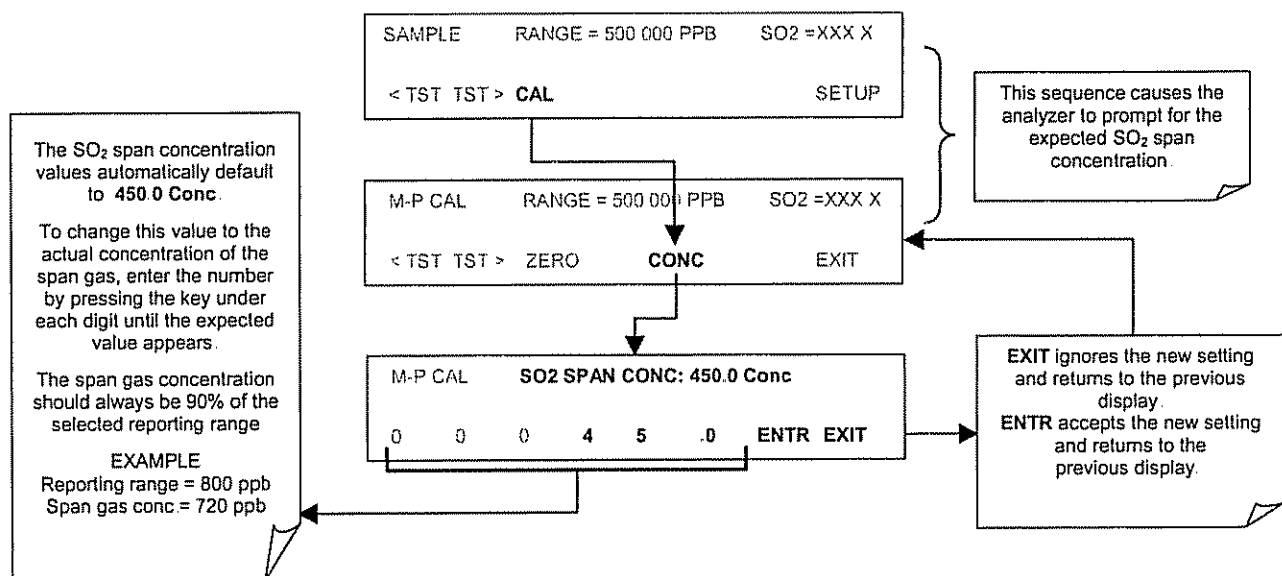
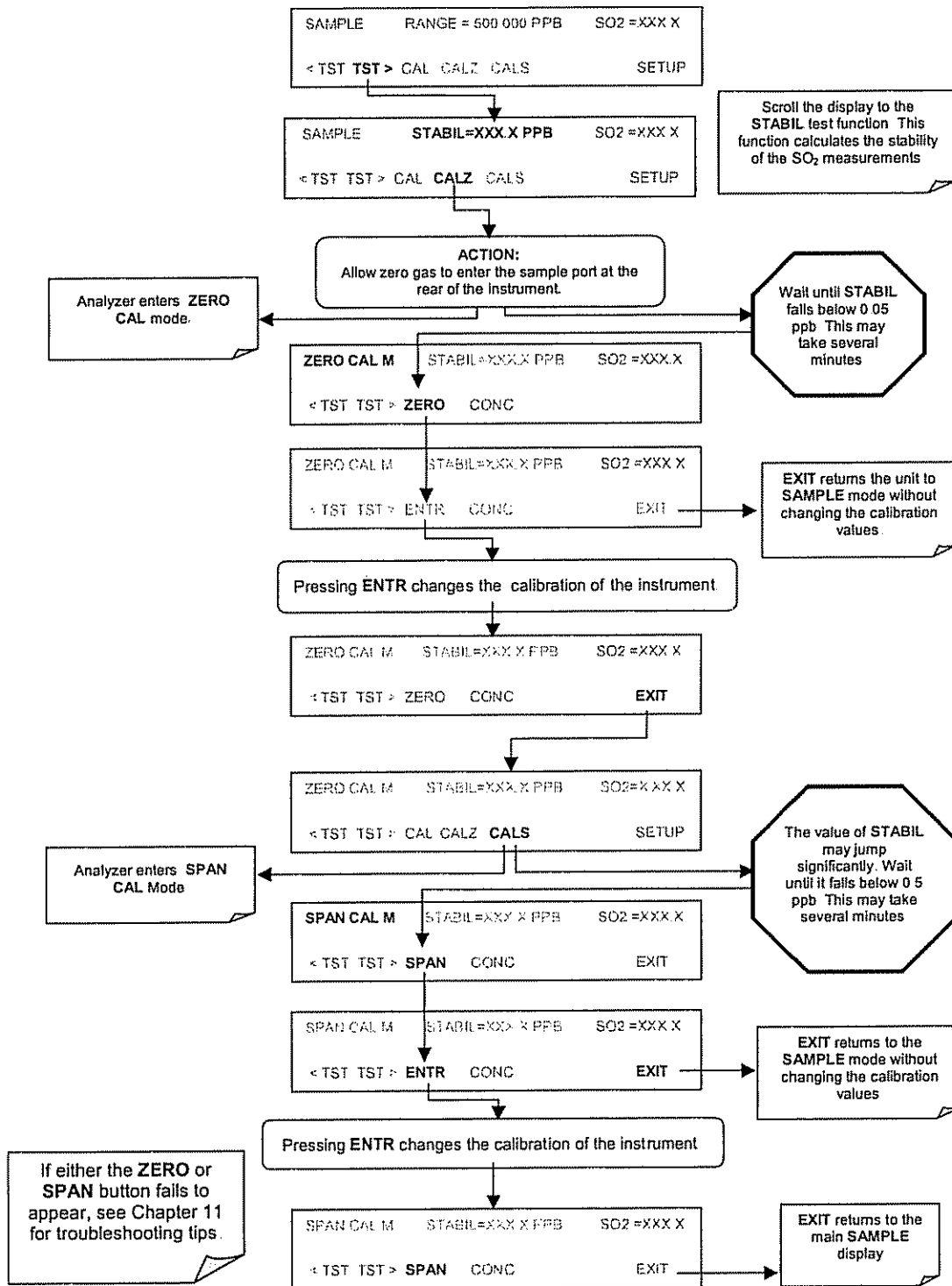

Figure 7-2: Setup for Manual Calibration with Z/S Valve Option Installed

Step Two: Set the expected SO₂ span gas value:



Step Three: Perform the calibration or calibration check according to the following flow chart:



7.5. MANUAL CALIBRATION WITH IZS OPTION

Under the best conditions, the accuracy off the SO₂ effusion rate of the IZS option's permeation tube is about ±5%. This can be subject to significant amounts of drift as the tube ages and the amount of SO₂ contained in the tube is depleted. Whereas this may be sufficient for informal calibration checks, it is not adequate for formal calibrations and is not approved for use by the US EPA as a calibration source.

Therefore, for formal calibrations of an instrument with an IZS option installed the following provisions must be followed.

Zero air and span gas must be supplied to the analyzer through the sample gas inlet as depicted in Figure 7-1 of Section 7.2.

The calibration procedure must be initiated using the **CAL** key, not the **CALZ** and **CALS** keys, using the procedure defined in Section 7.2.

Using the **CAL** key does not activate the zero/span or sample/cal valves of the IZS option, thus allowing the introduction of zero air and sample gas through the sample port from more accurate, external sources such as a calibrated bottle of SO₂ or a Model 700 Dilution Calibrator.

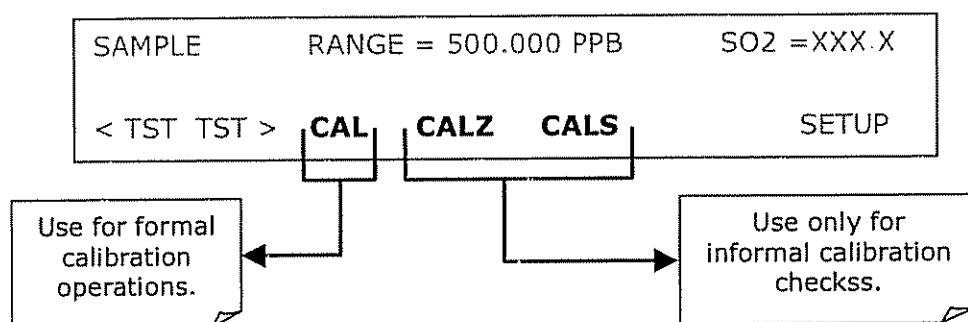

7.6. MANUAL CALIBRATION CHECKS WITH Izs OR ZERO/SPAN VALVES

Zero and span checks using the zero/span valve or IZS option are similar to that described in Section 7.3, except:

On units with an IZS option installed, zero air and span gas are supplied to the analyzer through the zero gas inlet and from ambient air.

On units with a zero/span valve option installed, zero air and span gas are supplied to the analyzer through the zero gas and span gas inlets from two different sources.

The zero and calibration operations are initiated directly and independently with dedicated keys CALZ and CALS.

To perform a manual calibration check of an analyzer with a zero/span valve or IZS Option installed, use the following method

STEP ONE: Connect the sources of Zero Air and Span Gas as shown below.

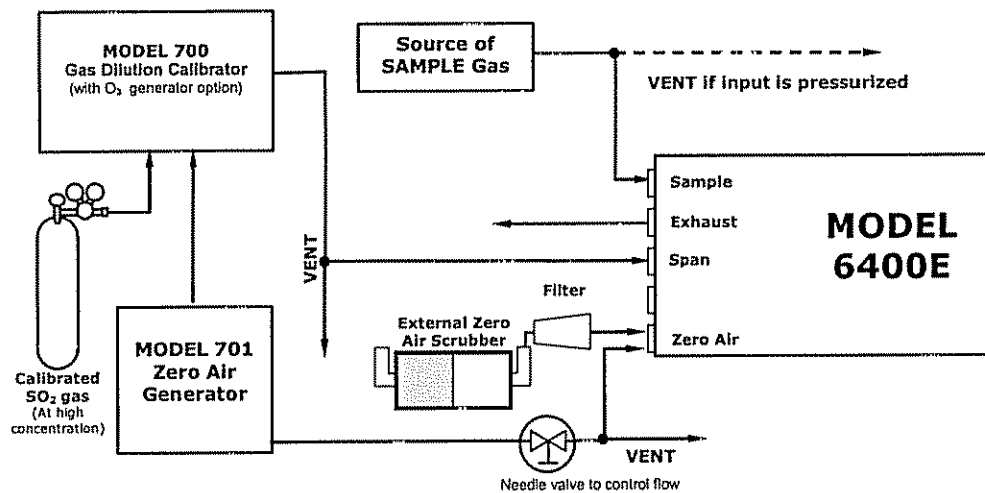

Internal Zero/Span Option (IZS) – Option 51

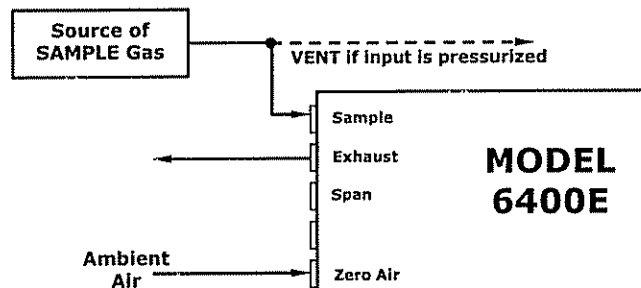
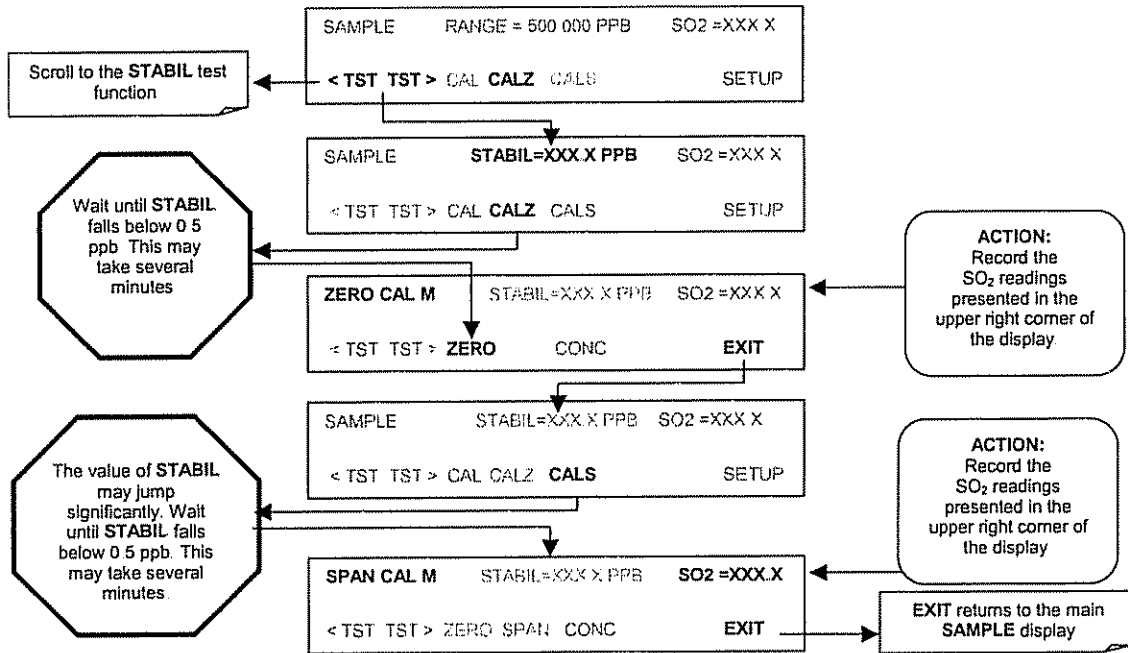

Figure 7-3: Setup for Manual Calibration Check with Z/S Valve or IZS Option

STEP TWO: Perform the zero/span check.



7.7. MANUAL CALIBRATION IN DUAL OR AUTO REPORTING RANGE MODES

When the analyzer is in either Dual or Auto Range modes the user must run a separate calibration procedure for each range. After pressing the **CAL**, **CALZ** or **CALS** keys the user is prompted for the range that is to be calibrated as seen in the **CALZ** example below:

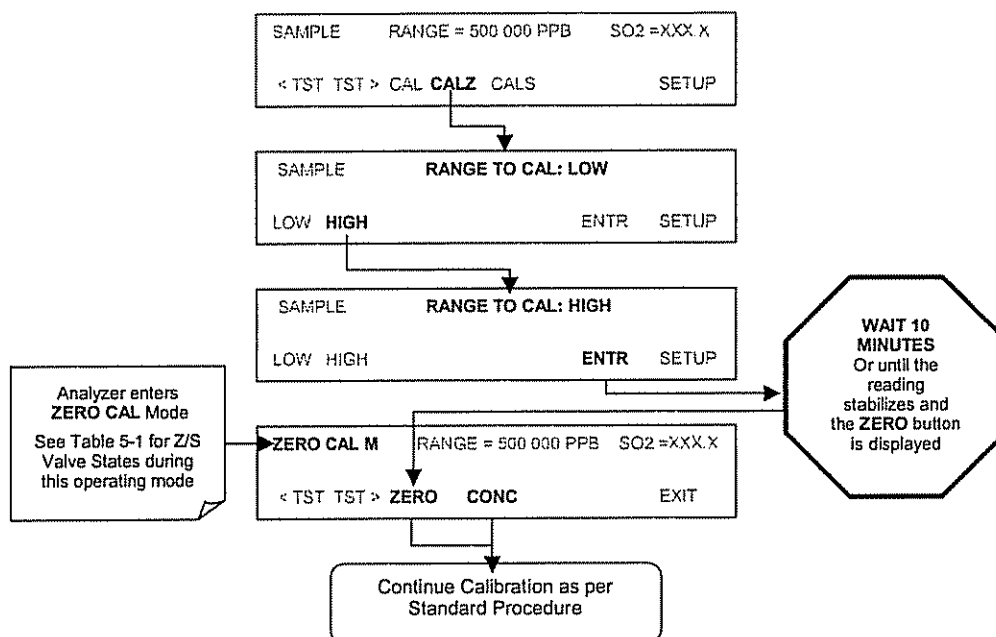

Once this selection is made, the calibration procedure continues as previously described in Sections 7.2 through 7.6. The other range may be calibrated by starting over from the main **SAMPLE** display.

7.7.1. CALIBRATION WITH REMOTE CONTACT CLOSURES

Contact closures for controlling calibration and calibration checks are located on the rear panel **CONTROL IN** connector. Instructions for setup and use of these contacts can be found in Section 6.12.1.2.

When the appropriate contacts are closed for at least 5 seconds, the instrument switches into zero, low span or high span mode and the internal zero/span valves will be automatically switched to the appropriate configuration. The remote calibration contact closures may be activated in any order. It is recommended that contact closures remain closed for at least 10 minutes to establish a reliable reading; the instrument will stay in the selected mode for as long as the contacts remain closed.

If contact closures are used in conjunction with the analyzer's AutoCal (see Section 7.8) feature and the AutoCal attribute **CALIBRATE** is enabled, the 6400E will not re-calibrate the analyzer until the contact is opened. At this point, the new calibration values will be recorded before the instrument returns to **SAMPLE** mode.

If the AutoCal attribute **CALIBRATE** is disabled, the instrument will return to **SAMPLE** mode, leaving the instrument's internal calibration variables unchanged.

7.8. AUTOMATIC CALIBRATION (AUTOCAL)

The AutoCal system allows unattended, periodic operation of the zero/span valve options by using the analyzer's internal time of day clock. AutoCal operates by executing user-defined sequences to initiate the various calibration modes of the analyzer and to open and close valves appropriately. It is possible to program and run up to three separate sequences (**SEQ1**, **SEQ2** and **SEQ3**). Each sequence can operate in one of three modes or be disabled.

Table 7-2: AutoCal Modes

MODE	ACTION
DISABLED	Disables the sequence
ZERO	Causes the sequence to perform a zero calibration or check
ZERO-SPAN	Causes the sequence to perform a zero and span concentration calibration or check
SPAN	Causes the sequence to perform a span concentration calibration or check

Each mode has seven parameters that control operational details of the sequence.

Table 7-3: AutoCal Attribute Setup Parameters

ATTRIBUTE NAME	ACTION
Timer Enabled	Turns on the Sequence timer
Starting Date	Sequence will operate on Starting Date
Starting Time	Sequence will operate at Starting Time ^{1, 2}
Delta Days	Number of days to skip between each sequence
Delta Time	Incremental delay on each Delta Day that the sequence starts.
Duration	Duration of the sequence in minutes
Calibrate	Enable to do dynamic zero/span calibration, disable to do a cal check only. This must be set to OFF for units used in US EPA applications and with IZS option installed.

¹ The programmed STARTING_TIME must be a minimum of 5 minutes later than the real time clock (See Section 6.6 for setting real time clock).

² Avoid setting two or more sequences at the same time of the day. Any new sequence which is initiated whether from a timer, the COM ports, or the contact closure inputs will override any sequence which is in progress.

NOTE

If at any time an illegal entry is selected (Example: Delta Days > 367) the ENTR key will disappear from the display.

WARNING!

The CALIBRATE attribute must always be set to OFF for analyzers used in US EPA controlled applications that have IZS option installed.

Calibration of instruments used in US EPA related applications should only be performed using external sources of zero air and span gas with an accuracy traceable to EPA or NIST standards and supplied through the analyzer's sample port (see Section 7.2).

The following example sets Sequence2 to carry out a zero-span calibration every other day starting at 01:00 on September 4, 2002, lasting 15 minutes. This sequence will start 0.5 hours later each day.

Table 7-4: Example Auto-Cal Sequence

MODE AND ATTRIBUTE	VALUE	COMMENT
SEQUENCE	2	Define Sequence #2
MODE	ZERO-SPAN	Select Zero and Span Mode
TIMER ENABLE	ON	Enable the timer
STARTING DATE	Sept. 4, 2002	Start after Sept 4, 2002
STARTING TIME	01:00	First Span starts at 01:00
DELTA DAYS	2	Do Sequence #2 every other day
DELTA TIME	00:30	Do Sequence #2 0.5 h later each day
DURATION	15.0	Operate Span valve for 15 min
CALIBRATE	ON	The instrument will re-set the slope and offset values for the SO ₂ channel at the end of the AutoCal sequence

To program the sample sequence shown above:

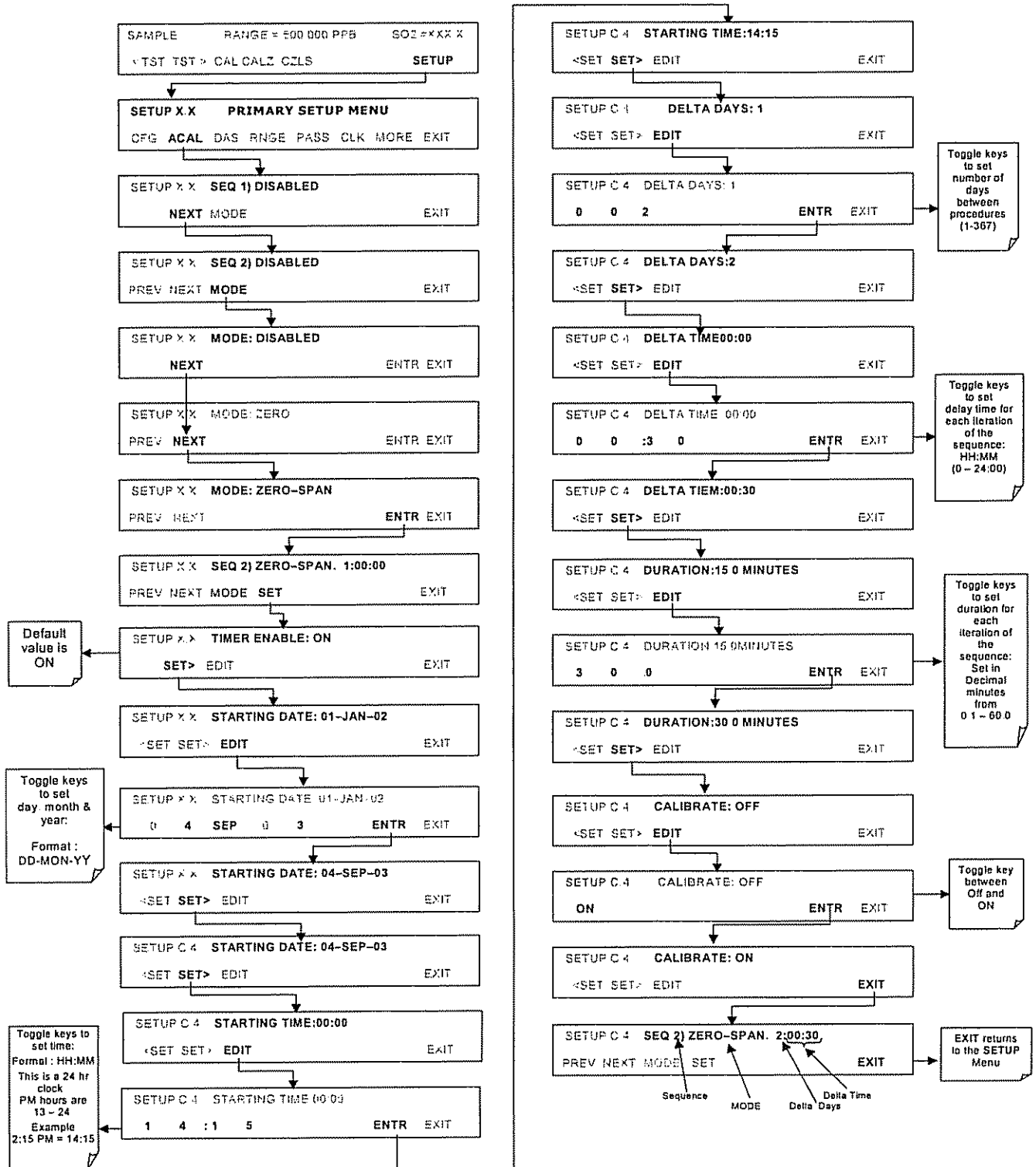

With dynamic calibration turned on, the state of the internal setup variables **DYN_SPAN** and **DYN_ZERO** is set to **ON** and the instrument will reset the slope and offset values for the SO₂ response each time the AutoCal program runs. This continuous re-adjustment of calibration parameters can often mask subtle fault conditions in the analyzer. It is recommended that, if dynamic calibration is enabled, the analyzer's test functions, slope and offset values be checked frequently to assure high quality and accurate data from the instrument.

7.9. CALIBRATION QUALITY

After completing one of the calibration procedures described above, it is important to evaluate the analyzer's calibration **SLOPE** and **OFFSET** parameters. These values describe the linear response curve of the analyzer. The values for these terms, both individually and relative to each other, indicate the quality of the calibration. To perform this quality evaluation, you will need to record the values of both test functions (see Section 6.2.1 or Appendix A-3), all of which are automatically stored in the iDAS channel **CALDAT** for data analysis, documentation and archival.

Make sure that these parameters are within the limits listed in the following Table.

Table 7-5: Calibration Data Quality Evaluation

FUNCTION	MINIMUM VALUE	OPTIMUM VALUE	MAXIMUM VALUE
SLOPE	-0.700	1.000	1.300
OFFS	50.0 mV	n/a	250.0 mV

These values should not be significantly different from the values recorded on the TAI *Final Test and Validation Data* sheet that was shipped with your instrument. If they are, refer to the troubleshooting Chapter 11.

8. EPA PROTOCOL CALIBRATION

8.1. CALIBRATION REQUIREMENTS

If the 6400E is to be used for EPA SLAMS monitoring, it must be calibrated in accordance with the instructions in this section.

In order to insure that high quality, accurate measurements are obtained at all times, the 6400E must be calibrated prior to use. A quality assurance program centered on this aspect and including attention to the built-in warning features of the 6400E, periodic inspection, regular zero/span checks and routine maintenance is paramount to achieving this.

The US EPA strongly recommends obtaining a copy of the *Quality Assurance Handbook for Air Pollution Measurement Systems, Volume II, Part I* (abbreviated *Q.A. Handbook Volume II*).

Special attention should be paid to Section 2.9 of the EPA handbook which deals with fluorescence based SO₂ analyzers and upon which most of this section is based. Specific regulations regarding the use and operation of ambient sulfur dioxide analyzers can be found in 40 CFR 50 and 40 CFR 58.

8.1.1. CALIBRATION OF EQUIPMENT

In general, calibration is the process of adjusting the gain and offset of the 6400E against some recognized standard. The reliability and usefulness of all data derived from any analyzer depends primarily upon its state of calibration. In this section the term dynamic calibration is used to express a multipoint check against known standards and involves introducing gas samples of known concentration into the instrument in order to adjust the instrument to a predetermined sensitivity and to produce a calibration relationship. This relationship is derived from the instrumental response to successive samples of different known concentrations. As a minimum, three reference points and a zero point are recommended to define this relationship. The true values of the calibration gas must be traceable to NIST-SRM's See Table 7.1.

All monitoring instrument systems are subject to some drift and variation in internal parameters and cannot be expected to maintain accurate calibration over long periods of time. Therefore, it is necessary to dynamically check the calibration relationship on a predetermined schedule. Zero and span checks must be used to document that the data remains within control limits. These checks are also used in data reduction and validation. Table 8-1 summarizes the initial quality assurance activities for calibrating equipment. Table 8-2 is a matrix for the actual dynamic calibration procedure.

Calibrations should be carried out at the field monitoring site. The Analyzer should be in operation for at least several hours (preferably overnight) before calibration so that it is fully warmed up and its operation has stabilized. During the calibration, the 6400E should be in the CAL mode, and therefore sample the test atmosphere through all components used during normal ambient sampling and through as much of the ambient air inlet system as is practicable. If the Instrument will be used on more than one range (i.e. **DUAL** or **AUTO** ranges), it should be calibrated separately on each applicable range. Calibration documentation should be maintained with each analyzer and also in a central backup file.

Table 8-1: Activity Matrix for Calibration Equipment & Supplies

EQUIPMENT & SUPPLIES	ACCEPTANCE LIMITS	FREQUENCY AND METHOD OF MEASUREMENT	ACTION IF REQUIREMENTS ARE NOT MET
Recorder	Compatible with output signal of analyzer; min. chart width of 150 mm (6 in) is recommended	Check upon receipt	Return equipment to supplier
Sample line and manifold	Constructed of PTFE or glass	Check upon receipt	Return equipment to supplier
Calibration equipment	Meets guidelines of reference 1 and Section 2.3.2 (Q.A. Handbook)	See Section 2.3.9 (Q.A. Handbook)	Return equipment/ supplies to supplier or take corrective action
Working standard SO ₂ cylinder gas or SO ₂ permeation tube	Traceable to NIST-SRM meets limits in traceability protocol for accuracy and stability (see Section 2.0.7, Q.A. Handbook)	Analyzed against NIST-SRM; see protocol in Section 2.0.7, Q.A. Handbook	Obtain new working standard and check for traceability
Zero air	Clean dry ambient air, free of contaminants that cause detectable response with the SO ₂ analyzer.	See Section 2.9.2 (Q.A. Handbook)	Obtain air from another source or regenerate.
Record form	Develop standard forms	N/A	Revise forms as appropriate
Audit equipment	Must not be the same as used for calibration	System must be checked out against known standards	Locate problem and correct or return to supplier

Table 8-2: Activity Matrix for Calibration Procedure

EQUIPMENT & SUPPLIES	ACCEPTANCE LIMITS	FREQUENCY AND METHOD OF MEASUREMENT	ACTION IF REQUIREMENTS ARE NOT MET
Calibration gases	NIST traceable	Assayed against an NIST-SRM semi-annually, Sec. 2.0.7, (Q.A. Handbook)	Working gas standard is unstable, and/or measurement method is out of control; take corrective action such as obtaining new calibration gas.
Dilution gas	Zero air, free of contaminants	See Section 2.9.2 (Q.A. Manual)	Return to supplier or take appropriate action with generation system
Multi-point calibration	Use calibration procedure in Subsec. 2.2 (Q.A. Handbook); also <u>Federal Register</u>	Perform at least once every quarter or anytime a level span check indicates a discrepancy, or after maintenance which may affect the calibration; Subsec 2.5 (Q.A. Manual)	Repeat the calibration

8.1.2. DATA RECORDING DEVICE

Either a strip chart recorder, data acquisition system, digital data acquisition system should be used to record the data from the Mode; 6400E RS-232 port or analog outputs. If analog readings are being used, the response of that system should be checked against a NIST referenced voltage source or meter. Data recording device should be capable of bi-polar operation so that negative readings can be recorded.

8.1.3. RECOMMENDED STANDARDS FOR ESTABLISHING TRACEABILITY

To assure data of desired quality, two considerations are essential: (1) the measurement process must be in statistical control at the time of the measurement and (2) the systematic errors, when combined with the random variation in the measurement process, must result in a suitably small uncertainty.

Evidence of good quality data includes documentation of the quality control checks and the independent audits of the measurement process by recording data on specific forms or on a quality control chart and by using materials, instruments, and measurement procedures that can be traced to appropriate standards of reference. To establish traceability, data must be obtained routinely by repeat measurements of standard reference samples (primary, secondary, and/or working standards). More specifically, working calibration standards must be traceable to standards of higher accuracy, such as those listed in Table 7-1.

Cylinders of working gas traceable to NIST-SRM's (called EPA Protocol Calibration Gas) are also commercially available (from sources such as Scott Specialty Gases, etc.).

8.1.4. EPA CALIBRATION USING PERMEATION TUBES

TAI does not recommend the use of permeation tubes as a source of span gas for EPA protocol calibration operations.

8.1.5. CALIBRATION FREQUENCY

To ensure accurate measurements of the SO₂ concentrations, calibrate the analyzer at the time of installation, and re-calibrate it:

- No later than three months after the most recent calibration or performance audit which indicated analyzer calibration to be acceptable.
- An interruption of more than a few days in analyzer operation.
- Any repairs which might affect its calibration.
- Physical relocation of the analyzer.
- Any other indication (including excessive zero or span drift) of possible significant inaccuracy of the analyzer.

Following any of the activities listed above, the zero and span should be checked to determine if a calibration is necessary. If the analyzer zero and span drifts exceed locally established calibration

units or the calibration limits in Section 2.0.9, Subsection 9.1.3 (Q.A. Handbook), a calibration should be performed.

8.1.6. RECORD KEEPING

Record keeping is a critical part of all quality assurance programs. Standard forms similar to those that appear in this manual should be developed for individual programs. Three things to consider in the development of record forms are:

- Does the form serve a necessary function?
- Is the documentation complete?
- Will the forms be filed in such a manner that they can easily be retrieved when needed?

8.1.7. SUMMARY OF QUALITY ASSURANCE CHECKS

The following items should be checked on a regularly scheduled basis to assure high quality data from the 6400E. See Table 8-3 for a summary of activities. Also the QA Handbook should be checked for specific procedures.

Table 8-3: Activity Matrix for Quality Assurance Checks

CHARACTERISTIC	ACCEPTANCE LIMITS	FREQUENCY AND METHOD OF MEASUREMENT	ACTION IF REQUIREMENTS ARE NOT MET
Shelter temperature	Mean temperature between 22°C and 28°C (72° and 82°F), daily fluctuations not greater than ±2°C	Check thermograph chart weekly for variations greater than ±2°C (4°F)	Mark strip chart for the affected time period Repair or adjust temperature control
Sample introduction system	No moisture, foreign material, leaks, obstructions; sample line connected to manifold	Weekly visual inspection	Clean, repair, or replace as needed
Recorder	Adequate ink & paper Legible ink traces Correct chart speed and range Correct time	Weekly visual inspection	Replenish ink and paper supply Adjust time to agree with clock; note on chart
Analyzer operational settings	TEST measurements at nominal values 2. 6400E in SAMPLE mode	Weekly visual inspection	Adjust or repair as needed
Analyzer operational check	Zero and span within tolerance limits as described in Subsec. 9.1.3 of Sec. 2.0.9 (Q.A. Handbook)	Level 1 zero/span every 2 weeks; Level 2 between Level 1 checks at frequency desired analyzer by user	Find source of error and repair After corrective action, re-calibrate analyzer
Precision check	Assess precision as described in Sec. 2.0.8 and Subsec. 3.4.3 (Ibid.)	Every 2 weeks, Subsec. 3.4.3 (Ibid.)	Calc, report precision, Sec. 2.0.8 (Ibid.)

8.2. LEVEL 1 CALIBRATIONS VERSUS LEVEL 2 CHECKS

Essential to quality assurance are scheduled checks for verifying the operational status of the monitoring system. The operator should visit the site at least once each week. It is recommended Level 1 zero and span check conducted on the analyzer every two weeks. Level 2 zero and span checks should be conducted at a frequency desired by the user. Definitions of these terms are given in Table 8-4.

In addition, an independent precision check between 0.08 and 0.10 ppm must be carried out at least once every two weeks. Table 8-3 summarizes the quality assurance activities for routine operations. A discussion of each activity appears in the following sections.

To provide for documentation and accountability of activities, a checklist should be compiled and then filled out by the field operator as each activity is completed.

Table 8-4: Definition of Level 1 and Level 2 Zero and Span Checks
(from Section 2.0.9 of Q.A. Handbook for Air Pollution Measurement Systems)

LEVEL 1 ZERO AND SPAN CALIBRATION	LEVEL 2 ZERO AND SPAN CHECK
<p>A Level 1 zero and span calibration is a simplified, two-point analyzer calibration used when analyzer linearity does not need to be checked or verified. (Sometimes when no adjustments are made to the analyzer, the Level 1 calibration may be called a zero/span check, in which case it must not be confused with a Level 2 zero/span check.) Since most analyzers have a reliably linear or near-linear output response with concentration, they can be adequately calibrated with only two concentration standards (two-point concentration). Furthermore, one of the standards may be zero concentration, which is relatively easily obtained and need not be certified. Hence, only one certified concentration standard is needed for the two-point (Level 1) zero and span calibration. Although lacking the advantages of the multipoint calibration, the two-point zero and span calibration--because of its simplicity--can be (and should be) carried out much more frequently. Also, two-point calibrations are easily automated. Frequency checks or updating of the calibration relationship with a two-point zero and span calibration improves the quality of the monitoring data by helping to keep the calibration relationship more closely matched to any changes (drifts) in the analyzer response.</p>	<p>A Level 2 zero and span check is an "unofficial" check of an analyzer's response. It may include dynamic checks made with uncertified test concentrations, artificial stimulation of the analyzer's detector, electronic or other types of checks of a portion of the analyzer, etc.</p> <p>Level 2 zero and span checks are <u>not</u> to be used as a basis for analyzer zero or span adjustments, calibration updates, or adjustment of ambient data. They are intended as quick, convenient checks to be used between zero and span calibrations to check for possible analyzer malfunction or calibration drift. Whenever a Level 2 zero or span check indicates a possible calibration problem, a Level 1 zero and span (or multipoint) calibration should be carried out before any corrective action is taken.</p> <p>If a Level 2 zero and span check is to be used in the quality control program, a "reference response" for the check should be obtained immediately following a zero and span (or multipoint) calibration while the analyzer's calibration is accurately known. Subsequent Level 2 check responses should then be compared to the most recent reference response to determine if a change in response has occurred. For automatic Level 2 zero and span checks, the first scheduled check following the calibration should be used for the reference response. It should be kept in mind that any Level 2 check that involves only part of the analyzer's system cannot provide information about the portions of the system not checked and therefore cannot be used as a verification of the overall analyzer calibration.</p>

8.3. ZERO AND SPAN CHECKS

A system of Level 1 and Level 2 zero span checks (see Table 8-4) is recommended. These checks must be conducted in accordance with the specific guidance given in Subsection 9.1 of Section 2.0.9 (Q.A. Handbook). It is recommended Level 1 zero and span checks conducted every two weeks. Level 2 checks should be conducted in between the Level 1 checks at a frequency desired by the user. Span concentrations for both levels should be between 70 and 90% of the measurement range.

Zero and span data are to be used to:

- Provide data to allow analyzer adjustment for zero and span drift;
- Provide a decision point on when to calibrate the analyzer;
- Provide a decision point on invalidation of monitoring data.

Items 1 and 2 are described in detail in Subsection 9.1.3 of Section 2.0.9 (Q.A. Handbook). Item 3 is described in Subsection 9.1.4 of the same section.

Refer to the Troubleshooting Chapter 11 of this manual if the instrument is not within the allowed variations.

8.3.1. ZERO/SPAN CHECK PROCEDURES

The Zero and Span calibration can be checked a variety of different ways. They include:

- Manual Zero/Span Check - Zero and Span can be checked from the front panel keyboard. The procedure is in Section 7.3 and 7.6 of this manual.
- Automatic Zero/Span Checks - After the appropriate setup, Z/S checks can be performed automatically every night. See Section 7.8 of this manual for setup and operation procedures.
- Zero/Span checks via remote contact closure = Zero/Span checks can be initiated via remote contact closures on the rear panel. See Section 7.7.1 of this manual.
- Zero/Span via RS-232 port - Z/S checks can be controlled via the RS-232 port. See Section 6.10.3. & 6.12 and Appendix A-6 of this manual for more details.

8.4. PRECISIONS CALIBRATION PROCEDURES AND CHECKS

Calibration must be performed with a calibrator that meets all conditions specified in Subsection 2.9.2 (Q.A. Handbook). The user should be sure that all flow meters are calibrated under the conditions of use against a reliable standard. All volumetric flow rates should be corrected to 25°C (77°F) and 760mm (29.92in) Hg. Make sure the calibration system can supply the range of the concentration at a sufficient flow over the whole range of concentration that will be encountered during calibration.

All operational adjustments to the 6400E should be completed prior to the calibration. The following software features must be set into the desired state before calibration.

- Single range selection. See Section 6.7.4 of this manual. If the instrument will be used more than one range, it should be calibrated separately on each applicable range.
- Automatic temperature/pressure compensation should be enabled. See Section 6.8.
- Alternate units, make sure ppb units are selected for EPA monitoring. See Section 6.7.7.

The analyzer should be calibrated on the same range used for monitoring. If the **AUTO** range mode is selected, the highest of the ranges will result in the most accurate calibration, and should be used.

8.4.1. PRECISION CALIBRATION

To perform a precision calibration, the instrument set up; input sources of zero air and sample gas and; procedures should conform to those described in Section 7.2 for analyzer's with no valve options or with an IZS valve option installed and Section 7.5 for analyzer's with Z/S options installed with the following exception:

8.4.2. PRECISION CHECK

A periodic check is used to assess the data for precision. A one-point precision check must be carried out at least once every 2 weeks on each analyzer at an SO₂ concentration between 0.08 and 0.10 ppm. The analyzer must be operated in its normal sampling mode, and the precision test gas must pass through all filters, scrubbers, conditioners, and other components used during normal ambient sampling. The standards from which precision check test concentrations are obtained must be traceable to NIST-SRM. Those standards used for calibration or auditing may be used.

To perform a precision check, the instrument set up; sources of zero air and sample gas and procedures should conform to those described in Section 7.3 for analyzer's with no valve options or with an IZS valve option installed and Section 7.6 for analyzer's with Z/S options installed with the following exception:

- Connect the analyzer to a precision gas that has an SO₂ concentration between 0.08 and 0.10 ppm. If a precision check is made in conjunction with a zero/span check, it must be made prior to any zero or span adjustments.

Record this value. Information from the check procedure is used to assess the precision of the monitoring data; see 40 CFR 58 for procedures for calculating and reporting precision.

8.5. DYNAMIC MULTIPOINT SPAN CALIBRATION

Dynamic calibration involves introducing gas samples of known concentrations to an instrument in order to record the instruments performance at a predetermined sensitivity and to derive a calibration relationship. A minimum of three reference points and one zero point uniformly spaced covering 0 to 90 percent of the operating range are recommended to define this relationship.

The analyzer's recorded response is compared with the known concentration to derive the calibration relationship.

To perform a precision check, the instrument set up, sources of zero air and sample gas should conform to those described in Section 7.2.

Follow the procedures described in section 7.2 for calibrating the zero points.

For each mid point:

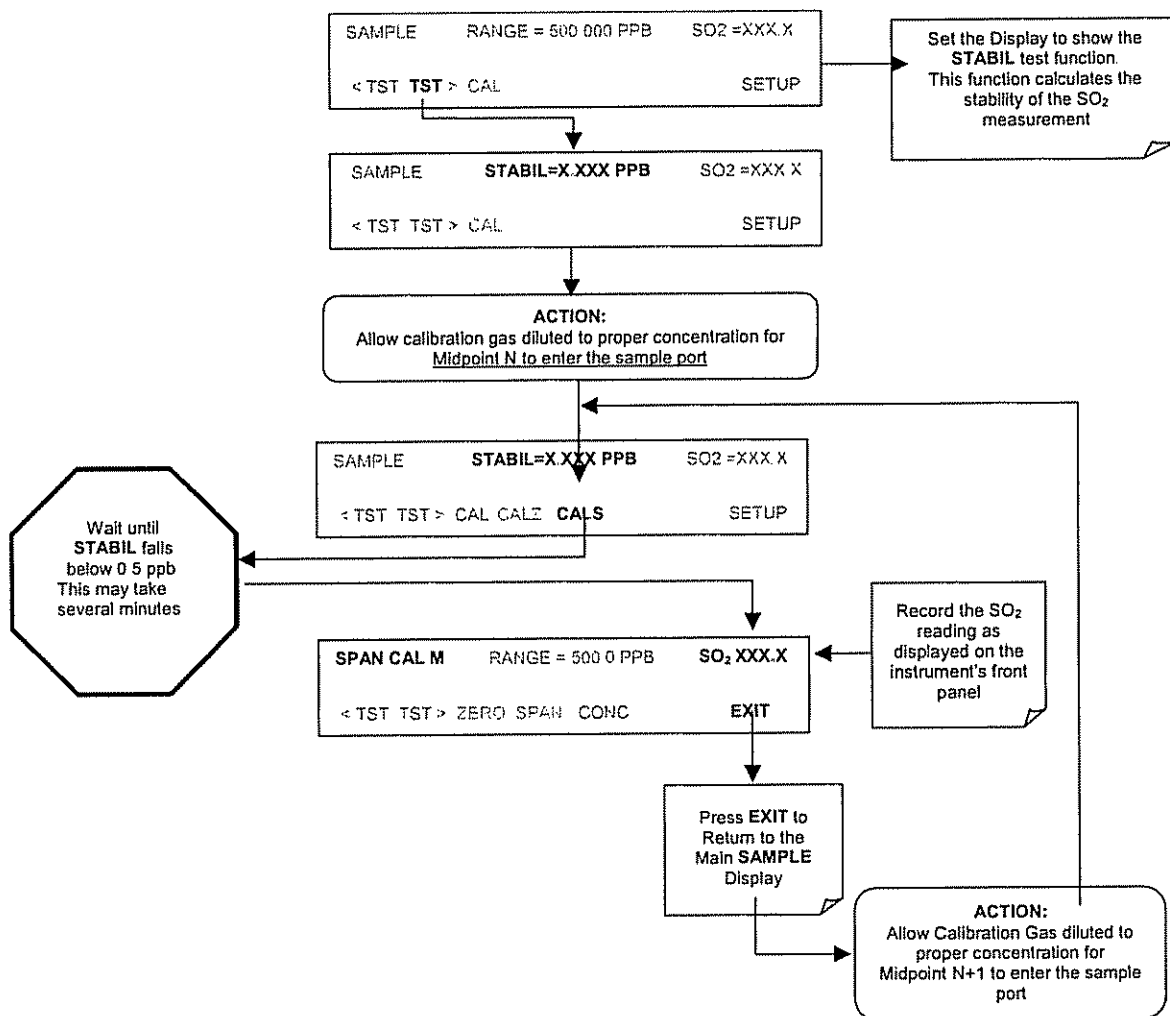

8.6. SPECIAL CALIBRATION REQUIREMENTS FOR DUAL RANGE OR AUTO RANGE

If Dual Range or Auto Range is selected, then it should be calibrated for both Range1 and Range2 separately.

For zero and span point calibration, follow the procedure described in Section 7.2. Repeat the procedure for both the **HIGH** and **LOW** Ranges

8.7. REFERENCES

1. Environmental Protection Agency, Title 40, Code of Federal Regulations, Part 50, Appendix A, Section 10.3.
2. Quality Assurance Handbook for Air Pollution Measurement Systems - Volume II, Ambient Air Specific Methods, EPA-600/4-77-027a, 1977.
3. Catalog of NBS Standard Reference Materials. NBS Special Publication 260, 1975-76 Edition. U.S. Department of Commerce, NBS. Washington, D.C. June 1975. (Tel: 301-975-6776 for ordering the catalog)
4. Quality Assurance Handbook for Air Pollution Measurement Systems - Volume I, Principles. EPA-600/9-76-005. March 1976.

User Notes:

9. INSTRUMENT MAINTENANCE

Predictive diagnostic functions including data acquisition, failure warnings and alarms built into the analyzer allow the user to determine when repairs are necessary without performing unnecessary, preventative maintenance procedures. There is, however, a minimal number of simple procedures that, when performed regularly, will ensure that the analyzer continues to operate accurately and reliably over its lifetime. Maintenance, repair and troubleshooting procedures are covered in Chapters 9 and 11 of this manual.

NOTE

A span and zero calibration check must be performed following some of the maintenance procedures listed below. Refer to Chapter 7.



CAUTION

Risk of electrical shock. Disconnect power before performing any operations that require entry into the interior of the analyzer.

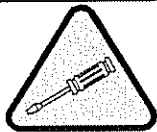

NOTE

The operations outlined in this chapter must be performed by qualified maintenance personnel only.

NOTE

The front panel of the analyzer is hinged at the bottom and may be opened to gain access to various components mounted on the panel itself or located near the front of the instrument (such as the particulate filter).

Two fasteners located in the upper right and left corners of the panel lock it shut (see Figure 3-10).

9.1. MAINTENANCE SCHEDULE

Table 9-1 is the recommended maintenance schedule for the 6400E. Please note that in certain environments with high levels of dust, humidity or pollutant levels some maintenance procedures may need to be performed more often than shown.

Table 9-1: 6400E Preventive Maintenance Schedule

ITEM	ACTION	FREQUENCY	CAL CHECK	MANUAL SECTION	DATE PERFORMED							
¹ Particulate filter	Change particle filter	Weekly	No	9.3.1								
Verify test functions	Review and evaluate	Weekly	No	9.2; Appendix C								
Zero/span check	Evaluate offset and slope	Weekly	--	7.3, 7.6, 7.9								
⁴ Zero/span calibration	Zero and span calibration	Every 3 months	--	7.2, 7.4, 7.5, 7.7, 7.8								
¹ External zero air scrubber (optional)	Exchange chemical	Every 3 months	No	9.3.3								
¹ Perform flow check	Check Flow	Every 6 Months	No	11.5.2								
Internal IZS Permeation Tube	Replace	Annually	YES	9.3.2								
Perform pneumatic leak check	Verify Leak Tight	Annually or after repairs involving pneumatics	Yes	11.5.1								
² Pump diaphragm	Replace	Annually	Yes	See diaphragm kit instructions								
Calibrate UV Lamp Output	Perform LAMP CAL	Prior to zero/span calibration or PMT hardware calibration	--	6.9.7 & 11.6.3.5								
PMT sensor hardware calibration	Low-level hardware calibration	On PMT/ preamp changes if $0.7 < \text{SLOPE}$ or $\text{SLOPE} > 1.3$	Yes	11.6.3.8								
¹ Sample chamber optics	Clean chamber, windows and filters	As necessary	Yes	11.6.3.2 & 11.6.3.3								
¹ Critical flow orifice & sintered filters	Replace	As necessary	Yes	9.3.4								

¹ These Items are required to maintain full warranty, all other items are strongly recommended.

² A pump rebuild kit is available from Teledyne Instruments Customer Service including all instructions and required parts (see Appendix B for part numbers).

9.2. PREDICTIVE DIAGNOSTICS

The analyzer's test functions can be used to predict failures by looking at trends in their values (see Table 9.2) and by comparing them values recorded for them at the factory and recorded on the *6400E Final Test and Validation Data Form* (TAI part number 04551) that was shipped with your analyzer.

A convenient way to record and track changes to these parameters is the internal data acquisition system (iDAS). Also, APICOM control software can be used to download and record these data for review even from remote locations (see Section 6.12.2.8. describes APICOM).

Table 9-2: Predictive Uses for Test Functions

TEST FUNCTION	iDAS FUNCTION	CONDITION	BEHAVIOR		INTERPRETATION
			EXPECTED	ACTUAL	
PRES	SMPPRS	sample gas	Constant within atmospheric changes	Fluctuating	<ul style="list-style-type: none"> Developing leak in pneumatic system
				Slowly increasing	<ul style="list-style-type: none"> Flow path is clogging up. <ul style="list-style-type: none"> - Check critical flow orifice & sintered filter. - Replace particulate filter
				Slowly decreasing	<ul style="list-style-type: none"> Developing leak in pneumatic system to vacuum (developing valve failure)
DRK PMT	DRKPMT	PMT output when UV Lamp shutter closed	Constant within ± 20 of check-out value	Significantly increasing	<ul style="list-style-type: none"> PMT cooler failure Shutter Failure
SO ₂ Concentration	CONC1	At span with IZS option installed	Constant response from day to day	Decreasing over time	<ul style="list-style-type: none"> Change in instrument response Degradation of IZS permeation tube
		Standard configuration at span	stable for constant concentration	Decreasing over time	<ul style="list-style-type: none"> Drift of instrument response; UV Lamp output is excessively low.
SAMP FL	SMPFLW	Standard Operation	Stable	Slowly Decreasing	<ul style="list-style-type: none"> Flow path is clogging up. <ul style="list-style-type: none"> - Check critical flow orifice & sintered filter. - Replace particulate filter
				Fluctuating	<ul style="list-style-type: none"> Leak in gas flow path.
LAMP RATIO	LAMPR	Standard Operation	Stable and near 100%	Fluctuating or Slowly increasing	<ul style="list-style-type: none"> UV detector wearing out UV source Filter developing pin holes
				Slowly decreasing	<ul style="list-style-type: none"> UV detector wearing out Opaque oxides building up on UV source Filter UV lamp aging

9.3. MAINTENANCE PROCEDURES

The following procedures need to be performed regularly as part of the standard maintenance of the Model 6400E.

9.3.1. CHANGING THE SAMPLE PARTICULATE FILTER

The particulate filter should be inspected often for signs of plugging or excess dirt. It should be replaced according to the service interval in Table 9-1 even without obvious signs of dirt. Filters with 1 and 5 μm pore size can clog up while retaining a clean look. We recommend handling the filter and the wetted surfaces of the filter housing with gloves and tweezers. Do not touch any part of the housing, filter element, PTFE retaining ring, glass cover and the O-ring with bare hands.

To change the filter according to the service interval in Table 9-1:

1. Turn OFF the analyzer to prevent drawing debris into the sample line.
2. Open the 6400E's hinged front panel and unscrew the knurled retaining ring of the filter assembly.

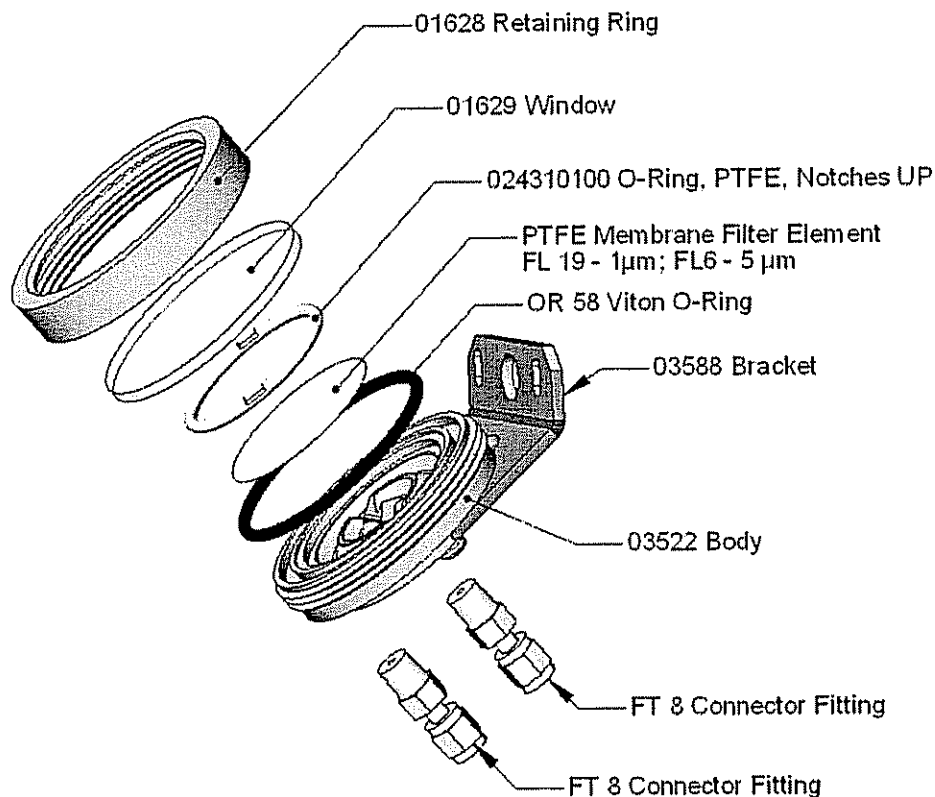

Figure 9-1: Sample Particulate Filter Assembly

3. Carefully remove the retaining ring, glass window, PTFE O-ring and filter element.
4. Replace the filter element, carefully centering it in the bottom of the holder.

5. Re-install the PTFE O-ring with the notches facing up, the glass cover, then screw on the hold-down ring and hand-tighten the assembly. Inspect the (visible) seal between the edge of the glass window and the O-ring to assure proper gas tightness.
6. Re-start the analyzer.

9.3.2. CHANGING THE IZS PERMEATION TUBE

1. Turn off the analyzer, unplug the power cord and remove the cover.
2. Locate the IZS oven in the rear left of the analyzer.
3. Remove the top layer of insulation if necessary.
4. Unscrew the black aluminum cover of the IZS oven (3 screws) using a medium Phillips-head screw driver. Leave the fittings and tubing connected to the cover.
5. Remove the old permeation tube if necessary and replace it with the new tube. Make sure that the tube is placed into the larger of two holes and that the open permeation end of the tube (teflon) is facing up.
6. Re-attach the cover with three screws and make sure that the sealing O-ring is properly in place and that the three screws are tightened evenly.
7. Replace the analyzer cover, plug the power cord back in and turn on the analyzer.
8. Carry out an IZS span check to see if the new permeation device works properly. The permeation rate may need several days to stabilize.



WARNING

Do not leave instrument turned off for more than 8 hours without removing the permeation tube. Do not ship the instrument without removing the permeation tube. The tube continues to emit gas, even at room temperature and will contaminate the entire instrument.

9.3.3. CHANGING THE EXTERNAL ZERO AIR SCRUBBER

The chemicals in the external scrubber need to be replaced periodically according to Table 9-1 or as needed. This procedure can be carried out while the instrument is running. Make sure that the analyzer is not in either the ZERO or SPAN calibration modes.

1. Locate the scrubber on the outside rear panel.
2. Remove the old scrubber by disconnecting the 1/4" plastic tubing from the particle filter using 9/16" and 1/2" wrenches.
3. Remove the particle filter from the cartridge using 9/16" wrenches.
4. Unscrew the top of the scrubber canister and discard charcoal contents. Make sure to abide by local laws about discarding these chemicals. The rebuild kit (listed in Appendix B) comes with a Material and Safety Data Sheet, which contains more information on these chemicals.

5. Refill the scrubber with charcoal at the bottom.
6. Tighten the cap on the scrubber - hand-tight only.
7. Replace the DFU filter, if required, with a new unit and discard the old.
8. Replace the scrubber assembly into its clips on the rear panel.
9. Reconnect the plastic tubing to the fitting of the particle filter.
10. Adjust the scrubber cartridge such that it does not protrude above or below the analyzer in case the instrument is mounted in a rack. If necessary, squeeze the clips for a tighter grip on the cartridge.

9.3.4. CHANGING CRITICAL FLOW ORIFICES

A critical flow orifice, located on the exhaust manifold maintains the proper flow rate of gas through the 6400E analyzer. Refer to section 10.3.2.1 for a detailed description of its functionality and location. Despite the fact this device is protected by sintered stainless steel filters, it can, on occasion, clog, particularly if the instrument is operated without a sample filter or in an environment with very fine, sub-micron particle-size dust.

1. Turn off power to the instrument and vacuum pump.
2. Locate the exhaust manifold (see Figure 3-9)
3. Disconnect the pneumatic line.
4. Unscrew the NPT fitting.

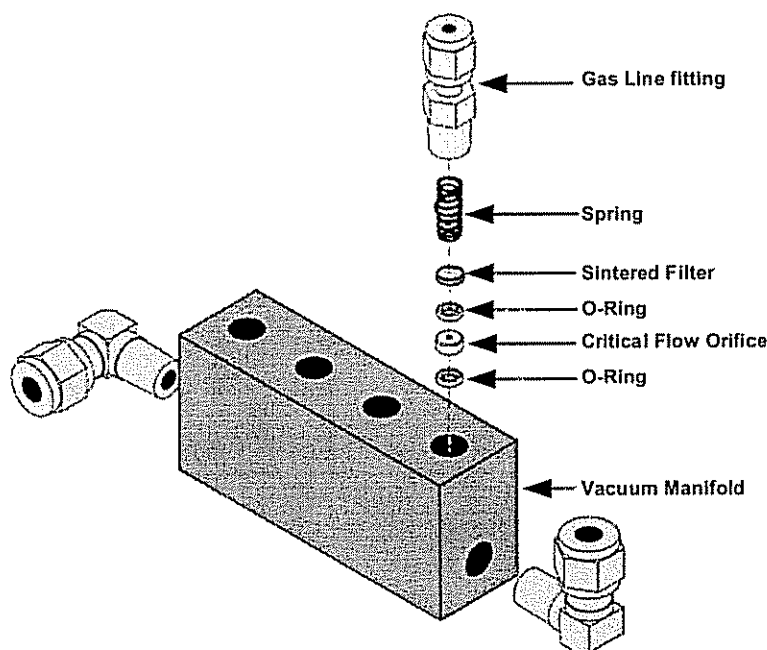

Figure 9-2: Critical Flow Orifice Assembly

5. Take out the components of the assembly: a spring, a sintered filter, two O-rings and the orifice.

- You may need to use a scribe or pressure from the vacuum port to get the parts out of the manifold.
6. Discard the two O-rings and the sintered filter.
 7. Replace the critical flow orifice.
 8. Let the part dry.
 9. Re-assemble the parts as shown in Figure 9-2 using a new filter and o-rings
 10. Reinstall the NPT fitting and connect all tubing.
 11. Power up the analyzer and allow it to warm up for 60 minutes.
 12. Perform a leak check (See Section 11.5.1)

9.3.5. CHECKING FOR LIGHT LEAKS

When re-assembled after maintenance of repair or when operated improperly, the 6400E can develop small leaks around the PMT, which let stray light from the analyzer surrounding into the PMT housing. To find such light leaks, follow the below procedures.



CAUTION

This procedure can only be carried out with the analyzer running and its cover removed. This procedure should only be carried out by qualified personnel.

1. Scroll the TEST functions to PMT.
2. Supply zero gas to the analyzer.
3. With the instrument still running, carefully remove the analyzer cover. Take extra care not to touch any of the inside wiring with the metal cover or your body. Do not drop screws or tools into a running analyzer!
4. Shine a powerful flashlight or portable incandescent light at the inlet and outlet fitting and at all of the joints of the sample chamber as well as around the PMT housing. The PMT value should not respond to the light, the PMT signal should remain steady within its usually noise.
5. If there is a PMT response to the external light, symmetrically tighten the sample chamber mounting screws or replace the 1/4" vacuum tubing with new, black PTFE tubing (this tubing will fade with time and become transparent). Often, light leaks are also caused by O-rings being left out of the assembly.
6. Carefully replace the analyzer cover.
7. If tubing was changed, carry out a leak check (see Section 11.5.1).

USER NOTES:

10. THEORY OF OPERATION

The 6400E UV Fluorescence SO₂ Analyzer is a microprocessor controlled analyzer that determines the concentration of sulfur dioxide (SO₂), in a sample gas drawn through the instrument. It requires that sample and calibration gases be supplied at ambient atmospheric pressure in order to establish a constant gas flow through the sample chamber where the sample gas is exposed to ultraviolet light causing the SO₂ become excited (SO₂*). As these SO₂* molecules decay into SO₂ they fluoresce. The instrument measures the amount of fluorescence to determine the amount of SO₂ present in the sample gas.

Calibration of the instrument is performed in software and usually does not require physical adjustments to the instrument. During calibration, the microprocessor measures the sensor output signal when gases with known amounts of SO₂ at various concentrations are supplied and stores these measurements in memory. The microprocessor uses these calibration values along with other performance parameters such as the PMT dark offset, UV lamp ratio and the amount of stray light present and measurements of the temperature and pressure of the sample gas to compute the final SO₂ concentration.

This concentration value and the original information from which it was calculated are stored in the unit's internal data acquisition system and reported to the user through a vacuum fluorescent display or as electronic data via several communication ports.

This concentration value and the original information from which it was calculated are stored in the unit's internal data acquisition system (iDAS Section 6.11) and reported to the user through a vacuum fluorescent display or several communication ports.

10.1. MEASUREMENT PRINCIPLE

10.1.1. SO₂ ULTRAVIOLET FLUORESCENCE

The physical principle upon which the 6400E's measurement method is based is the fluorescence that occurs when sulfur dioxide (SO₂) is excited by ultraviolet light with wavelengths in the range of 190 nm-230 nm. This reaction is a two-step process.

The first stage (Equation 10-1) occurs when SO₂ molecules are struck by photons of the appropriate ultraviolet wavelength. In the case of the Model 6400E, a band pass filter between the source of the UV light and the affected gas limits the wavelength of the light to approximately 214 nm. The SO₂ molecules absorbs some of energy from the UV light causing one of the electrons of each of the affected molecules to move to a higher energy orbital state.

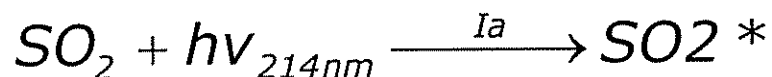

(Equation 10-1)

The amount SO_2 converted to excited SO_2^* in the sample chamber is dependent on the average intensity of the UV light (I_a) and not its peak intensity because the intensity of UV light is not constant in every part of the sample chamber. Some of the photons are absorbed by the SO_2 as the light travels through the sample gas.

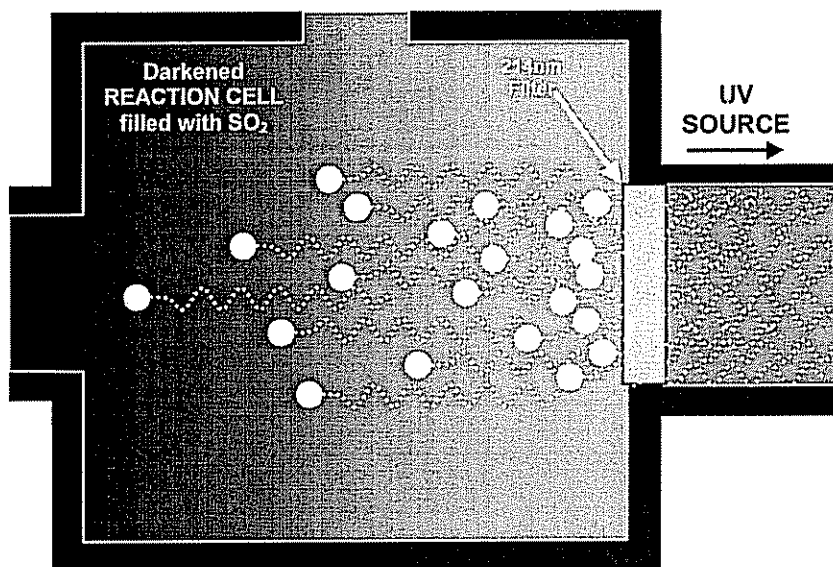

Figure 10-1: UV Absorption

The equation for defining the average intensity of the UV light (I_a) is:

$$I_a = I_0 [1 - \exp(-ax(\text{SO}_2))]$$

(Equation 10-2)

Where:

- I_0 = Intensity of the excitation UV light.
- a = The absorption coefficient of SO_2 (a constant).
- SO_2 = Concentration of SO_2 in the sample chamber.
- x = The distance between the UV source and the SO_2 molecule(s) being affected (path length).

The second stage of this reaction occurs after the SO_2 reaches its excited state (SO_2^*). Because the system will seek the lowest available stable energy state, the SO_2^* molecule quickly returns to its ground state (Equation 10-3) by giving off the excess energy in the form of a photon ($h\nu$). The wavelength of this fluoresced light is also in the ultraviolet band but at a longer (lower energy) wavelength centered at 330nm.

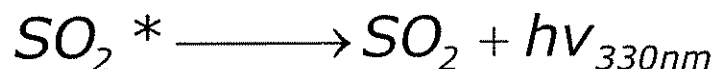

(Equation 10-3)

The amount of detectable UV given off by the decay of the SO_2^* is affected the rate at which this reaction occurs (k).

$$F = k(SO_2^*)$$

(Equation 10-4)

Where:

- F = the amount of fluorescent light given off.
 k = The rate at which the SO_2^* decays into SO_2 .
 SO_2^* = Amount of excited SO_2 in the sample chamber.

So:

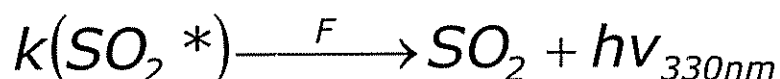

(Equation 10-5)

Finally, the function (k) is affected by the temperature of the gas. The warmer the gas, the faster the individual molecules decay back into their ground state and the more photons of UV light are given off per unit of time.

In summary, given that the absorption rate of SO_2 (a) is constant, the amount of fluorescence (F) is a result of :

- The amount of excited SO_2^* created which is affected by the variable factors from equation 10-2 above: concentration of SO_2 ; intensity of UV light (I_0); path length of the UV light (x) and;
- The amount of fluorescent light created which is affected by the variable factors from equation 10-5: the amount of SO_2^* present and the rate of decay (k) which changes based on the temperature of the gas.

So, when the intensity of the light (I_0) is known; path length of excited light is short (x); the temperature of the gas is known and compensated for so that the rate of SO_2^* decay is constant (k); and; no interfering conditions are present (such as interfering gases or stray light); the amount of fluorescent light emitted (F) is directly related to the concentration of the SO_2 in the Sample Chamber.

The Model 6400E UV Fluorescence SO_2 Analyzer is specifically designed to create these circumstances.

- The light path is very short (x).
- A reference detector measures the intensity of the available excitation UV light and is used to remove effects of lamp drift (I_0).
- The temperature of the sample gas is measured and controlled via heaters attached to the sample chamber so that the rate of decay (k) is constant.
- A special hydrocarbon scrubber removes the most common interfering gases from the sample gas.
- And finally, the design of the sample chamber reduces the effects of stray light via its optical geometry and spectral filtering.

The net result is that any variation in UV fluorescence can be directly attributed to changes in the concentration of SO_2 in the sample gas.

10.2. THE UV LIGHT PATH

The optical design of the Model 6400E's sample chamber optimizes the fluorescent reaction between SO_2 and UV Light (see Figure 10-2) and assure that only UV light resulting from the decay of SO_2^* into SO_2 is sensed by the instruments fluorescence detector.

UV radiation is generated by a lamp specifically designed to produce a maximum amount of light of the wavelength needed to excite SO_2 into SO_2^* (330 nm) and a special reference detector circuit constantly measures lamp intensity (see Equation 10-2). A Photo Multiplier Tube (PMT) detects the UV given off by the SO_2^* decay (214 nm) and outputs an analog signal. Several focusing lenses and optical filters make sure that both detectors are exposed to an optimum amount of only the right wavelengths of UV. To further assure that the PMT only detects light given off by decaying SO_2^* the pathway of the excitation UV and field of view of the PMT are perpendicular to each other and the inside surfaces of the sample chamber are coated with a layer of black Teflon[®] that absorbs stray light.

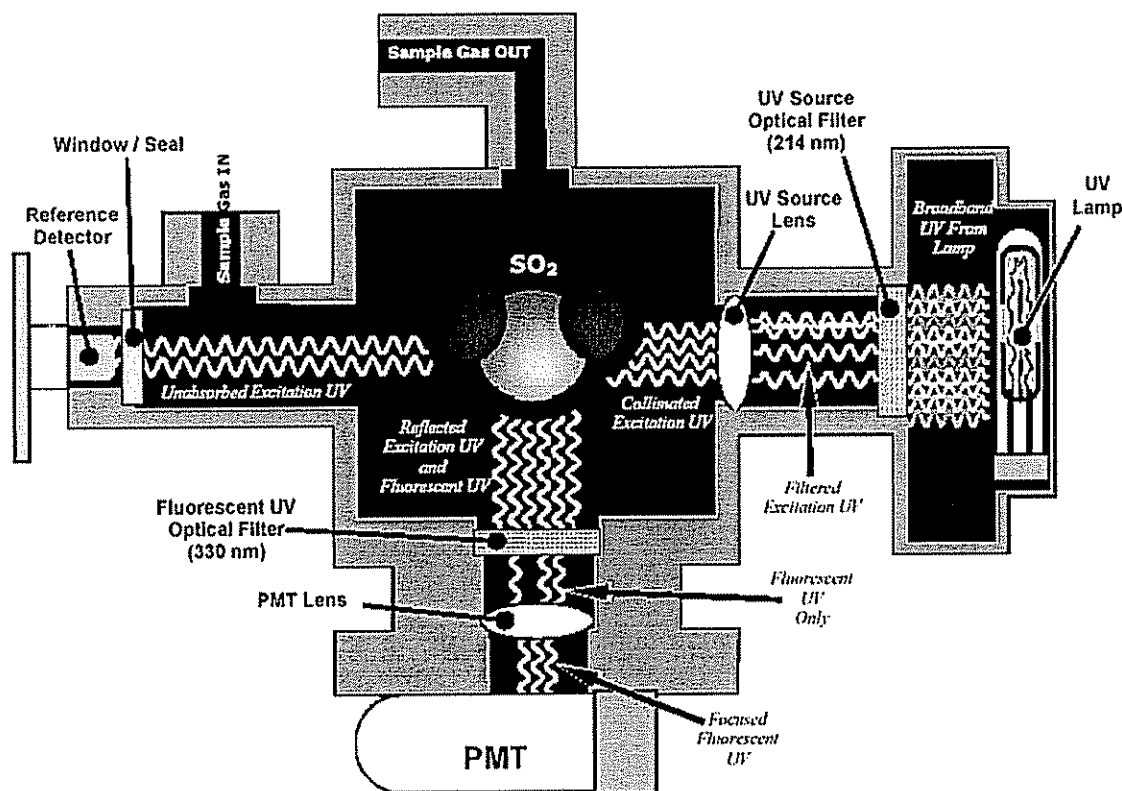

Figure 10-2: UV Light Path

10.2.1. UV SOURCE LAMP

The source of excitation UV light for the Model 6400E is a low pressure zinc-vapor lamp. An AC voltage heats up and vaporizes zinc contained in the lamp element creating a light-producing plasma arc. Zinc-vapor lamps are preferred over the more common mercury-vapor lamps for this

application because they produce very strong emission levels at the wavelength required to convert SO_2 to SO_2^* , 213.9 nm (see Figure 10-4).

The lamp used in the Model 6400E is constructed with a vacuum jacket surrounding a double-bore lamp element (see Figure 10-3). The vacuum jacket isolates the plasma arc from most external temperature fluctuations. The jacket also contains the thermal energy created by the lamps operation thereby helping the lamp heat up to and maintain proper vaporization temperature. Light is emitted through a 20 mm x 5 mm portal.

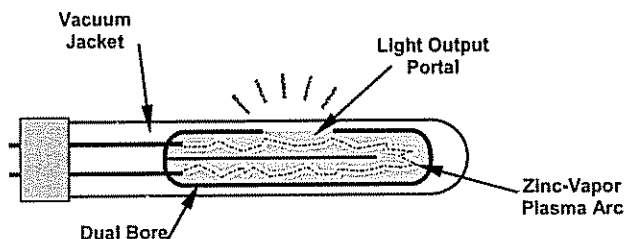

Figure 10-3: Source UV Lamp Construction

10.2.2. THE REFERENCE DETECTOR

A vacuum diode, UV detector that converts UV light to a DC current is used to measure the intensity of the excitation UV source lamp. It's location, directly across from the source lamp at the back of a narrow tube-shaped light trap, places it directly in the path of the excitation UV light. A window transparent to UV light provides an air-proof seal that prevents ambient gas from contaminating the sample chamber. The shape of the light trap and the fact that the detector is blind to wavelengths other than UV no extra optical filtering is needed.

10.2.3. THE PMT

The amount of fluoresced UV produced in the sample chamber is much less than the intensity of excitation UV source lamp (see Figure 10-4). Therefore a much more sensitive device is needed to detect this light with enough resolution to be meaningful. The Model 6400E uses a Photo Multiplier Tube or PMT for this purpose.

A PMT is typically a vacuum tube containing a variety of specially designed electrodes. Photons enter the PMT and strike a negatively charged photo cathode causing it to emit electrons. These electrons are accelerated by a high voltage applied across a series of special electrodes called dynodes that multiply the amount of electrons until a useable current signal is generated. This current increases or decreases with the amount of detected light (see Section 10.4.3 for more details regarding the electronic operation of the PMT).

10.2.4. UV LAMP SHUTTER & PMT OFFSET

Inherent in the operation of both the reference detector and the PMT are a minor electronic offsets. The degree of offset differs from detector to detector and from PMT to PMT and can change over time as these components age.

To account for these offsets the 6400E includes a shutter, located between the UV Lamp and the source filter, that periodically cuts off the UV light from the sample chamber. This happens every 30 minutes. The analyzer records the outputs of both the reference detector and the PMT during this dark period and factors them into the SO_2 concentration calculation.

- The reference detector offset is stored as and viewable via the front panel as the test function **DRK LMP**.
- The PMT offset is stored as and viewable via the front panel as the test function **DRK PMT**

10.2.5. OPTICAL FILTERS

The Model 6400E analyzer uses two stages of optical filters to enhance performance. The first stage conditions the UV light used to excite the SO_2 by removing frequencies of light that are not needed to produce SO_2^* . The second stage protects the PMT detector from reacting to light not produced by the SO_2^* returning to its ground state.

UV Source Optical Filter

Zinc-vapor lamps output light at other wavelengths beside the 214nm required for the $\text{SO}_2 \rightarrow \text{SO}_2^*$ transformation including a relatively bright light of the same wavelength at which SO_2^* fluoresces as it returns to its SO_2 ground state (330 nm). In fact, the intensity of the light emitted by the UV lamp at 330nm is so bright, nearly five orders of magnitude brighter than that resulting from the SO_2^* decay, it would drown out the SO_2^* fluorescence.

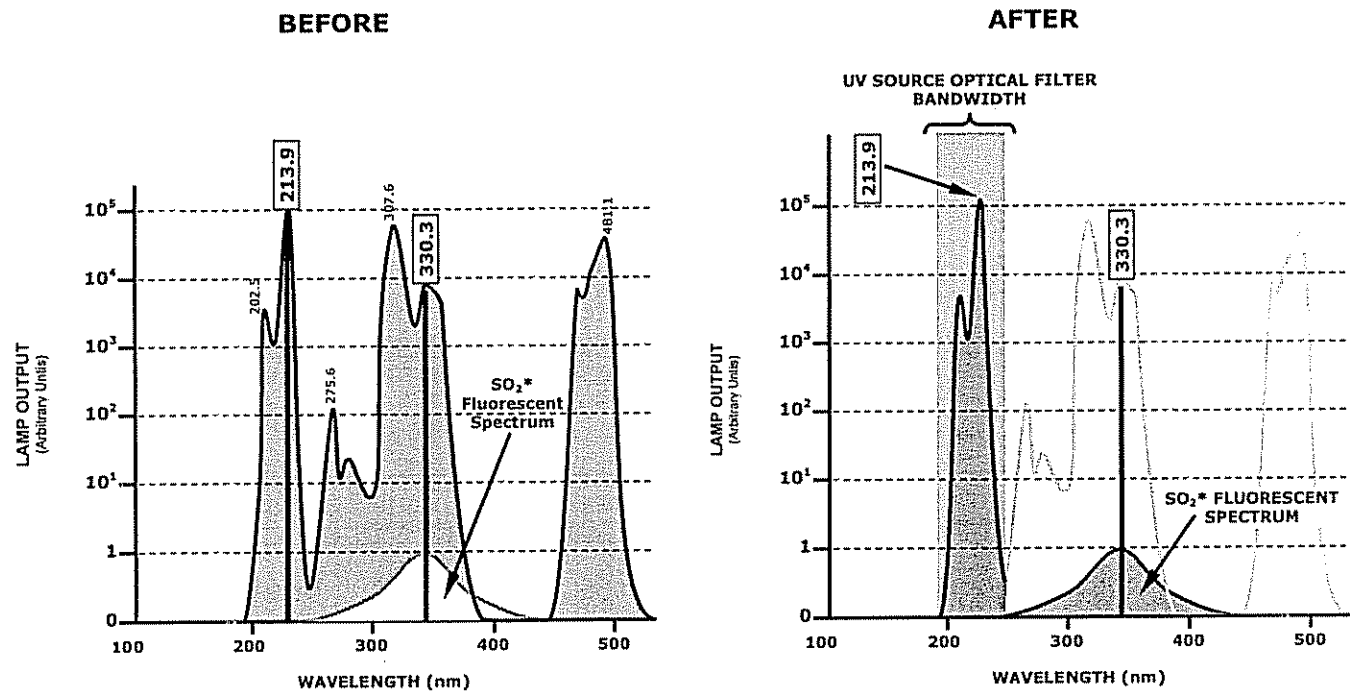

Figure 10-4: Excitation Lamp UV Spectrum Before/After Filtration

To solve this problem, the light emitted by the excitation UV lamp passes through a bandpass filter that screens out photons with wavelengths outside the spectrum required to excite SO_2 into SO_2^* . (see Figure 10-4).

PMT Optical Filter

The PMT used in the Model 6400E reacts to a wide spectrum of light which includes much of the visible spectrum and most of the UV spectrum. Even though the 214 nm light used to excite the SO_2 is focused away from the PMT, some of it scatters in the direction of the PMT as it interacts

with the sample gas. A second optical bandpass filter placed between the sample chamber (see Figure 10-2) and the PMT strips away light outside of the fluorescence spectrum of decaying SO_2^* (see Figure 10-5) including reflected UV from the source lamp and other stray light.

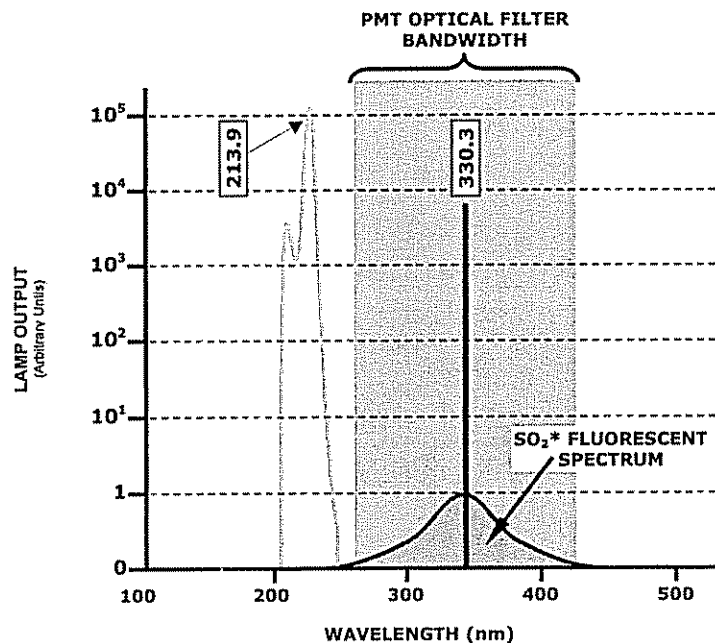

Figure 10-5: PMT Optical Filter Bandwidth

10.2.6. OPTICAL LENSES

Two optical lenses are used to focus and optimize the path of light through the sample chamber.

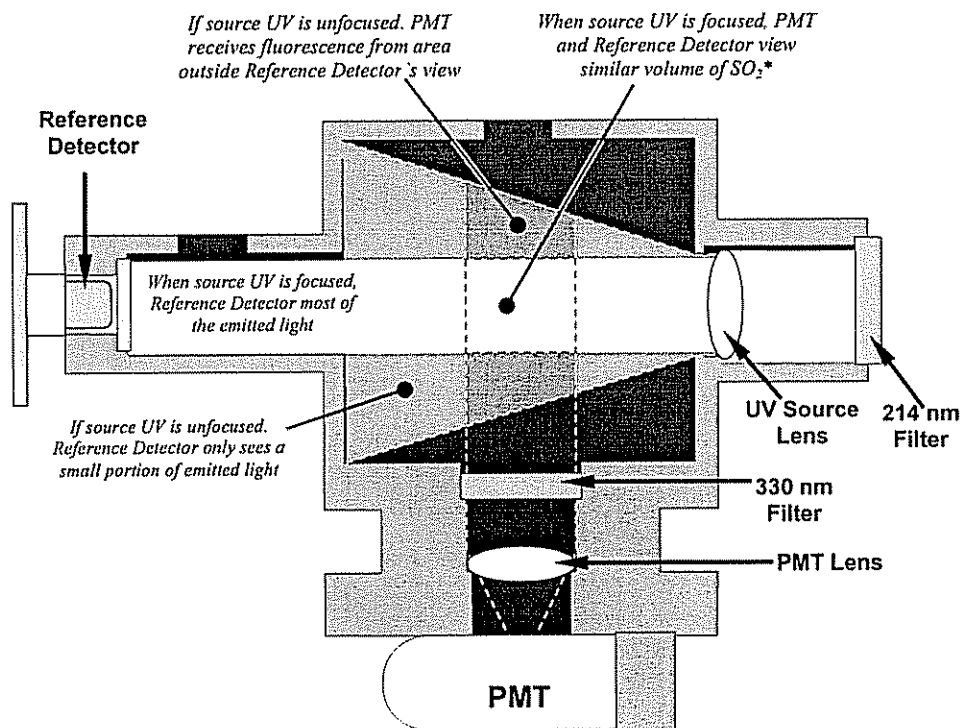

Figure 10-6: Effects of Focusing Source UV in Sample Chamber

A lens located between PMT and the sample chamber collects as much of the fluoresced UV created there as possible and focuses it on the most sensitive part of the PMT's photo cathode.

Another lens located between the excitation UV source lamp and the sample chamber collimates the light emitted by the lamp into a steady, circular beam and focuses that beam directly onto the reference detector. This allows the reference detector to accurately measure the effective intensity of the excitation UV by:

Eliminating the effect of flickering inherent in the plasma arc that generates the light.

Making sure that all of the light emitted by the source lamp, passed though the 214 nm filter and not absorbed by the SO₂ reaches the reference detector. Conversely, this also makes sure that the volume of sample gas affected by the excitation beam is similar to the volume of fluorescing SO₂* being measured by the PMT, eliminating a possible source of measurement offset.

10.2.7. MEASUREMENT INTERFERENCES

It should be noted that the fluorescence method for detecting SO₂ is subject to interference from a number of sources. The 6400E has been successfully tested for its ability to reject interference from most of these sources.

10.2.7.1. Direct Interference

The most common source of interference is from other gases that fluoresce in a similar fashion to SO₂ when exposed to UV Light. The most significant of these is a class of hydrocarbons called poly-nuclear aromatics (PNA) of which xylene and naphthalene are two prominent examples. Nitrogen oxide fluoresces in the a spectral range near to SO₂. For critical applications where high levels of NO are expected an optional optical filter is available that improves the rejection of NO (contact customer service for more information).

The Model 6400E Analyzer has several methods for rejecting interference from these gasses.

A special scrubber (kicker) mechanism removes any PNA chemicals present in the sample gas before it the reach the sample chamber.

The exact wavelength of light needed to excite a specific non-SO₂ fluorescing gas is removed by the source UV optical filter.

The light given off by Nitrogen Oxide and many of the other fluorescing gases is outside of the bandwidth passed by the PMT optical filter.

10.2.7.2. UV Absorption by Ozone

Because ozone absorbs UV Light over a relatively broad spectrum it could cause a measurement offset by absorbing some of the UV given off by the decaying SO₂* in the sample chamber. The Model 6400E prevents this from occurring by having a very short light path between the area where the SO₂* fluorescence occurs and the PMT detector. Because the light path is so short, the amount of O₃ needed to cause a noticeable effect would be much higher than could be reasonably expected in any application for which this instrument is intended.

10.2.7.3. Dilution

Certain gases with higher viscosities can lower the flow rate through the critical flow orifice that controls the movement of sample gas through the analyzer reducing the amount of sample gas in the sample chamber and thus the amount of SO₂ available to react with the UV light. While this can be a significant problem for some analyzers, the design of the Model 6400E is very tolerant of variations in sample gas flow rate and therefore does not suffer from this type of interference.

10.2.7.4. Third Body Quenching

While the decay of SO₂* to SO₂ happens quickly, it is not instantaneous. Because it is not instantaneous it is possible for the extra energy possessed by the excited electron of the SO₂* molecule to be given off as kinetic energy during a collision with another molecule. This in effect heats the other molecule slightly and allows the excited electron to move into a lower energy orbit without emitting a photon.

The most significant interferents in this regard are nitrogen oxide (NO), carbon dioxide (CO₂), water vapor (H₂O) and molecular oxygen (O₂). In ambient applications the quenching effect of these gases is negligible. For stack applications where the concentrations of some or all of these may be very high, specific steps **MUST** be taken to remove them from the sample gas before it enters the analyzer.

10.2.7.5. Light Pollution

Because 6400E measures light as a means of calculating the amount of SO₂ present, obviously stray light can be a significant interfering factor. The Model 6400E removes this interference source in several ways.

- The sample chamber is designed to be completely light tight to light from sources other than the excitation UV source lamp.
- All pneumatic tubing leading into the sample chamber is completely opaque in order to prevent light from being piped into the chamber by the tubing walls.
- The optical filters discussed in section 10.2.5; remove UV with wavelengths extraneous to the excitation and decay of SO₂/SO₂*.
- Most importantly, during instrument calibration the difference between the value of the most recently recorded PMT offset (see Section 10.2.4) and the PMT output while measuring zero gas (calibration gas devoid of SO₂) is recorded as the test function **OFFSET**. This **OFFSET** value is used during the calculation of the SO₂ concentration.

Since this offset is assumed to be due to stray light present in the sample chamber is also multiplied by the **SLOPE** and recorded as the function **STR. LGT**. Both **OFFSET** & **STR. LGT** are viewable via the front panel (see Section 6.2.1)

10.3. PNEUMATIC OPERATION

Caution

It is important that the sample airflow system is leak-tight and not pressurized over ambient pressure. Regular leak checks should be performed on the analyzer as described in the maintenance schedule, Table 9-1 . Procedures for correctly performing leak checks can be found in Section 11.5.1.

Relative Pressure versus Absolute Pressure

In this manual vacuum readings are given in inches of mercury absolute pressure (in-Hg-A), i.e. indicate an absolute pressure referenced against zero (a perfect vacuum).

10.3.1. SAMPLE GAS FLOW

The Flow of gas through the 6400E UV Fluorescence SO₂ Analyzer is created by a small internal pump that pulls air through the instrument.

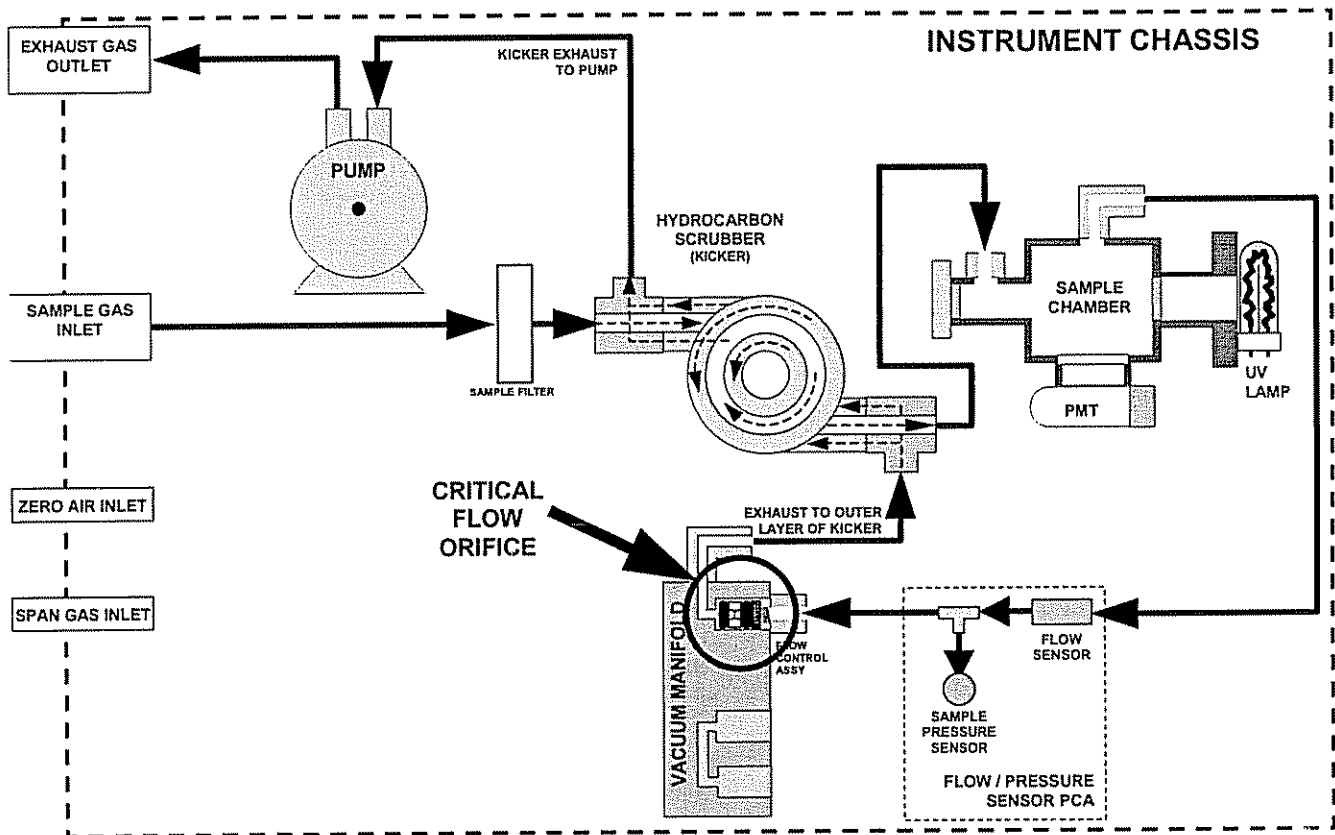

Figure 10-7: 6400E Gas Flow and Location of Critical Flow Orifice

10.3.2. FLOW RATE CONTROL

The Model 6400E uses a special flow control assembly located in the exhaust vacuum manifold (see Figure 10-7) to maintain a constant flow rate of the sample gas through the instrument. This assembly consists of:

- A critical flow orifice.
- Two o-rings: Located just before and after the critical flow orifice, the o-rings seal the gap between the walls of assembly housing and the critical flow orifice.
- A spring: Applies mechanical force needed to form the seal between the o-rings, the critical flow orifice and the assembly housing.

10.3.2.1. Critical Flow Orifice

The most important component of this flow control assembly is the critical flow orifice.

Critical flow orifices are a remarkably simple way to regulate stable gas flow rates. They operate without moving parts by taking advantage of the laws of fluid dynamics. By restricting the flow of gas through the orifice, a pressure differential is created. This pressure differential combined with the action of the analyzer's pump draws the gas through the orifice.

As the pressure on the downstream side of the orifice (the pump side) continues to drop, the speed that the gas flows through the orifice continues to rise. Once the ratio of upstream pressure to downstream pressure is greater than 2:1, the velocity of the gas through the orifice reaches the speed of sound. As long as that ratio stays at least 2:1 the gas flow rate is unaffected by any fluctuations, surges, or changes in downstream pressure because such variations only travel at the speed of sound themselves and are therefore cancelled out by the sonic shockwave at the downstream exit of the critical flow orifice.

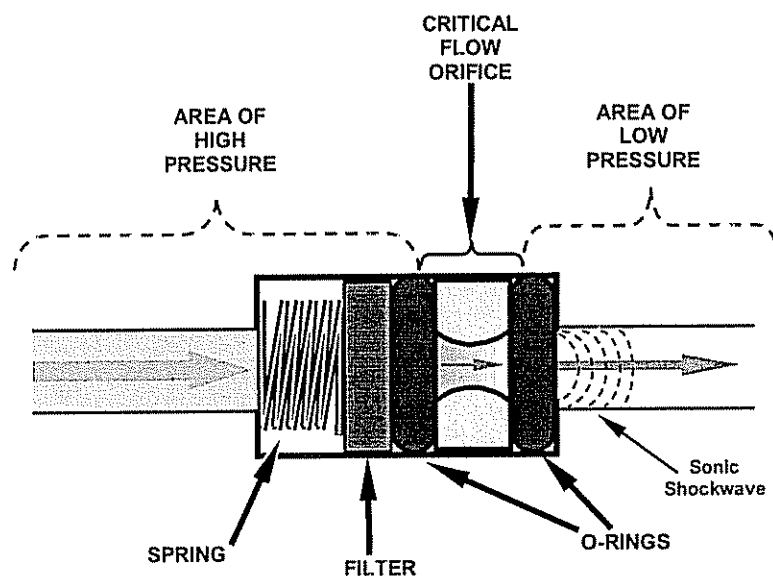

Figure 10-8: Flow Control Assembly & Critical Flow Orifice

The actual flow rate of gas through the orifice (volume of gas per unit of time), depends on the size and shape of the aperture in the orifice. The larger the hole, the more gas molecules, moving

at the speed of sound, pass through the orifice. Because the flow rate of gas through the orifice is only related to the minimum 2:1 pressure differential and not absolute pressure the flow rate of the gas is also unaffected by degradations in pump efficiency due to age.

The critical flow orifice used in the Model 6400E is designed to provide a flow rate of 650 cm³/min.

10.3.3. SAMPLE PARTICULATE FILTER

To remove particles in the sample gas, the analyzer is equipped with a Teflon membrane filter of 47 mm diameter (also referred to as the sample filter) with a 1 µm pore size. The filter is accessible through the front panel, which folds down, and should be changed according to the suggested maintenance schedule in Table 9-1.

10.3.4. HYDROCARBON SCRUBBER (*Kicker*)

It is very important to make sure the air supplied sample chamber is clear of hydrocarbons. To accomplish this task the 6400E uses a single tube permeation scrubber. The scrubber consists of a single tube of a specialized plastic that absorbs hydrocarbons very well. This tube is located within outer flexible plastic tube shell. As gas flows through the inner tube, hydrocarbons are absorbed into the membrane walls, and transported through the membrane wall and into the hydrocarbon free, purge gas flowing through the outer tube. This process is driven by the hydrocarbon concentration gradient between the inner and outer of the tubes.

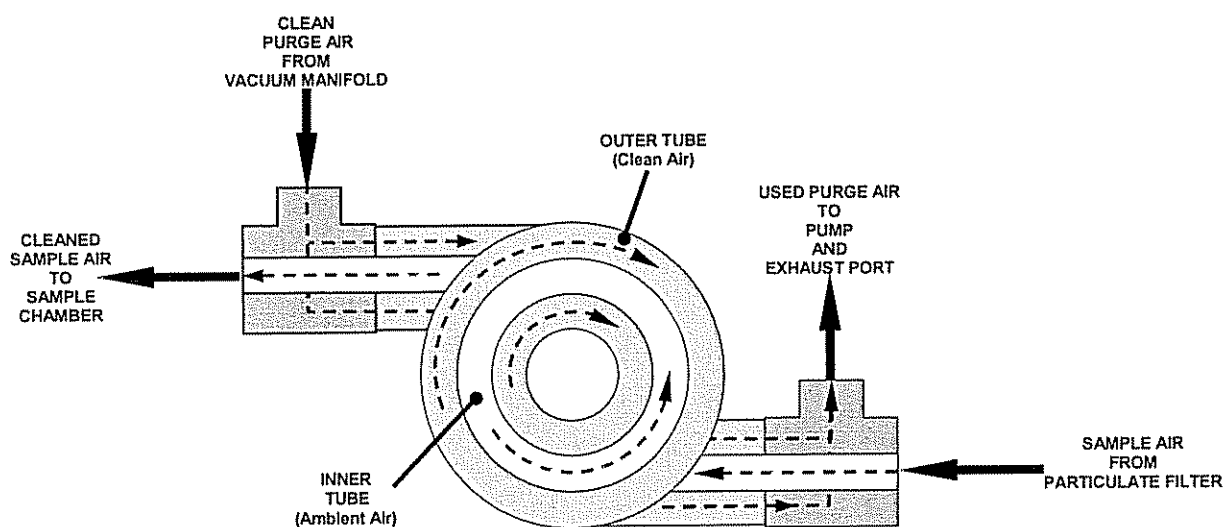

Figure 10-9: 6400E Hydrocarbon Scrubber (Kicker)

In the 6400E some of the cleaned air from the inner tube is returned to be used as the purge gas in the outer tube (see Figure 10-9). This means that when the analyzer is first started, the concentration gradient between the inner and outer tubes is not very large and the scrubber's efficiency is relatively low. When the instrument is turned on after having been off for more than 30 minutes, it takes a certain amount of time for the gradient to become large enough for the scrubber to adequately remove hydrocarbons from the sample air.

10.3.5. PNEUMATIC SENSORS

The 6400E uses two pneumatic sensors to verify gas streams. These sensors are located on a printed circuit assembly, called the pneumatic pressure/flow sensor board.

10.3.5.1. Sample Pressure Sensor

An absolute pressure transducer plumbed to the input of the analyzer's sample chamber is used to measure the pressure of the sample gas before it enters the chamber. This upstream used to validate the critical flow condition (2:1 pressure ratio) through the instrument's critical flow orifice (see Section 10.3.2). Also, if the temperature/pressure compensation (TPC) feature is turned on (see Section 10.7.3), the output of this sensor is also used to supply pressure data for that calculation.

The actual pressure measurement is viewable through the analyzer's front panel display as the test function **PRESS**.

10.3.5.2. Sample Flow Sensor

A thermal-mass flow sensor is used to measure the sample flow through the analyzer. This sensor is also mounted on the pneumatic pressure/flow sensor board upstream of the sample chamber. The flow rate is monitored by the CRT which issues a warning message (**SAMP FLOW WARN**) if the flow rate is too high or too low.

The flow rate of the sample gas is viewable via the front panel as the **SAMP FL** test function.

10.4. ELECTRONIC OPERATION

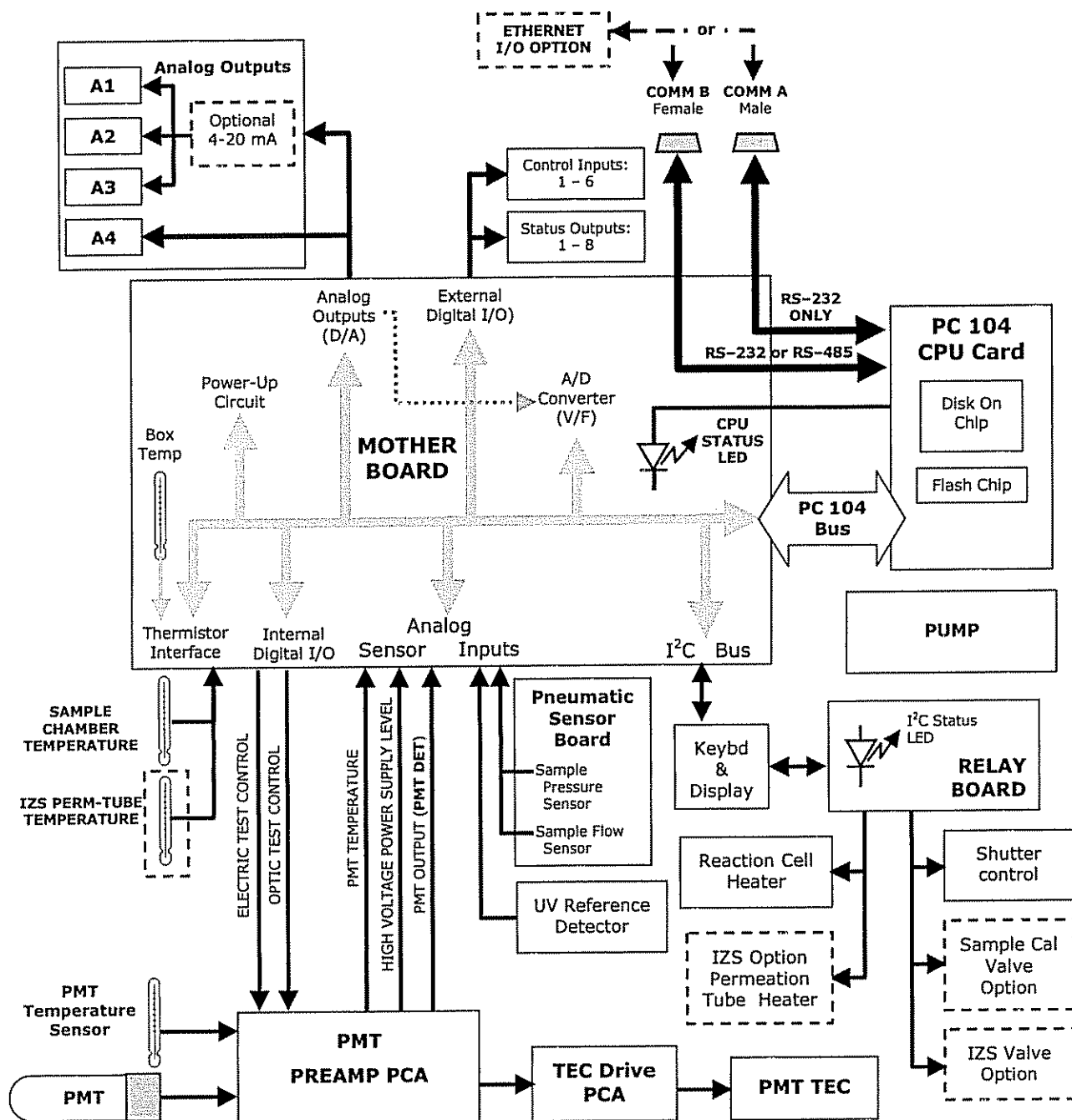

Figure 10-10: 6400E Electronic Block Diagram

The core of the analyzer is a microcomputer that controls various internal processes, interprets data, makes calculations, and reports results using specialized firmware developed by TAI. It communicates with the user as well as receives data from and issues commands to a variety of peripheral devices through a separate printed circuit assembly to which the CPU is mounted: the motherboard.

The motherboard is directly mounted to the rear panel and collects data, performs signal conditioning duties and routs incoming and outgoing signals between the CPU and the analyzer's other major components.

Concentration data of the 6400E are generated by the photo multiplier tube (PMT), which produces an analog current signal corresponding to the brightness of the fluorescence reaction in the sample chamber. This current signal is amplified to a DC voltage signal (front panel test parameter **PMT**) by a PMT preamplifier printed circuit assembly (located on top of the sensor housing). **PMT** is converted to digital data by a bi-polar, analog-to-digital converter, located on the motherboard.

In addition to the PMT signal, a variety of sensors report the physical and operational status of the analyzer's major components, again through the signal processing capabilities of the motherboard. These status reports are used as data for the SO₂ concentration calculation (e.g. pressure and temperature reading used by the temperature/pressure compensation feature) and as trigger events for certain warning messages and control commands issued by the CPU. They are stored in the CPU's memory and, in most cases, can be viewed through the front panel display.

The CPU communicates with the user and the outside world in a variety of ways:

- Through the analyzer's keyboard and vacuum fluorescent display over a clocked, digital, serial I/O bus using the I²C protocol (pronounced "I-squared-C");
- RS 232 & RS485 serial I/O channels;
- Various analog voltage and current outputs and
- Several digital I/O channels.

Finally, the CPU issues commands (also over the I²C bus) to a series of relays and switches located on a separate printed circuit assembly, the relay board (located in the rear of the chassis on its own mounting bracket) to control the function of key electromechanical devices such as heaters that keep the sample chamber at a steady temperature and, when installed, the zero/span and internal zero/span valve sets and heaters.

10.4.1. CPU

The CPU is a low power (5 VDC, 0.8A max), high performance, 386-based microcomputer running the DR-DOS operating system. Its operation and assembly conform to the PC-104 specification, version 2.3 for embedded PC and PC/AT applications. It has 2 MB of DRAM memory on board and operates at 40 MHz clock rate over an internal, 32-bit data and address bus. Chip to chip data handling is performed by two 4-channel direct memory access (DMA) devices over data busses of either 8-bit or 16-bit bandwidth. The CPU supports both RS-232 and RS-485 serial protocols. Figure 10-11 shows the CPU.

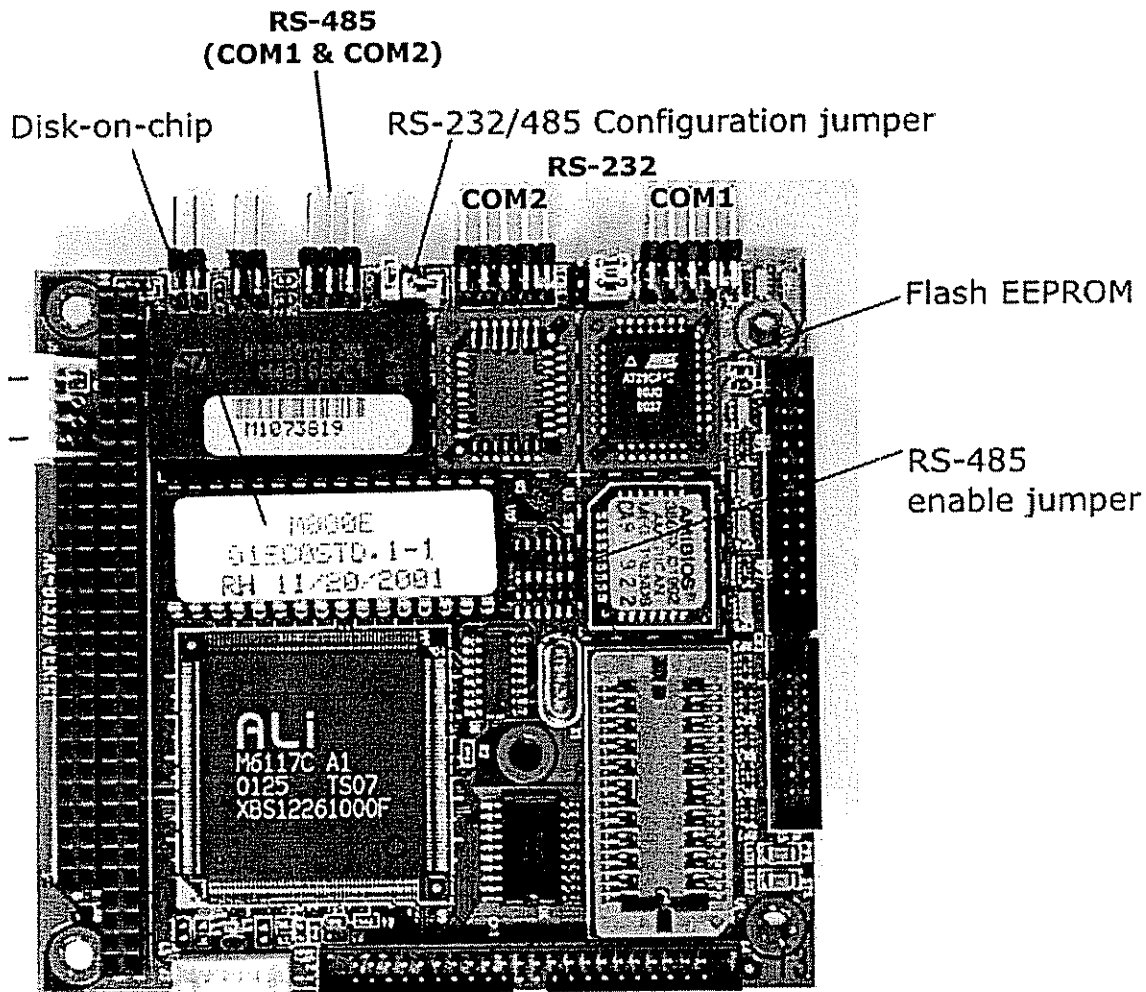

Figure 10-11: 6400E CPU Board

The CPU includes two types of non-volatile data storage, one disk-on-chip and one or two flash chips.

10.4.1.1. Disk On Chip

While technically an EEPROM, the disk-on-chip (DOC) appears to the CPU as, behaves as, and performs the same function in the system as an 8 mb disk drive. It is used to store the computer's operating system, the TAI firmware, and most of the operational data generated by the analyzer's internal data acquisition system (iDAS - Sections 10.7.4 and 6.11).

10.4.1.2. Flash Chip

This non-volatile memory includes 64 kb of space. The 6400E CPU board can accommodate up to two EEPROM flash chips. The 6400E standard configuration is one chip with 64 kb of storage capacity, which is used to store a backup of the analyzer configuration as created during final checkout at the factory. Separating these data onto a less frequently accessed chip significantly decreases the chance of those key data to get corrupted.

In the unlikely event that the flash chip should fail, the analyzer will continue to operate with just the DOC. However, all configuration information will be lost, requiring the unit to be recalibrated.

10.4.2. SENSOR MODULE

Electronically, the 6400E sensor module is a group of components that: create the UV light that initiates the fluorescence reaction between SO_2 and O_3 ; sense the intensity of that fluorescence and generate various electronic signals needed by the analyzer to determine the SO_2 concentration of the sample gas (see Section 10.1) and sense and control key environmental conditions such as the temperature of the sample gas and the PMT.

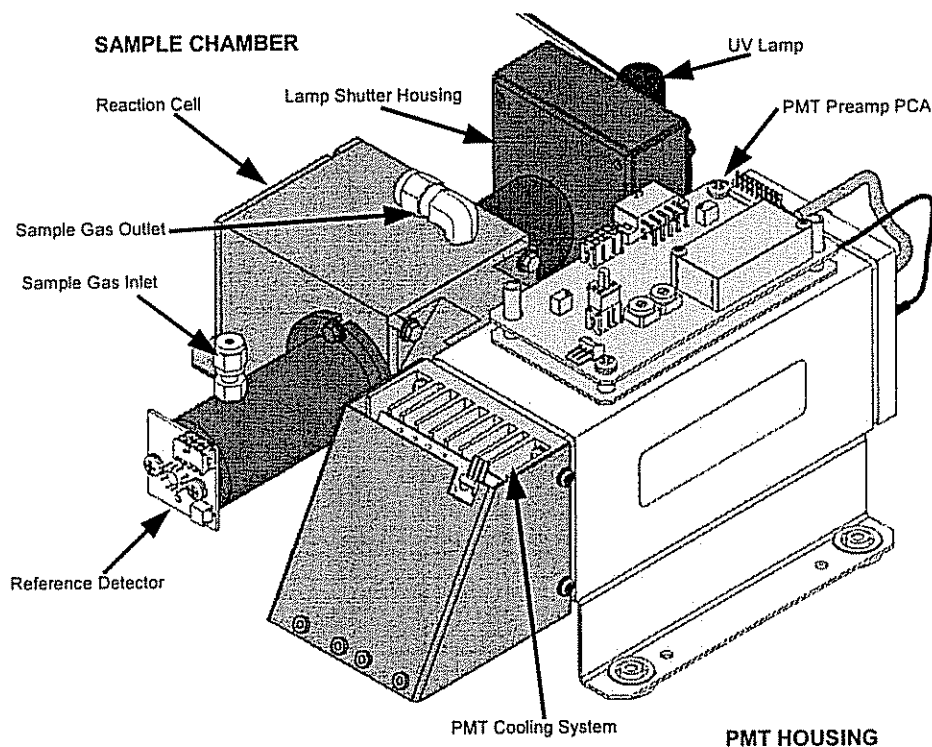

Figure 10-12: 6400E Sensor Module

These components are divided into two significant subassemblies. The sample chamber and the PMT assembly.

- Figure 10-13 shows an exploded view of the sample chamber assembly
- Figure 10-14 shows an exploded view of the PMT Assembly

10.4.2.1. Sample Chamber

The main electronic components of the sample chamber are the reference detector(see Section 10.2.2); the UV Lamp (see Section 10.2.1) and its electronically operated shutter (see Section 10.2.4); and the sample chamber heating circuit,

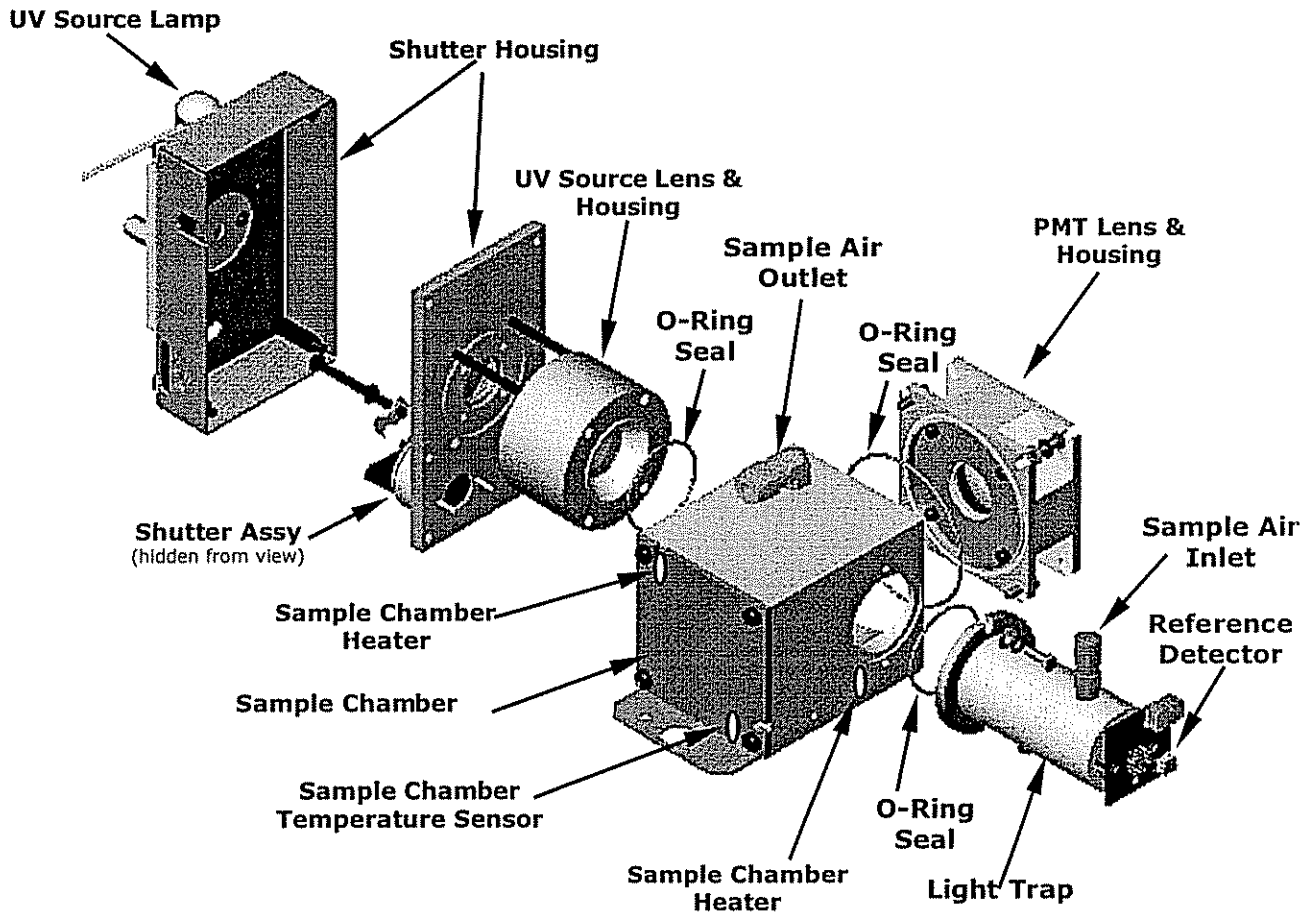

Figure 10-13: 6400E Sample Chamber

10.4.2.2. Sample Chamber Heating Circuit

In order to reduce temperature effects, the sample chamber is maintained at a constant 50°C, just above the high end of the instrument's operation temperature range. Two AC heaters, one embedded into the top of the sample chamber, the other embedded directly below the reference detector's light trap, provide the heat source. These heaters operate off of the instrument's main AC power and are controlled by the CPU through a power relay on the relay board. A thermistor, also embedded in the bottom of the sample chamber, reports the cell's temperature to the CPU through the thermistor interface circuitry of the motherboard.

10.4.3. PHOTO MULTIPLIER TUBE (PMT)

The 6400E uses a photo multiplier tube (PMT) to detect the amount of fluorescence created by the SO_2 and O_3 reaction in the sample chamber.

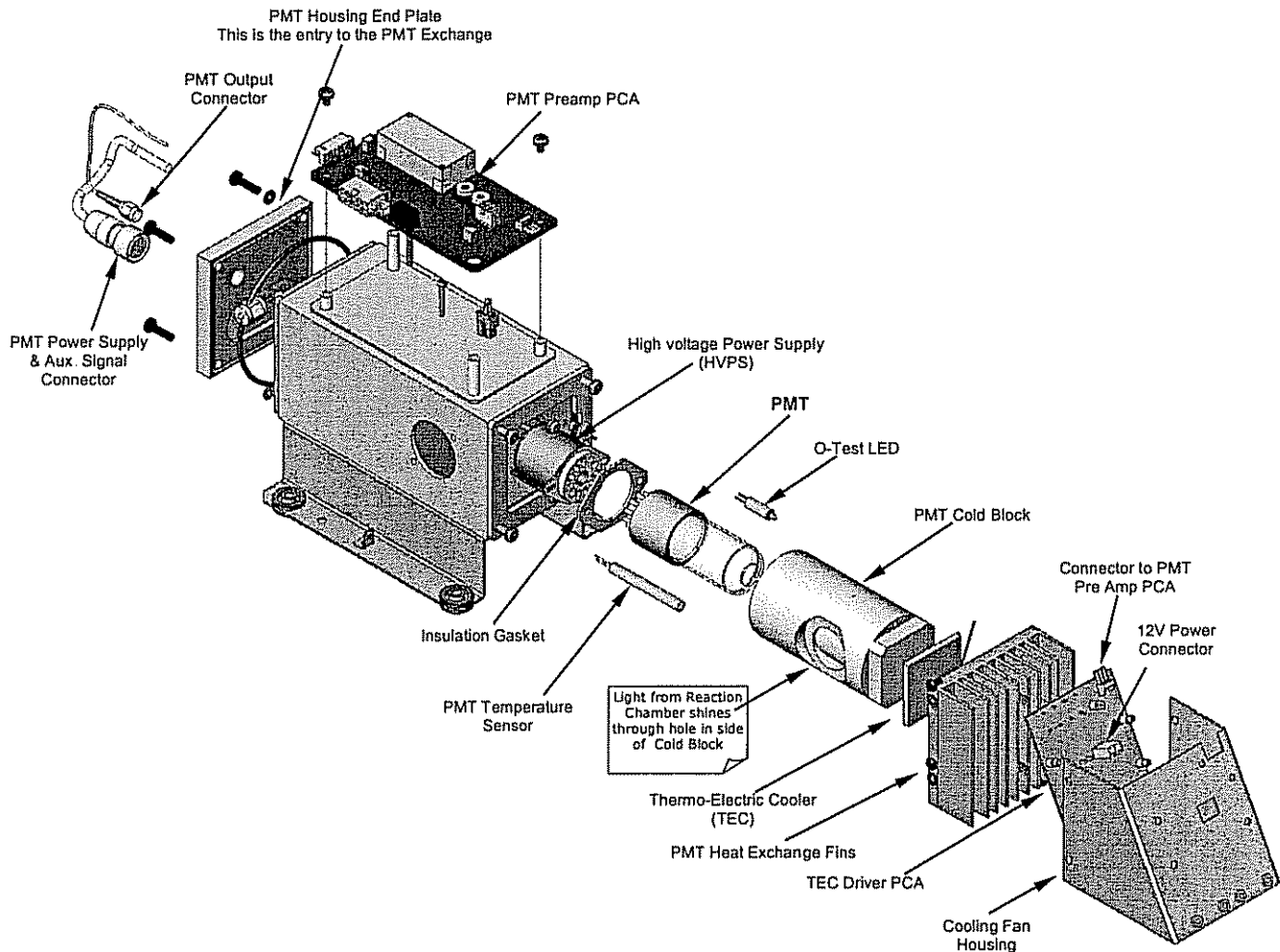

Figure 10-14: PMT Housing Assembly

A typical PMT is a vacuum tube containing a variety of specially designed electrodes. Photons from the reaction are filtered by an optical high-pass filter, enter the PMT and strike a negatively charged photo cathode causing it to emit electrons. A high voltage potential across these focusing electrodes directs the electrons toward an array of high voltage dynodes. The dynodes in this electron multiplier array are designed so that each stage multiplies the number of emitted electrons by emitting multiple, new electrons. The greatly increased number of electrons emitted from one end of electron multiplier are collected by a positively charged anode at the other end, which creates a useable current signal. This current signal is amplified by the preamplifier board and then reported to the motherboard.

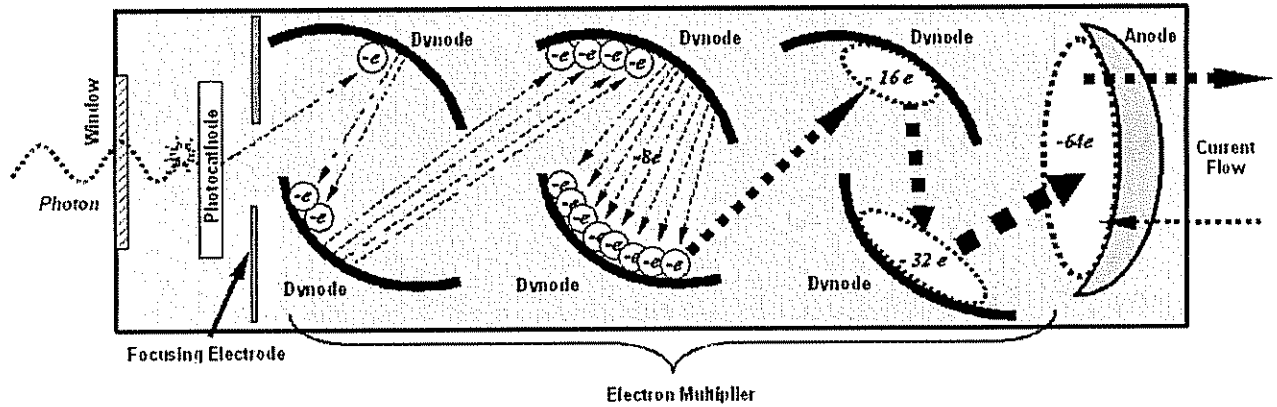

Figure 10-15: Basic PMT Design

A significant performance characteristic of the PMT is the voltage potential across the electron multiplier. The higher the voltage, the greater is the number of electrons emitted from each dynode of the electron multiplier, making the PMT more sensitive and responsive to small variations in light intensity but also more noisy (dark noise). The gain voltage of the PMT used in the 6400E is usually set between 450 V and 800 V. This parameter is viewable through the front panel as test function **HVPS** (see Section 6.2.1). For information on when and how to set this voltage, see Section 11.6.3.8.

The PMT is housed inside the PMT module assembly (see Figure 10-12 & 10-14). This assembly also includes the high voltage power supply required to drive the PMT, an LED used by the instrument's optical test function, a thermistor that measures the temperature of the PMT and various components of the PMT cooling system including the thermo-electric cooler (TEC).

10.4.4. PMT COOLING SYSTEM.

The performance of the analyzer's PMT is significantly affected by temperature. Variations in PMT temperature are directly reflected in the signal output of the PMT. Also the signal to noise ratio of the PMT output is radically influenced by temperature as well. The warmer the PMT is, the noisier its signal becomes until the noise renders the concentration signal useless. To alleviate this problem a special cooling system exists that maintains the PMT temperature at a stable, low level.

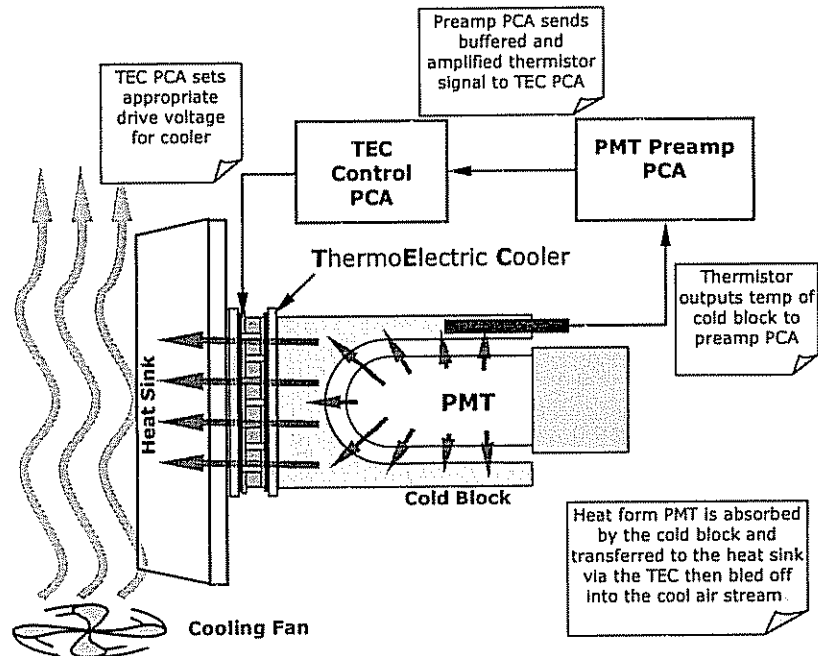

Figure 10-16: PMT Cooling System

10.4.4.1. Thermoelectric Cooler (TEC)

The core of the 6400E PMT cooling system is a solid state heat pump called a thermoelectric cooler (TEC). Thermoelectric coolers transfer heat from one side of a special set of semiconductor junctions to the other when a DC current is applied. The heat is pumped at a rate proportional to the amount of current applied. In the Model 6400E the TEC is physically attached to a cold block that absorbs heat directly from the PMT and a heat sink that is cooled by moving air (see Figure 10-16). A Thermocouple embedded into the cold block generates an analog voltage corresponding to the current temperature of the PMT. The PMT Preamp PCA conditions and amplifies this signal then passes it on to the TEC Control PCA.

10.4.4.2. TEC Control Board

The TEC control printed circuit assembly is located on the sensor housing assembly, under the slanted shroud, next to the cooling fins and directly above the cooling fan. Using the amplified PMT temperature signal from the PMT preamplifier board (see Section 10.4.5), it sets the drive voltage for the thermoelectric cooler. The warmer the PMT gets, the more current is passed through the TEC causing it to pump more heat to the heat sink.

A red LED located on the top edge of this circuit board indicates that the control circuit is receiving power. Four test points are also located at the top of this assembly. For the definitions and acceptable signal levels of these test points see Chapter 11.

10.4.5. PMT PREAMPLIFIER

The PMT preamplifier board amplifies the PMT signal into a useable analog voltage (**PMT**) that can be processed by the motherboard into a digital signal to be used by the CPU to calculate the SO₂ concentration of the gas in the sample chamber.

The output signal of the PMT is controlled by two different adjustments. First, the voltage across the electron multiplier array of the PMT is adjusted with a set of two hexadecimal switches. Adjusting this voltage directly affects the HVPS voltage and, hence, the signal from the PMT. Secondly, the gain of the amplified signal can further be adjusted through a potentiometer. These adjustments should only be performed when encountering problems with the software calibration that cannot be rectified otherwise. See Section 11.6.3.8 for this hardware calibration.

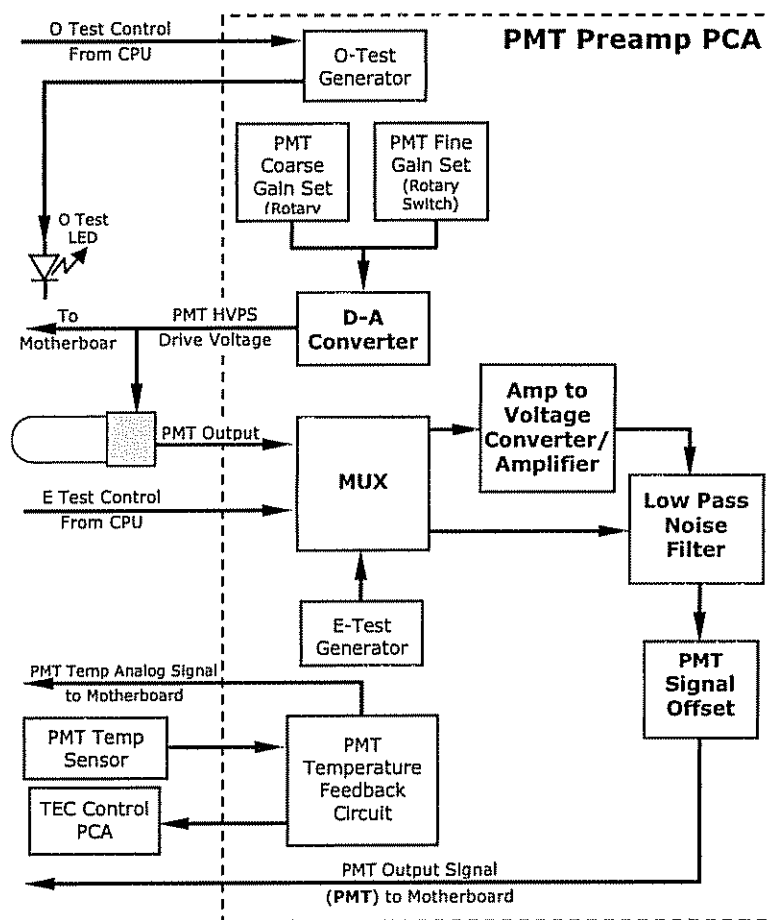

Figure 10-17: PMT Preamp Block Diagram

The PMT temperature control loop maintains the PMT temperature around 7° C and can be viewed as test function **PMT TEMP** on the front panel (see Section 6.2.1).

The electrical test (**ETEST**) circuit generates a constant, electronic signal intended to simulate the output of the PMT (after conversion from current to voltage). By bypassing the detector's actual signal, it is possible to test most of the signal handling and conditioning circuitry on the PMT preamplifier board. See section 6.9.6 for instructions on performing this test.

The optical test (**OTEST**) feature causes an LED inside the PMT cold block to create a light signal that can be measured with the PMT. If zero air is supplied to the analyzer, the entire measurement capability of the sensor module can be tested including the PMT and the current to

voltage conversion circuit on the PMT preamplifier board. See section 6.9.5 for instructions on performing this test.

10.4.6. PNEUMATIC SENSOR BOARD

The flow and pressure sensors of the 6400E are located on a printed circuit assembly just behind the PMT sensor. Refer to Section 11.5.17 on how to test this assembly. The signals of this board are supplied to the motherboard for further signal processing. All sensors are linearized in the firmware and can be span calibrated from the front panel. See section 6.7.5 for instructions on performing this test.

10.4.7. RELAY BOARD

The relay board is the central switching unit of the analyzer. It contains power relays, status LEDs for all heated zones and valves as well as valve drivers, thermocouple amplifiers, power distribution connectors and the two switching power supplies of the analyzer. The relay board communicates with the motherboard over the I²C bus and is the main board for trouble-shooting power problems of any kind.

10.4.7.1. Heater Control

The 6400E uses a variety of heaters for its individual components. All heaters are AC powered and can be configured for 100/120 VAC or 220/230VAC at 50-60 Hz.

The two sample chamber heaters are electronically connected in parallel for analyzers at 100/120 VAC line power and in series for units configured for 220/230 VAC. One configuration plug on the relay board determines the power configuration for the entire analyzer.

On units with IZS options installed, an additional set of AC heaters is attached to the IZS permeation tube. Some special 6400E models may have other, non-standard heating zones installed, such as a dilution manifold.

10.4.7.2. Valve Control

The relay board also hosts two valve driver chips, each of which can drive up four valves. In its basic configuration the Model 6400E requires no special valves to operate. However, on units with either the zero/span valve or the IZS option installed The valves are. Manifold valves may also be present in certain special versions of the analyzer.

10.4.8. STATUS LEDs & WATCH DOG CIRCUITRY

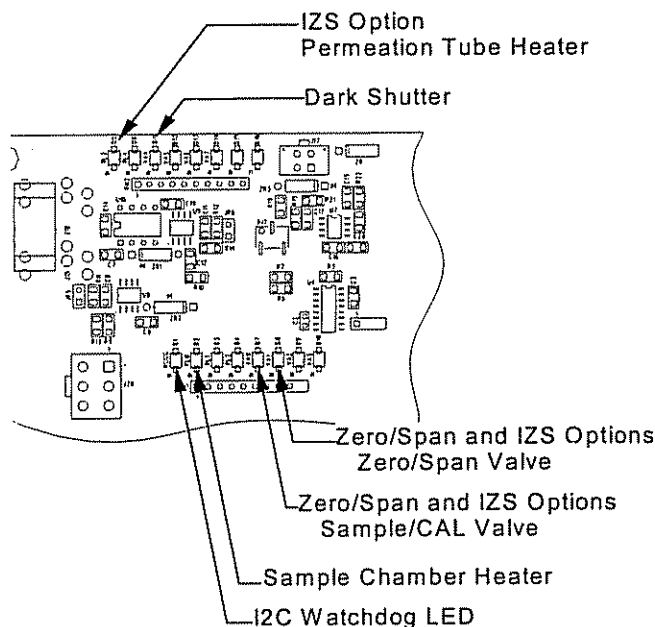

Figure 10-18: Relay Board Status LED Locations

Thirteen LEDs are located on the analyzer's relay board to indicate the status of the analyzer's heating zones and valves as well as a general operating watchdog indicator. Table 10-1 shows the states of these LEDs and their respective functionality.

Table 10-1: Relay Board Status LED's

LED	COLOR	FUNCTION	STATUS WHEN LIT	STATUS WHEN UNLIT
D1	RED	Watchdog circuit	Cycles On/Off every 3 seconds under control of the CPU.	
D2	YELLOW	Sample chamber (RCELL) heater	HEATING	NOT HEATING
D3, D4	YELLOW	Unused	N/A	N/A
D5	YELLOW	IZS heater (option)	HEATING	NOT HEATING
D6	YELLOW	Unused	N/A	N/A
D7	GREEN	Zero / Span Valve	Valve open to Span Gas path	Valve open to Zero Gas (normal state)
D8	GREEN	Sample / Cal Valve	Valve open to calibration gas path	Valve open to sample gas inlet on rear panel (normal state)
D9, D10	GREEN	Unused	N/A	N/A
D11	GREEN	UV Lamp Shutter	Shutter open	Shutter closed
D12-14	GREEN	Unused	N/A	N/A

As a Safety measure, special circuitry on the Relay Board watches the status of LED D1. Should this LED ever stay **ON** or **OFF** for 30 seconds, indicating that the CPU or I²C bus has stopped functioning, the Watchdog Circuit will automatically shut of all valves as well as turn off the UV Source(s) and all heaters. The sample pump will still be running.

10.4.9. MOTHERBOARD

This printed circuit assembly provides a multitude of functions including A/D conversion, digital input/output, PC-104 to I²C translation, temperature sensor signal processing and is a pass through for the RS-232 and RS-485 signals.

10.4.9.1. A to D Conversion

Analog signals, such as the voltages received from the analyzer's various sensors, are converted into digital signals that the CPU can understand and manipulate by the analog to digital converter (A/D). Under the control of the CPU, this functional block selects a particular signal input and then converts the selected voltage into a digital word.

The A/D consists of a voltage-to-frequency (V-F) converter, a programmable logic device (PLD), three multiplexers, several amplifiers and some other associated devices. The V-F converter produces a frequency proportional to its input voltage. The PLD counts the output of the V-F during a specified time period, and sends the result of that count, in the form of a binary number, to the CPU.

The A/D can be configured for several different input modes and ranges but in the is used in unipolar mode with a +5V full scale. The converter includes a 1% over and under-range. This allows signals from -0.05V to +5.05V to be fully converted.

For calibration purposes, two reference voltages are supplied to the A/D converter: Reference ground and +4.096 VDC. During calibration, the device measures these two voltages, outputs their digital equivalent to the CPU. The CPU uses these values to compute the converter's offset and slope and uses these factors for subsequent conversions. See Section 6.9.4.6 for instructions on performing this calibration.

10.4.9.2. Sensor Inputs

The key analog sensor signals are coupled to the A/D through the master multiplexer from two connectors on the motherboard. 100K terminating resistors on each of the inputs prevent cross talk from appearing on the sensor signals.

PMT DETECTOR OUTPUT: This signal, output by the PMT preamp PCA, is used in the computation of the SO₂, SO₂ and SO₂ concentrations displayed at the top right hand corner of the front panel display and output through the instruments analog outputs and **COMM** ports.

PMT HIGH VOLTAGE POWER SUPPLY LEVEL: This input is based on the drive voltage output by the PMT pram board to the PMT's high voltage power supply (HVPS). It is digitized and sent to the CPU where it is used to calculate the voltage setting of the HVPS and stored in the instruments memory as the test function **HVPS**. **HVPS** is viewable as a test function (see Section 6.2.1) through the analyzer's front panel.

PMT TEMPERATURE: This signal is the output of the thermistor attached to the PMT cold block amplified by the PMT temperature feedback circuit on the PMT preamp board. It is digitized and sent to the CPU where it is used to calculate the current temperature of the PMT.

This measurement is stored in the analyzer. Memory as the test function **PMT TEMP** and is viewable as a test function (see Section 6.2.1) through the analyzer's front panel.

SAMPLE GAS PRESSURE SENSOR: This sensor measures the gas pressure at the exit of the sample chamber.

SAMPLE FLOW SENSOR: This sensor measure the flow rate of the sample gas as it exits the sample chamber.

10.4.9.3. Thermistor Interface

This circuit provides excitation, termination and signal selection for several negative-coefficient, thermistor temperature sensors located inside the analyzer. They are:

SAMPLE CHAMBER TEMPERATURE SENSOR: The source of this signal is a thermistor imbedded in the of the sample chamber block. It measures the temperature of the sample gas in the chamber. This data are used by the CPU to control sample chamber the heating circuit and as part of the SO₂, calculations when the instrument's Temperature/Pressure Compensation feature is enabled.

This measurement is stored in the analyzer. Memory as the Test Function **RCEL TEMP** and is viewable as a test function (see Section 6.2.1) through the analyzer's front panel.

IZS OPTION PERMEATION TUBE TEMPERATURE SENSOR: This thermistor, attached to the permeation tube in the IZS option, reports the current temperature of that tube to the CPU as part of control loop that keeps the tube at a constant temperature.

BOX TEMPERATURE SENSOR: A thermistor is attached to the motherboard. It measures the analyzer's inside temperature. This information is stored by the CPU and can be viewed by the user for troubleshooting purposes through the front panel display. This measurement is stored in the analyzer. Memory as the test function **BOX TEMP** and is viewable as a test function (see Section 6.2.1) through the analyzer's front panel.

10.4.10. ANALOG OUTPUTS

The analyzer comes equipped with four Analog Outputs: **A1**, **A2**, **A3** and a fourth that is a spare.

A1 and A2 Outputs: The first two, **A1** and **A2** are normally set up to operate in parallel so that the same data can be sent to two different recording devices. While the names imply that one should be used for sending data to a chart recorder and the other for interfacing with a datalogger, either can be used for both applications.

Both of these channels output a signal that is proportional to the SO₂ concentration of the sample gas. The **A1** and **A2** outputs can be slaved together or set up to operated independently. A variety of scaling factors are available, See Section 6.7 for information on setting the range type and Section 6.9.4 for adjusting the electronic scaling factors of these output channels

Test Output: The third analog output, labeled **A3** is special. It can be set by the user (see Section 6.9.10) to carry the signal level of any one of the parameters accessible through the **TEST** menu of the unit's software.

In its standard configuration, the Analyzer comes with all four of these channels set up to output a DC voltage. However, 4-20mA current loop drivers can be purchased for the first two of these outputs, **A1** and **A2** (see Section 5.2).

Output Loop-back: All three of the functioning analog outputs are connected back to the A/D converter through a Loop-back circuit. This permits the voltage outputs to be calibrated by the CPU without need for any additional tools or fixtures (see Section 6.9.4.2)

10.4.11. EXTERNAL DIGITAL I/O

This External Digital I/O performs two functions.

STATUS OUTPUTS: Logic-Level voltages are output through an optically isolated 8-pin connector located on the rear panel of the analyzer. These outputs convey good/bad and on/off information about certain analyzer conditions. They can be used to interface with certain types of programmable devices (see Section 6.12.1.1).

CONTROL INPUTS: By applying +5VDC power supplied from an external source such as a PLC or Datalogger (see Section 6.12.1.2), Zero and Span calibrations can be initiated by contact closures on the rear panel.

10.4.12. I²C DATA BUS

I²C is a two-wire, clocked, bi-directional, digital serial I/O bus that is used widely in commercial and consumer electronic systems. A transceiver on the Motherboard converts data and control signals from the PC-104 bus to I²C. The data is then fed to the Keyboard/Display Interface (see Section 10.6.1.4) and finally onto the Relay Board.

An I²C data bus is used to communicate data and commands between the CPU, the Keyboard/Display Interface and the various switches and relays on the Relay Board.

10.4.13. POWER UP CIRCUIT

This circuit monitors the +5V power supply during start-up and sets the Analog outputs, External Digital I/O ports, and I²C circuitry to specific values until the CPU boots and the instrument software can establish control.

10.5. POWER SUPPLY/ CIRCUIT BREAKER

The analyzer operates on 100 VAC, 115 VAC or 230 VAC power at either 50Hz or 60Hz. Individual units are set up at the factory to accept any combination of these five attributes. As illustrated in Figure 10-19 below, power enters the analyzer through a standard IEC 320 power receptacle located on the rear panel of the instrument. From there it is routed through the ON/OFF switch located in the lower right corner of the front panel.

AC line power is converted stepped down and converted to DC power by two DC power supplies. One supplies +12 VDC, for various valves and valve options, while a second supply provides +5 VDC and ± 15 VDC for logic and analog circuitry as well as the TEC cooler. All AC and DC Voltages are distributed through the Relay Board.

A 6.75 ampere circuit breaker is built into the ON/OFF switch. In case of a wiring fault or incorrect supply power, the circuit breaker will automatically turn off the analyzer.

CAUTION

Should the power circuit breaker trip correct the condition causing this situation before turning the analyzer back on.

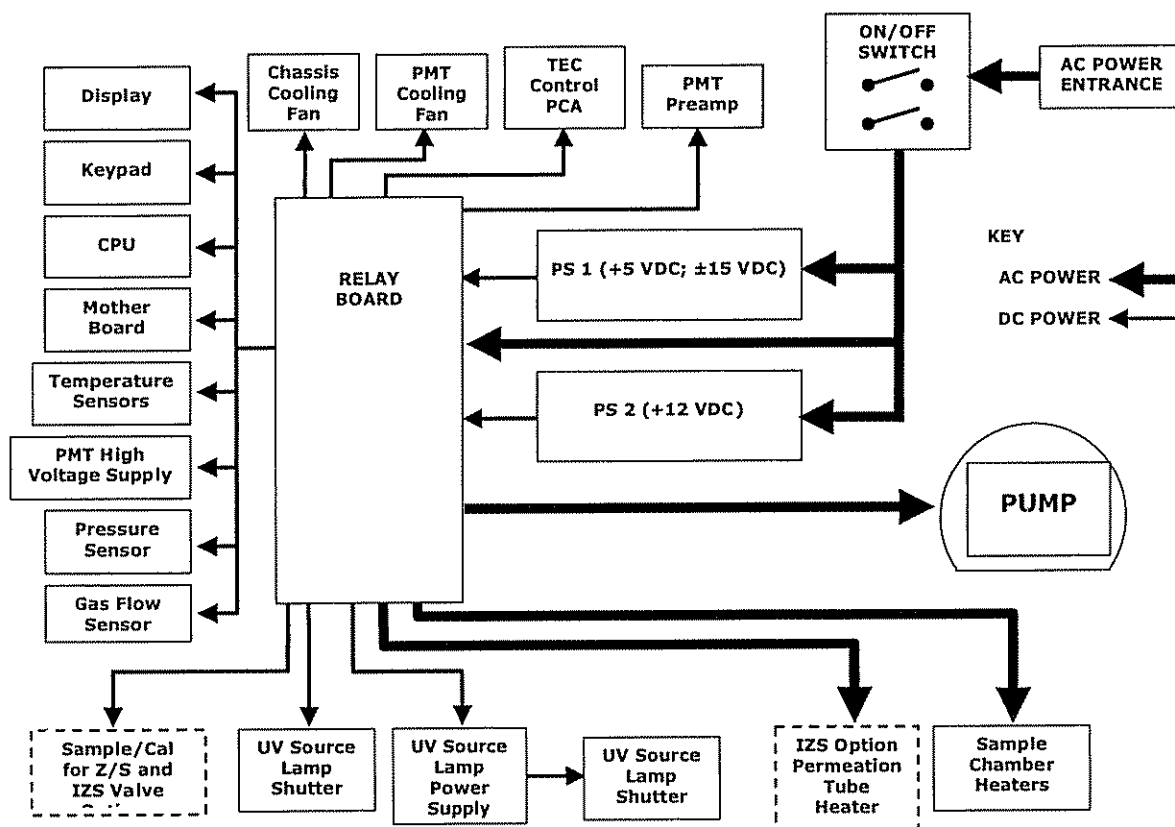

Figure 10-19: Power Distribution Block Diagram

10.6. COMMUNICATIONS INTERFACE

The analyzer has several ways to communicate the outside world, see Figure 10-20. Users can input data and receive information directly through the front panel keypad and display. Direct, two-way communication with the CPU is also available by way of the analyzer's RS232 & RS485 I/O ports (see Section 6.10 and 6.12). Alternatively, an Ethernet communication option can be substituted for one of the COMM ports.

The analyzer can also send status information and data via the eight digital status output lines (see Section 6.12.1.1) and the three analog outputs (see Section 6.7) located on the rear panel as well as receive commands by way of the six digital control inputs also located on the rear panel (see Section 6.12.1.2).

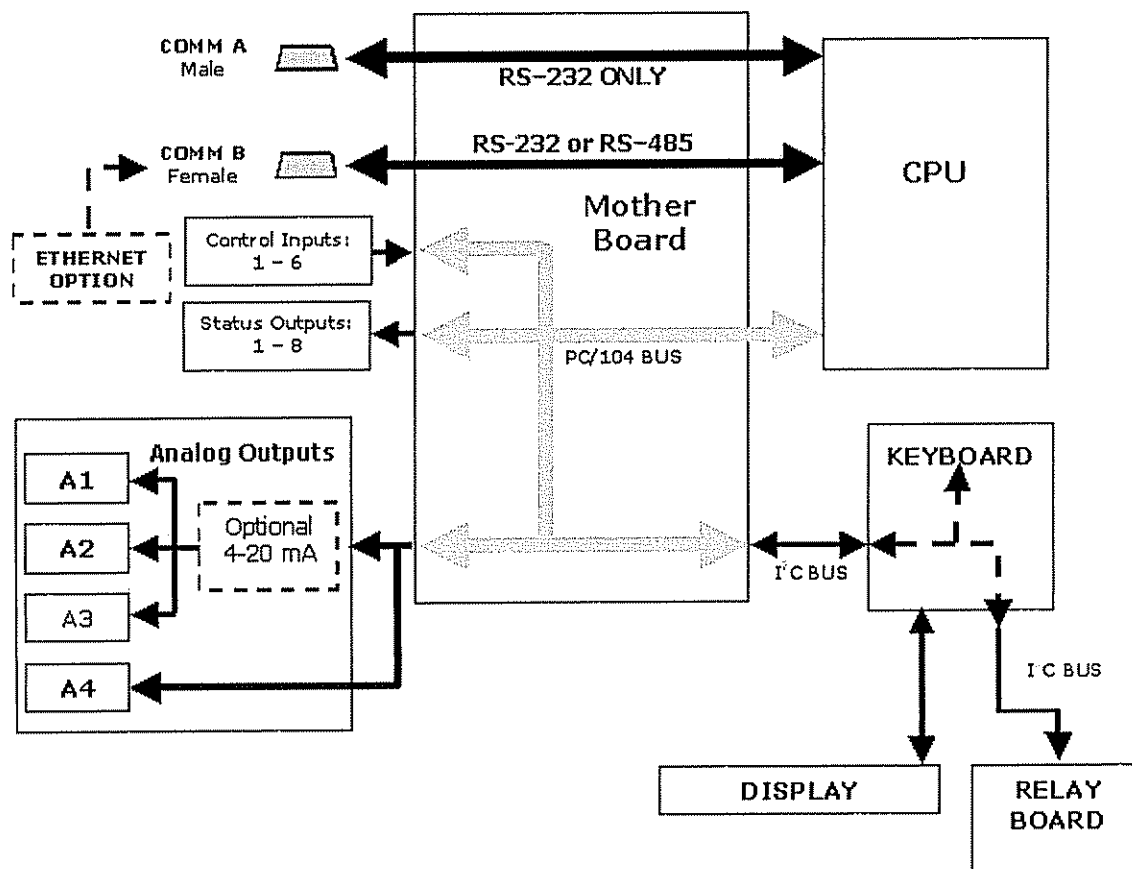

Figure 10-20: Interface Block Diagram

10.6.1. FRONT PANEL INTERFACE

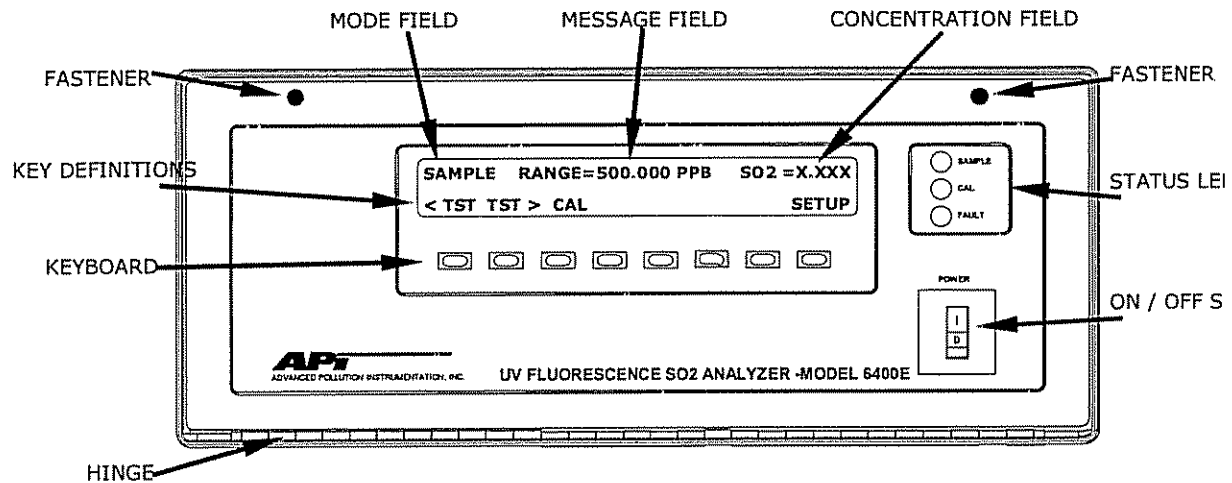

Figure 10-21: 6400E Front Panel Layout

The most commonly used method for communicating with the 6400E UV Fluorescence SO2 Analyzer is via the instrument's front panel which includes a set of three status LEDs, a vacuum fluorescent display and a keyboard with 8 context sensitive keys.

10.6.1.1. Analyzer Status LED's

Three LEDs are used to inform the user of the instruments basic operating status

Table 10-2: Front Panel Status LED's

NAME	COLOR	STATE	DEFINITION
SAMPLE	Green	Off	Unit is not operating in sample mode, iDAS is disabled.
		On	Sample Mode active; Front Panel Display being updated, iDAS data being stored.
		Blinking	Unit is operating in sample mode, front panel display being updated, iDAS hold-off mode is ON, iDAS disabled
CAL	Yellow	Off	Auto Cal disabled
		On	Auto Cal enabled
		Blinking	Unit is in calibration mode
FAULT	Red	Off	SO ₂ warnings exist
		Blinking	Warnings exist

10.6.1.2. Keyboard

A row of eight keys just below the vacuum fluorescent display (see Figure 10-21) is the main method by which the user interacts with the analyzer. As the software is operated, labels appear on the bottom row of the display directly above each active key, defining the function of that key

as it is relevant for the operation being performed. Pressing a key causes the associated instruction to be performed by the analyzer.

Note that the keys do not auto-repeat. In circumstances where the same key must be activated for two consecutive operations, it must be released and re-pressed.

10.6.1.3. Display

The main display of the analyzer is a vacuum florescent display with two lines of 40 text characters each. Information is organized in the following manner (see Figure 10-21):

Mode Field: Displays the name of the analyzer's current operating mode.

Message Field: Displays a variety of informational messages such as warning messages, operation data and response messages during interactive tasks.

Concentration Field: Displays the actual concentration of the sample gas currently being measured by the analyzer

Keypad Definition Field: Displays the definitions for the row of keys just below the display. These definitions dynamic, context sensitive and software driven.

10.6.1.4. Keyboard/Display Interface Electronics

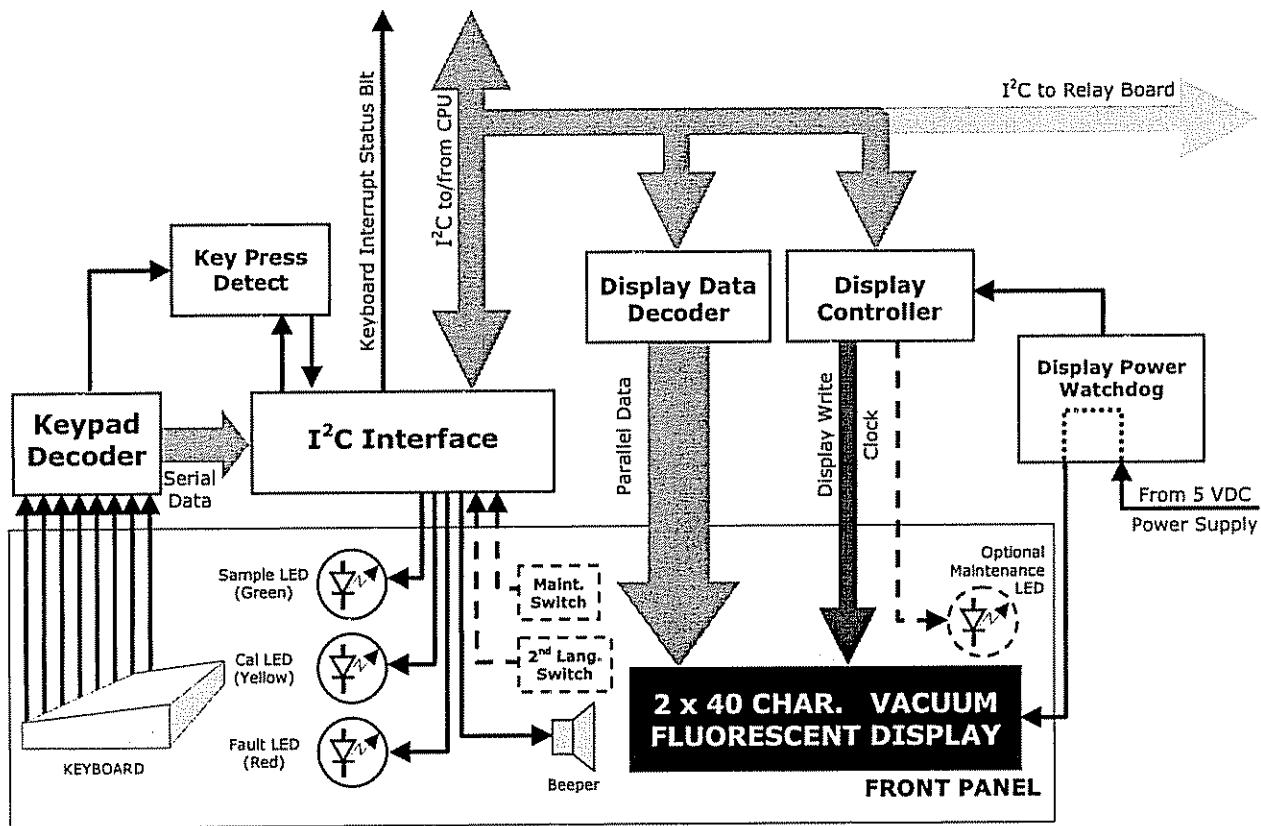

Figure 10-22: Keyboard and Display Interface Block Diagram

The keyboard/display interface electronics of the 6400E Analyzer watches the status of the eight front panel keys, alerts the CPU when keys are depressed, translates data from parallel to serial and back and manages communications between the keyboard, the CPU and the front panel display. Except for the Keyboard interrupt status bit, all communication between the CPU and the keyboard/display is handle by way of the instrument's I²C buss. The CPU controls the clock signal and determines when the various devices on the bus are allowed to talk or required to listen. Data packets are labeled with addresses that identify for which device the information is intended.

Keypad Decoder

Each key on the front panel communicates with a decoder IC via a separate analog line. When a key is depressed the decoder chip notices the change of state of the associated signal; latches and holds the state of all eight lines (in effect creating an 8-bit data word); alerts the key-depress-detect circuit (a flip-flop IC); translates the 8-bit word into serial data and; sends this to the I²C interface chip.

Key-Depress-Detect Circuit

This circuit flips the state of one of the inputs to the I²C interface chip causing it to send an interrupt signal to the CPU

I²C Interface Chip

- This IC performs several functions:
- Using a dedicated digital status bit, it sends an interrupt signal alerting the CPU that new data from the keyboard is ready to send.
- Upon acknowledgement by the CPU that it has received the new keyboard data, the I²C interface chip resets the key-depress-detect flip-flop.
- In response to commands from the CPU, it turns the front panel status LEDs on and off and activates the beeper.
- Informs the CPU when the optional maintenance and second language switches have been opened or closed (see Chapter 5 for information on these options).

Display Data Decoder

This decoder translates the serial data sent by the CPU (in TTY format) into a bitmapped image which is sent over a parallel data bus to the display.

Display Controller

This circuit manages the interactions between the display data decoder and the display itself. It generates a clock pulse that keeps the two devices synchronized. It can also, in response to commands from the CPU turn off and/or reset the display.

Additionally, for analyzers with the optional maintenance switch is installed (See Chapter 5), the display controller turns on an LED located on the back of the keyboard interface PCA whenever the instrument is placed in maintenance mode.

Display Power Watchdog

The Model 6400E's display can begin to show garbled information or lock-up if the DC voltage supplied to it falls too low, even momentarily. To alleviate this, a brown-out watchdog circuit

monitors the level of the power supply and in the event that the voltage level falls below a certain level resets the display by turning it off, then back on.

I²C Link To The Relay PCA

While the CPU's I²C communication with the relay board is also routed through the keyboard/display interface, information passed to and from the relay board via this channel is not recognized by, acted upon or affected by the circuitry of the keyboard/display interface.

10.7. SOFTWARE OPERATION

The 6400E SO₂ analyzer is at its heart a high performance, 386-based microcomputer running MS-DOS. Inside the DOS shell, special software developed by TAI interprets user commands via the various interfaces, performs procedures and tasks, stores data in the CPU's various memory devices and calculates the concentration of the sample gas.

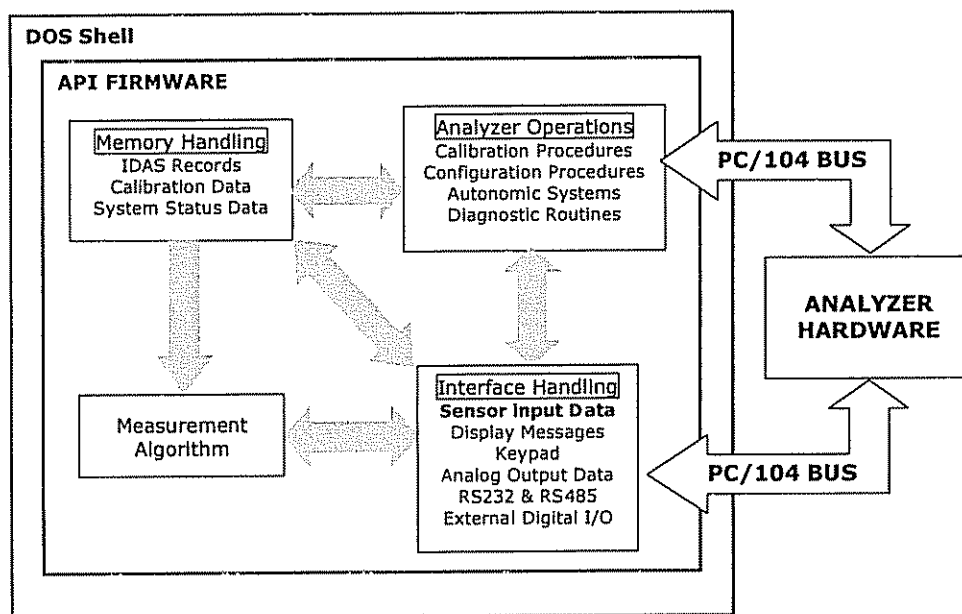

Figure 10-23: Basic Software Operation

10.7.1. ADAPTIVE FILTER

The 6400E SO₂ analyzer software processes sample gas measurement and reference data through a built-in adaptive filter built into the software. Unlike other analyzers that average the sensor output signal over a fixed time period, the 6400E calculates averages over a set number of samples. During operation, the software automatically switches between two filters of different lengths based on the conditions at hand.

During conditions of constant or nearly constant concentration the software computes an average of the last 240 samples. This provides the calculation portion of the software with smooth stable readings. If a rapid change in concentration is detected, the adaptive filter switches modes and only averages the last 48 samples. This allows the analyzer to respond to the rapidly changing concentration more quickly. Once triggered, the short filter remains engaged for a fixed time period to prevent chattering.

Two conditions must be simultaneously met to switch to the short filter. First the instantaneous concentration must exceed the average in the long filter by a fixed amount. Second, the instantaneous concentration must exceed the average in the long filter by a portion, or percentage, of the average in the long filter.

If necessary, these filter lengths of these two modes may be changed to any value between 1 and 1000 samples. Long sample lengths provide better signal to noise rejection, but poor response times. Conversely shorter filter lengths result in poor signal to noise rejection, but quicker response times.

10.7.2. CALIBRATION - SLOPE AND OFFSET

Calibration of the analyzer is performed exclusively in software. During instrument calibration (see Chapters 7 and 8) the user enters expected values for zero and span through the front panel keypad and commands the instrument to make readings of sample gases with know concentrations of SO₂. The readings taken are adjusted, linearized, and compared to the expected values as input. With this information the software computes values for instrument both slope and offset and stores these values in memory for use in calculating the SO₂ concentration of the sample gas.

Instrument slope and offset values recorded during the last calibration can be viewed by pressing the following keystroke sequence

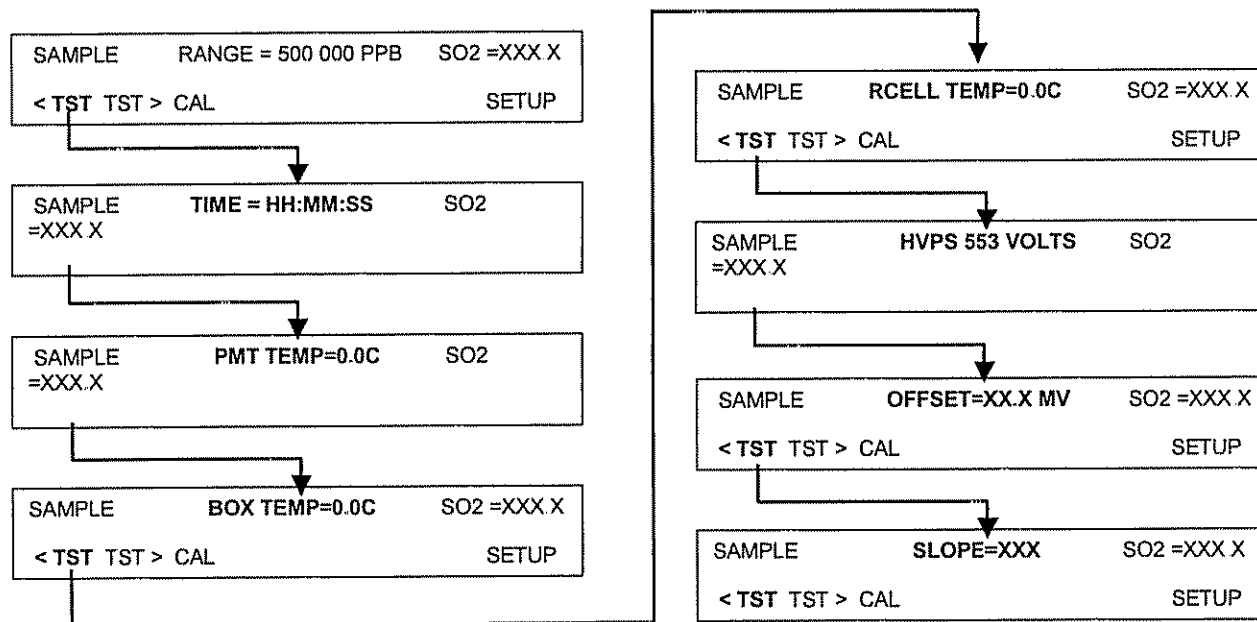

10.7.3. TEMPERATURE AND PRESSURE COMPENSATION (TPC) FEATURE

As explained in the theory of operations (see Chapter 10) changes in temperature can significantly effect the amount of fluoresced UV light generated in the instruments sample chamber. To negate this effect the Model 6400E maintains the sample gas at a stable, raised temperature.

Pressure changes can also have a noticeable, if more subtle, effect on the SO₂ concentration calculation. To account for this, the Model 6400E software includes a feature which allows the instrument to compensation of the SO₂ calculations based on changes in ambient pressure.

When the TPC feature is enabled, the analyzer's SO₂ concentration divided by a factor call PRESSCO which is based on the difference between the ambient pressure of the sample gas normalized to standard atmospheric pressure (Equation 10-5). As ambient pressure increases, the compensated SO₂ concentration is decreased.

$$PRESSCO = \frac{SAMPLE_PRESSURE (" HG - A) \times SAMP_PRESS_SLOPE}{29.92 (" HG - A)}$$

Equation 10-5

SAMPLE-PRESSURE: The ambient pressure of the sample gas as measured by the instrument's sample pressure sensor in "Hg-A.

SAMP_PRESS_SLOPE: Sample pressure slope correction factor. The default setting for Section 6.8 describes the method for enabling/disabling the TPC feature.

10.7.4. INTERNAL DATA ACQUISITION SYSTEM (IDAS)

The iDAS is designed to implement predictive diagnostics that stores trending data for users to anticipate when an instrument will require service. Large amounts of data can be stored in non-volatile memory and retrieved in plain text format for further processing with common data analysis programs. The iDAS has a consistent user interface in all Teledyne Analytical instruments. New data parameters and triggering events can be added to the instrument as needed.

Depending on the sampling frequency and the number of data parameters the iDAS can store several months of data, which are retained even when the instrument is powered off or a new firmware is installed. The iDAS permits users to access the data through the instrument's front panel or the remote interface. The latter can automatically download stored data for further processing. For information on using the iDAS, refer to Sections 6.11.

User Notes:

11. TROUBLESHOOTING & REPAIR

This section contains a variety of methods for identifying and solving performance problems with the analyzer.

	<p style="text-align: center;">Caution</p> <p style="text-align: center;">The operations outlined in this chapter must be performed by qualified maintenance personnel only.</p>
---	--

	<p style="text-align: center;">CAUTION</p> <p>Risk of electrical shock. Some operations need to be carried out with the analyzer open and running. Exercise caution to avoid electrical shocks and electrostatic or mechanical damage to the analyzer. Do not drop tools into the analyzer or leave those after your procedures. Do not shorten or touch electric connections with metallic tools while operating inside the analyzer. Use common sense when operating inside a running analyzer.</p>
---	---

<p style="text-align: center;">NOTE</p>
<p>The front panel of the analyzer is hinged at the bottom and may be opened to gain access to various components mounted on the panel itself or located near the front of the instrument (such as the particulate filter).</p> <p>A locking screw located at the top center of the panel and two fasteners located in the upper right and left corners of the panel lock it shut (see Figure 3-10).</p>

11.1. GENERAL TROUBLESHOOTING

The analyzer has been designed so that problems can be rapidly detected, evaluated and repaired. During operation, the analyzer continuously performs diagnostic tests and provides the ability to evaluate its key operating parameters without disturbing monitoring operations.

A systematic approach to troubleshooting will generally consist of the following five steps:

- Note any warning messages and take corrective action as necessary.
- Examine the values of all TEST functions and compare them to factory values. Note any major deviations from the factory values and take corrective action.
- Use the internal electronic status LED's to determine whether the electronic communication channels are operating properly. Verify that the DC power supplies are operating properly by checking the voltage test points on the relay board. Note that the analyzer's DC power wiring is color-coded and these colors match the color of the corresponding test points on the relay board.
- Suspect a leak first! Customer service data indicate that half of all problems are eventually traced to leaks in the pneumatic system of the analyzer, the source of zero air or span

gases or the sample gas delivery system. Check for gas flow problems such as clogged or blocked internal/external gas lines, damaged seals, punctured gas lines, a damaged pump diaphragm, etc.

- Follow the procedures defined in Section 11.5 for confirming that the analyzer's basic components are working (power supplies, CPU, relay board, keyboard, PMT cooler, etc.). See Figure 3-9 for general layout of components and sub-assemblies in the analyzer. See the wiring interconnect drawing and interconnect list, see Appendix D.

11.1.1. WARNING MESSAGES

The most common and/or serious instrument failures will result in a warning message displayed on the front panel. Table A-2 in Appendix A-3 contains a list of warning messages, along with their meaning and recommended corrective action.

It should be noted that if more than two or three warning messages occur at the same time, it is often an indication that some fundamental analyzer sub-system (power supply, relay board, motherboard) has failed rather than an indication of the specific failures referenced by the warnings. In this case, a combined-error analysis needs to be performed.

The analyzer will alert the user that a warning is active by displaying the keypad labels **MSG** and **CLR** on the front panel and a text message in the top center line of the display as shown in this example:



The analyzer will also issue a message to the serial port and cause the red FAULT LED on the front panel to blink.

To view or clear a warning message press:

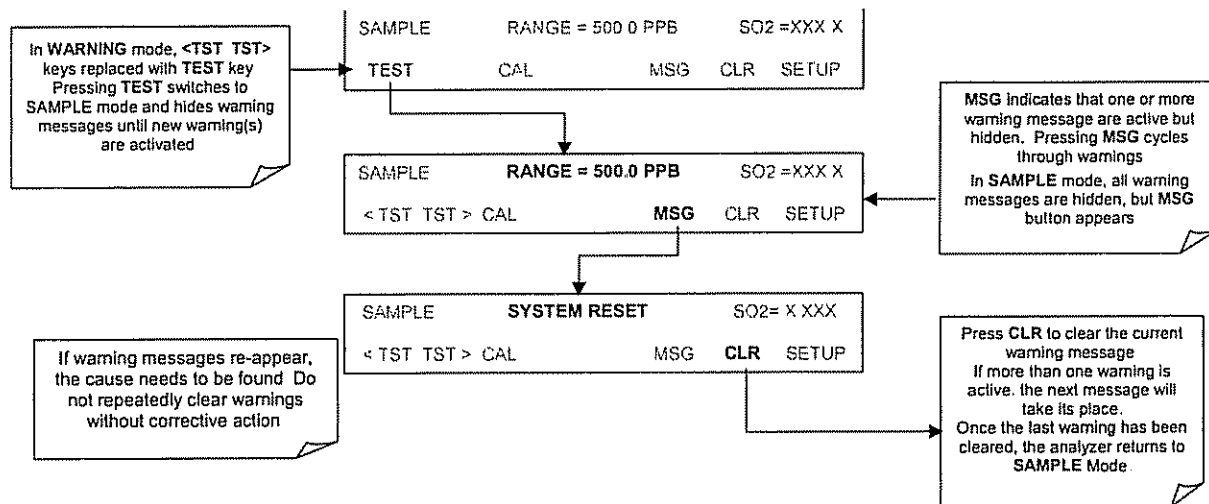

Figure 11-1: Viewing and Clearing warning messages

Table 11-1: Warning Messages - Indicated Failures

WARNING MESSAGE	FAULT CONDITION	POSSIBLE CAUSES
ANALOG CAL WARNING	The instruments A/D circuitry or one of its analog outputs is not calibrated	A parameter for one of the analog outputs, even one not currently being used, has been changed and the analog output calibration routine was not re-run A/D circuitry failure on motherboard Other motherboard electronic failure
BOX TEMP WARNING	Box Temp is < 5 °C or > 48 °C.	NOTE: Box temperature typically runs ~7°C warmer than ambient temperature. Poor/blocked ventilation to the analyzer. Stopped exhaust-fan Ambient temperature outside of specified range
CANNOT DYN SPAN	Dynamic Span operation failed	Measured concentration value is too high or low. Concentration slope value to high or too low
CANNOT DYN ZERO	Dynamic Zero operation failed	Measured concentration value is too high. Concentration offset value to high.
CONFIG INITIALIZED	Configuration and Calibration data reset to original Factory state.	Failed disk on chip User erased data
DARK CAL WARNING	The Dark Cal signal is higher than 200 mV.	Light leak in reaction cell Shutter solenoid is not functioning Failed relay board I ² C bus failure Loose connector/wiring PMT preamp board bad or out of cal
DATA INITIALIZED	Data Storage in IDAS was erased	Failed disk on chip User cleared data
FRONT PANEL WARN	The CPU is unable to Communicate with the Front Panel Display /Keyboard	Warning only appears on serial I/O com port(s) Front panel display will be frozen, blank or will not respond. Failed keyboard I ² C buss failure Loose connector/wiring
HVPS WARNING	High voltage power supply output is <400 V or >900 V	High voltage power supply is bad High voltage power supply is out of cal A/D converter circuitry is bad
IZS TEMP WARNING	On units with IZS options installed: The permeation tube temperature is Sample chamber temperature is < 45°C or > 55°C	Bad IZS heater Bad IZS temperature sensor Bad relay controlling the IZS heater Entire relay board is malfunctioning I ² C buss malfunction Failure of thermistor interface circuitry on motherboard
PMT DET WARNING	PMT detector output is > 4995 mV	Failed PMT Malfunctioning PMR preamp board A/D converter circuitry failure
PMT TEMP WARNING	PMT temperature is < 2°C or > 12°C	Bad PMT thermo-electric cooler Failed PMT TEC driver circuit Bad PMT preamp board Failed PMT temperature sensor Loose wiring between PMT temperature sensor and PMT Preamp board Malfunction of analog sensor input circuitry on motherboard
RCELL TEMP WARNING	Sample chamber temperature is < 45°C or > 55°C	Bad reaction cell heater Bad reaction cell temperature sensor Bad relay controlling the reaction cell heater Entire relay board is malfunctioning I ² C buss malfunction
REAR BOARD NOT DET	Mother Board not detected on power up.	Warning only appears on serial i/o com port(s) Front panel display will be frozen, blank or will not respond. Massive failure of mother board.

Table 11-1: Warning Messages - Indicated Failures (cont.)

WARNING MESSAGE	FAULT CONDITION	POSSIBLE CAUSES
SAMPLE FLOW WARN	Sample flow rate is < 500 cc/min or > 1000 cc/min.	Failed sample pump Blocked sample inlet/gas line Dirty particulate filter Leak downstream of critical flow orifice Failed flow sensor/circuitry
SAMPLE PRES WARN	Sample Pressure is <10 in-Hg or > 35 in-Hg ¹	If sample pressure is < 10 in-hg: <ul style="list-style-type: none"> o Blocked particulate filter o Blocked sample inlet/gas line o Failed pressure sensor/circuitry If sample pressure is > 35 in-hg: <ul style="list-style-type: none"> o Blocked vent line on pressurized sample/zero/span gas supply o Bad pressure sensor/circuitry
SYSTEM RESET	The computer has rebooted.	This message occurs at power on. If it is confirmed that power has not been interrupted: Failed +5 VDC power, Fatal error caused software to restart Loose connector/wiring
UV LAMP WARNING	The UV lamp intensity is < 600mV or > 4995 mV	UV lamp is bad Reference detector is bad or out of adjustment. Mother board analog sensor input circuitry has failed. Fogged or damaged lenses/filters in UV light path A/D converter circuitry failure Light leak in reaction cell Shutter solenoid stuck closed
¹ Normally 29.92 in-Hg at sea level decreasing at 1 in-Hg per 1000 ft of altitude (with no flow – pump disconnected).		

11.1.2. FAULT DIAGNOSIS WITH TEST FUNCTIONS

Besides being useful as predictive diagnostic tools, the TEST functions, viewable from the front panel, can be used to isolate and identify many operational problems when combined with a thorough understanding of the analyzer's theory of operation (see Chapter 10). We recommend use of the APICOM remote control program to download, graph and archive TEST data for analysis, and long-term monitoring of diagnostic data.

The acceptable ranges for these test functions are listed in Table A-3 in Appendix A-3. The actual values for these test functions on checkout at the factory were also listed in the *Final Test and Validation Data Sheet*, which was shipped with the instrument. Values outside the acceptable ranges indicate a failure of one or more of the analyzer's subsystems. Functions with values that are within the acceptable range but have significantly changed from the measurements recorded on the factory data sheet may also indicate a failure or a maintenance item. A problem report worksheet has been provided in Appendix C to assist in recording the value of these test functions. Table 11-2 contains some of the more common causes for these values to be out of range.

Table 11-2: Test Functions - Possible Causes for Out-Of-Range Values

TEST FUNCTION	NOMINAL VALUE(S)	POSSIBLE CAUSE(S)
STABIL	≤1 ppb with zero air	Faults that cause high stability values are: pneumatic leak; low or very unstable UV lamp output; light leak; faulty HVPS; defective preamp board; aging detectors; PMT recently exposed to room light; dirty/contaminated reaction cell.
SAMPLE FL	650 cm ³ /min ± 10%	Faults are caused due to: clogged critical flow orifice ;pneumatic leak; faulty flow sensor; sample line flow restriction.
PMT	-20 TO 150 mV with zero air	High or noisy readings could be due to: calibration error; pneumatic leak; excessive background light; aging UV filter; low UV lamp output; PMT recently exposed to room light; light leak in reaction cell; reaction cell contaminated HVPS problem. <i>It takes 24-48 hours for the PMT exposed to ambient light levels to adapt to dim light.</i>
NORM PMT		Noisy Norm PMT value (assuming unchanging SO ₂ concentration of sample gas): Calibration error; HVPS problem; PMT problem.
UV LAMP SIGNAL	3500 mV ± 200mV	This is the instantaneous reading of the UV lamp intensity. Low UV lamp intensity could be due to: aging UV lamp; UV lamp position out of alignment; faulty lamp transformer; aging or faulty UV detector; UV detector needs adjusting; dirty optical components. Intensity lower than 600 mV will cause UV LAMP WARNING . Most likely cause is a UV lamp in need of replacement.
LAMP RATIO	30 TO 120%	The current output of the UV reference detector divided by the reading stored in the CPU's memory from the last time a UV Lamp calibration was performed. Out of range lamp ratio could be due to: malfunctioning UV lamp; UV lamp position out of alignment; faulty lamp transformer; aging or faulty UV detector; dirty optical components; pin holes or scratches in the UV optical filters; light leaks.
STR LGT	40-100 ppb	High stray light could be caused by: aging UV filter; contaminated reaction cell; light leak; pneumatic leak.
DRK PMT	-50 - +200 mV	High dark PMT reading could be due to: light leak; shutter not closing completely; high pmt temperature; high electronic offset.
DRK LMP	-50 - +200 mV	High dark UV detector could be caused by: light leak; shutter not closing completely; high electronic offset.
HVPS	≈ 400 V to 900 V	Incorrect HVPS reading could be caused by; HVPS broken; preamp board circuit problems.
RCELL TEMP	50°C ± 1°C	Incorrect temperature reading could be caused by: malfunctioning heater; relay board communication (I ² C bus); relay burnt out
BOX TEMP	ambient + ~ 5°C	Incorrect temperature reading could be caused by: Environment out of temperature operating range; broken thermistor; runaway heater
PMT TEMP	7°C ± 2°C constant	Incorrect temperature reading could be caused by: TEC cooling circuit broken; High chassis temperature; 12V power supply
IZS TEMP (OPTION)	50°C ± 1°C	Malfunctioning heater; relay board communication (I ² C bus); relay burnt out
PRESS	ambient ± 2 IN-HG-A	Incorrect sample gas pressure could be due to: pneumatic leak; malfunctioning valve; malfunctioning pump; clogged flow orifices; sample inlet overpressure; faulty pressure sensor
SLOPE	1.0 ± 0.3	Slope out of range could be due to: poor calibration quality ; span gas concentration incorrect; leaks; UV Lamp output decay.
OFFSET	< 250 mV	High offset could be due to: incorrect span gas concentration/contaminated zero air/leak; low-level calibration off; light leak; aging UV filter; contaminated reaction cell; pneumatic leak.
TIME OF DAY	Current time	Incorrect Time could be caused by: Internal clock drifting; move across time zones; daylight savings time?

11.1.3. USING THE DIAGNOSTIC SIGNAL I/O FUNCTIONS

The signal I/O parameters found under the diagnostics (DIAG) menu combined with a thorough understanding of the instrument's theory of operation (see Chapter 10) are useful for troubleshooting in three ways:

- The technician can view the raw, unprocessed signal level of the analyzer's critical inputs and outputs.
- All of the components and functions that are normally under instrument control can be manually changed.
- Analog and digital output signals can be manually controlled.

This allows to systematically observe the effect of these functions on the operation of the analyzer. Figure 11-2 shows an example of how to use the signal I/O menu to view the raw voltage of an input signal or to control the state of an output voltage or control signal. The specific parameter will vary depending on the situation. Please note that the analyzer will freeze it's concentration output while in the diagnostic signal I/O menu. This is because manually changing I/O outputs can invalidate the instrument reading.

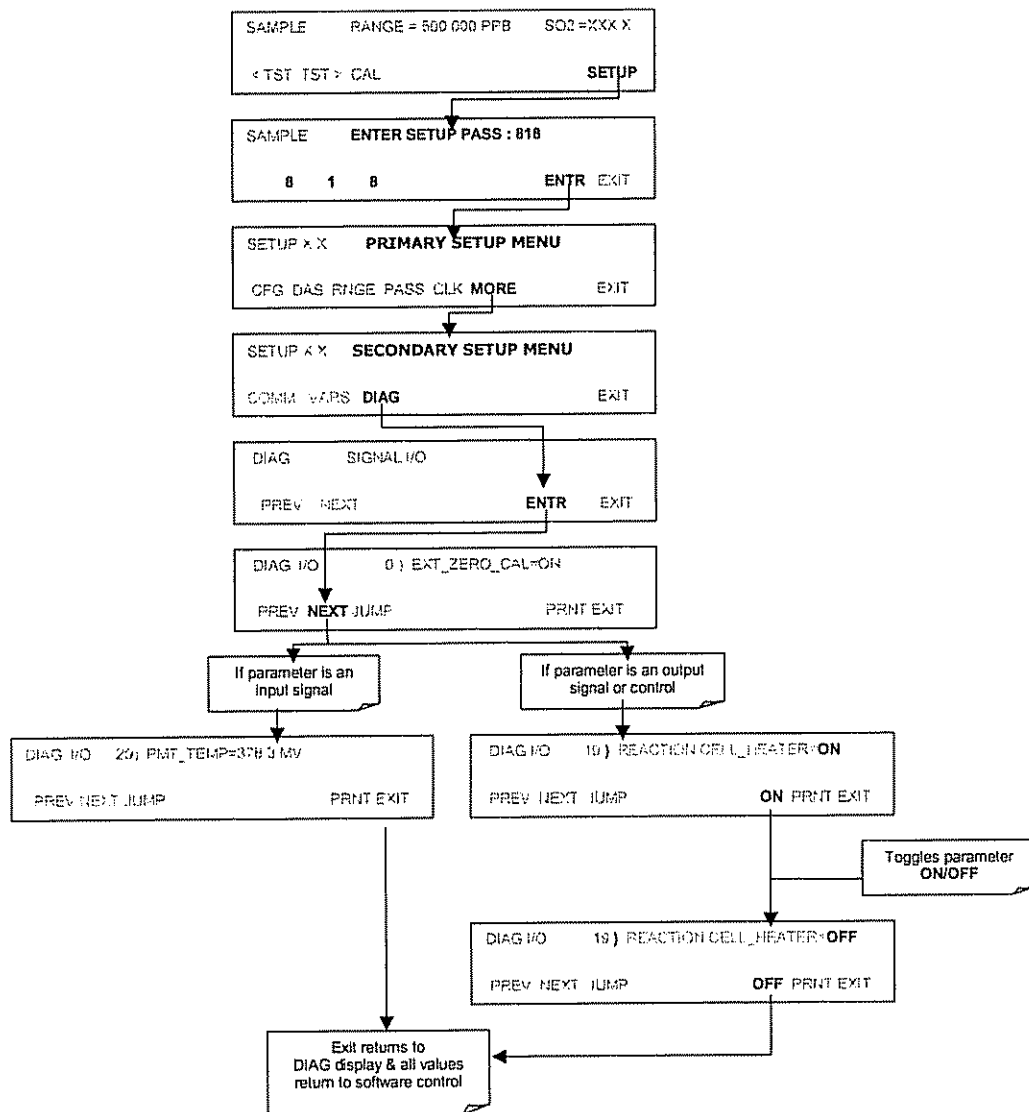

Figure 11-2: Example of Signal I/O Function

11.1.4. STATUS LEDS

Several color-coded, light-emitting diodes (LEDs) are located inside the instrument to determine if the analyzer's CPU, I²C communications bus and relay board are functioning properly.

11.1.4.1. Motherboard Status Indicator (Watchdog)

DS5, a red LED on the upper portion of the motherboard, just to the right of the CPU board, flashes when the CPU is running the main program. After power-up, DS5 should flash on and off about once per second. If characters are written to the front panel display but DS5 does not flash then the program files have become corrupted. Contact Teledyne Instruments customers service department.

If, 30 - 60 seconds after a restart, DS5 is not flashing and no characters have been written to the front panel display, the firmware may be corrupted or the CPU may be defective. If DS5 is permanently off or permanently on, the CPU board is likely locked up and the analyzer should not respond (either with locked-up or dark front panel).

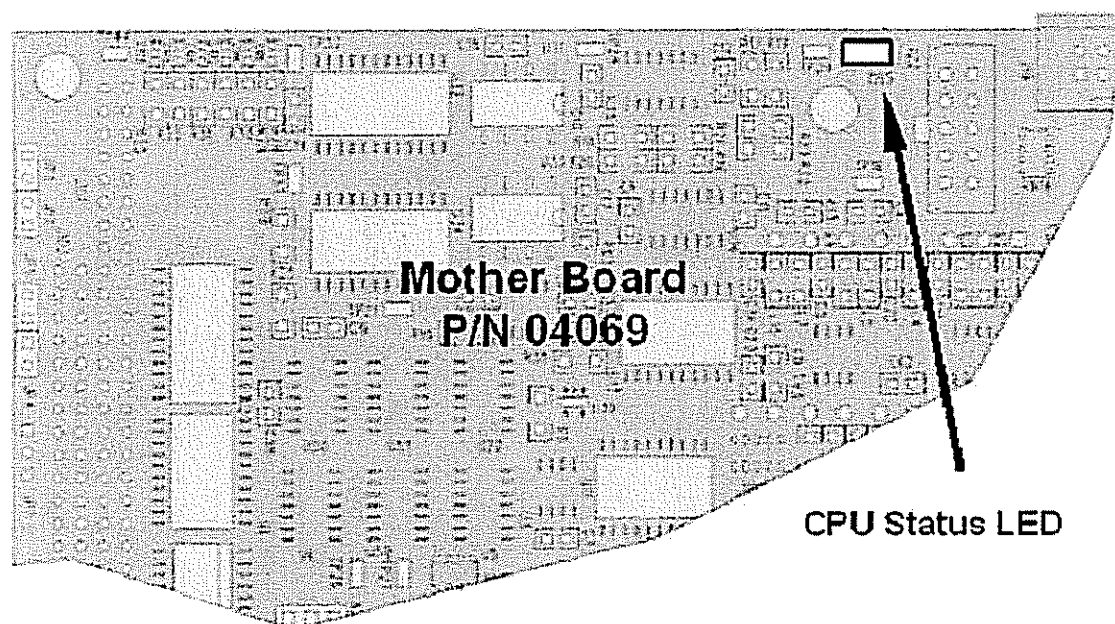

Figure 11-3: CPU Status Indicator

11.1.4.2. CPU Status Indicator

The CPU board has two red LEDs. LED1 is the upper-most LED and is a +5V power indicator, so it should always be on. However, both CPU LEDs only indicate if the CPU is powered up properly and generally working. The lower LED will sometimes be stable, and sometimes will blink. It can continue to blink even if the CPU or firmware are locked up, and is not an effective indicator for debugging system problems.

11.1.4.3. Relay Board Status LEDs

The most important status LED on the relay board is the red I¹C Bus watch-dog LED, labeled **D1** (or W/D), which indicates the health of the I¹C communications bus. This LED is located in the upper left-hand corner of the relay board when looking at the electronic components. If D1 is blinking, then the other LED's can be used in conjunction with the **DIAG** menu I/O functions to test hardware functionality by switching devices on and off and watching the corresponding LED go on or off. The LED only indicates that the logic signal for an output has been activated. If the output driver (i.e. the relay or valve driver IC) is defective, then the LED will light up, but the attached peripheral device will not turn on.

Table 11-3: Relay Board Status LEDs

LED	COLOR	FUNCTION	FAULT STATUS	INDICATED FAILURE(S)
D1	red	Watchdog Circuit; I ¹ C bus operation.	Continuously ON or OFF	Failed or halted CPU; faulty motherboard, keyboard, relay board; wiring between motherboard, keyboard or relay board; +5 V power supply.
D2	yellow	Relay 0 - sample chamber heater	Continuously ON or OFF	Heater broken, thermistor broken
D3	yellow	SPARE	N/A	N/A
D4	yellow	SPARE	N/A	N/A
D5	yellow	Relay 3 - IZS heater	Continuously ON or OFF	Heater broken, thermistor broken
D6	yellow	Spare	N/A	N/A
D7 ¹	green	Zero/span valve status	Continuously ON or OFF	Valve broken or stuck, valve driver chip broken
D8 ¹	green	Sample/cal valve status	Continuously ON or OFF	Valve broken or stuck, valve driver chip broken
D9	green	SPARE	N/A	N/A
D10	green	SPARE	N/A	N/A
D11	green	UV Lamp Shutter	Continuously ON or OFF	Shutter jammed or stuck; faulty relay board; problem with wiring between relay board & shutter.
D12	green	SPARE	N/A	N/A
D13	green	SPARE	N/A	N/A
D14	green	SPARE	N/A	N/A
D15	green	SPARE	N/A	N/A
D16	Green	SPARE	N/A	N/A

¹ Only active for instruments with Z/S valve or IZS options installed

11.2. GAS FLOW PROBLEMS

The standard 6400E has one main flow path. With the IZS option installed, there is a second flow path through the IZS oven that runs whenever the IZS is on standby to purge SO₂ from the oven chamber. The IZS flow is not measured and is not available from the front panel. The full flow diagrams of the standard configuration (see Figure 3-5) and with options installed (see Figure 5-2 and 5-3) help in trouble-shooting flow problems. In general, flow problems can be divided into three categories:

- Flow is too high
- Flow is greater than zero, but is too low, and/or unstable
- Flow is zero (no flow)

When troubleshooting flow problems, it is essential to confirm the actual flow rate without relying on the analyzer's flow display. The use of an independent, external flow meter to perform a flow check as described in Section 11.5.2 is essential.

11.2.1. ZERO OR LOW SAMPLE FLOW

If the pump is operating but the unit reports a **XXXX** gas flow, do the following three steps:

- Check for actual sample flow
- Check pressures
- Carry out a leak check

To check the actual sample flow, disconnect the sample tube from the sample inlet on the rear panel of the instrument. Make sure that the unit is in basic SAMPLE mode. Place a finger over the inlet and see if it gets sucked in by the vacuum or, more properly, use a flow meter to measure the actual flow. If there is proper flow of around 650 cm³/min, contact customer service. If there is no flow or low flow, continue with the next step.

Check that the sample pressure is at or around 28 (or about 1 in-Hg-A below ambient atmospheric pressure).

11.2.2. HIGH FLOW

Flows that are significantly higher than the allowed operating range (typically ± 10 -11% of the nominal flow) should not occur in the 6400E unless a pressurized sample, zero or span gas is supplied to the inlet ports. Be sure to vent excess pressure and flow just before the analyzer inlet ports.

When supplying sample, zero or span gas at ambient pressure, a high flow would indicate that one or more of the critical flow orifices are physically broken (very unlikely case), allowing more than nominal flow, or were replaced with an orifice of wrong specifications. If the flows are more than 15% higher than normal, we recommend that the technician find and correct the cause of the flow problem,

11.3. CALIBRATION PROBLEMS

11.3.1. NEGATIVE CONCENTRATIONS

Negative concentration values can be caused for several things:

- A slight, negative signal is normal when the analyzer is operating under zero gas and the signal is drifting around the zero calibration point. This is caused by the analyzer's zero noise and may cause reported concentrations to be negative for a few seconds at a time down to -5 ppb, but should alternate with similarly high, positive values.
- Mis-calibration is the most likely explanation for negative concentration values. If the zero air contained some SO₂ gas (contaminated zero air or a worn-out zero air scrubber) and the analyzer was calibrated to that concentration as "zero", the analyzer may report negative values when measuring air that contains little or no SO₂. The same problem occurs, if the analyzer was zero-calibrated using ambient air or span gas.
- If the response offset test function for SO₂ (**OFFSET**) are greater than 150 mV, a failed PMT or high voltage supply, or sample chamber contamination, could be the cause.

11.3.2. NO RESPONSE

If the instrument shows no response (display value is near zero) even though sample gas is supplied properly and the instrument seems to perform correctly,

- Confirm response by supplying SO₂ span gas of about 80% of the range value to the analyzer.
- Check the sample flow rate for proper value.
- Check for disconnected cables to the sensor module.
- Carry out an electrical test with the **ELECTRICAL TEST** procedure in the diagnostics menu, see Section 6.9.6. If this test produces a concentration reading, the analyzer's electronic signal path is working.
- Carry out an optical test using the **OPTIC TEST** procedure in the diagnostics menu, see Section 6.9.5. If this test results in a concentration signal, then the PMT sensor and the electronic signal path are operating properly. If the 6400E passes both ETEST and OTEST, the instrument is capable of detecting light and processing the signal to produce a reading. Therefore, the problem must be in the pneumatics, optics or the UV lamp/lamp driver.

11.3.3. UNSTABLE ZERO AND SPAN

Leaks in the 6400E or in the external gas supply and vacuum systems are the most common source of unstable and non-repeatable concentration readings.

- Check for leaks in the pneumatic systems as described in Section 11.5.1. Consider pneumatic components in the gas delivery system outside the 6400E such as a change in zero air source (ambient air leaking into zero air line or a worn-out zero air scrubber) or a change in the span gas concentration due to zero air or ambient air leaking into the span gas line.
- Once the instrument passes a leak check, do a flow check (see Section 11.5.2) to make sure that the instrument is supplied with adequate sample gas.
- Confirm the UV lamp, sample pressure and sample temperature readings are correct and steady.
- Verify that the sample filter element is clean and does not need to be replaced.

11.3.4. INABILITY TO SPAN - NO SPAN KEY

In general, the 6400E will not display certain keyboard choices whenever the actual value of a parameter is outside of the expected range for that parameter. If the calibration menu does not show a SPAN key when carrying out a span calibration, the actual concentration must be outside of the range of the expected span gas concentration, which can have several reasons.

- Verify that the expected concentration is set properly to the actual span gas concentration in the **CONC** sub-menu.
- Confirm that the SO₂ span gas source is accurate.
- If you are using bottle calibration gas and have recently changed bottles, bottle to bottle variation may be the cause.
- Check for leaks in the pneumatic systems as described in Section 11.5.1. Leaks can dilute the span gas and, hence, the concentration that the analyzer measures may fall short of the expected concentration defined in the **CONC** sub-menu.
- If the physical, low-level calibration has drifted (changed PMT response) or was accidentally altered by the user, a low-level calibration may be necessary to get the analyzer back into its proper range of expected values. One possible indicator of this scenario is a slope or offset value that is outside of its allowed range (0.7-1.3 for slope, -20 to 150 for offsets). See Section 11.6.3.8 on how to carry out a low-level hardware calibration.

11.3.5. INABILITY TO ZERO - NO ZERO KEY

In general, the 6400E will not display certain keyboard choices whenever the actual value of a parameter is outside of the expected range for that parameter. If the calibration menu does not show a ZERO key when carrying out a zero calibration, the actual gas concentration must be significantly different from the actual zero point (as per last calibration), which can have several reasons.

- Confirm that there is a good source of zero air. If the IZS option is installed, compare the zero reading from the IZS zero air source to an external zero air source using SO₂-free air. Check any zero air scrubber for performance. It may need to be replaced (see Section 9.3.3).

- Check to make sure that there is no ambient air leaking into the zero air line. Check for leaks in the pneumatic systems as described in Section 11.5.1.

11.3.6. NON-LINEAR RESPONSE

The 6400E was factory calibrated and should be linear to within 1% of full scale. Common causes for non-linearity are

- Leaks in the pneumatic system. Leaks can add a constant of ambient air, zero air or span gas to the current sample gas stream, which may be changing in concentrations as the linearity test is performed. Check for leaks as described in Section 11.5.
- The calibration device is in error. Check flow rates and concentrations, particularly when using low concentrations. If a mass flow calibrator is used and the flow is less than 10% of the full scale flow on either flow controller, you may need to purchase lower concentration standards.
- The standard gases may be mislabeled as to type or concentration. Labeled concentrations may be outside the certified tolerance.
- The sample delivery system may be contaminated. Check for dirt in the sample lines or sample chamber.
- Calibration gas source may be contaminated.
- Dilution air contains sample or span gas.
- Sample inlet may be contaminated with SO₂ exhaust from this or other analyzers. Verify proper venting of the analyzer's exhaust.
- Span gas overflow is not properly vented and creates a back-pressure on the sample inlet port. Also, if the span gas is not vented at all and does not supply enough sample gas, the analyzer may be evacuating the sample line. Make sure to create and properly vent excess span gas.
- If the instrument is equipped with an internal IZS valve option and the SO₂ span value is continuously trending downward, the IZS permeation tube may require replacement

11.3.7. DISCREPANCY BETWEEN ANALOG OUTPUT AND DISPLAY

If the concentration reported through the analog outputs does not agree with the value reported on the front panel, you may need to re-calibrate the analog outputs. This becomes more likely when using a low concentration or low analog output range. Analog outputs running at 0.1 V full scale should always be calibrated manually. See Section 6.9.4.3. for a detailed description of this procedure.

11.4. OTHER PERFORMANCE PROBLEMS

Dynamic problems (i.e. problems which only manifest themselves when the analyzer is monitoring sample gas) can be the most difficult and time consuming to isolate and resolve. The following section provides an itemized list of the most common dynamic problems with recommended troubleshooting checks and corrective actions.

11.4.1. EXCESSIVE NOISE

Excessive noise levels under normal operation usually indicate leaks in the sample supply or the analyzer itself. Make sure that the sample or span gas supply is leak-free and carry out a detailed leak check as described earlier in this chapter.

Another possibility of excessive signal noise may be the preamplifier board, the high voltage power supply and/or the PMT detector itself. Contact the factory on trouble-shooting these components.

11.4.2. SLOW RESPONSE

If the analyzer starts responding too slowly to any changes in sample, zero or span gas, check for the following:

- Dirty or plugged sample filter or sample lines.
- Sample inlet line is too long.
- Dirty or plugged critical flow orifices. Check flows, pressures and, if necessary, change orifices (see Section 9.3.6.).
- Wrong materials in contact with sample - use Teflon materials only.
- Sample vent line is located too far from the instrument sample inlet and causes long mixing and purge times. Locate sample inlet (overflow) vent as close as possible to the analyzer's sample inlet port.
- Dirty sample chamber.
- Insufficient time allowed for purging of lines upstream of the analyzer.
- Insufficient time allowed for SO₂ calibration gas source to become stable.

11.4.3. THE ANALYZER DOESN'T APPEAR ON THE LAN OR INTERNET

Most problems related to internet communications via the Ethernet card option will be due to problems external to the analyzer (e.g. bad network wiring or connections, failed routers, malfunctioning servers, etc.) However there are several symptoms that indicate the problem may be with the Ethernet card itself.

- If none of the Ethernet's cards four status LED's (located on the analyzer's rear panel) is lit, it is possible that the card is not receiving power or is suffering from a massive failure.
- Under the **Setup – CFG** menu (see Section 6.5) the firmware revision of the iChip processor on the Ethernet card should be listed. It will appear something like:

```
SAMPLE      iChip Rev. IL702P16 1.3
NEXT  PREV                                EXIT
```

- If "?????" appears as the revision number, something is preventing the iChip from being initialized.
- On initial start up after iChip driver is enabled the analyzer's COMM port driver tests the iChip to determine the baud rate at which it is set to function. This test occurs when the instrument is approximately 75% through its boot-up procedure and takes about 90 seconds to complete.

This test should only occur on the initial start up of the analyzer after the Ethernet card is installed and activated (usually at the factory). A 90 second pause at this point in its boot process every time it is turned on could indicate that a problem exists with the iChip itself, the Ethernet card or the analyzer's Disk-on-Chip memory that is preventing it from holding the proper baud rate setting for the **COM2** port in memory.

11.5. SUBSYSTEM CHECKOUT

The preceding sections of this manual discussed a variety of methods for identifying possible sources of failures or performance problems within the analyzer. In most cases this included a list of possible causes and, in some cases, quick solutions or at least a pointer to the appropriate sections describing them. This section describes how to determine if a certain component or subsystem is actually the cause of the problem being investigated.

11.5.1. DETAILED PRESSURE LEAK CHECK

Obtain a leak checker similar to TAI part number 01960, which contains a small pump, shut-off valve, and pressure gauge to create both over-pressure and vacuum. Alternatively, a tank of pressurized gas, with the two stage regulator adjusted to ≤ 15 psi, a shutoff valve and pressure gauge may be used.

CAUTION

Once tube fittings have been wetted with soap solution under a pressurized system, do not apply or re-apply vacuum as this will cause soap solution to be sucked into the instrument, contaminating inside surfaces.

Do not exceed 15 psi when pressurizing the system.

1. Turn OFF power to the instrument and remove the instrument cover.
2. Install a leak checker or a tank of gas (compressed, oil-free air or nitrogen) as described above on the sample inlet at the rear panel.
3. Pressurize the instrument with the leak checker or tank gas, allowing enough time to fully pressurize the instrument through the critical flow orifice.
 - Check each tube connection (fittings, hose clamps) with soap bubble solution, looking for fine bubbles.
 - Once the fittings have been wetted with soap solution, do not re-apply vacuum as it will draw soap solution into the instrument and contaminate it.
 - Do not exceed 15 psi pressure.
4. If the instrument has the zero and span valve option, the normally closed ports on each valve should also be separately checked. Connect the leak checker to the normally closed ports and check with soap bubble solution.
5. If the analyzer is equipped with an IZS Option Connect the leak checker to the Dry Air inlet and check with soap bubble solution.
6. Once the leak has been located and repaired, the leak-down rate of the indicated pressure should be less than 1 in-Hg-A (0.4 psi) in 5 minutes after the pressure is turned off.
7. Clean soap solution from all surfaces, re-connect the sample and exhaust lines and replace the instrument cover. Restart the analyzer.

11.5.2. PERFORMING A SAMPLE FLOW CHECK

CAUTION

Use a separate, calibrated flow meter capable of measuring flows between 0 and 1000 cm³/min to measure the gas flow rate through the analyzer. Do not use the built in flow measurement viewable from the front panel of the instrument.

Sample flow checks are useful for monitoring the actual flow of the instrument, to monitor drift of the internal flow measurement. A decreasing, actual sample flow may point to slowly clogging pneumatic paths, most likely critical flow orifices or sintered filters. To perform a sample flow check:

1. Disconnect the sample inlet tubing from the rear panel SAMPLE port shown in Figure 3-1.
2. Attach the outlet port of a flow meter to the sample inlet port on the rear panel. Ensure that the inlet to the flow meter is at atmospheric pressure.
3. The sample flow measured with the external flow meter should be 650 cm³/min \pm 10%.
4. Low flows indicate blockage somewhere in the pneumatic pathway. See troubleshooting chapter 11. for more information on how to fix this.

11.5.3. HYDROCARBON SCRUBBER (*Kicker*)

There are two possible types of problems that can occur with the scrubber: pneumatic leaks and contamination that ruins the inner tube's ability to absorb hydrocarbons.

11.5.3.1. Checking the Scrubber for Leaks

Leaks in the outer tubing of the scrubber can be found using the procedure described in section 11.5.1. Use the following method to determine if a leak exists in the inner tubing of the scrubber.

- This procedure requires a pressurized source of air (chemical composition is unimportant) capable of supplying up to 15 psia an a leak checking fixture such as the one illustrated in Figure 11-4.

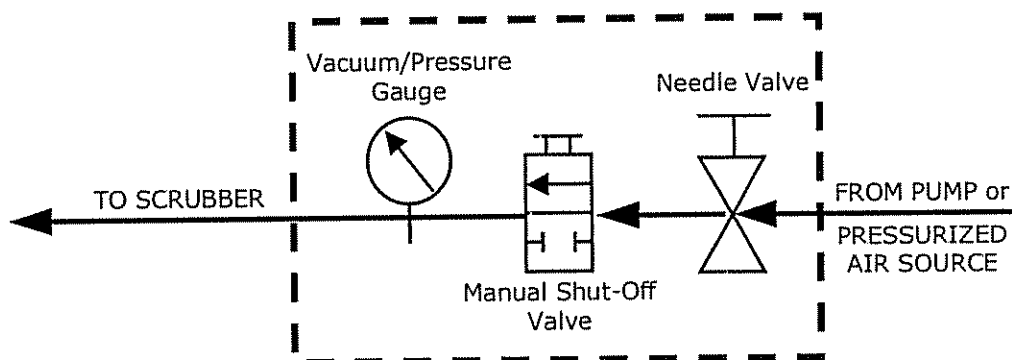

Figure 11-4: Simple Leak Check Fixture

1. Turn off the analyzer
2. Disconnect the pneumatic tubing attached to both ends of the scrubbers inner tubing.
 - One end is connected to the sample particulate filter assembly and the other end is connected to the reaction cell assembly.
 - Both ends are made of the 1/8" black Teflon tubing.
3. Cap one end of the hydrocarbon scrubber.
4. Attach the pressurized air source to the other end of the scrubber inner tubing with the leak check fixture in line.

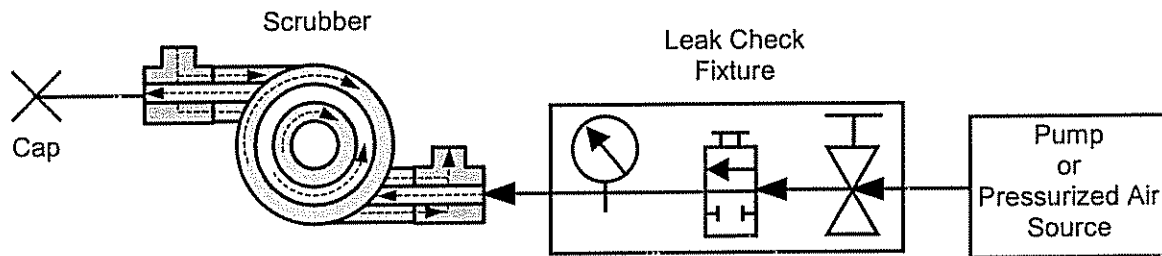

Figure 11-5: Hydrocarbon Scrubber Leach check Set Up

5. Use the needle valve to adjust the air input until the gauge reads 15 psia.

NOTE:

**Do not exceed a pressure of more than 15psia.
Do not pull the vacuum through the scrubber.**

6. Close the shut-off valve.
7. Wait 5 minutes.
 - If the gauge pressure drops is >1 psi within 5 minutes, then the hydrocarbon scrubber has an internal leak and must be replaced.
 - Contact Teledyne Instruments Customer Service.

11.5.3.2. Checking the Scrubber’s Efficiency

CAUTION:



This procedure requires the use of mothballs. Mothball often contain naphthalene and/or paradichlorobenzene. Both of these Avoid prolonged breathing of vapors. Make sure the work area is well ventilated.

Use gloves when handling mothballs.

Store mothballs in an airtight container preferably in a separate room from the analyzer.

To check the ability of the scrubber to efficiently remove hydrocarbons from the sample air:

1. Disconnect the sample gas supply line from the sample inlet at the back of the analyzer.
2. With the instrument operating, watch the SO₂ concentration reading on the analyzer's front panel display. Wait until the reading stabilizes (probably somewhere near 0 ppb).
3. Place a mothball near the sample inlet.
4. Watch the SO₂ concentration reading for 30-40 seconds.
 - If the scrubber is working properly the reading should remain stable.
 - If the reading rises significantly (more than 2-3 ppb) the hydrocarbon scrubber must be replaced.
 - Contact Teledyne Instruments Customer Service.

11.5.4. AC POWER CONFIGURATION

The 6400E digital electronic systems will operate with any of the specified power regimes. As long as the instrument is connected to 100-120 VAC or 220-240 VAC at either 50 or 60 Hz it will turn on and after about 30 seconds show a front panel display. Internally, the status LEDs located on the Motherboard and CPU should turn on as soon as the power is supplied.

On the other hand, the analyzer's various non-digital components, such as the pump, the UV lamp and the AC powered heaters, require that the relay board be properly configured for the type of power being supplied to the instrument.

	<p style="text-align: center;">CAUTION:</p> <p>Plugging the analyzer into a power supply that is too high a voltage or frequency can damage the UV lamp, the pump and the AC!</p> <p>Plugging the analyzer into a power supply that is too low a voltage or frequency will cause these components to not operate properly.</p>
---	---

If an incorrect power configuration is suspected, check the serial number label located on the instrument's rear panel (see figure 3-1) to make sure that the instrument was configured for the same voltage and frequency being supplied.

If the information included on the label matches the line voltage, but you still suspect an AC power configuration problem, check the power configuration jumpers located on the relay board (see figure 11-6).

- If the Jumper block is WHITE the instrument is configured for 115 VAC at 60 Hz.
- If the Jumper block is BLUE the instrument is configured for 220, 240 VAC at 50 Hz.

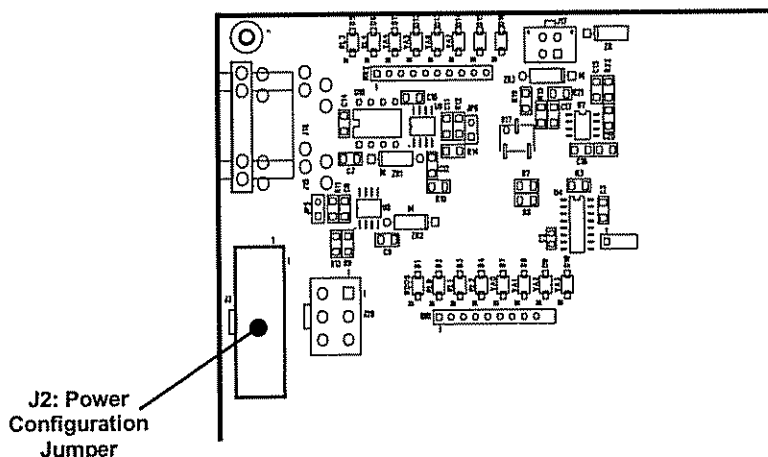

Figure 11-6: Location of Relay Board Power Configuration Jumper

11.5.5. DC POWER SUPPLY

If you have determined that the analyzer’s AC main power is working, but the unit is still not operating properly, there may be a problem with one of the instrument’s switching power supplies, which convert AC power to 5 and ±15 V (PS1) as well as +12 V DC power (PS2). The supplies can either have DC output at all or a noisy output (fluctuating).

To assist tracing DC Power Supply problems, the wiring used to connect the various printed circuit assemblies and DC powered components and the associated test points on the relay board follow a standard color-coding scheme as defined in Table 11-4.

Table 11-4: DC Power Test Point and Wiring Color Code

NAME	TEST POINT#	COLOR	DEFINITION
DGND	1	Black	Digital ground
+5V	2	Red	
AGND	3	Green	Analog ground
+15V	4	Blue	
-15V	5	Yellow	
+12V	6	Purple	
+12R	7	Orange	12 V return (ground) line

A voltmeter should be used to verify that the DC voltages are correct as listed in Table 11-5. An oscilloscope, in AC mode and with band limiting turned on, can be used to evaluate if the supplies are excessively noisy (> 100 mV peak-to-peak).

Table 11-5: DC Power Supply Acceptable Levels

POWER SUPPLY	VOLTAGE	CHECK RELAY BOARD TEST POINTS				MIN V	MAX V
		FROM TEST POINT		TO TEST POINT			
		NAME	#	NAME	#		

PS1	+5	DGND	1	+5	2	+4.80	+5.25
PS1	+15	AGND	3	+15	4	+13.5	+16.0
PS1	-15	AGND	3	-15V	5	-14.0	-16.0
PS1	AGND	AGND	3	DGND	1	-0.05	+0.05
PS1	Chassis	DGND	1	Chassis	N/A	-0.05	+0.05
PS2	+12	+12V Ret	6	+12V	7	+11.8	+12.5
PS2	DGND	+12V Ret	6	DGND	1	-0.05	+0.05

11.5.6. I¹C BUS

Operation of the I¹C bus can be verified by observing the behavior of the LED labeled **D1** on the relay board in conjunction with the performance of the front panel display. Assuming that the DC power supplies are operating properly and the wiring from the motherboard to the keyboard as well as from the keyboard to the relay board is intact, the I¹C bus is operating properly if:

- D1 on the relay board is flashing or
- D1 is not flashing but pressing a key on the front panel results in a change to the display.

If the display is locked up or if the analyzer is not booting up at all, the I¹C bus may be the cause. Contact customer service if you suspect a problem with the I¹C bus.

11.5.7. KEYBOARD / DISPLAY INTERFACE

The front panel keyboard, the display and the keyboard/display circuit board can be verified by observing the operation of the display when power is applied to the instrument and when a key is pressed on the front panel. Assuming that there are no wiring problems and that the DC power supplies are operating properly:

- The vacuum fluorescent display is working properly if, on power-up, a "-" character is visible on the upper left hand corner of the display.
- If the analyzer starts operation with a normal display but pressing a key on the front panel does not change the display, then there are three possible problems:
 - One or more of the keys is bad
 - The interrupt signal between the keyboard circuit and the motherboard is broken due to a cabling problem or
 - The keyboard circuit is bad.

You can verify this failure by logging on to the instrument using APICOM or a terminal program. If the analyzer responds to remote commands and the display changes accordingly, the display wiring or the I¹C bus may be faulty.

11.5.8. RELAY BOARD

The relay board circuit can most easily be checked by observing the condition of its status LEDs as described in Section 11.1.4, and the associated output when toggled on and off through the **SIGNAL I/O** function in the **DIAG** menu, see Section 6.9.2.

- If the front panel display responds to key presses and D1 on the relay board is not flashing, then either the I¹C connection between the motherboard and the relay board is bad, or the relay board itself is bad.
- If D1 on the relay board is flashing, but toggling an output in the **Signal I/O** function menu does not toggle the output's status LED, then there is a circuit problem, or possibly a blown driver chip, on the relay board.
- If D1 on the Relay board is flashing and the status indicator for the output in question (heater, valve, etc.) toggles properly using the **Signal I/O** function, but the output device does not turn on/off, then the associated device (valve or heater) or its control device (valve driver, heater relay) is malfunctioning.

Several of the control devices are in sockets and can easily be replaced. The table below lists the control device associated with a particular function:

Table 11-6: Relay Board Control Devices

FUNCTION	CONTROL DEVICE	SOCKETED
Valve0 – Valve3	U5	Yes
Valve4 – Valve7	U6	Yes
All heaters	K1-K5	Yes

11.5.9. MOTHERBOARD

11.5.9.1. A/D functions

A basic check of the analog to digital (A/D) converter operation on the motherboard is to use the **Signal I/O** function under the **DIAG** menu. Check the following two A/D reference voltages and input signals that can be easily measured with a voltmeter. Using the **Signal I/O** function (see Section 6.9.2 and Appendix D), view the value of **REF_4096_MV** and **REF_GND**.

- The nominal value for **REF_4096_MV** is 4096 mV \pm 10 mV.
- The nominal value for **REF_GND** is 0 mV \pm 3 mV, respectively, of their nominal values (4096 and 0) and are
- If these signals are stable to within \pm 0.5 mV, the basic A/D converter is functioning properly.
- If these values fluctuate largely or are off by more than specified above, one or more of the analog circuits may be overloaded or the motherboard may be faulty.
- Choose one parameter in the Signal I/O function such as **SAMPLE_PRESSURE** (see previous section on how to measure it). Compare its actual voltage with the voltage

displayed through the **SIGNAL I/O** function. If the wiring is intact but there is a difference of more than ± 10 mV between the measured and displayed voltage, the motherboard may be faulty.

11.5.9.2. Analog Output Voltages

To verify that the analog outputs are working properly, connect a voltmeter to the output in question and perform an analog output step test as described in Section 6.9.3.

For each of the steps, taking into account any offset that may have been programmed into the channel (see Section 6.9.4.4), the output should be within 1% of the nominal value listed in the Table 11-7 except for the 0% step, which should be within 2-3 mV. If one or more of the steps is outside of this range, a failure of one or both D/A converters and their associated circuitry on the motherboard is likely.

Table 11-7: Analog Output Test Function - Nominal Values

STEP	%	FULL SCALE OUTPUT VOLTAGE			
		100MV	1V	5V	10V
		NOMINAL OUTPUT VOLTAGE			
1	0	0 mV	0	0	0
2	20	20 mV	0.2	1	2
3	40	40 mV	0.4	2	4
4	60	60 mV	0.6	3	6
5	80	80 mV	0.8	4	8
6	100	100 mV	1.0	5	10

11.5.9.3. Status Outputs

The procedure below can be used to test the Status outputs.

1. Connect a cable jumper between the "-" pin and the "▽" pin on the status output connector.
2. Connect a 1000 Ω resistor between the +5 V and the pin for the status output that is being tested.

Table 11-8: Status Outputs Check Pin Out

PIN (left to right)	STATUS
1	System Ok
2	Conc Valid
3	High Range
4	Zero Cal
5	Span Cal
6	Diag Mode
7	Spare
8	Spare

3. Connect a voltmeter between the "-" pin and the pin of the output being tested (see Table 11-8).
4. Under the **DIAG → SIGNAL I/O** menu (see Section 6.9.2), scroll through the inputs and outputs until you get to the output in question. Alternately turn on and off the output noting the voltage on the voltmeter, it should vary between 0 volts for ON and 5 volts for OFF.

11.5.9.4. Control Inputs

The control input bits can be tested by the following procedure:

1. Connect a jumper from the +5 V pin on the STATUS connector to the +5 V on the CONTROL IN connector.
2. Connect a second jumper from the '-' pin on the STATUS connector to the A pin on the CONTROL IN connector. The instrument should switch from **SAMPLE** mode to **ZERO CAL R** mode.
3. Connect a second jumper from the '-' pin on the STATUS connector to the B pin on the CONTROL IN connector. The instrument should switch from **SAMPLE** mode to **SPAN CAL R** mode.

In each case, the 6400E should return to SAMPLE mode when the jumper is removed.

11.5.10. CPU

There are two major types of CPU board failures, a complete failure and a failure associated with the Disk-On-Chip (DOC). If either of these failures occur, contact the factory.

- For complete failures, assuming that the power supplies are operating properly and the wiring is intact, the CPU is faulty if on power-on:
 - The watchdog LED on the motherboard is not flashing, either the motherboard or the CPU is faulty
 - There is no activity from the primary RS-232 port (COM1) on the rear panel even if "<ret>" is pressed. Note that the RS-232 port has programmable baud rates from 200 to 115200 baud. Since the CPU board remembers the programmed baud rate even when power is off, this means that there is no default baud rate for the port when the instrument boots up, the rate will be whatever it was last programmed to be. In some cases, configuration memory might be corrupted, and the baud rate could be a random unrelated value. For these reasons, it is best to test all possible baud rates when performing this test. See the RS-2323 Communication section below, for more details regarding port configuration.

In some rare circumstances, this failure may be caused by a bad IC on the motherboard, specifically U57, the large, 44 pin device on the lower right hand side of the board. If this is true, removing U57 from its socket will allow the instrument to start up but the measurements will be invalid.

- If the analyzer stops during initialization (the vacuum fluorescent display shows some text), it is likely that the DOC, the firmware or the configuration and data files have been corrupted.

11.5.11. RS-232 COMMUNICATION

11.5.11.1. General RS-232 Troubleshooting

Teledyne Instruments analyzers use the RS-232 protocol as the standard, serial communications protocol. RS-232 is a versatile standard, which has been used for many years but, at times, is difficult to configure. Teledyne Instruments conforms to the standard pin assignments in the implementation of RS-232. Problems with RS-232 connections usually center around 4 general areas:

- Incorrect cabling and connectors. This is the most common problem. See Figure 6-8 for connector and pin-out information and Section 6.10.3.
- The communications (baud) rate and protocol parameters are incorrectly configured.
 - See Section 6.10.9 on how to set the baud rate.
 - The COM port communications mode is set incorrectly (see Section 6.10.8).
- If a modem is used, additional configuration and wiring rules must be observed. See Section 6.12.2.6.
- Incorrect setting of the DTE - DCE Switch is set correctly See Section 6.10.5.

11.5.11.2. Modem or Terminal Operation

These are the general steps for troubleshooting problems with a modem connected to a Teledyne Instruments analyzer.

- Check cables for proper connection to the modem, terminal or computer.
- Check the correct position of the DTE/DCE as described in Section 6.10.5.
- Check the correct setup command (see Section 6.12.2.6.)
- Verify that the Ready to Send (RTS) signal is at logic high. The 6400E sets pin 7 (RTS) to greater than 3 volts to enable modem transmission.
- Make sure the baud rate, word length, and stop bit settings between modem and analyzer match, see Section 6.12.2.6. and Section 6.10.
- Use the RS-232 test function to send "w" characters to the modem, terminal or computer; See Section 6.10.10.
- Get your terminal, modem or computer to transmit data to the analyzer (holding down the space bar is one way). The green LED on the rear panel should flicker as the instrument is receiving data.
- Make sure that the communications software is functioning properly.

Further help with serial communications is available in a separate manual "RS-232 Manual", Teledyne Instruments part number 013500000, available online at <http://www.Teledyne-ai.com/manuals/>.

11.5.12. SHUTTER SYSTEM

To check the functionality of the UV light Shutter by manually activating it.

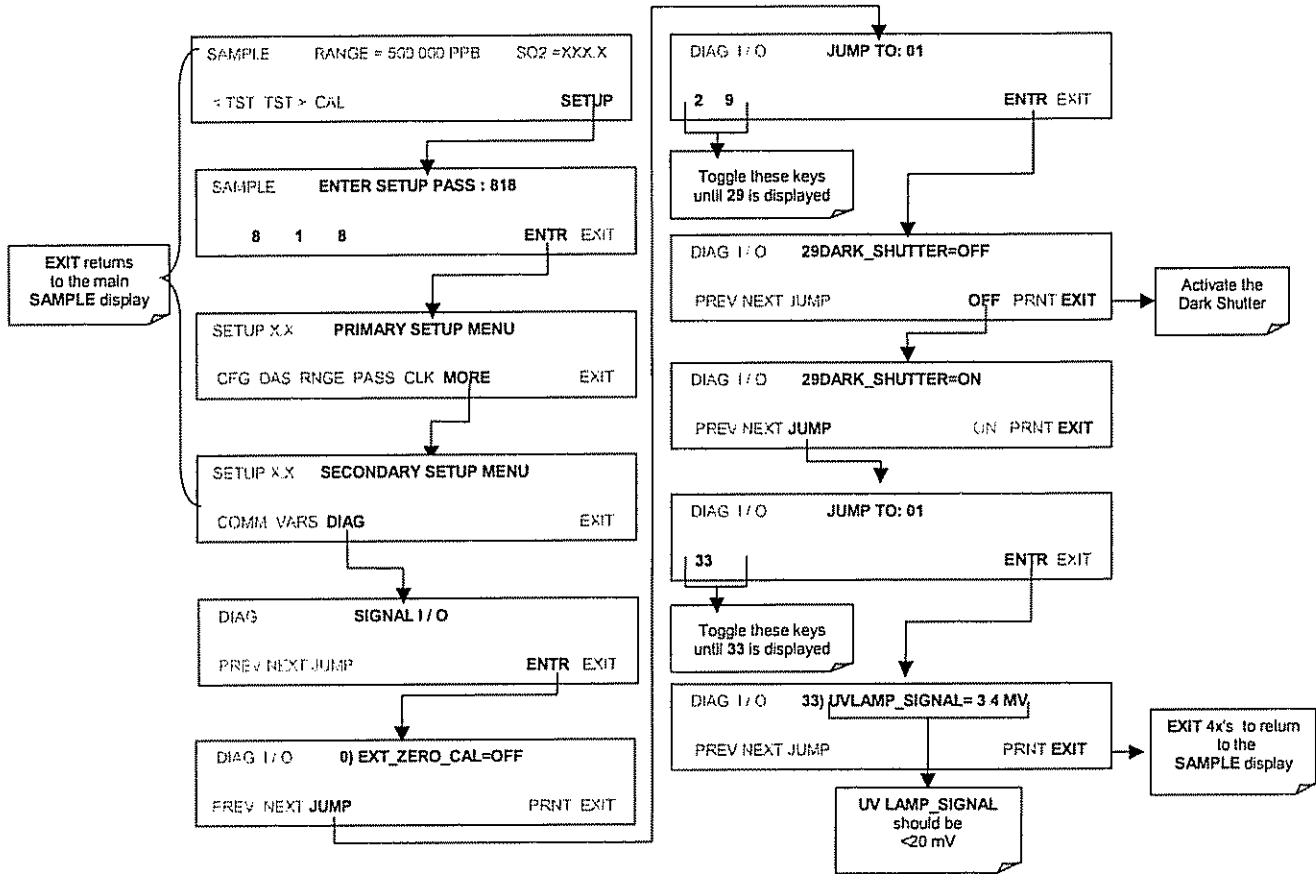

11.5.13. PMT SENSOR

The photo multiplier tube detects the light emitted by the UV excited fluorescence of SO₂. It has a gain of about 500000 to 1000000. It is not possible to test the detector outside of the instrument in the field. The best way to determine if the PMT is working properly is by using the optical test (**O**TEST), which is described in Section 6.9.5. The basic method to diagnose a PMT fault is to eliminate the other components using **E**TEST, **O**TEST and specific tests for other sub-assemblies.

11.5.14. PMT PREAMPLIFIER BOARD

To check the correct operation of the preamplifier board, we suggest the technician carry out the electrical and optical tests described in 6.8.5. and 6.8.6.

- If the **E**TEST fails, the preamplifier board may be faulty.

11.5.15. PMT TEMPERATURE CONTROL PCA

The TEC control printed circuit assembly is located on the sensor housing assembly, under the slanted shroud, next to the cooling fins and directly above the cooling fan.

- If the red LED located on the top edge of this assembly is not glowing the control circuit is not receiving power.
- Check the analyzers power supply, the Relay boards power distribution circuitry and the and the wiring connecting them to the PMT temperature control PCA.

11.5.15.1. TEC Control Test Points

Four test points are also located at the top of this assembly they are numbered left to right start with the T1 point immediately to the right of the power status LED. These test points provide information regarding the functioning of the control circuit.

- To determine the current running through the control circuit, measure the voltage between T1 and T2. Multiply that voltage by 10.
- To determine the drive voltage being supplied by the control circuit to the TEC, measure the voltage between T2 and T3.
 - If this voltage is zero, the TEC circuitry is most likely open.
 - If the voltage between T2 and T3 = 0 VDC and the voltage measured between T1 and T2 = 0 VDC there is most likely an open circuit or failed op amp on control PCA itself
 - If the voltage between T2 and T3 = 0 VDC and the voltage measured between T1 to T2 is some voltage other than 0 VDC, the TEC is most likely shorted
- T4 is tied directly to ground. To determine the absolute voltage on any one of the other test points make a measurement between that test point and T4.

11.5.16. HIGH VOLTAGE POWER SUPPLY

The HVPS is located in the interior of the sensor module and is plugged into the PMT tube (see Figure 10-14). It requires 2 voltage inputs. The first is +15 which powers the supply. The second is the programming voltage which is generated on the Preamp Board. This power supply is unlike a traditional PMT HVPS. It is like having 10 independent power supplies, one to each pin of the PMT. The test procedure below allows you to test each supply.

1. Check the **HVPS** test function via the front panel Turn off the instrument and record the reading level. Adjustment of the HVPS output level is covered in the hardware calibration procedure in Section 11.6.3.8.
2. Turn off the instrument.
3. Remove the cover and disconnect the 2 connectors at the front of the PMT housing.
4. Remove the end plate from the PMT housing.
5. Remove the HVPS/PMT assembly from the cold block inside the sensor. Un-plug the PMT.

6. Re-connect the 7 pin connector to the Sensor end cap, and power-up the instrument.
7. Check the voltages between the pairs of pins listed in Table 11-9. The result for each pair should be equal and approximately 10% of the reading level recorded in Step 1.

Table 11-9: Example of HVPS Power Supply Outputs

If HVPS reading = 700 VDC	
PIN PAIR	NOMINAL READING
1 → 2	70 VDC
2 → 3	70 VDC
3 → 4	70 VDC
4 → 5	70 VDC
5 → 6	70 VDC
6 → 7	70 VDC
7 → 8	70 VDC

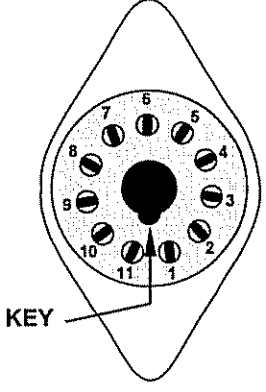

8. Turn off the instrument power, and re-connect the PMT tube, then re-assemble the sensor.

If any faults are found in the test, the HVPS must be replaced. There are no user serviceable parts inside the HVPS.

11.5.17. PNEUMATIC SENSOR ASSEMBLY

The pressure/flow sensor circuit board, located behind the sensor assembly, can be checked with a voltmeter using the following procedure, which assumes that the wiring is intact and that the motherboard and the power supplies are operating properly.

- Measure the voltage across TP1 and TP2, it should be 10.0 ± 0.25 V. If not, the board may be faulty.
- Measure the voltage across capacitor C2, it should be 5.0 ± 0.25 V. If not, the board may be faulty.

11.5.17.1. Sample Pressure

Measure the voltage across test points TP1 and TP4. With the sample pump disconnected or turned off, this voltage should be 4500 ± 250 mV. With the pump running, it should be about 0.2 V less as the sample pressure drops by about 1 in-Hg-A from ambient pressure. If this voltage is significantly different, the pressure transducer S2 or the board may be faulty. A leak in the sample system to vacuum may also cause this voltage to be between about 0.6 and 4.5. Make sure that the front panel reading of the sample pressure is at about 1 in-Hg-A less than ambient pressure.

11.5.18. IZS OPTION

The zero/span valves and IZS options need to be enabled in the software (contact the factory on how to do this). See Figure 5-2 and 5-3 for a flow diagram with zero/span valve or IZS option.

- Check for the physical presence of the valves or the IZS option.
- Check that a working perm-tube is installed in the IZS oven assembly.
- Check front panel for correct software configuration. When the instrument is in SAMPLE mode, the front panel display should show **CALS** and **CALZ** buttons in the second line of the display. The presence of the buttons indicates that the option has been enabled in software. In addition, the IZS option is enabled if the TEST functions show a parameter named IZS TEMP.

The IZS option is heated with a proportional heater circuit and the temperature is maintained at $50^{\circ}\text{C} \pm 1^{\circ}$. Check the **IZS TEMP** function via front panel display (see Section 6.2.1) and the **IZS_TEMP** signal voltage using the **SIGNAL I/O** function under the **DIAG** Menu (see Section 6.9.2).

- At 50°C , the temperature signal from the IZS thermistor should be around 2500 mV.

11.5.19. BOX TEMPERATURE

The box temperature sensor (thermistor) is mounted on the motherboard at the bottom, right corner of the CPU board when looking at it from the front. It cannot be disconnected to check its resistance. Box temperature will vary with, but will always read about 5°C higher than, ambient (room) temperature because of the internal heating zones sample chamber and other devices.

To check the box temperature functionality, we recommend to check the **BOX_TEMP** signal voltage using the **SIGNAL I/O** function under the **DIAG** Menu (see Section 6.9.2).

- At about 30°C (5° above typical room temperature), the signal should be around 1500 mV. We recommend to use a certified or calibrated external thermometer / temperature sensor to verify the accuracy of the box temperature.

11.5.20. PMT TEMPERATURE

PMT temperature should be low and constant. It is more important that this temperature is maintained constant than it is to maintain it low. The PMT cooler uses a Peltier, thermo-electric element powered by 12 VDC from the switching power supply PS2. The temperature is controlled by a proportional temperature controller located on the preamplifier board. Voltages applied to the cooler element vary from ± 0.1 to ± 12 VDC. The temperature set point (hard-wired into the preamplifier board) will vary by about $\pm 1^{\circ}\text{C}$ due to component tolerances. The actual temperature will be maintained to within 0.1°C around that set point.

On power-up of the analyzer, the front panel enables the user to watch that temperature drop from about ambient temperature down to its set point of $6-8^{\circ}\text{C}$.

- If the temperature fails to drop after 20 minutes, there is a problem in the cooler circuit.
- If the control circuit on the preamplifier board is faulty, a temperature of -1°C is reported.

11.6. REPAIR PROCEDURES

This section contains some procedures that may need to be performed when a major component of the analyzer requires repair or replacement.

NOTE

Servicing of circuit components requires electrostatic discharge protection, i.e. ESD grounding straps, mats and containers. Failure to use ESD protection when working with electronic assemblies will void the instrument warranty.

See Chapter 12 for more information on preventing ESD damage.

11.6.1. DISK-ON-CHIP REPLACEMENT

Replacing the Disk-on-Chip (DOC) will cause all of the instrument configuration parameters to be lost unless the replacement chip carries the exact same firmware version. If the analyzer is equipped with at least one EEPROM flash chip, the configuration settings are stored in a backup file on the EEPROM. It is recommended to document all analyzer parameters that may have been changed, such as calibration, range, auto-cal, analog output, serial port and other settings before replacing the chip.

1. Turn off power to the instrument, fold down the rear panel by loosening the mounting screws.
2. When looking at the electronic circuits from the back of the analyzer, locate the Disk-on-Chip in the right-most socket of the CPU board.
 - The chip should carry a label with firmware revision, date and initials of the programmer.
3. Remove the IC with a dedicated IC removal tool or by gently prying it up from the socket. Do not bend the connector pins.
4. Install the new Disk-on-Chip, making sure the notch at the end of the chip matches the notch in the socket.
 - It may be necessary to straighten the pins somewhat to fit them into the socket. Press the chip all the way in.
5. Close the rear panel and turn on power to the machine.

Generally, all of the setup information will need to be re-entered, unless the firmware revision has not changed and the analyzer is equipped and properly configured with an EEPROM chip. Whenever changing the version of installed software, the memory must be reset. Failure to ensure that memory is reset can cause the analyzer to malfunction, and invalidate measurements. Note especially that the A/D converter must be re-calibrated, and all information collected in step 1 above must be re-entered before the instrument will function correctly.

11.6.2. FLASH CHIP REPLACEMENT OR UPGRADE

The 6400E CPU board can accommodate up to two EEPROM flash chips. The standard configuration is one chip with 64 kb of storage capacity, which is used to store a backup of the analyzer configuration as created during final checkout at the factory. Replacing this chip will erase that backup configuration, which will be replaced with a new copy when restarting the analyzer. However, if the firmware and/or the DOC is changed at the same time, all analyzer configuration settings and IDAS data will be lost. In this case, refer to the previous section on how to back up your settings.

1. Turn off power to the instrument, fold down the rear panel by loosening the mounting screws.
2. When looking at the electronic circuits from the back of the analyzer, locate the EEPROM chip in the left-most socket of the CPU board. The chip is square with one corner cut off, the socket is shaped accordingly.
3. Remove the old chip by using a special tool or gently pry the chip out using a very fine screwdriver. Make sure not to bend or destroy any of the contacts of the socket.
4. Reinstall the new or additional EEPROM chip, making sure the cut-off edge matches that of the socket. Press the chip symmetrically and straight all the way in.
5. Close the rear panel and turn on power to the machine.

11.6.3. SENSOR MODULE REPAIR & CLEANING

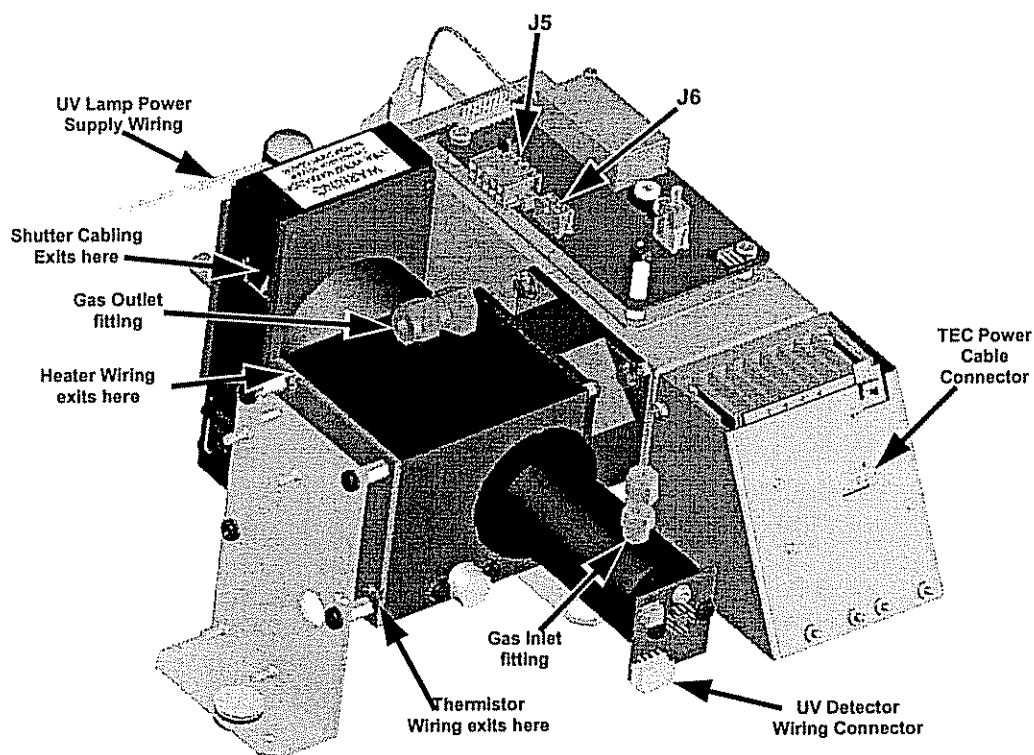

Figure 11-7: Sensor Module Wiring and Pneumatic Fittings

NOTE:

After any repair or service has been performed on the sensor module, the 6400E should be allowed to warm up for 60 minutes.

Always perform a leak check (See Section 11.5.1) and calibrate the analyzer (see Chapter 7) before placing it back in service.

11.6.3.1. Removing and Reinstalling the Sensor Module:

Several of the procedures in this section either require the sensor module to be removed from the instrument or are easier to perform if it has been removed.

To remove the Sensor Module:

1. Turn off the instrument power.
2. Open the top cover of the instrument:
 - Remove the set screw located in the top, center of the rear panel
 - Remove the screws fastening the top cover to the unit (four per side).
 - Lift the cover straight up.
3. Disconnect the sensor module pneumatic lines (see Figure 11-7)
 - Gas inlet line: 1/8" black Teflon[®] line with stainless steel fitting.
 - Gas outlet line: 1/4" black Teflon[®] line with brass fitting.
4. Disconnect all electrical wiring to the Sensor Module:
 - UV lamp power supply wiring.
 - Shutter cabling.
 - Reaction cell thermistor wiring (yellow).
 - Reaction cell heater wiring (red).
 - UV detector wiring.
 - TEC power cable.
 - PMT wiring (connectors J5 & J6 on the PMT preamplifier PCA).
5. Remove the three sensor module mounting screws.

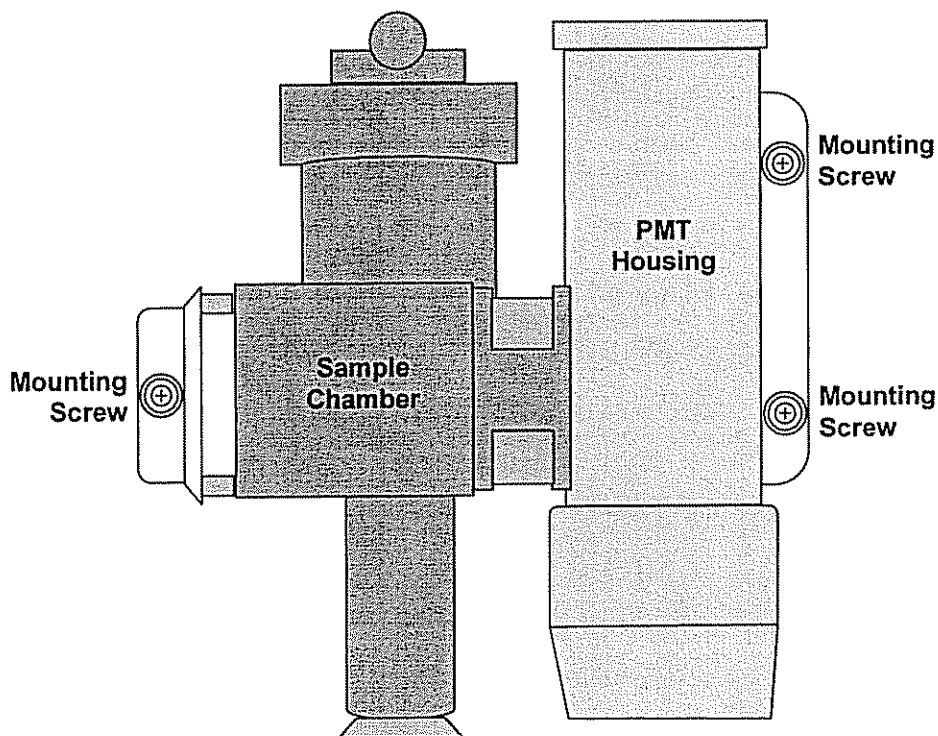

Figure 11-8: Sensor Module Mounting Screws

Follow the above steps in reverse order to reinstall the sensor module.

11.6.3.2. Cleaning the Sample chamber

NOTE:

The sample chamber should only be opened or cleaned on instructions from the Teledyne Instruments customer service department.

Be careful not to leave thumbprints on the interior of the sample chamber. The various oils that make up fingerprints fluoresce brightly under UV light and will significantly affect the accuracy of the analyzer's SO₂ measurement)

To clean the sample chamber:

1. Remove the sensor module as described in Section 11.6.3.1
2. Remove the sample chamber mounting bracket by unscrewing the four bracket screws.

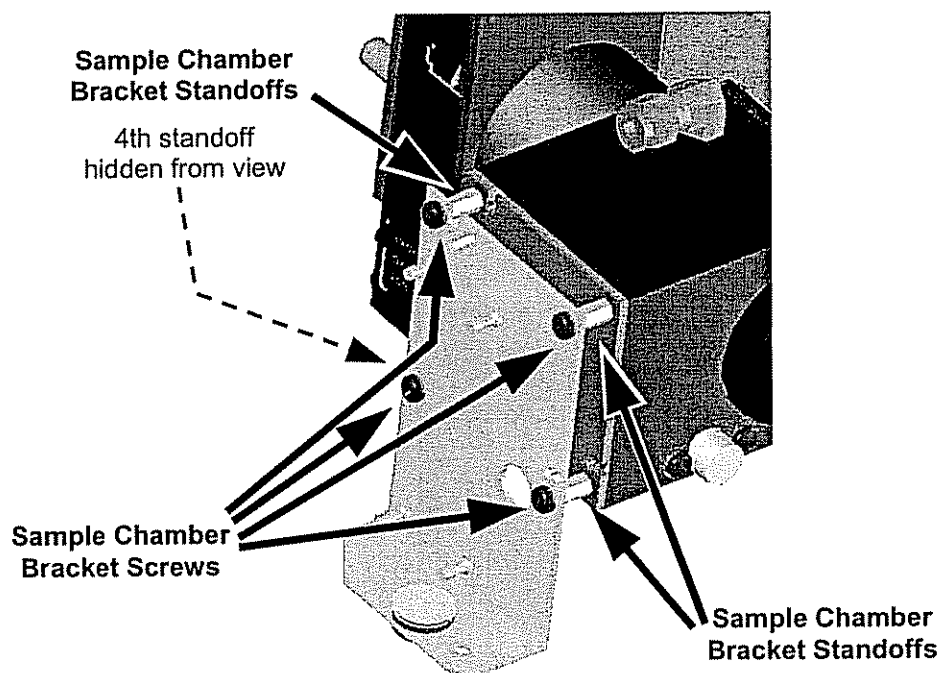

Figure 11-9: Sample Chamber Mounting Bracket

3. Unscrew the 4 hexagonal standoffs
4. Gently remove the chamber cover.
5. Using a lint-free cloth dampened with distilled water, wipe the inside surface of the chamber and the chamber cover.
6. Dry the chamber surfaces with a 2nd lint-free cloth.
7. Re-assemble the chamber and re-install the sensor module.

11.6.3.3. Cleaning the PMT Lens & PMT filter

NOTE:

The sample chamber should only be opened or cleaned on instructions from the Teledyne Instruments customer service department.

Be careful not to leave thumbprints on the interior of the sample chamber. The various oils that make up fingerprints fluoresce brightly under UV light and will significantly affect the accuracy of the analyzer's SO₂ measurement)

To clean the PMT Lens and filter:

1. Remove the sensor module as described in Section 11.6.3.1

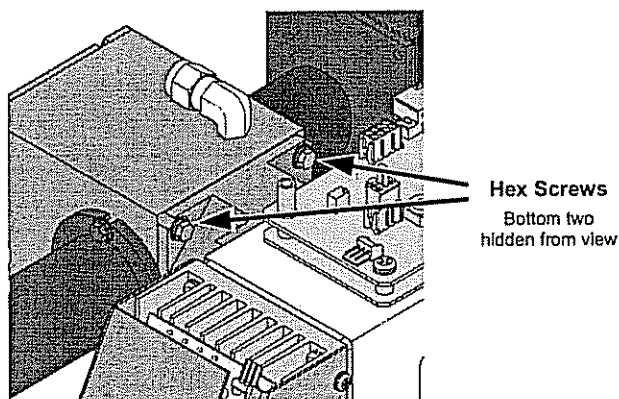

Figure 11-10: Hex Screw Between Lens Housing and Sample chamber

2. Remove the sample chamber from the PMT lens and filter housing by unscrewing the 4 hex screws that fasten the chamber to the housing.
3. Remove the four lens cover screws.

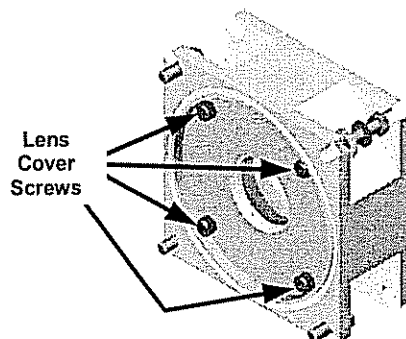

Figure 11-11: UV Lens Housing / Filter Housing

4. Remove the lens/filter cover.
5. Carefully remove the PMT lens and set it aside on soft, lint-free cloth.

6. Remove the 3-piece, lens/filter spacer.
7. Carefully remove the PMT filter and set it aside on soft, lint-free cloth.

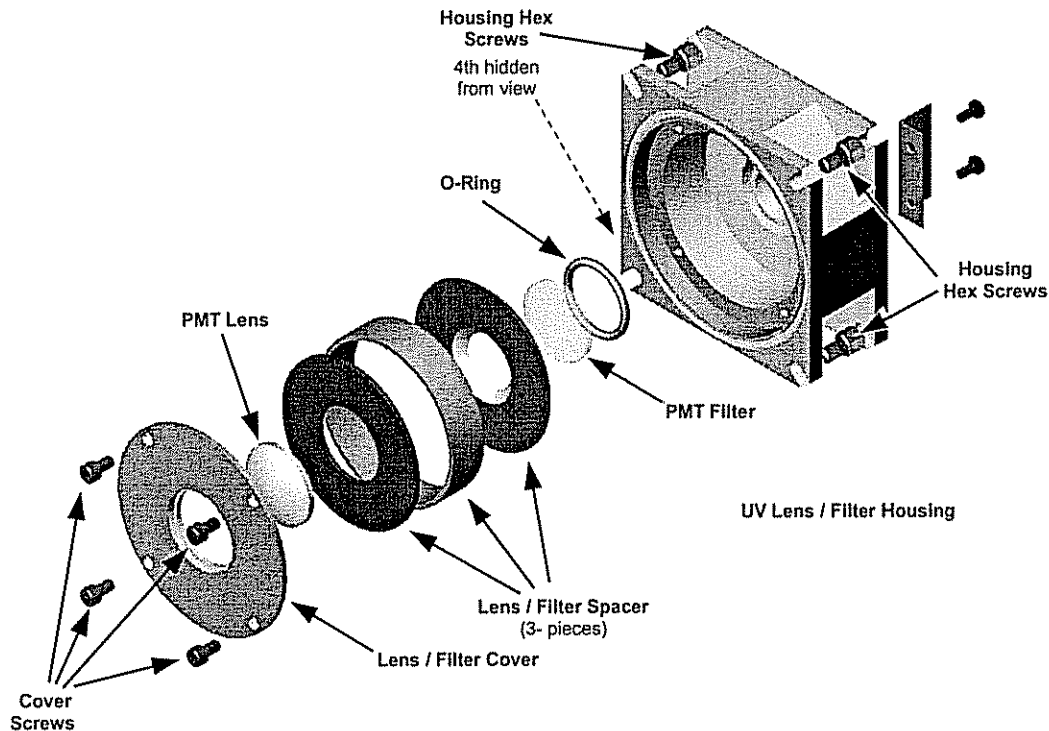

Figure 11-12: PMT UV Filter Housing Disassembled

8. Using a lint-free cloth dampened with distilled water, clean the lens, the filter and all of the housing assembly mechanical parts
9. Dry everything with a 2nd lint-free cloth.
10. Reassemble the lens/filter housing (see Figure 11-12).
11. Reattach the lens / filter housing to the sample chamber.
12. Reattach the sample chamber to the PMT housing.
13. Reinstall the sensor module into the 6400E.
14. Close the instrument.
15. Turn the 6400E on and let it warm up for 60 minutes.
16. Perform a leak check (See Section 11.5.1).
17. Calibrate the analyzer (see Chapter 7).

11.6.3.4. Replacing the UV filter/lens

NOTE

Be careful not to leave thumbprints on the interior of the sample chamber. The various oils that make up fingerprints fluoresce brightly under UV light and will significantly affect the accuracy of the analyzer's SO₂ measurement)

1. Turn off the instrument's power and remove the power cord from the instrument.
2. Unplug J4 connector from the motherboard to allow tool access.
 - Alternatively, remove the sensor module as described in Section 11.6.3.1
3. Remove 4 screws from the shutter cover (see figure 11-13) and remove the cover .
4. Remove 4 screws from the UV filter retainer.

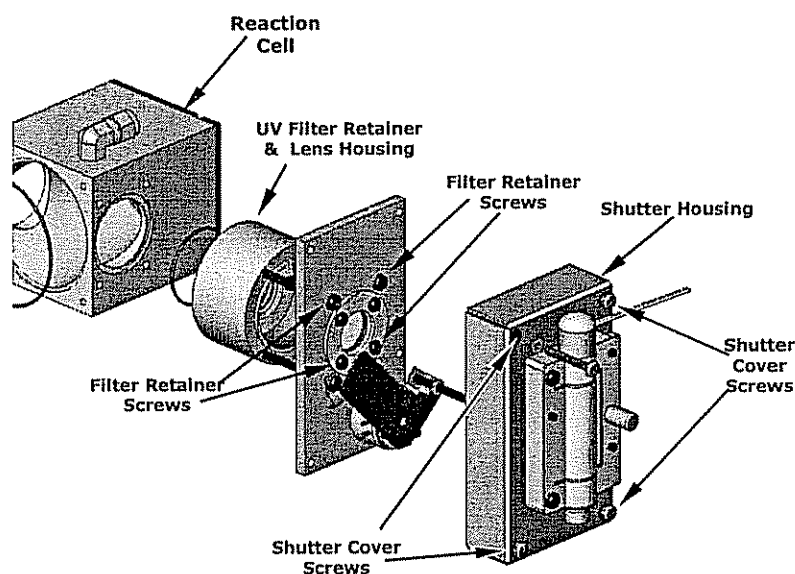

Figure 11-13: Disassembling the Shutter Assembly

5. Carefully remove the UV filter.
6. Install the UV filter.
 - Handle carefully and never touch the filter's surface.
 - UV filter's wider ring side should be facing out.
7. Install UV filter retainer and tighten screws.
8. Install the shutter cover and minifit connector. Tighten 4 shutter cover screws.
9. Reinstall the sensor module and Plug J4 connector into the motherboard

11.6.3.5. Adjusting the UV Lamp (*Peaking the Lamp*)

There are three ways in which ambient conditions can effect the UV Lamp output and therefore the accuracy of the SO₂ concentration measurement. These are:

Line Voltage Change: UV lamp energy is directly proportional to the line voltage. This can be avoided by installing adequate AC Line conditioning equipment such as a UPS/surge suppressor.

Lamp Aging - Over a period of months, the UV energy will show a downward trend, usually 30% in the first 90 days, and then a slower rate, until the end of useful life of the lamp. Periodically running the UV lamp calibration routine (see Section 6.9.7) will compensate for this until the lamp output becomes too low to function at all.

Lamp Positioning - The UV output level of the lamp is not even across the entire length of the lamp. Some portions of the lamp shine slightly more brightly than others. At the factory the position of the UV lamp is adjusted to optimize the amount of UV light shining through the UV filter/lens and into the reaction cell. Changes to the physical alignment of the lamp can affect the analyzers ability to accurately measure SO₂.

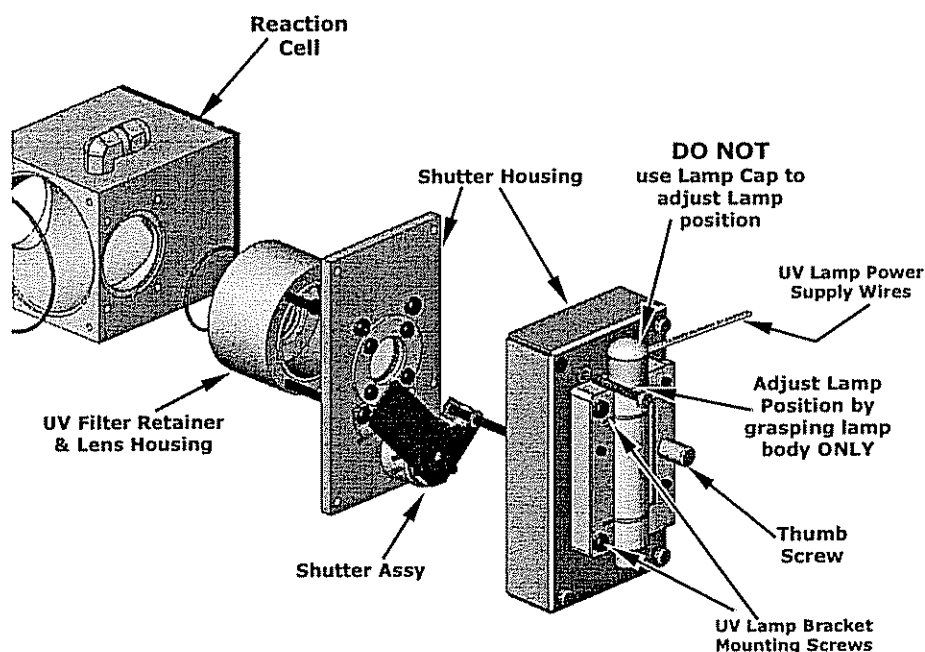

Figure 11-14: Shutter Assembly - Exploded View



CAUTION:

ALWAYS wear UV-Protective, Safety Glasses when working with the UV Lamp Assembly

1. Set the analyzer display to show the signal I/O function, **UVLAMP_SIGNAL** (see Section 11.1.3). **UVLAMP_SIGNAL** is function 33.
2. Slightly loosen the large brass thumbscrew located on the shutter housing (see Figure 11-14) so that the lamp can be moved.
3. While watching the **UVLAMP_SIGNAL** reading, slowly rotate the lamp or move it back and forth vertically until the **UVLAMP_SIGNAL** reading is at its maximum.

NOTE:

DO NOT grasp the UV lamp by its cap when changing its position (see Figure 11-14). Always grasp the main body of the lamp.

4. Compare the **UVLAMP_SIGNAL** reading to the information in Table 11.10 and follow the instructions there.

Table 11-10: Example of HVPS Power Supply Outputs

UVLAMP_SIGNAL	ACTION TO BE TAKEN
3500mV±200mV.	No Action Required
> 4900mV at any time.	Adjust the UV reference detector potentiometer (see Figure 11.15) until UVLAMP_SIGNAL reads approximately 3600mV before continuing to adjust the lamp position.
>3700mV or < 3300mV	Adjust the UV reference detector potentiometer (see Figure 11.15) until UVLAMP_SIGNAL reads as close to 3500mV as possible.
.< 600mV	Replace the lamp.

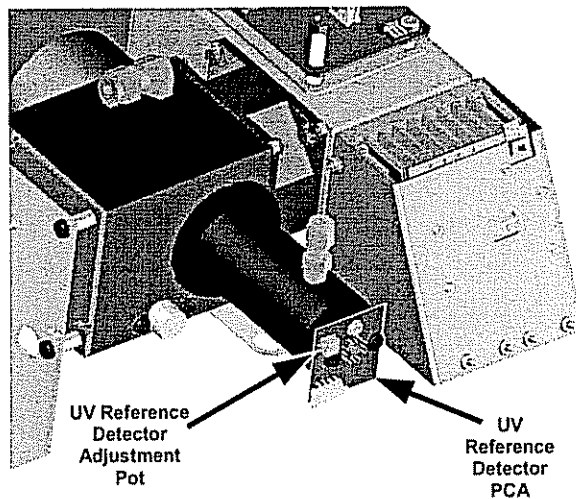

Figure 11-15: Location of UV Reference Detector Potentiometer

5. Finger tighten the thumbscrew.

NOTE:

DO NOT over-tighten the thumbscrew.

11.6.3.6. Replacing the UV Lamp

1. Turn off the analyzer.
2. Disconnect the UV lamp from its power supply.
 - You can find the power supply connector by following the two, white UV Lamp power supply wires from the lamp to the power supply.
3. Loosen, but do not remove the two UV lamp bracket screws and the large brass thumbscrew located on the shutter housing (see Figure 11-14) so that the lamp can be moved.

NOTE:

**DO NOT grasp the UV lamp by its cap when changing its position (see Figure 11-14).
Always grasp the main body of the lamp.**

4. Remove the UV Lamp by pulling it straight up.
5. Insert the new UV lamp into the bracket.
6. Tighten the two UV lamp bracket screws, but leave the brass thumb screw un-tightened.
7. Connect the new UV lamp to the power supply.
8. Turn the instrument on and perform the UV adjustment procedure as defined in section 11.6.3.5
9. Finger tighten the thumbscrew.

NOTE:

DO NOT over-tighten the thumbscrew.

10. Perform a lamp calibration procedure (see Section 6.9.7) and a zero point and span point calibration (see Chapter 7).

11.6.3.7. Replacing the PMT, HVPS or TEC

The PMT should last for the lifetime of the analyzer. However, in some cases, the high voltage power supply (HVPS) or the thermo-electric cooler (TEC) may fail. To replace the PMT, the HVPS or the TEC:

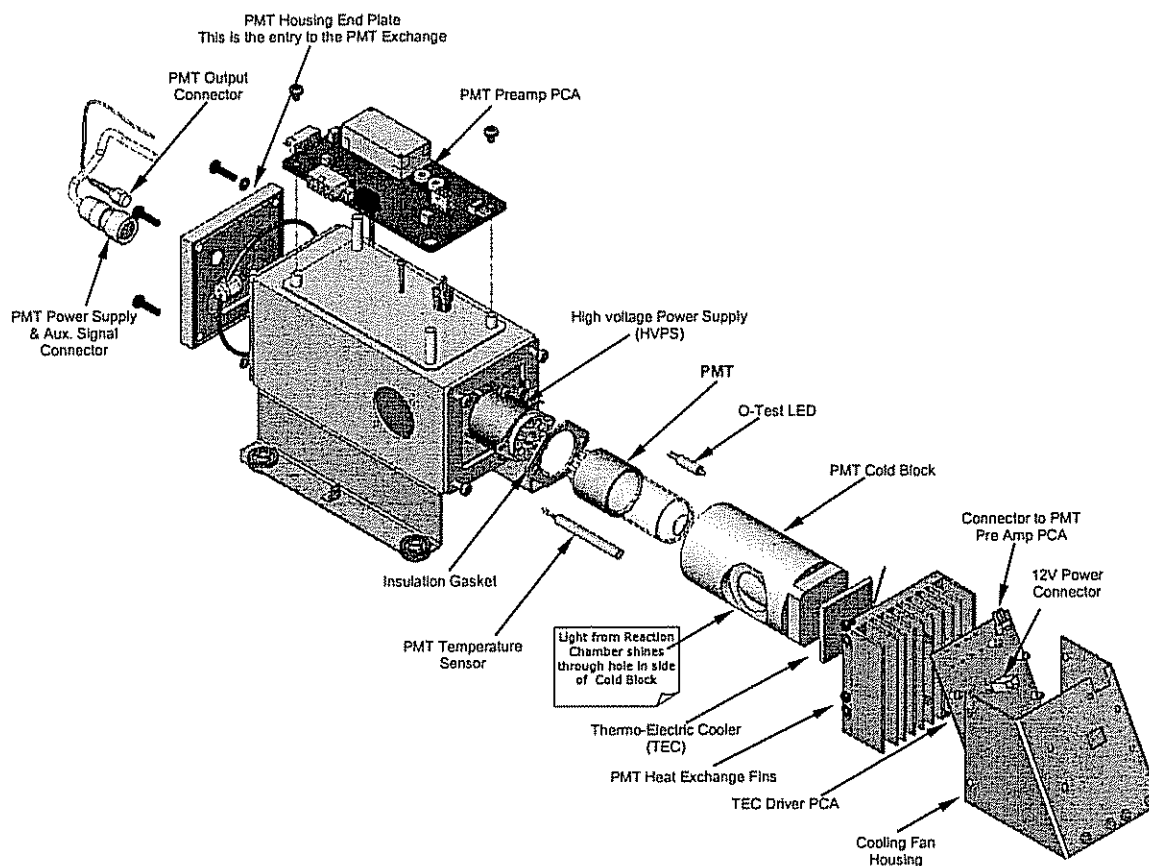

Figure 11-16: PMT Assembly - Exploded View

1. Remove the sensor module as described in Section 11.6.3.5
2. Remove the entire sensor module assembly from the.
3. Remove the reaction cell assembly.
4. Remove the two connectors on the PMT housing end plate facing towards the front panel.
5. Remove the end plate itself (4 screws with plastic washers). R
6. Remove the two desiccant bags inside the PMT housing.
7. Along with the plate, slide out the OPTIC TEST LED and the thermistor that measures the PMT temperature.
 - Both may be coated with a white, thermal conducting paste. Do not contaminate the inside of the housing or the PMT tube with this grease.

8. Unscrew the PMT assembly. It is held to the cold block by two plastic screws.
 - Because the threads of the plastic screws are easily damaged it is highly recommended to use new screws when reassembling the unit.
9. Carefully take out the assembly consisting of the HVPS, the gasket and the PMT.
10. Change the PMT or the HVPS or both, clean the PMT glass tube with a clean, anti-static wipe and **DO NOT TOUCH** it after cleaning.
11. If the cold block or TEC is to be changed disconnect the TEC driver board from the preamplifier board.
 - Remove the cooler fan duct (4 screws on its side) including the driver board.
 - Disconnect the driver board from the TEC and set the sub-assembly aside.
 - Remove the end plate with the cooling fins (4 screws) and slide out the PMT cold block assembly, which contains the TEC.
 - Unscrew the TEC from the cooling fins and the cold block and replace it with a new unit.
12. Re-assemble the TEC subassembly in reverse order.

CAUTION

The thermo-electric cooler needs to be mounted flat to the heat sink. If there is any significant gap, the TEC might burn out. Make sure to apply heat sink paste before mounting it and tighten the screws evenly and cross-wise.

- Make sure to use thermal grease between TEC and cooling fins as well as between TEC and cold block.
 - Align the side opening in the cold block with the hole in the PMT housing where the sample Chamber attaches.
 - Evenly tighten the long mounting screws for good thermal conductivity.
13. Re-insert the TEC subassembly. Make sure that the O-ring is placed properly and the assembly is tightened evenly.
 14. Re-insert the PMT/HVPS subassembly.
 - Don't forget the gasket between HVPS and PMT.
 - Use new plastic screws to mount the PMT assembly on the PMT cold block.
 15. Insert the LED and thermistor into the cold bloc.
 16. Insert new two desiccant bags.
 17. Carefully replace the end plate.
 - Make sure that the O-ring is properly in place. Improperly placed O-rings will cause leaks, which – in turn – cause moisture to condense on the inside of the cooler causing the HVPS to short out.

18. Reconnect the cables and the reaction cell
 - Be sure to tighten these screws evenly,
19. Replace the sensor assembly into the chassis and fasten with four screws and washers.
20. Perform a leak check the system
21. Power up the analyzer and verify the basic operation of the analyzer using the ETEST and OTEST features (see Section 6.9.5 & 6.9.6) or by measuring calibrated zero and span gases.
22. Allow the instrument to warm up for 60 minutes
23. Perform a PMT Hardware calibration (see Section 11.6.3.8)
24. Perform a zero point and span calibration (See Chapter 7)

11.6.3.8. PMT Hardware Calibration (**FACTORY CAL**)

The sensor module hardware calibration adjusts the slope of the PMT output when the Instruments slope and offset values are outside of the acceptable range and all other more obvious causes for this problem have been eliminated.

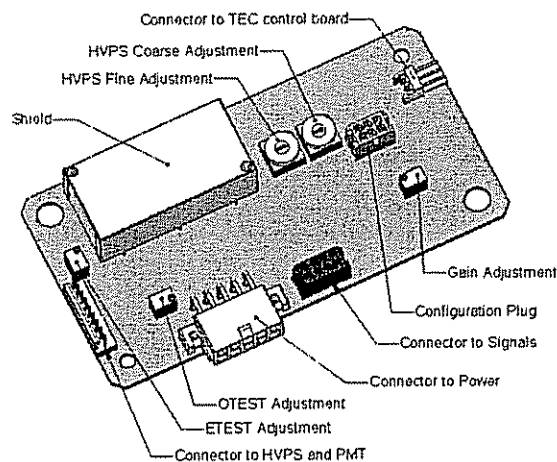

Figure 11-17: Pre-Amplifier Board Layout

1. Set the instrument reporting range type to **SNGL** (see Section 6.7.4)
2. Perform a zero-point calibration using zero air (see Chapter 7).
3. Let the instrument stabilize by allowing it to run for one hour.
4. Adjust the UV Lamp. (See Section 11.6.3.1)
5. Perform a **LAMP CALIBRATION** procedure (see Section 6.9.7).
6. Locate the Preamp board (see Figure 3-9).

7. Locate the Following Components On the Preamp board (see Figure 11-17):
 - HVPS coarse adjustment switch (Range 0-9, then A-F)
 - HVPS fine adjustment switch (Range 0-9, then A-F)
 - Gain adjustment potentiometer (Full scale is 10 to 12 turns).
8. Set the HVPS coarse adjustment to its minimum setting (0).
9. Set the HVPS fine adjustment switch to its maximum setting (F).
10. Turn the gain adjustment potentiometer clockwise to its maximum setting.
11. Set the front panel display to show **STABIL** (see Section 6.2.1)
12. Feed span gas into the analyzer.
13. Wait until the **STABIL** value is below 0.5 ppb,

NOTE

Use a span gas equal to 80% of the reporting range.

Example: for a reporting range of 500 ppb, use a span gas of 400 ppb.

14. scroll to the **OFFSET** function and record the value.
15. Scroll to the **NORM PMT** value.

NOTE

Do not overload the PMT by accidentally setting both adjustment switches to their maximum setting. This can cause permanent damage to the PMT.

16. Determine the target **NORM PMT** value according to the following formulas.
 - If the reporting range is set for $\leq 2,000$ ppb (the instrument will be using the 2,000 ppb physical range):

$$\text{Target NORM PMT} = (2 \times \text{span gas concentration}) + \text{OFFSET}$$
 - If the reporting range is set for $\geq 2,001$ ppb (the instrument will be using the 20,000 ppb physical range):

$$\text{Target NORM PMT} = (0.2 \times \text{span gas concentration}) + \text{OFFSET}$$

EXAMPLE: If the **OFFSET** is 33 mV, the Reporting Range is 500 ppb, the span gas should be 400 ppb and the calculation would be:

$$\begin{aligned} \text{Target NORM PMT} &= (2 \times 400) + 33 \text{ mV} \\ \text{Target NORM PMT} &= 833 \text{ mV} \end{aligned}$$

17. Set the HVPS coarse adjustment switch to the lowest setting that will give you more than the target NORM PMT signal from Step 16.
 - The coarse adjustment typically increments the **NORM PMT** signal in 100-300 mV steps.
18. Adjust the HVPS fine adjustment such that the **NORM PMT** value is at or just above the target NORM PMT signal from Step 16.
19. Continue adjusting the both the coarse and fine switches until **NORM PMT** is as close to (but not below) the target NORM PMT signal from Step 16.
20. Adjust gain adjustment potentiometer until the NORM PMT value is ± 10 mV of the target level from Step 16.
21. Perform span and zero-point calibrations (see Chapter 7) to normalize the sensor response to its new PMT sensitivity.
22. Review the slope and offset values, and compare them to the values in Table 7-5.

11.7. TECHNICAL ASSISTANCE

If this manual and its trouble-shooting / repair sections do not solve your problems, technical assistance may be obtained from Teledyne Analytical Instruments, Customer Service, 16830 Chestnut St., City of Industry, Ca. Phone: 626-934-1673. Email: tetci_customerservice@teledyne.com.

Before you contact customer service, fill out the problem report form in Appendix C.

USER NOTES:

12. A PRIMER ON ELECTRO-STATIC DISCHARGE

Teledyne Instruments considers the prevention of damage caused by the discharge of static electricity to be extremely important part of making sure that your analyzer continues to provide reliable service for a long time. This section describes how static electricity occurs, why it is so dangerous to electronic components and assemblies as well as how to prevent that damage from occurring.

12.1. HOW STATIC CHARGES ARE CREATED

Modern electronic devices such as the types used in the various electronic assemblies of your analyzer, are very small, require very little power and operate very quickly. Unfortunately the same characteristics that allow them to do these things also makes them very susceptible to damage from the discharge of static electricity. Controlling electrostatic discharge begins with understanding how electro-static charges occur in the first place.

Static electricity is the result of something called triboelectric charging which happens whenever the atoms of the surface layers of two materials rub against each other. As the atoms of the two surfaces move together and separate, some electrons from one surface are retained by the other.

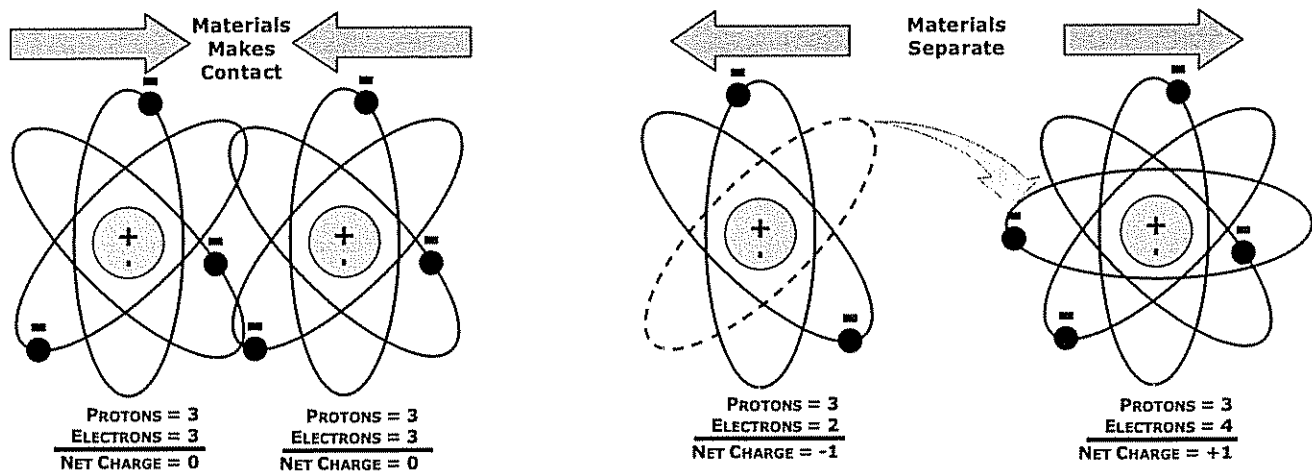

Figure 12-1: Triboelectric Charging

If one of the surfaces is a poor conductor or even a good conductor that is not grounded, the resulting positive or negative charge can not bleed off and becomes trapped in place, or static. The most common example of triboelectric charging happens when someone wearing leather or rubber soled shoes walks across a nylon carpet or linoleum tiled floor. With each step electrons change places and the resulting electro-static charge builds up, quickly reaching significant levels. Pushing an epoxy printed circuit board across a workbench, using a plastic handled screwdriver or even the constant jostling of Styrofoam™ pellets during shipment can also build hefty static charges

Table 12-1: Static Generation Voltages for Typical Activities

MEANS OF GENERATION	65-90% RH	10-25% RH
Walking across nylon carpet	1,500V	35,000V
Walking across vinyl tile	250V	12,000V
Worker at bench	100V	6,000V
Poly bag picked up from bench	1,200V	20,000V
Moving around in a chair padded with urethane foam	1,500V	18,000V

12.2. HOW ELECTRO-STATIC CHARGES CAUSE DAMAGE

Damage to components occurs when these static charges come in contact with an electronic device. Current flows as the charge moves along the conductive circuitry of the device and the typically very high voltage levels of the charge overheat the delicate traces of the integrated circuits, melting them or even vaporizing parts of them. When examined by microscope the damage caused by electro-static discharge looks a lot like tiny bomb craters littered across the landscape of the component's circuitry.

A quick comparison of the values in Table 12-1 with the those shown in the Table 12-2, listing device susceptibility levels, shows why *Semiconductor Reliability News* estimates that approximately 60% of device failures are the result of damage due to electro-static discharge.

Table 12-2: Sensitivity of Electronic Devices to Damage by ESD

DEVICE	DAMAGE SUSCEPTIBILITY VOLTAGE RANGE	
	DAMAGE BEGINS OCCURRING AT	CATASTROPHIC DAMAGE AT
MOSFET	10	100
VMOS	30	1800
NMOS	60	100
GaAsFET	60	2000
EPROM	100	100
JFET	140	7000
SAW	150	500
Op-AMP	190	2500
CMOS	200	3000
Schottky Diodes	300	2500
Film Resistors	300	3000
This Film Resistors	300	7000
ECL	500	500
SCR	500	1000
Schottky TTL	500	2500

Potentially damaging electro-static discharges can occur:

- Any time a charged surface (including the human body) discharges to a device. Even simple contact of a finger to the leads of an sensitive device or assembly can allow enough discharge to cause damage. A similar discharge can occur from a charged conductive object, such as a metallic tool or fixture.
- When static charges accumulated on a sensitive device discharges from the device to another surface such as packaging materials, work surfaces, machine surfaces or other device. In some cases, charged device discharges can be the most destructive.

A typical example of this is the simple act of installing an electronic assembly into the connector or wiring harness of the equipment in which it is to function. If the assembly is carrying a static charge, as it is connected to ground a discharge will occur.

- Whenever a sensitive device is moved into the field of an existing electro-static field, a charge may be induced on the device in effect discharging the field onto the device. If the device is then momentarily grounded while within the electrostatic field or removed from the region of the electrostatic field and grounded somewhere else, a second discharge will occur as the charge is transferred from the device to ground.

12.3. COMMON MYTHS ABOUT ESD DAMAGE

- **I didn't feel a shock so there was no electro-static discharge:** The human nervous system isn't able to feel a static discharge of less than 3500 volts. Most devices are damaged by discharge levels much lower than that.
- **I didn't touch it so there was no electro-static discharge:** Electro Static charges are fields whose lines of force can extend several inches or sometimes even feet away from the surface bearing the charge.
- **It still works so there was no damage:** Sometimes the damage caused by electro-static discharge can completely sever a circuit trace causing the device to fail immediately. More likely, the trace will be only partially occluded by the damage causing degraded performance of the device or worse, weakening the trace. This weakened circuit may seem to function fine for a short time, but even the very low voltage and current levels of the device's normal operating levels will eat away at the defect over time causing the device to fail well before its designed lifetime is reached.

These latent failures are often the most costly since the failure of the equipment in which the damaged device is installed causes down time, lost data, lost productivity, as well as possible failure and damage to other pieces of equipment or property.

- **Static Charges can't build up on a conductive surface:** There are two errors in this statement.

Conductive devices can build static charges if they are not grounded. The charge will be equalized across the entire device, but without access to earth ground, they are still trapped and can still build to high enough levels to cause damage when they are discharged.

A charge can be induced onto the conductive surface and/or discharge triggered in the presence of a charged field such as a large static charge clinging to the surface of a nylon jacket of someone walking up to a workbench.

- **As long as my analyzer is properly installed it is safe from damage caused by static discharges:** It is true that when properly installed the chassis ground of your analyzer is tied to earth ground and its electronic components are prevented from building static electric charges themselves. This does not, however, prevent discharges from static fields built up on other things, like you and your clothing, from discharging through the instrument and damaging it.

12.4. BASIC PRINCIPLES OF STATIC CONTROL

It is impossible to stop the creation of instantaneous static electric charges. It is not, however difficult to prevent those charges from building to dangerous levels or prevent damage due to electro-static discharge from occurring.

12.4.1. GENERAL RULES

Only handle or work on all electronic assemblies at a properly set up ESD station.

Setting up an ESD safe work station need not be complicated. A protective mat properly tied to ground and a wrist strap are all that is needed to create a basic anti-ESD workstation (see figure 12-2).

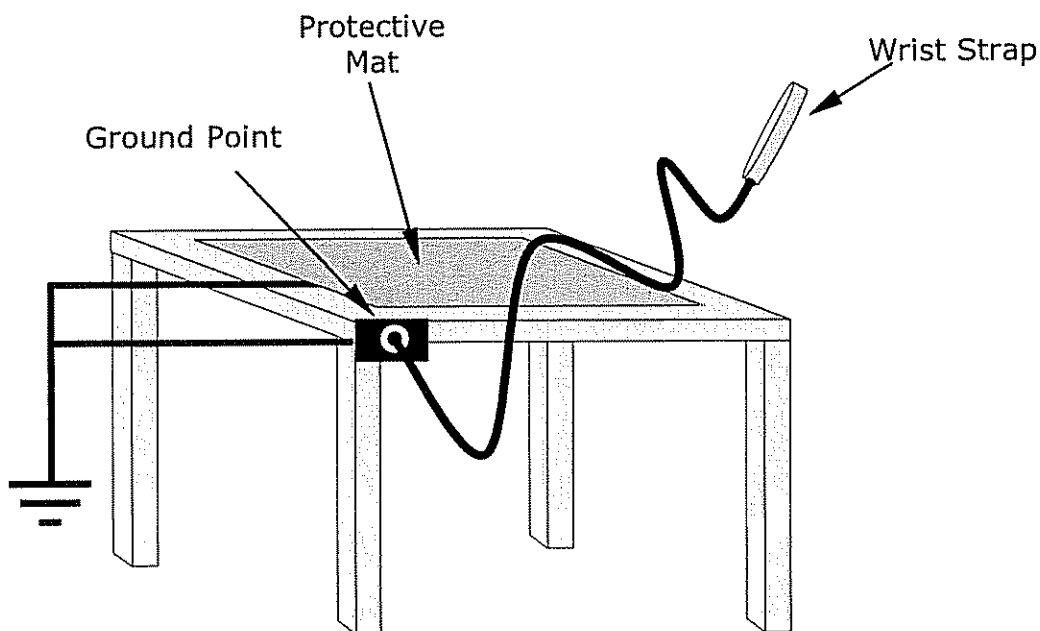

Figure 12-2: Basic anti-ESD Work Station

For technicians that work in the field, special lightweight and portable anti-ESD kits are available from most suppliers of ESD protection gear. These include everything needed to create a temporary anti-ESD work area anywhere.

- **Always wear an Anti-ESD wrist strap when working on the electronic assemblies of your analyzer.** An anti-ESD wrist strap keeps the person wearing it at or near the same potential as other grounded objects in the work area and allows static charges to dissipate before they can build to dangerous levels. Anti-ESD wrist straps terminated with alligator clips are available for use in work areas where there is no available grounded plug.

Also, anti-ESD wrist straps include a current limiting resistor (usually around one meg-ohm) that protects you should you accidentally short yourself to the instrument's power supply.

- **Simply touching a grounded piece of metal is insufficient.** While this may temporarily bleed off static charges present at the time, once you stop touching the grounded metal new static charges will immediately begin to re-build. In some conditions a charge large enough to damage a component can rebuild in just a few seconds.
- **Always store sensitive components and assemblies in anti-ESD storage bags or bins:** Even when you are not working on them, store all devices and assemblies in a closed anti-Static bag or bin. This will prevent induced charges from building up on the device or assembly and nearby static fields from discharging through the it.
- **Use metallic anti-ESD bags for storing and shipping ESD sensitive components and assemblies rather than pink-poly bags.** The famous, pink-poly bags are made of a plastic that is impregnated with a liquid (similar to liquid laundry detergent) which very slowly sweats onto the surface of the plastic creating a slightly conductive layer over the surface of the bag.

While this layer may equalizes any charges that occur across the whole bag, it does not prevent the build up of static charges. If laying on a conductive grounded surface, these bags will allow charges to bleed away but the very charges that build up on the surface of the bag itself can be transferred through the bag by induction onto the circuits of your ESD sensitive device. Also, the liquid impregnating the plastic is eventually used up after which the bag is as useless for preventing damage from ESD as any ordinary plastic bag.

Anti-Static bags made of plastic impregnated with metal (usually silvery in color) provide all of the charge equalizing abilities of the pink-poly bags but also, when properly sealed, create a Faraday cage that completely isolates the contents from discharges and the inductive transfer of static charges.

Storage bins made of plastic impregnated with carbon (usually black in color) are also excellent at dissipating static charges and isolating their contents from field effects and discharges.

- **Never use ordinary plastic adhesive tape near an ESD sensitive device or to close an anti-ESD bag.** The act of pulling a piece of standard plastic adhesive tape, such as Scotch[®] tape, from its roll will generate a static charge of several thousand or even tens of thousands of volts on the tape itself and an associated field effect that can discharge through or be induced upon items up to a foot away.

12.4.2. BASIC ANTI-ESD PROCEDURES FOR ANALYZER REPAIR AND MAINTENANCE

12.4.2.1. Working at the Instrument Rack

When working on the analyzer while it is in the instrument rack and plugged into a properly grounded power supply

1. Attach your anti-ESD wrist strap to ground before doing anything else.
 - Use a wrist strap terminated with an alligator clip and attach it to a bare metal portion of the instrument chassis. This will safely connect you to the same ground level to which the instrument and all of its components are connected.
2. Pause for a second or two to allow any static charges to bleed away.
3. Open the casing of the analyzer and begin work. Up to this point the closed metal casing of your analyzer has isolated the components and assemblies inside from any conducted or induced static charges.
4. If you must remove a component from the instrument, do not lay it down on a non-ESD preventative surface where static charges may lie in wait.
5. Only disconnect your wrist strap after you have finished work and closed the case of the analyzer.

12.4.2.2. Working at an Anti-ESD Work Bench.

When working on an instrument or an electronic assembly while it is resting on an anti-ESD work bench

1. Plug your anti-ESD wrist strap into the grounded receptacle of the work station before touching any items on the work station and while standing at least a foot or so away. This will allow any charges you are carrying to bleed away through the ground connection of the work station and prevent discharges due to field effects and induction from occurring.
2. Pause for a second or two to allow any static charges to bleed away.
3. Only open any anti-ESD storage bins or bags containing sensitive devices or assemblies after you have plugged your wrist strap into the work station.
 - Lay the bag or bin on the workbench surface.
 - Before opening the container, wait several seconds for any static charges on the outside surface of the container to be bled away by the work station's grounded protective mat.

4. Do not pick up tools that may be carrying static charges while also touching or holding an ESD Sensitive Device.
 - Only lay tools or ESD-sensitive devices and assemblies on the conductive surface of your workstation. Never lay them down on a non-ESD preventative surfaces.
5. Place any static sensitive devices or assemblies in anti-static storage bags or bins and close the bag or bin before unplugging your wrist strap.
6. Disconnecting your wrist strap is always the last action taken before leaving the work bench.

12.4.2.3. Transferring Components from Rack To Bench and Back

When transferring a sensitive device from an installed Teledyne Instruments analyzer to a Anti-ESD workbench or back:

1. Follow the instructions listed above for working at the instrument rack and work station.
2. Never carry the component or assembly without placing it in a anti-ESD bag or bin.
3. Before using the bag or container allow any surface charges on it to dissipate:
 - If you are at the instrument rack hold the bag in one hand while your wrist strap is connected to a ground point.
 - If you are at a anti-ESD work bench, lay the container down on the conductive work surface.
 - In either case wait several seconds.
4. Place the item in the container.
5. Seal the container. If using a bag, fold the end over and fastening it with anti-ESD tape. Never use standard plastic adhesive tape as a sealer.
 - Folding the open end over isolates the component(s) inside from the effects of static fields.
 - Leaving the bag open or simply stapling it shut without folding it closed prevents the bag from forming a complete protective envelope around the device.
6. Once you have arrived at your destination, allow any surface charges that may have built up on the bag or bin during travel to dissipate:
 - Connect your wrist strap to ground.
 - If you are at the instrument rack hold the bag in one hand while your wrist strap is connected to a ground point.
 - If you are at a anti-ESD work bench, lay the container down on the conductive work surface
 - In either case wait several seconds
7. Open the container.

12.4.2.4. Opening Shipments from and Packing Components for Return to Teledyne Instruments Customer Service.

Packing materials such as bubble pack and Styrofoam pellets are extremely efficient generators of static electric charges. To prevent damage from ESD, Teledyne Instruments ships all electronic components and assemblies in properly sealed ant-ESD containers.

Static charges will build up on the outer surface of the anti-ESD container during shipping as the packing materials vibrate and rub against each other. To prevent these static charges from damaging the components or assemblies being shipped make sure that you:

- Always unpack shipments from Teledyne Instruments Customer Service by:
 - Opening the outer shipping box away from the anti-ESD work area
 - Carry the still sealed ant-ESD bag, tube or bin to the anti-ESD work area
 - Follow steps 6 and 7 of Section 12.4.2.3 above when opening the anti-ESD container at the work station
 - Reserve the anti-ESD container or bag to use when packing electronic components or assemblies to be returned to Teledyne Instruments
- Always pack electronic components and assemblies to be sent to Teledyne Instruments Customer Service in anti-ESD bins, tubes or bags.
 - Do not use pink-poly bags.
 - If you do not already have an adequate supply of anti-ESD bags or containers available, Teledyne Instruments' Customer Service department) will supply them (see Section 11.7 for contact information.
 - Always follow steps 1 through 5 of Section 12.4.1.3

User Notes:

APPENDIX A - Version Specific Software Documentation

APPENDIX A-1: Model 6400E Software Menu Trees

APPENDIX A-2: Model 6400E Setup Variables Available Via Serial I/O

APPENDIX A-3: Model 6400E Warnings and Test Measurements Via Serial I/O

APPENDIX A-4: Model 6400E Signal I/O Definitions

APPENDIX A-5: Model 6400E iDAS Functions

APPENDIX A-6: Model 6400E Terminal Command Designators

APPENDIX A-1: 6400E Software Menu Trees, Revision C.3

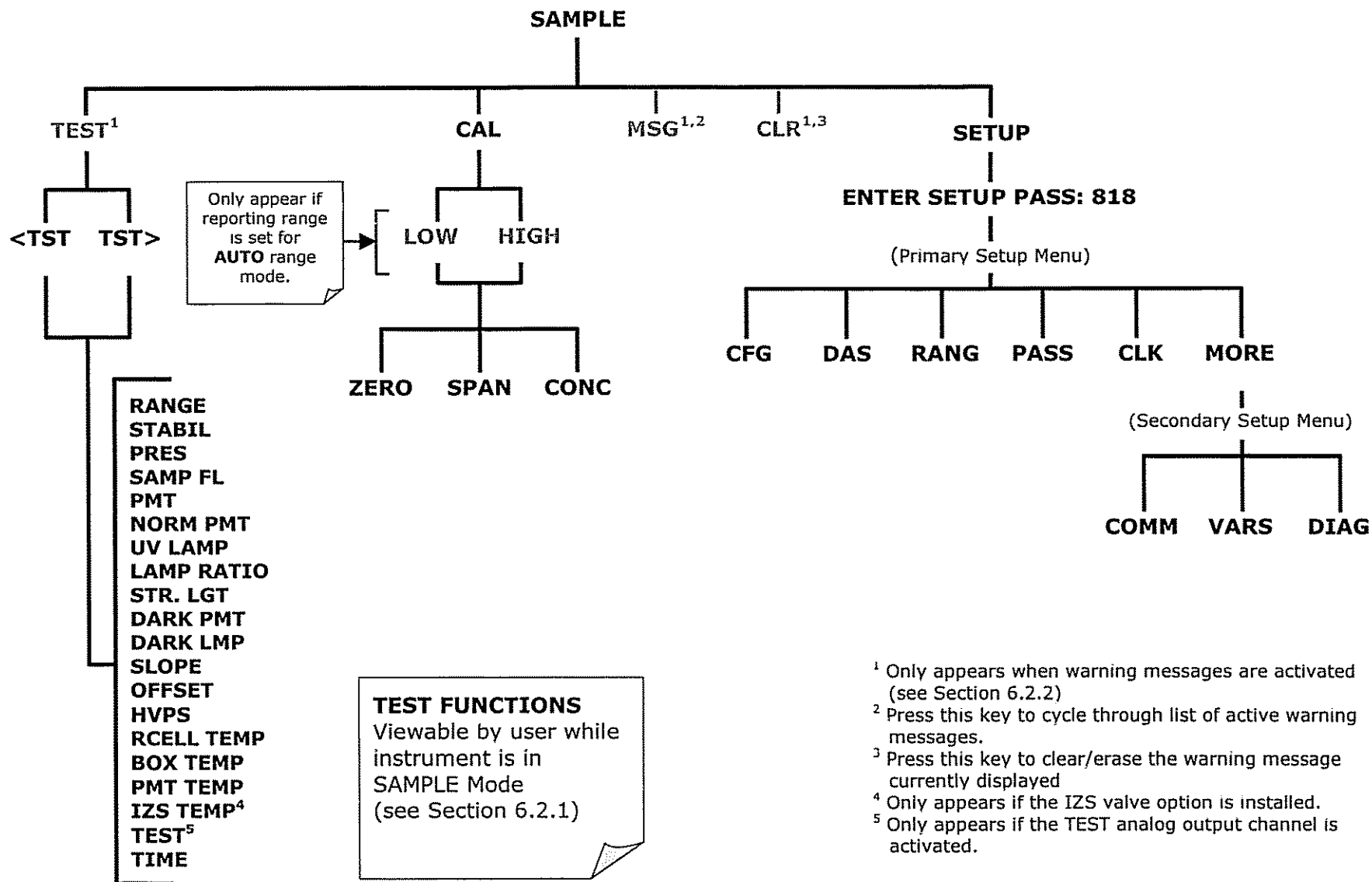

Figure A-1: Basic Sample Display Menu

¹ Only appears when warning messages are activated (see Section 6.2.2)
² Press this key to cycle through list of active warning messages.
³ Press this key to clear/erase the warning message currently displayed
⁴ Only appears if the IZS valve option is installed.
⁵ Only appears if the TEST analog output channel is activated.

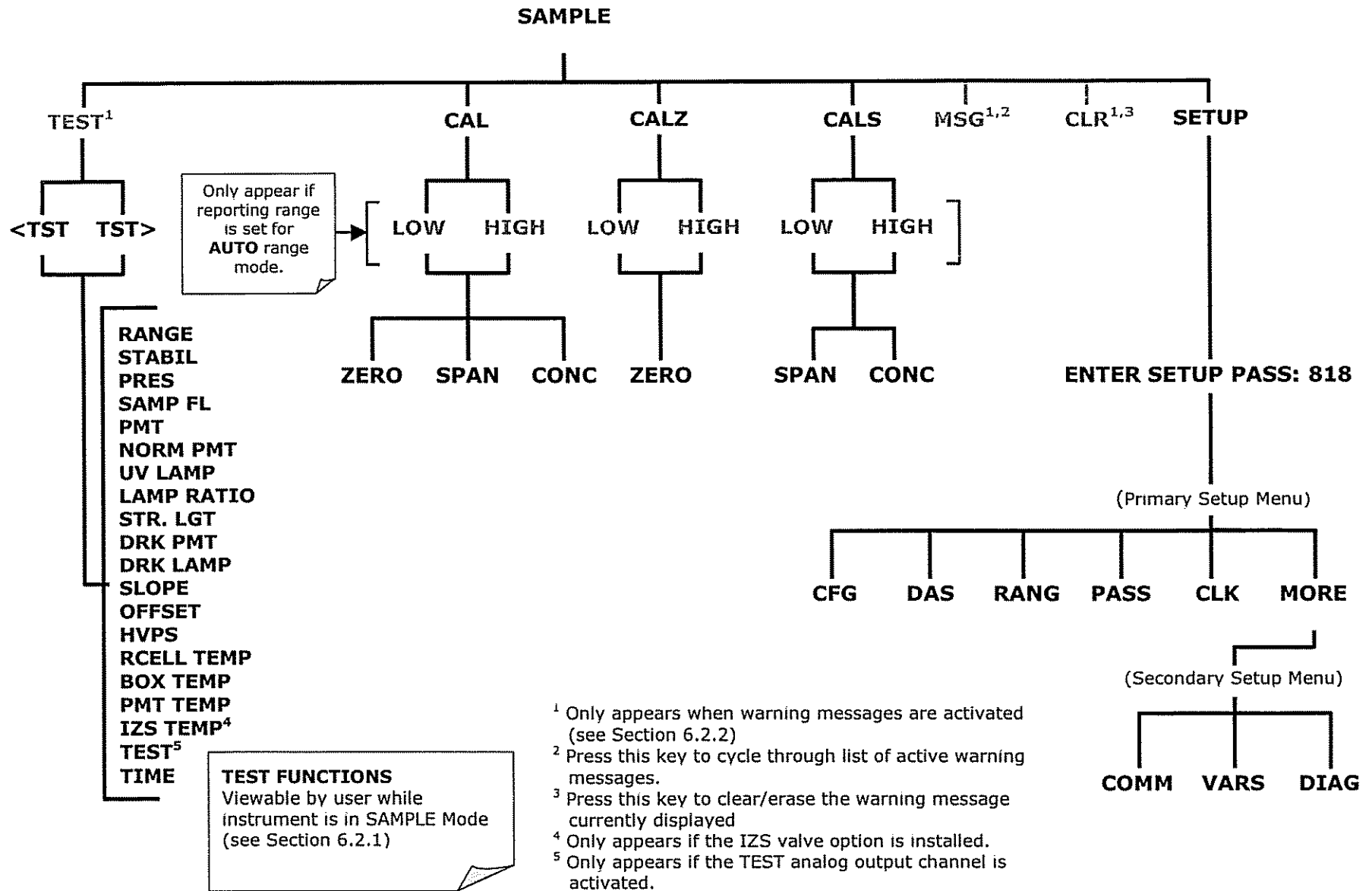

Figure A-2: Sample Display Menu - Units with Z/S Valve or IZS Option installed

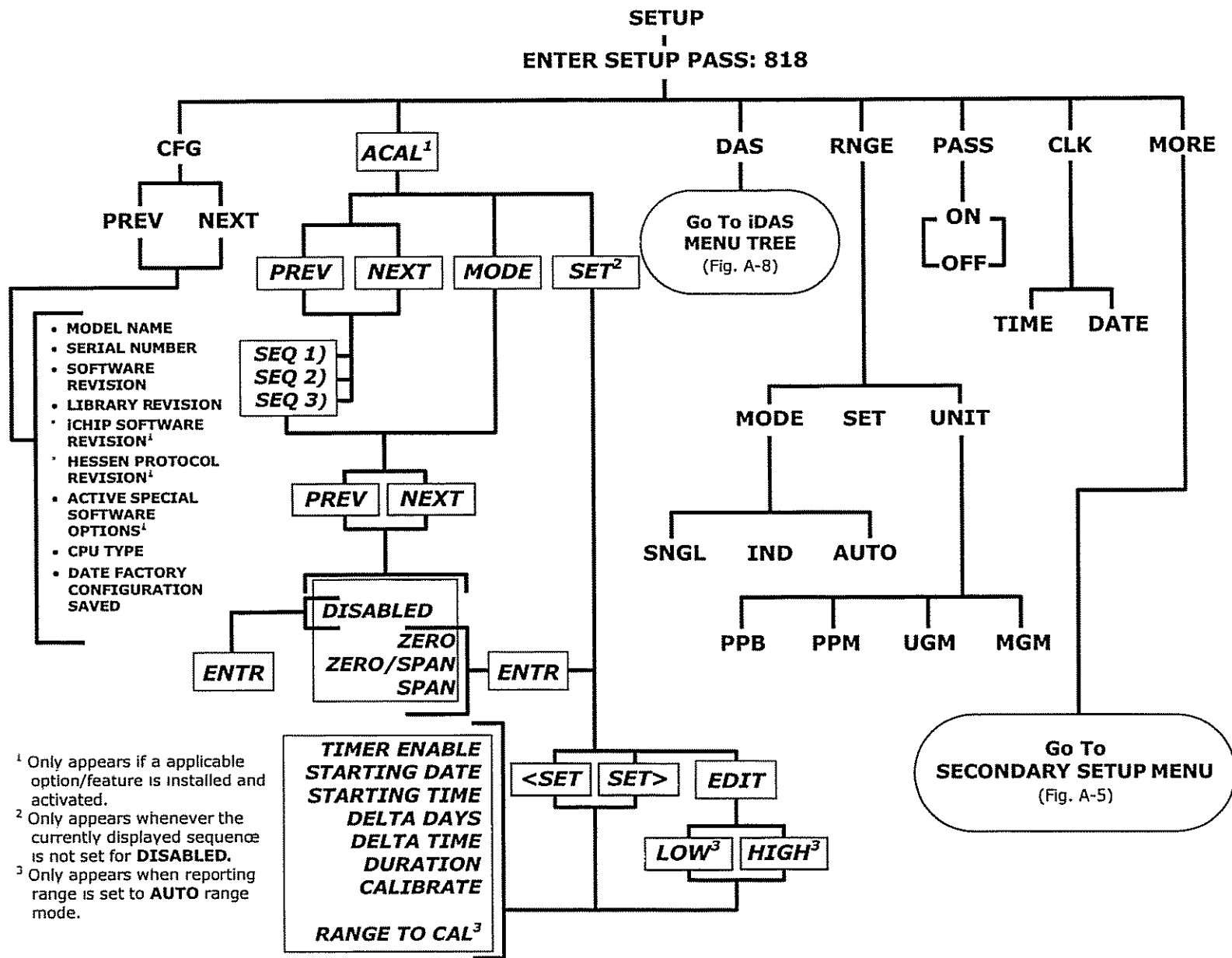

Figure A-3: Primary Setup Menu (Except iDAS)

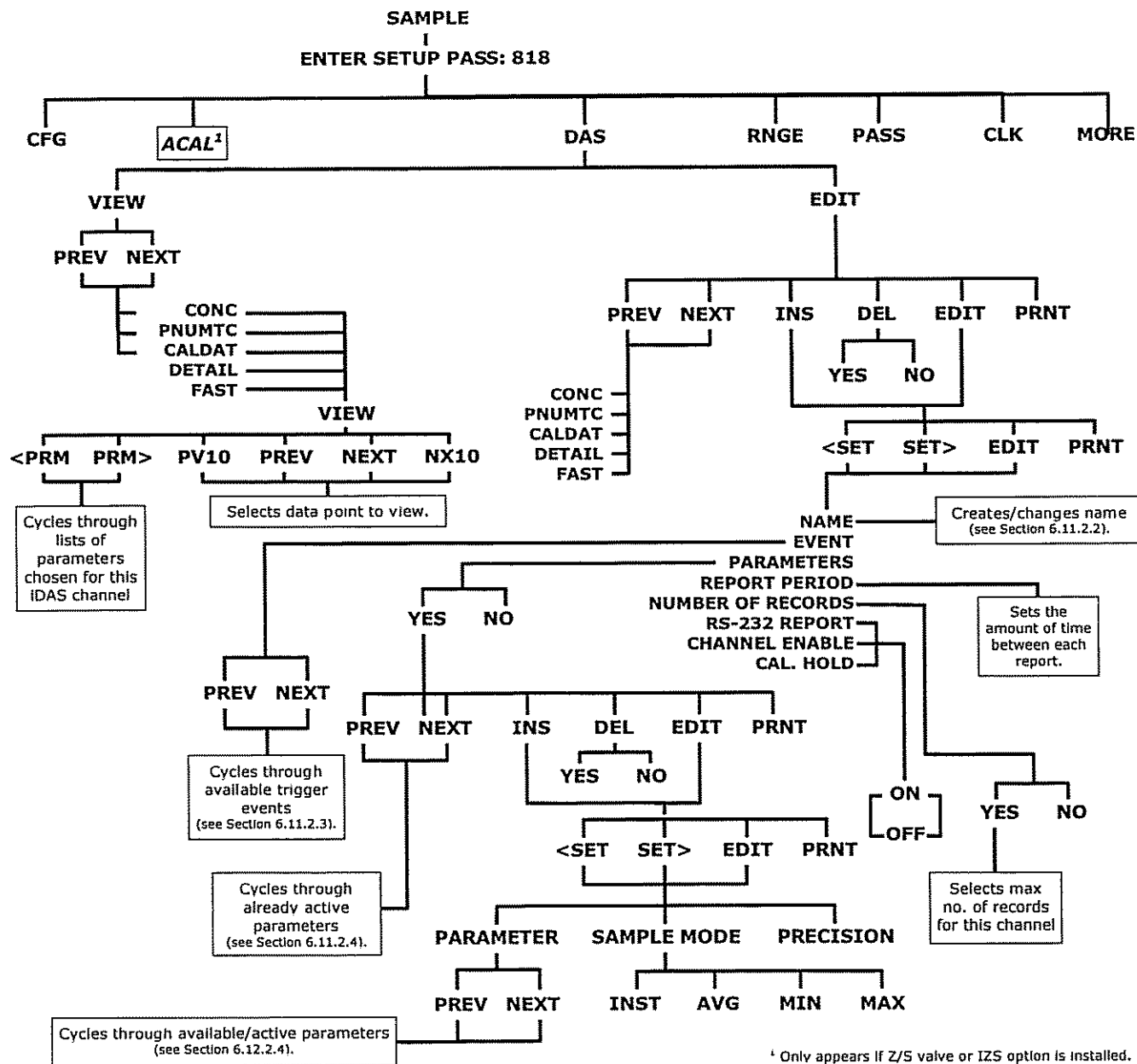
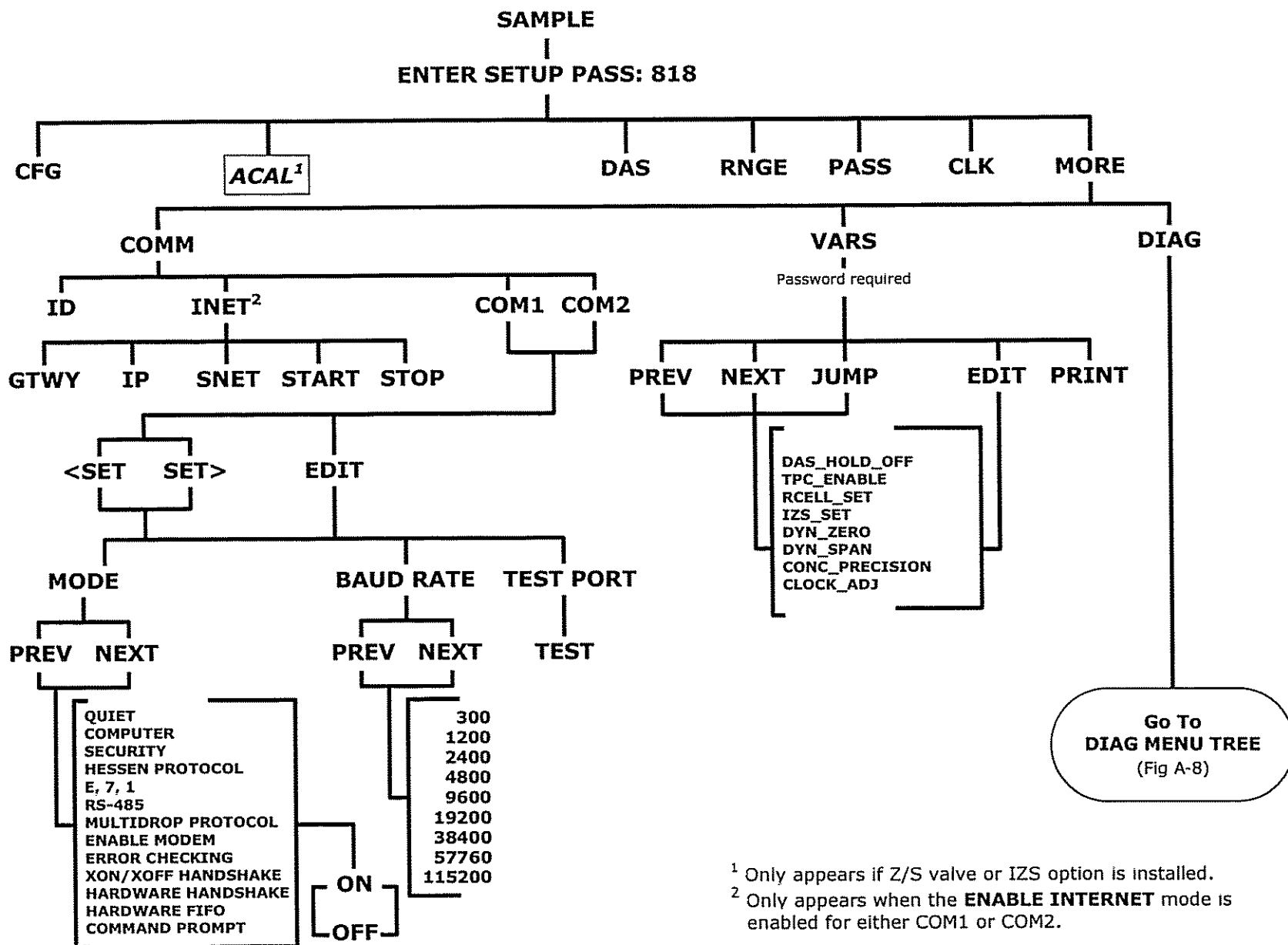

Figure A-4: Primary Setup Menu (iDAS)

¹ Only appears if Z/S valve or IZS option is installed.



¹ Only appears if Z/S valve or IZS option is installed.
² Only appears when the **ENABLE INTERNET** mode is enabled for either COM1 or COM2.

Figure A-5: Secondary Setup Menu (COMM & VARS)

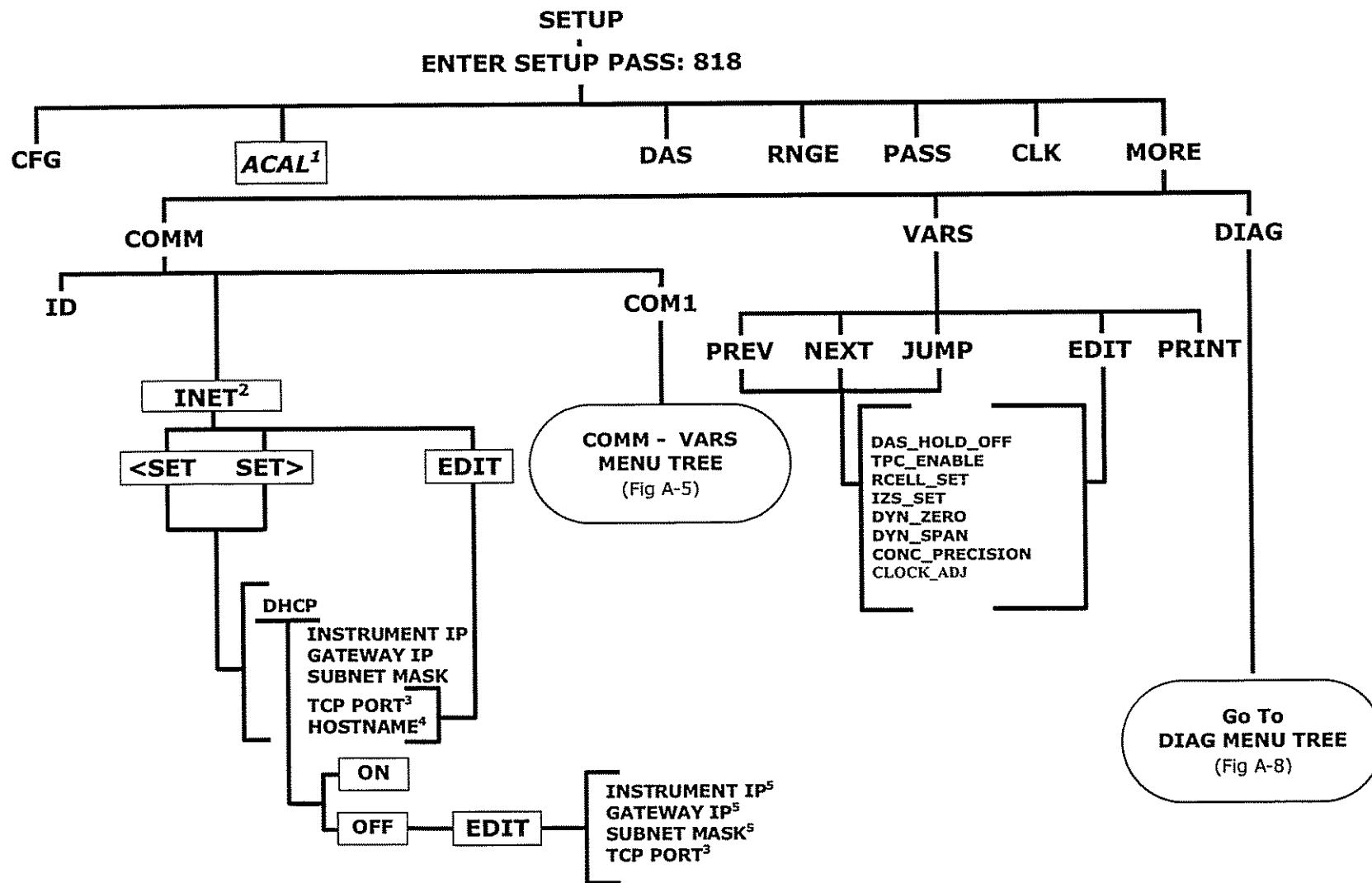

¹ Only appears if a valve option is installed.

² Only appears when the Ethernet card (option 63) is installed.

³ Although **TCP PORT** is editable regardless of the **DHCP** state, do not change the setting for this property unless instructed to by Teledyne Instruments Customer Service personnel.

⁴ **HOST NAME** is only editable when **DHCP** is **ON**.

⁵ **INSTRUMENT IP**, **GATEWAY IP** & **SUBNET MASK** are only editable when **DHCP** is **OFF**.

Figure A-6: Secondary Setup Menu (COMM Menu with Ethernet Card)

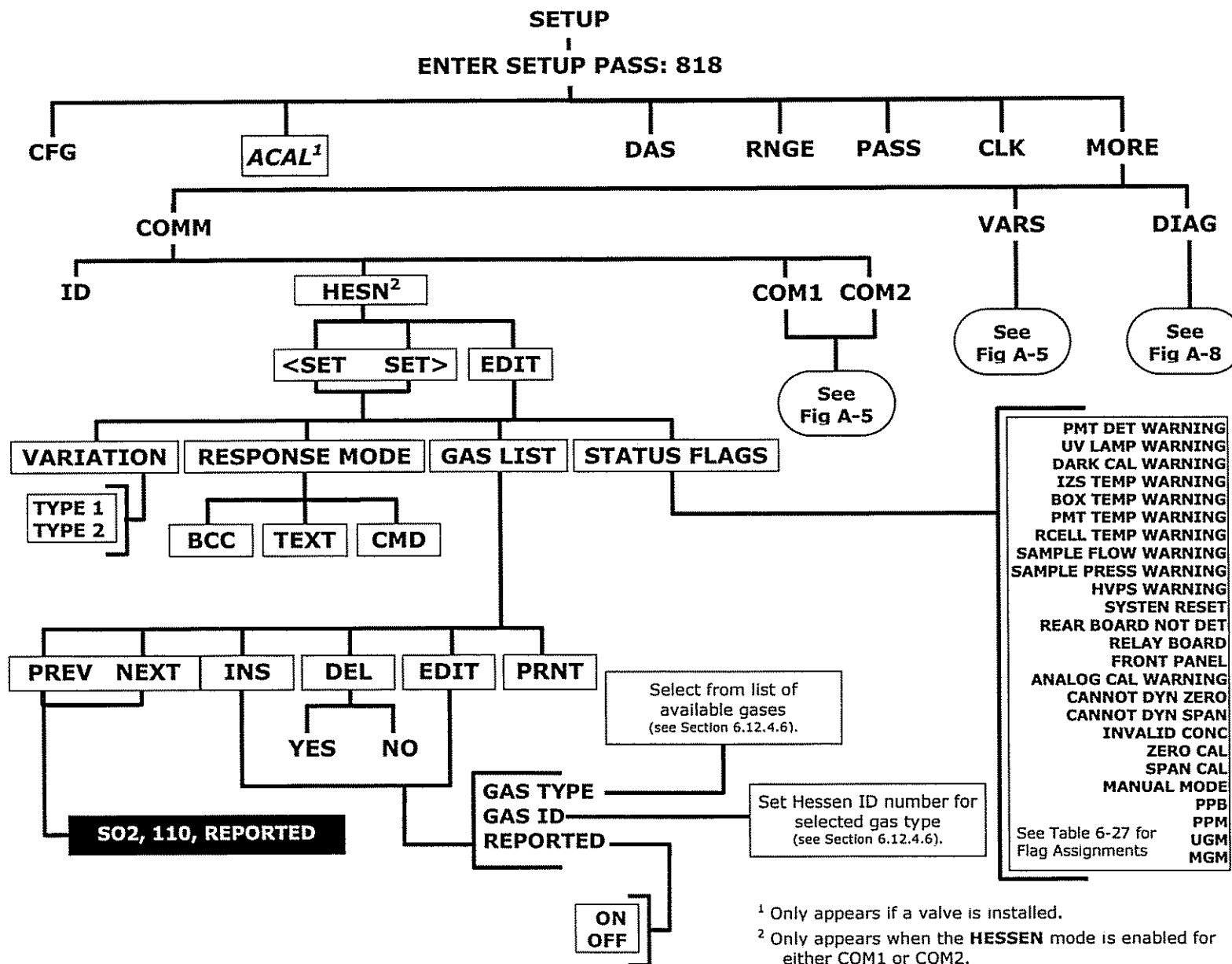

Figure A-7: Secondary Setup Menu - HESSEN Submenu

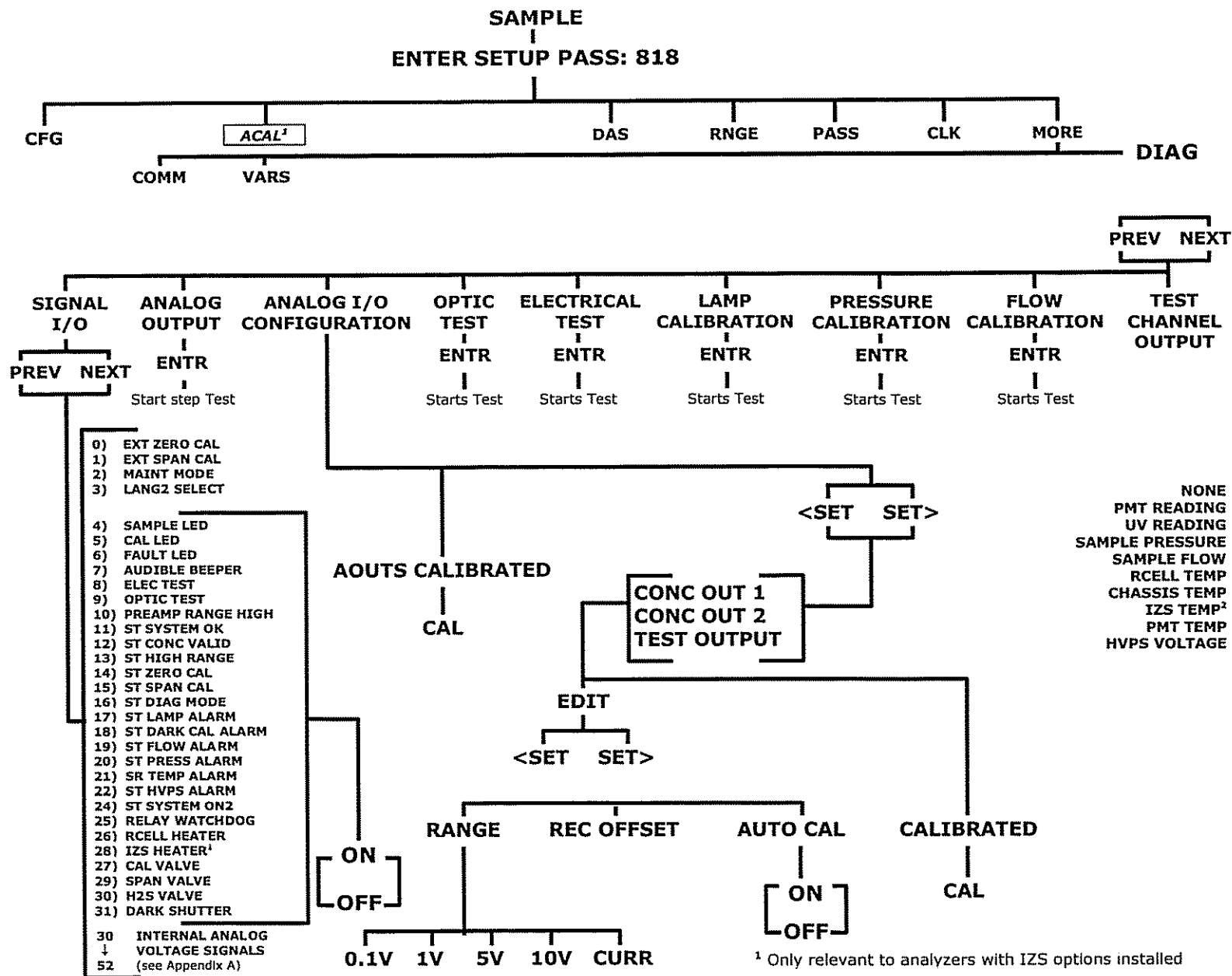

Figure A-8: Secondary Setup Menu (DIAG)

APPENDIX A-2: Setup Variables For Serial I/O, Revision C.3

Table A-1: 6400E Setup Variables, Revision C.3

SETUP VARIABLE	NUMERIC UNITS	DEFAULT VALUE	VALUE RANGE	DESCRIPTION
DAS_HOLD_OFF	Minutes	15	0.5–20	Duration of DAS hold off period.
TPC_ENABLE	—	ON, OFF ⁴	OFF, ON	ON enables temperature and pressure compensation; OFF disables it.
RCELL_SET	°C	50 Warnings: 45–55	30–70	Reaction cell temperature set point and warning limits.
IZS_SET ¹	°C	50 Warnings: 45–55	30–70	IZS temperature set point and warning limits.
DYN_ZERO	—	OFF	OFF, ON	ON enables contact closure dynamic zero; OFF disables it.
DYN_SPAN	—	OFF	OFF, ON	ON enables contact closure dynamic span; OFF disables it.
CONC_PRECISION	—	1	AUTO, 0, 1, 2, 3, 4	Number of digits to display to the right of the decimal point for concentrations on the display. Enclose value in double quotes (") when setting from the RS-232 interface.
CLOCK_ADJ	Sec./Day	0	-60–60	Time-of-day clock speed adjustment.
LANGUAGE_SELECT	—	ENGL	ENGL, SECD, EXTN	Selects the language to use for the user interface. Enclose value in double quotes (") when setting from the RS-232 interface.
MAINT_TIMEOUT	Hours	2	0.1–100	Time until automatically switching out of software-controlled maintenance mode.
CONV_TIME	—	33 MS	33 MS, 66 MS, 133 MS, 266 MS, 533 MS, 1 SEC, 2 SEC	Conversion time for PMT and UV detector channels. Enclose value in double quotes (") when setting from the RS-232 interface.
DWELL_TIME	Seconds	1, 0.2 ⁴	0.1–10	Dwell time before taking each sample.
FILT_SIZE	Samples	240, 30 ³ , 5 ⁴	1–480	Moving average filter size.
FILT_ASIZE	Samples	20, 6 ³	1–100	Moving average filter size in adaptive mode.
FILT_DELTA	PPM	0.02, 10 ³	0.001–0.1, 1–100 ³	Absolute change to trigger adaptive filter.
FILT_PCT	%	5, 10 ¹	1–100	Percent change to trigger adaptive filter.
FILT_DELAY	Seconds	180	0–300	Delay before leaving adaptive filter mode.
FILT_ADAPT	—	ON, OFF ⁴	OFF, ON	ON enables adaptive filter; OFF disables it.
DIL_FACTOR	—	1	0.1–1000	Dilution factor if dilution enabled with <i>FACTORY_OPT</i> variable.
USER_UNITS	—	PPB, PPM ³	PPB, PPM, UGM, MGM	Concentration units for user interface. Enclose value in double quotes (") when setting from the RS-232 interface.
LAMP_CAL	mV	3500	1000–5000	Last calibrated UV lamp reading.

SETUP VARIABLE	NUMERIC UNITS	DEFAULT VALUE	VALUE RANGE	DESCRIPTION
LAMP_GAIN	—	0.9	0.5–1.5	UV lamp compensation attenuation factor.
TEMPCO_GAIN	—	0	0–2	Temperature coefficient attenuation factor for pressure readings.
SLOPE_CONST	—	8, 6.25 ³	0.1–10	Constant to make visible slope close to 1.
DARK_ENABLE ^{1, 3, 4}	—	ON, OFF ⁴	OFF, ON	ON enables PMT/UV dark calibration; OFF disables it.
DARK_FREQ	Minutes	30, 720 ³	0.1–1440	Dark calibration period.
DARK_PRE_DWELL	Seconds	10	1–60	Dwell time after closing dark shutter or turning off lamp or selecting preamp range.
DARK_POST_DWELL	Seconds	10, 30 ³	1–180	Dwell time after opening dark shutter or turning on lamp.
DARK_SAMPLES	Samples	5	1–10	Number of dark samples to average.
DARK_FSIZE	Samples	2	1–100	Dark offset moving average filter size.
DARK_LIMIT	mV	200, 400 ³	0–1000	Maximum dark offset allowed.
SO2_SPAN1	Conc	400, 4000 ³	0.1–50000	Target SO ₂ concentration during span calibration of range 1.
SO2_SLOPE1	PPB/mV, PPM/mV ³	1	0.25–4	SO ₂ slope for range 1.
SO2_OFFSET1	mV	0	-1500–1500	SO ₂ offset for range 1.
SO2_SPAN2	Conc	400, 4000 ³	0.1–50000	Target SO ₂ concentration during span calibration of range 2.
SO2_SLOPE2	PPB/mV, PPM/mV ³	1	0.25–4	SO ₂ slope for range 2.
SO2_OFFSET2	mV	0	-1500–1500	SO ₂ offset for range 2.
RANGE_MODE	—	SNGL	SNGL, DUAL, AUTO, AUTO2	Range control mode. Enclose value in double quotes (") when setting from the RS-232 interface.
PHYS_RANGE1	PPM	2, 500 ³	0.1–2500, 5–10000 ³	Low pre-amp range.
PHYS_RANGE2	PPM	22, 5500 ³	0.1–2500, 5–10000 ³	High pre-amp range.
CONC_RANGE1	Conc	500, 5000 ³	0.1–50000	D/A concentration range 1.
CONC_RANGE2	Conc	500, 5000 ³	0.1–50000	D/A concentration range 2.
ZERO_CONC_THRESH ¹	%	-10	-10.0–10.0	Percentage of CONC_RANGE1 or CONC_RANGE2 to treat as zero concentration. If this is negative, then concentration will peg at threshold when below this threshold.
SAMP_FLOW_SET	cc/m	700, 250 ¹⁺⁶ Warnings: 350–1200, 175–325 ¹⁺⁶	0–1200	Sample flow set point for flow calculation and warning limits.
SAMP_FLOW_SLOPE	—	1	0.5–1.5	Sample flow slope correction factor (adjusted flow = measured flow x slope).
VAC_SAMP_RATIO ³	—	0.53	0.1–2	Maximum vacuum pressure / sample pressure ratio for valid sample flow calculation.

SETUP VARIABLE	NUMERIC UNITS	DEFAULT VALUE	VALUE RANGE	DESCRIPTION
SAMP_PRESS_SET	"Hg	29.92 Warnings: 15-35	0-100	Sample pressure set point for pressure compensation and warning limits.
SAMP_PRESS_SLOPE	—	1	0.5-1.5	Sample pressure slope correction factor (adjusted pressure = measured pressure x slope).
VAC_PRESS_SET ³	"Hg	6 Warnings: 3-10	0-100	Vacuum pressure set point for pressure compensation and warning limits.
BOX_SET	°C	30 Warnings: 8-50	5-60	Box temperature warning limits. Set point is not used.
PMT_SET	°C	7 Warnings: 2-12	0-40	PMT temperature set point and warning limits.
RS232_MODE	BitFlag	0	0-65535	RS-232 COM1 mode flags. Add values to combine flags. 1 = quiet mode 2 = computer mode 4 = enable security 16 = enable Hessen protocol ⁵ 32 = enable multi-drop 64 = enable modem 128 = ignore RS-232 line errors 256 = disable XON / XOFF support 512 = disable hardware FIFOs 1024 = enable RS-485 mode 2048 = even parity, 7 data bits, 1 stop bit 4096 = enable command prompt
BAUD_RATE	—	19200	300, 1200, 2400, 4800, 9600, 19200, 38400, 57600, 115200	RS-232 COM1 baud rate. Enclose value in double quotes (") when setting from the RS-232 interface.
MODEM_INIT	—	"AT YO &D0 &H0 &I0 S0=2 &B0 &N6 &M0 EO Q1 &W0"	Any character in the allowed character set. Up to 100 characters long.	RS-232 COM1 modem initialization string. Sent verbatim plus carriage return to modem on power up or manually. Enclose value in double quotes (") when setting from the RS-232 interface.
RS232_MODE2	BitFlag	0	0-65535	RS-232 COM2 mode flags. (Same settings as RS232_MODE.)
BAUD_RATE2	—	19200	300, 1200, 2400, 4800, 9600, 19200, 38400, 57600, 115200	RS-232 COM2 baud rate. Enclose value in double quotes (") when setting from the RS-232 interface.

SETUP VARIABLE	NUMERIC UNITS	DEFAULT VALUE	VALUE RANGE	DESCRIPTION
MODEM_INIT2	—	"AT Y0 &D0 &H0 &IO S0=2 &B0 &N6 &M0 E0 Q1 &W0"	Any character in the allowed character set. Up to 100 characters long.	RS-232 COM2 modem initialization string. Sent verbatim plus carriage return to modem on power up or manually. Enclose value in double quotes (") when setting from the RS-232 interface.
RS232_PASS	Password	940331	0-999999	RS-232 log on password.
MACHINE_ID	ID	100	0-9999	Unique ID number for instrument.
COMMAND_PROMPT	—	"Cmd> "	Any character in the allowed character set. Up to 100 characters long.	RS-232 interface command prompt. Displayed only if enabled with <i>RS232_MODE</i> variable. Enclose value in double quotes (") when setting from the RS-232 interface.
TEST_CHAN_ID	—	NONE	None, Pmt Reading, UV Reading, Vacuum Pressure3, Sample Pressure, Sample Flow, Rcell Temp, Chassis Temp, IZS Temp 1, Pmt Temp, HVPS Voltage	Diagnostic analog output ID. Enclose value in double quotes (") when setting from the RS-232 interface.
REMOTE_CAL_MODE	—	LOW	LOW, HIGH	Range to calibrate during contact-closure and Hessen calibration. Enclose value in double quotes (") when setting from the RS-232 interface.
PASS_ENABLE	—	OFF	OFF, ON	ON enables passwords; OFF disables them.
STABIL_FREQ	Seconds	10	1-300	Stability measurement sampling period.
STABIL_SAMPLES	Samples	25	2-40	Number of samples in concentration stability reading.
RCELL_CYCLE	Seconds	2	0.5-30	Reaction cell temperature control cycle period.
RCELL_PROP	1/°C	0.3	0-10	Reaction cell temperature PID proportional coefficient.
RCELL_INTEG	—	0.005	0-10	Reaction cell temperature PID integral coefficient.
RCELL_DERIV	—	0.5	0-10	Reaction cell temperature PID derivative coefficient.
IZS_CYCLE ¹	Seconds	2	0.5-30	IZS temperature control cycle period.
IZS_PROP ¹	1/°C	1	0-10	IZS temperature PID proportional coefficient.
IZS_INTEG ¹	—	0.03	0-10	IZS temperature PID integral coefficient.
IZS_DERIV ¹	—	0	0-10	IZS temperature PID derivative coefficient.

SETUP VARIABLE	NUMERIC UNITS	DEFAULT VALUE	VALUE RANGE	DESCRIPTION
HVPS_SET	Volts	650, 550 ³ Warnings: 400-900, 400-700 ³	0-2000	High voltage power supply warning limits. Set point is not used.
DETECTOR_LIMIT	mV	1000 Warnings: 600-4995	0-5000	UV lamp and PMT detector warning limits. Set point is not used.
CONC_LIN_ENABLE ³	—	ON	OFF, ON	ON enables concentration linearization; OFF disables it.
SERIAL_NUMBER	—	"00000000"	Any character in the allowed character set. Up to 100 characters long.	Unique serial number for instrument. Enclose value in double quotes (") when setting from the RS-232 interface.
DISP_INTENSITY	—	HIGH	HIGH, MED, LOW, DIM	Front panel display intensity. Enclose value in double quotes (") when setting from the RS-232 interface.
I2C_RESET_ENABLE	—	ON	OFF, ON	I ² C bus automatic reset enable.
CLOCK_FORMAT	—	"TIME= %H:%M:%S"	Any character in the allowed character set. Up to 100 characters long.	Time-of-day clock format flags. Enclose value in double quotes (") when setting from the RS-232 interface. "%a" = Abbreviated weekday name. "%b" = Abbreviated month name. "%d" = Day of month as decimal number (01 - 31). "%H" = Hour in 24-hour format (00 - 23). "%I" = Hour in 12-hour format (01 - 12). "%j" = Day of year as decimal number (001 - 366). "%m" = Month as decimal number (01 - 12). "%M" = Minute as decimal number (00 - 59). "%p" = A.M./P.M. indicator for 12-hour clock. "%S" = Second as decimal number (00 - 59). "%w" = Weekday as decimal number (0 - 6; Sunday is 0). "%y" = Year without century, as decimal number (00 - 99). "%Y" = Year with century, as decimal number. "%%" = Percent sign.

SETUP VARIABLE	NUMERIC UNITS	DEFAULT VALUE	VALUE RANGE	DESCRIPTION
FACTORY_OPT	BitFlag	0	0-65535	Factory option flags. Add values to combine flags. 1 = enable dilution factor 2 = zero/span valves installed 4 = IZS installed (implies zero/span valves installed) 8 = low span valve installed 16 = display units in concentration field 32 = enable software-controlled maintenance mode 64 = enable lamp power analog output 128 = enable switch-controlled maintenance mode 2048 = enable Internet option
¹ 6400E. ¹ 6400ES. ³ 6400EH. ⁴ 6400EF. ⁵ Must power-cycle instrument for these options to fully take effect. ⁶ Low span option.				

APPENDIX A-3: Warnings and Test Functions, Revision C.3

Table A-2: 6400E Warning Messages, Revision C.3

NAME	MESSAGE TEXT	DESCRIPTION
WSYSRES	SYSTEM RESET	Instrument was power-cycled or the CPU was reset.
WDATAINIT	DATA INITIALIZED	Data storage was erased.
WCONFIGINIT	CONFIG INITIALIZED	Configuration storage was reset to factory configuration or erased.
WPMT	PMT DET WARNING	PMT detector outside of warning limits specified by DETECTOR_LIMIT variable.
WUVLAMP	UV LAMP WARNING	UV lamp reading outside of warning limits specified by DETECTOR_LIMIT variable.
WSAMPFLOW	SAMPLE FLOW WARN	Sample flow outside of warning limits specified by SAMP_FLOW_SET variable.
WSAMPPRESS	SAMPLE PRESS WARN	Sample pressure outside of warning limits specified by SAMP_PRESS_SET variable.
WVACPRESS ¹	VACUUM PRESS WARN	Vacuum pressure outside of warning limits specified by VAC_PRESS_SET variable.
WBOXTEMP	BOX TEMP WARNING	Chassis temperature outside of warning limits specified by BOX_SET variable.
WRCELLTEMP	RCELL TEMP WARNING	Reaction cell temperature outside of warning limits specified by RCELL_SET variable.
WIZSTEMP	IZS TEMP WARNING	IZS temperature outside of warning limits specified by IZS_SET variable.
WPMTEMP	PMT TEMP WARNING	PMT temperature outside of warning limits specified by PMT_SET variable.
WDARKCAL ¹	DARK CAL WARNING	Dark offset above limit specified by DARK_LIMIT variable.
WHVPS	HVPS WARNING	High voltage power supply output outside of warning limits specified by HVPS_SET variable.
WDYNZERO	CANNOT DYN ZERO	Contact closure zero calibration failed while DYN_ZERO was set to ON.
WDYNSPAN	CANNOT DYN SPAN	Contact closure span calibration failed while DYN_SPAN was set to ON.
WREARBOARD	REAR BOARD NOT DET	Rear board was not detected during power up.
WRELAYBOARD	RELAY BOARD WARN	Firmware is unable to communicate with the relay board.
WFRONTPANEL	FRONT PANEL WARN	Firmware is unable to communicate with the front panel.
WANALOGCAL	ANALOG CAL WARNING	The A/D or at least one D/A channel has not been calibrated.
¹ 6400EH		

Table A-3: 6400E Test Functions, Revision C.3

TEST FUNCTION	MESSAGE TEXT	DESCRIPTION
RANGE	RANGE=500.0 PPB 3	D/A range in single or auto-range modes.
RANGE1	RANGE1=500.0 PPB 3	D/A #1 range in independent range mode.
RANGE2	RANGE2=500.0 PPB 3	D/A #2 range in independent range mode.
STABILITY	STABIL=0.0 PPB 3	Concentration stability (standard deviation based on setting of STABIL_FREQ and STABIL_SAMPLES).
VACUUM ¹	VAC=9.1 IN-HG-A	Vacuum pressure.
SAMPPRESS	PRES=29.9 IN-HG-A	Sample pressure.
SAMPFLOW	SAMP FL=700 CC/M	Sample flow rate.
PMTDET	PMT=762.5 MV	Raw PMT reading.
NORMPMTDET	NORM PMT=742.9 MV	PMT reading normalized for temperature, pressure, auto-zero offset, but not range.
UVDET	UV LAMP=3457.6 MV	UV lamp reading.
LAMP RATIO	LAMP RATIO=100.0 %	UV lamp ratio of current reading divided by calibrated reading.
STRAYLIGHT	STR. LGT=0.1 PPB	Stray light offset.
DARKPMT	DRK PMT=19.6 MV	PMT dark offset.
DARKLAMP	DRK LMP=42.4 MV	UV lamp dark offset.
SLOPE	SLOPE=1.061	Slope for current range, computed during zero/span calibration.
OFFSET	OFFSET=250.0 MV	Offset for current range, computed during zero/span calibration.
HVPS	HVPS=650 VOLTS	High voltage power supply output.
RCELLDUTY	RCELL ON=0.00 SEC	Reaction cell temperature control duty cycle.
RCELLTEMP	RCELL TEMP=52.1 C	Reaction cell temperature.
BOXTEMP	BOX TEMP=35.5 C	Internal chassis temperature.
PMTTEMP	PMT TEMP=7.0 C	PMT temperature.
IZSDUTY	IZS ON=0.00 SEC	IZS temperature control duty cycle.
IZSTEMP	IZS TEMP=52.2 C	IZS temperature.
SO2	SO2=261.4 PPB	SO2 concentration for current range.
TESTCHAN	TEST=3721.1 MV	Value output to TEST_OUTPUT analog output, selected with TEST_CHAN_ID variable.
CLOCKTIME	TIME=10:38:27	Current instrument time of day clock.
¹ 6400EH		

APPENDIX A-4: 6400E Signal I/O Definitions, Revision C.3

Table A-4: 6400E Signal I/O Definitions, Revision C.3

SIGNAL NAME	BIT OR CHANNEL NUMBER	DESCRIPTION
Internal inputs, U7, J108, pins 9-16 = bits 0-7, default I/O address 322 hex		
	0-7	Spare
Internal outputs, U8, J108, pins 1-8 = bits 0-7, default I/O address 322 hex		
ELEC_TEST	0	1 = electrical test on 0 = off
OPTIC_TEST	1	1 = optic test on 0 = off
PREAMP_RANGE_HI	2	1 = select high preamp range 0 = select low range
	3-5	Spare
I2C_RESET	6	1 = reset I ² C peripherals 0 = normal
I2C_DRV_RST	7	0 = hardware reset 8584 chip 1 = normal
Control inputs, U11, J1004, pins 1-6 = bits 0-5, default I/O address 321 hex		
EXT_ZERO_CAL	0	0 = go into zero calibration 1 = exit zero calibration
EXT_SPAN_CAL	1	0 = go into span calibration 1 = exit span calibration
EXT_LOW_SPAN ^{1, 6}	2	0 = go into low span calibration 1 = exit low span calibration
	3-5	Spare
	6-7	Always 1
Control inputs, U14, J1006, pins 1-6 = bits 0-5, default I/O address 325 hex		
	0-5	Spare
	6-7	Always 1
Control outputs, U17, J1008, pins 1-8 = bits 0-7, default I/O address 321 hex		
	0-7	Spare
Control outputs, U21, J1008, pins 9-12 = bits 0-3, default I/O address 325 hex		
	0-3	Spare
Alarm outputs, U21, J1009, pins 1-12 = bits 4-7, default I/O address 325 hex		
ST_SYSTEM_OK2	4	1 = system OK 0 = any alarm condition or in diagnostics mode
	5-7	Spare
A status outputs, U24, J1017, pins 1-8 = bits 0-7, default I/O address 323 hex		
ST_SYSTEM_OK	0	0 = system OK 1 = any alarm condition
ST_CONC_VALID	1	0 = conc. valid

SIGNAL NAME	BIT OR CHANNEL NUMBER	DESCRIPTION
		1 = warnings or other conditions that affect validity of concentration
ST_HIGH_RANGE	2	0 = high auto-range in use 1 = low auto-range
ST_ZERO_CAL	3	0 = in zero calibration 1 = not in zero
ST_SPAN_CAL	4	0 = in span calibration 1 = not in span
ST_DIAG_MODE	5	0 = in diagnostic mode 1 = not in diagnostic mode
ST_LOW_SPAN_CAL ^{1,6}	6	0 = in low span calibration 1 = not in low span
	7	Spare
B status outputs, U27, J1018, pins 1-8 = bits 0-7, default I/O address 324 hex		
ST_LAMP_ALARM	0	0 = lamp intensity low 1 = lamp intensity OK
ST_DARK_CAL_ALARM	1	0 = dark cal. warning 1 = dark cal. OK
ST_FLOW_ALARM	2	0 = any flow alarm 1 = all flows OK
ST_PRESS_ALARM	3	0 = any pressure alarm 1 = all pressures OK
ST_TEMP_ALARM	4	0 = any temperature alarm 1 = all temperatures OK
ST_HVPS_ALARM	5	0 = HVPS alarm 1 = HVPS OK
	6-7	Spare
Front panel I¹C keyboard, default I¹C address 4E hex		
MAINT_MODE	5 (input)	0 = maintenance mode 1 = normal mode
LANG2_SELECT	6 (input)	0 = select second language 1 = select first language (English)
SAMPLE_LED	8 (output)	0 = sample LED on 1 = off
CAL_LED	9 (output)	0 = cal. LED on 1 = off
FAULT_LED	10 (output)	0 = fault LED on 1 = off
AUDIBLE_BEEPER	14 (output)	0 = beeper on (for diagnostic testing only) 1 = off
Relay board digital output (PCF8575), default I¹C address 44 hex		
RELAY_WATCHDOG	0	Alternate between 0 and 1 at least every 5 seconds

SIGNAL NAME	BIT OR CHANNEL NUMBER	DESCRIPTION
		to keep relay board active
RCELL_HEATER	1	0 = reaction cell heater on 1 = off
	2-3	Spare
IZS_HEATER	4	0 = IZS heater on 1 = off
	5	Spare
CAL_VALVE	6	0 = let cal. gas in 1 = let sample gas in
SPAN_VALVE	7	0 = let span gas in 1 = let zero gas in
LOW_SPAN_VALVE ^{1,6}	8	0 = let low span gas in 1 = let sample gas in
ZERO_VALVE ¹	9	0 = let zero gas in 1 = let sample gas in
DARK_SHUTTER	10	0 = close dark shutter 1 = open
	11-15	Spare
Rear board primary MUX analog inputs		
PMT_SIGNAL	0	PMT detector
HVPS_VOLTAGE	1	HV power supply output
PMT_TEMP	2	PMT temperature
UVLAMP_SIGNAL	3	UV lamp intensity
	4	Temperature MUX
	5-6	Spare
SAMPLE_PRESSURE	7	Sample pressure
TEST_INPUT_8	8	Diagnostic test input
REF_4096_MV	9	4.096V reference from MAX6241
SAMPLE_FLOW	10	Sample flow rate
VACUUM_PRESSURE ¹	10	Vacuum pressure
TEST_INPUT_11	11	Diagnostic test input
	12-13	Spare (thermocouple input?)
	14	DAC MUX
REF_GND	15	Ground reference
Rear board temperature MUX analog inputs		
BOX_TEMP	0	Internal box temperature
RCELL_TEMP	1	Reaction cell temperature
IZS_TEMP	2	IZS temperature
	3	Spare
TEMP_INPUT_4	4	Diagnostic temperature input
TEMP_INPUT_5	5	Diagnostic temperature input

SIGNAL NAME	BIT OR CHANNEL NUMBER	DESCRIPTION
TEMP_INPUT_6	6	Diagnostic temperature input
	7	Spare
Rear board DAC MUX analog inputs		
DAC_CHAN_0	0	DAC channel 0 loopback
DAC_CHAN_1	1	DAC channel 1 loopback
DAC_CHAN_2	2	DAC channel 2 loopback
DAC_CHAN_3	3	DAC channel 3 loopback
Rear board analog outputs		
CONC_OUT_1	0	Concentration output #1
CONC_OUT_2	1	Concentration output #2
TEST_OUTPUT	2	Test measurement output
	3	Spare
I²C analog output (AD5321), default I²C address 18 hex		
LAMP_POWER ²	0	Lamp power (0-5V)
¹ 6400EH. ² Low span option.		

APPENDIX A-5: 6400E iDAS Functions, Revision C.3

Table A-5: 6400E DAS Trigger Events, Revision C.3

NAME	DESCRIPTION
ATIMER	Automatic timer expired
EXITZR	Exit zero calibration mode
EXITLS ^{2,3}	Exit low span calibration mode
EXITHS	Exit high span calibration mode
EXITMP	Exit multi-point calibration mode
SLPCHG	Slope and offset recalculated
EXITDG	Exit diagnostic mode
PMTDTW	PMT detector warning
UVLMPW	UV lamp warning
DRKCLW ¹	Dark calibration warning
RCTMPW	Reaction cell temperature warning
IZTMPW ¹	IZS temperature warning
PTEMPW	PMT temperature warning
SFLOWW	Sample flow warning
SPRESW	Sample pressure warning
VPRESW ²	Vacuum pressure warning
BTEMPW	Box temperature warning
HVPSW	High voltage power supply warning
¹	6400E only.
²	6400EH.
³	Low span option.

Table A-6: 6400E iDAS Functions, Revision C.3

NAME	DESCRIPTION	UNITS
PMTDET	PMT detector reading	mV
UVDET	UV lamp intensity reading	mV
LAMPR	UV lamp ratio of calibrated intensity	%
DRKPMT	PMT electrical offset	mV
DARKUV	UV lamp electrical offset	mV
SLOPE1	SO ₂ slope for range #1	—
SLOPE2	SO ₂ slope for range #2	—
OFFSET1	SO ₂ offset for range #1	mV
OFFSET2	SO ₂ offset for range #2	mV
ZSCNC1	SO ₂ concentration for range #1 during zero/span calibration, just before computing new slope and offset	PPB
ZSCNC2	SO ₂ concentration for range #2 during zero/span calibration, just before computing new slope and offset	PPB
CONC1	SO ₂ concentration for range #1	PPB
CONC2	SO ₂ concentration for range #2	PPB
STABIL	SO ₂ concentration stability	PPB
STRLGT	Stray light reading	PPB
RCTEMP	Reaction cell temperature	°C
IZSTMP ¹	IZS temperature	°C
PMTTMP	PMT temperature	°C
SMPFLW ^{1, 2}	Sample flow	cc/m
SMPPRS	Sample pressure	"Hg
VACUUM ²	Vacuum pressure	"Hg
BOXTMP	Internal box temperature	°C
HVPS	High voltage power supply output	Volts
TEST8	Diagnostic test input (TEST_INPUT_8)	mV
TEST11	Diagnostic test input (TEST_INPUT_11)	mV
TEMP4	Diagnostic temperature input (TEMP_INPUT_4)	°C
TEMP5	Diagnostic temperature input (TEMP_INPUT_5)	°C
TEMP6	Diagnostic temperature input (TEMP_INPUT_6)	°C
REFGND	Ground reference (REF_GND)	mV
RF4096	4096 mV reference (REF_4096_MV)	mV
¹ 6400E only.		
² 6400EH.		

APPENDIX A-6: Terminal Command Designators, Revision C.3

Table A-7: Terminal Command Designators, Revision C.3

COMMAND	ADDITIONAL COMMAND SYNTAX	DESCRIPTION
? [ID]		Display help screen and this list of commands
LOGON [ID]	password	Establish connection to instrument
LOGOFF [ID]		Terminate connection to instrument
T [ID]	SET ALL name hexmask	Display test(s)
	LIST [ALL name hexmask] [NAMES HEX]	Print test(s) to screen
	name	Print single test
	CLEAR ALL name hexmask	Disable test(s)
W [ID]	SET ALL name hexmask	Display warning(s)
	LIST [ALL name hexmask] [NAMES HEX]	Print warning(s)
	name	Clear single warning
	CLEAR ALL name hexmask	Clear warning(s)
C [ID]	ZERO LOWSPAN SPAN [1 2]	Enter calibration mode
	ASEQ number	Execute automatic sequence
	COMPUTE ZERO SPAN	Compute new slope/offset
	EXIT	Exit calibration mode
	ABORT	Abort calibration sequence
D [ID]	LIST	Print all I/O signals
	name[=value]	Examine or set I/O signal
	LIST NAMES	Print names of all diagnostic tests
	ENTER name	Execute diagnostic test
	EXIT	Exit diagnostic test
	RESET [DATA] [CONFIG] [exitcode]	Reset instrument
	PRINT ["name"] [SCRIPT]	Print iDAS configuration
	RECORDS ["name"]	Print number of iDAS records
	REPORT ["name"] [RECORDS=number] [FROM=<start date>][TO=<end date>][VERBOSE COMPACT HEX] (Print DAS records)(date format: MM/DD/YYYY(or YY) [HH:MM:SS])	Print iDAS records
CANCEL	Halt printing iDAS records	
V [ID]	LIST	Print setup variables
	name[=value [warn_low [warn_high]]]	Modify variable
	name="value"	Modify enumerated variable
	CONFIG	Print instrument configuration
	MAINT ON OFF	Enter/exit maintenance mode
	MODE	Print current instrument mode
	DASBEGIN [<data channel definitions>] DASEND	Upload iDAS configuration
	CHANNELBEGIN propertylist CHANNELEND	Upload single iDAS channel
	CHANNELDELETE ["name"]	Delete iDAS channels

The command syntax follows the command type, separated by a space character. Strings in [brackets] are optional designators. The following key assignments also apply.

TERMINAL KEY ASSIGNMENTS	
ESC	Abort line
CR (ENTER)	Execute command
Ctrl-C	Switch to computer mode
COMPUTER MODE KEY ASSIGNMENTS	
LF (line feed)	Execute command
Ctrl-T	Switch to terminal mode

APPENDIX B - 6400E Spare Parts List

NOTE

Use of replacement parts other than those supplied by API may result in non-compliance with European standard EN 61010-1.

Table B-1: 6400E Spare Parts List

PART NUMBER	DESCRIPTION	NOTES
000940100	Orifice, 3 mil, 60 cc (IZS)	
000940800	Orifice, 12 mil, 650 cc, Rx Cell	
002690000	Lens, UV (002-039700)	
002700000	Lens, PMT (002-039800)	
002720000	PMT Optical Filter (002-035300)	
003290000	Thermistor Assembly (885-071600)	
003690000	Filter, TFE, 37 mm, Qty. 100 (872-006400)	
00596000E0	Activated Charcoal, 6 lbs	
00816000E0	M100 47 mm Filter Holder	
009690000	Filter, TFE, 47 mm, Qty. 100	
009690100	Filter, TFE, 47 mm, Qty. 25	
013390000	Hydrocarbon scrubber Assembly, M100A	
013400000	PMT, SO ₂	
013420000	Rotary Solenoid Assembly (Shutter Solenoid)	
013570000	Thermistor Assembly (Cooler)	
014080100	Assembly, High Voltage Power Supply	
014400000	Zero Air Scrubber for IZS	
014610000	Cooler Assembly	
024180000	CD, UV Filter 214 NM	
024710000	Tubing: 6', 1/8" CLR	
024720000	Tubing: 6', 1/8" BLK	
024750000	Tubing: 6', 1/4" TYGON	
040300100	115V Configuration Plug	
041510100	PRESS/FLOW SEN	
041520200	Module, Relay PCA & Power Supply	
04166000E0	PCA, UV Lamp Power Supply	
041800100	PCA, PMT Preamp, 6400E	
042410200	Internal Pump Assy	
045570000	UV Lamp Assy, 6400E	
FL0000001	Sintered Filter (002-024900)	
FL0000003	Filter, DFU (036-040180)	

PART NUMBER	DESCRIPTION	NOTES
FM0000004	Flow Meter, 0-1000 cc	
HE0000018	Heater, 50W (IZS)	
HW0000020	Spring, Flow Control	
HW0000036	TFE Thread Tape (48 FT)	
KIT000019	Replacement Cooler Assembly, M100A/M200A	
KIT000028	Retrofit , 37mm Retaining Ring, Sample Filter	
KIT000029	Retrofit , 47mm Retaining Ring, Sample Filter	
OP0000012	UV Detector	
OR0000001	O-Ring, Flow Control	
OR0000004	O-Ring, Optic/Cell, Cell/Trap	
OR0000006	O-Ring, Cell/PMT	
OR0000007	O-Ring, PMT, Barrel, Cell	
OR0000015	O-Ring, PMT Filter	
OR0000016	O-Ring, UV Lens	
OR0000025	O-Ring, Zero Air Scrubber	
OR0000042	O-Ring, Sensor Assembly	
OR0000046	O-Ring, Permeation Oven	
SW0000006	Overheat SW, Cell/Oven	
VA0000033	3-Way Solenoid Valve, Teflon, 12V (IZS)	

05038 Rev A

Appendix C - Repair Questionnaire - 6400E

Customer: _____ Phone: _____

Contact Name: _____ Fax No.: _____

Site Address: _____

Model 6400E Serial No.: _____ Firmware Revision: _____

1. Are there any failure messages? _____

2. Please complete the following table: (note: depending on options installed, not all test parameters below will be available in your instrument)

PARAMETER	RECORDED VALUE	ACCEPTABLE VALUE
RANGE	PPB/PPM	N/A
STABIL	PPB	≤1 PPB WITH ZERO AIR
SAMP PRESS	IN-HG-A	AMBIENT ± 2 IN-HG-A
SAMPLE FLOW	CM ³ /MIN	650 ± 10%
PMT SIGNAL WITH ZERO AIR	mV	-20 TO 150 mV
PMT SIGNAL AT SPAN GAS CONC	mV PPB/PPM	0-5000 mV 0-20000 PPB
NORM PMT AT SPAN GAS CONC	mV PPB/PPM	0-5000 mV 0-20000 PPB
UV LAMP	mV	2000 TO 4000 mV
LAMP RATIO	mV	30 TO 120%
STR. LGT	PPB	≤ 100 PPB/ ZERO AIR
DARK PMT	mV	-50 TO 200 mV
DARK LAMP	mV	-50 TO 200 mV
SLOPE		1.0 ± 0.3
OFFSET	mV	< 250 mV
HVPS	V	≈ 400 - 900
RCELL TEMP	°C	50°C ± 1
BOX TEMP	°C	AMBIENT + ~ 5
PMT TEMP	°C	7°C ± 2° CONSTANT
IZS TEMP*	°C	50°C ± 1
ETEST	mV	2000 mV ± 500
OTEST	mV	2000 mV ± 1000
Values are in the Signal I/O		
REF_4096_MV	mV	4096mv±2mv and Must be Stable
REF_GND	mV	0± 0.5 and Must be Stable
*If option is installed		

APPENDIX D - ELECTRONIC SCHEMATICS

Table D-1: List of Included Electronic Schematics

DOCUMENT #	DOCUMENT TITLE
04002	PCA, 04003, Pressure Flow Sensor Board
03956	PCA, 03955, Relay Driver
04070	PCA, 04069, Motherboard
04181	PCA, 04180, PMT Preamp
04259	PCA, 04258, Keyboard Display Interface
04420	PCA, 04120, UV Detector Preamp
04693	PCA, 04692, UV Lamp Driver
04468	PCA, 04467, Analog Output Series Res

User Notes: